

A Study on the Performance of Underground XLPE Cables Insulation Using $\tan \delta$ and Capacitance Measurements

¹A. Ponniran, ²N. A. M. Jamail

Abstract - There are several appropriate techniques can be used in order to show the characteristics of aged and unaged underground XLPE cables after sometime in service. From the characteristics, performance of the cables can be evaluated. One of the techniques is based on tan delta and capacitance measurements of the cable insulation. This study focuses on underground XLPE cables which rated at 11 kV for both 1-core and 3-core types. Tan delta and capacitance data of underground XLPE cables are obtained using a Schering bridge instrument. The measurements are performed at the temperature about 29°C and 50 Hz power frequency. The analysis of data shows that tan delta values are increased in proportion to the aging factors and voltage stressed. Meanwhile the capacitance values of the cable insulator are increased and decreased in proportion to the aging factors and voltage stressed. Therefore, tan delta and capacitance are the useful parameters for evaluating the quality of underground XLPE cables insulator.

Index Terms-- Tan δ , Capacitance, underground XLPE cables, Schering Bridge.

I. INTRODUCTION

The Underground XLPE cables are widely used for underground cables system especially in urban or compact area that provides many facilities to its community. Although underground XLPE cables possess excellent dielectric strength, low dielectric permittivity, low loss factor, good dimensional stability, solvent resistance and good thermo-mechanical behaviour [1], unfortunately, there are several weaknesses faced by XLPE cables, which bring down their performance during service. Moisture and water absorptions from environment into cable insulation are some important factors that deteriorate cable performance in service and for worse cases, it would cause the cable system to breakdown [2,7]. From these absorption activities, water treeing phenomena is introduced inside the cable insulation and causing the value of tan delta of power cable insulator to increase [3,6].

Tan delta and capacitance parameters of cable insulator can be used to describe the losses in the dielectric between insulator and core (conductor of cable) of the cables [4]. Ionic mobility in solid insulation such as PE and XLPE is greatly reduced and consequently, the tan delta values of insulation are very small [4]. Therefore, tan delta and

capacitance are the parameters that capable to determine the quality of underground XLPE cable insulator.

II. PRINCIPLE OF TAN DELTA AND CAPACITANCE PARAMETERS FOR POWER CABLES

A. Tan Delta Concept

When a sinusoidal voltage is applied across an insulator, the current through the insulator leads the voltage by less than 90° because of losses in the insulator. If the voltage and current are both sinusoidal, phasor diagram can be depicted as shown in Fig. 1. The loss angle δ is $90^\circ - \theta$, where θ is the phase angle by which the current (I) leads the voltage (V). The loss tangent is $\tan \delta$ and usually values of δ is very small, with the result that;

$$\delta \text{ (in radians)} \approx \tan \delta \approx \sin \delta = \cos \theta$$

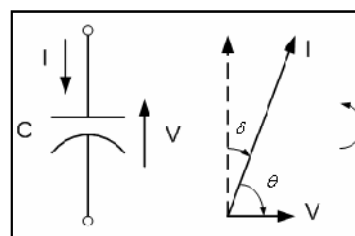

Fig. 1: Capacitor and phasor diagram, I (current) lead V (voltage) at θ° and δ is loss angle

B. Measurement Principle of Tan δ

Measurement of Tan δ is made using Schering Bridge principle as shown in Fig. 2.

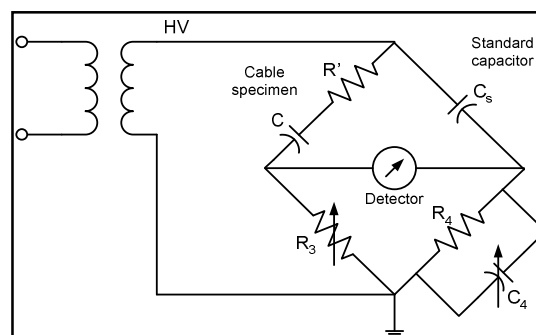

Fig. 2: Schering Bridge

Here C_s represents a standard capacitor having negligibly small losses, the series equivalent circuit of R^1

and C represents the specimen, and R_3 , R_4 and C_4 are balancing elements of the bridge. Since the cable specimen is representing as series equivalent circuit, the series equivalent circuit model with the phasor diagram is depicted as in Fig. 3.

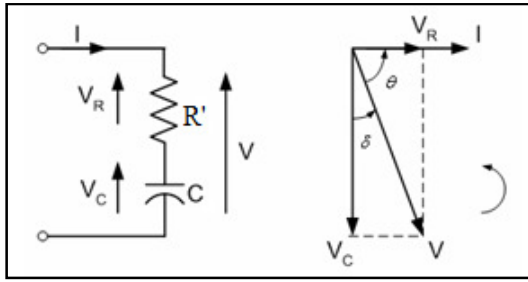

Fig. 3: Series RC model equivalent circuit and phasor diagram

The dissipation factor for the series equivalent circuit of the cable insulation is given by

$$\tan \delta = \omega R' C = \omega R_4 C_4 \quad (1)$$

III. MEASUREMENT METHOD

The measurements are carried out to determine the tan delta and capacitance values for both, aged and unaged XLPE cable insulators. The entire measurements are performed at 50 Hz power frequency using Tettex Instruments – Schering Bridge Model 2816 with automatic guard potential regulator.

Some of the cable samples are kept for a week in the test room with temperature about 29°C before the measurements are carried out and some other sample of cables are located at the open place. This is to expose some sample of cables in moisture condition and some other samples in dry condition. To avoid termination and flashover problems, the maximum measuring voltage in this case is limited to 10 kV for the whole samples of cable. Before the measurements are performed, the room temperature is recorded at 29°C. The tan delta and capacitance as a function of U test voltage data are categorized by the operating voltage of the cables and their number of core.

The measurements are performed by injecting U test voltage to the underground XLPE cable samples starting with 2 kV and then doubled to 4 kV till it reached 10 kV. Therefore, five readings are obtained in one set of a measurement. To assure the accuracy of tan delta and capacitance readings, every sample of cables are injected 20 times with U test voltage between core conductor and screen conductor (Fig(s). 4 and 5) and the final reading from every measurement is taken from the average of 20 times readings. Table 1 shows the related values of the several samples of cables.

Eleven samples of cable with various lengths are obtained from TNBD Johor Bahru, Johor, Malaysia and TNBD Kulai, Johor, Malaysia. Among the samples of cable, two cables are single core and nine cables are three cores. Only one sample of cable is unaged cable (cable 12). About the operating voltage of the cable samples, all eleven cable samples are having 11 kV operating voltage, Table 1. The corresponding measurements setup is shown in Fig(s). 4 and 5.

TABLE 1.
RELATED DATA OF UNDERGROUND XLPE CABLE SAMPLES

Cable Sample	Operating Voltage (kV)	No. of Core	Size (mm) ²	Length (m)	Service (years)
Cable 1	11	1	150	1.3	6 – 8
Cable 3	11	3	150	2.0	6 – 8
Cable 4	11	3	240	2.5	6 – 8
Cable 5	11	1	500	2.4	3 – 5
Cable 6	11	3	240	1.6	3 – 5
Cable 7	11	3	150	4.2	3 – 5
Cable 8	11	3	240	2.2	3 – 5
Cable 9	11	3	240	1.5	3 – 5
Cable 10	11	3	150	1.4	3 – 5
Cable 11	11	3	240	1.4	3 – 5
Cable 12	11	3	150	2.4	unaged

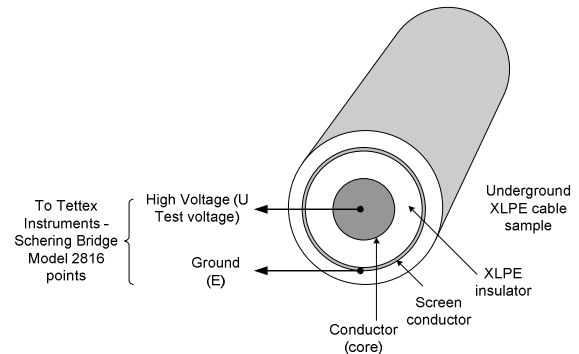

Fig. 4. Measurement setup for single-core of XLPE underground cables

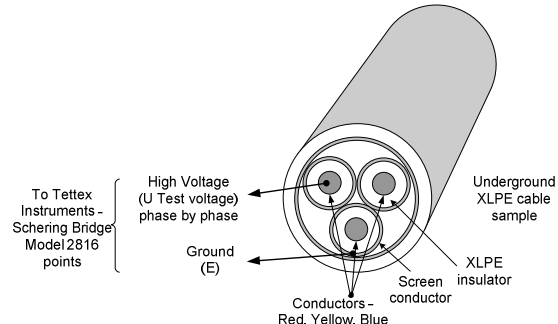

Fig. 5. Measurement setup for three-core of XLPE underground cables

IV. RESULT AND DISCUSSION

A. Constraints and Consideration

According to IEC Standard Publication 502, 1978, the maximum value of $\tan \delta$ at ambient temperature is 40×10^{-4} or 0.004 at U_0 , where U_0 is the rated power-frequency voltage between conductor and earth or metallic screen for which the cable is designed [5].

In this measurement, maximum value of U test voltage is only considered at 10 kV although the operating voltage for XLPE cable samples is 11 kV.

For analysis purpose, only 3.5 kV is being taken into account for the U test voltage. This step is incorporated as to avoid corona effects phenomena at the end of the cable samples during measurement process. $\tan \delta$ value of standard capacitance at Schering Bridge is assumed as zero.

B. Tan Delta Parameter

Single-core Cables

From the observation, tan delta values of a cable insulator are increased with its aging time during its service. Fig. 6 shows a comparison of tan delta versus U test voltage for three single-core cables after sometime in service. Unaged cable indicates very low tan delta value as compared to other cables. Cables 1 and 5 give high values of tan delta and this condition occurs due to moisture absorption; the cables sample are located on the open place before measurement process performed. The data show that the increasing of tan delta value is not only depending on water or moisture absorptions from surrounding environment into cable insulations. Besides, there are other factors like temperature of the cable, electrical stress and mechanical stress that contribute for this situation, [8].

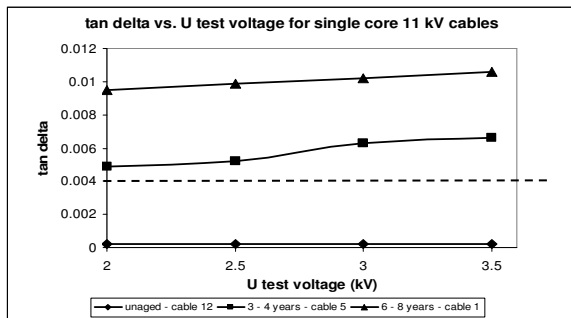

Fig. 6. Comparison of tan delta versus U test voltage after sometime in service and unaged of cables

Three-core Cables

For three cores sample of cables, after being in service for sometimes, each core (red, yellow and blue) given different value of tan delta. According to Fig. 7, the red and blue cores correspondingly, shows high tan delta value as compared to the yellow core. Although this cable is located at the open place before the measurement performed, the increment of tan delta values is not consistently similar for every single core. The measurement results then, show that it is impossible for the value of tan delta to increase simultaneously and same value for every single core after being in service for sometimes. Thus, from this condition, it can be concluded that the strength of cable insulator for every single core that deteriorated is different.

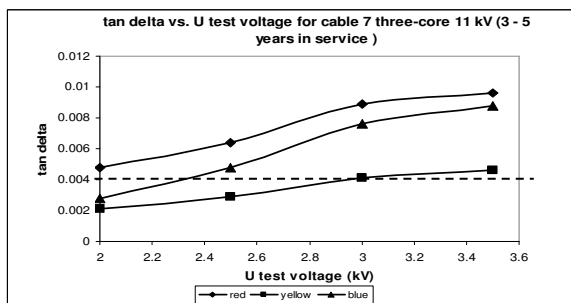

Fig. 7. Inconsistent the increasing of tan delta value for every single (red, yellow and blue) three-core cable after 3 - 5 years in service

When the tan delta value of a cable insulator is high, the potential for this cable to breakdown during service is also high. This situation occurs when the insulator of the cables loss their strengths then causing the ionic mobility to

increase and influence the conductivity level within cable insulator. As a result, the value of tan delta would rise and promote the breakdown to occur and in worse condition, the cable will be breakdown. Fig. 8 represents a condition with very high values of tan delta as compared to 0.004 [5] and it possibly due to excessive content of moistures inside the insulator of the cable.

Fig. 9 illustrates very low values of tan delta, for every single core, as compared to 0.004. Although the cable is taken after 3 – 5 years in service, the value of tan delta is still very small.

Fig. 10 depicted the comparison of the tan delta values between two three-core cables with the same duration in service, 3 – 5 years.

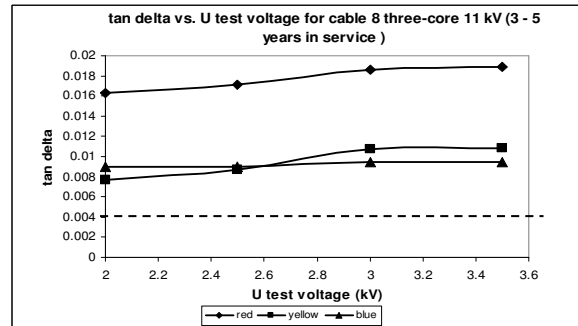

Fig. 8. The high value of tan delta for three-core cable after 3 – 5 years in service

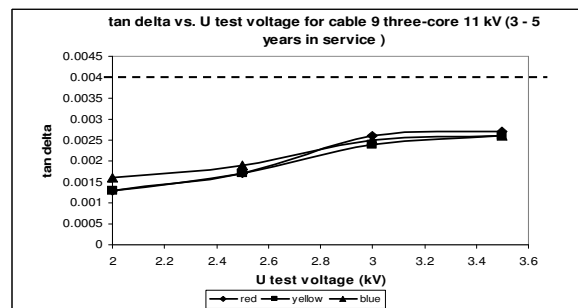

Fig. 9. The low value of tan delta for three-core cable after 3 – 5 years in service

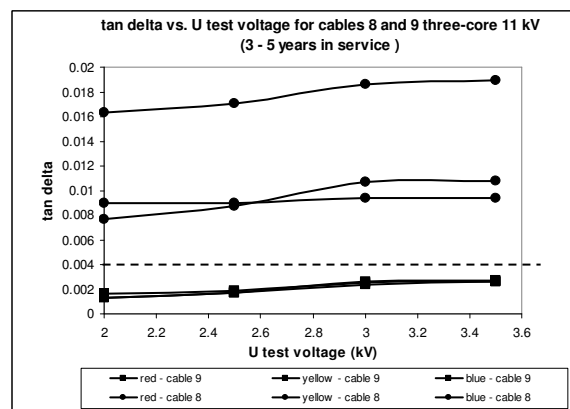
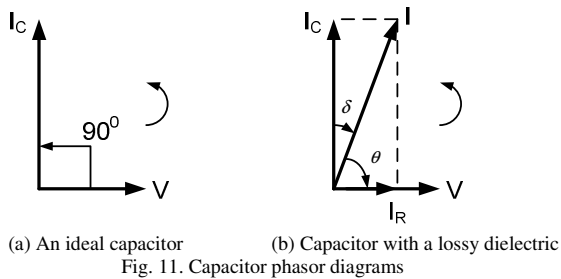

Fig. 10. The comparison of low and high values of tan delta for two three-core cables after 3 – 5 years in service

C. Capacitance Parameter

The phasor diagram of an ideal capacitor and a capacitor with a lossy dielectric are shown in Fig. 11. Fig. 11(a) shows there is no losses appear if a pure capacitor

characteristic is obtained. Because of lossy dielectric characteristic (Fig. 11(b)), the power losses will be introduced and heat from conductor is one of the aging mechanisms [4,6]. An introduced of heat (thermal) in conductor, aging of insulator will be accelerated and causes strength of capacitance deteriorated. Nevertheless, in real situation, the lossy component in capacitor (insulation) is appeared and need to be considered because the component causes capacitor lack of their strength, Fig. 11(b).



Three-core Cables

Data from measurement show that the capacitance value increased when U test voltage is step up meanwhile some other samples of cable show that capacitance value decreased when U test voltage is step up. The situation shows that the dielectric of the cable is contaminated. Fig. 12 shows the capacitance values in some of XLPE cable samples versus U test voltage. From Fig. 12, cables 8 and 9 are taken after three to five years in service; meanwhile cable 12 is unaged cable. The value of capacitance for cables 8, 9 and 12 versus U test voltage showing that the characteristic of capacitance values of aged and unaged cables is uneven condition.

An ideal case; the value of cable capacitance should be constant, Fig. 12(c). However, in these measurements the values of capacitance are not constant when U test voltages are varying from low to high.

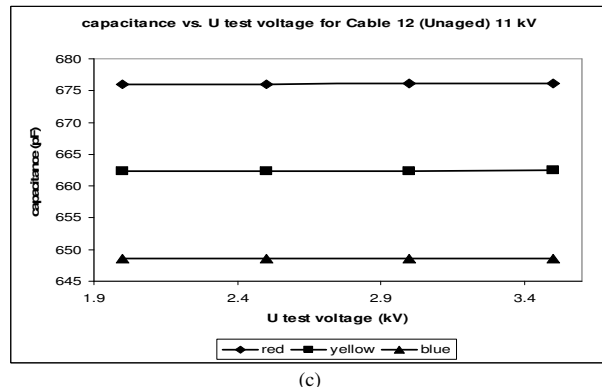
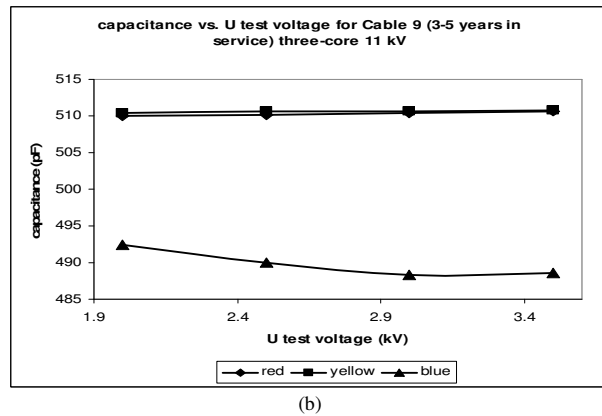
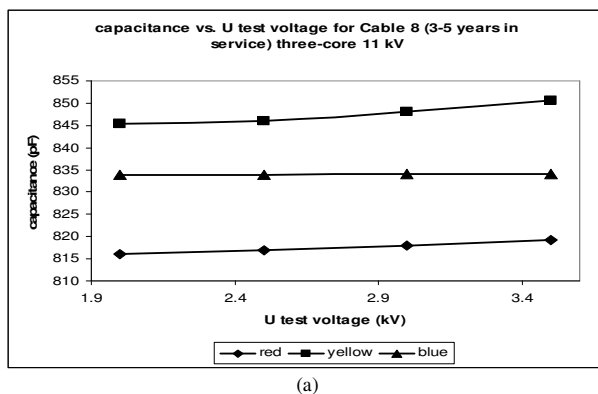

Fig. 12. Capacitance values for cables 8 (a), 9(b) and 12(c) (unaged)

V. CONCLUSION

After power cables operate for sometimes in service, the value of tan delta is increased. The value of tan delta also increased when the U test voltage is increased. It is because, in most insulating systems, the value of tan delta is intensifying with the increment in applied voltage or stress voltage. However, for unaged cable (cable 12), the increment of tan delta value against U test voltage is extremely small (0.0002) at 3.5 kV of U test voltage.

Besides, the capacitance values are not constant when U test voltage is applied. This situation can be justified that the cables insulation in aging or defect conditions and caused the insulation properties changed. Therefore, it leads the value of cables capacitance versus U test voltage are not constant at the same level.

Therefore, tan delta and capacitance measurements are able to evaluate and investigate the quality of underground XLPE cables insulation system.

VI. ACKNOWLEDGMENT

The author/authors would like to thank the Ministry of Higher Education, Malaysia for supporting this research under the Fundamental Research Grant Scheme (FRGS), Tenaga Nasional Berhad Distribution (TNBD), Johor Bahru, Malaysia, Institute of High Voltage and High Current (IVAT), Faculty of Electrical Engineering Universiti Teknologi Malaysia and Universiti Tun Hussein Onn Malaysia for any technical supports and assistances in the laboratory works.

VII. REFERENCES

- [1] R. Sarathi, Supriyo Das, C. Venkateshaiah and N. Yoshimura (2003). "Investigation of growth of electrical trees in XLPE cable insulation under different voltage profile." *Annual Report Conference on electrical Insulation and Dielectric Phenomena*. IEEE. 666-669.
- [2] S. V. Nikolajevic. "Investigation of water effects on degradation of crosslinked polyethylene (XLPE) insulation." *IEEE Transactions on Power Delivery*. Volume 8, Issue 4. IEEE. 1993. (1682 – 1688).
- [3] Nikolajevic, S.V.; Kostoski, D.D. "Accelerated aging of cross-linked polyethylene (XLPE and TR XLPE) cable insulations in wet conditions." *Electrical Insulation and Dielectric Phenomena Annual Report*. Conference on 25-28 Oct. 1998. (694 - 697 vol. 2).
- [4] R. Bartnikas and K.D. Srivastava. *Power and Communication Cables: Theory and Applications*. New York: Institute of Electrical and Electronics Engineers, Inc. B., 2000.
- [5] IEC Standard, Publication 502 – 2nd ed. *Extruded Solid Dielectric Power cables for Rated Voltage from 1 kV to 30 kV*, 2nd ed., 1978.
- [6] Nikolajevic, S.V. "The influence of the water on water absorption and density of XLPE cable insulation." *Power Delivery, IEEE Transactions* on Volume 13, Issue 2, April 1998. (297 – 303).
- [7] Nikolajevic, S.V. "Investigation of water effects on degradation of crosslinked polyethylene (XLPE) insulation." *Power Delivery, IEEE Transactions* on Volume 8, Issue 4, Oct. 1993. (1682 – 1688).
- [8] John Densley. "Aging and Diagnostics in Extruded Insulations for Power Cables." *IEEE 5th International Conference on Conduction and Breakdown in Solid Dielectrics*. 1995. (1-15).

Asmarashid Ponniran, was born in 1979 in Johor, Malaysia. He received his B.Eng (Electrical Engineering) and M.Eng (Electrical – Power) respectively from Universiti Tun Hussein Onn Malaysia (UTHM) in 2002 and Universiti Teknologi Malaysia (UTM) in 2005. He is currently working as a lecturer in the Department of Electrical Power Engineering at Universiti Tun Hussein Onn Malaysia (UTHM). He is currently members of Board of Engineers Malaysia (BEM) and International Association of Engineers (IAENG). His field of interest includes Power Cables System, Power Quality and Power Electronics.