

Embedded Web Server for Infra Red Remote Control

¹Nor Azarina Nordin, ²Siti Zarina Mohd. Muji, ³Mohd Helmy Abd Wahab, ⁴Muhammad Syukri Ahmad

^{1,2,3}Department of Computer Engineering,
Faculty of Electrical and Electronic Engineering,
University College of Technology Tun Hussein Onn (KUiTTHO)
P.O.Box 101, 86400 Parit Raja, Batu Pahat, Johor
E-mail: ¹eliana15995@yahoo.com, ²szarina@kuittho.edu.my, ³helmy@kuittho.edu.my

⁴Department of Electrical Engineering,
Faculty of Electrical and Electronic Engineering,
University College of Technology Tun Hussein Onn (KUiTTHO)
P.O.Box 101, 86400 Parit Raja, Batu Pahat, Johor
E-mail: ⁴mshukri@kuittho.edu.my

ABSTRACT

This paper is focused in embedded web server to control the infra red application through the internet. The main purpose of the infra red application is to count up the amount of something small that is go through the transmitter and receiver. This application could be used in the dangerous field of research such as to count up the sum of ant that is living in one area. This project makes use of PICDEM.net board as a server and develops a CGI (Common Gateway Interface) program as interface between web server and hardware part. User can control the hardware part via the web page which is built using HTML (HyperText Markup Language) language that is stored in the external EEPROM (Electrically Erasable Programmable Read-Only Memory). The source code to programming the hardware operation is stored in the program memory of the microcontroller. This research shows that PICDEM.net board can be used to control infra red application successfully and from this research we can develop more powerful and suitable application that can give advantages to the internet world.

Keywords

Embedded web server, PICDEM.net board, CGI, HTML

1.0 INTRODUCTION

With the emergence of internet application, the technology is keep changing in every second. Currently, embedded web servers become a trend for controlling any application by utilizing web as a transmission medium. As the technology is growing rapidly, this application intends to lead the latest technology in the world. With this application, we can assure that any application related to controlling hardware through web can be developed easily. The issues that are always

encountered after the existence of this embedded web server are the limitation of memory capacity to support all the script and protocol. The limitation can be reducing by simplifying the TCP/IP protocol to take only the important layers in the protocol (Tao Lin et.al, 2004). The study related to this area is continuously and this is the initial part of the research to explore the embedded web server for controller. Due to the world of globalization, the physical computing environments take place where most of the appliance will able to communicate and controlled through computers.

2.0 RELATED WORK

According to Ramkrishnan (2004), the embedded web server can be built on the 16 bit microcontroller. A HTTP server is implemented to enable web based data acquisition and control. But the application software and a full blown TCP/IP stack incorporating the protocols SMTP, FTP, DHCP and UDP are still under development.

While Tao Lin et. al (2004) stated that, the air conditioner can be controlled using embedded web server through a browser. 8 bit microcontroller has been used to reduce cost and size and make it easy to be embedded into equipment especially in consumer appliances. And the second reason is power assumption due to some devices are often required to operate for an extremely long time on batteries.

According to Muhammad Syukri Ahmad (2004), the system is developed to ease the user to control and monitor the electrical apparatus using the internet. This project uses a PICDEM.net Development board as a server where the extra circuit such as electrical apparatus which is controlled by web page will be connected.

3.0 CGI AND HTML

CGI also known as Common Gateway Interface is a scripting language as an interface between web server

and hardware part. CGI can be written in C, C++ and Perl. HTML is used to design the web interface while CGI sends a request from client (web) to the web server.

4.0 STEPS TO DEVELOP THE SYSTEM

Figure 1 shows the three main important process of this research. As we can see, the first block is web browser which is the place to enter the address of web page. Once it detects the address, the information will then send to the server to complete the request from the client. After a few minute the web page will occur that have information about the infra red application. User can choose whether to ON or OFF the infra red circuit that is connected to the PICDEM.net board.

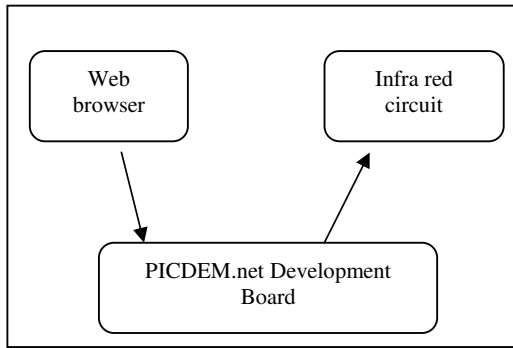

Figure 1: The main process of this project

Before the above process can be done, here is the step to develop the overall system.

4.1 Design the web page (web site is written in HTML)

Web page is worked as interface to ease the user to control the infra red circuit using the Ethernet/internet. The web page is build using HTML code. All texts in HTML document is intended for display on browser screen.

4.2 Design the infra red circuit

The apparatus part consists of the architecture of the control circuit of the infra red circuit, which is connected to the PICDEM.net board. The circuit is built according to the active low concept where the circuit is active when the input is 0 and deactivated when it is 1. This extra circuit will be connected to the microcontroller chip, where the function is to amplify the current, which come out from the microcontroller pin.

4.3 Reprogramming and Restoring the Application Firmware

The main program was embedded to the PIC16F877 microcontroller using ICD (In-circuit Debugger) in MPLAB 5.5 and PICC Lite. The PICDEM.net Ethernet/Internet Development Board does not include the tools for clearing and reprogramming the microcontroller. For this project it will use appropriate device programmer which is MPLAB ICD Development System that provides a complete set of tools for device emulation and programming. MPLAB software is set according to the following configuration option:

Oscillator: HS
 Wacthdog Timer: Disabled
 Low Voltage Programming: Disabled

4.4 Loading (or Reloading) the Web Site into EEPROM

The web that has been built using HTML language must be downloaded into the external EEPROM (Varatharasan a/l Sreenivasan.,2005). To download a new or modified web site it can be done without affecting operating firmware. The web site image can loaded in one of the two ways:

- a) Serial Configuration mode (RS-232) from a local host system
- b) File Transfer Protocol (FTP) over the network

This project use the first way that's using RS232. As the file is downloaded, LED D5 will blink to indicate that the data is received.

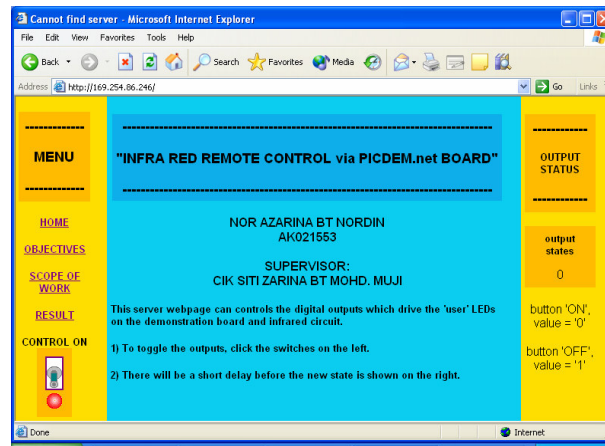

Figure 2: The web page

4.5 Testing the project

If the testing passes, then the project already finished. If the testing failed, troubleshooting need to be done to overcome the problem until the system works successfully. The user had to open the Internet Explorer and insert the IP address of PICDEM.net board in the URL to be connected to the server. As an example, when the IP address of the board 169.254.86.246 is typed at the URL, the web page which is stored in the PICDEM.net memory will pop out at the monitor.

5.0 INFRA RED APPLICATION

For this paper, we are trying to apply the application of embedded web server to the infra red remote control. Based on the experiment that has been done, if the user click the button in the web page to ON the LED infra red at the transmitter, the receiver will accept that signal successfully. This can be measured by locate the transmitter and receiver in the same coordinate and when something is situated between both part, the LED indicator at the receiver will ON.

The infrared circuit consists of two devices; a light emitter and a light receiver which is connect to comparator LM399. Sensing is achieved when these rays are interrupted by the object. Figure 3 shows the infra red circuit that is used in the project. The comparator circuit is used to detect the presence of a something covering the IR receiver. The variable resistor, 250k connected in series with the IR receiver. Decreasing the variable resistance will increase the threshold sensitivity of the phototransistor.

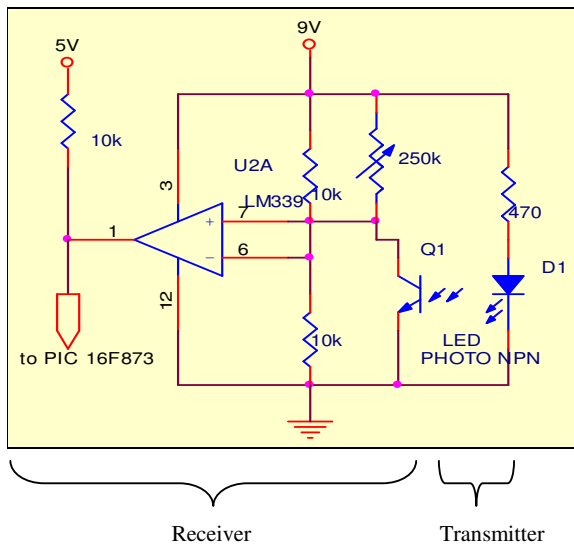

Figure 3: The infra red circuit.

6.0 PROJECT OPERATION

To ON and OFF the infrared circuit, the users must access the web page; the PICDEM.net Development Board IP (Internet Protocol) address has to be keyed at the URL. After keying the IP address, the web page that had created will pop up on the web browser. User must click on the control button on the web page that appeared. Then the browser will collect the data and send it through the HTTP on the internet/Ethernet to the web server.

Web server is located in PIC16F877 at PICDEM.net Development Board. Here, the web server will transfer the received data to the infrared circuit. CGI are used as interface program which is created to monitor the received control instruction. Figure 4 shows the flow chart of the project operation for control the infrared circuit using button at the web page.

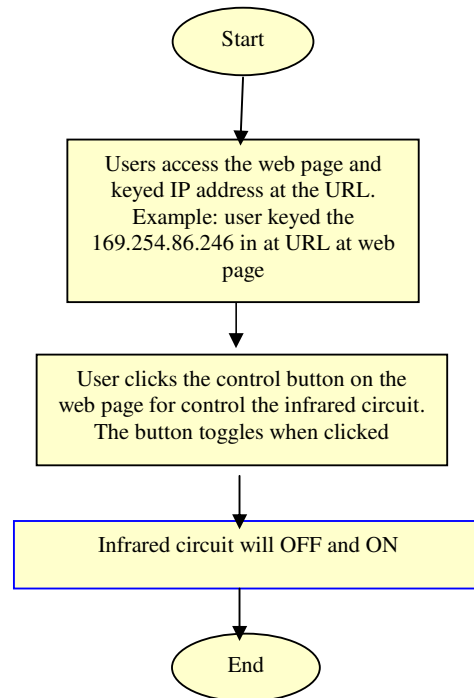

Figure 4: Flow chart of overall system

7.0 ANALYSIS

Analysis is an important part in this project. It is done to show the operation of the system

7.1 Operation of PICDEM.net board

PICDEM.net Development Board is a demonstration implementation for a TCP/IP based embedded web

server. It is a typical low specification microcontroller that could be equipped to operate as a miniature web server. A microcontroller with an embedded TCP/IP stack is called an Embedded Web Server. To program the PIC microcontroller, ICD tools will be used. This is because the PICDEM.net Development Board has an ICD connector. This allows the PIC to be programmed on the board directly without taking out the microcontroller.

7.2 Designing the web page

Web page is like an interface for the user to control the infrared circuit using the Ethernet/ internet. This web page have three different frames; middle, left bottom and right bottom. The middle frame will changes according to the user's selections. The left frame is for menu and control button for infrared circuit. The right frame is to show the input/output status. Figure 5 shows the entire frame in the web page.

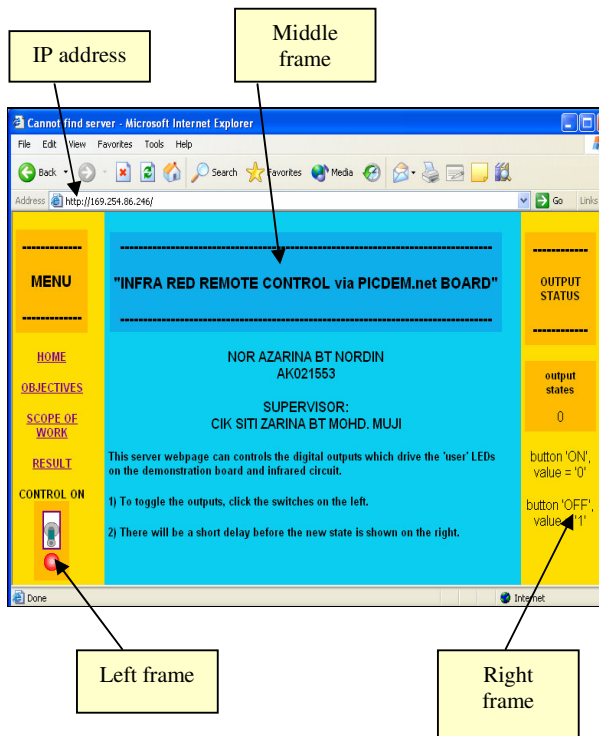

Figure 5: The important Iframe in the web page

User can control the infrared circuit, which is connected to the PICDEM.net board with just pressing the control button on the web page and at the same time there will be changes on the infrared circuit either it's ON or OFF.

8.0 RESULT

By the end of this project, the infrared circuit can be controlled and monitored via internet using PICDEM.net board and the range distance of acceptance for the signal from the receiver to the transmitter is 0.5 until 1 meter.

8.1 Infrared system

When the user clicks the button on the web page, the infrared circuit will ON. If we click once again, the circuit will OFF. The voltage for infrared circuit is supplied by microcontroller pin at RB2 and ground on PICDEM.net Board.

8.2 Web page system

The web site provides a simple demonstration of several important concepts for an embedded control system and user-friendly information. The initial homepage is actually an HTML frameset; this is a common technique where two or more pages are displayed simultaneously to give the appearance of a single page. The home page have three parts; middle, left bottom and right bottom. Each is implemented using simple HTML and demonstrates a different concept.

9.0 CONCLUSION

In conclusion, the success of this research will gain the other research that will apply this concept in the other application which is more gorgeous. Embedded web server will open the new era of controlling appliance via internet.

10.0 FUTURE RESEARCH

Implement a system that two or more user can access a web page at the same time.

REFERENCES

- Muhammad Shukri bin Ahmad. (2005). Embedded Web Server. Kolej Universiti Teknologi Tun Hussein Onn, Batu Pahat. M.Sc Thesis.
- Varatharasan a/l Sreenivasan. (2005). Lean Web Server for Embedded Control. University College of Technology Tun Hussein Onn, Batu Pahat. M.Sc Thesis.
- Tao Lin, Hai Zhao, Jiyong Wang, Guangjie Han, Jindong Wang. (2004). "An Embedded Web Server for Equipments." Parallel Architectures, Algorithms and Networks. Proceeding 7th International Symposium on 10-12 May, 2004. Pages: 345-350.

Ramakrishnan, A. (2004). 16-bit Embedded Web Server. Sensor for Industry Conference. Proceedings the ISA/IEE. Pages: 187-193.