



Examensarbete *Master Thesis*  
Agronom - mark/växt

# RTLS - Real time location systems

An inventory study for agriculture  
applications and requirements

*RTLS - Real tid lokaliserings system*  
*En inventering av användningsområden inom*  
*lantbruket*

Mattias Larsson

SLU, Sveriges lantbruksuniversitet  
Institutionen för energi och teknik

*Swedish University of Agricultural Sciences  
Department of Energy and Technology*

RTLS- Real Tid Lokaliserings System- En inventering av lantbruksapplikationer och dess krav

*RTLS- Real Time Location Systems- An inventory study for agriculture applications and requirements*

Författare/*Author*: Mattias Larsson

Handledare/*Supervisor*: Anders Larsson, SLU, Dept. of Energy and Technology  
Anna Rydberg, JTI, Institute of Agricultural and Environmental Technology

Examinator/*Examiner*: Per-Anders Hansson, SLU, Dept. of Energy and Technology

Kurskod/*Course code*: EX0579

*Independent project/degree project in **agricultural science**, Advanced Level, 30 HEC*

Examensarbete (Institutionen för energi och teknik)  
*Master's Thesis (Department of Energy and Technology)*

ISSN 1654-9392

2010:02

Uppsala 2010

Nyckelord/*Key words*: RTLS, RFID, VIR, Herd management, traceability, precision agriculture, Irrigation management

## ABSTRACT

The trend towards increasingly large farming units raises questions regarding how to better monitor production. Larger units make the impact from possible errors more severe, which increases the pressure on management supervision. To cope with management issues, prevent errors and handle increased demands on traceability and documentation, the Real Time Location Systems (RTLS) concept is making its way into various parts of agriculture.

In sectors outside agriculture, RTLS are already being used successfully to track and locate items through nodes at different levels of accuracy, such as room level or the relative or absolute position. Empirical data can be received in real time from the nodes. Such systems are well established among dairy herds for feed management and automation. Their application in crop production is less well developed, though there are potential areas of application, such as digital recordkeeping of applied inputs, e.g. fertilizers and pesticides, and environmental monitoring to forecast disease outbreaks or give precise and automatic irrigation. RTLS can also be used to trace agricultural goods through the distribution chain to the end customer.

This inventory study examines the state-of-the-art of available RTLS solutions for farming, in practice and in agricultural research. The study is based on material found in the literature and on interviews conducted with researchers and representatives of agribusinesses.

Probable solutions for future applications include RTLS tracking of dairy cows with exact location capability using electronic passive ear tags. In crop production, RTLS for yield mapping and spatial environmental monitoring are seen as potential applications. Although possible solutions exist, it is clear that the knowledge of this technology is low in the business and further research is needed in order to raise sector awareness about RTLS applications in agriculture.



## SWEDISH SUMMARY

### SAMMANFATTNING

Trenden med en strukturrationalisering mot större enheter med mindre personal per producerad enhet höjer behovet av en effektiv produktionsövervakning. Stora enheter med hantering av stora varuflöden leder till att ett misstag får större konsekvenser och det gör att kraven som ställs på lantbrukaren ökar. För att klara detta och möta större krav på spårbarhet och dokumentation skulle RTLS (Real Tid Lokaliserings System) kunna hjälpa till att automatisera eller åtminstone effektivisera dokumentation spårbarhet och även precision inom lantbruksproduktionen.

Inom andra branscher än lantbruk har redan RTLS gjort sitt intåg, det används inom logistik och transport, sjukhus och på byggarbetsplatser för att ge möjlighet att spåra verktyg, varor och personal för att snabbt kunna se var de befinner sig och enkelt göra t ex en löpande lagerinventering. Det finns olika noggrannhet i systemet. Man pratar om exakt positionering där man ger föremålets placering en koordinat, det vanligaste är dock att man placerar läsare vid strategiska platser för att avläsa när objektet passerar genom t ex en dörr.

Ett RTLS kan vara uppbyggt på olika vis, genomgående är dock att systemet har en eller flera läsare och taggar som är fästa på de enheter man vill registrera. Taggarna kan vara utformade på olika vis, den här studien behandlar främst system med passiva RFID (Radio Frekvens Identifikation) taggar men även aktiva taggar förekommer. I ett passivt system saknar taggarna batteri och är uppladdade av ett elektromagnetiskt fält som sänds ut av läsaren. Aktiva taggar har längre räckvidd än passiva men batterierna måste bytas och taggarna är betydligt dyrare.

Det finns ett antal potentiella applikationer för RTLS inom lantbruket, inom animalieproduktion är framförallt ett system för exakt positionsbestämning av djur med hjälp av passiva taggar i form av elektroniska öronmärken. Ett sådant system skulle kunna användas för att spåra upp djur i stora besättningar men även ersätta befintliga system för brunstpassning och transponderutfodring. Inom växtodling skulle ett potentiellt system kunna samla in klimatdata i ett fält och bearbeta denna för att skapa exakta bevattningskartor eller sjukdomsprognoser. Ett annat system skulle kunna användas för att skördekartera och spåra skördade produkter.

Slutsatsen är dock att det finns stora möjligheter med RTLS inom varierande applikationer, dock är kunskapen om möjligheterna mycket liten och mer undersökningar behövs för att underbygga de olika systemens praktiska tillämpbarhet



## PREFACE

This work was commissioned by the Swedish Institute for Agriculture and Environmental Technology as part of their future development projects.

The conclusions drawn by this work will set the basis for a second Master's project examining the technical design of equipment that could be used in future agriculture. Ultimately, this project might result in new products being developed for agriculture applications.

During the time-span of this work, from late summer to Christmas, the development of RTLS in the agricultural sector progressed further. During the period, several new articles on the subject were published and a newly launched system for cow management rather similar to that proposed in the present work was exhibited at Agromek, an agrotechnical exhibition in Denmark. This can be pessimistically interpreted as the present project being completed too late, or optimistically interpreted as showing that this report is at the front line of agricultural research and that the ideas presented are of high current relevance. There is clearly rapid progress underway in the area of RTLS for agriculture, so a review of the state-of-the-art is urgently needed.





# TABLE OF CONTENTS

1. INTRODUCTION .....	13
1.1 Introduction .....	13
1.2 What is RTLS? .....	13
1.3 Objectives .....	13
1.4 Limitations/Scope .....	14
2. MATERIALS AND METHODS .....	14
2.1 Research design .....	14
2.2 Literature review .....	14
2.3 Interviews .....	14
3. LITERATURE REVIEW .....	15
3.1 Technical description of RTLS .....	15
3.2 Agricultural production - areas of application .....	17
3.2.1 Applications for livestock production .....	17
3.2.2 Applications for crop production .....	19
4. RESULTS .....	22
4.1 Possibilities – the findings from the literature review .....	22
4.2 Target groups .....	23
4.3 Economic analysis .....	24
4.3.1 Livestock production .....	24
4.3.2 Crop production .....	25
4.4 Potential applications for Swedish livestock production chain .....	26
4.4.1 Management .....	26
4.4.2 Behaviour research .....	27
4.4.3 Application at abattoirs .....	28
4.5 Potential applications for Swedish crop production .....	28
4.5.1 Environmental monitoring .....	28
4.5.2 Traceability .....	29
4.5.3 Security .....	29
4.6 Conceptual solutions .....	30
4.6.1 RTLS in livestock production chain .....	30
4.6.2 RTLS application in crop production chain .....	32
4.7 Technical description of equipment .....	34
4.7.1 Technical description - RTLS for animal monitoring .....	34
4.7.2 Technical description - soil sensors .....	36
4.7.3 Technical description - RTLS for yield mapping .....	37
5. DISCUSSION .....	38
5.1 Applications in livestock production .....	38

5.2 Applications in crop production.....	39
6. CONCLUSIONS .....	40
7. REFERENCES .....	42
7.1 Literature .....	42
7.2 Internet sources.....	44
6.3 Personal communications .....	44
APPENDIX A .....	45
APPENDIX B.....	53

## List of figures

Figure 1. Ear tag identification .....	16
Figure 2. Information handling, livestock production.....	31
Figure 3. Flowchart of information handling, crop production .....	33
Figure 4. Section drawing of a loose house for dairy cows .....	35
Figure 5. RTLS animal monitoring by absolute positioning with sensor array .....	35
Figure 6. RTLS soil sensor array .....	37
Figure 7. RTLS post-harvest traceability systems .....	38

## List of tables

Table 1. Technical description of RTLS .....	17
Table 2. Crop data for Sweden: area, yield, number of production units.....	23
Table 3. Livestock data for Sweden: Number of livestock, number of production units ...	24
Table 4. Relative change in cost when applying RTLS in livestock production .....	25
Table 5. Relative change in cost when applying RTLS in crop production.....	25
Table 6. Limit values in animal houses .....	34

## Nomenclature

RTLS	Real Time Location Systems
RFID	Radio Frequency Identification
GNSS	Global Navigation Satellite System
GPS	Global Positioning Systems
GLONASS	Global Navigation Satellite System
VRI	Variable Irrigation Rate
EID	Electronic Identity Tag
IR	Infra red
RF	Radio Frequency
Sensor array	Network of sensors
Rumen bolus	Identity tag inserted in rumen
Node	One sensor in a network



# **1. INTRODUCTION**

## **1.1 INTRODUCTION**

Farming is being concentrated into increasingly large units and production units are tending to become more specialised, with an increased level of mechanisation. This means that fewer people are now responsible for a larger amount of agricultural products. There is a wide range of applications in agriculture where positioning of different units is desired. In animal production there are obvious benefits in being able to track and find individuals in large herds of e.g. cattle or pigs. In addition, public opinion is placing pressure on agriculture to increase animal welfare and decrease negative environmental impacts. Farmers today have large amounts of paperwork to complete on recording of cattle and farm operations to meet the demands for traceability from the health and environment authorities. In future, agriculture will face an increased demand for food due to a growing global population, as well as a reduced input of energy due to lower availability of fossil fuels. One way of managing the increased food production and reducing energy consumption, without increasing the negative impact on the environment, is to use technologies for precision agriculture. In large herds of animals it is difficult for the farmer or herdsman to monitor all individuals, although failure to do so can cause severe suffering for weak animals and loss of income. Satellite positioning, such as GPS or Glonass, is already an established method in agriculture, but it is limited by obstacles in the signal pathway, such as tree foliage or building roofs. In addition, this technology is advanced and expensive if one unit has to be purchased per animal. This is where RTLS (Real Time Location Systems) could be of interest.

Whether it concerns traceability, precision farming or animal welfare, a system is needed to aid the farmer in his daily work. Real Time Locating Systems could be used to solve this need for real time information and recording.

This report explains what the RTLS concept is and how it can be used in different applications. It also provides suggestions on where future work should be done to meet the need for technical solutions.

## **1.2 WHAT IS RTLS?**

Real Time Locating Systems (RTLS) enable the user to track items and/or receive data from the tracked items in real time. The RTLS uses tags and receivers which usually communicate by radiofrequency signals. Such tags are called RFID (Radio Frequency Identification) tags.

## **1.3 OBJECTIVES**

The overall aim of this project was to identify areas where RTLS can be applied within the agricultural sector, describe the different applications and the technical demands on these applications and determine the role RTLS play at present and in the future. In order to fulfil this aim, the specific objectives of the study were to:

---

1. Identify and describe the main areas of present RTLS applications in agriculture.
2. Identify and evaluate future fields of application in agriculture.

#### **1.4 LIMITATIONS/SCOPE**

The scope of this work was to find helpful solutions in livestock and crop production. Forestry was excluded.

The study did not deal with technical details, since these will be addressed in a second Master's project based on the findings of the present work.

The work was limited to finding solutions suitable for Scandinavian agriculture.

## **2. MATERIALS AND METHODS**

In order to locate the main areas where RTLS have their most extensive utilisation, it is important to have thorough background knowledge of previous developments in the area. This knowledge was acquired here through a literature review based on library services and online databases of scientific papers. Once the background had been established, the most important areas were chosen.

### **2.1 RESEARCH DESIGN**

The primary methods used to achieve the objectives stated above for this thesis were:

1. An extensive literature review
2. Interviews with scientists, authorities and industry.
3. Evaluation of methods 1 and 2.

### **2.2 LITERATURE REVIEW**

The literature review aimed to provide an understanding of the past and present and to show the stage of research for future applications. The majority of the literature reviewed was obtained from scientific databases and conference proceedings.

### **2.3 INTERVIEWS**

Interviews were held to identify areas where RTLS can be beneficial. Since this project sought solutions for livestock production and crop production, a large variety of different production forms were included. This made it difficult to achieve representative results from quantitative farmer interviews. However, since the number of farm businesses and scientists was relatively limited, it suited the time frame of this study to establish an analysis based on the results of qualitative interviews with those stakeholders.

List of interviewees:

---

- Christina Ohlsson; DeLaval; Solution manager; 11/10/2009
- Göran Nybom; Tractechnology; 06/10/2009
- Jenny-Ann Sundelöf; Ugglarps AB; Supply manager; 01/10/2009
- Joakim Ekelöf; SLU; Scientist; 13/10/2009
- Johan Arvidsson; SLU; Scientist; 23/10/2009
- Kristher Svensson; Scan, supply manager; 28/10/2009
- Kristina Lindgren; JTI; 30/09/2009
- Lars Andersson; OLW; Local manager; 01/12/2009
- Mats Karlsson; Yara, Product flow manager; 29/10/2009
- Sören Kjellström; Chief herdsman; 07/10/2009
- Per Peetz Nielsen; SLU; Scientist; 23/09/2009
- Peter Malm; HS Kristianstad; 02/10/2009

### 3. LITERATURE REVIEW

In order to understand and evaluate potential applications, it is essential to understand the basis of RTLS. This section gives a brief description of the technical functions behind RTLS and their different applications. It also gives a review of the applications used in commercial agriculture and in research, as well as potential future applications.

#### 3.1 TECHNICAL DESCRIPTION OF RTLS

Real Time Locating Systems do exactly what the name indicates: they track the location of units in real time. They also supply measured values from the unit. A system consists of four main components.

**Tags:** Small electronic units that can be attached to a wide range of subjects.

**Location sensors:** Reading antennae that can locate the tag.

**Location engine:** Software that allows communication between tags and location sensors.

**Middleware and application software:** The interface that communicates with the end-user

The units can be located at fixed points and return values from the predefined point, or can be attached to a moving subjects, in which case the system can locate these. There are different ways of locating objects, with differing accuracy of exact positioning.

**Presence-based location:** The tag location is returned in terms of whether it is present in a certain area. For example, the cow has entered the feeding area.

---

**Location at room level:** The tag location is returned in terms of whether it is in one corner of the room or another. For example whether a cow is at feeding station number 1 or 2.

**Location at choke points:** Similar to the presence-based location, although it is possible to know by which gate the cow entered the sleeping area (Fig. 1).

**Precise location:** The tag location is given an exact position in the room, comparable to GPS positioning. For example the cow is lying in the gutter two metres from the watering-trough (Fig. 1).

In brief, the RTLS works with one or several receivers and one or several RFID tags which include specified information. When the tag comes close enough to the reader, it is charged by the electromagnetic field sent out by the reader. The charge creates a radio frequency from the tag which includes the preset parameters in the tag. This is the fundamental principle of a passive system. An active system needs an externally powered tag, although this system has a higher reading distance and a higher capacity to carry information (Finkenzeller, 2003).

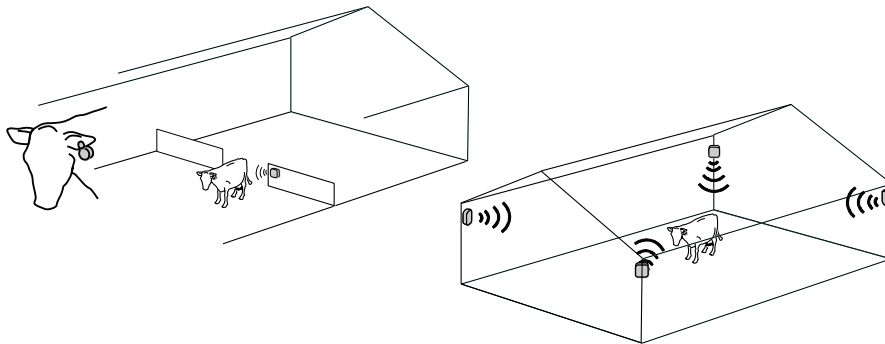

Figure 1. Ear tag identification at choke point(left) and exact location by sensor array (right).  
(Kim Gutekunst, JTI, with permissions)

There are several types of tags. The most commonly used are discs, sometimes called coins, which are geometrically similar to a coin in shape and size. There are also tags with glass housing to be inserted under the skin of an animal, or thin tags for sticker labels and luggage labels. There are even tags incorporated in heavy duty metal casing (Finkenzeller, 2003).

The reading range differs between the different types and is determined by the size of antenna as well as the source of power. A tag with internal power supply has a longer reading distance compared with the passive type, although this causes the tag to have larger size and higher price. The reading range is also radio frequency-dependent. The radio frequency signal can be divided into three types: LF (low frequency, 3-300 kHz), HF (high frequency, 3-30 MHz) and UHF (ultra high frequency, 300 MHz - 3 GHz) (Malik, 2009). Technical descriptions of different tags and their specifications can be found in Table 1.



*Table 1. Technical description of RTLS*

<b>Specifications</b>	<b>Passive</b>	<b>Semi-passive</b>	<b>Active</b>
Size	Depends on range; varies from the size of a rice grain to a car number plate	Depends on battery life and size	Depends on battery life and size
Locatability	Only when interrogated by the RF antenna field	Only when interrogated by the RF antenna field intervals	Locatable at preset intervals
Battery life	None	Up to 10 years	Up to 5 years
Range	Up to 20 m	Up to 100 m	Up to several hundred metres
<b>Cost</b>	<b>~SEK 10-30</b>	<b>~SEK 10-50</b>	<b>~SEK 50</b>

Source: Malik, 2009

The RFID technology is widely used and can be found in applications everywhere, from bus tickets to personal ID cards. It can monitor people's movements, locate and track assets and monitor usage of these assets. It can thus improve industrial throughput, structure of facilities, customer service and response time. These are just a few areas where the system can be used. Since it is a simple and cost-effective system, it has large potential. The tags can store and transmit data and, combined with a sensor array, can form a RTLS which can track the location of every RFID tag (Malik, 2009).

Agriculture worldwide is a large potential market for electronic identification, and in 2008 90 million tags were sold for animals (Idtechex, 2009). Since development in recent years has resulted in small and reliable tags, the agricultural sector is forecast to be the next large sector for the technology. Electronic identification in agriculture is forecast to be worth SEK 66 billion by the year 2017 (NYTeknik, 2009).

### **3.2 AGRICULTURAL PRODUCTION - AREAS OF APPLICATION**

After an extensive search through library resources and databases of scientific articles, the main areas of application were chosen. The main concepts and findings for the different areas are presented in this section in order to establish an overview of what technologies exist and in which areas these technologies are likely to be used in the near future.

#### **3.2.1 Applications for livestock production**

There are four different types of RFID sensors used for animal identification: collar transponder, ear tag, injectible transponder and rumen bolus (Finkenzeller, 2003). These can be used for various purposes, such as tracking, behaviour

research and feed management. Of these different tags, the ear tags are the most promising for livestock applications, since they can be applied to different kinds of animals (sheep, goats, pigs and cattle), whereas the rumen bolus is only suitable for cattle. Injectable glass tags are most suitable for pets, since there are concerns and problems associated with the removal of the tags from livestock carcasses to avoid them remaining in the meat products (Voulodimos *et al.*, 2009).

Traceability is important in the food chain to achieve high food safety and reliable information on origin. The use of RFID tags in animal production not only provides management and welfare benefits, but also increases accuracy in traceability. Manual recording of cattle movements is labour-intensive and the risk of error is fairly high. At present, animals usually have ear number tags. The regulations concerning tagging vary depending on the animal type. For example, ear tags must be applied within 20 days of birth for cattle and within 6 months for sheep and goats, while pigs can be tagged by ear tags or tattoos at latest before departure from the place of birth (Jordbruksverket 2008a,b; 2009a). About 10% of cattle lose one of their two tags and 2% lose both tags. This causes problems in identifying the animals and if the tags are not replaced the single farm payment is reduced (Tractech, 2009a).

Animals carrying a RFID tag can easily be recognised through the logistics chain from farm to slaughterhouse. The only equipment needed is readers placed at strategic positions, such as the loading gate on the transportation lorry and the intake door at the receiving facility. The information from the tag can follow the carcass through the cutting process (Tractech, 2009a). The information from the original tag can be transferred to new labels on the meat packages and once the meat reaches the shelf of a food shop, the information stored on the tag, such as climate impact, transportation, veterinary records, etc. can be displayed for the consumer on a screen (Tractech, 2009b). RFID-based RTLS are already in use in hospitals for tracking and locating people and equipment, which is useful not only in increasing efficiency but also healthcare safety (Awarepoint, 2009).

This technology has potential in animal husbandry. With RTLS the farmer can monitor the movement of the individual animals in the production facility and can track the location of a specific animal if necessary. Such an ability would greatly save labour and time when sorting animals or with veterinary services.

Use of RFID is well established among dairy farms. The cows use a RFID tag placed in a collar, and identification is made at essential choke points, such as gateways and feed stations. According to a study carried out in 1976, the technology was already available at that time (Bridle, 1976). In that study, the reading security was 5998 out of 6000 readings. The major problem was wear and tear of the casing in which the electronic circuit was placed. The transponder technology seemed to be a promising product for automatic reading to replace the identification by punch cards used at that time (Bridle, 1976).

RFID systems could be a useful tool for breeder management. At present there is at least one Swedish company offering an RFID-based product for cattle tracking. In a Canadian experiment where dairy cows were equipped with RFID sensors, a significant reduction (up to 90%) in labour for data collection and recording was

---

observed and the researchers estimated the equipment to have a one-year payback time (Murray *et al.*, 2009).

These systems described above are based on the passive ‘write once, read many’ type of tags. In a study by Athanasios *et al.* (2009), a system using tags with the possibility to overwrite many times was used. The features of this system were the ability to store data, other than ID, on the animal tag. The data were stored in a local database as well as in the ear tag. The local database was connected to a central database from which other farms could retrieve information about the cattle purchased from another farm. This system allows information exchange between farms or any actor connected to the database network. This is possible through use of the write once tags as well, but the benefit of the other system is that important information such as medical records, disease, diet and behaviour can be stored and updated in the tag, so farmers not connected to the network can retrieve the information if they have reading equipment (Athanasios *et al.*, 2009).

To measure social behaviour and interactions, it is of interest to monitor the behaviour of animals with an automatic local positioning system. This was traditionally done by manual observation, but studies on video recording have been made. A real time local radar system working with active necklace tags, provided by ABATEC electronic systems, installed in a house for loose cattle showed an accuracy of less than one metre and was seen as a successful system for animal behaviour research (Gygax *et al.*, 2006).

### **3.2.2 Applications for crop production**

RTLS are used to track goods. Large container terminals have RFID tags to allow their location to be monitored. The number of units in a box can be determined without opening the box if every unit has an RFID tag. This is used to track and locate goods worldwide. An already established technology combined with a large quantity of agricultural goods would have some applications in the agricultural sector.

There has been some research on using RFID tags in batches of grain. This technique is useful in the process of traceability and quality management. It could even be of interest for manufacturers of grain handling machinery, since it can be used for measuring the movement of grain inside dryers, silos and mixers. The system is in principle uncomplicated. A number of RFID tags are deployed into the batch of grain at harvesting. The physical characteristics of the tags are similar to the grain in both size and mass. This is of great importance to avoid separation due to differences in particle size and weight. In an experiment in which RFID tags were deployed into four different batches of grain filled into an experimental silo, the concentration of tags was 2 per kg of grain (Steinmeier *et al.*, 2009). The main findings from this experiment were that 1.33% of the tags were lost and that the probability of error in finding the correct tag in the correct batch was not more than 9%. However in this case, the tags were collected from the batches manually (Steinmeier *et al.*, 2009).

There is often interest in having spatial resolution on harvest. In a study by Ampatzidris & Vougioukas (2009), spatial variable yield maps were created for

---

apples. When harvesting apples or other handpicked crops there are several advantages if the kind of crop in the box or crate is automatically recorded. The ability to do so reduces the risk of errors during logistics and reduces the workload on harvesting staff. In a study in Greece, a trial was conducted in which RFID tags were fixed on the trees and on the crates. The tractor onto which the crates were loaded was equipped with a RFID reader connected to weighing scales. When the worker loaded a crate onto the tractor, the weight was measured and associated with the unique information on the crate tag. The tractor RFID reader also identified the tree the crate was filled from. The information about the type and amount of apples and the trees from which they were gathered was all stored in the computer. In a second similar trial, the RFID tag on the crates was replaced by a barcode tag and a barcode reader was installed on the tractor. The main conclusions were that both systems functioned well but that the RFID tag was more reliable than the barcode tag (Ampatzidis & Vougioukas, 2009).

In precision agriculture it is important to record the time and spatial variability of harvest and also the application of different inputs. There are different ways available to automatically record the amount of fertilizer or spraying chemical applied at a certain location. If the tractor is equipped with a position satellite-aided mapping system, it would be possible to connect this to a reader on a sprayer or spreader that recorded the type of materials applied at a certain location. This would enable the type and the characteristics of the material applied to be recorded, and would form part of the process to establish a spatially and time variable log file for fertilizer or pesticide application. Such a system could work with RF identity tags or with barcodes. This would reduce the pile of papers that have to bounce around in the tractor cab, as well as removing the work load when the information is digitised in spraying records and eliminating the risk of conscious or unconscious error during data transfer (Miller, 1999). Watts (2003) conducted a trial in which a sprayer was equipped with a RFID identification device and a load cell connected to the onboard sprayer computer and satellite positioning system. The system made records of the product and quantity loaded. The study then compared the results of this digital recording with those obtained by traditional methods and found that the loading time with automatic recording was 15 seconds longer than by the traditional method. However, when the manual recording time was taken into account, the automatic system was 4 seconds faster. The data input on the type of product loaded could also be used for automatic alteration of machine settings, but the time required for this was not determined (Watts, 2003).

Irrigation is essential in many valuable crops, and timing of irrigation is a keystone for optimising the returns from irrigation. At present there are about 100 000 ha of irrigated land in Sweden, which require 100 million cubic metres of water. There are several methods to determine the timing of irrigation. The traditional way is to measure precipitation and rainfall and from those data calculate a water budget. However today, computers support farmers with advanced modelling software. There is software available that is aimed directly at farmers and also versions designed for agricultural consultants. However such a system is based on meteorological data and usually does not take into account the local variations in the field, despite the fact that there are several factors that influence the time of irrigation, such as type of crop, root depth, wilting point and

---

field capacity. There are several ways to measure the amount of plant-available water in the soil, the traditional method being to use tensiometers that measure the tension at which water is held in the soil pores. It is also possible to measure the electrical resistance in the soil or to use neutron measurement systems to measure the amount of hydrogen, although such a system is only used for research purposes since it produces radioactive radiation (Jordbruksverket, 2007).

In order to increase the efficiency of irrigation and cut the cost of collecting data manually, a real time wireless sensor array can be used to monitor moisture and temperature data at multiple locations simultaneously in a field. The wireless sensors remove the need for manual collection of data in the field from every sensor, which decreases the labour input and improves the timing of irrigation. The system can be directly connected to the irrigation system to automatically adjust the amount of water applied against the need at specific locations (Vellidis *et al.*, 2007a). In a study by Vellidis *et al.* (2007b), data logger soil moisture sensors combined with active RFID transmitters formed a sensor array. The transmitters, which were active, needed a power source. In the study the source was a 9 V lithium battery, which was enough power for the whole crop season. The tags used had a line-of-site transmission range of 0.8 km. The system is not only technically promising but also economically sound. The price of one node is approximately USD 115 (SEK 800)<sup>1</sup> and the price for a complete system providing complete instrumentation, including 20 nodes, for measuring and reporting data from 40 hectares when launched commercially will be approximately USD 2700 (SEK 18700)<sup>2</sup>. The lifespan of the nodes is expected to be 5 years (Vellidis *et al.*, 2007b). Such a system provides promising scope to reduce water consumption as well as increase crop yield and quality, especially when integrated with a VIR (variable rate irrigation) system (Vellidis *et al.*, 2007b). In a study by Damas *et al.* (2001), a VIR system called HidroBus evaluated on a 1500 hectare area in Spain was shown to have the potential to save up to 60% of water.

In potato cultivation, environmental factors have a large impact on product quality and quantity. An even water supply is important to achieve a product with a good appearance that is attractive to the customer. With an uneven water supply the tubers can start to grow in peculiar shapes and cracks can occur (Fågelfors, 2001). Late blight (*Phytophthora infestans*) causes severe damage and reductions in yield, with field experiments in England and Wales showing an average yield decrease of 30.2% (Bradshaw and Vaughan, 1996). To avoid this, farmers use pesticides once every 5-10 days, which makes up a significant part of the total cropping costs (Chow and Bernard, 1999). The average number of pesticide treatments is 6.6 annually (Thomas *et al.*, 1997). The high costs combined with the potential environmental impact create a need for more a efficient plant protection strategy. To forecast blight outbreaks, data on temperature, rainfall and relative humidity are needed. Such data have been manually collected for over 40 years for blight prognosis but in a study by Chow and Bernard (1999), a fully automated real time potato late blight alert unit was constructed to measure data

---

<sup>1</sup> According to exchange rate 1:6.92 (17/09/2009)

<sup>2</sup> According to exchange rate 1:6.92 (17/09/2009)

---

and process it automatically directly in the field. A visual signal was sent by flashing light when spraying should occur and data were also sent to a central computer for logging and processing. The main findings from that study were that the automated units were better in response time and stability, and cut delays and errors characteristic of manual data collection and processing.

Positioning systems are not new in crop production. They have been used and developed since 1995, when the American GNSS (global navigation satellite system) became available for private use. Systems for mapping spatial variability in fields and guidance have an accuracy down to a centimetre (Lechner and Baumann, 2000). However, the GNSS-based systems are not by definition RTLS since they cannot report data from the tags (in this case the onboard vehicle unit) in real time. Auernhammer *et al.* (1994) studied a system in which yield mapping was executed with GPS positioning and the data were either manually transferred from the combine harvester to a stationary computer or transmitted by radio modem every 7 seconds. This shows that the technology for RTLS in yield mapping has been available for a number of years.

## **4. RESULTS**

To identify the need for the new technology, it is essential to examine the structure in agriculture and to determine the application/s that will have the largest impact on the potential market. An analysis was therefore carried out of the agricultural sector and of the different steps in the production chain.

### **4.1 POSSIBILITIES – THE FINDINGS FROM THE LITERATURE REVIEW**

RTLS is already a well established technology in dairy production and is widely used for precision feeding and cow traffic management, with approximately 60% of Swedish dairy cows being equipped with transponders (C. Ohlsson, pers. comm. 2009). There is a wide range of different potential RTLS applications in agricultural production. As the literature review showed, RTLS can be used in monitoring environmental data such as humidity and temperature and for raising the efficiency of production by optimising the timing and amount of inputs for crop production. RTLS have long been established in logistics and can become so in agriculture for harvest mapping, quality monitoring and traceability issues. There are also applications in which the systems can be utilised to monitor the environment in order to supply data for decisions in irrigation and pesticide use. In animal production, RTLS can be used to raise productivity by more efficient management and increased animal welfare through monitoring the behaviour of animals in order to prevent disease or to increase fertility by determining oestrus before it occurs. RTLS can also be used to track the exact position of animals. In addition to being used on-farm, RTLS can be applied throughout the logistics chain of the farm products. The RTLS applications with the most potential in agriculture according to the literature review are livestock production and electronic identification.

RTLS for crop production seem most suitable for environmental monitoring in microclimate forecast modelling for pesticide application and irrigation

---

management. This is essential for success in growing sensitive high value crops, in order to maintain yield and high homogeneous quality.

#### 4.2 TARGET GROUPS

To determine the areas where applications should first be introduced and those with the largest potential, the parts of the sector with the greatest numbers of potential customers for the product or with the largest quantities or area need to be identified. Different parameters are needed to meet the need from a variety of applications. Some applications can be dependent on the number of consumers and some might be dependent on the production units (animals, hectares or yield).

According to the Yearbook of Agricultural Statistics (2009), the trend in the Swedish agricultural sector is toward fewer and larger production units. The largest target group, by number, in crop production is ley and green crop producers. These crops are grown on 44% of the total arable area. In second place are cereal producing units, which use 41% of the arable area but produce a total yield that is a million tonnes (DM) larger than that of ley and green crops. Oilseed crops, potatoes and sugarbeet are small in terms of area grown and number of growers, although there are twice as many potato growers as sugarbeet growers. Yields per hectare are high for potatoes and sugarbeet, which results in significant quantities. The major vegetable crops in outdoor cultivation are carrot, onion and lettuce, but the number of outdoor growing units is less than 2000 and the branch uses only 0.5% of the arable area, which makes it a small group. Statistical data on the crop production sector in Sweden are presented in Table 2.

*Table 2. Crop data for Sweden: area, yield, number of production units*

	Total yield (tonnes)	Area (ha)	Proportion of total %	Number of prod. units
Ley and green crops	4 115 700	1 160 005	43.6	66 981
Cereals	5 195 000	1 087 722	40.9	32 689
Oilseed crops	264 800	93 040	3.5	5 552
Potatoes	587 700	26 883	1.0	4 736
Sugarbeet	1 974 900	36 778	1.4	2 399
Outdoor vegetables	216 304	12 557	0.5	1 853
Other		243 540	9.2	

Source: Yearbook of Agricultural Statistics (2009).

The largest group of livestock holdings are cattle farms. According to the statistics there are some 22 800 registered companies in this sector, of which 6500 are dairy farms, with a total number of 1.6 million cattle, of which 350 000 are dairy cows. Of the 350 000 dairy cows present today, approximately 200 000 are equipped with transponders (C. Ohlsson, pers. comm. 2009). The number of production units in sheep production is 8200, though the number of sheep is relatively low, about 0.5 million head. There are relatively few companies producing chicken and hens (about 5 500) but the number of animals is high, 7.2 million birds. The pig sector is about the same size as the cattle sector in terms of number of individuals, but the number of production units is only about 2 400. Statistical data on the livestock production sector in Sweden are presented in Table 3.

*Table 3. Livestock data for Sweden: Number of livestock, number of production units*

	Number of livestock	Proportion of total %	Number of companies
Pigs	1 609 289	14.8	2 380
Chickens and hens	7 194 759	66.1	5 497
Dairy cows	357 194	3.3	6 474
Sheep	524 780	4.8	8 186
Cattle, excl. dairy cows	1 201 187	11.0	16 370
Others			40 476

Source: Yearbook of Agricultural Statistics (2009).

### 4.3 ECONOMIC ANALYSIS

It is difficult to give exact economic figures on adopting a technology that hardly exists, though it is possible to give estimations by making sample calculations for chosen production types. The economic gain from applying a technical solution depends on several factors, such as the profit from each unit produced and the gain from optimising the production through the technical solution. When establishing economic calculations for different production enterprises, different production units are used. All production units also have a large difference in turnover, so in order to compare the costs arising when implementing the technology, the relative change in total cost was chosen here. For ear tags on animals, only the cost of the tag was applied and no consideration was taken of the price of the computer-aided management system. The purpose of the calculations that form Table 4 is to show the differences between the different types of production enterprise. Since the cost of a complete system is unknown, but assumed to be the same for all animal types, it is not included.

#### 4.3.1 Livestock production

For livestock production the profit from using animal tags is largely dependent on the profit from each animal. The relative increase in cost is shown in Table 4. The calculations are based on the standard spreadsheets provided by Agriwise, a tool for farm management decisions provided by the Department of Economics at SLU (see section 7.2, Appendix), which uses price information from 2008. Modification of direct cost was carried out in order to add the cost of a standard electronic ear tag. Since electronic ear tags for cattle, sheep and pigs are already available, the current price of those was used, which was set to an average of SEK 20 SEK (OS Id, 2009; G. Nybom, pers. comm. 2009). Since there are no electronic tags available for poultry, the price of such was assumed to be the same as for the ear tags.

As Table 4 shows, applying tags to chickens raises the production costs by 142% if the tags used are the same price as cattle tags. In fattening pig and lamb production, tags give a more reasonable increase in cost of 1.5%. For dairy cows the increase in annual cost is 0.02%. Taking into account strictly economic gains, the benefits from investment in the technology need to balance the increased cost



to be profitable. For dairy cows the introduction of electronic ear tags has the potential to reduce costs by replacing the commonly used transponders, since transponders cost SEK 500 per unit (C. Ohlsson, pers. comm. 2009). Table 4 shows the increase in production needed from the technology in order to balance the cost. This increase is unreasonably high for chicken production, but for other animals it is insignificantly low. Table 4 also shows the input values for the calculation.

*Table 4. Relative change in cost when applying RTLS in livestock production*

Production type	Production unit	Current price (SEK/kg)	Change in total cost	Increase in production needed (kg/prod unit)
Poultry	set /m <sup>2</sup>	7.69	141.89%	53
Slaughter pig	Individual	14.68	1.54%	1
Sheep	/ewe /year	42.39	1.44%	1
Dairy cow	Individual year	3.61	0.02%	2

### 4.3.2 Crop production

For crop production, an RTLS sensor array for environmental monitoring was chosen as a potential solution. Such a system can monitor humidity, soil moisture and temperature and has a cost of SEK 18700 per 40 ha. (Vellidis *et al.*, 2007). Table 5 shows the relative increase in cost when deploying the monitoring system, as well as the increase in yield needed to balance the extra cost. It also shows what the farmer has to gain from better precision in order to pay off the sensor array. These calculations showed that potato and ley were the crops that had the least affected costs and needed the lowest increase in yield. Potato was chosen as the reference crop for further investigation since it is a valuable and sensitive crop and has high demands on irrigation and pesticide use (Thomas *et al.*, 1997; Chow and Bernard, 1999).

*Table 5. Relative change in cost when applying RTLS in crop production*

Production type	Production unit	Current price (SEK/kg)	Change in total cost	Increase in production needed (kg dm/ha)
Potato	/ha/year	1.80	0.26%	87
Ley	/ha/year	2.11	1.45%	74
Winter wheat	/ha/year	0.99	2.49%	158
Spring barley	/ha/year	0.8	3.06%	195

For traceability in crop production, yield determination, mapping and distribution traceability purposes, there seems to be no commercial system available. One possible area of using RTLS in traceability of crops is for the potato crop, since it can be harvested in crates, usually of 1000 kg. The average price of potatoes in 2007/2008 was SEK 2.11 per kg (Agriwise, 2009). This means the value of a crate is SEK 2 110. The price of a passive tag is SEK 10-30 (Table 1). The total cost increase is 0.25% calculated on a tag life expectancy of 5 years and every 1000 kg crate being equipped with a passive RFID tag (Appendix 1). The cost of the reading and data processing unit is unknown, since there is no such available. The

results show that it is economically viable to use RFID tags on potato crates in order to raise product safety and storage management.

#### **4.4 POTENTIAL APPLICATIONS FOR SWEDISH LIVESTOCK PRODUCTION CHAIN**

Electronic ear tags have problems compared with necklace transponders, however. The tags can get caught and ripped off the ear (N. Persson, pers. comm. 2009). There are no clear ambitions to introduce electronic identity tags as compulsory, but in EU countries with the national herd exceeding 600 000 sheep and goats, it is compulsory to use such tags. Since Sweden falls short in numbers of sheep and goats, use of the electronic system is voluntary. There is no EU legislation regarding electronic tags for cattle, but it is under consideration and the outcome is expected to be a voluntary use (N. Persson, pers. comm. 2009). However, the question is controversial since the electronic tags are more expensive than the existing tags. When using EID (electronic identity), it could be possible to have more automatic data transmission between the farm and the national animal registry. The expectation from the official point of view is that this is a costly system and would probably not be utilised unless it is made compulsory. External tags such as the ear tags will most probably be used. The injectible chip would be less popular, since this can migrate and become difficult to find at slaughter (N. Persson, pers. comm. 2009). A large amount of information can be stored in a tag, although the most likely outcome is that only identity will be stored in the tag and other information will be stored in management programmes or similar, since such systems provide a higher degree of transparency.

##### **4.4.1 Management**

The electronic identification of dairy cows by RFID technology was evaluated in 1976 with successful results (Bridle, 1976). The concept of a necklace with an identity tag has been used since then for dairy cows. Today different companies use different technologies to achieve the same function, automatic identification. The company DeLaval uses RF tags incorporated in a polypropylene casing. These tags are used for cow identification, feed management and selection. Oestrus detection needs an additional device (C. Ohlsson, pers. comm. 2009).

The German producer LELY uses IR (infra red) signals for communication between the object and reader, though this system has the capability to monitor cow activity and rumination by an acceleration sensor (LELY, 2009). With the help of the transponder the farmer can track the animal and the computer software can automatically determine whether a cow should have access to a certain place in the house, e.g. the milking robot or feeding stations. Such a system uses identification at different choke points, selection gates or feeding stations. The system can also keep a record of the movement pattern and activity of the cow in order to return a notification to the farmer if a cow is showing oestrus or symptoms of illness. Neither the Lely nor the DeLaval system can determine the exact location of an animal, since the systems only use location at choke points.

In an American system, Grow Safe Beef™, the farm is equipped with an RTLS that monitors the weight of the animals at the water trough by partial body weight

---

measures. The animals are tagged by passive RFID tags which are recognised by the weight measuring equipment. When an animal reaches slaughter weight the system automatically colour-marks the hide. According to the company that produces it, this system improve income by SEK 500 per head (Growsafe, 2009). However there is no such system in use in Sweden for beef cattle, although according to Göran Nybom at Tractech Company, which provides and develops solutions for traceability to different branches, there is a system under development that can be used for beef production. The Tractech system is based on standard EID tags and has a relatively low cost and aims more at traceability through transportation and the slaughter chain than at farm management. However, the system can aid farmers in their management since the transportation of animals from the farm is automatically recorded and reported to the authorities, so this is a step that reduces the paperwork as well as reading errors when selling animals. The reading security of the tags is dependent on the radio frequency used. According to Göran Nybom at Tractech, in the early version that used low frequency tags the reading safety was too low, but now UHF signals are used and the readings are satisfactory.

The reading safety from the UHF tags is close to 100% and the price of such a system is approximately SEK 20 for the standard tag and computer software and readers cost SEK 10 000 depending on the scope (G. Nybom, pers. comm. 2009). Just recently a system was released (CowDetect) for dairy herd management that can actually locate the precise position of a cow with an accuracy of centimetres. (Anonymous, 2009). However, this system does not work with passive tags, but has an active tag with a battery replacement time of 3 years.

#### **4.4.2 Behaviour research**

In behaviour research, RTLS would be useful to farmers if it could be used to trace the location of individuals, giving the opportunity to measure activity in order to supervise heat or health problems. According to Per Peetz Nielsen, from the Department of Animal Nutrition and Management at SLU, it is clear that there is a need for automatic positioning of animals, at least for scientific purposes. He is conducting an experiment which aims to determine whether cows need shade during sunny days, as there is no reliable and functioning system for this available at present. Although a GPS positioning system could be used, at present it would be too expensive if it had to be applied to every individual in a herd. Furthermore, the GPS system available is too inaccurate and needs free line-of-sight, which means it is not useful inside a cattle shed or in dense forest. According to Kristina Lindgren at JTI, who is working with GPS sensors on cows, the GPS system is not as easy to work with as desired. In research carried out at JTI, the GPS system was bought from Vectronic Aerospace and their cheapest version costs SEK 11000 per unit (Vectronic price list, 2009). This system reads and stores positional data in the collar, which needs to be taken off the animal in order to transfer data.

The GPS system is still too expensive and difficult to work with for applications in large-scale research trials or commercially on farms. This is why RFID could have significant potential in these applications. Such a system could be of great use in animal behaviour research and it could also be used to evaluate the design

---

of farm buildings by recording movements of cattle and preferred places for eating and lying (P.P. Nielsen, pers. comm. 2009).

#### **4.4.3 Application at abattoirs**

From interviews with the major Swedish farmers' abattoir cooperative Scan and its collaborative company Ugglarps, it emerged that not much work has been done in the traceability chain as regards applying electronic identification in transportation. Scan, which is the largest actor on the market, does not use any electronic identification system, though Ugglarps has set up a trial together with the company Hencol, which provides electronic identification and management systems (J-A. Sundelöf, pers. comm. 2009). Scan has just recently installed vehicle computers in its animal transport lorries to reduce the paperwork with transportation documents and get more efficient connection between the abattoir and the lorry, but this system does not include automatic animal identification. (K. Svensson, pers. comm. 2009).

Abattoir representatives reported the electronic identification system to be beneficial not only in reducing work load but also in reducing animal stress while identifying the ear number tags.

### **4.5 POTENTIAL APPLICATIONS FOR SWEDISH CROP PRODUCTION**

#### **4.5.1 Environmental monitoring**

The establishment of an irrigation regime requires the collection of environmental data such as precipitation and temperature. Such data can also be useful for creating forecasts and disease warnings, as well as spatially variable maps of pesticide application rates. The technology of wireless remote soil sensors has recently been developed. Such a system supports farmers with real time data on desired parameters such as temperature and humidity. It can also be utilised to create computerised models for irrigation scheduling. Today it is not common for farmers to use tools such as computer-aided models in general (P. Malm, pers. comm. 2009). He noted in interview that farmers generally determine the timing of irrigation by relying on their own instincts or by testing the soil moisture content using a spade.

There are forecasting products in use in Denmark, though estimates show that the Swedish market is either too small or not yet ready for large-scale adoption of such technology (P. Malm, pers. comm. 2009). The forecast models are one way of using water more efficiently and could be complemented by soil sensors. However, since there is little pressure on Swedish farmers to apply methods for efficient water usage, it will probably take time before such a system is accepted by the market. The most valuable crops are the most important to keep irrigated, although irrigation is not only a matter of maximising yield, but also quality and size. An potato field can lose 500 kg in growth per day if there is insufficient water available. As vegetable producers often have contracts to deliver a certain amount on a daily or weekly basis, one way to regulate growth to meet these criteria is to regulate irrigation (P. Malm, pers. comm. 2009).

---

The ability to regulate irrigation for specific needs at different locations in the field would probably be beneficial for such growth regulation.

For research it is favourable to have an automatic system providing data with time resolution, since today most research is conducted with only spatial resolution. Data with time resolution could be beneficial for research on e.g. nutrient leaching behaviour or gas emissions from agricultural land over the season (J. Arvidsson, pers. comm. 2009).

#### **4.5.2 Traceability**

There are various applications of traceability in crop production, all depending on the type of production. It is possible to use RTLS for tracing inputs such as fertilizers and pesticides and outputs such as crop products. Experiments show that it is clearly possible to equip pesticide containers or fertilizer bags with tags. This enables automatic storage inventory, as well as automatic recording once loaded in the machine for field application. However, there are no clear ambitions from the fertilizer suppliers to introduce electronic tagging of their fertilizer bags. Yara is the largest fertilizer supplier on the Swedish market and according to their product flow manager Mats Karlsson, visual marking of bags is fully sufficient for their own distribution since a bag is wrongly distributed only once every 500 000 tonnes (M. Karlsson, pers. comm. 2009).

Yara have had discussions about introducing RFID labelling in order to establish automatic storehouse inventory, but unfortunately the benefits from such a system were not considered sufficient to overcome the cost of investment, and a major problem was attaching the labels to the plastic material used to make the fertilizer bags, which has a rough texture (M. Karlsson, pers. comm. 2009).

Agricultural products can be equipped with sensors. Crates of fruit and vegetables are examples of this. Variations within a potato field are known to affect the quality properties of potato tubers. Therefore it would be of interest to tag potato crates at harvest to achieve accurate storage handling (F. Fogelberg, pers. comm. 2009). Trials to put sensors in bulk products such as grain have been tested successfully, although the removal from the grain of such sensors was not complete.

#### **4.5.3 Security**

Applying RTLS on a farm can have other beneficial advantages than purely productive ones. According to Göran Nybom of Tractech, on large farms where there is a large number of staff, it could be useful to give certain people access to certain places or to add tags on valuable goods in order to track their location. Such systems are already used on construction sites, in hospitals and by major companies.

---

## 4.6 CONCEPTUAL SOLUTIONS

### 4.6.1 RTLS in livestock production chain

Whether RTLS is applied for dairy, beef, pig or lamb production, the concept of the system applied is similar. Figure 2 shows the information flow in an integrated conceptual system where connection is established between farm, industry, authorities and scientists. The conceptual solution can be diversified into several spheres of application. On the farm RTLS monitors the movement pattern of each EID-tagged individual. This opens the possibility of combining feed management and cow traffic together with oestrus and physiological disorder detection into one system. According to Christina Ohlsson, solutions manager at DeLaval, this would be a beneficial function since it is currently achieved by separate systems. It could be combined in a herd management tool which helps the farmer managing the herd. In the long run, the management software could be connected to the abattoir for supplying information about e.g. slaughter scheduling and reporting. Such a system could also report automatically or semi-automatically to the central animal database when animals are loaded into the slaughter lorry or other off-farm transport, or to other controlling or certification units (G. Nybom, pers. comm. 2009). The system also allows for automatic indoor climate regulation when connected to the animal housing climatic control system, which can be regulated on basis of the animal herd behaviour. Data acquired from private or experimental farms can be used for scientific purposes such as animal behaviour studies and evaluation of construction design when developing new buildings or interior fittings. Such real time positioning data collection would be of great interest for animal scientists. The connection from farm to abattoir is functionally ready to use, but the major abattoir contacted in this study had hardly heard about such technology and is not likely to introduce it in the near future. At farm level there are different systems in use, for dairy cows and pigs there are feed management systems as well as heat detection systems, although these systems are separate. The connection from farm to authorities could be established once the system is deployed at the farm.

---

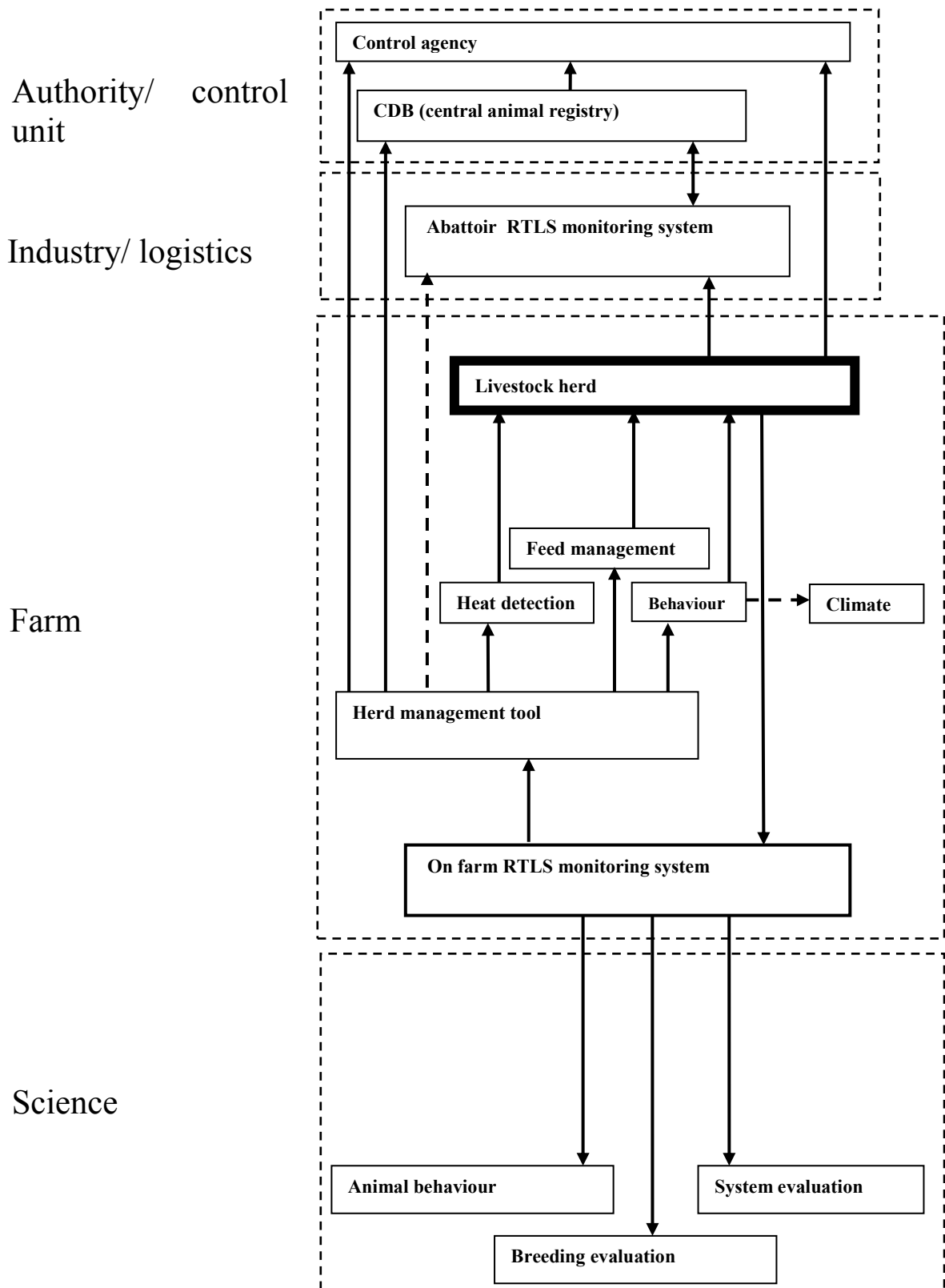

Figure 2. Flow chart showing information handling system for livestock production.

#### **4.6.2 RTLS application in crop production chain**

An integrated RTLS adapted for crop production would differ from that suitable for animals. In the crop production systems the monitoring units are often pre-located stationary units, which return real time measured data. One such integrated system is shown in Figure 3.

The RTLS can be deployed in a field or in different fields at the farm. The sensors placed in the field measure and transmit spatial variable data such as precipitation, temperature, soil moisture and wind speed. The data collected can be processed by management software which calculates water balance and/or calculates the risk of disease outbreak, in order to notify the farmer when field operations such as irrigation, pesticide application or fertilizer application should take place. Since the manual collection and processing of such data is time-consuming, an automatic system is of interest since delay in such operation can reduce yield significantly (P. Malm, pers. comm. 2009)

Storage and movement of inputs as well as automatic recording and identification at field application can be monitored if the containers of products are equipped with RFID tags (Miller, 1999; Watts *et al.*, 2003). Post-harvest, RTLS can be utilised to follow batches in the logistics chain for traceability, as with traceability in meat processing. This can be utilised not only to monitor the transportation but also to establish a yield map in order to adjust the next year's fertilizer application with spatial variability. It also can be used to increase quality management, since products with lower storage capability can be sold earlier (F. Fogelberg, pers. comm. 2009). Such a system is most likely to be used in a distribution chain for unpeeled table potatoes as the in-field variation is no problem in e.g. large-scale crisp manufacturing due to the large quantities (L. Andersson, pers. comm. 2009).

---



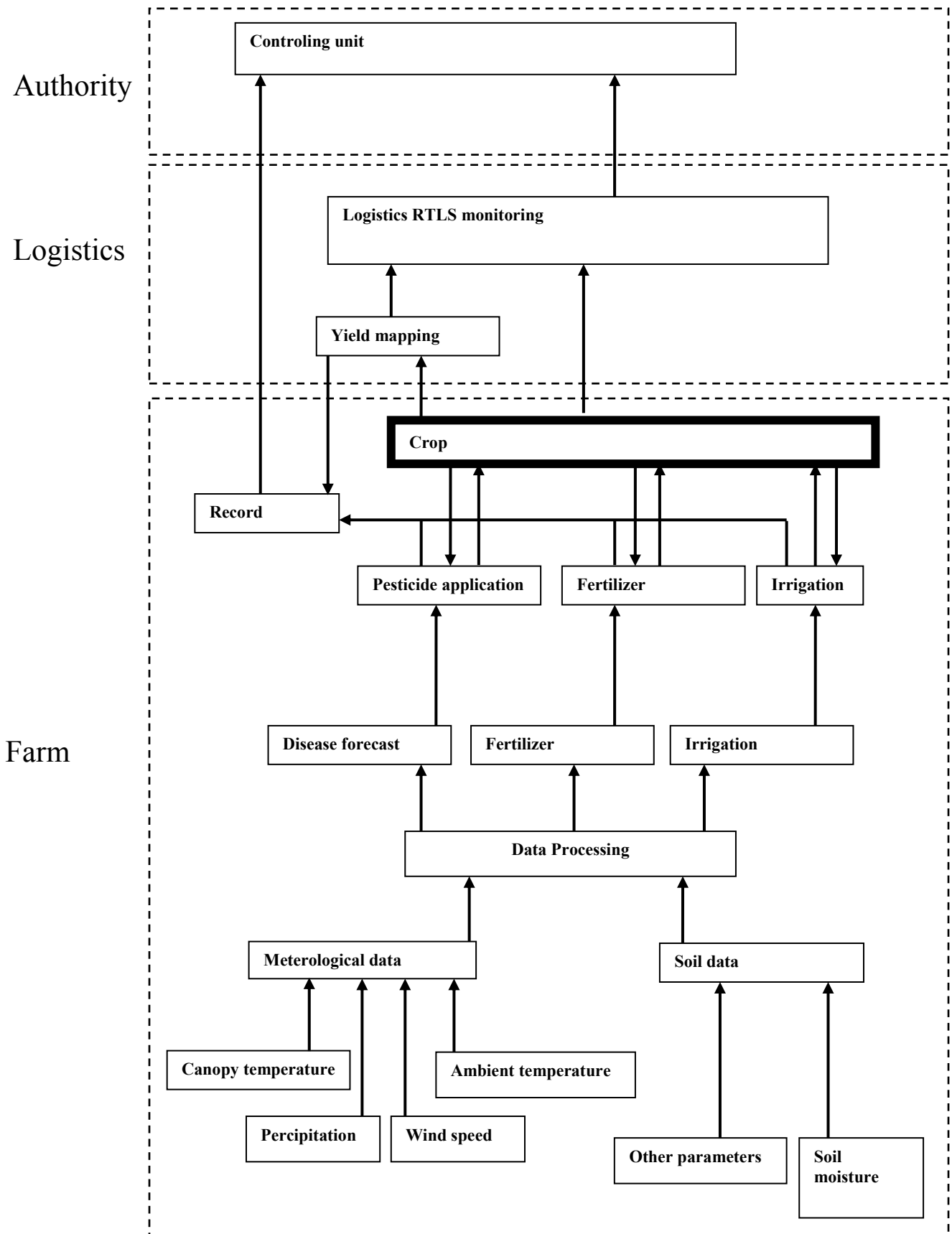

Figure 3. Flow chart showing information handling system for crop production.

## 4.7 TECHNICAL DESCRIPTION OF EQUIPMENT

### 4.7.1 Technical description - RTLS for animal monitoring

The system used in animal production not only needs to withstand the mechanical stress caused by the animal, but also the environment in which the animal lives. This can of course vary greatly between different housing systems. The Swedish animal welfare law stipulates maximum values for a number of gases in the air, as well as maximum relative humidity. The equipment needs at least to withstand the environmental factors shown in Table 6.

Table 6. Limit values in animal houses

	max level
Ammonium (ppm)	10
Carbon dioxide (ppm)	3000
Hydrogen sulphide (ppm)	0.5
Organic dust (mg/m <sup>3</sup> )	10

Source: Jordbruksverket, 2008.

The maximum permissible level regarding relative humidity varies not only between warm and cold houses, but also with the ambient air temperature. The maximum relative humidity for an insulated building is 80-90% depending on the temperature. For an uninsulated livestock building the limit value is 10 units above the value outside the building. These limits are the same for cows, sheep, goats and pigs. There are no regulations about temperature (Jordbruksverket, 2008), and therefore it is likely that the equipment should be able to withstand normal ambient temperature. The lifetime of the tags used needs to be at least the life time of the animal.

Since a large number of cows are already equipped with transponders, the market is adapted to the technology. There is a need for technology that can locate cows precisely in the house in order to determine the activity of animals and detect heat or illness. Such a system could also be integrated in feed management. In the following text, a house for dairy cattle is chosen to explain the demands on the equipment. The construction of a cattle house is different from case to case. Today all cattle houses in Sweden are built as loose houses, since tying cattle in stalls was abolished in 2007 by animal welfare regulations (DFS 2007:5). The loose house is usually built around a steel or wood frame, usually without internal pillars. The roof is usually made of galvanised iron and walls of wood or adjustable screens. The structure is built on a reinforced concrete slab. The interior fittings consist of steel tubes and plywood or plastic. Feeding troughs and feed stations are normally located within the free stall, while milking can be done in a milking parlour situated within the cubicle house or in a separate house (Kostallplan, 2009). A section drawing is shown in Figure 4.

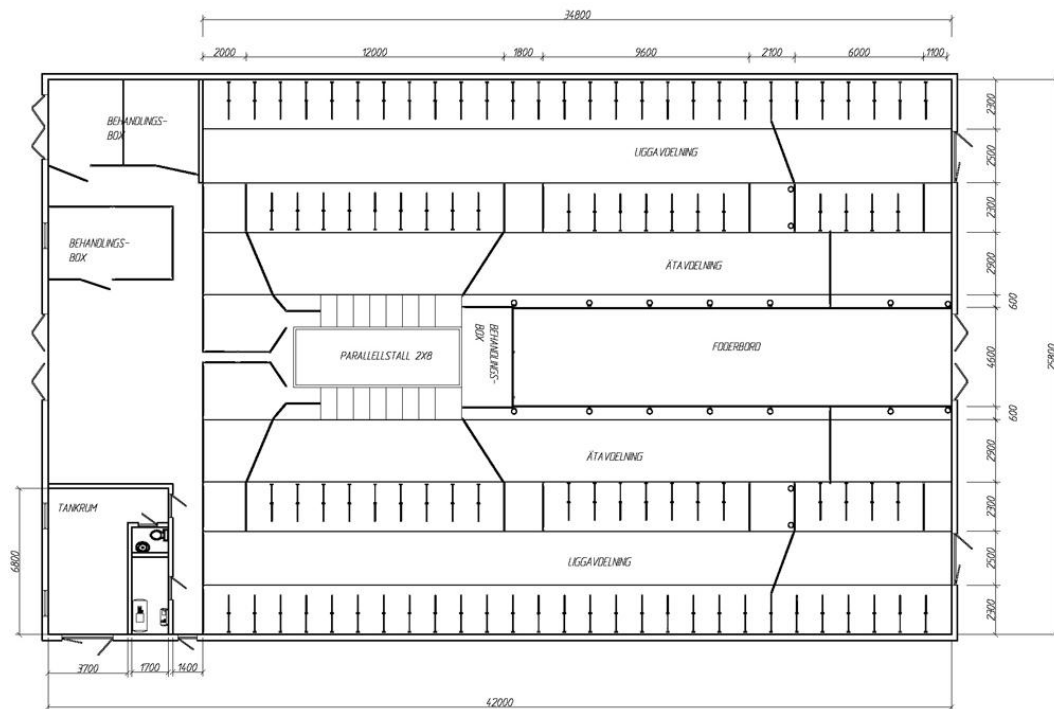

Figure 4. Section drawing of a loose house for dairy cows. (Björn Forss, DeLaval International, with permissions)

The RTLS needs to be able to locate the absolute position of the individual in the house, e.g. in the pre-milking holding pen or milking parlour. Since the feed stations are usually located in cubicle spaces, the system must be able to locate whether the cow is in the feeding station and determine that the cow sleeping in the cubicle next to the feeding station is not inside the feeding station. Figure 5 shows the layout of a system with exact location of ear-tagged animals.

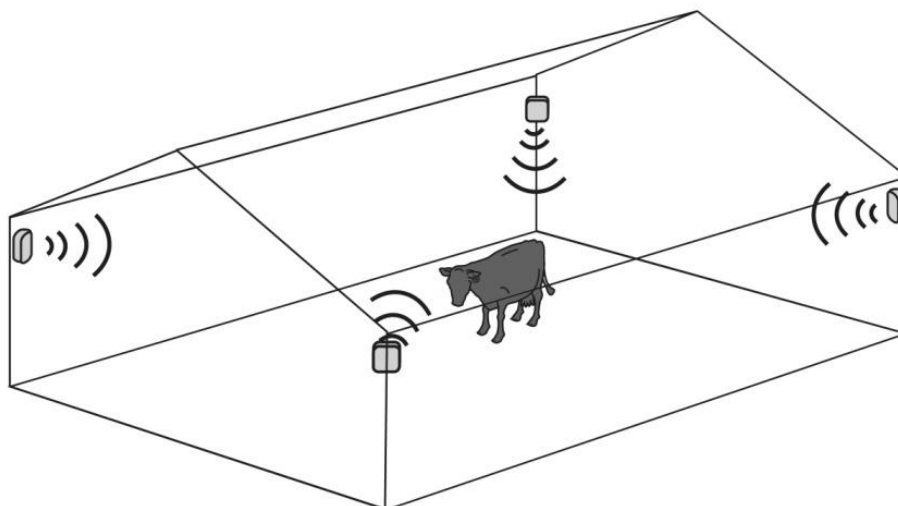

Figure 5. RTLS - Animal monitoring by absolute positioning with sensor array. (Kim Gutekunst, JTI, with permissions)

Similar specifications are necessary in the milking parlour if a system with automatic milk yield recording is used. Since cattle can exert strong forces on interior fittings (P.P. Nielsen, pers. comm. 2009), the parts of the system that can come in contact with animals need to be rigid enough to withstand the physical pressures from cattle that may occur. The positioning system must also be able to return an exact positioning without disturbance from the interior fittings or from cows within the line of sight, in other words the signals must be able to pass through steel tubes, wooden boards and plastic materials, as well as bone and meat, without significant disturbance. The area of surveillance could be different from case to case, though a reasonable area could be 500-1000 m<sup>2</sup>, as shown in Figure 4.

#### **4.7.2 Technical description - soil sensors**

For soil sensors the technical demands differ from those on sensors for animals. In a soil sensor array the tags or sensor units are stationary and report data in real time or at desired intervals to a processing unit. The research units used are all aboveground units (Vellidis *et al.*, 2007), since most crops are harvested at least annually or several times per annum, and fields are cultivated every year for annual crops (Fogelfors, 2001).

The aboveground sensor units need to be removed from the field to avoid damage from farming operations. In order to avoid this, underground units are preferable (Huang *et al.*, 2008). Ploughing is normally done to a depth of 20 cm (Batley, 1988). A suitable depth in the soil profile for deploying the sensors would be at least 30 cm below the soil surface. Figure 6 shows the layout of an underground sensor array (Huang *et al.*, 2008; J. Ekelöf, pers. comm. 2009). The sensor unit needs to withstand mechanical wear and tear factors such as freezing and thawing and soil compaction by heavy machinery, which is common in mechanised agriculture (Hamza, 2005). Freezing and thawing can also cause upward vertical movement of stones through the soil profile (Viklander, 1998). These stones can impact on the sensor unit, but the upward forces can also lift the unit itself. Objects in the soil, such as the sensor unit, can move as much as 1 cm per year (Broadbent, 1979). Furthermore, the electronics in the unit need protection against moist conditions, since fields can be periodically waterlogged.

---

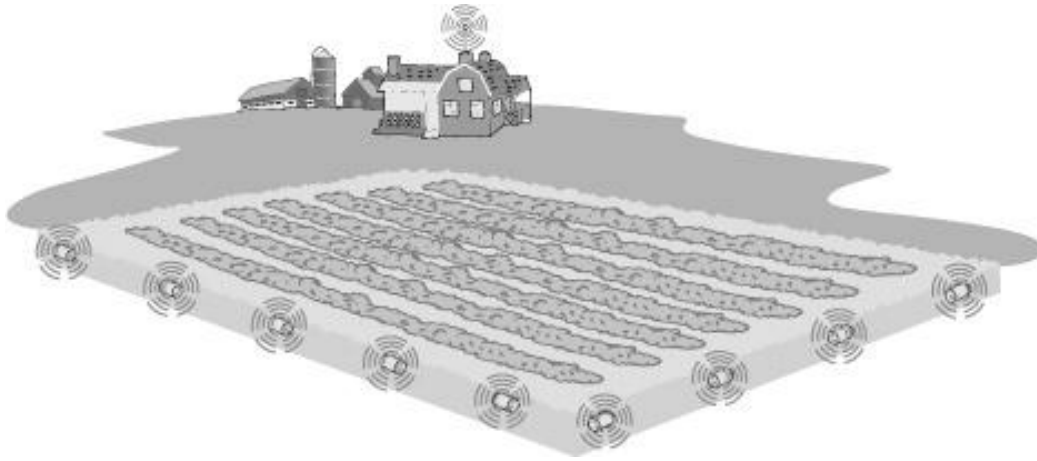

Figure 6. RTLS soil sensor array. (Kim Gutekunst, JTI, with permissions)

For environmental monitoring, sensors need to be aboveground or partly aboveground in order to measure factors such as wind speed, canopy temperature and sun radiation. The number of sensor units per area strongly affects the cost of the array. The array density is strongly parameter dependent, e.g. to explain at least 90% of variation between sites, the density for measuring minimum temperature, relative humidity, solar radiation and evapotranspiration is 30 km distance between nodes. For precipitation the same value is 5 km between nodes (Hubbard, 1993). This shows that an array consisting of one node per two hectares, as used in the experimental set-up by Vellidis *et al.* (2007a), is more than sufficient. The sensors need to be rigid and lightweight, since they have to be collected from the field by hand before harvest.

#### 4.7.3 Technical description - RTLS for yield mapping

The RFID tags used for yield mapping should be attached to the containers in which harvested potatoes or other crops are placed on harvest in the field. The tags need to store the information provided from an onboard GNSS system that writes the positioning coordinates onto the tag. The information on the tag is used throughout transportation so that in the storehouse it is possible to find a crate harvested at a specific location. Since the crates are reused from year to year, it should be possible to reset the tags in order to store new coordinates in the following year. The system needs a RFID reader/writer which transfers the information from the GNSS input onto the tag. It also needs readers in the storehouse and on transportation vehicles that can at least locate the tags at choke points. The reading distance needs to be one or several metres. To ensure satisfactory reading, the system should be able to read through a crate of potatoes from a distance of approximately 1 m without significant loss of signal strength. Figure 7 shows a schematic description of such a system.

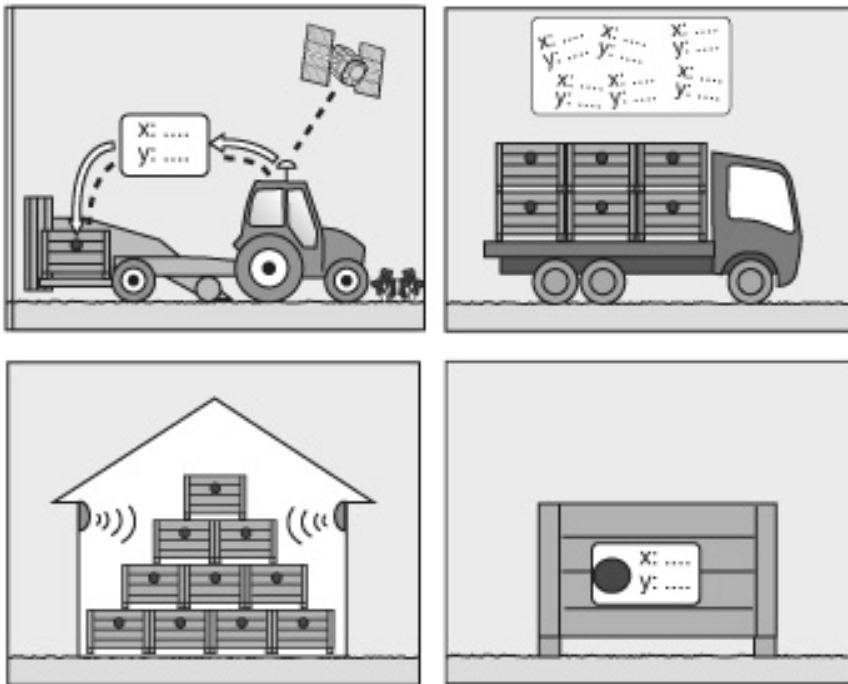

Figure 7. RTLS post-harvest traceability system. (Kim Gutekunst, JTI, with permissions)

## 5. DISCUSSION

There are several areas where RTLS are beneficial for managing agricultural production. They can be used for replacing old systems, combining systems or creating systems for new useful applications. Some applications need more refined technology and some is directly adaptable.

### 5.1 APPLICATIONS IN LIVESTOCK PRODUCTION

The results and literature study clearly indicate a trend for the use of electronic tracking of livestock. A system to be used for logistics purposes in animal transportation systems has already been developed, though it has not yet been widely taken up within the sector. Since the system is based on EID ear tags, the animals need to be fitted with these. A critical factor for the use of EID is that farmers gain something from it, since it is not likely to become compulsory in Europe except for sheep. Necklace transponders, which today are used for feed and herd management, could be replaced by the ear tags.

During the period in which the present study was carried out, a system for RTLS with exact location for use in animal herds was released (Anonymous, 2009). This system makes it possible to combine systems for feed management, herd management, heat detection and behaviour monitoring into one system, which reduces the number of technical systems on the farm. The system works with active battery-powered tags. Development of a system with passive tags would be of great interest and could form the basis of an integrated automated traceability system from farm to customer. The dairy sector is not the largest livestock enterprise in Sweden, but since it already has such systems it is most likely to be the pioneer in adopting new technology. Therefore the first version of RTLS

should be developed for dairy farmers. It could then be applied to practically any livestock where it is possible to attach an identity tag.

A system developed for use on farms would need to withstand hard environmental conditions, as well as mechanical stress and a corrosive environment. The signals used would need to be unaffected by the steel tubes used in cubicles, gates and other interior fittings.

At farm level, a local measurement system for tracking cows would involve:

**Feed management:** The system records the amount of feed intake of the individual on every visit to the feed station in order to ensure that it correlates to the feed plan. A daily amount is set and if the animal reaches the maximum limit no more feed is provided when animal enters the feed station. For this purpose the system needs high time resolution and high positioning accuracy.

**Herd management:** The system records the movement of animals and regulates their movement by opening and closing gates to allow the animal access to certain parts of the house. High time resolution and high positioning resolution are required.

**Heat detection:** The system records the movement pattern of the animal to observe differences from the normal, with a high activity indicating oestrus. For this purpose the system needs lower time resolution and lower positioning accuracy.

**Behaviour monitoring:** The system monitors the movement pattern of animals. For this purpose the system needs similar accuracy as for heat detection.

**Exact location:** A tool, e.g. a pocket computer, is used in order to find individuals in a herd. This would be of greater importance in large herds of animals. Time resolution needs to be relatively high, as well as positioning accuracy.

The creation of a system which can combine these five functions would be a reasonable product. Such a system is of high interest for scientists and industry (both manufacturing and processing). From the literature it is clear that adoption of RTLS in livestock production would have potential benefits, although data on the financial gains from such a system are limited. Therefore a system needs to be developed for further studies in order to convince a future market.

A system for automatic real time location determination would appear to be useful in many applications for livestock handling and it probably has several possibilities that have not yet been discovered.

## 5.2 APPLICATIONS IN CROP PRODUCTION

Sensors in an outdoor irrigation system must be able to withstand factors such as wind, sun, water and temperature variations, but also mechanical stress and animal damage. The equipment also has to be able to measure the moisture at the right depth in the soil for different crops and soil types. The use of moisture sensors in irrigation management has the potential to save large amounts of water,

---

which is a scarce resource in some areas of the world (although not normally in Sweden). Since there is little official pressure on Swedish farmers to introduce water-saving technology, it will probably take time for the market to implement technology such as the irrigation scheduling system, despite the low investment costs as shown by the calculations in section 3.3. Systems where irrigation as well as disease forecasting can be achieved would appear to be possible with the present technology, although the area of application is relatively small on the Swedish market. Knowledge about the use of such tools is limited and more research is needed on appropriate measurement methods and forecast models for Swedish conditions. A system for environmental monitoring can reduce labour and time for data collection and analysis. Such a system has potential benefits in reducing water consumption, pesticide usage and leaching, which in turn can reduce the negative impact of agriculture on the environment.

Current knowledge of spatial variability and array density is limited and further studies are probably needed to determine the optimal distance between the nodes. The existing data show that a relatively low density gives a high accuracy, although the situation is likely to differ in a heterogeneous landscape.

Yield mapping by RFID tags and subsequent tracing of the batches has proven successful on apples, but fruit production is a relatively small business in Sweden. As crates are often used for potatoes and other vegetables, this could be a potential branch for a yield mapping system, at least among smaller farms. The yield mapping system could be integrated into an RTLS production and distribution chain for monitoring traceability.

The implementation of storehouse recording systems and field recording of inputs is dependent on the use of RFID tags on packages by producers and distributors. There has been no dedicated research to date on the introduction of such a system on fertilizer bags, although it will probably be introduced in the future as the technology grows and the cost of the system decreases.

The use of RTLS in grain handling is technically possible, but since there might be residual sensors left in the product, it is probably not suitable for grain used for food or feed. However, it can have a place in the manufacturing industry, where micro nodes are deployed in the batch of grain in order to investigate and evaluate flow behaviour in grain storage, transportation and drying facilities.

## **6. CONCLUSIONS**

The RTLS concept is relatively unknown among agribusiness people and research on such systems for agriculture is scarce.

There are several areas where RTLS can be applied. More work is needed to develop products for such applications.

RTLS have been used in dairy cow management for many years, so a modern system is most likely to be adopted by such producers.

---



For larger livestock farms, RTLS can be successfully utilised for monitoring and feed management, but individual tagging of chickens would be too expensive. A system that records animal movement by exact positioning and which can integrate feed management, behaviour monitoring and herd management into one unit has large potential and it seems reasonable to devote efforts to developing such a system.

RTLS for traceability in logistics is perceived by abattoirs as having potential, but they require more convincing evidence of the reliability of such systems.

In crop production, RTLS could be most successful in environmental monitoring for irrigation and disease management, but could also be used in yield mapping and quality management, and traceability in post-harvest handling of crops.

RTLS can be used for several other purposes such as fertilizer recording and storage management.

The RTLS technology is expanding and in agriculture it can become widely used as society's demands on traceability and management increase.

---

## 7. REFERENCES

### 7.1 LITERATURE

- Ampazidris Y.G., S.G. Vougioukas. 2009. Field experiments for evaluating the incorporation of RFID and Barcode registration and digital weighing technologies in manual fruit harvesting;
- Athanasios S. Voulodimos, Charalampos Z. Patrikakis, Alexander B. Sideridis, Vasileios A. Ntafis, Eftychia M. Xylouri. 2009 A. complete farm management system based on animal identification using RFID technology; Computers and electronics in agriculture xx.
- Auerhammer H., M. Demmel, T. Muhr, J. Rottmeier, K. Wild. 1994. GPS for yield mapping on combines; pp 53-68 Computers and Electronics in agriculture 11
- Batley T. Soil husbandry. 1988. ISBN 0951360507;
- Bradshaw N.J., Vaughan T.B. 1996. The effects of phenylamide fungicides on the control of potato late-blight (*phytophthora infestans*) in England and wales from 1978-1992; Plant pathology 45, pp 249-269;
- Bridle J.E. 1976. Automatic Dairy cow identification; Journal of Agricultural Engineering Research 21; pp 41-48.
- Broadbent, N. 1979. Coastal resources and settlement stability, a critical study of a mesolithic site complex in northern Sweden. Archaeological Studies, Uppsala Univ., Institute of North European Archaeology, Aun 3.
- Chow T.L., G. Bernard. 1999. A versatile fully automated, real-time potato late blight alert unit; pp 55-69 Computers and electronics in agriculture 23
- DFS 2007:5; Djurskyddsmyndighetens föreskrifter och allmänna råd om djurhållning inom lantbruket m.m.; 2007; ISSN 1652-3040
- Damas M. Prados A M. Gomez F. Olivares G. Fiend bus for integrated management of extensive areas of irrigated land, Spain, 2001
- Finkenzeller K. 2003. RFID handbook, fundamentals and Applications in contactless smart cards and identification, Sussex, England, ISBN 0-470-84402
- Fogelfors H. 2001. Växtproduktion i jordbruket. ISBN 91-27-35292-7
- Gygax L., G. Neisen, H. Bollhalder. 2007. Accuracy and validation of a radar-based automatic local position measurement system for tracking dairy cows in free-stall barns; pp 23-33; Computers and electronics in agriculture 56
- Hamza M.A., W.K. Anderson. 2005. Soil compaction in cropping systems A review of the nature, causes and possible solutions; pp 121-145; Soil & Tillage Research 82
-

- 
- Huang J., Kumar R., Kamal A. E., Weber R. J. 2008. Development of a wireless soil sensor network; ASABE Meeting presentation, paper no: 080025.
- Hubbard K.G. 1993. Spatial variability of daily weather variables in the high plains of the USA
- Jordbruksverket 2007; Jordbruksinformation 5-2007; Bevattning och växtnäringsutnyttjande; Sweden
- Jordbruksverket 2008; Jordbruksinformation 12-2008; Djurskyddsbestämmelser nötkreatur; ISSN 1102-8025
- Jordbruksverket. 2008a. Märkning, journalföring och rapportering av grisar
- Jordbruksverket. 2008b. Märkning och registrering av får och getter
- Jordbruksverket. 2009a. Märkning och registrering av nötkreatur
- Jordbruksverket. 2009. Yearbook of agricultural statistics 2009; ISSN 1654-4382; Sweden
- Lechner W., Baumann S. 2000. Global navigation satellite system; pp 67-85; Computers and electronics in agriculture 25
- Malik A. 2009. RTLS For dummies, Wiley publishing, Indianapolis, ISBN 978-0-470-39868-5
- Miller P.C.H. 1999. The International Fertilizer Society (IFS); Proceedings no. 439; Automatic recording by application machinery of rates and spatial distribution of field inputs; York, UK; ISBN 0 85310 074 8
- Murray B.B, I. Rumbles, J. Rodenburg; Application of RFID technology in herd management on dairy herds in Canada; pp 259-265 Precision livestock farming '09, 2009; ISBN 978-90-8686-112-5
- Steinmeier U., D. von Hoersten, W. Luecke. 2009. Flow behaviour analysis of a RFID-tracer for traceability of grain; pp 403-411 Precision agriculture '09, 2009, ISBN 978-90-8686-113-2
- Thomas M.R., Garthwaite D.G., Banham A.R. 1997. Pesticide usage survey Report 141. Arable farm crops in Great Britain 1996. Ministry of Agriculture, Fisheries and Food, London
- Vellidis G., M. Tucker, C. Perry, C. Kvien, C Bednarz. 2007a. A real-time wireless smart sensor array for scheduling irrigation; Computers and electronics in agriculture 61 (2008) pp 45-50;
- Vellidis G., V. Garrick, S. Pocknee, C. Perry, C. Kvien, M. Tucker. 2007b. How wireless will change agriculture; pp 57-67; Precision agriculture '07; 2007; ISBN 978-90-8686-024-1
- Watts A.J., P.C.H. Miller, R.J. Godwin. 2003. Automatically recording sprayer inputs to improve traceability and control; The BCPC International congress-Crop Science & Technology 2003; Glasgow, Scotland; ISBN 1901396630
-

## 7.2 INTERNET SOURCES

- Agriwise 2009; databoken, potatis;  
<http://www.agriwise.org/databoken/databok2k9/databok2009htm/index.htm>
- Awarepoint; [www.awarepoint.com](http://www.awarepoint.com)
- Tractech 2009a; [http://www.tractechnology.se/files/MeatTracBreeder\\_SWE.pdf](http://www.tractechnology.se/files/MeatTracBreeder_SWE.pdf);  
2009-09-14
- Tractech 2009b;  
[http://www.bequoted.com/investor/company/documents/trac\\_press\\_071207.pdf](http://www.bequoted.com/investor/company/documents/trac_press_071207.pdf);  
2009-09-15
- Vectronic pricelist, 2009
- OS ID 2009; Product catalogue, price list nov 2009; OS ID, OS i Österdalen
- Idtechex;  
[http://www.idtechex.com/research/articles/rfid\\_market\\_forecasts\\_2009\\_2019\\_00001377.asp](http://www.idtechex.com/research/articles/rfid_market_forecasts_2009_2019_00001377.asp)
- NYTeknik; 2007-10-24; [www.nyteknik.se/special/automation/article46925.ece](http://www.nyteknik.se/special/automation/article46925.ece)
- Kostallplan; <http://www.jbt.slu.se/KOSTALLPLAN/>; 2009-10-30
- LELY, Brochure LELY QWES-H/HR infra red systems; 2009-11-17;  
[http://www.lely.com/brochures/brochures\\_pdf/dairy/lely-qwes\\_h-en.pdf](http://www.lely.com/brochures/brochures_pdf/dairy/lely-qwes_h-en.pdf)

## 6.3 PERSONAL COMMUNICATIONS

- Andersson Lars. 2009. OLW potato storehouse. December 2009
- Anonymous. 2009. Cowdetect, Agromek exhibition. November 2009
- Arvidsson Johan. 2009. SLU. December 2009
- Ekelöf Joakim. 2009. SLU. October 2009
- Fogelberg Fredrik. 2009. JTI. November 2009
- Karlsson Mats. 2009. Yara. October 2009
- Kjellström Sören. 2009. Stallmästaren. October 2009
- Lindgren Kristina. 2009. JTI. September 2009
- Malm Peter. 2009. HS Kristianstad. October 2009
- Nielsen Per Peetz. 2009. SLU. September 2009
- Nybohm Göran. 2009. Tractechnology. October 2009
- Ohlsson Christina. 2009. DeLaval. October 2009
- Persson Niclas. 2009. Ministry of agriculture. September 2009
- Sundelöf Jenny-Ann. 2009. Ugglarps AB. October 2009
- Svensson Kristher. 2009. Scan. October 2009
-

## APPENDIX A

### Interview protocols

#### 8.1.1 Per Peetz Nielsen, Scientist Animal husbandry

20090923

**Hur positionsbestämmer man djur?**

*-Ofta med GPS halsband, om det inte görs manuellt.*

**Fungerar GPS halsband bra?**

*-Ja utomhus, men om man vill undersöka djur som går in under tak eller så. Behövs någon annan utrustning.*

**Vad får ett alternativt system kosta?**

*-Så billigt som möjligt, men 20-30 000 är rimligt.*

**Vad skulle ett system behöva vara kapabelt till att registrera?**

*-Rörelsemönster, brunst, aktivitet.*

**Vilka användningsområden skulle ett system kunna få?**

*-Utvärdera stall byggnader, genom att se rörelsemönster hos djuren, mäta välbefinnande hos djur. Använda rörelsedata i beteende forskning.*

#### 8.1.2 Niclas Persson, Jordbruksverket

2009-09-17

**1. Det händer att djur tappar sina öronmärken, hur stor andel av kontrollerade djur har bristfällig märkning eller saknar märkning?**

*För 2008 så såg siffrorna ut enligt följande; bland nötkreatur påträffades 1415 djur som saknade märkning av 183143 st. kontrollerade.*

*För får och getter var motsvarande siffra 31916 av 34450. Det går dock inte att säga hur många av dessa som tappat sina brickor och hur många som aldrig varit märkta.*

**2. Finns det något mål att införa elektronisk ID för lantbrukets produktionsdjur?**

*Det finns inga direkta ambitioner i Sverige i den riktningen. För får och getter är det dock tillåtet att använda ett elektroniskt öronmärke i Sverige. För medlemsstater som har fler än 600 000 får och getter är det obligatoriskt från och med årsskiftet att införa elektronisk märkning för djuren. Sverige har dock färre varför det är frivilligt att använda elektronisk identifiering för svenska djurhållare. För nötkreatur saknas fortfarande den nödvändiga EG-lagstiftningen för att införa elektronisk märkning. Diskussioner pågår dock men det återstår att se hur bestämmelserna utformas. Det lutar förmodligen att det blir ett frivilligt införande*

---

*för de medlemsstater som så önskar. Frågan är kontroversiell efter som EID är dyrare än konventionella märken. För länder med små besättningar och dålig lönsamhet så är det svårt att se några direkta vinster med införande av EID.*

**3. Om det gör det, när skulle ett sådant system vara aktuellt för Sverige?**

*Elektroniska öronbrickor tillåtna för får och getter. För nötkreaturen återstår att se var diskussionerna inom EU landar.*

**4. Med RFID taggar på djur öppnas många möjligheter för driftledning, rapportering och spårbarhet. Skulle det vara intressant att länka ett sådant system mot CDB via gårdens driftplanering för direkt rapportering?**

*Ja, den typen av dataöverföring mellan märke och databas är en av att de större vinsterna med EID. Samtidigt är det ett kostsamt system så jag antar att den typen av lösning förutsätter ett obligatoriskt införande.*

**5. Det finns olika typer av taggar, främst en variant som är inbyggd i det befintliga öronmärket, men även en som läggs i idisslarens mage, eller som placeras under huden. Vilken typ skulle vara mest aktuell att använda?**

*För får och getter är det som sagt en bricka med elektronisk identifierare som är godkänt. Minst attraktivt, om man vänder på det, är chip i tanke på att de kan migrera i djuret samt att de är svåra att återfinna då djuret slaktas.*

**6. En rad data kan lagras i en RFID tagg, så som ålder, kön, veterinärbehandlingar etc. Vilka parametrar skulle vara av intresse att lagra i taggen som automatiskt följer djuret till exempelvis slakteriet?**

*Vår tolkning av reglerna är att själva märket endast innehåller djurets identitet. Övriga uppgifter kan lagras i exempelvis foderprogram eller liknande.*

### 8.1.3 Peter Malm, HS Kristianstad

2009-10-02

**1. Hur bestäms bevattningstidpunkt?**

*Oftast är det lantbrukarens förnuft som avgör när det ska bevattnas eller ej. Användning av tensiometer eller dylikt hjälpmedel används sällan. Spade är ett mer frekvent använt hjälpmedel.*

*HS bedömer att det är en allt för liten marknad i Sverige för en prognostjänst för bevattning. Lantmännen har försökt introducera en sådan utan att lyckas.*

## **2. Vanliga typer av bevattningsutrustning?**

*Vattenkanon är det vanligaste på den svenska marknaden, den är mest effektiv i avseende arbete och hektaravverkning. Ramper börjar dock bli allt vanligare, de kräver mer arbete att flytta och sköta men ger en jämnare bevattning och är mer vattneffektiva. Och mindre vindkänsliga*

## **3. Var hämtas bevattningsvattnet?**

*Det vanligaste är att ta ytvatten från närliggande vattendrag, men visst grundvattenuttag förekommer dock. Valet beror mycket på var i landet man befinner sig.*

## **4. Hur stora arealer bevattnas?**

*Ca 100000 ha*

## **5. Vilka grödor ställer högst krav på en precis bevattning?**

*I regel är det viktigare ju dyrare grödan är. T ex. potatis kan tappa så mycket som 500 kg/ dag i utebliven tillväxt utan bevattning.*

## **6. Begränsar vattendomen bevattningsmängden?**

*Det varierar från plats till plats. Det är sällan problem, men i vissa delar av landet har det varit mål uppe i domstol och några vattendrag har helt stängts av för bevattningsuttag. Det är troligt att större krav kommer ställas i framtiden.*

### **8.1.4 Jenny-Ann Sundelöf, Ugglarps AB**

20091001

Frågor slakteri Team Ugglarp AB

#### **1 Sker i dagsläget någon elektronisk identifiering av djur?**

*Nej*

#### **2 Skulle det vara av intresse att införa ett system som automatiskt registrerar när ett djur lastas ombord på slaktbilen?**

*Allt som underlättar arbetet och minskar felkällor är givetvis av intresse!*

#### **3 Ser Ni någon arbetsvinst i att eID märkta djur automatiskt kan registreras?**

*Om samtliga djur vara eID märkta så skulle det säkert vara en arbetsbesparing i stallet. Då skulle det kunna motsvara ungefär en halvtidstjänst för vår del.*

---

---

**4 Sker något arbete hos er att införa ett elektroniskt identifieringssystem för att höja spårbarheten?**

*Nej men vi är i uppstartsfasen med ett projekt tillsammans med Hencol hos några av våra leverantörer som kommer märka djuren med eID.*

**5 Ser Ni eID baserad identifiering som något som i framtiden kan underlätta arbetet med identifiering och rapportering?**

*Se ovan*

8.1.5 Kristher Svensson, Scan, Intransportchef

20091028

**1 Sker i dagsläget någon elektronisk identifiering av djur?**

*Nej*

**2 Skulle det vara av intresse att införa ett system som automatiskt registrerar när ett djur lastas ombord på slaktbilen?**

*Ja, Att slippa den manuella registreringen skulle vara intressant.*

**3 Ser Ni någon arbetsvinst i att eID märkta djur automatiskt kan registreras?**

*Ja, så väl för bonden som lastbilschauffören och i stallet, i dagsläget skriver bonden ner id numren för varje djur på en transportsedel, när djuren och sedlarna kommer till slakteriet kontrolleras numren manuellt mot CDB, det arbete skulle kunna reduceras om det skedde delvis automatiskt.*

**4 Sker något arbete hos er att införa ett elektroniskt identifieringssystem för att höja spårbarheten?**

*Nej, men vi håller på att installera fordonstatorer i lastbilarna för att bli av med bland annat transportsedlarna i pappersform.*

**5 Ser Ni eID baserad identifiering som något som i framtiden kan underlätta arbetet med identifiering och rapportering?**

*Ja om det är ett robust system har det säkert stora fördelar. Både arbetsbesparande och för djuren, genom mindre stress vid identifierings processen.*

8.1.5 Göran Nybom, Tractechonology –Meatrac

20091006

**Fördelar med systemet?**

*Koppling till CDB är under godkännande. Arbetar med UHF teknik vilket ger liten antenn och låg störning samtidigt som den teoretiska räckvidden*

---



är 12 meter den praktiska är dock lägre ca 4-8 meter. Läs noggrannhet nära 100 %. Systemet kan läsa flera djur samtidigt. Tanken med systemet är att höja spårbarheten i distributionsledet från gård till konsument. Inga slakterier har dock gått med i systemet.

#### **Tillämpning djurslag?**

I dagsläget har företaget i Sverige inriktat sig på nötkreatur. Men större grisbesättningar i ryssland har varit intresserade av systemet.

#### **Utbredning?**

I dagsläget används systemet på ett fåtal pilotgårdar. Utvecklingsfasen är i det närmsta klar.

#### **Prisuppgifter?**

Taggar kostar ca 20 kr/st. Läsare och programvara och övrig kringutrustning kostar ca 10000 kr.

#### **Typer av taggar?**

Vanliga örontaggar. Av samma typ som de vanliga EID märkena.

#### **Andra användningsområden inom jordbruket?**

Logistik, Rondering, stöldskydd, ID-access är applikationer som redan används i andra sektorer.

### 8.1.6 Sören Kjellström, Stallmästaren

20091007

#### **Vad kostar en handläsare för EID taggar?**

-Priset på vår handläsare HHR 3000 PRO är c:a 6,000 SEK

#### **Hur stort är läsavståndet?**

- Läs avståndet beror på om man använder sig av HDX eller FDX transponder. När det gäller HDX transponder är läsavståndet c:a 50cm och FDX något kortare.

#### **Hur stor datamängd kan lagras i märkets chip?**

-Datan som lagras i märket är antingen djurets hela identitet eller ett transponder nummer.

#### **Kan data lagras in i chipet kontinuerligt under djurets livstid eller är detta bara möjligt en gång?**

-Datan kan bara läggas in i chipet eller transpondern en gång på grund av att märket följer djuret från födsel till slakt.

#### **För vilka djur är märket godkänt som EID märke?**

---

*På får finns detta märke redan godkänt av Jordbruksverket, och vad det gäller nöt kommer vi att i höst skicka in ett märke för godkännande. På gris används märket som en egen märkning.*

### 8.1.7 Christina Ohlsson, DeLaval

20091022

**-Hur länge har transpondrar använts för att identifiera mjölkboskap?**

*Transpondrar för att identifiera djur har använts i ca 20 år. Aktivitetsmätare i ca 10 år.*

**-Vilken teknik använder delaval för dataöverföringen? t ex IR eller RF?**

*Transpondrarna avläses med magnetiskt fält. Data förs via ALCOM bus till dator.*

**-Är transpondrarna passiva eller aktiva, dvs. har dom batteri eller inte?**

*Transpondrarna har inget batteri endast spole.*

**-Vad kostar en transponder?**

*En transponder kostar ca 500SEK.*

**-Vilka djurtyper används den på?**

*Transponder används på ko, kviga, kalv, buffel.*

**-Hur stor andel av de svenska korna har transpondrar?**

*Av de 350.000 kor vi har i Sverige har gissningsvis 200.000 st transpondrar.*

**-Finns det någon kompatibilitet mot andra system, t ex. att använda EU- godkända RFID, elektroniska öronmärken tillsammans med DeLavals utfodringssystem?**

*Ja, det kan man göra, så länge det är HDX-transpondrar, dvs. att de kan läsas på längre avstånd. FDX kan endast läsas på mkt kort avstånd – några centimeter.*

**-Skulle det finnas några fördelar med att ha ett system i djurstallet som kan lokalisera djurets absoluta position och inte bara som idag veta när djuret passerat en grind eller varit i en kraftfoderstation?**

*Mkt stor fördel i stora besättningar. Där kan det vara svårt att hitta kor som ska behandlas, t ex djur som registrerats för hög aktivitet = brunstiga kor.*

### 8.1.8 Mats Karlsson, Yara

20091028

---

**- Hur identifieras gödselsäckarna under transporten idag?**

*Vårt ansvar för flödet slutar i stort vid våra terminaler, det är Lantmännen och andra distributörer som sköter transporten till slutförbrukaren. Säcken har en rätt tydlig produktmärkning så vi får åtminstone väldigt få reklamationer på grund av fellastning, kanske 1 per år på ett flöde på 500 000 ton.*

**- Används RFID taggar på några produkter?**

*Vi har idag ingen användning av RFID teknik och vi använder inte heller streckkod på Lantbruksprodukter.*

**- Om RFID inte används finns då någon ambition att införa detta?**

*Vi har diskuterat att använda RFID märkning för att säkerställa att vi lastar rätt produkt och även för att inventera lagret. Tekniken har dock hittills varit för dyr jämfört de vinster vi sett. Vi har heller inte sett någon rationell anordning för att applicera etiketten på våra storsäckar som utgör 95-97% av flödet. Det är svårt att få klister att fästa på säckens väv. Skulle vi se stora fördelar med tekniken så löses dock säkert det problemet.*

**8.1.9 Joakim Ekelöf, SLU**

20091013

**på vilket djup får man den bästa avläsningen?**

*Det beror på flera faktorer så som rotdjup, gröda, bevattningssystem, jordart etc och variationer inom fält. Gällande potatis och sandjordar så tycker jag att 20 cm är ett intressant djup att installera sensorerna på. Det bästa är om man kan täcka in flera djup. Har man två bör en sitta på 40 cm.*

**Hur tätt man bör placera sensorerna?**

*Ju fler sensorer desto bättre, men det beror helt på fältförhållandena.*

**8.1.10 Lars Andersson, OLW**

20091201

**Hur hanteras den skördade potatisen?**

*Det mesta skördas i lösvikt, men en del i lådor. Vid utlastning från OLWs lager transporteras allt i lösvikt.*

**Hur identifieras skörden?**

*Vid lösvikt mäts vikten på inlastade partier från respektive leverantör, vid utlastning vägs återigen partiet och man räknar baklänges för att veta från vilken leverantör potatisen kommer. Vid lådlagring lagras varje leverantör i egen rad vilket gör att man vet att lådan från en rad kopplas till just den leverantören*

**Finns problem med lagrings förluster pga. Dålig kvalitet?**

---

*Nej, inga större lagringsförluster. Det sker stickprovs kontroller i partierna vid intransport. Före skörd kontrolleras fälten och om misstanke finns för kvalitets problem levereras potatisen direkt till fabrik.*

**Varierar kvalitén beroende på var den är skördad inom ett fält?**

*Ja, men det utjämnas i lagret pga. De stora kvantiteter som hanteras (500-700 ton/vecka). Dock om ett parti befaras ha dåliga lagringsegenskaper går det ut ur lagret vid ett tidigt stadium. Då all potatis skalas är skurv ett mindre problem, vid röta kasseras dock potatisen. Det kan säkert vara ett problem för mindre leverantörer som hanterar små mängder av främst konsumtionspotatis.*

8.1.11 Johan Arvidsson, SLU

20091123

**Skulle det finnas något behov att avläsa parametrar i fält automatiskt?**

*-Ja, i forsknings syfte kan det vara av intresse att kunna ta in data utan att behöva gå ut i fält för att effektivisera och få en billigare provtagning. Dessutom kan det vara av värde att kunna mäta data med tidsupplösning i t ex. utlakningsförsök.*

**Vilka parametrar skulle vara intressanta att kunna mäta?**

*-Syre, och koldioxid. Men även andra gaser som metan och lustgas skulle vara intressant om det finns utrustning som kan mäta detta i fält. Även näringsämnen kan vara av intresse att mäta i realtid för precisions åtgärder.*

---

## APPENDIX B

SLUs										
<b>Områdeskalkyler 2009</b>		<b>Slaktkyckling</b>						Gns området		
Version 09-2b; Utgivningsdatum 2009-01-23										
Besättningsstorlek:	80	000								
slaktkycklingar										
Levande vikt vid slakt 1,725 kg										
Nybyggnad, 4000 m <sup>2</sup> golvyta. Inköpt foder										
<b>Med RTLS</b>										
		Omgångar per år: 7,0				Omgångar per år: 7,0				
		Dödlighet: 4,0%				Dödlighet: 4,0%				
		Foderförbrukning, kg/kg: 1,70				Foderförbrukning, kg/kg: 1,70				
Intäkter och särkostnader per kvadratmeter och omgång			Kassation vid slakt: 1,5%				Kassation vid slakt: 1,5%			
		Max beläggning, kg/m <sup>2</sup> : 36				Max beläggning, kg/m <sup>2</sup> : 36				
		Kvant	pris	kr		Kvant	pris	kr		
<b>INTÄKTER</b>										
3323	Slaktkyckling	kg	35,46	7,96	282	kg	35,46	7,96	282	
93601	Stallgödsel, kväve (N)	kg	0,14	15,54	2	kg	0,14	15,54	2	
93602	Stallgödsel, fosfor (P)	kg	0,16	41,03	7	kg	0,16	41,03	7	
93603	Stallgödsel, kalium (K)	kg	0,30	12,75	4	kg	0,30	12,75	4	
SUMMA INTÄKTER					295					
<b>SÄRKOSTNADER</b>										
4316	Daggammal kyckling	st	21,74	3,50	76	st	21,74	3,50	76	
4336	Slaktkycklingfoder Fodersäd,	kg	40,39	3,09	125	kg	40,39	3,09	125	
94336	egenproducerat	kg	20,81	1,23	26	kg	20,81	1,23	26	
5310	El	kWh	5,0	0,65	3	kWh	5,0	0,65	3	
5330	Eldningsolja	l	1,40	7,12	10	l	1,40	7,12	10	
4360	Utlastning	st	20,90	0,28	6	st	20,90	0,28	6	
4370	Diverse kostnader	kr	1	11,10	11	kr	1	11,10	11	
	EID- märke		21	20,00	420					
SUMMA SÄRKOSTNADER 1					677					
0000	Byggnader, underhåll	kr	300	1,3%	4	kr	300	1,3%	4	
10000	Ränta rörelsekapital	kr	0	7%	0	kr	0	7%	0	
SUMMA SÄRKOSTNADER 2					681					
0000	Byggnader, avskr + ränta	kr	300	7,2%	22	kr	300	7,2%	22	
20000	Arbete	tim	0,06	188,00	11	tim	0,06	188,00	11	
SUMMA SÄRKOSTNADER 3					714			-1,43	294	
<b>TÄCKNINGSBIDRAG</b>										
30000	TB 1 = INTÄKTER - SÄRKOSTNADER				1				38	
	TB 2 = INTÄKTER - SÄRKOSTNADER				2				34	
	TB 3 = INTÄKTER - SÄRKOSTNADER				3				1	
relativ diff. %		Units								
<b>142,86%</b>		<b>53</b>								

**SLUs Områdeskalkyler 2009**
**Slaktsvin**

Gns området

Version 09-2b; Utgivningsdatum 2009-01-23

Egen fodertillverkning

Levande vikt vid slakt: 115 kg. Slaktutbyte  
74.6%.Ange  
stödområde
  

Ange antal stödenheter

Nybyggnad, långsgående långtråg, blötutfodring

Ange produktionsstorlek

Med RTLS

Intäkter och särkostnader per producerat djur		Omgångar per år: 3,25 MJ/kg tillväxt: 34,90						Kvant	pris	kr
		Kvant	pris	kr	Kvant	pris	kr			
<b>INTÄKTER</b>										
3221	Kött	kg	85,8	14,68	1 260	kg	85,8	14,68	1 260	
3225	Leveransavtal	st	85,8	0,00	0	st	85,8	0,00	0	
3280	Nationellt stöd	kr	0,0	0	0	kr	0,0	0	0	
SUMMA INTÄKTER				1 260			1 260			
<b>SÄRKOSTNADER</b>										
4220	Smågris	st	1,0	533,00	533	st	1,0	533,00	533	
4220	Förmedlingsavgift, frakt, tillägg	st	1	61,00	61	st	1	61,00	61	
4240	Slaktsvinsfoder	kg	0	2,41	0	kg	0	2,41	0	
4233	Fodersäd, inköpt	kg	0	1,45	0	kg	0	1,45	0	
94240	Fodersäd, egenproducerat	kg	200	1,22	244	kg	200	1,22	244	
4241	Slaktsvinskoncentrat	kg	45	4,26	192	kg	45	4,26	192	
4272	Djurhälsovård	kr	1	4,00	4	kr	1	4,00	4	
4270	Dödlighet och kass. vid slakt (1.7%)	kr	693	1,7%	12	kr	693	1,7%	12	
4270	Diverse kostnader	kr	1	36,00	36	kr	1	36,00	36	
	EID märke		1	20,00	20					
SUMMA SÄRKOSTNADER 1				1 102			1 082			
0000	Byggnader, underhåll	kr	1 660	0,75%	12	kr	1 660	0,75%	12	
0000	Ränta djurkapital	kr	183	7%	13	kr	183	7%	13	
10000	Ränta rörelsekapital	kr	0	7%	0	kr	0	7%	0	
SUMMA SÄRKOSTNADER 2				1 127			1 107			
0000	Byggnader, avskr + ränta	kr	1 660	8,3%	138	kr	1 660	8,3%	138	
20000	Arbete	tim	0,30	188,00	56	tim	0,30	188,00	56	
SUMMA SÄRKOSTNADER 3				1 321			1 301			
<b>TÄCKNINGSBIDRAG</b>										
TB 1 = INTÄKTER - SÄRKOSTNADER					SUMMA SÄRKOSTNADER 3					
30000	1				158		20,00		178	
	2				133		20,00		153	
	3				-61		20,00		-41	
relativ diff. %		Units								
1,54%		1								



SLUs		Mjölko, 9 000 kg		-		Gns området			
<b>Områdeskalkyler 2009</b>		Version 09-2b; Utgivningsdatum 2009-01-23							
SLB/SRB-kor, 600 kg levande vikt, 110 dagars betesperiod,		Ange stödområde		Ej stödområde		▼			
Nybyggnad; varm lösdrift, flytgödselhantering,		Ange antal stödenheter		91-		▼			
Hö näringsinnehåll 10,2 MJ/kg ts,		Ange eurokurs		90 kor		▼			
Ensilage, näringsinnehåll: 10.6 MJ,		Ange produktionsstorlek							
				Med RTLS		Utan RTLS			
		Avkastning, kg ECM		9 000					
		Andel mejerimjolk		92,5%					
Intäkter och särkostnader per ko och år (2,4)		Överutfodring/spill grovf.		6,0%					
		Överutfodring/spill kraff.		6,0%					
		Kvant		Pris		kr			
		Kvant		Pris		kr			
<b>INTÄKTER</b>									
3110	Levererad mjölk	kg	8 325	3,61	30 053	kg	8 325	3,61	30 053
93121	Livkalv, kviga	st	0,5	975	488	st	0,5	975	488
3121	Livkalv, tjur	st	0,5	1 350	675	st	0,5	1 350	675
3133	Kött, utslagsko	kg	116	21,98	2 550	kg	116	21,98	2 550
3080	Nationellt stöd	kg	8 325	0,00	0	kg	8 325	0,00	0
<b>SUMMA INTÄKTER</b>				<b>33 766</b>		<b>33 766</b>			
<b>SÄRKOSTNADER</b>									
94113	Kalvfärdig kviga	st	0,4	10 600	4 240	st	0,4	10 600	4 240
4134	Mjölknäring (kalvnäring)	kg	21	18,19	382	kg	21	18,19	382
4151	Hö, inköpt	kg ts	0	0,00	0	kg ts	0	0,00	0
94151	Hö, egenproducerat	kg ts	442	1,93	853	kg ts	442	1,93	853
4155	Ensilage, inköpt	kg ts	0	0,00	0	kg ts	0	0,00	0
94155	Ensilage, egenproducerat	kg ts	1 957	1,70	3 327	kg ts	1 957	1,70	3 327
94154	Bete	kg ts	880	0,85	748	kg ts	880	0,85	748
4153	HP-massa	kg	0	1,95	0	kg	0	1,95	0
4135	Betfor	kg	336	3,30	1 109	kg	336	3,30	1 109
4133	Fodersäd, inköpt	kg	1 736	1,40	2 430	kg	1 736	1,40	2 430
94133	Fodersäd, egenproducerat	kg	0	1,11	0	kg	0	1,11	0
4132	Högmjölkkoncentrat	kg	1 376	3,00	4 128	kg	1 376	3,00	4 128
94152	Foderhalm	kg ts	0	0,50	0	kg ts	0	0,50	0
4138	Mineralfoder	kg	40	8,76	350	kg	40	8,76	350
4157	Strömedel	kg	255	0,50	128	kg	255	0,50	128
4170	Semin- och kontrollavgift	kr	1	761	761	kr	1	761	761
4173	Veterinär, medicin	kr	1	737	737	kr	1	737	737
4174	Rådgivning	kr	1	72	72	kr	1	72	72
5310	EI	kWh	710	0,65	462	kWh	710	0,65	462
6312	Djurförsäkring	kr	1	125	125	kr	1	125	125
4180	Diverse kostnader	kr	1	839	839	kr	1	839	839
EID märke			20	0,45	9,0				
<b>SUMMA SÄRKOSTNADER 1</b>				<b>20 700</b>		<b>20 691</b>			
0000	Byggnader, underhåll	kr	86 200	1,8%	1 552	kr	86 200	1,8%	1 552
0000	Utfodringssystem, underhåll	kr	6 300	2,0%	126	kr	6 300	2,0%	126
0000	Foderberedningsanl. underhåll	ton	1,74	34,00	59	ton	1,74	34,00	59
0000	Ränta djurkapital	kr	8 487	7%	594	kr	8 487	7%	594

10000	Ränta rörelsekapital	kr	0	7%	0	kr	0	7%	0
	<b>SUMMA SÄRKOSTNADER 2</b>				23 031				23 022
0000	Byggnader, avskr + ränta	kr	86 200	8,0%	6 896	kr	86 200	8,0%	6 896
0000	Utfodringssystem., avskr + ränta	kr	6 300	13,5%	851	kr	6 300	13,5%	851
0000	Foderberedningsanl., avskr + ränta	ton	1,74	130,00	226	ton	1,74	130,00	226
20000	Arbete	tim	38	188,00	7 144	tim	38	188,00	7 144
	<b>SUMMA SÄRKOSTNADER 3</b>				38 148				38 139
	<b>TÄCKNINGSBIDRAG</b>								<b>SUMMA SÄRKOSTNADER 3</b>
30000	TB 1 = INTÄKTER - SÄRKOSTNADER 1				13 066				13 075
	TB 2 = INTÄKTER - SÄRKOSTNADER 2				10 735				10 744
	TB 3 = INTÄKTER - SÄRKOSTNADER 3				-4 382				-4 373
	relativ diff. %								
	<b>0,02%</b>								
					Units				
					<b>2</b>				





## SLUs

## Områdeskalkyler 2009

## Vår- sommarlamm (finull x dorset) x texel

Gns -området

Version 09-2c; Utgivningsdatum 2009-03-26

Näringsinnehåll i grovfoder, per kg ts: 10,0 MJ,

Inköpt rekrytering. Lamning december - april.

160 dagars betesperiod, Nybyggnad, ströbädd,

Medelvikt per tacka 75 kg, slaktutbyte 40%,

200 tackor ▼

Ange produktionsstorlek

				Med RTLS			Utan RTLS		
				Antal lamm: 2,0					
				Slaktvikt, kg per lamm: 19,5					
Intäkter och särkostnader per tacka och år				Rekryteringsprocent 22%					
		Kvant	pris	kr	Kvant	pris	kr		
<b>INTÄKTER</b>									
3312	Slaktlamm	kg	39,0	42,39	1 653	kg	39,0	42,39	1 653
3313	Kött, utslagsfår	kg	6,6	19,34	128	kg	6,6	19,34	128
3314	Pälslammskinn	st	0,0	155,00	0	st	0,0	155,00	0
3314	Ull	kg	2,0	10,00	20	kg	2,0	10,00	20
3311	Livdjur	st	0,0	1 000,00	0	st	0,0	1 000,00	0
SUMMA INTÄKTER					1 801				1 801
<b>SÄRKOSTNADER</b>									
4311	Livdjur	st	0,22	800,00	176	st	0,22	800,00	176
4155	Ensilage, inköpt	kg ts	0,0	0,00	0	kg ts	0,0	0,00	0
94155	Ensilage, egenproducerat	kg ts	290	1,67	484	kg ts	290	1,67	484
94154	Bete	kg ts	260	0,00	0	kg ts	260	0,00	0
4331	Kraftfoder	kg	170	2,61	444	kg	170	2,61	444
4331	Fodersäd, inköpt	kg	0	1,40	0	kg	0	1,40	0
94133	Fodersäd, egenproducerat	kg	0	0,00	0	kg	0	0,00	0
4331	Koncentrat	kg	0	2,87	0	kg	0	2,87	0
4138	Mineralfoder	kg	0	8,76	0	kg	0	8,76	0
4157	Strömedel	kg	130	0,50	65	kg	130	0,50	65
4371	Bagghållning	kr	1	53,00	53	kr	1	53,00	53
4370	Diverse kostnader	kr	1	152,00	152	kr	1	152,00	152
	Öronmärke		2	20,00	40				
SUMMA SÄRKOSTNADER 1					1 414				1 374
0000	Byggnader, underhåll	kr	5 900	1,5%	89	kr	5 900	1,5%	89
0000	Ränta djurkapital	kr	691	7%	48	kr	691	7%	48
10000	Ränta rörelsekapital	kr	0	7%	0	kr	0	7%	0
SUMMA SÄRKOSTNADER 2					1 551				1 511
0000	Byggnader, avskr + ränta	kr	5 900	8,5%	502	kr	5 900	8,5%	502
20000	Arbete	tim	3,8	188,00	714	tim	3,8	188,00	714
SUMMA SÄRKOSTNADER 3					2 767				2 727
<b>TÄCKNINGSBIDRAG</b>									
30000	TB 1 = INTÄKTER - SÄRKOSTNADER 1				387				427
	TB 2 = INTÄKTER - SÄRKOSTNADER 2				250				290
	TB 3 = INTÄKTER - SÄRKOSTNADER 3				-966				-926
relativ diff. %		Units							
1,47%		1							



SLUs

Områdeskalkyler 2009

Matpotatis, höstleverans

Gns området

Version 09-2b; Utgivningsdatum 2009-01-23

Omfattning: 10 ha, leverans på hösten, Hantering i storlådor,

Ange stödområde



Enradig samlingsupptagare med rulltank.

Ange antal stödenheter

Sort; Bintje eller motsvarande.

Ange P-AI klass



Ange K-AI klass

		Med RTLS			Utan RTLS				
Intäkter och särkostnader per hektar		Avkastning, dt/ha: 305							
		Kvant	Pris	kr	Kvant	Pris	kr		
<b>INTÄKTER</b>									
3052	Matpotatis, avsalu (80 %)	dt	238	180,00	42 840	dt	238	180,00	42 840
3052	Stora (10 %)	dt	30	180,00	5 400	dt	30	180,00	5 400
3054	Frånrens (10 %)	dt	30	0	0	dt	30	0	0
4090	Lagringsförlust (2.5%)	dt	8	0	0	dt	8	0	0
3080	Nationellt stöd	kr	0	0	0	kr	0	0	0
3080	Kompensationsbidrag, potatis	kr	0	0	0	kr	0	0	0
3081	Miljöstöd, fånggröda	kr	0	800	0	kr	0	800	0
3081	Miljöstöd, vårbearbetning	kr	0	300	0	kr	0	300	0
3081	Miljöstöd, både fånggröda och vårbearbet.	kr	0	200	0	kr	0	200	0
SUMMA INTÄKTER					48 240			48 240	
<b>SÄRKOSTNADER</b>									
94010	Utsäde (eget)	dt	14,7	193,00	2 837	dt	14,7	193,00	2 837
4010	Utsäde, matpotatis	dt	7,3	640,15	4 673	dt	7,3	640,15	4 673
4021	Gödsling kväve (NS27-4)	kg	92	15,54	1 430	kg	92	15,54	1 430
4024	Gödsling fosfor (P)	kg	35	41,03	1 436	kg	35	41,03	1 436
4025	Gödsling kalium (KSMg)	kg	162	20,34	3 295	kg	162	20,34	3 295
5360	Drivmedel, traktor	tim	26	125,00	3 250	tim	26	125,00	3 250
4041	Bekämp. medel, ogräs	ggr	1,0	290,00	290	ggr	1,0	290,00	290
4045	Bladmögelbekämpning	ggr	6,0	210,00	1 260	ggr	6,0	210,00	1 260
4040	Blastdödning	ggr	2,0	756,00	1 512	ggr	2,0	756,00	1 512
5314	EI, bevattning	kWh	700	0,65	455	kWh	700	0,65	455
4070	Odlaravgift	kr	1,0	315,00	315	kr	1,0	315,00	315
	Prognosinstr. Batteri		0,500	119,00	60	kr			0
SUMMA SÄRKOSTNADER 1					20 813			20 753	
0000	Traktor, underhåll	tim	26,0	29,00	754	tim	26,0	29,00	754
0000	Spruta, underhåll	tim	0,0	252,00	0	tim	0,0	252,00	0
0000	Potatissättare, underhåll	tim	1,1	330,00	363	tim	1,1	330,00	363
0000	Potatiskupare, underhåll	tim	2,4	105,00	252	tim	2,4	105,00	252
0000	Potatisupptagare, underhåll	tim	7,5	279,00	2 093	tim	7,5	279,00	2 093
0000	Bevattning, underhåll	ggr	3,0	180,00	540	ggr	3,0	180,00	540
0000	Lådor, underhåll	ton	30,5	6,90	210	ton	30,5	6,90	210
0000	Sorteringsanl. underhåll	ton	30,5	81,00	2 471	ton	30,5	81,00	2 471
10000	Ränta rörelsekapital	kr	0	7%	0	kr	0	7%	0
SUMMA SÄRKOSTNADER 2					27 496			27 436	
0000	Potatissättare, avskr + ränta	tim	1,1	487	536	tim	1,1	487	536

0000	Spruta, avskr+ränta	tim	0,0	330	0	tim	0,0	330	0
0000	Potatiskupare, avskr + ränta	tim	2,4	184,00	442	tim	2,4	184,00	442
0000	Potatisupptagare, avskr + ränta	tim	7,5	563,00	4 223	tim	7,5	563,00	4 223
0000	Bevattning, avskr+ränta	kr	3,0	1 042,00	3 126	kr	3,0	1 042,00	3 126
0000	Lådor, avskr + ränta	ton	30,5	85,00	2 593	ton	30,5	85,00	2 593
0000	Sorteringsanlägg. och truck, avskr+ränta	ton	30,5	166,00	5 063	ton	30,5	166,00	5 063
	Prognosinstr. mjukv. + 20 noder 40 ha	kr	1,000	95,70	96				0
20000	Arbete	tim	90	182	16 380	tim	90	182	16 380
SUMMA SÄRKOSTNADER 3					59 955	59 799			
<b>TÄCKNINGSBIDRAG</b>					<b>SUMMA SÄRKOSTNADER 3</b>				
30000	TB 1 = INTÄKTER - SÄRKOSTNADER 1		0,22	60,00	27 427				27 487
	TB 2 = INTÄKTER - SÄRKOSTNADER 2		0,29	60,00	20 744				20 804
	TB 3 = INTÄKTER - SÄRKOSTNADER 3		-1,35	156,00	-11 715				-11 559
relativ diff. %			Units						
<b>0,26%</b>			<b>87</b>						



SLUs

**Områdeskalkyler 2010**      **Ensilage, 3 skördar**  
Version 10-01; Utgivningsdatum 2009-11-02

Gns området

Omfattning: 40-60 ha vall + grönfoder, tre ensilageskördar, plansilo,  
Gräsvall. Näringsinnehåll per kg ts: 11 MJ, 136 gram råprot,  
Hanteringskedja: Hackvagn,

Aktuella priser  
stödombud 91-  
Antal hektar  
(kompensationsbidrag)

inläggning i silo med lastmaskin, 3 man under skörd,

Ange P-AI klass  
Ange K-AI klass

		Med RTLS			Utan RTLS			
		Fältavkastning,						
		kg ts: 6 600						
		ts-halt: 35%						
Intäkter och särkostnader		Fältförluster: 6%						
per hektar		Lagr.- och kons.förl: 20%						
		Kvant	Pris	kr	Kvant	Pris	kr	
<b>INTÄKTER</b>								
3062	Ensilage, avsalu (efter förluster)	kg ts	0	0,00	0	0,00	0	
93062	Ensilage, egen förbrukning	kg ts	4 900	2,11	10 339	4 900	2,11	10 339
3081	Miljöstöd, öppet odl.land.	kr	0	0	0	0	0	
3081	Miljöstöd, flerårig vallodling	kr	0	300	0	300	0	
3081	Miljöstöd, vallodling, grund	kr	1	300	300	1	300	
3081	Miljöstöd, vallodling, tillägg	kr	0	0	0	0	0	
3068	Kompensationsbidrag, vall och bete	kr	0	0	0	0	0	
SUMMA INTÄKTER				10 639		10 639		
<b>SÄRKOSTNADER</b>								
4010	Utsäde, slättervall	kg	7,0	41,09	288	7,0	41,09	288
4021	Gödsling kväve (NS27-4)	kg	0	9,06	0	0	9,06	0
4024	Gödsling fosfor (P)	kg	0	11,96	0	0	11,96	0
4025	Gödsling kalium (K)	kg	0	16,95	0	0	16,95	0
94021	Stallgödsel kväve (N)	kg	183	9,06	1 658	183	9,06	1 658
94024	Stallgödsel fosfor (P)	kg	10	11,96	120	10	11,96	120
94025	Stallgödsel kalium (K)	kg	43	16,95	729	43	16,95	729
94026	Stallgödsel, övrigt	kg	0,0	0,00	0	0,0	0,00	0
5360	Drivmedel, traktor	tim	4,8	110,00	528	4,8	110,00	528
5360	Drivmedel, lastmaskin	tim	0,5	128,00	64	0,5	128,00	64
4082	Myrsyra	l	80	14,85	1 188	80	14,85	1 188
	Prognosinstr. Batteri		0,500	119,00	59,5			0
SUMMA SÄRKOSTNADER 1				4 635		4 575		
0000	Traktor, underhåll	tim	4,8	31,00	149	4,8	31,00	149
0000	Slätterkross, underhåll	tim	2,1	180,00	378	2,1	180,00	378
0000	Hackvagn, underhåll	tim	1,6	273,00	437	1,6	273,00	437
0000	Lastmaskin, underhåll	tim	0,5	73,00	37	0,5	73,00	37
0000	Plansilo, underhåll	kr	816	0,5%	94	18 816	0,5%	94
10000	Ränta rörelsekapital	kr	0	7%	0	0	7%	0

SUMMA SÄRKOSTNADER 2				5 730		5 670		
0000	Slätterkross, avskr + ränta	tim	2,1	324,00	680	2,1	324,00	680
0000	Hackvagn, avskr + ränta	tim	1,6	878,00	1 405	1,6	878,00	1 405
0000	Lastmaskin, avskr + ränta	tim	0,5	110,00	55	0,5	110,00	55
0000	Plansilo, avskr + ränta	kr	816	8,3%	1 562	18 816	8,3%	1 562
	Prognosinstr. mjukv. + 20 noder 40 ha	kr	1,000	95,70	96			0
20000	Arbete	tim	6,3	187,00	1 178	6,3	187,00	1 178
SUMMA SÄRKOSTNADER 3				10 706		10 550		
0000	Alt.värde mark	kr			0			0
SUMMA SÄRKOSTNADER 4				10 706		10 550		
<b>TÄCKNINGSBIDRAG</b>								
30000	TB 1 = INTÄKTER - SÄRKOSTNADER 1				6 004			6 064
	TB 2 = INTÄKTER - SÄRKOSTNADER 2				4 909			4 969
	TB 3 = INTÄKTER - SÄRKOSTNADER 3				-67			89
	TB 4 = INTÄKTER - SÄRKOSTNADER 4				-67			89
	relativ diff. %		Units					
	<b>1,48%</b>		<b>74</b>					

SLUs



Områdeskalkyler 2010

Höstvete (foder)

Gns området

Version 10-01; Utgivningsdatum 2009-11-02

Vattenhalt 14 %,

Ange antal stödenheter	91-	▼
Ange produktionsstorlek	70 ha	▼
Ange P-AI klass	III	▼
Ange K-AI klass	IV	▼

Intäkter och särkostnader per hektar	Med RTLS Avkastning, kg/ha 5 800			Utan RTLS Avkastning, kg/ha 5 800			
	Kvant	Pris	kr	Kvant	Pris	kr	
<b>INTÄKTER</b>							
3011 Vete, fodersäd, avsalu	kg	5 800	0,99	5 742	5 800	0,99	5 742
93011 Fodervete, hemmaförbrukning	kg	0	0,00	0	0	0,00	0
3080 Komp. bidrag, spannmål	kr	0	0	0	0	0	0
3081 Miljöstöd, fånggröda	kr	0	800	0	0	800	0
SUMMA INTÄKTER			5 742		5 742		
<b>SÄRKOSTNADER</b>							
4010 Utsäde, höstvete, foder	kg	190	3,65	694	190	3,65	694
4021 Gödsling kväve (NS27-4)	kg	136	9,06	1 232	136	9,06	1 232
4024 Gödsling fosfor (P)	kg	14	11,96	167	14	11,96	167
4025 Gödsling kalium (K)	kg	9	16,95	153	9	16,95	153
5360 Drivmedel, traktor	tim	4,4	110,00	484	4,4	110,00	484
5360 Drivmedel, tröska	tim	0,2	265,00	53	0,2	265,00	53
4041 Bekämp. medel, ogräs	ggr	1,0	284,00	284	1,0	284,00	284
4041 Bekämp. medel, brodd	ggr	0,2	319,00	64	0,2	319,00	64
4042 Bekämp. medel, svamp	ggr	0,8	290,00	232	0,8	290,00	232
4043 Bek. medel, stråknäckare	ggr	0,1	319,00	32	0,1	319,00	32
4043 Bek. medel, insekt., axgång	ggr	0,5	78,00	39	0,5	78,00	39
4065 Sprutning, lejd	ggr	0,0	152,00	0	0,0	152,00	0
4065 Tröskning, lejd	tim	0,0	1 953,00	0	0,0	1 953,00	0
5700 Transport	dt	62	4,90	304	62	4,90	304
4071 Torkning (vh 20%)	dt	62	11,90	738	62	11,90	738
4075 Analys, fodersäd	st	0,17	95,00	16	0,17	95,00	16
Prognosinstr. Batteri		0,500	119,00	59,5			
SUMMA SÄRKOSTNADER 1			4 552		4 492		
0000 Traktor, underhåll	tim	4,4	31,00	136	4,4	31,00	136
0000 Tröska, underhåll	tim	0,2	500,00	100	0,2	500,00	100
0000 Spruta, underhåll	tim	0,2	270,00	54	0,2	270,00	54
10000 Ränta rörelsekapital	kr	0	7%	0	0	7%	0
SUMMA SÄRKOSTNADER 2			4 842		4 782		
0000 Tröska, avskr+ränta	tim	0,2	1 044,00	209	0,2	1 044,00	209
0000 Spruta, avskr+ränta	tim	0,2	354,00	71	0,2	354,00	71
20000 Arbete	tim	4,7	187,00	879	4,7	187,00	879
Prognosinstr. mjukv. + 20 noder 40 ha	kr	1,000	95,70	96			
SUMMA SÄRKOSTNADER 3			6 097		5 941		
<b>TÄCKNINGSBIDRAG</b>							
30000 TB 1 = INTÄKTER - SÄRKOSTNADER 1				1 190			1 250
TB 2 = INTÄKTER - SÄRKOSTNADER 2				900			960
TB 3 = INTÄKTER - SÄRKOSTNADER 3				-355			-199

relativ diff. %

Units

2,63%

158



## SLUs

## Områdeskalkyler 2010

## Vårkorn

Gns området

Version 10-01; Utgivningsdatum 2009-11-02

Vattenhalt 14 %,

Aktuella priser ▼

Ej stödområde ▼

Ange stöd 91- ▼

Al stöd 70 ha ▼

produktio III ▼

Ange P IV ▼

Ange K-AI klass

	Med RTLS				Utan RTLS			
	Intäkter och särkostnader per hektar	Avkastning, kg/ha 4 600			Avkastning, kg/ha 4 600			
		Kvant	Pris	kr	Kvant	Pris	kr	
<b>INTÄKTER</b>								
3015	Korn, avsalu	kg	4 600	0,80	3 680	4 600	0,80	3 680
93015	Korn, hemmaförbrukning	kg	0	0,00	0	0	0,00	0
3080	Komp. bidrag, spannmål	kr	0	0	0	0	0	0
3081	Miljöstöd, fånggröda	kr	0	800	0	0	800	0
3081	Miljöstöd, värbearbetning	kr	0	300	0	0	300	0
3081	Miljöstöd, både fånggröda och värbearbet.	kr	0	200	0	0	200	0
SUMMA INTÄKTER				3 680		3 680		
<b>SÄRKOSTNADER</b>								
4010	Utsäde, vårkorn	kg	180	4,53	815	180	4,53	815
4021	Gödsling kväve (NS27-4)	kg	87	9,06	788	87	9,06	788
4024	Gödsling fosfor (P)	kg	14	11,96	167	14	11,96	167
4025	Gödsling kalium (K)	kg	3	16,95	51	3	16,95	51
5360	Drivmedel, traktor	tim	4,4	110,00	484	4,4	110,00	484
5360	Drivmedel, tröska	tim	0,2	265,00	53	0,2	265,00	53
4041	Bekämp. medel, ogräs	ggr	1,0	113,00	113	1,0	113,00	113
4042	Bekämp. medel, svamp	ggr	0,2	228,00	46	0,2	228,00	46
4043	Bekämp. medel, bladlöss	ggr	0,2	142,00	28	0,2	142,00	28
4065	Sprutning, lejd	ggr	0,0	152,00	0	0,0	152,00	0
4065	Tröskning, lejd	tim	0,0	1 953,00	0	0,0	1 953,00	0
5700	Transport	dt	49	4,90	240	49	4,90	240
4071	Torkning (vh 20%)	dt	49	11,90	583	49	11,90	583
4075	Analys, fodersäd	st	0,14	95,00	13	0,14	95,00	13
	Prognosinstr. Batteri		0,500	119,00	59,5			
SUMMA SÄRKOSTNADER 1				3 441		3 381		
0000	Traktor, underhåll	tim	4,4	31,00	136	4,4	31,00	136
0000	Tröska, underhåll	tim	0,2	500,00	100	0,2	500,00	100
0000	Spruta, underhåll	tim	0,2	270,00	54	0,2	270,00	54
10000	Ränta rörelsekapital	kr	0	7%	0	0	7%	0
SUMMA SÄRKOSTNADER 2				3 731		3 671		
0000	Tröska, avskr+ränta	tim	0,2	1 044,00	209	0,2	1 044,00	209

---

0000	Spruta, avskr+ränta	tim	0,2	354,00	71	0,2	354,00	71
	Prognosinstr. mjukv. + 20 noder							
	40 ha	kr	1,000	95,70	96			
20000	Arbete	tim	4,8	187,00	898	4,8	187,00	898
SUMMA SÄRKOSTNADER 3					5 005			4 849
<b>TÄCKNINGSBIDRAG</b>								
30000	TB 1 = INTÄKTER - SÄRKOSTNADER 1				239			299
	TB 2 = INTÄKTER - SÄRKOSTNADER 2				-51			9
	TB 3 = INTÄKTER - SÄRKOSTNADER 3				-1 325			-1 169
relativ diff. %		Units						
3,22%		195						

---





---

Examensarbete (Institutionen för energi och teknik)  
*Master Thesis (Department of Energy and Technology)*  
**ISSN 1654-9392**  
2010:02  
Uppsala 2010

---