

Mechanical Assemblies Design of Underwater Electric Motor

Normariah Che Maideen¹, Indra Putra Almanar², Amir Yazid Ali³, Dahaman Ishak⁴, Mohd Rizal Arshad⁵

^{1,2,3,4}Industrial Assemblies Research Group, School of Mechanical Engineering
Universiti Sains Malaysia, Engineering Campus

14300 Nibong Tebal, Seberang Perai Selatan, Pulau Pinang, Malaysia

Tel: +604-5999999 ext. 6318, Fax: +604-5941025, E-mail: normariahmaideen@gmail.com, meinput@eng.usm.my, meamir@eng.usm.my

⁵USM Electric Power Research Group & ⁶USM Robotics Research Group, School of Electrical and Electronic Engineering
Universiti Sains Malaysia, Engineering Campus

14300 Nibong Tebal, Seberang Perai Selatan, Pulau Pinang, Malaysia

Tel: +604-599599 ext. 6074, Fax: +604-5941023, E-mail: dahaman@eng.usm.my, rizal@eng.usm.my

Abstract

Electric motor plays an important role in providing Autonomous Underwater Vehicle (AUV) system the capability for motion. Therefore, the motor should be designed as an integral part of an AUV which provide an efficient way for the mobility and maneuverability of the AUV. At the same time, the motor should not become a liability part that consume unnecessary portion of the limited energy available within the AUV system.

This paper is presented to demonstrate the steps taken in design stages of underwater electric motor where all of the aforementioned matters are taken into consideration. The first step is to convert the task requirements into technical requirements, followed by Functional Analysis System Technique (FAST) which was employed to make sure that there will be no important functions are neglected. Decision matrix is then used to reveal the most suitable configuration of water tight assembly system. The magnetic coupling becomes the best selection for this exercise.

Keywords:

Electric motor, AUV, design steps, FAST.

Introduction

One of the aims of many Autonomous Underwater Vehicle (AUV) designers is to design low energy consumption systems so that the AUV can be operate longer [1]. However, not much attention had been given to the development of an electric motor as thruster in an AUV design, even though electric motor is a crucial part in AUV mobility. Without properly designed motor, the AUV might not be able to be maneuver effectively and efficiently within the limited energy provided by the vehicle's power source. To gain good efficiency, the design of the electrical characteristics of the motor should suite the character of designed AUV. In other word, the amount of power provided by the motor should be appropriately designed in accordance to the character of the AUV.

In order to achieve highest performance level from the motor, the motor should be able to provide smooth mechanical rotary motion to generate useful propulsion for the AUV with minimum energy consumption. The energy saved due to well designed motor should be used for more important components in the AUV operation and to prolong the performance duration of the vehicle. In order to satisfy those requirements, the motor should be carefully designed by considering its functionality. These functionality considerations should be embedded to the motor during the design stages.

In this paper, Functional Analysis System Technique (FAST) is deployed as one of the design tools for analyzing functionality considerations [2]. Based on that analysis, a proper design can then be established by applying the correct equations and appropriate decision making methods [3] to attain all the task and technical requirements that have been previously set up. The final outcome from this work is to establish a complete 3D drawing and engineering drawing of mechanical assemblies of underwater electric motor that complies to all its desired functions.

Design Steps for Underwater Electric Motor

Some considerations should be made in order to design an electric motor that would be used in deep water as the thruster motor of an AUV. The procedure for the design consists of seven steps. However performance of the first three preliminary steps is critical in order to ensure that all the aforementioned situations are included in the design. The followings are the steps in the proposed procedure:

- Step 1: Establish the task and technical requirements
- Step 2: Develop Function Analysis System Technique (FAST) diagram based on the requirement
- Step 3: Classify the result from the FAST diagram. The end result is in the form as shown in the Table 1.

After the three preliminary steps have been performed and revised, the following steps are performed:

Step 4: Solve the unknown results produced by FAST diagram. The action for this step is as follows: For end result type 2 as shown in Table 1, weighted method in decision matrix is employed. The flow of the process can be seen in Figure 1, for end result type 3, the appropriate equation can be found from handbooks, papers, or self-developed.

Table 1: FAST Diagram Classification Format

Types of end results	Description
Type 1 Ideal one final result	-no need further step
Type 2. Alternatives solution	-need further decision making method
Type 3. Need further calculation	-need engineering analysis before getting the final result

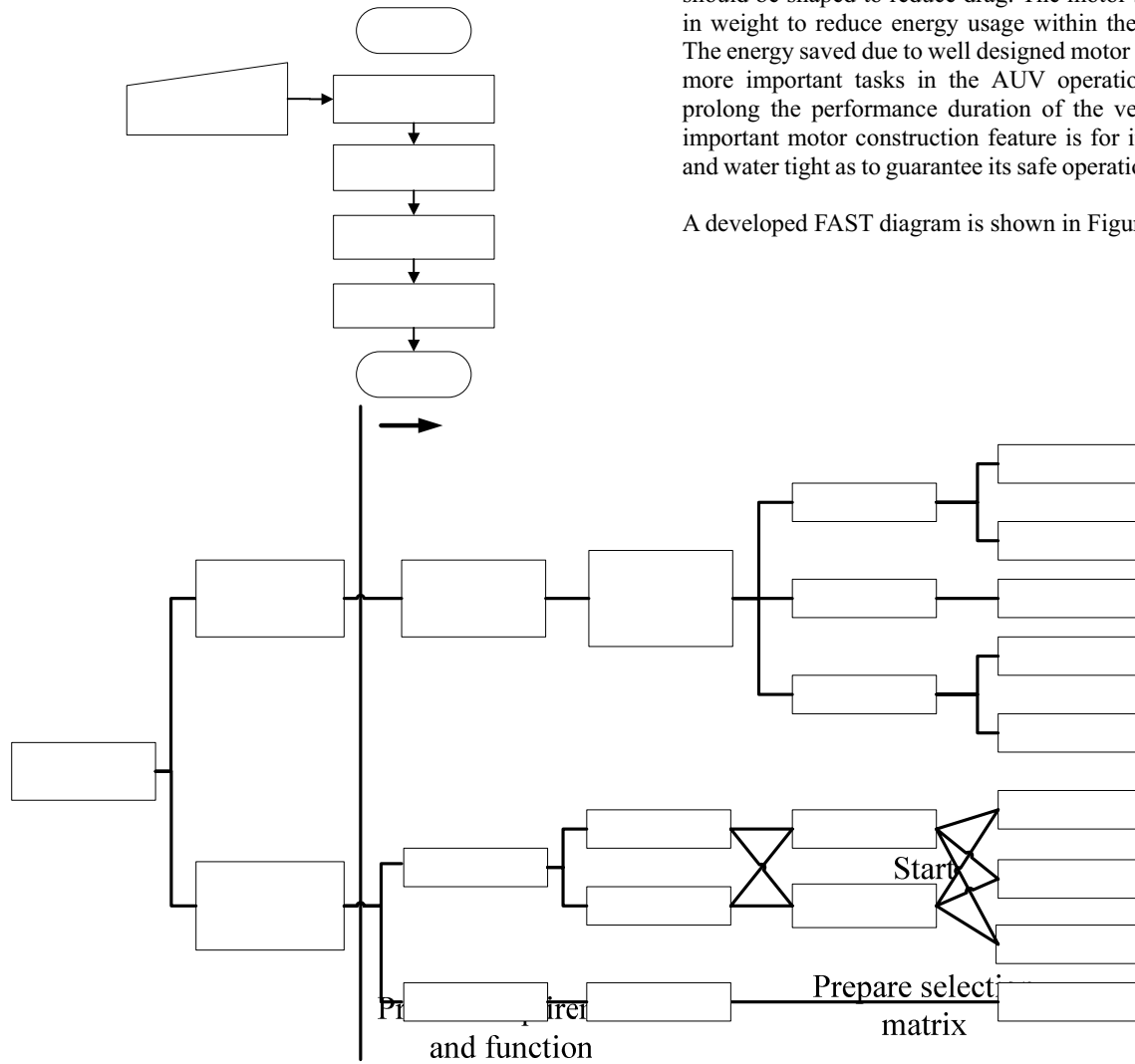

Figure 2 – FAST diagram

- Figure 1 – Flow chart of decision matrix method
- Step 5: Transform all solutions produced by 4th step into a general arrangement in a form of a sketch.
 - Step 6: Check the presence of all functionality that has been established by FAST diagram in the sketch.
 - Step 7: Produce the complete 3D drawing and general mechanical assemblies drawing

The result of the first three steps would be discussed. The remaining four steps are self explanatory therefore would not be discussed in this paper.

Results and Discussion

The task and technical requirement phase performed in Step 1 has identified that the motor should be able to provide smooth mechanical rotary motion to generate useful propulsion for the AUV with minimum energy consumption. The electric thruster motor must be operational at 300 meters in deep water. Another required feature is that the motor should be shaped to reduce drag. The motor should be light in weight to reduce energy usage within the AUV system. The energy saved due to well designed motor can be used for more important tasks in the AUV operation and also to prolong the performance duration of the vehicle. Another important motor construction feature is for it to be durable and water tight as to guarantee its safe operation under water.

A developed FAST diagram is shown in Figure 2 below.

Weight the criteria

Rate the concept

Based on the product requirements, there are two categories of the functions on underwater electric motor.

The first category is to provide rotary motion from the electric energy through the stator and rotor arrangement. These functions are supported by four alternatives that can be chosen to be used to connect the rotor (which produces the rotary motion) to the thrust mechanism of AUV under water tight condition as shown in the FAST diagram (Fig.2).

The second function category is to provide the motion with minimum energy. In this category, material properties and shape configuration are determined as factors that contribute to the level of energy consumption. From the perspective of material properties, light weight material will contribute to lower energy usage, while high strength material will prevent the motor from failure which ultimately can deteriorate the performance of the motor. Both these issues are highly dependent on the selection of material type and volume of material used. The type of material and its volume used will correspond to its mechanical properties such as yielding, buckling, and end-capping which can jeopardize the performance of the motor. Trade-offs of values of those properties can be attained by applying a set of engineering analysis. From the perspective of form, the best configuration is the one that induces minimum drag, thus reducing energy consumption and ease maneuverability.

Streamlined shape is believed can satisfy this requirement.

Based on the above descriptions, the resultant from FAST diagram can be classified in the format as shown in Table 2:

Table 2: Result of Classification

FAST result	Result type
Oil & seal Integrated motor/ pump impller Magnetic coupling Mechanical seal	Alternatives solutions (Type 2)
Yielding Buckling End capping	Need further calculation (Type 3)
Streamline	Ideal final result (Type 1)

From the Table 2, it is known that the function for water tight construction and material properties need to be studied further. Using the decision matrix, the optimal solution for water tight construction which has multiple alternatives (type 2), can be seen in Table 3. From the analysis of the decision matrix in Table 3, the most suitable water tight construction is to use magnetic coupling.

Table 3 – Decision Matrix of water tight condition

Selection criteria	Weight	Integrated motor/pump (reference)		Oil & seal		Magnetic coupling		Mechanical seal	
		Rating	Weighted score	Rating	Weighted score	Rating	Weighted score	Rating	Weighted score
Rate of power loss	15%	3	0.45	1	0.15	2	0.3	1	0.15
Efficiency	20%	3	0.6	1	0.2	2	0.4	2	0.4
Heat dissipation	10%	3	0.3	2	0.2	3	0.3	2	0.2
Complexity	10%	3	0.3	2	0.2	2	0.2	1	0.1
Cost	10%	2	0.2	4	0.4	5	0.5	1	0.1
Manufacturability	8%	2	0.16	2	0.16	4	0.32	1	0.08
Installation	8%	3	0.24	3	0.24	3	0.24	2	0.16
Weight	8%	2	0.16	5	0.4	3	0.24	5	0.4
Maintenance	6%	3	0.18	2	0.12	3	0.18	2	0.12
Environmental Effect	5%	3	0.15	2	0.1	3	0.15	3	0.15
Total Score		2.74		2.17		2.83		1.86	
Rank		2		3		1		4	
Selected solution		No		No		Yes		No	

To distinguish values for results of type 3, equations 1, 2 and 3, should be used before actual dimension being employed to each component [4]. The value from these equations will give the optimum thickness to diameter (T/D) ratio for each component. By using this equation, the minimum value of suitable material thickness that can withstand water pressure at 300m depth can be known.

T/D ratio to prevent buckling:

$$TD_{yield}(press) := \frac{1}{2} \left(1 - \sqrt{1 - \frac{2 \cdot press}{Y}} \right) \quad (1)$$

T/D ratio to prevent yielding:

$$TD_{\text{buckle}}(\text{press}) := \left[\text{press} \cdot \left(\frac{1 - \nu^2}{2 \cdot E} \right) \right]^{\frac{1}{3}} \quad (2)$$

T/D ratio to prevent end plate simply supported from failure:

$$TD_{\text{endplate}}(\text{press}) := \frac{1}{2} \cdot \sqrt{\frac{3 \cdot \left(\frac{3}{\nu} + 1 \right) \cdot \text{press}}{\frac{8}{\nu} \cdot Y}} \quad (3)$$

Where; press = $\rho_{\text{water}} \cdot g \cdot \text{depth}$, E= Young Modulus, Y=Yield Stress, ν =Poisson's Ratio.

When all the functions are fulfilled, general sketch of an underwater electric motor is drawn as shown in Figure 3.

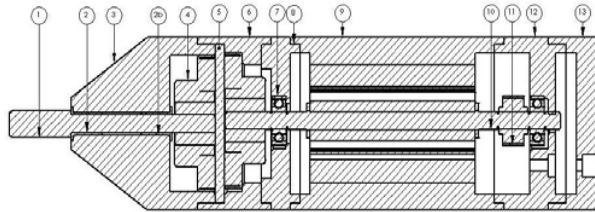

Figure 3: Sketch of underwater electric motor. 1-propeller shaft, 2- Flange bearing, 3- Bullet housing, 4-Magnetic Coupling, 5-Magnet separator, 6-Magnetic coupling housing, 7- Bearing housing, 8- Bearing housing, 9-Stator housing, 10-Rotor, 12-Rear bearing housing, 13- Sensor cap.

Lastly, a complete 3D with general engineering drawing of mechanical assemblies for underwater electric motor is shown in Figure 4.

Conclusion

The steps involved in the design of underwater electric motor have been discussed. A FAST diagram was employed to make sure that all the functionalities of the electric motor have been included into the design. This systematic approach of the design process has been presented to allow AUV designer to realize the role of the electric motor as means to generate the thrust which is useful for the AUV to maneuver without significant use of energy.

Acknowledgement

The author would like to thanks to the financial sponsor National Oceanographic Directorate (NOD) under Ministry of Science and Innovation (MOSTI).

References

- [1] Gerl, B. 2006. Development of an Autonomous Underwater Vehicle in an Interdisciplinary Context.

Diploma diss, Dept. of Electrical, Electronic, and Computer Engineering.

- [2] Bytheway, C.W. 2006. *FAST Creativity & Innovation*. U.S.A.:Jrosspub.

- [3] Ulrich, K.T., and Eppinger, S.D.2003. *Product Design and Development*. New York.:Mc Graw Hill.

- [4] Cortesi, R. 21 Jun 2002. Citing Internet Sources URL <http://www.pergatory.mit.edu>.

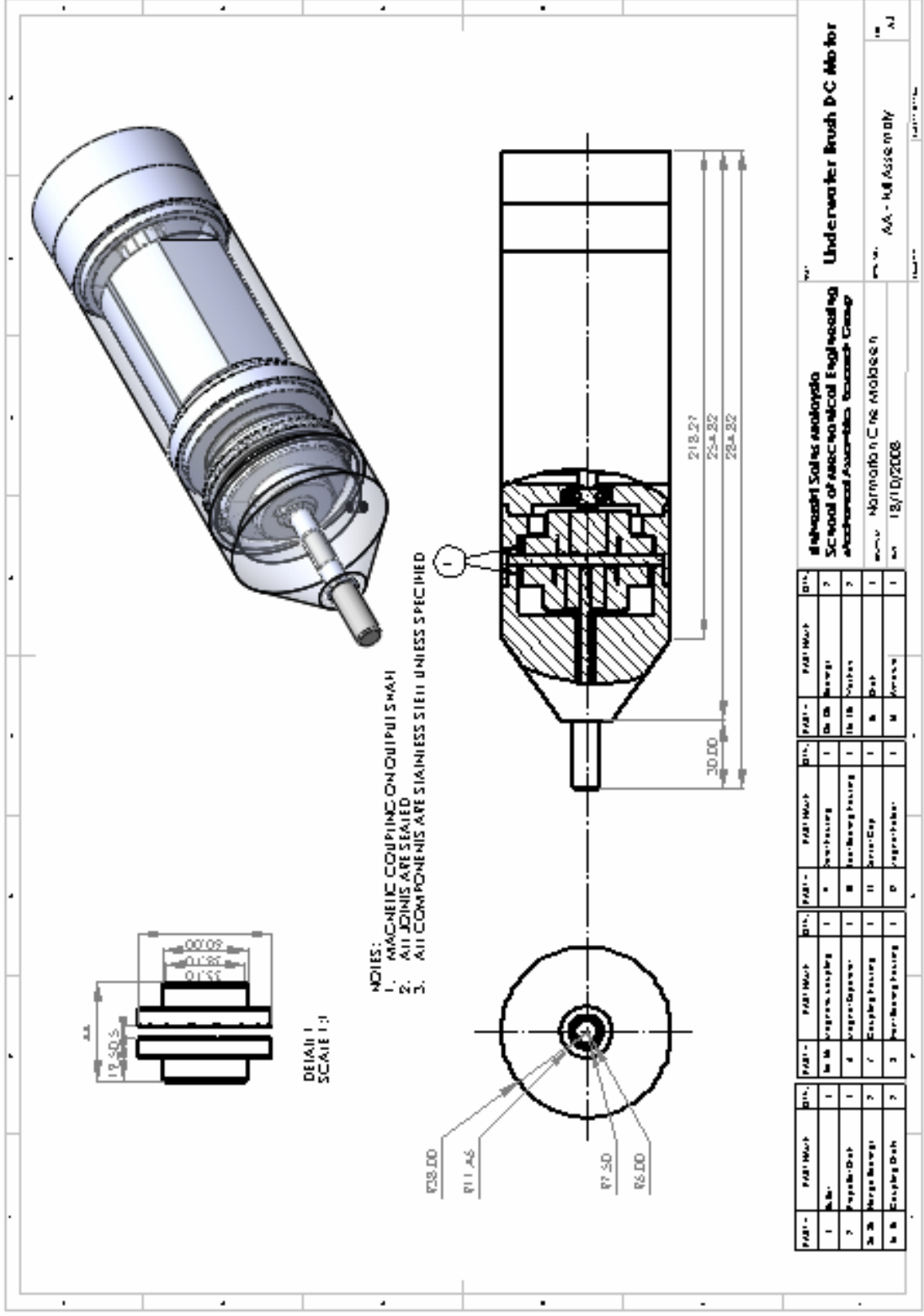

Figure 4: Completer 3D drawing with general engineering drawing