

UNIVERSITA' DEGLI STUDI DI NAPOLI

FEDERICO II

FACOLTA' DI SCIENZE MATEMATICHE, FISICHE E NATURALI

DOTTORATO IN SCIENZE CHIMICHE XVIII CICLO

2002-2005

Indirizzo: Sintesi, struttura e reattività delle molecole organiche

**Chemistry and phytotoxicity of secondary metabolites
from Mediterranean plants**

Tutor
Prof.ssa M. Della Greca

Candidata
Dott.ssa Francesca Cutillo

Relatore
Prof.ssa R. Lanzetta

Coordinatore Prof. Rosa Lanzetta

INDEX

•	SUMMARY	3
•	INTRODUCTION	8
•	MATERIALS AND METHODS	18
	General experimental procedures.....	18
	Extraction and isolation of compounds from <i>Brassica fruticulosa</i>	19
	Extraction and isolation of compounds from <i>Malva silvestris</i>	21
	Extraction and isolation of compounds from <i>Chenopodium album</i>	22
	Bioassays.....	28
	Spectroscopic data of isolated compounds.....	29
•	RESULTS AND DISCUSSION	52
	<i>Brassica fruticulosa</i>	53
	<i>Malva silvestris</i>	74
	<i>Chenopodium album</i>	90
•	BIOASSAYS	123
•	CONCLUSIONS	144
•	REFERENCES	147
•	FTICR: FOURIER TRANSFORM ION CYCLOTRON RESONANCE	157
	Investigation upon the charge state, conformation and RS20 interaction of Calmodulin.	
	Introduction.....	157
	FT-ICR Mass spectrometry.....	158
	ESI an nano-ESI.....	162
	Calmodulin structure and its biological role.....	164
	Results and discussion.....	166
	Experimental procedures.....	171
	References.....	173

SUMMARY

Chimica e fitotossicità di metaboliti secondari da piante della flora mediterranea

L'ecologia chimica è definita come “la comprensione ecologica dell'origine, della funzione e del significato delle sostanze chimiche che mediano l'interazione tra organismi differenti” (Anon, 2001). Lo studio ecologico di un organismo vegetale considera in che modo la pianta risente delle stimolazioni esterne e come queste ultime possano causare una mutazione del suo metabolismo. Le piante infatti, per competizione, difesa o empatia possono variare e indirizzare la propria produzione metabolica. L'accumulo di metaboliti tossici in particolari parti della pianta è uno dei possibili meccanismi deterrenti attivati dall'organismo vegetale per garantire la propria sopravvivenza. In casi opposti la pianta attiva la produzione di metaboliti in grado di attirare gli insetti impollinatori e salvaguardare la diffusione della propria specie. Meccanismi di interazione pianta-pianta sono altresì noti e descritti con il termine allelopatia, che considera le interazioni positive o negative che una pianta esercita su di un'altra mediante la produzione metabolica secondaria. Juglone, sulcotrione, scopoletina, 1,4-cineolo sono solo alcuni esempi di metaboliti fitotossici che, prodotti da una pianta, le consentono il predominio vegetale del proprio habitat. Alcuni dei composti allelochimici isolati presentano una bioattività tale da poter essere impiegati in campo agronomico come erbicidi naturali. Erbicidi di origine naturale potenzialmente possiedono caratteristiche di biocompatibilità (maggiore biodegradabilità e basso grado di bioaccumulo) difficilmente riscontrabili in un erbicida industriale. A ciò si aggiunge la maggiore specificità dei metaboliti naturali, perfezionati dall'evoluzione per agire in maniera altamente selettiva su targets di interesse. La natura come fonte inesauribile di strutture molecolari possiede la più immediata risposta alla ricerca di nuovi erbicidi

verso i quali le piante infestanti non abbiano sviluppato resistenza in seguito all'uso indiscriminato e continuativo.

In questa ottica il gruppo di ricerca presso il quale ho svolto il mio lavoro di tesi, ha negli anni studiato i metaboliti secondari prodotti da piante infestanti dell'area mediterranea. In particolare nel corso del mio ciclo di dottorato ho condotto l'analisi sistematica dei metaboliti secondari prodotti da tre piante spontanee dell'area mediterranea: *Brassica fruticulosa*, *Chenopodium album*, *Malva silvestris*.

Per ciascuna delle tre piante è stata realizzata l'estrazione dei metaboliti mediante diverse metodiche (infusione, estrazione in continuo), seguita da un processo di frazionamento degli estratti mediante tecniche cromatografiche (cromatografia su colonna di silice, cromatografia liquido-liquido in controcorrente, TLC e HPLC in fase diretta e inversa). L'impiego di tali tecniche ha consentito la purificazione delle frazioni e l'isolamento dei metaboliti. La caratterizzazione strutturale delle molecole isolate è stata realizzata con tecniche spettroscopiche, tra cui NMR mono e bidimensionale ($^1\text{H}^1\text{H}$ COSY, HMBC, HSQC, NOESY, ROESY), spettroscopia UV-VIS, dicroismo circolare e tecniche di spettrometria di massa (EI, ESI, MALDI).

Brassica fruticulosa è una pianta infestante appartenente alla famiglia delle Brassicaceae, che include più di 2000 specie distribuite in tutto il mondo e ampiamente diffuse in Italia. Le specie presenti nel nostro paese sono un'importante risorsa economica, sono infatti adoperate come ortaggi, foraggi per animali, fertilizzanti o per l'estrazione di oli da condimento o industriali. Alcune varietà presentano proprietà farmacologiche (antiscorbuto, emetiche, diuretiche, antiallergiche).

L'estrazione dei metaboliti da *Brassica fruticulosa* è stata realizzata ponendo la pianta fresca in infusione in una soluzione idroalcolica (10% MeOH/H₂O) e successivamente in metanolo. Gli infusi ottenuti sono stati sottoposti ad estrazione con solventi a polarità

crescente, in modo da realizzare un primo frazionamento dei metaboliti, successivamente purificati attraverso le metodiche cromatografiche descritte.

Da *Brassica fruticulosa* sono stati isolati tredici lignani (Cuttillo et al. 2003) e cinque *nor*-terpeni (Cuttillo et al. 2005).

I lignani sono metaboliti costituiti da unità di tipo fenilpropanico legate tra loro in strutture polimeriche costituenti le lignine. Le lignine sono polimeri naturali coinvolti nel processo di lignificazione della parete cellulare e responsabili delle strutture rigide delle piante e degli alberi, esse inoltre partecipano ai meccanismi difensivi degli organismi vegetali in condizioni di stress biotico. E' nota l'attività antimicrobica, antivirale, erbicida e antifeedant di numerosi lignani (Russell et al. 1976), si è dimostrato inoltre un effetto preventivo anticancro dei lignani assunti con la dieta (Thompson et al. 1996).

I *nor*-terpeni sono molecole a tredici atomi di carbonio, probabilmente derivanti dalla degradazione di carotenoidi. Essi sono responsabili dell'aroma di frutti, ortaggi, spezie, tabacco e di vari tipi di tè.

Chenopodium album appartiene alla famiglia delle Chenopodiaceae, è una pianta annuale infestante delle colture estivo-autunnali, diffusa non solo nell'area mediterranea, ma anche nel continente americano.

Anche l'estrazione dei metaboliti da *C. album* è stata realizzata attraverso processi infusivi, e procedure cromatografiche sono impiegate per la purificazione e l'isolamento. Sono state così isolate sette ammidi cinnamiche (Cuttillo et al. 2003) variamente funzionalizzate con gruppi ossidrilici ed esterei, un'ammide cinnamica legata ad un residuo alcaloidico di tipo protoberberinico (Cuttillo et al. 2004), diciotto *nor*-isoprenoidi (Della Greca et al. 2004), tredici derivati fenolici e otto lignani (Cuttillo et al. in press).

Malva silvestris è una pianta spontanea del Mediterraneo appartenente alla famiglia delle Malvaceae, nota fin dall'antichità per le sue proprietà antinfiammatorie, emollienti e lassative, trova largo impiego in fitoterapia.

L'estrazione dei metaboliti è stata realizzata con acqua adoperando un estrattore automatico in continuo, l'estrattore *Naviglio* (2003). Quest'ultimo è un estrattore solido-liquido che applica una serie di cicli di lavoro in cui il solvente è successivamente pompato a moderata pressione nella camera di estrazione contenente la pianta.

L'infuso acquoso è concentrato e frazionato con tecniche cromatografiche. Sono stati in tal modo isolati undici derivati fenolici e dieci terpenoidi.

Alcuni dei metaboliti isolati dalle tre piante sono stati sottoposti a saggi di fitotossicità su un organismo vegetale di riferimento *Lactuca sativa* (lattuga) allo scopo di valutare l'effetto inibente o stimolante la germinazione, l'allungamento radicale e l'allungamento dell'ipocotile dell'organismo vegetale testato. I saggi sono stati condotti in accordo alla procedura ottimizzata da *Macias et al.* (2000).

Durante il mio dottorato ho avuto modo di approfondire la conoscenza di tecniche di spettrometria di massa, grazie ad un periodo di formazione speso presso l'Università di Warwick (UK), usufruendo di una borsa di studio europea Marie Curie.

Presso tale Università ho operato su uno spettrometro di massa ciclotronico a trasformata di Fourier (FTICR, Fourier Transform Ion Cyclotron Resonance) accoppiato ad una sorgente electrospray (ESI) o nanospray (nano-ESI). Tale strumento consente di raggiungere alti valori di sensibilità, risoluzione e accuratezza nella misura di spettri, tali da rendere la tecnica ideale per lo studio di un ampio spettro di substrati, da biomolecole ad alto peso molecolare a molecole organiche di dimensioni ridotte (*Amster 1996*). Il funzionamento dello strumento è basato sulla possibilità di rivelare il moto ciclotronico di una popolazione di ioni. Gli ioni generati nella sorgente ESI

raggiungono, attraverso un sistema di ottiche, l'analizzatore (Infinity Cell) dello spettrometro di massa. Esso è costituito da una cella cilindrica esternamente alla quale è applicato un campo magnetico (**B**) di direzione parallela all'asse del cilindro. Le molecole di massa *m* e carica *q* sotto l'azione del campo magnetico iniziano un moto circolare (ciclotronico) di frequenza pari a:

$$f = \frac{qB}{2\pi m}$$

L'applicazione di un circuito elettrico consente di rivelare la frequenza del moto ionico.

La trasformata di Fourier dell'interferogramma fornisce lo spettro di massa.

La spettrometria di massa FTICR è stata da me applicata per lo studio della Calmodulina e dei suoi stati conformazionali in soluzione acquosa e organica. La calmodulina è una proteina costituita da 148 residui aminoacidici, legati a costituire una molecola a forma di manubrio, avente due domini globulari legati da una α -elica. Ciascuno dei due domini ospita due siti specifici per il calcio, che rendono la calmodulina una proteina coinvolta in numerosi processi calcio-regolati, responsabili della trasmissione dei segnali cellulari. Mediante spettrometria di massa sono state anche analizzate le modalità di interazione della calmodulina con il peptide RS20, un peptide sintetico ottenuto come analogo derivato del sito di fosforilazione della Myosina Light Chain Kinase, enzima coinvolto nel processo di contrazione muscolare. Lo studio di massa mostra come l'interazione tra RS20 e calmodulina preveda dapprima uno stadio in cui in la calmodulina lega il peptide, seguita da una fase in cui il complesso lega quattro atomi di calcio (*Hill et al. 2000*).

INTRODUCTION

Observation of plants ecosystem clearly suggested that plant survival is affected by many factors, including resources competition, defence from herbivores and climate threats, and defence from other plant attacks. The common perception of a plant being a passive organism, only responding to fluctuations in the resources it requires, has been long since discounted. It is widely accepted that plants can interact with other plants, microbes or animals by releasing and receiving chemicals (*Inderjit and Duke 2003*).

In 1937 *Molish* coined the term Allelopathy to describe the phenomenon that one plant can influence another. A more extensive definition was given by *Rice* in 1984, who defined Allelopathy as the effect of a plant (including microorganism) on the growth of another plant through the release of chemical compounds in the environment. Both positive and negative effects are included in this definition, which is generic enough to cover many aspects of the chemical ecology of plants. The criteria for establishing evidence of allelopathy are still a matter of debate, the six principles proposed by *Willis et al. (1985)* were successively summarized (*Blum et al. 1999*) in the three following characteristics that an allelopathic organism is required to have:

1. The allegedly allelopathic plant must produce and release chemicals that modify the growth of other plants.
2. The amount of inhibiting substances produced must be sufficient to affect vital processes of the sensitive plants, like nutrient and water uptake by roots or energy fixation.

3. Physical or biotic factors cannot be sufficient to explain the observed plant inhibition in field patterns.

Demonstrating that a plant has the described criteria is not an easy task. *Inderjit and Nielsen (2003)* have discussed the problems related to allelochemical collection and quantification, interactions between allelochemicals and other chemicals, selection and concentration of these compounds in bioassays, bioassays fitting in fields.

Nevertheless many experiments have been carried out to identify an allelopathic organism. Inhibition zones around the plant, wide spontaneous monoculture area, and root segregation are realistic ecological features in which to investigate allelopathy (*Inderjit and Callaway, 2003*). The finding of phytotoxins in the rhizosphere, density-dependent experiments to distinguish allelopathy and resource competition effects (*Weidenhamer et al., 1989*), reduction of the negative power of one plant on the others by using substances with organic adsorptive capacity (activated carbon, gel filters) (*Mahall and Callaway, 1992*) to alter the rhizosphere chemistry, are just some of the more persuasive experiments that provide a deeper insight into allelopathy.

Allelochemical action is launched when the allelochemicals are released in the environment. This may happen through different processes, including foliar leaching, root exudation, residue decomposition, volatilisation and debris incorporation into soil (*Inderjit and Weston 2003*). Once released, phytotoxins diffuse in the soil transported by water. It has also been demonstrated that allelopathic interaction can occur between organisms through root to root contact (*Inderjit and Weston 2003*).

Allelochemicals so far identified belong to different classes of chemical compounds, as terpenoids, quinones, saponins, coumarins, tannins, flavonoids, cinnamic and benzoic acids, alkaloids.

Terpenoid class includes a wide range of mono-, di-, tri-, sesqui-, and tetraterpenoids. *Macias et al. (1999)* have described an impressive array of terpenoids all isolated from sunflower that are responsible for inhibiting activity.

Mechanisms of action have been studied for some chemicals having a well-proved allelopathic activity, but no unique way of interaction with cells has been found for structural related compounds.

One of the first mechanisms of action described for allelochemicals was reported by *Muller (1965)*, showing that the volatile 1,8-cineole and camphor reduce cell division causing a shorter root cells elongation and the generation of cells with irregular nuclear and large internal globules. It was successively reported that these monoterpenes cause structural modifications of small cellular organelles and the disruption of the nuclear membrane and other internal membranes.

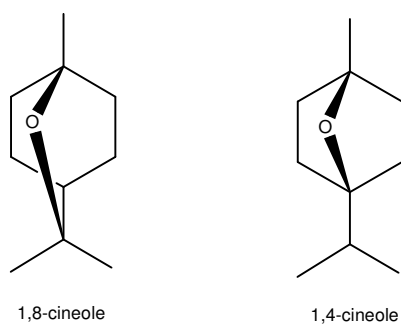

A natural analogue of 1,8-cineole is 1,4-cineole, which has been shown to be a potent inhibitor of asparagine synthetase, which is involved in nitrogen metabolism. The displacement of the oxygen bridge within the two monoterpenes described, deeply modifies the biological effects.

Two significant examples of bioactive quinones are juglone and sorgoleone (Einhellig 2001). They are described as having a role in *black walnut* and *Sorghum* allelopathy, respectively. They are both active at very low concentrations, several orders of magnitude lower than many allelochemicals from higher plants. It has been reported that both compounds affect plant energy metabolism, but it is still unclear what the target sites are.

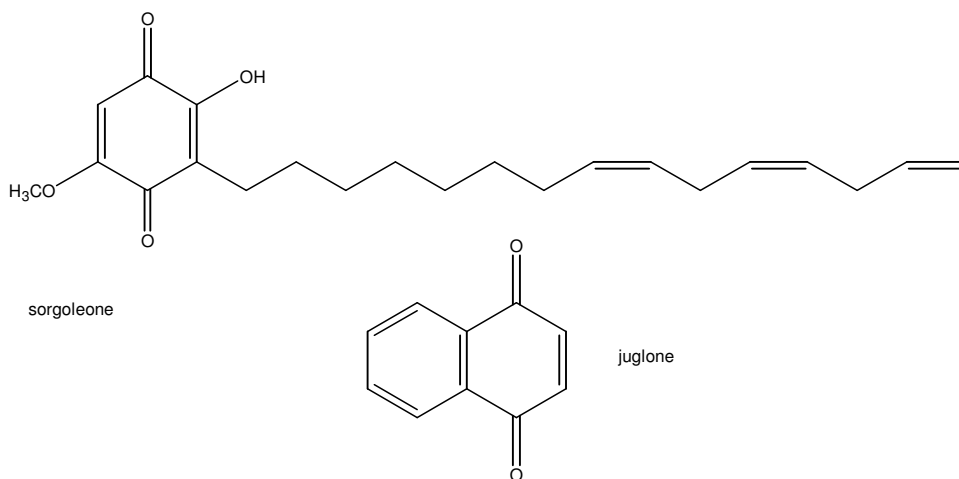

Many bioactive coumarins were isolated from plants and their action mechanisms are broadly distributed, including an internal role in seed dormancy by retarding cellular development (Aliotta *et al.*, 1994). Coumarin and scopoletin both decrease mitosis, and an inhibiting action on indoleacetic acid oxidation by scopoletin has been demonstrated. Einhellig *et al* (1970) proved that roots-absorbed scopoletin was transferred to shoots, where it decreased the photosynthesis rate, probably by stomatal closure.

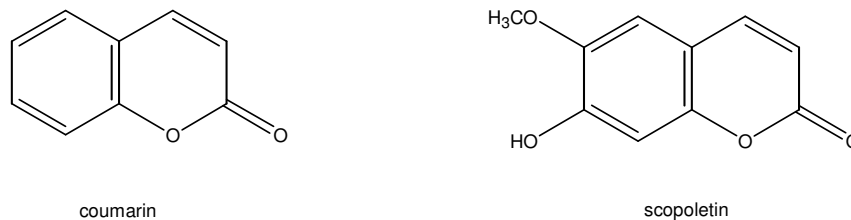

Cinnamic and benzoic acids production has been reported for many allelopathic plants. In their mode of action these compounds do not have a specific molecular target. Effects have been reported on several phytohormone interactions, ion uptake and content, photosynthesis, respiration, chlorophyll maintenance, membrane structures and ATPases transport, patterns of carbon flow, and a variety of enzymes. All these effects are said to be caused by ferulic acid, one of the better-studied phenolic acids, in higher plants (*Einhelling 1986, Reigosa et al. 1999*).

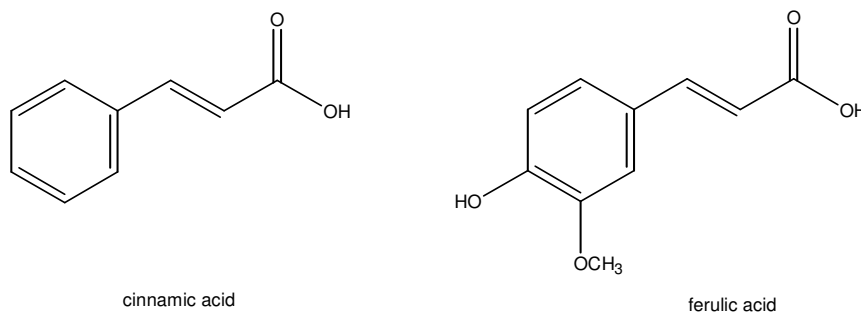

Secondary metabolites produced by plants and having biological activity have been broadly described in literature but only a small subset has been studied in connection with allelopathy, and their action mechanism is still far from being understood. Thus there is still a wide array of natural compounds to be investigated for a more complete view of allelopathy.

Allelochemicals produced by a plant may act as phytotoxins on the plant itself. Two possible mechanisms might prevent a plant from poisoning itself: a) resistance at the molecular target site b) processes that avoid the allelochemical to interact with the molecular target site. While there is no evidence for the first mechanism, the second one is supported by several examples. Phytotoxins are kept away from the molecular target through sequestration and chemical protection. Sequestration is realized by the compartmentalization of the toxic chemicals in cell areas which are not in contact with vital centres, as in vacuoles

and trichomes. In some cases phytotoxins are modified by enzymatic processes that bond sugars or other moieties. In this way the modified phytotoxins can be transported to a vacuole. The modified compounds are usually less phytotoxic, and their negative activity is even weaker when they are stored within vacuoles. These compounds usually become phytotoxic only after they are released into the soil, where they are probably activated by the enzymatic removal of the function employed to ensure vacuole sequestration.

Chemical modification of allelochemicals is sometimes performed by plants, according to a species selected process, in order to lessen the phytotoxic effects of other species. Detoxification processes include oxidation, carbohydrate or other chemical conjugation, and segregation in depository cell compartments before excretion. These kinds of plant reactions are also observed in response to herbicide treatments.

Toxic activity of allelochemicals suggests the use of these compounds in weed management. The natural origin of these chemicals often means eco-compatibility, low bioaccumulation, highly specific mechanisms of action. For all these features allelochemicals are suitable for use as herbicides, both directly or after chemical modification that implements physico-chemical properties.

Herbicides designed by chemical synthesis have quite unspecific molecular target sites, usually aimed at undermining generic vital functions of the cell, causing drawbacks also to crops. Evolution, instead, selected a broad array of efficient and selective phytotoxins, which can be used as templates for new herbicides. Increasing the weeds resistance to common herbicides has aroused deep interest in the discovery of new molecular target sites for herbicides.

Most phytotoxins are too weakly allelopathic to be considered for the direct use as herbicides. They often show a very weak activity at millimolar concentration in bioassays, and much higher concentrations would be required in soil.

However, many plant-produced phytotoxins preserve their bioactivity at a micromolar level, making them potential candidates for industrial applications.

An interesting example is tentoxin (*Duke et al. 1987*), a cyclic tetrapeptide from the plant pathogen *Alternaria alternata*. This compound has a really attractive soil behaviour. In fact, it shows high stability with good residual soil activity which is mainly exerted against an important spectrum of weed species. Several major crops are completely resistant to tentoxin toxicity. The only obstacle for tentoxin industrial application is its structural complexity, and all the efforts to find a simpler analogue with the same desirable properties, have been vain.

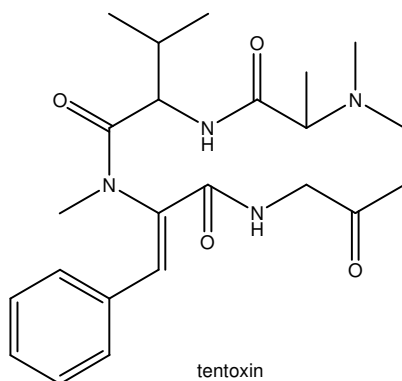

Another interesting natural compound is sorgoleone, which is a plant-produced quinone, structurally related to plastoquinone. Together with many of its analogues, sorgoleone inhibits photosystem II of photosynthesis, apparently by preventing the binding of plastoquinone to the D-1 protein of PSII (*Rimando et al. 1998*). Unfortunately it does not show proper physico-chemical properties required to be applied directly as a herbicide.

In spite of the wide array of phytotoxic natural compounds isolated, just a few of them can be effectively applied as herbicides. This is mainly due to the structural complexity of natural molecules, which requires multi-step synthesis and considerable production costs. In many cases the slightest simplification of the natural structure nullifies biological activity; so analogue planning does not always guarantee efficient results.

Nevertheless there are many commercial herbicides deriving structurally from allelopathic compounds.

An interesting example is provided by a herbicide widely used in Europe and Asia, cynmethylin. This herbicide is structurally similar to 1,4-cineole, a natural monoterpene, which acts on a target plant by inhibiting asparagine synthetase (*Romagni et al. 2000*), a previously unexploited molecular action site. The inhibition of this enzyme causes an interruption of plant growth. It seems that Cynmethylin is a pro-herbicide that requires metabolic bioactivation in soil by cleavage of the benzyl-ether side chain, giving a molecule with a 1,4-cineole structure, responsible for the allelopathic activity (*Romagni et al. 2000*).

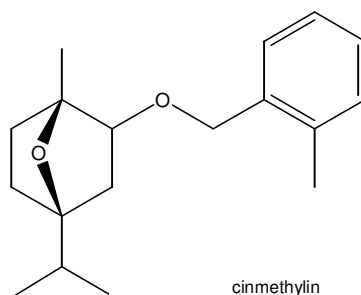

For agricultural purposes different kinds of triketone herbicides structurally derived from the natural compound leptospermone are widely used. Two interesting examples are sulcotrione and mesotrione (*Lee et al. 1997, Knudsen et*

al. 2000). These kinds of triketone herbicides act on the enzyme *p*-hydroxyphenylpyruvate dioxygenase, which is an enzyme involved in the biosynthesis of carotenoids and plastoquinone. The inhibition of its activity causes foliage bleaching in the treated plants, due to the loss of chlorophyll.

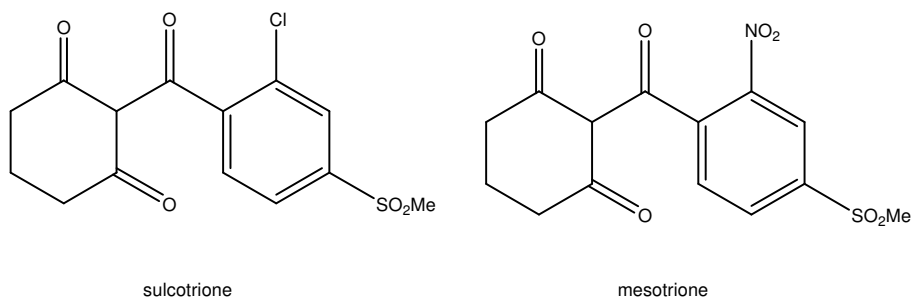

Recently another interesting application of allelopathic studies has been proposed. Biotechnology researches are aimed at designing crops in which genetic modifications induce allelochemical production, or implement an already existing allelopathic activity. Even though this approach to the use of herbicides seems to possess many advantages, a serious and extensive research is required if we are to be totally aware of all the consequences related to the genetic engineering of crops.

The investigation of allelopathic compounds is just a small part of the studies of natural compounds. Nature still represents an infinite source of unknown molecules having new structures and functionalities that evolution refined for high specific biological roles. The functional-group diversity and architectural models of carbon skeletons designed by nature continue to provide lessons for synthetic and medicinal chemists in their strategies for making biological active mimics. Biosynthetic pathways of natural compounds also provide interesting suggestions for monomer assembling and the tailoring of the growing product,

which can be used to create new strategies for synthesising variants of natural products (*Clardy et al. 2004*).

During my PhD project I have been working in a research group that has studied different plants of the Mediterranean area for many years, trying to detect and investigate their allelopathic activity (*Della Greca et al. 1994, Della Greca et al. 2004, Della Greca et al 2003*). Personally I have been concerned with the isolation and identification of secondary metabolites produced by three spontaneous plants of the Mediterranean area: *Brassica fruticulosa*, *Chenopodium album* and *Malva silvestris*. The extraction of metabolites from these plants was realized by infusion in hydro-alcoholic solution for *Brassica fruticulosa* and *Chenopodium album*. Instead, an automatic extractor (Naviglio extractor) (*Naviglio 2003*) was used for *Malva silvestris*. Fractionation and purification of the extracts were realized by different chromatographic techniques (CC, HPLC, TLC, DCCC), while pure compound identification was possible with spectroscopic techniques (^1H and ^{13}C NMR, UV-VIS, CD, IR) and spectrometric techniques (ESI-MS, GC-MS, MALDI-MS). Characterized compounds have been tested on seeds of target plants to detect their bioactivity, in accordance with a procedure defined by *Macias et al. (2000)*.

MATERIALS AND METHODS

General Experimental Procedures. Nuclear magnetic resonance (NMR) spectra are recorded at 500 MHz for ^1H and 125 MHz for ^{13}C on a Varian 500 Fourier transform NMR spectrometer. Electronic impact mass spectra (EI-MS) are obtained with a HP 6890 spectrometer equipped with an MS 5973 N detector. Matrix Assisted Laser Desorption Ionization (MALDI) mass spectra are recorded using a Voyager-DE MALDI-TOF mass spectrometer. UV/Vis spectra are recorded in ethanol on a Perkin-Elmer Lambda 7 spectrophotometer. The CD curves are measured with Jasco J-715 dichrograph. The preparative DCCC apparatus consists of a Tokyo Rikakikai Ltd system equipped with 300 tubes (400 x 2.0 mm). The analytical HPLC apparatus consists of an Agilent 1100 HPLC system equipped with a UV detector. The column is a 250 mm x 4.6 mm i.d., 5 μm Hibar LiChrosorb RP-18 (Merck). The preparative HPLC apparatus consists of a Shimadzu LC-10AD pump, a Shimadzu RID-10A refractive index detector, and a Shimadzu Chromatopac CR-6A recorder. Preparative HPLC is performed using a 250 mm x 10 mm i.d., 10 μm Luna NH_2 , RP-8 and RP-18 column (Phenomenex). Analytical TLC is made on Kieselgel 60 F₂₅₄ or RP-18 F₂₅₄ plates with 0.2 mm layer thickness (Merck). Spots are visualized by UV light or by spraying with $\text{H}_2\text{SO}_4/\text{AcOH}/\text{H}_2\text{O}$ (1:20:4). The plates are then heated for 5 min at 110 °C. Preparative TLC is performed on Kieselgel 60 F₂₅₄ plates with 0.5 or 1 mm film thickness (Merck). Flash column chromatography (FCC) is conducted on Kieselgel 60, 230-400 mesh (Merck), at medium pressure. Column chromatography (CC) is performed on Kieselgel 60, 70-240 mesh (Merck), or on Sephadex LH-20 (Pharmacia).

Extraction and Isolation of Compounds from *Brassica fruticulosa* . *B. fruticulosa* was collected in Italy (Caserta) during Spring and identified by Professor Assunta Esposito of Dipartimento di Scienze della Vita of II University of Naples (CE 38). Fresh leaves (15 kg) were infused with 10% MeOH/ H₂O for 7 days and then with methanol for 5 days.

The MeOH/ H₂O extract was reduced in volume and partitioned between CH₂Cl₂ and H₂O. The CH₂Cl₂ extract (20 g) was subjected to silica gel column chromatography, using CHCl₃ and successively increasing ethyl acetate (EtOAc) by 5, 25, 50, 80, and 100% in CHCl₃. Fractions of 200 mL were collected and the fractions with similar TLC profiles were combined to produce 35 fractions. Fractions eluted with 5% EtOAc were purified by flash silica gel column chromatography with CHCl₃/EtOAc (7:3) and then on a Sephadex LH-20 column with hexane/CHCl₃/MeOH (3:1:1) to give pure **1**. Two fractions were eluted with 50% EtOAc, fractions A and B. Fraction A was purified by DCCC [CHCl₃/MeOH/H₂O (11:10:9)] using the more polar upper layer as mobile phase. Fractions 51-80 were chromatographed by reverse phase C-8 HPLC [H₂O/CH₃CN (7:3)] to give pure **2** and **4**. The fraction eluted with 80% EtOAc was purified by DCCC [CHCl₃/MeOH/H₂O (11:10:9)]. Fraction B was chromatographed on silica gel column with CHCl₃/EtOAc (3:2), fractions 12-23 obtained were purified by TLC Hexane/EtOAc (6:4) to give pure **14**.

Fractions 40-60 were chromatographed by reverse phase C-8 HPLC [H₂O/MeOH/CH₃CN (7:2:1)] to give pure **5**.

Fractions 61-85 were purified by HPLC on a NH₂ column [CHCl₃/MeOH (9:1)], giving pure **9** and **12**.

Purification of fractions 86-112 was made with preparative TLC [CHCl₃/MeOH/H₂O (33:30:35)], using the organic lower layer as mobile phase to give pure **6** and **8**.

Fractions 113-150 were separated by Sephadex LH-20 column chromatography with 20% MeOH in CHCl₃ and subsequently purified by preparative TLC [EtOAc/MeOH/H₂O (8:1:10)] to give pure **11**.

The fraction eluted with 100% EtOAc was purified by DCCC [CHCl₃/MeOH/H₂O (11:10:9)] using the more polar upper layer as mobile phase. Fractions 31-50 were chromatographed by preparative TLC [EtOAc/CHCl₃ (1:1:)] to give pure **15**.

The concentrated water layer (2 L) was chromatographed on Amberlite XAD-2 with water and methanol. The MeOH fraction (100 g) was rechromatographed on Sephadex LH-20 with H₂O and increasing MeOH by 20, 30, 50 and 80% in H₂O up to 100%.

Fractions eluted with 100% H₂O were purified by silica gel column chromatography, using the organic layer of the solution CHCl₃/MeOH/H₂O (13:6:5) as mobile phase. Fractions 10-20 were chromatographed by HPLC on a C-18 column [H₂O/MeOH/CH₃CN (6:3:1)] to give pure **17**.

Fractions eluted with 20% MeOH were purified by silica gel flash column chromatography with CHCl₃/MeOH/H₂O (13:6:5) and then by reverse phase C-8 HPLC [H₂O/MeOH/CH₃CN (3:1:1)], to give pure **7**.

Fractions eluted with 30% MeOH were purified by DCCC [CHCl₃/MeOH/H₂O (13:6:5)] using the more polar upper layer as mobile phase. Fractions 35-60 were chromatographed by HPLC on a NH₂ column [CH₃CN/H₂O (9:1)] to give pure **3**.

Preparative TLC, CHCl₃/MeOH (9:1) of purified fractions 61-85 gave pure **13**.

Fractions eluted with 50% MeOH were purified by DCCC [CHCl₃/MeOH/H₂O (7:13:9)] using the more polar upper layer as mobile phase. Fractions 55-74 were chromatographed by reverse phase C-8 HPLC [H₂O/MeOH/CH₃CN (7:2:1)] to give pure **10**.

The methanol extract was reduced in volume and partitioned between EtOAc and water. The ethyl acetate extract (20 g) was subjected to silica gel column chromatography, using CHCl_3 and successively increasing the acetone. Fractions eluted with 10% acetone were purified by C18-HPLC [$\text{H}_2\text{O}/\text{MeOH}/\text{CH}_3\text{CN}$ (3:5:2)] to give pure **16**.

The water extract was concentrated and then partitioned between CH_2Cl_2 and water. Concentrated water portions were chromatographed on Amberlite XAD-2, eluting with water and increasing methanol. Fraction eluted with 50% MeOH in water was fractionated on Sephadex LH-20 with water, fractions 10-20 were purified by preparative TLC [$\text{MeOH}/\text{CHCl}_3$ (1:4)] to give pure **18**.

Extraction and Isolation of Compounds from *Malva silvestris*. Aerial part of plants of *M. silvestris* were collected near Caserta (Italy) in the Spring of 2003 and identified by Professor Antonino Pollio of the Dipartimento di Biologia Vegetale of University of Naples. Voucher specimens (HERBNAQA650) are deposited at the Dipartimento di Biologia Vegetale of University Federico II of Naples. Fresh leaves (10.0 kg) of the plant were extracted with H_2O at room temperature using Naviglio extractor. The water was reduced in volume and partitioned between ethyl acetate and water. The organic extract (19 g) was subjected to silica gel column chromatography, using CHCl_3 and successively increasing the ethyl acetate by 25, 50 and 80% in CHCl_3 . Fractions of 200 mL were collected and the fractions with similar TLC profiles were combined. The first fraction eluted with 100% CHCl_3 was purified by flash silica gel column chromatography with hexane-ethyl ether (1:1) to give fractions containing compounds **32-35**, **14**, **16** and **17**. The fraction containing crude **32** was purified by reverse phase C-18 HPLC with $\text{MeOH}-\text{CH}_3\text{CN}-\text{H}_2\text{O}$ [(1:6:3)]. Compounds **14**, **33** and **34** were purified by preparative TLC with CHCl_3 -acetone (7:3). The fraction containing crude **35** was

purified by preparative TLC with CH₂Cl₂-MeOH-H₂O (11:10:9). Compounds **16**, and **17** were purified by preparative TLC CHCl₃-MeOH (19:1). The second fraction eluted with 100% CHCl₃ was extracted with NaOH 2 N and the water fraction, after neutralization, was extracted with ethyl acetate to give 600 mg of residual material. Column chromatography on silica gel gave a fraction containing **22**, **26** and **31**. Compound **22** was purified by preparative TLC with CH₂Cl₂-MeOH-H₂O (33:30:35) lower layer. Compounds **26** and **31** were purified by C-18 HPLC with H₂O-MeCN-MeOH (7:2:1). Fractions eluted with 50% EtOAc were purified by flash silica gel column chromatography using CH₂Cl₂ and successively increasing acetone by 0, and 50 % in CH₂Cl₂. Fractions eluted with 100% CH₂Cl₂ were rechromatographed on silica gel under the same conditions. Subfraction eluted with 10% acetone was purified by C-18 HPLC with MeOH-H₂O (4:3) to give compounds **19**, **20**, **25**, **28** and **29**. Subfraction eluted with 15% acetone was purified by C-18 HPLC with MeOH-H₂O (4:3) to give compounds **21**, **23**. Subfraction eluted with 50% acetone was purified by C-18 HPLC with MeOH-MeCN-H₂O (4:1:5) to give compound **24**. Fraction eluted with 50% acetone was rechromatographed on silica gel using CH₂Cl₂ and successively increasing the acetone by 20, 40, and 50% in CH₂Cl₂. Fraction eluted with 20% acetone was purified by C-18 HPLC with MeOH-MeCN-H₂O (3:2:5) to give **36**. Fraction eluted with 40% acetone was purified by C-18 HPLC with MeOH-MeCN-H₂O (4:1:5) to give **30**. Fraction eluted with 50% acetone was purified by preparative TLC with EtOAc – acetone (19:1) to give **27**.

Extraction and Isolation of Compounds from *Chenopodium album*. Plants of *C. album* L. were collected near Caserta (Italy) during the Autumn of 2002 and Professor Antonino Pollio of the Dipartimento di Biologia Vegetale dell'Università Federico II di

Napoli identified them. Voucher specimens (HERBNAPY620) are deposited at the Dipartimento di Biologia Vegetale dell'Università di Napoli.

Leaves (15 kg) and twigs (9 kg) were separately and sequentially extracted with 10% MeOH/ H₂O and methanol at room temperature for 7 days. The extracts were frozen and stored at -80°C until used.

Hydroalcoholic leaf extract fractionation. Cold acetone (1.0 L) was added to the aqueous suspension (750 mL) of the hydroalcoholic extract (180 g), and the mixture was placed on a stir plate in a cold room overnight. The acetone addition produced heavy precipitation, consisting mostly of proteinaceous material, which was removed by centrifugation.

The solution was concentrated under reduced pressure and extracted with dichloromethane (1.0 L). The organic phase was concentrated and subjected to Flash Column Chromatography (FCC), giving ten different fractions.

Fraction 2 (12 g) eluted with dichloromethane was rechromatographed on FCC. Subfraction 4 (1.5 g), eluted with *n*-hexane: dichloromethane (4:1), was rechromatographed on FCC and, the 1st fraction eluted with *n*-hexane : ethyl acetate (19:1) gave **45**. Subfraction 5 (377 mg), eluted with *n*-hexane : acetone (4:1), was rechromatographed on FCC. Fraction 4, eluted with *n*-hexane : acetone (4:1) was purified by preparative TLC [*n*-hexane : acetone (4:1)] to give pure **39**. Subfraction 9 (275 mg), eluted with *n*-hexane : acetone (1:1), was rechromatographed on Sephadex LH-20 using *n*-hexane : chloroform : methanol (1:3:1) to give 5 fractions. The 4th (121 mg) was rechromatographed on FCC. The fraction eluted with dichloromethane : acetone (9:1) was purified by RP-18 HPLC with methanol : water (1:1) to give **1**. The 5th (25 mg), containing compounds **42** and **43**, was purified by RP-18 HPLC with methanol : water [(3:7), 5 and 4 mg, respectively]. Subfraction 10 (456 mg), eluted

with dichloromethane was fractionated into acidic and neutral fractions with aqueous NaOH 2M. The neutral fraction, washed with water and concentrated under vacuum (380 mg), was purified by FCC eluting with chloroform : ethanol (49:1) to give pure **38**. Subfraction *11* (587 mg), eluted with dichloromethane : acetone (9:1) was fractionated into acidic and neutral fractions with aqueous NaOH 2M. The neutral fraction (250 mg) was rechromatographed on FCC eluting with dichloromethane : acetone (9:1) to give pure **47**. Subfraction *13* (180 mg), eluted with dichloromethane : acetone (7:3), was fractionated into acidic and neutral fractions with aqueous NaOH 2M. The aqueous alkaline solution was cooled and acidified with HCl 4 M, and the liberated solids were extracted with ethyl acetate, washed with water, and concentrated under vacuum, yielding 110 mg of residual material. This was then purified by RP-18 HPLC with methanol : acetonitrile : water (4:1:5), to give pure **50** and **51**.

Fraction *4* (340 mg), eluted with dichloromethane : acetone (7:3), was rechromatographed on FCC.

Subfraction *5* (32 mg), eluted with dichloromethane : ethyl acetate (49:1), was purified by preparative TLC [dichloromethane : acetone (22:3), **41** and **21**]. Subfraction *9* (1.5 g), eluted with dichloromethane : acetone (7:3), was rechromatographed on FCC. The fraction eluted with dichloromethane : acetone (4:1) was purified by preparative TLC [dichloromethane : methanol (9:1)], to give pure **28** and **29**.

Fractions *5*, *6*, *7*, *8* and *9* were eluted with EtOAc-CH₂Cl₂- petrol ether gradient. Fraction *5* (1.0 g) contained **60**, which was purified using HPLC with MeOH-CH₃CN-H₂O (2:1:2), and **61** was purified on silica gel column [CHCl₃-acetone (9:1)]. Fraction *6* (1.2 g) contained **34**, which was purified using HPLC with MeOH-CH₃CN-H₂O (2:1:2). Fraction *7* (750 mg) contained **68**, which was purified by semipreparative TLC [CHCl₃-EtOAc (19:1)]. Fraction *8* (6.0 gr) was washed with 2N NaOH and the organic phase,

after neutralization, gave a crude residue (320 mg) which was repeatedly chromatographed on silica gel column acetone-CHCl₃-petrol ether gradient to afford a mixture of eight compounds. **71** was purified by semipreparative TLC [petrol ether-CHCl₃-acetone (8:11:1)]. **66** was purified by semipreparative TLC [petrol ether-acetone (4:1)]. **33** was purified using HPLC with MeOH-CH₃CN-H₂O (5:1:4). **72** and **70** were purified by semipreparative TLC [CHCl₃-acetone (4:1)]. **67**, **69** and **73** were separated using HPLC with MeOH-CH₃CN-H₂O (3:2:5). The aqueous alkaline solution was acidified in the cold with conc. HCl and liberated solids were extracted with EtOAc. The solution was washed with H₂O, dried and the solvent removed in vacuum. The crude residue (315 mg) was repeatedly chromatographed on silica gel column acetone-CH₂Cl₂ gradient to afford a mixture of four compounds. **62** and **16** were purified by HPLC with MeOH-H₂O (9:11). **64** was purified using HPLC with MeOH-CH₃CN-H₂O (2:1:2). **14** was purified by HPLC with MeOH-CH₃CN-H₂O (4:1:5). Fraction 9 (700 mg) contained **63** and **65**, that were purified using HPLC with MeOH-CH₃CN-H₂O (6:1:13).

The concentrated water layer (2.0 L) was chromatographed on Amberlite XAD-2 with water, methanol, and acetone. The methanol fraction was concentrated and suspended in water and extracted with chloroform (1.0 L). The organic layer (4.3 g) was chromatographed on FCC.

Fraction 2 (300 mg), eluted with *n*-hexane : chloroform : acetone (14:6:5), was rechromatographed on Sephadex LH-20 eluting with *n*-hexane : chloroform : methanol (3:1:1), to give three fractions. The 2nd (71 mg) was purified by preparative TLC [chloroform : acetone (17:3)] to give pure **37**.

Fraction 5 (240 mg), eluted with *n*-hexane : chloroform : acetone (7:3:10), was rechromatographed on Sephadex LH-20 eluting with *n*-hexane : chloroform : methanol

(1:3:1) to give three fractions. The 1st (60 mg) was purified by preparative TLC [dichloromethane : acetone (7:3)] to give pure **4**.

Fraction 7 (270 mg), eluted with dichloromethane : acetone (1:1), was rechromatographed on Sephadex LH-20 eluting with *n*-hexane : chloroform : methanol (3:1:1) to give four fractions. The 2nd (22 mg) was purified by RP-18 HPLC with methanol : acetonitrile : water (1:1:3) to give pure **49**.

Hydroalcoholic twig extract fractionation. An aqueous solution of the hydroalcoholic extract (200 g), after precipitation of proteinaceous material was extracted with dichloromethane (1.0 L). The organic phase was concentrated and subjected to FCC.

Fraction 1 (700 mg), eluted with chloroform, was rechromatographed on FCC. Subfraction 3, eluted with *n*-hexane : ethyl acetate (9:1), contained pure **44** and subfraction 6, eluted with *n*-hexane : ethyl acetate (3:1) contained pure **40**.

Fraction 6 (294 mg), eluted with chloroform : acetonitrile (17:3), was rechromatographed on FCC. Subfraction 4 (34 mg) was purified by preparative TLC [chloroform : ethanol (19:1)] and by RP-18 HPLC with methanol : acetonitrile : water (4:1:5) to give **46** and **48**.

Methanolic leaf extract fractionation. Cold acetone was added (1.0 l) to an aqueous suspension (700 ml) of the MeOH extract (150 g), and the mixture placed on a stir plate overnight in a cold room. The acetone addition produced heavy precipitation, consisting mostly of proteinaceous materials, which were removed by centrifugation. The acetone was removed by evaporation and the clear aqueous extract, reduced to 200 ml, was extracted with EtOAc. The organic layer was extracted with 2 N HCl and the organic phase was neutralized. After removal of the solvent, the crude residue (32 g) was chromatographed on silica gel column to give fractions A - Z.

Fraction P (455 mg) eluted with CHCl₃ - MeOH (9:1) was filtered on Sephadex LH-20 using hexane - CHCl₃ - MeOH (1:3:1) to give fractions 1-3. Fraction 1 (68 mg) consisted of a mixture of **55** and **58**, which were separated by TLC [CHCl₃ - acetone (22:3)].

Fraction 2 (132 mg), was rechromatographed on silica gel column. The fractions eluted with CHCl₃ - MeOH (95:5) gave the crude of **52**, **54** and **56**. Compound **54** was purified by preparative TLC [petrol - acetone (3:2)]. Compound **52** was purified by flash column chromatography [CHCl₃ - MeOH (9:1)]. Compound **56** was purified by reverse phase C-18 HPLC with MeOH - CH₃CN - H₂O (3:2:5). Fraction 3 (214 mg), was rechromatographed on silica gel column. The fraction eluted with CHCl₃ - acetone (17:3) consisted of a mixture of **53** and **57**, which was resolved by reverse phase C-18 HPLC with MeOH - CH₃CN - H₂O (3:2:5) to give pure **53** and pure **57**.

Methanolic root extract fractionation. Cold acetone was added (1.0 l) to an aqueous suspension (700 ml) of the MeOH extract (100 g), and the mixture placed on a stir plate overnight in a cold room. The acetone addition produces heavy precipitation consisting mostly of proteinaceous materials, which were removed by centrifugation. The acetone was removed by evaporation and the clear aqueous extract, reduced to 200 ml, was extracted with EtOAc. The organic layer was extracted with 2 N HCl and the organic phase was neutralized. After removal of the solvent, the crude residue (32 g) was chromatographed on silica gel column to give fractions A which was eluted with benzene/acetone 7:3 (86 mg). Fraction A was rechromatographed on silica gel column. The fractions eluted with CHCl₃ /EtOH 19:1 gave crude **59**, which was purified by reverse phase C-18 HPLC with MeOH/CH₃CN/H₂O 2:1:2 .

Bioassays. Pure Glyphosate was purchased from Sigma-Aldrich. Pendimethalin, bioassayed as commercial mixture (Pendulum®) supplied by Ingegnoli Spa (Milano, Italy).

Seed of *Lactuca sativa* L. (cv Cavolo di Napoli), *Lycopersicon esculentum* M. (cv Napoli V. F.), *Allium cepa* L. (cv Ramata di Milano) and *Lepidium sativum* L., collected during 2001, were obtained from Ingegnoli Spa. All undersized or damaged seeds were discarded and the assay seeds were selected for uniformity. For the bioassays we used Petri dishes in two sizes: 90 mm (tomato, cress and onion) and 50 mm (lettuce) diameter with one sheet of Whatman No. 1 filter paper as support. In four replicate experiments, germination and growth were conducted in aqueous solutions at controlled pH. Test solns. (10^{-4} M) were prepared using MES (2-[N-Morpholino]ethanesulfonic acid, 10 mM, pH 6) and the rest (10^{-5} – 10^{-9} M) were obtained by dilution. Parallel controls were performed. After adding 25 seeds and 5 mL test solutions for 90 mm dishes and 2.5 mL test solutions for 50 mm dishes, the Petri dishes were sealed with Parafilm to ensure closed-system models. Seeds were placed in a KBW Binder 240 growth chamber at 25 °C in the dark. Germination percentage was determined daily for 5 days for lettuce and tomato, 3 days for cress and for 7 days for onion (no more germination occurred after this time). After growth, the plants were frozen at –20 °C to avoid subsequent growth until the measurement process.

Data are reported as percentage differences from control in the graphics. Thus, zero represents the control; positive values represent stimulation of the parameter studied and negative values represent inhibition. Germination rate of the control solution: 75% onion, 90% tomato, 89% lettuce and 95% cress. Root length of the control: 2.4 cm onion, 3.8 tomato, 2.9 lettuce and 2.8 cress. Shoot length of the control: 4.5 cm onion, 2.7 tomato, 2.4 lettuce and 2.5 cress.

Spectroscopic data of isolated compounds

Compound 1. (-)-*Pinoresinol* (24 mg). $[\alpha]_D^{25} -10.0^\circ$ (c 9.0, CHCl₃). MS: m/z 358 [M]⁺. ¹H NMR (CDCl₃): δ 6.82 (6H, m, H-6 and H-6', H-5 and H-5', H-2 and H-2'), 4.74 (2H, d, J=4.0 Hz, H-7 and H-7'), 4.25 (2H, dd, J=9.0 and 7.0 Hz, H-9a and H-9'a), 3.88 (2H, dd, J=9.0 and 4.0 Hz, H-9b and H-9'b), 3.10 (2H, m, H-8 and H-8'), 3.91 (6H, s, 3-OMe and 3'-OMe). ¹³C NMR (MeOD): δ 146.7 (C-3 and C-3'), 145.2 (C-4 and C-4'), 132.9 (C-1 and C-1'), 118.9 (C-6 and C-6'), 114.3 (C-5 and C-5'), 108.6 (C-2 and C-2'), 85.8 (C-7 and 7'), 71.6 (C-9 and C-9'), 54.1 (C-8 and C-8'), 55.9 (3-OMe and 3'-OMe).

Compound 2. (-)-*Isolariciresinol* (37 mg). $[\alpha]_D^{25} -30.0^\circ$ (c 12.0, MeOH). ¹H NMR (MeOD): δ 6.74 (1H, d, J=8.1 Hz, H-5), 6.65 (1H, s, H-5'), 6.67 (1H, d, J=1.8 Hz, H-2), 6.62 (1H, dd, J=8.1 and 1.8 Hz, H-6), 6.19 (1H, s, H-2'), 3.82 (3H, m, H-9b, H-9'a, H-9'b), 3.83 (1H, d, J=10.0 Hz, H-7), 3.40 (1H, dd, J=11.0 and 3.0 Hz, H-9a), 2.77 (2H, d, J=7.2 Hz, H-7'), 2.00 (1H, m, H-8'), 1.74 (1H, tt, J=10.0 and 3.0 Hz, H-8), 3.76 (3H, s, 3-OMe), 3.80 (3H, s, 3'-OMe). ¹³C NMR (MeOD): δ 149.6 (C-3'), 147.7 (C-3), 146.5 (C-4'), 145.7 (C-4), 139.2 (C-6'), 134.7 (C-1), 129.6 (C-1'), 123.7 (C-6), 117.8 (C-5'), 116.5 (C-5), 114.3 (C-2), 112.9 (C-2'), 66.5 (C-9'), 62.8 (C-9), 56.8 (3-OMe and 3'-OMe), 48.6 (C-7), 48.5 (C-8), 40.5 (C-8'), 34.1 (C-7').

Compound 3. (+)-*Secoisolariciresinol* (8 mg). $[\alpha]_D^{25} +28.1^\circ$ (c 10.0, MeOH). MS: m/z 362 [M]⁺. ¹H NMR (MeOD): δ 6.65 (2H, d, J=8.0 Hz, H-5 and H-5'), 6.59 (2H, d, J=2.0 Hz, H-2 and H-2'), 6.54 (2H, dd, J=8.0 and 2.0 Hz, H-6' and H-6), 3.60 (4H, m, H-9'a and b, H-9a and b), 2.67 (2H, dd, J=14.0 and 5.0 Hz, H-7a and H-7'a), 2.56 (2H, dd, J=14.0 and 5.0 Hz, H-7b and H-7b'), 3.73 (6H, s, 3'-OMe and 3-OMe), 1.90 (2H, m, H-8 and H-8'). ¹³C NMR (MeOD): δ 149.3 (C-3 and C-3'), 145.9 (C-4 and C-4'), 134.1 (C-1 and C-1'), 123.2 (C-6 and C-6'), 116.3 (C-5 and C-5'), 113.9 (C-2 and C-2'), δ

62.6 (C-9 and C-9'), 56.7 (3-OMe and 3'-OMe), 44.6 (C-8 and C-8'), 36.0 (C-8 and C-8').

Compound 4. (\pm)-*Lariciresinol* (30 mg). $[\alpha]_D^{25} 0^\circ$ (*c* 1.0, MeOH). ^1H NMR (MeOD): δ 6.72 (1H, d, *J*=8.1 Hz, H-5'), 6.65 (1H, dd, *J*=8.1 and 1.8 Hz, H-6'), 6.78 (2H, m, H-5 and H-6), 6.90 (1H, bs, H-2'), 6.41 (1H, bs, H-2), 4.80 (1H, d, *J*=6.0 Hz, H-7'), 4.00 (1H, dd, *J*=8.1 and 6.0 Hz, H-9b), 3.74 (2H, m, H-9'a and H-9'b), 3.80 (1H, dd, *J*=8.1 and 6.0 Hz, H-9a), 3.82 (6H, s, 3'-OMe and 3-OMe), 2.87 (1H, dd, *J*=13.0 and 5.0 Hz, H-7a), 2.74 (1H, m, H-8), 2.45 (1H, dd, *J*=13.0 and 10.0 Hz, H-7b), 2.35 (1H, m, H-8'). ^{13}C NMR (MeOD): δ 146.9 (C-3' and C-3), 145.1 (C-4'), 143.9 (C-4), 118.1 (C-6'), 133.7 (C-1), 131.6 (C-1'), 120.5 (C-6), 114.4 (C-5'), 114.6 (C-5), 111.6 (C-2), 108.7 (C-2'), 59.1 (C-9'), 72.1 (C-9), 55.1 (3-OMe and 3'-OMe), 32.3 (C-7), 42.1 (C-8), 52.2 (C-8'), 82.3 (C-7').

Compound 5. (-)-*Tanegol* (11 mg). $[\alpha]_D^{25} -10.0^\circ$ (*c* 2.5, MeOH). MS: *m/z* 376 $[\text{M}]^+$. ^1H NMR (MeOD): δ 6.75 (1H, d, *J*=8.0 Hz, H-5), 6.73 (2H, m, H-5' and H-6'), 6.92 (1H, d, *J*=1.8 Hz, H-2), 6.79 (1H, dd, *J*=8.0 and 1.8 Hz, H-6), 6.87 (1H, s, H-2'), 4.62 (1H, d, *J*=7.0 Hz, H-7), 4.47 (1H, d, *J*=9.0 Hz, H-7'), 4.24 (1H, dd, *J*=9.0 and 4.0 Hz, H-9' β), 3.93 (1H, dd, *J*=7.0 and 9.0 Hz, H-9' α), 3.29 (1H, dd, *J*=11.0 and 4.0 Hz, H-9a), 2.51 (1H, m, H-8'), 1.87 (1H, m, H-8), 3.21 (1H, dd, *J*=11.0 and 6.0 Hz, H-9b), 3.82 (3H, s, 3'-OMe), 3.84 (3H, s, 3-OMe). ^{13}C NMR (MeOD): δ 147.8 (C-3'), 145.9 (C-3), 134.8 (C-4'), 137.5 (C-4), 119.6 (C-6'), 137.4 (C-1), 133.0 (C-1'), 119.6 (C-6), 114.7 (C-5'), δ 114.7 (C-5), 110.3 (C-2), 109.8 (C-2'), 83.8 (C-7), 75.4 (C-7'), 70.3 (C-9'), 61.1 (C-9), 55.2 (3-OMe and 3'-OMe), 52.3 (C-8'), 49.5 (C-8).

Compound 6. (\pm)-*Dehydrodiconiferyl alcohol* (35 mg). $[\alpha]_D^{25} 0^\circ$ (*c* 9.0, MeOH). MS: *m/z* 358 $[\text{M}]^+$. ^1H NMR (MeOD): δ 6.93 (2H, m, H-2' and H-6'), 6.82 (1H, dd, *J*=8.1 and 1.8 Hz, H-6), 6.79 (1H, d, *J*=1.8 Hz, H-2), 6.75 (1H, d, *J*=8.1 Hz, H-5), 6.55 (1H, d,

J=15.8 Hz, H-7'), 6.18 (1H, dt, J=15.8 and 6.0 Hz, H-8'), 5.58 (1H, d, J=7.2 Hz, H-7), 4.29 (2H, d, J=6.0 Hz, H-9'), 3.85 (6H, s, 3'-OMe and 3-OMe), 3.79 (2H, m, H-9), 3.50 (1H, m, H-8). ¹³C NMR (MeOD): δ 147.3 (C-3'), 149.3 (C-3), 141.4 (C-4'), 140.2 (C-4), 127.6 (C-7'), 126.5 (C-8'), 116.2 (C-6'), 132.4 (C-1), 127.2 (C-1'), 122.0 (C-6), 135.3 (C-5'), 116.8 (C-5), 115.3 (C-2), 109.6 (C-2'), 88.2 (C-7), 65.6 (C-9'), 63.2 (C-9), 56.3 (3-OMe and 3'-OMe), 50.4 (C-8).

Compound 7. (±)-*Threo-guaiacylglycerol-β-O-4'-coniferyl ether*. (11 mg). [α]_D²⁵ 0° (c 1.5, MeOH). MS: *m/z* 376 [M]⁺. ¹H NMR (MeOD): δ 7.00 (2H, m, H-5' and H-6'), 6.87 (2H, s, H-2 and H-2'), 6.83 (1H, dd, J=8.0 and 2.0 Hz, H-6), 6.72 (1H, d, J=8.0 Hz, H-5), 6.51 (1H, d, J=15.8 Hz, H-7'), 6.23 (1H, dt, J=15.8 and 5.8 Hz, H-8'), 4.83 (1H, d, J=6.0 Hz, H-7), 4.36 (1H, m, H-8), 4.20 (2H, d, J=6.0 Hz, H-9'a and b), 3.84 (1H, dd, J=11.8 and 5.8 Hz, H-9a), 3.76 (1H, dd, J=11.8 and 4.0 Hz, H-9b), 3.80 (3H, s, 3'-OMe, 3-OMe). ¹³C NMR (MeOD): δ 150.9 (C-3), 150.5 (C-3'), 146.0 (C-4'), 139.9 (C-4), 133.8 (C-7'), 133.0 (C-1'), 131.7 (C-1), δ 122.2 (C-8'), 119.8 (C-5) 119.5(C-6), 119.7 (C-6'), 118.8 (C-5'), 112.4 (C-2), 110.2 (C-2'), 80.0 (C-8), 73.8 (C-7), 65.0 (C-9'), 62.9 (C-9), 56.6 (3-OMe), 55.8 (3'-OMe).

Compound 8. (+)-*Threo-guaiacylglycerol-β-O-4'-sinapyl ether* (12 mg). [α]_D²⁵ +9.17° (c 2.5, MeOH). CD (EtOH): [θ]₂₃₄= -23100, [θ]₂₇₅= - 3300. MS: *m/z* 406 [M]⁺. ¹H NMR (CD₃OD): δ 6.99 (1H, d, J=2.0 Hz, H-2), 6.80 (1H, dd, J=8.0 and 2.0 Hz, H-6), 6.74 (1H, d, J=8.0 Hz, H-5), 6.73 (2H, s, H-6' and H-2'), 6.55 (1H, d, J=15.8 Hz, H-7'), 6.30 (1H, dt, J=15.8 and 5.8 Hz, H-8'), 4.92 (1H, d, J=5.1 Hz, H-7), 4.22 (3H, m, 2H-9' and H-8), 3.87 (1H, dd, J=11.0 and 7.0 Hz, H-9a), 3.84 (9H, s, 3'-OMe, 3-OMe and 5'-OMe), 3.55 (1H, dd, J=11.0, 4.0 Hz, H-9b). ¹³C NMR (MeOD): δ 154.9 (C-3' and C-5'), 148.9 (C-4'), 147.2 (C-3), 136.7 (C-4), 135.1 (C-1'), 134.1 (C-1), 131.7 (C-7'), 130.1 (C-

8'), 120.9 (C-6), 116.0 (C-5), 111.7 (C-2), 105.2 (C-2' and C-6'), 87.9 (C-8), 74.3 (C-7), 63.8 (C-9'), 61.7 (C-9), 56.0 (3-OMe), 56.2 (3'-OMe and 5'-OMe).

Compound 9. (\pm)-*Erythro-syringylglycerol- β -O-4-sinapyl ether* (3 mg). $[\alpha]_D^{25}$ 0° (c 2.0, MeOH). MS: m/z 436 [M]⁺. ¹H NMR (CD₃OD): δ 6.69 (2H, s, H-2 and H-6), 6.58 (2H, s, H-2' and H-6'), 6.57 (1H, d, J=15.8 Hz, H-7'), 6.36 (1H, dt, J=15.8, 5.8 Hz, H-8'), 4.99 (1H, d, J=4.0 Hz, H-7), 4.36 (2H, dd, J=5.8, 1.5 Hz, H-9'), 4.12 (1H, m, H-8), 3.92, 3.90, 3.89 and 3.88 (12H, s, 3'-OMe, 3-OMe, 5-OMe, 5'-OMe), 3.86 (1H, partially obscured, H-9a), 3.49 (1H, dd, J=12.0, 3.0 Hz, H-9b). ¹³C NMR (CD₃OD): δ 154.9 (C-3' and C-5'), 148.9 (C-4'), 147.2 (C-3 and C-5), 136.7 (C-4), 135.1 (C-1'), 134.1 (C-1), 130.2 (C-7'), 128.6 (C-8'), 103.1 (C-6), 102.1 (C-2), 98.3 (C-2' and C-6'), 86.9 (C-8), 72.3 (C-7), 55.9 (3-OMe and 5-OMe), 55.8 (3'-OMe and 5'-OMe), 63.1 (C-9'), 60.2 (C-9).

Compound 10. *1-Feruloyloxy-2-methoxy cinnamic acid* (15 mg). MS: m/z 370 [M]⁺. ¹H NMR (CD₃OD): δ 7.59 (1H, d, J=8.5 Hz, H-5), 7.57 (1H, d, J=15.5 Hz, H-7), 7.19 (1H, d, J=2.0 Hz, H-2), 6.81 (1H, dd, J=8.5 and 2.0 Hz, H-6), 6.36 (1H, d, J= 15.5 Hz, H-8), 3.80 (3H, s, 3-OMe).

Compound 11. (8 mg). $[\alpha]_D^{25}$ 0° (c 2.5, CHCl₃). MALDI-MS: m/z 833 [M+Na]⁺. ¹H NMR (CDCl₃): δ 6.97 (2H, d, J=2.0 Hz, H-2'' and H-2'''), 6.86 (2H, d, J=8.0 Hz, H-5'' and H-5'''), 6.74 (2H, dd, J=8.0, 2.0 Hz, H-6'' and H-6'''), 6.64 (4H, s, H-2, H-6, H-2' and H-6'), 5.00 (2H, d, J=4.0 Hz, H-7'' and H-7'''), 4.79 (2H, brs, H-7 and H-7'), 4.34 (2H, m, H-9a and H-9'a), 4.14 (2H, m, H-8'' and H-8'''), 3.98 (2H, dd, J=7.6, 2.2 Hz, H-9b and H-9'b), 3.92, 3.91 and 3.90 (18H, s, 3-OMe, 5-OMe, 3'-OMe, 5'-OMe, 3''-OMe and 3'''-OMe), 3.88 (2H, m, H-9''a and H-9'''a), 3.51 (2H, dd, J=10.0, 2.0 Hz, H-9''b and H-9'''b), 3.14 (2H, m, H-8 and H-8'). ¹³C NMR (CDCl₃): δ 153.5 (C-3, C-5, C-3' and C-5'), 146.6 (C-3'' and C-3'''), 144.8 (C-4'' and C-4'''), 137.6 (C-4 and C-4'), 134.3 (C-1 and C-

1'), 131.3 (C-1" and C-1'''), 118.7 (C-6" and C-6'''), 114.1 (C-5" and C-5'''), 108.3 (C-2" and C-2'''), 102.8 (C-2, C-6, C-2' and C-6'), 87.1 (C-8" and C-8'''), 85.8 (C-7 and C-7'), 72.5 (C-7" and C-7'''), 71.9 (C-9 and C-9'), 60.7 (C-9" and C-9'''), 56.2 and 56.0 (3-OMe, 5-OMe, 3'-OMe, 5'-OMe, 3"-OMe and 3'''-OMe), 54.4 (C-8 and C-8').

Compound 12. (\pm)-*Erythro-guaiacylglycerol- β -O-4'-dehydrodisinapyl ether* (10mg).

$[\alpha]_D^{25}$ 0° (c 2.5, CHCl₃). MS: *m/z* 584 [M]⁺. ¹H NMR (CDCl₃): δ 6.95 (1H, d, J=2.0 Hz, H-6), 6.90 (2H, s, H-2 and H-2''), 6.87 (1H, dd, J=8.0, 2.0 Hz, H-6''), 6.75 (1H, d, J=8.0 Hz, H-5''), 6.70 (2H, s, H-2' and H-6), 6.51 (1H, d, J=15.8 Hz, H-7), 6.25 (1H, dt, J=15.8, 5.8 Hz, H-8), 5.65 (1H, d, J=8.5 Hz, H-7'), 4.99 (1H, d, J=4.5 Hz, H-7''), 4.32 (2H, dd, J=5.8, 1.0 Hz, H-9), 4.10 (1H, m, H-8''), 4.00 (1H, m, H-9'a), 3.92 (5H, m, 3-Ome, H-9'a and H-9'b), 3.89 (3H, s, 3"-OMe), 3.85 (6H, s, 3'-OMe and 5'-OMe), 3.67 (1H, m, H-8'), 3.50 (1H, dd, J=11.0, 2.0 Hz, H-9''b). ¹³C NMR (CD₃OD): δ 153.7 (C-5'), 153.6 (C-3'), 148.4 (C-4), 146.8 (C-3''), 145.1 (C-4''), 144.7 (C-3), 137.9 (C-4'), 134.9 (C-1'), 131.5 (C-1''), 131.4 (C-1 and C-5), 127.9 (C-7), 126.9 (C-8), 118.9 (C-6 and C-6''), 114.9 (C-6), 114.4 (C-2' and C-6'), 110.7 (C-2), 108.6 (C-2''), 103.3 (C-5''), 88.3 (C-7'), 87.3 (C-8''), 72.7 (C-7''), 64.3 (C-9'), 63.9 (C-9), 60.7 (C-9''), 56.5 (3-OMe and 3"-OMe), 56.2 (3'-OMe and 5'-OMe), 53.8 (C-8').

Compound 13. (-)-*Threo-guaiacylglycerol- β -O-4-lariciresinol ether* (9 mg): $[\alpha]_D^{25}$ -

3.4° (c 2.0, MeOH). MALDI/MS: *m/z* 579 [M+Na]⁺. ¹H NMR (CD₃OD): δ 6.97 (1H, d, J=2.0 Hz, H-2''), 6.93 (1H, s, H-2'), 6.87 (1H, dd, J=8.0, 2.0 Hz, H-6''), 6.82 (2H, m, H-2 and H-6'), 6.80 (1H, d, J=8.0 Hz, H-5''), 6.76 (1H, d, J=8.0 Hz, H-5), 6.72 (1H, d, J=8.0 Hz, H-5'), 6.64 (1H, dd, J=8.0, 1.5 Hz, H-6), 4.77 (1H, d, J=6.0 Hz, H-7''), 4.69 (1H, d, J=6.5 Hz, H-7'), 4.27 (1H, m, H-8''), 3.93 (1H, dd, J=8.3 Hz, 6.4, H-9a), 3.84 (3H, s, 3'-OMe), 3.83 (1H, m, H-9'a), 3.80 (4H, s, 3"-OMe and H-9'a), 3.78 (3H, s, 3-OMe), 3.77 (1H, m, H-9''b), 3.72 (1H, dd, J=8.3, 5.8 Hz, H-9b), 3.61 (1H, dd, J=11.0,

6.4 Hz, H-9'b), 2.89 (1H, dd, J=12.5, 5.0 Hz, H-7a), 2.67 (1H, m, H-8), 2.46 (1H, dd, J=12.5, 11.5 Hz, H-7b), 2.33 (1H, m, H-8'). ¹³C NMR (CD₃OD): δ 152.1 (C-3), 149.1 (C-3'), 148.9 (C-3''), 147.7 (C-4), 147.3 (C-4''), 147.2 (C-4'), 136.8 (C-1), 135.8 (C-1'), 134.3 (C-1''), 122.5 (C-6), 121.2 (C-6''), 120.1 (C-6'), 119.8 (C-5'), 116.3 (C-5), 115.9 (C-5''), 114.5 (C-2), 112.0 (C-2''), 110.9 (C-2'), 86.7 (C-8''), 84.3 (C-7'), 74.4 (C-7''), 73.8 (C-9), 62.5 (C-9''), 60.7 (C-9'), 56.9 (3-OMe and 3''-OMe), 56.4 (3'-OMe), 54.2 (C-8'), 43.9 (C-8), 34.0 (C-7).

Compound 14. (6*R*,7*E*,9*S*)-9-Hydroxy-4,7-megastigmadien-3-one. (5 mg). [α]_D²⁵ +200° (c 2.0, CHCl₃). MS: *m/z* 208 [M]⁺. ¹H NMR (CDCl₃): δ 5.89 (1H, s, H-4), 5.67 (1H, dd, J=6.0 e 16.0 Hz, H-8), 5.53 (1H, dd, J=16.0 and 8.6 Hz, H-7), 4.35 (1H, m, H-9), 2.52 (1H, d, J=8.6 Hz, H-6), 2.34 (1H, d, J=17.0, H-2), 2.08 (1H, d, J=17.0 Hz, H-2), 1.90 (3H, s, H-13), 1.30 (3H, d, J=6.4 Hz, H-10), 1.03 (3H, s, H-11), 0.97 (3H, s, H-12). ¹³C NMR (CDCl₃): δ 199.0 (C-3), 161.7 (C-5), 138.5 (C-8), 126.6 (C-4), 125.7 (C-7), 68.2 (C-9), 55.3 (C-6), 47.4 (C-2), 36.0 (C-1), 27.7 (C-12), 26.9 (C-11), 23.5 (C-10), 23.4 (C-13).

Compound 15. (3*S*,4*R*,7*E*,9*S*)-3,4,9-Trihydroxy-5,7-megastigmadiene (7 mg). [α]_D²⁵ -40.9° (c 1.8, CH₃OH). MS: *m/z* 226 [M]⁺. ¹H NMR (CD₃OD): δ 6.03 (1H, d, J=16.0 Hz, H-7), 5.55 (1H, dd, J= 6.5 and 16.0 Hz, H-8), 4.30 (1H, quintuplet, J=6.5 Hz, H-9), 3.85 (1H, d, J=3.0 Hz, H-4), 3.75 (1H, dt, J=12.0 and 3.0 Hz, H-3), 1.84 (3H, s, H-13), 1.80 (1H, dd, J=12.5 and 12.0 Hz, H-2α), 1.43 (1H, dd, J=12.5 and 3.0 Hz, H-2β), 1.26 (3H, d, J=6.5 Hz, H-10), 1.06 (3H, s, H-12), 1.04 (3H, s, H-11). ¹³C NMR (MeOD): δ 142.9 (C-6), 141.0 (C-8), 129.4 (C-5), 127.3 (C-7), 73.1 (C-4), 69.8 (C-3), 69.9 (C-9), 42.1 (C-2), 38.2 (C-1), 30.8 (C-11), 28.2 (C-12), 24.3 (C-10), 20.3 (C-13).

R-MPTA derivatives of compound 15 (1 mg) . ¹H NMR (CDCl₃): δ 6.10 (1H. d, J=15.5 Hz, H-7), 5.45 (1H, dd, J= 6.0 and 15.5 Hz, H-8), 5.62(1H, quintuplet, J=6.0 Hz,

H-9), 4.06 (1H, d, J=3.1 Hz, H-4), 5.22 (1H, dt, J=12.0 and 3.0 Hz, H-3), 2.12 (1H, dd, J= 12.5 and 12.0 Hz, H-2 α), 1.62 (1H, dd, J=12.5 and 3.0 Hz, H-2 β), 1.46 (3H, d, J= 6.0 Hz, H-10), 1.00 (3H, s, H-11), 1.09 (3H, s, H-12), 1.75 (3H, s, H-13).

S-MPTA derivatives of compound 15 (1 mg). $^1\text{H NMR}$ (CDCl_3): δ 6.19 (1H, d, J=16.0 Hz, H-7), 5.54 (1H, dd, J= 6.5 and 16.0 Hz, H-8), 5.64 (1H, quintuplet, J=6.5 Hz, H-9), 4.17 (1H, d, J=4.1 Hz, H-4), 5.19 (1H, dt, J=12.0 and 3.9 Hz, H-3), 1.95 (1H, dd, J= 12.5 and 12.0 Hz, H-2 α), 1.59 (1H, dd, J=12.5 and 3.9 Hz, H-2 β), 1.42 (3H, d, J= 6.5 Hz, H-10), 1.00 (3H, s, H-11), 1.12 (3H, s, H-12), 1.81 (3H, s, H-13).

Compound 16. *Blumenol A* (4 mg). $[\alpha]_{\text{D}}^{25} +50.9^\circ$ (c 2.1, CHCl_3). CD (MeOH): $\Delta\epsilon_{241} = +9.3$, $\Delta\epsilon_{319} = -0.7$. MS: m/z 224 $[\text{M}]^+$. $^1\text{H NMR}$ (CDCl_3): δ 5.89 (1H, s, H-4), 5.78 (1H, d, J=15.0 Hz, H-7), 5.84 (1H, m, H-8), 4.41 (1H, m, H-9), 2.43 (1H, d, J=17.0 Hz, H-2 α), 2.24 (1H, d, J=17.0, H-2), 1.92 (3H, s, H-13), 1.30 (3H, d, J=6.5 Hz, H-10), 1.10 (3H, s, H-11), 1.03 (3H, s, H-12). $^{13}\text{C NMR}$ (CDCl_3): δ 199.0 (C-3), 161.7 (C-5), 131.5 (C-8), 126.6 (C-4), 131.7 (C-7), 70.2 (C-9), 78.9 (C-6), 49.6 (C-2), 41.2 (C-1), 22.8 (C-12), 24.6 (C-11), 20.5 (C-10), 18.9 (C-13).

Compound 17. *(3S,5R,6R,7E,9R)-5,6-Epoxy-3,9-dihydroxy-7-megastigmene* (2 mg) $[\alpha]_{\text{D}}^{25} 0$ (2.5, CHCl_3). $^1\text{H NMR}$ (CDCl_3): δ 5.90 (1H, d, J=16.5 Hz, H-7), 5.76 (1H, dd, J=16.5 and 6.5 Hz, H-8), 4.38 (1H, m, H-9), 3.89 (1H, m, H-3), 2.36 (1H, dd, J= 9.3 and 5.2 Hz, H-4 $_{\text{eq}}$), 1.60 (2H, m, H-2 $_{\text{ax}}$ and H-4 $_{\text{ax}}$), 1.37 (1H, dd, J=12.3 and 10.1, H-2 $_{\text{eq}}$), 1.28 (1H, d, J=6.5 Hz, H-10), 1.19 (3H, s, H-13), 1.12 (3H, s, H-11), 0.97 (3H, s, H-12). $^{13}\text{C NMR}$ (CDCl_3): δ 137.8 (C-8), 124.9 (C-7), 69.5 (C-6), 68.2 (C-9), 66.3 (C-5), 64.2 (C-3), 47.0 (C-4), 40.8 (C-2), 34.9 (C-1), 29.5 (C-11), 24.7 (C-12), 23.6 (C-10), 19.8 (C-13).

Compound 18. *Corchoinoside C* (3 mg). $[\alpha]_{\text{D}}^{25} 0^\circ$ (c 3.1, MeOH). MS: m/z 409 $[\text{M}]^+$. $^1\text{H NMR}$ (CD_3OD): δ 5.98 (1H, d, J=16.0 Hz, H-7), 5.86 (1H, br s, H-4), 5.75 (1H, dd,

J= 6.5 and 16.0 Hz, H-8), 4.54 (1H, m, H-9), 4.27 (1H, d, J=7.4 Hz, H-1'), 3.86 (1H, dd, J=12.0 and 2.1 Hz, H-6'), 3.66 (1H, dd, J=12.0 and 6.3 Hz, H-6'), 3.12-3.40 (4H, m, 2', 3', 4', H-5'), 2.63 (1H, d, J=17.0 Hz, H-2 β), 2.18 (1H, d, J=17.0 Hz, H-2 α), 1.95 (3H, s, H-13), 1.29 (3H, d, J= 6.5 Hz, H-10), 1.04 (3H, s, H-12), 1.02 (3H, s, H-11). ^{13}C NMR (CD_3OD): δ 201.3 (C-3), 167.1 (C-5), 134.2 (C-7), 134.0 (C-8), 127.3 (C-4), 101.6 (C-1'), 78.8 (C-5'), 78.6 (C-3'), 75.4 (C-2'), 75.0 (C-9), 72.1 (C-4'), 63.1 (C-6'), 50.9 (C-2), 42.5 (C-1), 22.0 (C-12), 24.7 (C-12), 23.3 (C-11), 20.1 (C-13).

Compound 19. *4-Hydroxybenzoic acid* (5 mg). EI-MS: m/z 138 $[\text{M}]^+$, 94 $[\text{M}-\text{CO}_2]^+$. IR ν_{max} 3280, 3000 and 1708 cm^{-1} . ^1H NMR (CD_3OD): δ 7.96 (2H, d, J = 8.4 Hz, H-2 and H-6), 6.94 (2H, d, J = 8.4 Hz, H-3 and H-5). ^{13}C NMR (CD_3OD): δ 123.2 (C-1), 131.5 (C-2 and C-6), 115.6 (C-3 and C-5), 162.5 (C-4), 172.0 (C-7).

Compound 20. *p-Methoxybenzoic acid* (3 mg). EI-MS: m/z 152 $[\text{M}]^+$, 108 $[\text{M}-\text{CO}_2]^+$. IR ν_{max} 3000 and 1710 cm^{-1} . ^1H NMR (CD_3OD): δ 7.85 (2H, d, J = 7.5 Hz, H-2 and H-6), 6.85 (2H, d, J = 7.5 Hz, H-3 and H-5), 3.86 (OCH_3). ^{13}C NMR (CD_3OD): δ 122.9 (C-1), 131.1 (C-2 and C-6), 114.0 (C-3 and C-5), 167.2 (C-4), 172.0 (C-7), 56.0 (OCH_3).

Compound 21. *4-Hydroxy-3-methoxybenzoic acid* (2 mg). MS: m/z 152 $[\text{M}]^+$. ^1H NMR (CD_3OD): δ 7.57 (1H, s, H-2), 7.45 (1H, d, J=8.0 Hz, H-6), 6.76 (2H, d, J=8.0 Hz, H-5), 3.88 (3H, s, 3-OMe).

Compound 22. *2-Hydroxy benzoic acid (salicylic acid)* (20 mg) EI-MS: m/z 138 $[\text{M}]^+$, 94 $[\text{M}-\text{CO}_2]^+$. IR ν_{max} 3300, 3000 and 1710 cm^{-1} . ^1H NMR (CD_3OD): δ 7.84 (1H, d, J=7.6 Hz, H-6), 7.32 (1H, dd, J=6.8 and 8.1 Hz, H-4), 6.82 (1H, d, J=8.1 Hz, H-3), 6.80 (1H, dd, J=6.8 and 7.6 Hz, H-5). ^{13}C NMR (CD_3OD): δ 117.8 (C-1), 118.3 (C-2), 115.6 (C-3), 135.1 (C-4), 121.0 (C-5), 131.5 (C-6), 172.8 (C-7).

Compound 23. *4-Hydroxy-2-methoxybenzoic acid* (2 mg). MS: m/z 152 $[M]^+$. ^1H NMR (CD_3OD): δ 7.57 (1H, d, $J=1.8$ Hz, H-3), 7.49 (1H, dd, $J=8.2$ and 1.8 Hz, H-5), 6.75 (1H, d, $J=8.2$, H-6), 3.89 (3H, s, 2-OMe).

Compound 24. *4-Hydroxybenzyl alcohol* (5 mg). EI-MS: m/z 124 $[M]^+$, 107 $[M-\text{OH}]^+$. IR ν_{max} 3300 cm^{-1} . ^1H NMR (CD_3OD): δ 7.11 (2H, d, $J=7.6$ Hz, H-2 and H-6), 6.69 (2H, d, $J=7.6$ Hz, H-3 and H-5), 4.86 (2H, s, H-7). ^{13}C NMR (CD_3OD): δ 133.5 (C-1), 128.7 (C-2 and C-6), 115.9 (C-3 and C-5), 156.2 (C-4), 68.5 (C-7).

Compound 25. *4-Hydroxy-dihydrocinnamic acid* (20 mg). ^1H NMR (CD_3OD): δ 7.08 (2H, d, $J=8.0$ Hz, H-2 and H-6), 6.77 (2H, d, $J=8.0$ Hz, H-3 and H-5), 3.11 (2H, t, $J=7.0$ Hz, H-8), 2.80 (2H, t, $J=7.0$ Hz, H-7). ^{13}C NMR (CD_3OD): δ 177.1 (C-9), 154.8 (C-4), 133.2 (C-1), 130.4 (C-2 and C-6), 116.0 (C-3 and C-5), 37.3 (C-8), 32.1 (C-7).

Compound 26. *4-Hydroxy-3-methoxy-dihydrocinnamic acid* (40 mg). ^1H NMR (CD_3OD): δ 6.79 (1H, d, $J=2$ Hz, H-2), 6.69 (1H, d, $J=7.5$ Hz, H-5), 6.64 (1H, dd, $J=7.5$ and 2.0 Hz, H-6), 2.82 (2H, t, $J=7.5$ Hz, H-8), 2.54 (2H, t, $J=7.5$ Hz, H-7). ^{13}C NMR: δ 178.9 (C-9), 146.4 (C-4), 144.0 (C-3), 132.1 (C-1), 120.8 (C-6), 114.4 (C-5), 110.9 (C-2), 36.0 (C-8), 30.3 (C-7).

Compound 27. *Tyrosol* (12 mg). ^1H NMR (CD_3OD): δ 7.02 (2H, d, $J=8.0$ Hz, H-2 and H-6), 6.89 (2H, d, $J=8.0$ Hz, H-3 and H-5), 3.67 (2H, t, $J=7.5$ Hz, H-8), 2.71 (2H, t, $J=7.5$ Hz, H-7).

Compound 28. *4-Hydroxy-cinnamic acid* (5 mg) ^1H NMR (CD_3OD): δ 7.60 (1H, d, $J=15.5$ Hz, H-7), 7.44 (2H, d, $J=8.0$ Hz, H-2 and H-6), 6.80 (2H, d, $J=8.0$ Hz, H-3 and H-5), 6.30 (1H, d, $J=15.5$ Hz, H-8).

Compound 29. *Ferulic acid* (5 mg). ^1H NMR (CD_3OD): δ 7.56 (1H, d, $J=15.5$ Hz, H-7), 7.17 (1H, d, $J=1.5$ Hz, H-2), 7.05 (1H, dd, $J=8.5$ and 1.5 Hz, H-6), 6.80 (1H, d, $J=8.5$ Hz, H-4), 6.18 (1 H, d, $J=15.5$ Hz, H-8), 3.88 (3H, s, 3-OMe).

Compound 30. *Linalool or (2E,6S)-2,6-dimethyl-2,7-octadien-1,6-diol* (20 mg). $[\alpha]_D^{25} +17.5^\circ$ (c 0.79, CH₃OH). EI-MS: m/z 170 [M]⁺, 152 [M-H₂O]⁺. IR ν_{\max} 3600 and 3420 cm⁻¹. ¹H NMR (CD₃OD): δ 5.92 (1H, dd, J =10.5 and 17.5 Hz, H-7), 5.42 (1H, t, J=7.0 Hz, H-3), 5.22 (1H, dd, J=1.5 and 17.5 Hz, H-8), 5.08 (1H, dd, J=1.5 and 10.5 Hz, H-8), 3.99 (2H, s, H-1), 2.10 (2H, m, H-4), 1.66 (3H, s, H-9), 1.55 (2H, m, H-5), 1.29 (3H, s, H-10). ¹³C NMR (CD₃OD): δ 68.3 (C-1), 134.9 (C-2), 125.7 (C-3), 22.4 (C-4), 41.8 (C-5), 73.3 (C-6), 144.9 (C-7), 111.8 (C-8), 13.7 (C-9), 27.6 (C-10).

Compound 31. *Linalool-1-oic acid or (2E,6S)-2,6-dimethyl-2,7-octadien-6-ol acid* (10 mg). $[\alpha]_D^{25} -12.5^\circ$ (c 0.50, CHCl₃). EI-MS: m/z 184 [M]⁺, 156 [M-C₂H₄]⁺, 144 [M-CO₂]⁺. IR ν_{\max} 3400, 3050 and 1680 cm⁻¹. ¹H NMR (CDCl₃) δ : 6.84 (1H, t, J=7.0 Hz, H-3), 5.86 (1H, dd, J=10.7 and 17.3 Hz, H-7), 5.20 (1H, dd, J=1.0 and 17.3 Hz, H-8a), 5.06 (1H, dd, J=1.0 and 10.7 Hz, H-8b), 2.20 (2H, t, J=6.8 Hz, H-4), 1.78 (3H, s, H-9), 1.62 (2H, t, J = 6.8 Hz, H-5), 1.28 (3H, s, H-10). ¹³C NMR (CDCl₃): δ 171.5 (C-1), 127.4 (C-2), 143.5 (C-3), 23.5 (C-4), 40.4 (C-5), 72.9 (C-6), 144.3 (C-7), 112.1 (C-8), 27.5 (C-9), 12.0 (C-10).

Compound 32. (5 mg): $[\alpha]_D^{25} -2.0^\circ$ (c 5.0 CHCl₃). MS: m/z 262 [M]⁺. IR ν_{\max} 3300 and 1600 cm⁻¹. ¹H NMR (CDCl₃): δ 6.69 (1H, s, H-5), 4.00 (1H, dd, J=8.3 and 2.4 Hz, H-14), 3.45 (2H, m, H-10 and H-14), 3.81 (3H, s, -OMe), 2.43 (1H, q, J=6.8 Hz, H-11), 2.32 (1H, s, H-15), 2.12 (1H, m, H-8), 1.97 (1H, m, H-9), 1.49 (1H, m, H-9), 1.30 (1H, m, H-8), 1.14 (1H, d, J=6.8 Hz, H-12), 1.13 (1H, d, J=6.8 Hz, H-13), ¹³C NMR (CDCl₃): δ 144.0 (C-3), 142.9 (C-2), 139.5 (C-6), 127.0 (C-4), 125.1 (C-1), 115.8 (C-5), 74.7 (C-7), 67.9 (C-14), 60.7 (-OMe), 31.2 (C-11), 27.8 (C-10), 27.3 (C-8), 23.6 (C-9), 18.5 (C-12), 17.8 (C-13), 16.1 (C-15).

Compound 33. *(+)-Dehydrovomifoliol* (14 mg). $[\alpha]_D^{25} +260.0^\circ$ (c 0.30, CHCl₃). ¹H NMR (CDCl₃): δ 6.83 (1H, d, J=15.5 Hz, H-7), 6.46 (1H, d, J=15.5 Hz, H-8), 5.93 (1H,

s, H-4), 2.58 and 2.27 (1H, d, J=17.4 Hz, H-2), 2.29 (1H, s, H-10), 1.88 (3H, s, H-13), 1.09 (3H, s, H-11), 1.01 (3H, s, H-12).

Compound 34. (3*R*,7*E*)-3-Hydroxy-5,7-megastigmadien-9-one (19mg). $[\alpha]_D^{25} +19.0^\circ$ (c 0.080, CHCl₃). EIMS *m/z* 208 [M]⁺ (20), 193 [M-Me]⁺ (100); 175 [M-Me-H₂O]⁺ (50). ¹H NMR (CDCl₃): δ 1.09 (3H, s, H-11), 1.11 (3H, s, H-12), 1.78 (3H, s, H-13), 1.49 (1H, t, J=12.0 Hz, H-2_{ax}), 1.80 (1H, ddd, J=12.0 and 3.9, 2.0 Hz, H-2_{eq}), 2.08 (1H, dd, J=16.4 and 10.0 Hz, H-4_{ax}), 2.30 (3H, s, H-10), 2.44 (2H, dd, J=16.4 and 8.0 Hz, H-4_{eq}), 4.05 (1H, m, H-3), 6.14 (1H, d, J=16.3 Hz, H-8), 7.20 (1H, d, J=16.3 Hz, H-7). ¹³C NMR (CDCl₃): δ 198.4 (C-9), 142.2 (C-7), 135.5 (C-6), 132.2 (C-8), 132.0 (C-5), 64.3 (C-3), 48.2 (C-2), 42.6 (C-4), 36.7 (C-1), 29.9 (C-11), 28.4 (C-12), 21.4 (C-13), 27.2 (C-10).

Compound 35. (3*S*,5*R*,6*R*,7*E*,9*R*)-3,5,6,9-Tetrahydroxy-7-megastigmene (5 mg). $[\alpha]_D^{25} 0^\circ$ (2.0, CHCl₃). ¹H NMR (CDCl₃): δ 5.90 (1H, dd, J= 15.5 and 1.5 Hz, H-7), 5.66 (1H, dd, J=15.5 and 6.0 Hz, H-8), 4.28 (1H, m, H-9), 3.74 (1H, m, H-3), 2.27 (1H, dd, J= 9.3 and 5.0 Hz, H-4_{eq}), 1.62 (1H, dd, J=11.5 and 9.3 Hz, H-4_{ax}), 1.59 (1H, dd, J= 11.4 and 4.2 Hz, H-2_{eq}), 1.30 (1H, m, H-2_{ax}), 1.22 (1H, d, J= 6.5 Hz, H-10), 1.18 (3H, s, H-13), 1.12 (3H, s, H-11), 0.96 (3H, s, H-12). ¹³C NMR (CDCl₃): δ 139.6 (C-7), 126.4 (C-8), 71.6 (C-6), 69.1 (C-9), 68.5 (C-5), 65.0 (C-3), 48.5 (C-4), 42.1 (C-2), 36.4 (C-1), 30.5 (C-11), 25.4 (C-12), 24.3 (C-10), 20.6 (C-13).

Compound 36. (2 mg). $[\alpha]_D^{25} +21.0^\circ$ (c 0.005, CH₃OH). MS: *m/z* 340 [M]⁺. ¹H NMR (CD₃OD): δ 5.94 (1H, dd, J= 17.0 and 10.5 Hz H-2), 5.34 (1H, brt, J=7.0 H-6), δ 5.19 (1H, dd, J=17.0 and 1.5 Hz, H-1), 5.16 (1H, brt, J=7.0, H-10), 5.03 (1H, dd, J=10.5 and 1.5 Hz, H-1), 3.93 (1H, t, J=6.8 Hz, H-8), 3.23 (1H, dd, J=2.0 and 10.4 Hz, H-14), 2.24 (2H, m, H-9, H-12), 2.08 (2H, ddd, J=8.0, 7.6 and 7.0 Hz, H-5), 2.05 (1H, m, H-12), 1.70 (1H, m, H-13), 1.63 (1H, s, H-18), 1.60 (1H, s, H-19), 1.52 (1H, dd, J=8.0 and 7.6

Hz H-4), 1.34(1H, m, H-13), 1.25 (1H, s, H-20), 1.16(1H, s, H-16), 1.15 (1H, s, H-17),
 ^{13}C NMR (CD_3OH): δ 146.7 (C-2), 138.4 (C-7), 138.2 (C-11), 127.9 (C-6), 122.4 (C-10), 112.6 (C-1), 79.5 (C-14), 79.2 (C-8), 74.3 (C-3 and C-15), 43.5 (C-4), 38.5 (C-12), 35.2 (C-9), 31.2 (C-13), 28.1 (C-20), 26.1 (C-17), 25.5 (C-16), 23.8 (C-5), 16.9 (C-18), 11.9 (C-19).

Compound 37. *Cinnamic acid*. (40 mg) ^1H NMR (CDCl_3): δ 7.61 (1H, d, $J=15.5$ Hz, H-7), 7.30 (2H, d, $J=7.6$ Hz, H-2 and H-6), 7.21 (2H, dd, $J=7.6$ and 2.0 Hz, H-3 and H-5), 7.14 (1H, t, $J=7.6$ Hz, H-4), 6.41 (1H, d, $J=15.5$ Hz, H-8). ^{13}C NMR (CDCl_3): δ 170.6 (C-9), 148.3 (C-7), 128.7 (C-3 and C-5), 128.0 (C-4), 126.4 (C-2 and C-6), 115.6 (C-8).

Compound 38. *4-Hydroxy-3-methoxy-methyl cinnamate* (36 mg). MS: m/z 208 $[\text{M}]^+$, m/z 177 $[\text{M}-31]^+$. ^1H NMR (CDCl_3): δ 7.62 (1H, d, $J=16.0$ Hz, H-7), 7.07 (1H, dd, $J=8.2$ and 1.8 Hz, H-6), 7.02 (1H, d, $J=1.8$ Hz, H-2), 6.91 (1H, d, $J=8.2$ Hz, H-5), 6.29 (1H, d, $J=16.0$ Hz, H-8), 3.92 (3H, s, 3-OMe), 3.72 (3H, s, 9-OMe).

Compound 39. *4-Hydroxy-3,5-dimethoxy cinnamic acid* (17 mg). MS: m/z 238 $[\text{M}]^+$. ^1H NMR (CDCl_3): δ 6.75 (2H, s, H-2 and H-6), 7.58 (1H, d, $J=15.8$ Hz, H-7), 6.28 (1H, d, $J=15.8$ Hz, H-8), 3.89 (6H, s, 3-OMe and 5-OMe).

Compound 40. *4-Hydroxy-3-methoxy methyl dihydrocinnamate* (5 mg). MS: m/z 210 $[\text{M}]^+$. ^1H NMR (CDCl_3): δ 6.79 (1H, dd, $J=8.0$ and 2.0 Hz, H-6), 6.64 (1H, d, $J=8.0$ Hz, H-5), 6.70 (1H, d, $J=2.0$ Hz, H-2), 2.88 (2H, t, $J=8.4$ Hz, H-8), 2.59 (2H, t, $J=8.4$ Hz, H-7), 3.88 (3H, s, 3-OMe), 3.80 (3H, s, 9-OMe).

Compound 41. *4-(1-Hydroxyethyl)-2-methoxyphenol* (4 mg). $[\alpha]_{\text{D}}^{25}$ 0° (4.2, CHCl_3). MS: m/z 168 $[\text{M}]^+$. ^1H NMR (CDCl_3): δ 6.58 (1H, dd, $J=8.0$ and 20 Hz, H-6), δ 6.55 (1H, d, $J=8.0$ Hz, H-5), δ 6.53 (1H, d, $J=2.0$ Hz, H-2), δ 4.68 (1H, q, $J=6.5$, H-7), δ 3.73 (3H, s, 3-OMe), δ 1.49 (3H, d, $J=6.5$ Hz, H-8). ^{13}C NMR: δ 151.6 (C-3), 144.6 (C-

4), 134.3 (C-1), 120.9 (C-6), 117.1 (C-5), 112.6 (C-2), 76.0 (C-7), 56.2 (3-OMe), 22.9 (C-8).

Compound 42. *2-(4-Hydroxy-3-methoxyphenyl)-ethanol*. (5 mg) MS: m/z 168 $[M]^+$. 1H NMR ($CDCl_3$): δ 7.56 (1H, dd, $J=8.0$ and 2.0 Hz, H-6), δ 6.86 (1H, d, $J=8.0$ Hz, H-5), δ 7.53 (1H, d, $J=2.0$ Hz, H-2), δ 4.00 (2H, t, $J=6.0$, H-8), δ 3.18 (2H, t, $J=6.0$ Hz, H-7), δ 3.95 (3H, s, 3-OMe).

Compound 43. *4-Hydroxy-3-methoxy-benzylic alcohol*. (5 mg). MS: m/z 154 $[M]^+$. 1H NMR ($CDCl_3$): δ 6.90 (1H, d, $J=7.6$ Hz, H-5), 6.88 (1H, d, $J=2.0$ Hz, H-2), 6.84 (1H, dd, $J=7.6$ and 2.0 Hz, H-6), 4.60 (2H, s, H-7), 3.90 (3H, s, 3-OMe). ^{13}C NMR ($CDCl_3$): δ 146.7 (C-3), 145.3 (C-4), 132.9 (C-1), 120.2 (C-6), 114.2 (C-2), 109.9 (C-5), 95.4 (C-7).

Compound 44. *p-Hydroxystyrene* (36 mg). MS: m/z 120 $[M]^+$. 1H NMR ($CDCl_3$): δ 7.29 (2H, d, $J=8.0$ Hz, H-2 and H-6), δ 6.78 (2H, d, $J=8.0$ Hz, H-3 and H-5), δ 6.64 (1H, dd, $J=17.6$ and 10.8 Hz, H-7), δ 5.59 (1H, d, $J=17.6$ Hz, H-8a), δ 5.12 (1H, d, $J=10.8$ Hz, H-8b).

Compound 45. *4-Methylbenzaldehyde*. (60 mg). MS: m/z 108 $[M]^+$. 1H NMR ($CDCl_3$): δ 9.95 (1H, s, H-1), 7.77 (2H, d, $J=8.1$ Hz, H-2 and H-6), 7.32 (2H, d, $J=8.1$ Hz, H-3 and H-5), 2.43 (3H, s, 4-Me).

Compound 46. *Acetyl tryptamine* (30 mg). 1H NMR ($CDCl_3$): δ 7.61 (1H, d, $J=8.0$ Hz, H-7), 7.39 (1H, d, $J=8.0$ Hz, H-4), 7.22 (1H, t, $J=8.0$ Hz, H-5), 7.14 (1H, t, $J=8.0$ Hz, H-6), 3.61 (2H, dd, $J=17.5$ and 6.0 Hz, H-9), 2.98 (2H, t, $J=6.0$ Hz, H-8), 1.29 (3H, s, $COCH_3$). ^{13}C NMR δ 170.7 (C=O), 137.1 (C-1a), 128.0 (C-3a), 122.9 (C-6), 122.7 (C-2), 120.2 (C-5), 119.4 (C-4), 113.7 (C-3), 112.0 (C-7), 40.4 (C-9), 26.0 (C-8), 24.0 (CH_3).

Compound 47. (\pm)-*Syringaresinol* (52 mg). $[\alpha]_D^{25}$ 0° (c 3.5, CHCl_3). MS: m/z 418 $[\text{M}]^+$. ^1H NMR (CDCl_3): δ 6.57 (4H, s, H-2, H-5, H-2' and H-5'), 4.72 (2H, d, $J=4\text{Hz}$, H-7 and H-7'), 4.26 (2H, m, H-9_{exo} and H-9'_{exo}), 3.61 (2H, m, H-9_{endo} and H-9'_{endo}), 3.09 (2H, m, H-8 and H-8'), 3.89 (12H, s, 3-OMe, 3'-OMe, 5-OMe, 5'-OMe).

Compound 48. (\pm)-*5,5'-Dimethoxyariciresinol* (2 mg) $[\alpha]_D^{25}$ 0° (c 4.0, MeOH). ^1H NMR (CD_3OD): δ 6.59 (2H, s, H-2' and H-6'), 6.43 (2H, s, H-2 and H-6), 4.80 (1H, d, $J=6.0\text{ Hz}$, H-7'a), 4.06 and 3.85 (2H, dd, $J=8.1$ and 6.0 Hz , H-9'), 3.90 (12H, s, 3-OMe, 3'-OMe, 5-OMe, 5'-OMe), 3.80 (2H, m, H-9'), 2.93 (1H, dd, $J=13.0$ and 5.0 Hz , H-7'b), 2.73 (1H, m, H-8'), 2.54 (1H, dd, $J=13.0$ and 10.0 , H-7'), 2.43 (1H, m, H-8). ^{13}C NMR (CD_3OH): δ 147.0 (C-3 and 5), 146.9 (C-3' and 5'), 145.1 (C-4'), 143.9 (C-4), 133.7 (C-1), 131.6 (C-1'), 120.5 (C-2 and 6), 118.1 (C-2' and 6'), 82.7 (C-7'), 72.1 (C-9), 59.1 (C-9'), 54.1 (3 and 5-OMe), 54.0 (3' and 5'-OMe), 52.2 (C-8'), 42.1 (C-8), 32.3 (C-7).

Compound 49. (3mg). $[\alpha]_D^{25}$ $+4.0^\circ$ (c 0.12, CHCl_3). ESIMS (m/z) 615 $[\text{M}+\text{H}]^+$. UV λ_{max} (CHCl_3) nm (log ϵ): 256 (3.92), 220 (4.49). CD (CHCl_3) $[\theta]_{220}$ $+67000$, $[\theta]_{257}$ $+16600$. ^1H NMR (CDCl_3): δ 6.98 (1H, d, $J=1.5\text{ Hz}$, H-2''), 6.86 (1H, d, $J=7.6\text{ Hz}$, H-5''), 6.75 (1H, dd, $J=1.5$ and 7.6 Hz , H-6''), 6.65 (2H, s, H-2' and H-6'), 6.60 (2H, s, H-2 and H-6), 5.01 (1H, d, $J=6.9\text{ Hz}$, H-7''), 4.77 (2H, m, H-7 and H-7'), 4.32 (2H, m, H-9), 4.13 (1H, m, H-8''), 3.96 (2H, m, H-9'), 3.92 (15H, s, MeO-3, MeO-5, MeO-3', MeO-5', and MeO-3''), 3.88 (1H, m, H-9''a), 3.50 (1H, m, H-9''b), 3.12 (2H, m, H-8 and H-8'). ^{13}C NMR (CDCl_3): δ 153.6 (C-3, C-5, C-3', C-5'), 146.7 (C-3''), 145.1 (C-4''), 134.8 (C-4), 137.7 (C-4'), 132.1 (C-1'), 131.6 (C-1, C-1''), 118.9 (C-6''), 114.3 (C-5''), 108.8 (C-2''), 103.3 (C-2, C-6, C-2', C-6'), 89.2 (C-8''), 86.6 (C-7'), 84.9 (C-7), 72.8 (C-7''), 72.1 (C-9', C-9), 60.7 (C-9''), 56.4 (MeO-7'', MeO-3, MeO-5, MeO-3'', MeO-3', MeO-5'), 54.5 (C-8', C-8).

Compound 50. (3mg). $[\alpha]_D^{25} +13.0^\circ$ (CHCl₃, c 0.07). ESIMS (*m/z*) 629 [M+H]⁺. UV λ_{max} (CHCl₃) nm (log ϵ): 257 (3.90), 220 (4.52). CD (CHCl₃) $[\theta]_{220} +89600$, $[\theta]_{257} +11300$. ¹H NMR [(CD₃)₂CO]: δ 6.98 (1H, d, J = 1.5 Hz, H-2''), 6.81 (1H, d, J= 7.5 Hz, H-5'') 6.84 (1H, dd, J= 1.5 and 7.5 Hz, H-6''), 6.70 (2H, s, H-2,H-6), 6.68 (2H, s, H-2', H-6'), 4.71 (1H, d, J= 3.9 Hz, H-7'), 4.67 (1H, d,J= 3.9 Hz, H-7)4.56 (1H, d, J= 6.8 Hz, H7''), 4.24 (2H, dd, J= 7.1 and 15.0, H-9', H-9), 4.13 (1H, m,H-8''), 3.90 (2H, obscured, H-9, H-9'), 3.86 (3H, s, MeO-3''), 3.84 (6H, s, MeO-3', 5'), 3.82 (6H, s, MeO-3, 5) 3.80 (1H, obscured, H-9''), 3.52 (1H, dd , J=2.9 and 11.7 Hz, H-9''), 3.22 (3H, s, MeO-7''), 3.09 (2H, m, H-8', H-8), ¹³C NMR [(CD₃)₂CO]: δ 152.8 (C-3, C-5), 152.0 (C-3', C-5'), 146.9 (C-4''), 148.5 (C-3''), 148.3 (C-4) , 136.7 (C-4'), 134.3 (C-1'), 134.1 (C-1), 129.5 (C-1''), 121.7 (C-6''), 115.1 (C-5''), 111.9 (C-2''), 104.5 (C-2, C-6), 104.2 (C-2', C-6'), 86.8 (C-7), 86.6 (C-7'), 86.5 (C-8''), 83.5 (C-7''), 72.3 (C-9', C-9), 60.6 (C-9''), 58.1 (MeO-7''), 57.4 (MeO-3, 5), 57.0 (MeO-3''), 56.8 (MeO-3', 5'), 55.4 (C-8'), 55.2 (C-8).

Compound 51. (5mg). $[\alpha]_D^{25} +18.0^\circ$ (c 0.04, CHCl₃). ESI MS (*m/z*) 659 [M+H]⁺. UV λ_{max} (CHCl₃) nm (log ϵ): 265 (3.00), 226 (4.60). CD (CHCl₃) $[\theta]_{225} +9590$, $[\theta]_{267} +12500$. ¹H NMR (CD₃OD): δ 6.66 (2H, s, H-2' and H-6'), 6.62 (2H, s, H-2 and H-6), 6.58 (2H, s, H-2'' and H-6''), 4.73 (2H, d, J=3.8 Hz, H-7' and H-7), 4.60 (2H, dd, J=7.0 and 14.8 Hz, H-9 and H-9'), 4.43 (1H, d, J=6.7 Hz, H-7''), 4.22 (1H, m,H-8''), 3.90 (3H, obscured, H-9, H-9' and H-9''), 3.84 (6H, s, MeO-3'' and MeO-5''), 3.81 (6H, s, MeO-3' and MeO-5'), 3.80 (6H, s, MeO-3, 5), 3.77 (3H, s, MeO-7''), 3.70 (1H, dd, J=2.0 and 11.0 Hz, H-9''), 3.13 (2H, m, H-8, H-8'). ¹³C NMR (CD₃OD): δ 154.2 (C-3 and C-5), 154.0 (C-3' and C-5'), 150.2 (C-3'' and C-5''), 148.9 (C-4), 146.0 (C-4''), 138.2 (C-4'), 136.0 (C-1), 135.0 (C-1'), 131.1 (C-1''), 106.6 (C-2'' and C-6''), 105.0 (C-2' and C-6'), 104.7 (C-2 and C-6), 88.1 (C-7'), 87.7 (C-7), 86.7 (C-8''), 84.5 (C-7''), 73.4 (C-9 and C-

9'), 62.4 (C-9''), 58.2 (MeO-7''), 58.0 (MeO-3'' and MeO-5''), 57.3 (MeO-3 and MeO-5), 57.1 (MeO-3' and MeO-5'), 56.2 (C-8 and C-8').

Compound 52. *N-trans-feruloyl 4'-O-methyldopamine* (12 mg). ^1H NMR (CD_3OD): δ 7.50 (1H, d, $J=15.6$ Hz, H-7), 6.95 (1H, s, H-2), 7.00 (1H, dd, $J=8.1$ and 2.1 Hz, H-6), 6.80 (1H, s, H-2'), 6.88 (1H, d, $J=8.1$ Hz, H-5), 6.79 (1H, d, $J=8.1$ Hz, H-5'), 6.68 (1H, dd, $J=8.1$ and 2.0 Hz, H-6'), 6.19 (1H, d, $J=15.6$, H-8), 3.85 (6H, s, 4'-OMe and 3-OMe), 3.59 (2H, t, $J=7.1$, H-8'), 2.76 (2H, t, $J=7.1$, H-7'). ^{13}C NMR (CD_3OD): δ 166.4 (C-9), 145.7 (C-4'), 146.8 (C-3), 145.7 (C-4'), 145.4 (C-4), 141.1 (C-7), 132.1 (C-1'), 127.3 (C-1), 122.1 (C-6), 120.2 (C-6'), 118.2 (C-8), 115.0 (C-2'), 114.8 (C-5), 110.9 (C-5'), 109.7 (C-2), 55.9 (3-OMe), 56.0 (4'-OMe), 40.8 (C-8'), 34.9 (C-7').

Compound 53. *N-trans-feruloyl 3'-O-methyldopamine* (5 mg). MS: m/z 343 $[\text{M}]^+$. ^1H NMR (CD_3OD): δ 7.44 (1H, d, $J=15.8$ Hz, H-7), 7.21 (1H, d, $J=1.8$ Hz, H-2), 7.03 (1H, dd, $J=7.7$ and 1.8 Hz, H-6), 6.82 (1H, d, $J=1.8$ Hz, H-2'), 6.80 (1H, d, $J=7.7$ Hz, H-5), 6.73 (1H, d, $J=8.2$ Hz, H-5'), 6.67 (1H, dd, $J=8.2$, 1.8 Hz, H-6'), 6.41 (1H, d, $J=15.8$ Hz, H-8), 3.90 (3H, s, 3-OMe), 3.82 (3H, s, 4'-OMe), 3.49 (2H, t, $J=7.1$ Hz, H-8'), 2.77 (2H, t, $J=7.1$, H-7'). ^{13}C NMR (CD_3OD): 169.2 (C-9), 149.9 (C-3), 149.3 (C-3'), 149.0 (C-4), 146.1 (C-4'), 142.0 (C-7), 132.1 (C-1'), 128.3 (C-1), 123.2 (C-6), 122.3 (C-6'), 118.8 (C-8), 116.5 (C-5), 116.2 (C-5'), 113.5 (C-2'), 111.6 (C-2), 56.4 (3-OMe, 3'OMe), 42.5 (C-8'), 36.2 (C-7').

Compound 54. *N-trans-feruloyl tyramine* (10 mg). MS: m/z 313 $[\text{M}]^+$. ^1H NMR (MeOD): δ 7.45 (1H, d, $J=15.2$, H-7), 7.13 (1H, s, H-2), 7.06 (2H, d, $J=8.0$ Hz, H-2', H-6'), 7.01 (1H, dd, $J=8.4$ and 1.0 Hz, H-6), 6.79 (1H, d, $J=8.0$ Hz, H-5), 6.74 (2H, d, $J=8.0$ Hz, H-3' and H-5'), 6.42 (1H, d, $J=15.2$ Hz, H-8), 3.89 (3H, s, 3-OMe), 3.48 (1H, t, $J=8.0$ Hz, H-8'), 2.77 (1H, t, $J=8.0$ Hz, H-7'). ^{13}C NMR (CD_3OD): 168.7 (C-9), 156.4 (C-4'), 149.3 (C-3), 148.7 (C-4), 141.6 (C-7), 130.8 (C-1'), 130.3 (C-2', C-6'), 127.8

(C-6), 122.7 (C-1), 118.2 (C-8), 116.1 (C-5), 115.8 (C-3' and C-5'), 111.0 (C-2), 55.9 (3-OMe), 42.1 (C-8'), 35.9 (C-7').

Compound 55. *N-trans-4-O-methylferuloyl 3',4'-O-dimethyldopamine* (20 mg). MS: m/z 371 [M]⁺. ¹H NMR (CDCl₃): δ 7.56 (1H, d, J=15.2, H-7), 7.00 (1H, s, H-2), 6.76 (1H, dd, J=8.0 and 2.0 Hz, H-6'), 6.75 (1H, s, H-2'), 7.06 (1H, dd, J=8.4 and 1.0 Hz, H-6), 6.82 (1H, dd, J=8.0 and 2.0 Hz, H-5), 6.84 (1H, d, J=8.0 Hz, H-5'), 6.19 (1H, d, J=15.2 Hz, H-8), 3.89 (6H, s, 3-OMe and 3'-OMe), 3.87 (6H, s, 4-OMe and 4'-OMe), 3.65 (2H, d, J=8.0 Hz, H-8'), 2.82 (1H, t, J=8.0 Hz, H-7'). ¹³C NMR (CDCl₃): δ 166.1 (C-9), 150.5 (C-4), 149.1 (C-3 and C-3'), 147.7 (C-4'), 140.9 (C-7), 131.4 (C-1'), 127.7 (C-1), 121.9 (C-6), 120.6 (C-6'), 118.4 (C-8), 111.9 (C-2'), 111.3 (C-5'), 111.0 (C-5), 109.5 (C-2), 55.9 (3-OMe, 4-OMe, 3'-OMe and 4'-OMe), 40.8 (C-8'), 35.1 (C-7').

Compound 56. *N-trans-4-O-methylcaffeoyl 3'-O-methyldopamine* (7 mg). MS: m/z 337 [M]⁺. ¹H NMR (CD₃OD): □ 7.45 (1H, d, J=15.5 Hz, H-7), 7.13 (1H, d, J=1.6 Hz, H-2'), 7.04 (1H, dd, J=8.0, 1.6 Hz, H-6'), 6.95 (1H, d, J=2.0 Hz, H-2), 6.85 (1H, d, J=8.0 Hz, H-5), 6.81 (1H, d, J=8.0 Hz, H-5'), 6.69 (1H, dd, J=8.0 and 2.0 Hz, H-6), 6.42 (1H, d, J=15.5 Hz, H-8), 3.89 (3H, s, 4'-OMe), 3.83 (3H, s, 3-OMe), 3.48 (2H, t, J=7.6 Hz, H-8'), 2.76 (2H, t, J=7.6, H-7'). ¹³C NMR (CD₃OD): δ 169.2 (C-9), 149.9 (C-3), 149.3 (C-3'), 147.6 (C-4), 147.5 (C-4'), 142.0 (C-7), 133.5 (C-1'), 128.2 (C-1), 123.2 (C-6), 120.9 (C-6'), 118.7 (C-8), 116.4 (C-5'), 116.5 (C-5), 113.0 (C-2'), 111.5 (C-2), 56.5 (4-OMe, 3'-OMe), 42.4 (C-8'), 36.0 (C-7').

Compound 57. *N-trans-feruloyl tryptamine* (5 mg). MS: m/z 336 [M]⁺. ¹H NMR (CDCl₃/CD₃OD 4/1): □ 7.51 (1H, dd, J=7.6, 2.0 Hz, H-6'), 7.36 (1H, d, J=15.6 Hz, H-7), 7.29 (1H, dd, J=7.4, 2.2 Hz, H-3'), 7.07 (1H, m, H-5'), 6.98 (1H, m, H-4'), 6.97 (1H, s, H-2'), 6.90 (1H, dd, J=8.6 and 1.4 Hz, H-6), 6.88 (1H, d, J=1.4 Hz, H-2), 6.72 (1H, d, J=8.6 Hz, H-5), 6.13 (1H, d, J=15.6 Hz, H-8), 3.77 (3H, s, 3-OMe), 3.56 (2H, t, J=7.8

Hz, H-8'), 2.92 (2H, t, J=7.8, H-7'). ¹³C NMR [CDCl₃:CD₃OD (4:1)]: δ 167.0 (C-9), 147.6 (C-4), 147.2(C-3), 140.7 (C-7), 136.2 (C-3a'), 127.1 (C-1a'), 126.7 (C-1), 122.2 (C-2'), 121.8 (C-6), 121.4 (C-5'), 118.1(C-6'), 117.5 (C-8), 114.9 (C-4', C-5), 111.9 (C-1'), 111.1 (C-3'), 109.8 (C-2), 55.4 (3-OMe), 39.7 (C-8'), 24.9 (C-7').

Compound 58. *N-trans-4-O-methylferuloyl 3'-O-methyldopamine* (7 mg). EI-MS: *m/z* 357 [M]⁺. ¹H NMR (CDCl₃): δ 7.60 (1H, d, J=15.0 Hz, H-7), 7.11 (1H, dd, J=8.0, 1.5 Hz, H-6), 7.06 (1H, d, J=1.5 Hz, H-2), 6.90 (1H, d, J=8.0 Hz, H-5), 6.86 (1H, d, J = 7.8 Hz, H-5'), 6.84 (1H, d, J=1.5 Hz, H-2'), 6.76 (1H, dd, J=7.8, 1.5 Hz, H-6'), 6.25 (1H, d, J=15.0 Hz, H-8), 3.90 (6H, s, 3-OMe, 4-OMe), 3.88 (3H, s, 3'-OMe), 3.62 (2H, t, J=7.0 Hz, H-8'), 2.79 (2H, t, J=7.0, H-7'). ¹³C NMR: (CDCl₃): δ 166.1 (C-9), 150.5 (C-4), 149.1 (C-3), 145.7 (C-3'), 145.3(C-4'), 140.9 (C-7), 132.1 (C-1'), 127.8 (C-1), 122.0 (C-6), 120.2 (C-6'), 118.5 (C-8), 114.9 (C-2'), 111.0 (C-5), 110.9 (C-5'), 109.5 (C-2), 55.9 (3-OMe, 4-OMe, 4'-OMe), 40.8 (C-8'), 35.0 (C-7').

Compound 59. *Chenoalbicin* (32 mg). [α]_D²⁵ 0⁰ (c 0.02, CH₃OH). UV (MeOH): 196 (4.20), 227 (3.10), 283 (2.60). MALDI: 645 [M + K]⁺. ¹H NMR (CD₃OD): δ 7.43 (1H, d, J=15.5 Hz, H-7), 7.11 (1H, d, J=1.1 Hz, H-2), 7.06 (2H, d, J=8.0, H-6'and H-9''), 7.02 (2H, d, J= 8.5 Hz, H-6 and H-4''), 6.91 (1H, d, J=1.2 Hz, H12''), 6.79 (1H, H-2''), 6.76 (1H, H-1'), 6.75 (2H, H-2'and H-3''), 6.74 (2H, H-5 and H-10''), 6.72 (1H, H-5'), 6.38 (1H, d, J=15.5, H-8), 5.89 (1H, d, J=8.0Hz, H-13''), 4.14 (1H, d, J=8.0 Hz, H-13a''), 3.89 (1H, s, 3-OMe), 3.82 (1H, s, 4'-OMe), 3.54 (1H, dd, J=13.2 and 6.3 Hz, H-6''), 3.45 (1H, dd, J= 13.2 and 6.8 Hz, H-6''), 3.45 (1H, H-8'), 2.76 (1H, H-7'), 2.75 (1H, m, H-5''), ¹³C NMR: (CDCl₃): 172.9 (C-8''), 169.4 (C-9), 157.3 (C-3'), 151.4 (C-3), 149.4(C-4'), 148.2 (C-11''), 146.2 (C-4), 141.8 (C-7), 132.9 (C-12a''), 131.4 (C-1), 131.2 (C-4a''), 130.7 (C-9''), 130.6 (C-4'', C-6, C-6'), 130.4 (C-1'), 129.6 (C-1a''), 120.4 (C-8a''), 120.3 (C-2''), 119.4 (C-8), 118.3 (C-3''), 116.8 (C-5, C-5'), 116.7 (C-

1'', C-2', C-10''), 113.4 (C-2), 110.6 (C-12''), 90.0 (C-13''), 59 (C-13a''), 57.0 (3-OMe), 56.5 (4'-OMe), 42.8 (C-6''), 42.4 (C-8'), 36.0 (C-7'), 35.7 (C-5'').

Compound 60. (3*R*,6*R*,7*E*,9*E*,11*E*)-3-Hydroxy-13-*apo*- α -caroten-13-one (7 mg). $[\alpha]_D^{25} +251.0^\circ$ (c 0.006, CHCl₃). UV (CHCl₃) λ_{max} (log ϵ) 329 (4.3) nm. CD (CHCl₃) λ ($\Delta\epsilon$) 313.0 (+12.0) nm. EIMS m/z 274 [M]⁺ (60), 259 [M-Me]⁺ (40), 256 [M-H₂O]⁺ (100). ¹H NMR (CDCl₃): δ 7.58 (1H, dd, J = 11.5 and 15.0 Hz, H-11), 6.20 (2H, d, J= 15.0 Hz, H-8 and H-12), 6.18 (1H, d, J= 11.5 Hz, H-10), 5.69 (1H, dd, J= 9.5 and 15.0 Hz, H-7), 5.58 (1H, brs, H-4), 4.26 (1H, brs, H-3), 2.44 (1H, d, J= 9.5 Hz, H-6), 2.30 (3H, s, H-14), 2.01 (3H, s, H-18), 1.84 (1H, dd, J = 6.4 and 17.5 Hz, H-2_{eq}), 1.62 (3H, s, H-17), 1.40 (1H, dd, J= 5.8, 17.5, H-2_{ax}), 1.01 (3H, s, H-15), 0.86 (3H, s, H-15). ¹³C NMR (CDCl₃): δ 198.6 (C-13), 144.5 (C-9), 139.0 (C-11), 137.2 (C-5), 136.9 (C-8), 133.6 (C-7), 129.8 (C-12), 127.8 (C-10), 125.0 (C-4), 65.8 (C-3), 54.9 (C-6), 44.5 (C-2), 34.0 (C-1), 29.5 (C-15), 27.7 (C-14), 22.8 (C-17), 13.5 (C-18).

Compound 61. (6*S*,7*E*,9*E*,11*E*)-3-Oxo-13-*apo*- α -caroten-13-one (8 mg). $[\alpha]_D^{25} +165.0^\circ$ (c 0.008, CHCl₃). UV (CHCl₃) λ_{max} (log ϵ) 323 (3.3) nm. CD (CHCl₃) λ ($\Delta\epsilon$) 320.0 (+43.0) nm. EIMS m/z 288 [M]⁺ (50), 273 [M-Me]⁺ (100), 245 [M-MeCO]⁺ (30). ¹H NMR (CDCl₃): δ 7.55 (1H, dd, J=11.5 and 15.5 Hz, H-11), 6.47 (1H, d, J=15.9 Hz, H-8), 6.26 (1H, d, J=11.5 Hz, H-10), 6.24 (1H, d, J=15.5 Hz, H-12), 5.96 (1H, d, J=15.9 Hz, H-7), 5.94 (1H, s, H-4), 2.50 (1H, d, J=17.5 Hz, H-2_{eq}), 2.30 (1H, d, J=17.5 Hz, H-2_{ax}), 2.30 (3H, s, H-14), 2.02 (3H, s, H-18), 1.91 (3H, s, H-17), 1.11 (3H, s, H-15), 1.03 (3H, s, H-16). ¹³C NMR (CDCl₃): δ 198.4 (C-3, C-13), 161.0 (C-5), 143.2 (C-9), 138.4 (C-11), 134.6 (C-8), 132.0 (C-7), 130.3 (C-10, C-12), 127.1 (C-4), 80.1 (C-6), 49.7 (C-2), 41.6 (C-1), 28.5 (C-14), 24.3 (C-16), 23.1 (C-15), 18.9 (C-17), 14.0 (C-18).

Compound 62. S-(+)-Abscisic alcohol (13 mg). $[\alpha]_D^{25} +210.0^\circ$ (c 0.012, CHCl₃). EIMS m/z 250 [M]⁺ (80), 235 [M-Me]⁺ (100). ¹H NMR (CDCl₃): δ 7.74 (1H, d, J= 15.5 Hz,

H-7), 6.34 (1H, d, J=15.5 Hz, H-8), 5.92 (1H, s, H-4), 5.74 (1H, d, J=15.5 Hz, H-7), 5.73 (1H, obscured, H-10), 4.35 (2H, bs, H-11), 2.45 (1H, d, J=16.6 Hz, H-2a), 2.27 (1H, d, J=16.6 Hz, H-2b), 1.91 (3H, s, H-14), 1.81 (3H, s, H-15), 1.10 (3H, s, H-12), 1.01 (3H, s, H-13). ^{13}C NMR (CDCl_3): δ 198.0 (C-3), 163.0 (C-5), 137.0 (C-9), 134.8 (C-8), 131.6 (C-10), 128.4 (C-7), 126.9 (C-4), 78.0 (C-6), 59.3 (C-11), 49.8 (C-2), 42.0 (C-1), 23.0 (C-13), 23.0 (C-12), 18.8 (C-14), 12.9 (C-15).

Compound 63. *Grasshopper ketone* (12 mg). $[\alpha]_{\text{D}}^{25} -62.0^\circ$ (c 0.012, CHCl_3). EIMS m/z 224 $[\text{M}]^+$ (10), 209 $[\text{M-Me}]^+$ (100), 191 $[\text{M-Me-H}_2\text{O}]^+$ (20). ^1H NMR (CDCl_3): δ 5.84 (1H, s, H-8), 4.35 (1H, m, H-3), 2.30 (2H, overlapped, H-2), 2.17 (3H, s, H-10), 2.00 and 1.39 (1H, m, H-4), 1.42 (3H, s, H-13), 1.37 (3H, s, H-11), 1.15 (3H, s, H-12). ^{13}C NMR (CDCl_3): δ 209.2 (C-9), 198.6 (C-7), 118.9 (C-6), 101.1 (C-8), 72.4 (C-5), 63.9 (C-3), 49.2 (C-4), 48.9 (C-2), 31.9 (C-11), 36.4 (C-1), 31.2 (C-10), 29.3 (C-13), 26.5 (C-10).

Compound 64. (5 mg). $[\alpha]_{\text{D}}^{25} -32.0^\circ$ (c 0.018, CHCl_3). EIMS m/z 224 $[\text{M}]^+$ (30), 209 $[\text{M-Me}]^+$ (100), 191 $[\text{M-Me-H}_2\text{O}]^+$ (40). ^1H NMR (CDCl_3): δ 5.85 (1H, s, H-8), 4.34 (1H, m, H-3), 1.48 and 2.29 (2H, m, H-2), 1.42 and 2.00 (2H, m, H-4), 1.16 (3H, s, H-11), 1.38 (3H, s, H-12), 1.43 (3H, s, H-13), 2.19 (3H, s, H-10). ^{13}C NMR (CDCl_3): δ 209.7 (C-9), 198.3 (C-7), 118.8 (C-6), 100.8 (C-8), 72.3 (C-5), 63.9 (C-3), 49.0 (C-2), 48.7 (C-4), 36.1 (C-1), 31.7 (C-12), 30.9 (C-13), 29.1 (C-11), 26.3 (C-10).

Compound 65. (8 mg). $[\alpha]_{\text{D}}^{25} -28.0^\circ$ (c 0.052, CHCl_3). EIMS m/z 224 $[\text{M}]^+$ (30), 209 $[\text{M-Me}]^+$ (100), 191 $[\text{M-Me-H}_2\text{O}]^+$ (10). ^1H NMR (CDCl_3): δ 1.10 (3H, s, H-11), 1.39 (3H, s, H-12), 1.41 (3H, s, H-13), 2.25 (3H, s, H-10), 1.98 (2H, m, H-2), 1.91 and 2.20 (2H, m, H-4), 4.30 (1H, m, H-3), 5.97 (1H, s, H-8). ^{13}C NMR (CDCl_3): δ 209.4 (C-9), 199.1 (C-7), 118.7 (C-6), 100.1 (C-8), 72.4 (C-5), 63.9 (C-3), 48.7 (C-2 and C-4), 35.9 (C-1), 31.9 (C-12), 30.9 (C-13), 29.1 (C-11), 27.1 (C-10).

Compound 66. (3*R*,6*R*,7*E*)-3-Hydroxy-4,7-megastigmadien-9-one (5 mg). $[\alpha]_D^{25} +37.0^\circ$ (*c* 0.05, MeOH). CD $\Delta\epsilon_{239} = +24$. $^1\text{H NMR}$ (CD_3OD): δ 6.51 (1H, dd, *J*= 15.5 and 5.3, H-7), 6.10 (1H, d, *J*=15.5, H-8), 5.60 (1H, s, H-4), 4.27 (1H, bs, H-3), 2.50 (1H, d, *J*=5.3 Hz, H-6), 2.27 (1H, s, H-10), 1.80 (1H, dd, *J*=13.5 and 6.3, H-2), 1.35 (1H, dd, *J*=13.5 and 5.8, H-2), 1.24 (3H, s, H-13), 1.02 (3H, s, H-11), 0.88 (3H, s, H-12). $^{13}\text{C NMR}$ (CD_3OD): δ 199.0 (C-9), 147.0 (C-7), 135.4 (C-5), 133.5 (C-8), 126.0 (C-4), 65.6 (C-3), 54.3 (C-6), 44.0 (C-2), 33.9 (C-1), 29.2 (C-11), 27.0 (C-10), 24.7 (C-12), 22.8 (C-13).

Compound 67. (3*R*,6*R*,7*E*,9*R*)-3,9-Dihydroxy-4,7-megastigmadiene (7 mg). $[\alpha]_D^{25} 0^\circ$ (*c* 0.05, MeOD). $^1\text{H NMR}$ (CD_3OD): δ 5.59 (1H, dd, *J*= 15.5 and 5.4 Hz, H-8), 5.38 (1H, dd, *J*=15.5 and 8.1 Hz, H-7), 5.52 (1H, bs, H-4), 4.33 (1H, m, H-9), 4.21 (1H, brs, H-3), 2.32 (1H, d, *J*= 8.1 Hz, H-6), 1.82 (1H, dd, *J*=13.5 and 5.8 Hz, H-2_{ax}), 1.61 (3H, s, H-13), 1.36 (1H, dd, *J*=13.5 and 6.3 Hz, H-2_{eq}), 1.28 (1H, d, *J*= 6.5 Hz, H-10), 0.99 (3H, s, H-11), 0.84 (3H, s, H-12). $^{13}\text{C NMR}$ (CD_3OD): δ 137.6 (C-8), 137.4 (C-5), 129.1 (C-7), 124.6 (C-4), 68.7 (C-9), 65.8 (C-3), 54.0 (C-6), 44.4 (C-2), 33.4 (C-1), 29.4 (C-12), 24.0 (C-11), 23.6 (C-10), 22.6 (C-13).

Compound 68. (6*R*,7*E*)-4,7-Megastigmadien-3,9-dione (10 mg). $[\alpha]_D^{25} +200.0^\circ$ (*c* 0.012, CHCl_3). EIMS *m/z* 206 $[\text{M}]^+$ (10), 108 $[\text{C}_7\text{H}_8\text{O}]^+$ (100). $^1\text{H NMR}$ (CDCl_3): δ 6.68 (1H, dd, *J*=15.5 and 5.6 Hz, H-7), 6.17 (1H, d, *J*=15.5 Hz, H-8), 5.99 (1H, s, H-4), 2.70 (1H, d, *J*=16.8 Hz, H-2), 2.39 (1H, s, H-6), 2.30 (1H, s, H-10), 2.18 (1H, d, *J*=16.8 Hz, H-2), 1.90 (3H, s, H-13), 1.10 (3H, s, H-11), 1.02 (3H, s, H-12).

Compound 69. (6*R*,9*R*)-9-Hydroxy-4-megastigmen-3-one (5 mg). $[\alpha]_D^{25} +84.0^\circ$ (1.0, CHCl_3). $^1\text{H NMR}$ (CDCl_3): δ 5.84 (1H, s, H-4), 3.78 (1H, m, H-9), 2.39 and 2.04 (2H, d, *J*=16.9, H-2), 1.99 (3H, d, *J*=1.3, H-13), 1.21 (3H, d, *J*=6.3, H-10), 1.07 (3H, s, H-11), 1.02 (3H, s, H-12), 1.00-1.90 (3H, overlapped, H-6, H-7 and H-8). $^{13}\text{C NMR}$

(CDCl₃): δ 199.6 (C-3), 165.8 (C-5), 125.1(C-4), 68.0 (C-9), 51.1 (C-6), 47.1 (C-2), 38.6 (C-8), 36.2 (C-1), 26.2 (C-7), 28.8 (C-12), 27.2 (C-11), 24.6 (C-10), 23.7 (C-13).

Compound 70. *3,9-Dihydroxy-4-megastigmene* (2 mg). $[\alpha]_D^{25} +80.0^\circ$ (c 0.08, CH₃OH).

¹H NMR (CD₃OD): δ 5.38 (1H, bs, H-4), 3.78 (1H, m, H-9), 4.28 (1H, m, H-3), 2.00 (1H, t, J= 8.1 Hz, H-6), 1.82 (1H, dd, J=13.5 and 5.8 Hz, H-2), 1.61 (3H, s, H-13), 1.36 (1H, dd, J=13.5 and 6.3 Hz, H-2), 1.21 (3H, d, J=6.3, H-10), 0.99 (3H, s, H-11), 0.84 (3H, s, H-12). ¹³C NMR (CD₃OD): δ 137.4 (C-5), 124.6 (C-4), 68.0 (C-9), 65.8 (C-3), 56.0 (C-6), 44.4 (C-2), 38.6 (C-8), 33.4 (C-1), 29.4 (C-12), 26.2 (C-7), 24.0 (C-11), 24.6 (C-10), 22.6 (C-13).

Compound 71. *4-Megastigmen-3,9-dione* (12 mg). $[\alpha]_D^{25} -1.5^\circ$ (c 0.050, CHCl₃).

EIMS *m/z* 208 [M]⁺ (40), 193 [M-Me]⁺ (100). 165 [M-MeCO]⁺ (50). ¹H NMR (CDCl₃): δ 1.01 (3H, s, H-11), 1.05 (3H, s, H-12), 1.24 (2H, m, H-7), 1.74 (1H, m, H-6), 1.99 (3H, s, H-13), 2.15 (3H, s, H-10), 2.29 and 2.52 (2H, d, J=8.4 Hz, H-2), 2.29 and 2.54 (2H, m, H-8), 5.84 (1H, s, H-4). ¹³C NMR (CDCl₃): δ 207.0 (C-9), 199.1 (C-3), 164.8 (C-5), 125.6 (C-4), 50.1 (C-6), 47.0 (C-2), 42.5 (C-1), 28.8 (C-10 and C-11), 27.3 (C-12), 24.6 (C-7) 23.4 (C-8 and C-13).

Compound 72. *3,6,9-Trihydroxy-4-megastigmene* (1mg). $[\alpha]_D^{25} +66.0^\circ$ (c 0.020,

CH₃OH). EIMS *m/z* 228 [M]⁺ (20), 213 [M-Me]⁺ (100). 195 [M-Me-H₂O]⁺ (40). ¹H NMR (CD₃OD): δ 5.35 (1H, s, H-4), 4.10 (1H, m, H-3), 3.65 (1H, m, H-9), 1.73 (3H, s, H-13), 1.47-1.53 (2H, m, H-7), 1.20-1.25 (2H, m, H-8), 1.40 and 1.53 (2H, m, H-2), 1.15 (3H, s, H-10), 0.98 (3H, s, H-12), 0.90 (3H, s, H-11). ¹³C NMR (CD₃OD): δ 141.2 (C-5), 125.6 (C-4), 69.7 (C-6), 69.4 (C-9), 67.5 (C-3), 40.9 (C-2), 36.1 (C-1), 29.5 (C-11), 28.6 (C-12), 28.4 (C-7) 23.9 (C-8), 24.0 (C-10), 23.5 (C-13).

Compound 73. *(6Z,9S)-9-Hydroxy-4,6-megastigmadien-3-one* (5 mg). $[\alpha]_D^{25} +28.5^\circ$

(0.5, CHCl₃). ¹H NMR (CDCl₃): δ 5.92 (1H, s, H-4), 5.74 (1H, t, J=7.0, H-7), 3.94 (1H,

m, H-9), 2.48 (2H, m, H-8), 2.30 (2H, s, H-2), 2.23 (3H, s, H-13), 1.25 (1H, d, J=6.0, H-10), 1.18 (6H, s, H-11 and H-12). ^{13}C NMR(CDCl_3): δ 199.1 (C-3), 155.9 (C-6), 144.6 (C-5), 129.0 (C-4), 126.6 (C-7), 68.2 (C-9), 53.0 (C-2), 40.9 (C-1), 39.6 (C-8), 28.1 (C-12), 28.0 (C-11), 24.8 (C-13), 23.5 (C-10).

RESULTS AND DISCUSSION

Three spontaneous plants of the Mediterranean area have been investigated, *Brassica fruticulosa*, *Chenopodium album*, *Malva silvestris*, in order to study the metabolites they produce and to determine whether or not they possess biological activity.

These plants were chosen because of their characteristics of persistency and diffusion, both of which are promising features for plant allelopathy.

Metabolites extraction was realised using two different techniques for the three plants. Simple infusions in hydroalcoholic solutions (10% MeOH/H₂O) and then pure methanol was used for *Brassica fruticulosa* and *Chenopodium album*, while the extractor Naviglio (Naviglio 2003) was employed for *Malva silvestris*.

Infusion procedure is conducted by immersing fresh plants in hydroalcoholic or alcoholic solvent for 7 days, and then filtering the infused plants to remove solid particles of macerated plants. Naviglio extractor was used to guarantee higher yields of extracted metabolites from *Malva silvestris*. Repeated extraction cycles were performed with the automatic extractor at high pressure values, to stimulate the releasing of the internal compounds of plants cells by suction effect. This mechanism allows the extraction of both hydrophobic and hydrophilic compounds from matrix cells simply by employing water as extracting solvent. Environmental and economic advantages are two of the benefits deriving from the use of the extractor, which also guarantees mimicking natural processes as well as possible.

All the extracts obtained were concentrated and fractionated with chromatographic techniques (CC, TLC, HPLC, DCCC). Identification of pure compounds has been carried out by using Mass Spectrometry (EI MS, MALDI MS, GC MS), NMR

spectroscopy on ^1H and ^{13}C by one-dimensional and two-dimensional experiments, IR, UV, CD.

For each plant the isolated compounds are described one by one and the investigation modalities that allowed their structural elucidation are reported.

Brassica fruticulosa

Brassica fruticulosa is a terrestrial plant of Brassicaceae family. This family includes more than 2000 species distributed world-wide, abundantly represented in the boreal hemisphere. Italian varieties, including *Brassica fruticulosa*, are an important economic resource for the country. In fact, they are employed as vegetables, forage, fertilizers and for industrial or dressing oil extraction. Some varieties have medical properties (against scurvy), while some others are harvested for ornamental purposes.



fig.1-*Brassica fruticulosa*

From *Brassica fruticulosa* Cyr. and *B. oleracea* L. derive different types of cabbages, while *Brassica hirta*, *B. nigra*, or *B. juncea* supply the seeds for mustard preparation. These plants are also used in medicine as a stimulant and diuretic, emetic, or counterirritant. *Brassica fruticulosa* is widely found in south Italy and it is deeply appreciated in Sicily as a salad ingredient and for the preparation of pasta dishes.

The extraction of secondary metabolites from *Brassica fruticulosa* was realized by infusing fresh plants in 10% MeOH/H₂O for seven days, and then in pure MeOH. The extracts were partitioned between methylene chloride and water. The methylene chloride extracts were fractionated by silica gel column chromatography and the fractions were purified by preparative TLC, DCCC and HPLC, yielding four lignans, three neolignans, one sesquilignan, one dilignan (Cuttillo *et al.*, 2003) and four C-13 *nor*-terpenes (Cuttillo *et al.*, 2005). The aqueous extracts were chromatographed on Amberlite XAD-2 and fractionated by Sephadex LH-20 column chromatography. The fractions obtained were purified with preparative TLC, DCCC and HPLC, yielding one lignan, two neolignans, one sesquilignan and one *nor*-terpene.

Lignans are constituted by phenyl-propane monomers linked to give di-, tri- and tetrameric structures. Repeating units of lignans generate lignins, which are involved in the lignification of plant cell walls to generate solid structures and watering conduction systems in trees.

C-13 *nor*-terpenes are molecules having a skeleton consisting of thirteen carbon atoms, identified in many common plants. They are generally found as aroma compounds in fruits and vegetables, but also in many leaf products such as tea or tobacco. C-13 *nor*-isoprenoids are supposed to be structurally derived from higher molecular weight terpenoids such as carotenoids, through degradation processes.

Compound **1** was identified as (-)-pinoresinol by analysing the spectroscopic data of the molecule, and comparing them to literature (*Lin-gen et al. 1982*). It has a molecular formula $C_{20}H_{22}O_6$ as deduced from the molecular peak m/z 358 in a EI MS spectrum. The ^{13}C NMR spectrum shows ten signals, that from a DEPT experiment were deduced to be three methines (δ_C 108.6, 114.3 and 118.9) and three quaternary carbons (δ_C 132.9, 146.7 and 145.2), in the aromatic region. At higher fields the signals of a methylenic carbon at δ 71.6, a benzylic methine at δ 85.8, an aliphatic methine carbon at δ 54.1 and a methylic carbon at δ 55.9 are present. These data are in agreement with a dioxabicyclic system, having two condensed furanic rings symmetrically substituted by phenylic rings.

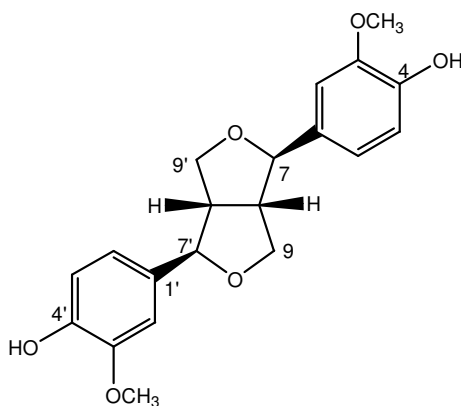

1

According to this hypothesis, 1H NMR spectrum shows three aromatic protons of a 1,2,4-trisubstituted system, a benzylic proton bonded to an oxygen atom at δ 4.74 (d, $J=4.0$ Hz), two double doublet due to the two diastereotopic protons of the methylenic group at δ 4.25 ($J= 7.0$ and 9.0 Hz), and δ 3.88 ($J= 4.0$ and 9.0 Hz), a multiplet at δ 3.10 of a methinic proton, and finally the signal due to three methoxyl protons at δ 3.91. Chemical shift values and couplings of the protons H-7 and H-9 define the relative configuration of the compound. The absolute configuration is established by the

measure of the optical rotation ($[\alpha]_D^{25} -10^\circ$) and comparing it to literature values (*Lingen et al. 1982*).

Compound **2** has been identified as (-)-isolariciresinol. In the ^{13}C NMR spectrum nineteen signals are present, which were defined through a DEPT experiment as: seven quaternary carbons and five methins between δ 112.0 and δ 150.0, three methylenic carbons at δ 66.5, 62.8 and 34.1; two methylic carbons at δ 56.9; three methinic carbons between δ 40.0 and δ 49.0. In the ^1H NMR spectrum five aromatic protons are present, attributed to two phenyl groups. One ring resonates as two methine doublet protons at δ 6.74 (d, $J= 8.1$ Hz, H-5) and at δ 6.67 (d, $J=1.8$ Hz, H-2), and a methine double doublet at δ 6.62 ($J= 8.1$ and 1.8 Hz, H-6), while two methine singlets at δ 6.65 (H-5') and 6.19 (H-2') are due to the second ring. At higher fields a methylene doublet is present at δ 2.77, which is due to the H-7' protons. From a $^1\text{H}^1\text{H}$ COSY experiment, it results that these protons are coupled to the multiplet at δ 2.00 (H-8'), which is also correlated to a multiplet due the methylenic group at δ 3.82 (H-9').

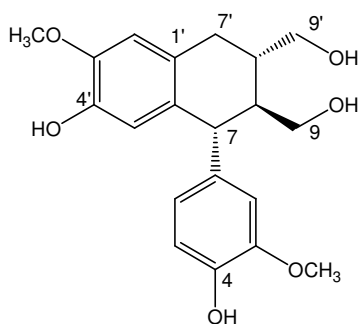

2

The methine triple triplet at 1.74 (H-8) is correlated to a methine doublet at δ 3.83 (H-7) and to two methine double doublet at δ 3.81 (H-9a) and 3.40 (H-9b). Correlation

between H-8 and H-8' confirms the presence of the cyclohexane ring that links the two C₃ lateral chains. Finally the signals of the methyl group of two methoxyl protons are at δ 3.80 and 3.76. NOE experiments confirm the positions occupied by the two methoxyl groups on the aromatic rings. Couplings of H-7 (d, J=10.0 Hz), H-8 (tt, J=10.0 and 3.0 Hz), H-7' (d, J=7.2 Hz), H-9a (dd, J=11.0 and 3.0 Hz) define the relative configuration of the compound, while the absolute configuration (7*S*, 8*R*, 8'*R*) is derived from the measure of the optical rotation ($[\alpha]_D^{25} -30^\circ$) (Urones *et al.* 1987).

Compound **3** is (+)-secoisolariciresinol. MALDI spectrum of the molecule shows a molecular peak at *m/z* 362, which is compatible with a molecular formula C₂₀H₂₆O₆.

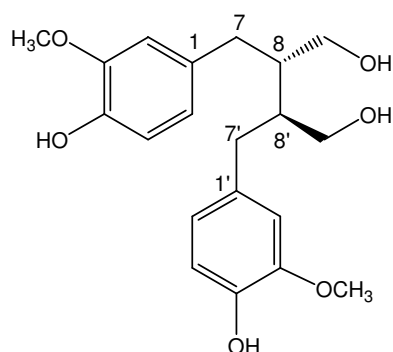

3

The ¹³C NMR spectrum shows only ten signals due to the symmetry of the molecule. By means of a DEPT experiment, we can define the presence of three quaternary carbons, four methines, two methylenes and one methyl. ¹H NMR analysis shows two 1,2,4-trisubstituted aromatic systems and two C₃ side chains. The two protons at C-7 give resonances at δ 2.56 and 2.67, each as a double doublet, H-8 resonates as a multiplet at δ 1.90, and the two H-9 protons appear as a unique multiplet at δ 3.60.

Comparison of the optical rotation measured ($[\alpha]_D^{25} +28.1$) with literature data allows the absolute configuration of the molecule to be assigned as $8R, 8'R$ (Fonseca *et al.* 1978).

Compound **4** is (\pm)-lariciresinol. A DEPT experiment assigned the eighteen signals of the ^{13}C -NMR spectrum to six quaternary carbons and six methines in the aromatic range, three methylenes at δ 32.3, 59.1 and 72.1 and three methine carbons at δ 82.3, 42.1 and 52.2. The signals of two 1,2,4-trisubstituted aromatic systems are present in the ^1H NMR spectrum between δ 6.40 and δ 6.90. Higher field signals of two multiplets were assigned to the methine protons H-8' (δ_{H} 2.35) and H-8 (δ_{H} 2.74). The multiplet at δ 3.74, integrated for two protons, is attributed to both H-9' protons, while the four double doublets at δ 3.80 ($J=8.1$ and 6.0 Hz), 4.00 ($J=8.1$ and 6.0 Hz), 2.45 ($J=13.0$ and 10.0 Hz), and 2.87 ($J=13.0$ and 5.0 Hz) are due to H-9a, H-9b, H-7b and H-7a, respectively. The signals of the proton H-7' is at δ 4.80 (d, $J=6.0$ Hz). The six methoxyl protons resonate at δ 3.82.

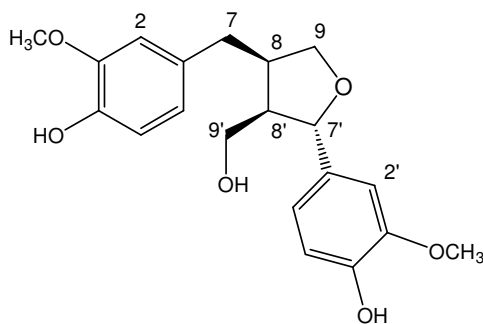

4

In a ^1H - ^1H COSY experiment the proton H-7' was correlated to the proton H-8' at δ 2.35, which is, in turn, coupled to the two protons H-9' both at δ 3.74. Proton H-7b at δ 2.45 is coupled to the proton H-7a at δ 2.87, and both of them give correlations with the

proton H-8 at δ 2.74, and the two protons H-9. The presence of a tetrahydrofuran ring is confirmed by the scalar correlation between H-8 and H-8'. Couplings settle the relative configuration of the isolated diastereoisomer (*Fonseca et al. 1978*).

Compound **5** has been identified as tanegol. The molecular ion peak at m/z 376 in a MALDI MS spectrum is in agreement with a molecular formula $C_{20}H_{24}O_7$. The ^{13}C NMR spectrum presents nineteen signals. In the aromatic area twelve signals are present, they were assigned by a DEPT experiment to six quaternary carbons and six methines; four methine carbons give resonances at δ 83.8, δ 75.4, δ 49.5 and δ 52.3, two methylenes at δ 70.3 and 61.1, and finally the signals of two methyl carbons of two methoxy groups are present at δ 55.2. The $^1H^1H$ COSY spectrum shows that two 1,2,4-trisubstituted phenyl rings are present. Cross-peaks between the two methoxy-groups and protons H-2 and H-2' in a NOESY experiment define the guaiacylic structure of the aromatic rings. Protons correlation experiments define the presence of two 1,3-dihydroxypropanolic units. The two C_3 units are linked together through the carbons C-8/C-8'. The data obtained define the presence of a tetrahydrofuranic ring. The cross peaks present in a NOESY experiment between H-7/H-9a, 9b, 9' α ; H-8/H-2, 6, 7' and H-7'/H-9' β define the relative configuration of the molecule as 7*R*, 8*R*, 8'*S*, 7'*R* or 7*S*, 8*S*, 8'*R*, 7'*S* (*Abe et al. 1990*).

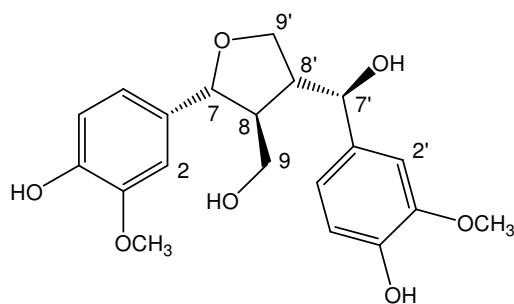

5

Compound **6** has been identified as (\pm)-dehydrodiconiferyl alcohol. Because of the molecular ion peak at m/z 358 in the EI-MS spectrum and to the ^{13}C NMR spectrum having nineteen signals, the molecular formula $\text{C}_{20}\text{H}_{22}\text{O}_6$ was assigned. Carbon signals were assigned by a DEPT experiment as seven quaternary carbons, nine methines, two methylenes and two methyls. At δ 88.2 a highly deshielded benzylic carbon gives resonance, while between δ 50 and 66 there are the signals of two methylene carbons and two CH_3 of a methoxy-group. In the ^1H NMR spectrum two aromatic systems 1,2,4-trisubstituted and 1,2,3,5-tetrasubstituted resonate in the chemical shift range δ 6.70-7.00, while at higher field the double triplet of the proton H-8' (δ_{H} 6.18). is present. The $^1\text{H}^1\text{H}$ COSY experiment correlates the proton H-8' to the doublet at δ 6.55, assigned to the proton H-7', and to the double doublet of the two protons H-9' at δ 4.29. The proton H-7 (δ_{H} 5.58) is correlated by the same experiment to the proton H-8 at δ 3.50. The latter is coupled to the H-9 protons at δ 3.79. Six protons resonating at δ 3.85 are assigned to the methoxyl-groups. NOE experiments confirm the substituents position on the rings. Spectroscopic data define the relative configurations of the chiral centres. Compound **6** has been isolated as a racemic mixture (*Yuen et al. 1998*).

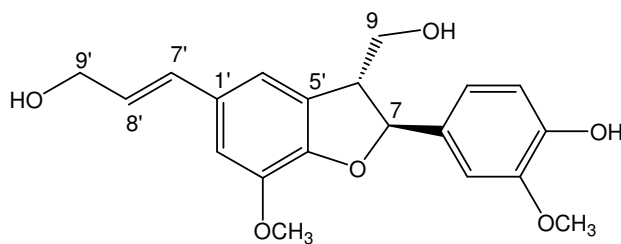

6

Compound **7** has been defined as (\pm)-*threo*-guaiacylglycerol- β -*O*-4'-coniferyl ether from the analysis of its spectroscopic data. Its molecular formula $C_{20}H_{24}O_7$ has been derived from an EI-MS experiment, which shows a molecular ion peak at m/z 376. Twenty signals are present in the ^{13}C NMR spectrum and they are distributed in the following manner: twelve signals in the aromatic area, which according to a DEPT experiment are due to six quaternary carbons and six methine carbons, two olefinic CH at δ 133.8 and 122.2, two very deshielded aliphatic methine carbons at δ 73.8 and 80.0, two methylene groups whose chemical shift (δ 62.9 and δ 65.0) suggests they are directly linked to an oxygen atom. Finally the carbons of two methoxyls resonate at δ 56.6 and 55.8.

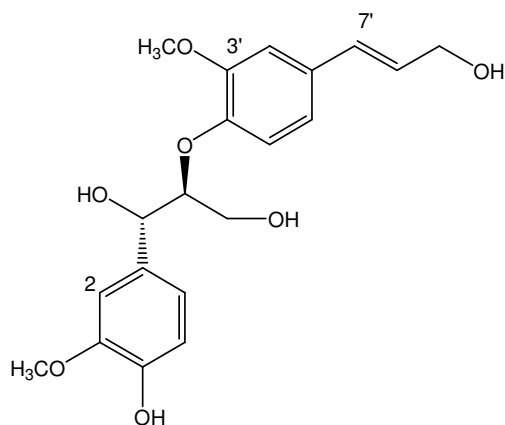

7

Two ABX-type spin systems are present in the 1H NMR spectrum and are attributed to two 1,2,4-trisubstituted aromatic rings. The large doublet at δ 6.51 is due to the olefinic proton H-7' that in a $^1H^1H$ COSY spectrum is coupled to the olefinic proton at δ 6.23 (H-8'). *Trans* configuration of the double bond derives from the couplings value ($J=15.8$ Hz). The proton H-8' is in turn coupled to the signal at δ 4.20, attributed to the two methylenic protons in 9'. A second three-carbons side chain is also detected from

the correlation of the protons H-7 (δ 4.83)/ H-8 (δ 4.36)/ H-9a and b (δ 3.84 and δ 3.76). In HMBC experiment the proton H-7 shows cross-peaks with the carbons C-2 and C-6, while the olefinic proton H-7' is correlated to the signals δ 110.2 and 119.7 of the two aromatic carbons C-2' and C-6'. The two methoxyl groups are positioned on C-3 and C-3', by considering the NOE effect they give with protons H-2 and H-2', respectively. The coupling J_{7-8} (6.0 Hz) defines a *threo* relative chirality at the C-7 and C-8. The compound has been isolated as a racemic mixture (*Li et al. 1998*).

Compound **8** had a molecular ion peak in a ESI MS experiment at m/z 406, according to a molecular formula $C_{21}O_8H_{26}$. The ^{13}C NMR spectrum shows only nineteen signals, ten of which at high chemical shift values were assigned through a DEPT experiment to seven quaternary carbons and five methines. At δ 131.7 and 130.1 there are the signals of two olefinic methines. Moreover two highly deshielded methine carbons are identified in the chemical shift range δ 70.0-90.0. Two methylene carbons give resonance at δ 61.7 and 63.8, and the high chemical shift values suggest the presence of carbons directly linked to oxygen atoms. Around δ 56.0, the signals of three methoxylic carbons are present.

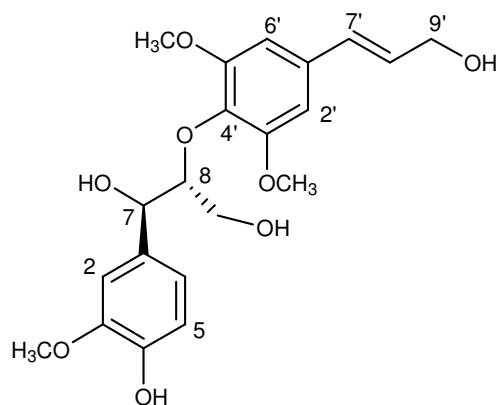

8

In the ^1H NMR spectrum there are thirteen signals, five of them are typical of two aromatic rings, one 1,2,4-trisubstituted and one 1,2,3,5-tetrasubstituted. The large doublet at δ 6.55 is assigned to the olefinic proton H-7', which was correlated in a $^1\text{H}^1\text{H}$ COSY spectrum to the olefinic proton at δ 6.30 (H-8'). The *trans* geometry of the double bond is defined by the coupling value of 15.8 Hz. Proton H-8' is further coupled to the signal at δ 4.22 due to the two protons H-9'. Correlated protons H-7 (δ 4.92), H-8 (δ 4.22) and H-9a and b (δ 3.87 and δ 3.55) are attributed to the trihydroxypropanolic carbons chain. The coupling constant value $J_{7-8}=5.1$ Hz is indicative of a *threo* relative configuration of C-7 and C-8. The absolute configuration 7*R*, 8*R* derives from the negative CD curve in the 210-250 nm range. Compound **8** is identified as (+)-*threo*-guaiacylglycerol- β -O-4'-synapyl ether, which had been previously isolated as a glycoside from the bark of *Eucommia ulmoides* (Takeshi *et al.* 1987).

Compound **9** has been isolated for the first time. It has been identified as (\pm)-*erythro*-syringylglycerol- β -O-4'-synapyl ether. The EI MS spectrum has a molecular peak at m/z 436 consistent with a molecular formula $\text{C}_{22}\text{H}_{28}\text{O}_9$. It shows only 17 carbon signals in the ^{13}C NMR spectrum and a DEPT experiment defined the carbons as four methyls, two methylenes, eight methines and eight quaternary carbons. The ^1H NMR spectrum shows four aromatic protons as two singlets at δ 6.69 and 6.58, which are typical of 1,3,4,5-tetrasubstituted aromatic rings.

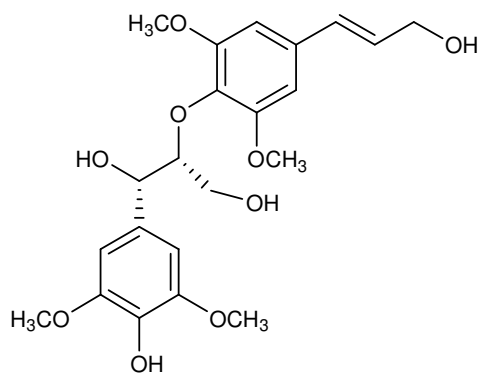

9

The ^1H NMR spectrum and the $^1\text{H}^1\text{H}$ COSY allow us to identify the H-7' doublet at δ 6.57 ($J=15.8$ Hz), the H-8' double triplet at δ 6.36 ($J=15.8$ and 5.8 Hz) and the H-9' double doublet at δ 4.36 ($J=5.8$ and 1.5 Hz), as well as the H-7 doublet at δ 4.99 ($J=4.0$ Hz), the H-8 multiplet at δ 4.12 and the H-9 double doublets at δ 3.86 (partially obscured, H-9a) and 3.49 ($J=12.0$ and 3.0 Hz, H-9b). In the ^1H NMR spectrum four methoxyl groups at δ 3.92, 3.90, 3.89 and 3.88 are also present. In accordance with the *erythro* relative configuration, a coupling value of 4.0 Hz between H-7 and H-8 is observed.

Compound **10** has a molecular ion peak in a ESI MS at m/z 370, which indicates a molecular formula $\text{C}_{20}\text{H}_{18}\text{O}_7$. The ^1H NMR spectrum has the signals of an aromatic ring whose protons resonate in a ABX spin system, and of an olefinic system conjugated to an unsaturated function. The signal of a methoxyl is also present at δ 3.80. By comparison with previously reported spectroscopic data, this compound has been identified as 1-feruloyloxy-2-methoxy cinnamic acid (*Huang et al. 2000*).

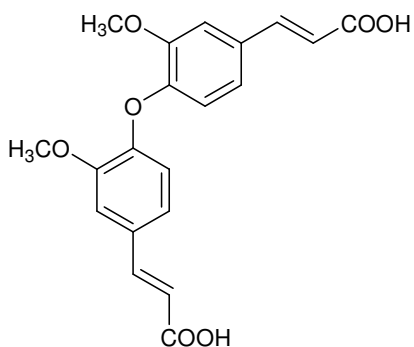

10

Compound **11** has molecular formula $C_{42}H_{50}O_{16}$ according to the molecular ion peak at m/z 833 $[M+Na]^+$ in the MALDI/MS spectrum. In the ^{13}C NMR spectrum only twenty-one carbon signals are present indicating a highly symmetric molecule. Through a DEPT experiment these signals are attributed to fourteen quaternary carbons, eighteen methines, six methyls and four methylenes. The 1H NMR and COSY spectra reveal the connectivities of four protons characteristic of the 3,7-dioxabicyclo [3.3.0] octane (4.79/H-7 and 7', 3.14/H-8 and 8', 4.34/H-9a and 9'a, 3.98/H-9b and 9'b), and propane 1,2,3-triol groups (5.00/ H-7'' and 7''', 4.14/ H-8'' and 8''', 3.88/ H-9''a and 9'''a, 3.51/ H-9''b and 9'''b). Cross-peaks in an HMBC experiment confirm the carbons' skeleton. Correlation between H-8''/8''' and C-4/4' defines the linking position of the guaiacylglycerol units on the rings. The above data match those reported by *Matsuda et al. (1984)* for hedyotisol-A isolated from *Hedyotis lawsoniae* and identified as a hexaacetate.

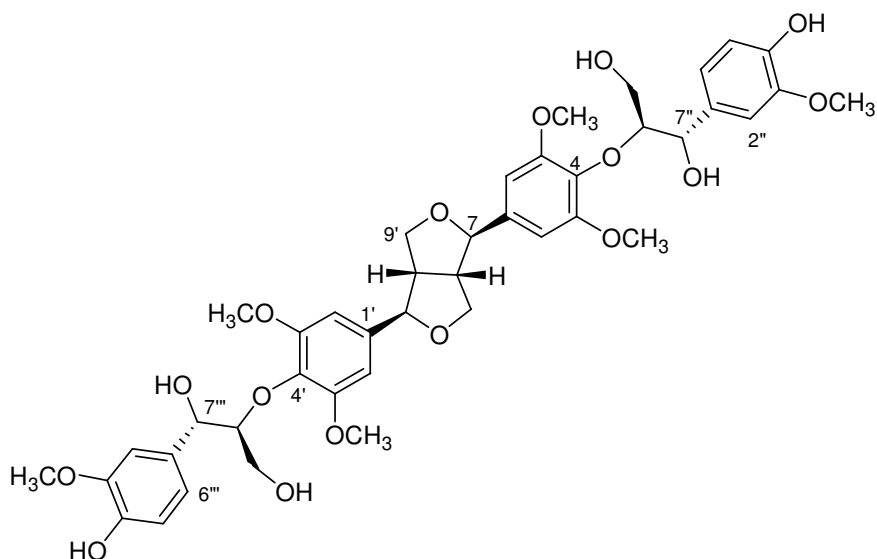

11

Compound **12** has been isolated for the first time. It had molecular formula $C_{31}H_{36}O_{11}$ according to the molecular ion peak at m/z 607 $[M+Na]^+$ in the MALDI MS spectrum. The ^{13}C and 1H NMR spectra show the presence of one aromatic ring with three coupled protons in a ABX spin system, and two aromatic rings, each one with two *meta* coupled protons. The presence of a *trans* double bond is confirmed by 1H NMR spectrum [δ_H 6.51 (d, $J=15.8$ Hz) and 6.25 (dt, $J=15.8, 5.8$ Hz)]. The COSY spectrum enables us to define a glycerol moiety as C7''–C9'' [δ_H 4.99 (d, $J=4.5$ Hz) H-7'', 4.10 (m) H-8'' and 4.00 (m) H-9''a, 3.50 (dd, $J=11.0, 2.0$ Hz) H-9''b] and a neolignan with a benzofuran ring C7'–C9' [δ_H 5.65 (d, $J=8.5$ Hz), 3.67 (m) and 3.92 (obscured)]. In accordance with the *erythro* relative configuration, the coupling value of 4.5 Hz between H-7'' and H-8'' has been observed.

These data resemble that of the aglycone of alangisesquin A isolated from *Alangium premnifolium* (Kuima *et al.* 1998) and buddlenol B isolated from *Buddleja davidii* (Houghton *et al.* 1985).

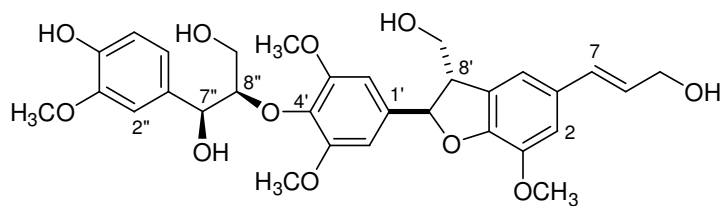

12

Compound **13** has never been isolated previously. It reveals a $[M+Na]^+$ peak at m/z 579 in the MALDI MS spectrum, suggesting the molecular formula, $C_{30}H_{36}O_{10}$.

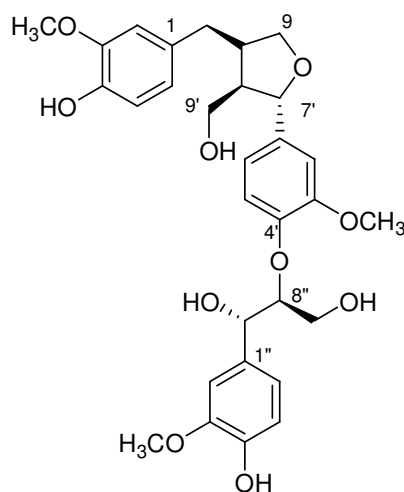

13

The ^{13}C NMR spectrum of **13** shows 27 carbon signals, and three methoxyl signals, indicating **13** to be a sesquiterpene. The 1H NMR and 1H - 1H COSY spectra show the presence of three sets of ABX patterns in the aromatic region, a glycerol moiety and a tetrahydrofuran ring. The DEPT experiment defines the carbons as three methyls, four methylenes, fourteen methines and nine quaternary carbons. The HMQC experiment allows the protons to be assigned to the corresponding carbons.

The connection of functional groups has been determined on the basis of HMBC correlations. All NMR data resemble those reported by *Yoshikawa et al. (1995)* for the ehletianol B.

Careful analysis of fragmentations of the molecular ion (fig.2), in the MALDI/MS, shows peaks at m/z 561 $[M+Na-H_2O]^+$ (18%), 549 $[M+Na-CH_2O]^+$ (10), 531 $[M+Na-H_2O-CH_2O]^+$ (37) and 382 $[M+Na-guaiacylglycerol]^+$ (100). The significant relative abundances of peaks at m/z 412 $[M+Na-CH_2O-C_8H_9O_2]^+$ and 342 $[M+Na-C_{13}H_{17}O_4]^+$ indicates the presence of a guaiacylglycerol unit at *O*-4' instead of the isomeric structure with this unit at *O*-4 as reported for ehletianol B, which has different pattern of fragmentation.

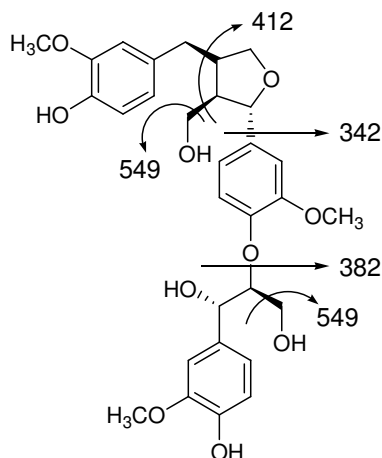
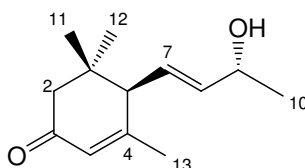

fig.2- MALDI/ MS fragmentation of compound **13**

Compound **14** has been identified as (6*R*,7*E*,9*S*)-9-hydroxy-4,7-megastigmadien-3-one. ESI-MS spectrum shows a molecular ion peak at m/z 208, in accordance with a molecular formula $C_{13}H_{20}O_2$. The ^{13}C NMR spectrum has thirteen signals that a DEPT experiment allows us to assign to five methinic carbons, four methyls, one methylene

and three quaternary carbons. The signal at δ 199.0 is typical of a α,β -unsaturated carbonyl carbon. The carbons of the conjugated double bond resonate at δ 161.7 (C-5) and 126.6 (C-4), while carbons of a second double bond give resonances at δ 138.5 (C-8) and 125.7 (C-7). Carbons to protons correlation is performed by means of an HMQC experiment.



14

Protonic resonances confirm the presence of two olefinic systems and an alcoholic function. The two protons H-2 resonate as large doublet ($J=17.0$ Hz) at δ 2.34 and 2.08. A COSY experiment defines the correlation between H-6 (δ_{H} 2.52)/ H-7 (δ_{H} 5.53)/ H-8 (δ_{H} 5.67)/ H-9 (δ_{H} 4.35)/ H-10 (δ_{H} 1.30), whose chemical shifts define the side chain as 3-hydroxybutenilic type. Other methyl resonances are at δ_{H} 1.90 (H-13), δ 1.03 (H-11) and δ 0.97 (H-12). Optical rotation of compound **14** is $+200^\circ$, which compared to literature values leads us to assign the configuration *6R*, *9S* to the chiral centres (*Fraga et al.1995*).

Compound **15** has been isolated for the first time, and has been identified as (3*S*,4*R*,7*E*,9*S*)-3,4,9-trihydroxy-5,7-megastigmadiene. Its EI MS shows the molecular ion peak at m/z 226, which is in good agreement with the molecular formula of a bis-*nor*-sesquiterpene $\text{C}_{13}\text{H}_{22}\text{O}_3$. In the ^1H NMR spectrum (Table 1) are present three methyls at δ 1.04, 1.06 and 1.84 as singlets, one methyl doublet at δ 1.26, two methylene protons as two double doublets at δ 1.80 and 1.43, three methine protons

geminal to hydroxyls as a double triplet at δ 3.75, a doublet at δ 3.85, and a quintuplet at δ 4.30, and two olefinic protons as a double doublet at δ 5.55 and a doublet at δ 6.03.

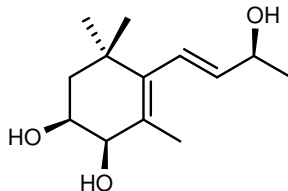

15

The ^{13}C NMR spectrum (Table 1) shows 13 carbon signals, identified, by a DEPT experiment, as four methyls, one methylene, five methines and three quaternary carbons. All the carbons are correlated to the corresponding protons on the basis of the HMQC experiment. The COSY experiment shows a correlation series beginning with the methine carbinol at δ 4.30, assigned to H-9, which is coupled with the doublet methyl at δ 1.26 assigned to H-10, and with the H-8 olefinic proton at δ 5.55. This latter proton is correlated with the H-7 proton at δ 6.03. The signal at δ 3.75 is correlated to the proton at δ 3.85, and also with the methylene protons at δ 1.80 and 1.43. Two hydroxyls are positioned at the C-3 and C-4 on the basis of the HMBC and NOESY experiments. The correlations of the H-4, H-8 and H-13 protons with the C-6 carbon and those of H-13 protons with C-4 carbon and C-5 carbons confirm the assumed structure. The analysis of the NOESY spectrum evidences NOE between the H-13 methyl and H-4 proton. The *cis* relative configuration at C-3 and C-4 is predicted on the basis of the small coupling constant $^3J_{\text{H3H4}}$ (1.8 Hz).

Table 1. NMR data for compound **15** and MPTA derivatives^a

C	15			15 R-MPTA		15 S-MPTA
	δ_C	DEPT	δ_H	HMBC	δ_H	δ_H
1	38.2	C		2, 3, 11, 12		
2	42.1	CH ₂	1.80 dd (12.5,12.0)	4, 6, 11, 12	2.12 dd(12.5,12.0)	1.95dd (12.5,12.0)
			1.43 dd(12.5, 3.0)		1.62 dd (12.5, 3.0)	1.59 dd (12.5, 3.9)
3	68.4	CH	3.75 dt (12.0, 3.0)	2, 4	5.22 dt (12.0, 3.0)	5.19 dt (12.0, 3.9)
4	73.1	CH	3.85 d (3.0)	2, 3, 6, 13	4.06 d (3.1)	4.17 d (4.1)
5	129.4	C		4, 7, 13		
6	142.9	C		2, 4, 8, 11, 12, 13		
7	127.3	CH	6.03 d (16.0)	9, 10	6.10 d (15.5)	6.19 d (16.0)
8	141.0	CH	5.55 dd (16.0, 6.5)	9, 10	5.45 dd (15.5, 6.0)	5.54 dd (16.0, 6.5)
9	69.9	CH	4.30 qn (6.5)	7, 8, 10	5.62 qn (6.0)	5.64 qn (6.5)
10	24.3	CH ₃	1.26 d (6.5)	9, 8	1.46 d (6.0)	1.42 d (6.5)
11	30.8	CH ₃	1.04 s	2, 6	1.00 s	1.00 s
12	28.2	CH ₃	1.06 s	2, 6	1.09 s	1.12 s
13	20.3	CH ₃	1.84 s	4, 6	1.75 s	1.81 s

^aValues were recorded at 500 MHz for ¹H and 125 MHz for ¹³C in CD₃OD for **15** and CDCl₃ for MPTA derivatives with J values in Hz in parentheses.

The absolute configurations at the carbinol carbons have been established by Mosher's method (*Dale et al. 1973*) converting compound **15** into the diastomeric MPTA triesters. Comparison of the chemical shifts of the signals due to H-8 and H-10 protons in both the *R* and the *S* derivatives and the calculation of the corresponding differences, expressed as $\Delta\delta_{R-S}$, are in agreement with a *S* configuration for C-9. The negative and positive $\Delta\delta_{R-S}$ values for the H-4 and H-2 protons, respectively, indicate an *S* configuration for C-3. For the C-4 carbon, a positive $\Delta\delta_{R-S}$ for the H-3 and a negative

value for H-13 have been found, indicating an *R* configuration for C-4 (*Othani et al. 1991*).

Compound **16** has been identified as (6*R*,7*E*,9*R*)-6,9-dihydroxy-4,7-megastigmadien-3-one, known as *Blumenol A*, by comparing the spectroscopic data with those reported in the literature (*Weiss et al. 1973*). The ESI MS spectrum shows a molecular ion peak at *m/z* 224 in accordance with a molecular formula C₁₃H₂₀O₃. The signal at δ 199.0 in the ¹³C NMR is indicative of a carbonyl carbon of an α,β -unsaturated system. The other twelve signals in the spectrum are attributed, by a DEPT experiment, to three olefinic methines, four methyls, one methylene, and three quaternary carbons.

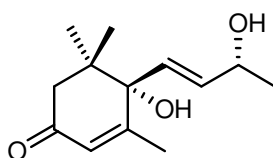

16

Proton correlation experiments define the presence of a 3-hydroxybutenyl chain: H-7 (δ 5.78), H-8 (δ 5.84), H-9 (δ 4.41) and H-10 (δ 1.30). Complete structure is assigned by considering the remaining protons and carbons resonances correlated through HMQC experiment. The 6*R* configuration is defined by the CD (MeOH) spectrum, which shows $\Delta\epsilon_{241\text{nm}} + 9.3$, $\Delta\epsilon_{319\text{nm}} -0.7$. The *R* configuration at C-9 is confirmed by Mosher's method. The Mosher derivative obtained by the reaction of compound **16** with (S)-(+)-MPTA-Cl, in the ¹H NMR spectrum, shows the following resonances of the protons adjoining the C-9: H-10 at δ 1.39 and H-8 at δ 5.88. The diastereoisomeric derivative of the (R)-(-)-MPTA-Cl, in the ¹H NMR spectrum, shows the signal of H-10 at δ 1.43 and H-8 at δ 5.77. Chemical shift difference between H-10 resonances in each Mosher derivative is -0.04, while for H-8 it is +0.11. These values allow an *S* configuration to

be assigned to the chiral centre C-9. The optical rotation measured for compound **16** is $[\alpha]_D^{25} +50.9$.

Compound **17** has been identified as (3*S*,5*R*,6*R*,7*E*,9*R*)-5,6-epoxy-3,9-dihydroxy-7-megastigmenone. The $^1\text{H-NMR}$ spectrum shows the signals of two olefinic protons at δ 5.90 (H-7) and 5.76 (H-8), two alcoholic protons at 4.38 (H-9) and 3.89 (H-3), four methyls and two methylene groups.

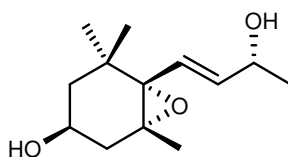

17

A COSY experiment correlates protons H-2 (δ 1.60 and 1.37), H-3 (δ 3.89), H-4 (δ 2.36 and 1.60). ^{13}C NMR signals are indicative of the presence of an epoxy-system condensed at the cyclohexane ring (69.5/ C-6, 66.3/ C-5), while an HMBC experiment confirms the carbon skeleton. These spectroscopic data are in agreement with those reported by *D'Abrosca et al. (2004)* for *nor*-terpenes isolated from *Cestrum parqui*.

Compound **18** reveals an $[\text{M}+\text{Na}]^+$ peak at m/z 409 in the MALDI MS spectrum, suggesting the molecular formula of $\text{C}_{19}\text{H}_{30}\text{O}_8$. The ^1H and ^{13}C NMR spectra show the presence of a β -glucopyranosyl unit and an aglycone moiety consisting of 13 carbon atoms.

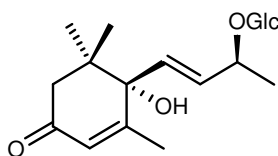

18

The α,β -unsaturated system is revealed by the following signals of the ^{13}C NMR experiment: δ 201.3 (C-3), 127.3 (C-4), 167.1 (C-5), which also presents the resonances of two alkenic carbons (δ_{C} 134.2 and 134.0), four methyls, a methylene, a methine, and the typical pattern of a glucopyranosyl system. These spectroscopic data suggest that **18** has the same skeleton as *corchoinoside C* previously isolated from *Corchorus olitorius* L. (Yoshikawa et al. 1997).

Malva silvestris

The young leaves and shoots of *Malva silvestris* have been eaten since the 8th century BC. The plant's many uses gave rise to the Spanish adage "A kitchen garden and mallow, sufficient medicines for a home". The flowers and leaves are emollient and beneficial for sensitive areas of the skin. It is applied as a poultice to reduce swelling and draw out toxins.



fig.3 *Malva silvestris*

Taken internally, the leaves reduce gut irritation and have a laxative effect. When common mallow is combined with eucalyptus (*Eucalyptus globulus*), it makes a good remedy for coughs and other chest ailments. For its properties as anti-inflammatory, emollient, astringent, and laxative it is widely used in phytotherapy.

Malva silvestris has a raised stem and can be 1 meter high. The leaves, with lobes indented in the edge, are dark green in color. The flowers have a characteristic tone, which goes from the crimson reddish to violet. The fruit is a capsule that contains reniform seeds. It is a spontaneous plant widely diffused in the Mediterranean area.

Fresh plants of *M. silvestris* has been extracted with water using Naviglio extractor (Naviglio 2003). This extractor is based on a suction effect, generated by a compression of an extracting solvent on solids at a pressure of about 8-9 bars for a determined time, and followed by an immediate decompression to the atmospheric pressure. Rapid release of the extracting liquid from the inside of a solid matrix, because of pressure gradient, mechanically transports the extractable compounds contained in the solid matrix towards the outside. The water extract was shaken with ethyl acetate and the organic fraction was purified by silica gel column and the fractions purified by preparative thin layer chromatography and HPLC yielding twenty-one compounds.

Compounds **19-29** share a common aromatic structure deriving from shikimic acid biogenetic pathway. Natural products deriving from shikimic acid range in complexity from the very simple, such as vanillin (used primarily as a flavoring agent), having a seven carbons skeleton, salicylic acid (the precursor of aspirin), lawsone (a naphthoquinone used in some sunscreens), and scopletin (a coumarin once used as a uterine sedative), to the more complex, such as lignans polymers. Compounds **30-36** are terpenoid derivatives, all biosynthesized from the mevalonic biogenetic pathway.

Compounds **19-23** have been identified as benzoic acid derivatives, compounds **24** and **27** as 4-hydroxybenzyl alcohol and tyrosol, compounds **25** and **26** as 4-hydroxy-dihydrocinnamic acid and 4-hydroxy-3-methoxy-dihydrocinnamic acid, and **28** and **29** as 4-hydroxy-cinnamic acid and ferulic acid by comparing their spectral data with those of authentic samples.

The ^1H NMR spectrum of compound **19** shows two large doublets in the aromatic area, each due to two protons H-2, H-6 and H-3, H-5, respectively. The ^{13}C NMR spectrum defines the presence of a carboxylic group and of a phenolic function. The IR spectrum has three main bands whose ν_{max} is at 3280, 3000 and 1600 cm^{-1} , confirming the aromatic and carboxylic functionalities. The spectroscopic data fit with those of 4-hydroxybenzoic acid.

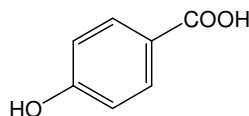

19

Compound **20** has an ^1H NMR spectrum very similar to that of compound **19**, but shows a further signal at δ 3.86 of a methoxyl group, whose carbon resonates at δ 56.0. The IR spectrum shows two significant bands having a ν_{max} at 3000 e 1710 cm^{-1} that can be attributed to the carboxylic system. All the spectroscopic data allow compound **20** to be identified as 4-methoxybenzoic acid.

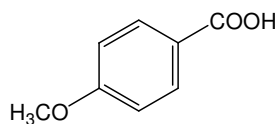

20

Compound **21** has, in the ^1H -NMR spectrum, the signals of an ABX spin system, which can be attributed to an aromatic ring 1,2,4-trisubstituted. The ^{13}C NMR shows the presence of a carboxylic moiety and of a methoxyl. Mass spectrum has a molecular ion peak at m/z 152, which is in agreement with a molecular formula $\text{C}_8\text{H}_8\text{O}_3$. These data establish compound **21** as 4-hydroxy-3-methoxy benzoic acid (*Della Greca et al., 2001*).

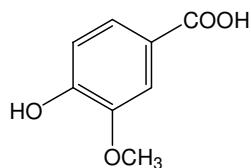

21

Compound **22** has its molecular ion peak, in a EI/MS experiment, at m/z 138, in accordance with a molecular formula $\text{C}_7\text{H}_6\text{O}_3$, while the ion peak at m/z 94 $[\text{M}-\text{CO}_2]^+$ can be attributed to the loss of a CO_2 molecule. The ^1H NMR spectrum has a pattern of signals typical of an *ortho* substituted aromatic ring, that resonates as six signals in the ^{13}C NMR spectrum. This experiment also confirms the presence of a carboxylic function. Chemical shift values identify the other functionality on the aromatic ring as an hydroxylic group. Compound **22** is thus identified as a 2-hydroxybenzoic acid.

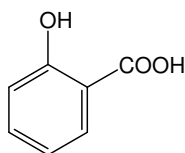

22

Compound **23** has been identified as a 4-hydroxy-2-methoxy benzoic acid. The ^1H NMR spectrum shows the signals of an aromatic ring *ortho-para* disubstituted (δ_{H} 7.57_d, 7.49_{dd} and 6.75_d) having protons resonances typical of a benzoic acid derivative. A NOE experiment allows the methoxy group resonating at δ 3.89 to be located in *ortho* position relative to the benzoic functionality. The molecular ion peak at m/z 152 in a EI MS spectrum agrees with the assigned structure having a molecular formula $\text{C}_8\text{H}_8\text{O}_3$. The mass spectrum also shows a peculiar peak at m/z 108, indicative of the loss of a CO_2 moiety.

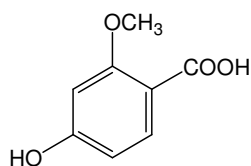

23

Compound **24** has a molecular ion peak in a EI-MS spectrum at m/z 124, which suggests a molecular formula $\text{C}_7\text{H}_8\text{O}_2$. The mass spectrum also shows ion peaks at m/z 107 $[\text{M}-\text{OH}]^+$ and m/z 93 $[\text{M}-\text{CH}_2\text{OH}]$. The IR spectrum shows a significant band at ν_{max} 3300 cm^{-1} , due to O-H stretching motions.

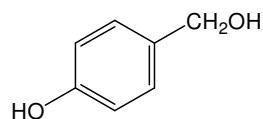

24

The ^1H NMR spectrum has a pattern of signals typical of a 1,4 disubstituted aromatic ring, and a singlet at δ 4.86 attributable to two protons of a benzyl alcohol moiety. The

^{13}C NMR spectrum has four signals in the aromatic area (δ_{C} 133.5/ C-1, 128.7/ C-2 and C-6, 115.9/ C-3 and C-5, 156.2/ C-4), and the signal of a benzyl carbon at δ 68.5. These data allow compound **24** to be identified as 4-hydroxybenzyl alcohol.

Compound **25** has been identified as 4-hydroxy-dihydrocinnamic acid. The ^1H NMR spectrum has four signals, two in the aromatic area, typical of a *ortho-para* disubstituted ring, and two generated by two protons each, at δ 2.80 and 3.11. Signal multiplicity indicates the latter protons are mutually coupled in an A_2X_2 spin system typical of an ethylic chain. The ^{13}C NMR spectrum has the signal of a carboxylic function at δ 177.1 and a quaternary carbon resonates at δ 154.8, indicating a phenolic structure.

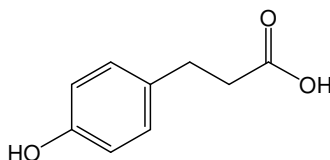

25

Compound **26** is identified as 4-hydroxy-3-methoxy-dihydrocinnamic acid. The ^{13}C NMR spectrum has ten signals, attributed by a DEPT experiment to four quaternary carbons, three methines, two methylenes and one methyl.

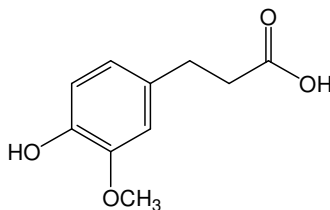

26

The resonances at δ 178.9, 146.4 and 144.0 are typical of a carboxylic group and of two oxygenated aromatic carbons, respectively. Protons resonances in a ^1H NMR spectrum indicate a 1,2,4-trisubstituted aromatic ring, a propanoic side chain, and a methoxy function. The assigned structure is confirmed by comparison with literature data (D'Abrosca *et al.* 2004).

Compound **27** has in the ^1H NMR spectrum two large doublets at δ 7.02 and 6.89 of a *para* substituted aromatic ring, and two triplets at δ 2.71 and 3.67 mutually coupled to an ethylic side chain. Chemical shift values suggest the presence of two hydroxyl groups that functionalize the aromatic ring and the side chain. According to these data a tyrosol structure is assigned to compound **27**.

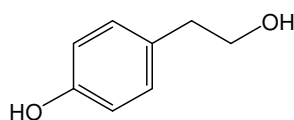

27

Compound **28** is identified as 4-hydroxy-cinnamic acid. The ^1H NMR spectrum has two large doublets (δ_{H} 7.60 and 6.30, $J=15.5$ Hz) of a *trans* disubstituted double bond, and two doublets of a *para* substituted aromatic ring (δ_{H} 7.44_d and 6.80_d, $J=8.0$ Hz). Literature data confirm the assigned structure (DellaGreca *et al.*, 2001).

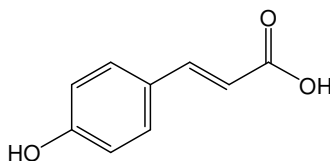

28

Compound **29** has been defined from the ^1H NMR data as ferulic acid. The protonic spectrum shows the signals of an ABX spin system attributed to a 1,2,4-trisubstituted aromatic ring, and two large doublets due to the olefinic protons of a *trans* disubstituted double bond. After comparison with a commercial sample we have uncertainly settled the structure of compound **29** (DellaGreca et al., 2001).

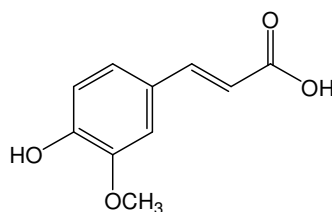

29

Compound **30** has been determined to be linalool. The EI MS has the ion peak at m/z 170, in accordance with a molecular formula $\text{C}_{10}\text{H}_{18}\text{O}_2$. Moreover the signal at m/z 152 $[\text{M}-\text{H}_2\text{O}]^+$ is generated by water loss. The IR spectrum mainly shows two absorption bands (ν_{max} at 3600 and 3420 cm^{-1}) caused by the stretching motions of a hydroxyl group. The ^{13}C NMR spectrum shows ten signals, that a DEPT experiment establishes as two methyls, four methylenes, two methines, and two quaternary carbons.

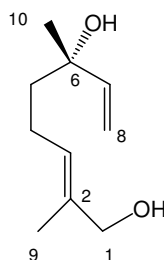

30

The ^1H NMR spectrum defines the presence of two olefinic systems, whose protons resonate at δ 5.42, 5.92, 5.22 and 5.08 respectively as a triplet and three double doublets. Furthermore the methylene protons H-1, H-4 and H-5 give resonances at δ 3.99, 2.10 and 1.55. Cross-peaks in a HMBC experiment correlate protons H-9 with the quaternary olefinic carbon at δ 134.9, and with the carbon at δ 125.7. In an HSQC experiment, this carbon is heterocorrelated to the olefinic proton at δ 5.42. The $^1\text{H}^1\text{H}$ COSY experiment correlates this proton to the signal at δ 2.10, which is coupled to protons at δ 1.55. The same experiment allows an ABX spin system typical of a vinyl group to be identified. The protons of this group are correlated in the HMBC experiment to the quaternary carbon at δ 73.3, which is also correlated to protons H-10, H-4, H-5. Optical rotation measurement allows this compound to be identified as (2*E*,6*S*)-2,6-dimethyl-2,7-octadien-1,6-diol (Nicoletti *et al.* 1985).

Compound **31** is identified as linalool-1-oic acid. Ion peaks in the EI MS at m/z 184, 156 and 144 are respectively attributed to the molecular ion, to the fragmented molecule obtained from the loss of a vinyl moiety ($[\text{M}-\text{C}_2\text{H}_4]^+$) and the loss of a CO_2 moiety ($[\text{M}-\text{CO}_2]^+$). In the IR spectrum three peculiar bands are present; two are generated by stretching vibrations of an hydroxyl group at ν_{max} 3400 and 3050 cm^{-1} , and one is caused by the C=O asymmetric stretching of a carboxylic system at 1680 cm^{-1} . The ^1H NMR spectrum shows four olefinic protons at δ 6.84, 5.86, 5.20 and 5.06 identified as H-3, H-7, H-8a and H-8b respectively, two triplets at δ 2.20 and δ 1.62 attributed to H-4 and H-5, two singlets of the methyls H-9 and H-10 at δ 1.78 and δ 1.28. ^{13}C -NMR data show the presence of a carboxylic group, that in a HMBC experiment results correlated to protons H-3 and H-9. These data define the structure of linalool oxidised at C-1 (Nicoletti *et al.* 1985).

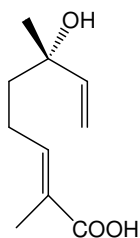

31

Compound **32** has been isolated for the first time. The EI MS of compound **32** shows a molecular ion peak at m/z 262, and prominent peaks at m/z 245 $[M-OH]^+$, 234 $[M-CO]^+$, and 219 $[M-C_3H_7]^+$. The molecular formula is identified as $C_{16}H_{22}O_3$ by EI MS. Its IR spectrum shows absorption bands of hydroxyl group (3300 cm^{-1}) and phenyl group (1600 cm^{-1}).

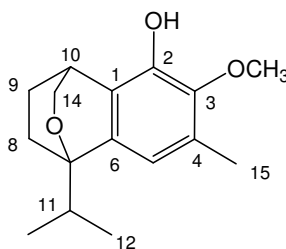

32

The structure of compound **32** has been established by using ^1H NMR and ^{13}C NMR including COSY, NOESY, HMQC, and HMBC experiments (Table 2). The ^1H COSY experiment shows a correlation series beginning with the methine at δ 2.43, assigned to H-11, which is coupled with the two methyls at δ 1.14 and 1.13. The proton signals at δ 4.00 and 3.45 assigned to methylene H-14 are correlated with the H-10 proton at δ 3.45, which is coupled with the H-9 protons at δ 1.97 and 1.49. These methylene protons are correlated with H-8 at δ 2.12 and 1.30. Present also in the ^1H NMR are three singlets attributed to two methyls and a methine.

Table 2. NMR spectral data of compound **32** in CDCl₃

Position	$\delta_{\text{H}}^{\text{a}}$	NOESY	δ_{C}	HMBC ^b
1			125.1 (q) ^c	
2			142.9* (q)	
3			144.0 (q)	
4			127.0(q)	
5	6.69 <i>s</i>	12, 13, 15	115.8 (t)	1, 3, 7
6			139.5 (q)	
7			74.7 (q)	
8	2.12 <i>m</i> , 1.30 <i>m</i>		27.3 (s)	6, 7, 9
9	1.97 <i>m</i> , 1.49 <i>m</i>		23.6 (s)	1
10	3.45 <i>m</i>		27.8 (t)	2, 6
11	2.43 <i>q</i> (6.8)		31.2 (t)	6, 7, 12, 13
12	1.14 <i>d</i> (6.8)	5	18.5 (p)	7, 11
13	1.13 <i>d</i> (6.8)	5	17.8 (p)	7, 11
14	4.00 <i>dd</i> (8.3, 2.4), 3.45 <i>m</i>		67.9 (s)	1, 7, 9, 10
15	2.32 <i>s</i>	5, 12, 13, OMe	16.1 (p)	3, 4, 5
OMe	3.81 <i>s</i>	15	60.7 (p)	3

^a ¹H chemical shift values (δ ppm from SiMe₄) followed by multiplicity and then the coupling constants (J in Hz). ^b HMBC correlations from H to C. ^c Letters, p, s, t and q, in parentheses indicate, respectively, the primary, secondary, tertiary and quaternary carbons, assigned by DEPT.

The ¹³C NMR spectrum of **32** shows 16 carbon signals, which have been attributed by a DEPT experiment to four methyls, three methylenes, and three methines. An HMQC experiment allows the protons to be assigned to the corresponding carbons. The connection of functional groups is determined on the basis of HMBC correlations. In the HMBC spectrum the H-5 proton has been heterocorrelated to the C-1, C-3, and C-7. The methoxy group at δ 3.81 and the methyl at δ 2.32 are also heterocorrelated to the C-3. The multiplet at δ 3.45 (H-10) gives correlations with aromatic carbons C-2, and C-6.

The methylene H-14 gives heterocorrelations to C-1, C-7, C-9, and C-10. These data completely define the structure of compound **32**. According to the structure, the analysis of NOESY spectrum evidenced NOEs of the methyls at δ 1.14 and 1.13, with the H-5 methine, and methyl at δ 2.32, and with the methoxyl at δ 3.81 (figure 4).



fig.4 Selected NOE of compound **32**.

Spectral data of compound **33** identify it as (+)-dehydrovomifoliol. The ^1H NMR spectrum shows two doublets at δ 6.46 and 6.83, which are attributed to two olefinic protons in an α,β -unsaturated system.

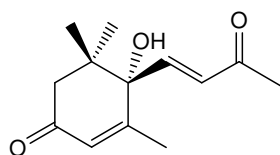

33

The coupling between H-7 and H-8 ($J=15.5$ Hz) assigns the *trans* configuration to the double bond. The singlet at δ 5.93 is due to the olefinic proton H-4, and the two large doublets at δ 2.58 and 2.27 ($J=17.4$ Hz) are attributed to the geminal protons H-2. The signals of four methyls are present at δ 2.29, 1.88, 1.09, 1.01. Comparison with literature data (*Mori et al. 1974*) confirms the structure assumed and defines the absolute stereochemistry.

Compound **34** is defined to be (3*R*,7*E*)-3-hydroxy-5,7-megastigmadien-9-one. The ^{13}C NMR spectrum shows thirteen signals attributed through a DEPT experiment to four quaternary carbons, two methylenes, three methines and four methyls. Chemical shift values identify the presence of a carbonyl carbon conjugated in α and γ , and of a carbinol carbon.

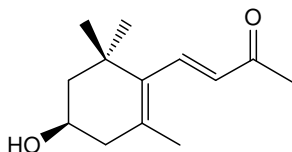

34

The $^1\text{H}^1\text{H}$ COSY experiment correlates the alcoholic proton at δ 4.05 to the double doublets of protons H-2 (δ 1.80 and 1.49) and H-4 (δ 2.44 and 2.08). The HMBC experiment confirms carbon skeleton and functionality positions (*Della Greca et al. 2004*).

Spectra data of compound **35** allow the structure of the (3*S*,5*R*,6*R*,7*E*,9*R*)-3,5,6,9-tetrahydroxy-7-megastigmene to be assigned. The ^1H NMR and COSY experiments define the presence of a 3-hydroxy butenilic chain through the correlations of the

protons H-7 (δ 5.90)/ H-8 (δ 5.66)/ H-9 (δ 4.28)/ H-10 (δ 1.22). Proton and carbon resonances define the presence of a cyclohexane ring having three hydroxyl functions in positions C-3, C-5 and C-6. HMBC experiment confirms the assigned structure through the correlations C-6/ H-8 and H-9, C-4/ H-2 (*D'Abrosca et al. 2004*).

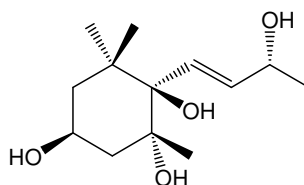

35

Compound **36** shows a molecular ion peak at m/z 340, and peaks at m/z 325 $[M-CH_3]^+$, 322 $[M-H_2O]^+$, and 297 $[M-C_3H_7]^+$. The molecular formula has been determined as $C_{20}H_{36}O_4$ by EI MS and ^{13}C NMR. The four oxygen functions have been ascribed to two secondary hydroxyl groups (δ_H 3.93 and 3.23, δ_C 79.2 and 79.5) and the remaining two have been attributed to tertiary hydroxyl groups (δ_C 74.3).

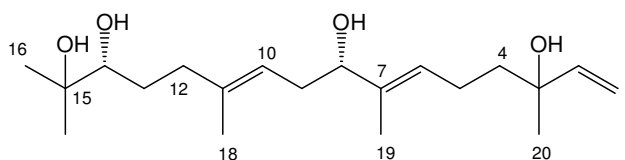

36

The structure of **36** has been characterized by 1H NMR and ^{13}C NMR including COSY, NOESY, HMQC, and HMBC experiments. The 1H NMR spectrum of **36** shows five singlet methyls, ten aliphatic protons of five methylenes, and seven methines attributed to two carbinolic and five olefinic protons. The $^1H^1H$ COSY experiment shows

correlation of the olefinic methine at δ 5.94, assigned to H-2, with the H-1 methylene δ 5.16 and 5.03. The broad triplet at δ 5.34, assigned to H-6, is correlated with the H-5 methylene at δ 2.08, which is correlated to methylene H-4 at δ 1.52. The broad triplet at δ 5.16, assigned to H-10, is correlated with methylene H-9 at δ 2.24, which is correlated to the methine H-8 at δ 3.93. The double doublet at δ 3.23, assigned to H-14, is correlated to methylene H-13 (δ_{H} 1.70 and 1.34), which is correlated to methylene H-12 (δ_{H} 2.24 and 2.05).

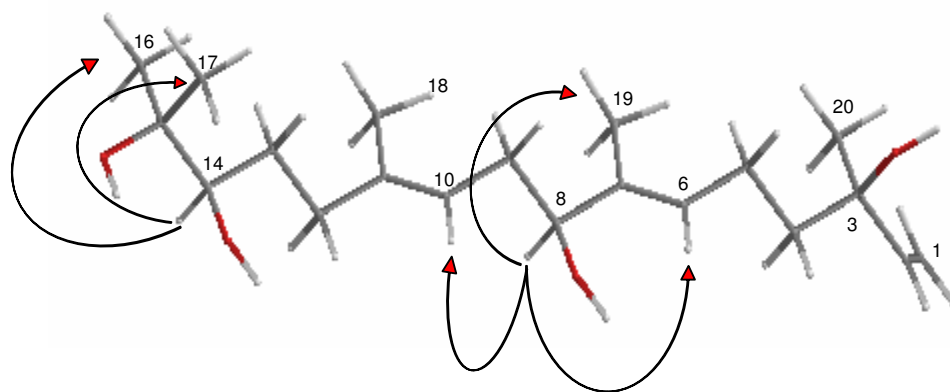

fig.5- Selected NOE of compound **36**

The ^{13}C NMR spectrum shows 19 carbon signals, identified, by a DEPT experiment, as five methyls, six methylenes, and five methines. All the carbons are correlated to the corresponding protons on the basis of an HMQC experiment. The tertiary hydroxyl groups have been positioned at C-3 and C-15 on the basis of an HMBC experiment that shows correlations between the C-3 carbon with the H-1, H-2, H-4 protons, and C-15 with the H-14, H-16, and H-17 protons.

Furthermore, NOESY correlations of H-8 with H-6, H-10, and H-19, and H-14 with H-16 and H-17 confirm the structure of diterpene **36**.

Table 3. NMR spectral data of compound **36** in CD₃OD

Position	$\delta_{\text{H}}^{\text{a}}$	NOESY	δ_{C}	HMBC ^b
1	5.19 <i>dd</i> 5.03 <i>dd</i> (17.0, 10.5, 1.5)		112.6 (s) ^c	2, 3
2	5.94 <i>dd</i> (17.0, 10.5)		146.7 (t)	3
3			74.3 (q)	
4	1.52 <i>dd</i> (8.0, 7.6)		43.5 (s)	2, 3, 5, 6, 20
5	2.08 <i>ddd</i> (8.0, 7.6, 7.0)		23.8 (s)	4, 6, 7
6	5.34 <i>brt</i> (7.0)	4, 8	127.9 (t)	4, 5, 8, 19
7			138.4* (q)	
8	3.93 <i>t</i> (6.8)	6, 10, 19	79.2 (t)	6, 7, 9, 10, 19
9	2.24 <i>m</i>		35.2 (s)	7, 8, 10, 11
10	5.16 <i>brt</i> (7.0)	8, 12	122.4 (t)	12, 18
11			138.2* (q)	
12	2.24 <i>m</i> , 2.05 <i>m</i>		38.5 (s)	10, 11, 13, 18
13	1.70 <i>m</i> , 1.34 <i>m</i>		31.2 (s)	12
14	3.23 <i>dd</i> (10.4, 2.0)	12, 16, 17	79.5 (t)	12
15			74.3 (q)	
16	1.16 <i>s</i>	14	25.5 (p)	14, 15, 17
17	1.15 <i>s</i>	14	26.1 (p)	14, 15, 16
18	1.63 <i>s</i>		16.9 (p)	10, 12
19	1.60 <i>s</i>	8	11.9 (p)	6, 7, 8
20	1.25 <i>s</i>		28.1 (p)	2, 3, 4

^a ¹H chemical shift values (δ ppm from SiMe₄) followed by multiplicity and then the coupling constants (J in Hz). ^b HMBC correlations from H to C. ^c Letters, p, s, t and q, in parentheses indicate, respectively, the primary, secondary, tertiary and quaternary carbons, assigned by DEPT.

The absolute configurations at the C-8 and C-14 secondary carbinol carbons have been established by Mosher's method, converting compound **36** into the diastomeric MTPA diesters. The chemical shift differences of protons, at β position of C-8 and C-

14 chiral carbons, has been assigned by $^1\text{H}^1\text{H}$ COSY experiment. The chemical shifts comparison of the signals due to H-9 and H-6/H-19 protons in both the *R* and the *S* MPTA derivatives and the calculation of the corresponding differences, expressed as $\Delta\delta_{R,S}$, are in agreement with an *S* configuration for C-8. For the C-14 carbon, the positive $\Delta\delta_{R,S}$ for H-16/H-17 and a negative value for H-13 have been found, indicating an *R* configuration for C-14. Therefore, the structure of **36** has been deduced to be (6*E*,8*S*,10*E*,14*R*)-3,7,11,15-tetramethylhexadeca-1,6,10-trien-3,8,14,15-tetraol.

The three *nor*-terpenes **14**, **16** and **17** isolated from the hydroalcoholic extract of *Brassica fruticulosa* have been also isolated from *Malva silvestris*.

Chenopodium album

Chenopodium album L. is an annual dicotyledonous belonging to Chenopodiaceae family, commonly known as lambsquarter. It is rich in iron and vitamin B1, and it is greatly used for edible purposes in Mediterranean countries and in North America, where it was one of the fundamental components of Indian diet. It is an infesting species of summer-autumn cultivations, easy to find in subcosmopolitan areas.

This plant has elliptical cotyledons with rounded tip, while the leaves are ovate or triangular, irregularly dentate. The adult plant reaches a height of 200 cm, with a simple or branched stem. Its flowers are small, greenish, grouped in whitish farinose, glomerules in panicle. Mallik *et al.* (1994) have reported the presence of growth inhibitory substances in this plant. They observed that the aqueous extract inhibited the germination and growth of radish and wheat seeds, attributing the activity to the presence of phenols. Horio *et al.* (1993) have reported the isolation of a phenolic amide with attractant activity toward zoospores of *Aphanomyces cochlioides*. We reinvestigated this plant to define its metabolites composition.



fig.6- *Chenopodium album*

Fresh plants of *Chenopodium album* were separated into leaves, twigs and roots, and the different parts were infused for 7 days into a hydroalcoholic solution (10% MeOH/H₂O) and four days in MeOH. The aqueous solution of hydroalcoholic extract of *C. album*, after acetone precipitation, was partitioned between methylene chloride and water. The methylene chloride extract was fractionated by silica gel column chromatography and the fractions purified by preparative TLC, DCCC and HPLC, yielding compounds **1**, **14**, **16**, **21**, **28**, **29**, **33**, **34**, **38**, **39**, **41-43**, **45**, **50**, **51**, **60-73**. The aqueous layer however, was fractionated by Amberlite XAD-2 and Sephadex LH-20 column chromatography to isolate compounds **4**, **37** and **49**. The aqueous solution of hydroalcoholic extract of *C.*

album twigs, after acetone precipitation and chromatographic purification led to the isolation of compounds **40**, **44**, **46**, and **48**. Compounds **37-51** (*Cuttillo et al. in press*) were identified as phenols derivatives and lignans, while compounds **60-73** were classified as *nor*-isoprenoids (*Della Greca et al. 2004*).

The methanol infusion of fresh plants of *Chenopodium album*, after removal of the solvent in vacuum, was suspended in water and precipitated with acetone. The supernatant was extracted with ethyl acetate and the organic layer separated into an acidic and a neutral fraction. The neutral portion was fractionated by silica gel column chromatography and the fractions were purified by preparative layer chromatography and HPLC yielding seven cinnamic amides **52- 58** (*Cuttillo et al. 2003*). Instead compound **59** was isolated from the MeOH extract of roots. The concentrated infusion was partitioned between EtOAc and H₂O. EtOAc-soluble materials were subjected to different silica gel column chromatographies and then purified by RP-18 HPLC to afford Chenoalbicin, which is a new molecule consisting of an alkaloid moiety linked to cinnamic acid amide (*Cuttillo et al. 2004*).

Compound **37** has been identified as cinnamic acid. ¹H NMR data define the presence of a monosubstituted aromatic ring, and of a double bond conjugated to a carboxylic function whose protons resonate at δ 7.61 and 6.41 as two doublets having a coupling constant typical of a *trans* configuration (J=15.5 Hz). ¹³C NMR spectrum confirms the presence of an unsaturated side chain containing a carboxylic group. Comparison with a commercial sample of cinnamic acid confirms the structure.

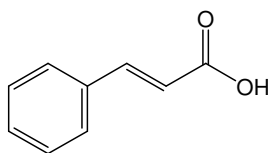

37

When we compared ^1H NMR data of compound **38** with those of compound **29** an extra signal related to a methyl group (δ_{H} 3.72) of an esteric function was detected. Compound **38** is therefore identified as methyl- (4-hydroxy-3-methoxy)cinnamate (*Bohlmann and Zdero, 1977*).

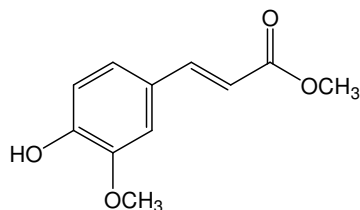

38

In the ^1H NMR spectrum compound **39** has a singlet in the aromatic area at δ 6.75 that integrates for two protons, and two doublets of a *trans* di-substituted olefinic system at δ 7.58 ($J=15.8$ Hz, H-7) and δ 6.28 ($J=15.8$ Hz, H-8). The signals of six protons belonging to two methoxyl groups are also present. These data identify compound **39** as 4-hydroxy-3,5-dimethoxycinnamic acid (*DellaGreca et al., 2001*).

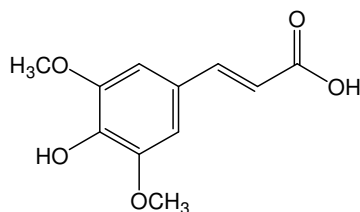

39

Compound **40** has a molecular ion peak in a EI MS experiment at m/z 210, while the base peak is at m/z 137 $[\text{M}-\text{CO}_2-\text{C}_2\text{H}_5]^+$. The assigned molecular formula is $\text{C}_{11}\text{H}_{14}\text{O}_4$. Two coupled triplets at δ 2.88 and 2.59 define the presence of an aliphatic ethyl, and the ABX spin system in the aromatic area is indicative of a 1,2,4 trisubstituted ring.

Two different methoxyl groups resonate at δ 3.88 and 3.80. ^{13}C NMR spectrum shows the presence of a carbonyl carbon of an esteric group. These data identify compound **40** as methyl 3-(4-hydroxy-3-methoxyphenyl)-propanoate (*Takayuki et al., 1993*).

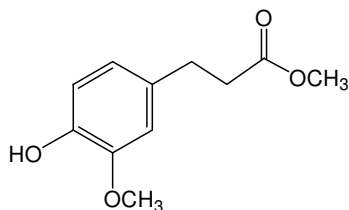

40

Compound **41** in a EI MS spectrum has a molecular ion at m/z 168, in accordance with a molecular formula $\text{C}_9\text{H}_{12}\text{O}_3$. The ^{13}C NMR spectrum shows nine signals, attributed on the basis of a DEPT experiment to four methines, two methyls, three quaternary carbons.

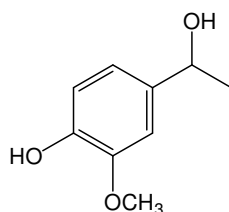

41

In the ^1H NMR spectrum, the signals of a 1,2,4-trisubstituted aromatic ring are present. The quartet of a proton at δ 4.68, coupled to a doublet at δ 1.49 due to three protons, suggests the presence of an ethanolic chain. These spectra data allow compound **41** to be identified as 4-(1-hydroxyethyl)-2-methoxyphenol (*Carro et al., 1995*).

Compound **42**, in a EI MS spectrum, has a molecular ion at m/z 168, according to a molecular formula $\text{C}_9\text{H}_{12}\text{O}_3$. The ^1H NMR spectrum has two coupled triplets at δ 4.00

and 3.18 of an aliphatic C₂ chain, a singlet at δ 3.95 of a methoxyl group, and, in the aromatic area of the spectrum, the signals of an ABX spin system attributed to a 1,2,4-trisubstituted benzene. These spectral data identify compound **42** as 2-(4-hydroxy-3-methoxyphenyl)-ethanol (*Della Greca et al., 2001*).

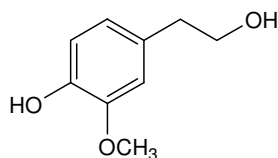

42

Compound **43** is identified as 4-hydroxy-3-methoxy-benzylic alcohol. The EI MS spectrum shows a molecular ion peak at m/z 154 according to a molecular formula C₈H₁₀O₃. In the aromatic area the ¹H NMR spectrum shows the signals of an ABX spin system that has been attributed to a 1,2,4-trisubstituted phenyl ring (δ 6.90_d H-5, 6.88_d H-2, 6.84_{dd} H-6). At higher field, two singlets of a methoxy group and of a benzylic methylene are present (δ 3.90_s 3-OMe, 4.60_s H-7).

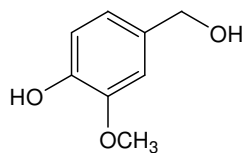

43

Compound **44** has a molecular ion peak in a EI-MS experiment at m/z 120, which suggests a molecular formula C₈H₈O. The ¹H NMR spectrum shows the signal of an ABX spin system at δ 5.59 (d, J=17.6 Hz, H-8a), 5.12 (d, J=10.8 Hz, H-8b) and 6.64 (dd, J=17.6 and 10.8 Hz, H-7) that is typical of a vinylic group. In addition two aromatic

doublets, integrated for two protons each, resonate at δ 7.29 and 6.78. The assigned structure is of *p*-hydroxystyrene (Teai *et al.*, 2001).

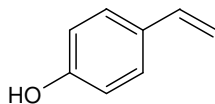

44

Compound **45** has the molecular ion peak in a EI MS spectrum at m/z 108 according to a molecular formula C₈H₈O. The ¹H NMR spectrum has the signal of a highly deshielded proton which resonates as a singlet at δ 9.95, indicative of an aldehydic function. The signals of a *para* substituted aromatic ring (δ_{H} 7.77_d and 7.32_d) and of a methyl (δ_{H} 2.43) are also present. These data identify compound **45** as 4-methylbenzaldehyde.

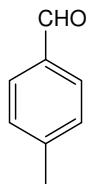

45

Spectra analysis univocally defines compound **46** as acetyl tryptamine. ¹³C NMR spectrum has twelve signals which are attributed, on the basis of a DEPT experiment, to five methins, two methylenes, one methyl and four quaternary carbons. Chemical shift values of both protons and carbons spectra are indicative of an indolic monosubstituted structure. The ¹H¹H COSY correlations suggest the presence of an ethyl chain, directly linked to a nitrogen atom. An amidic carbon resonates in the ¹³C

NMR at δ 170.7, and an acetyl carbon at δ 24.0. These data are indicative of a triptamine skeleton acetylated on the side chain (*Moro et al., 1975*).

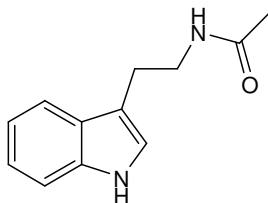

46

Compound **47** has the molecular ion peak in a EI MS spectrum, at m/z 418 according to a molecular formula $C_{22}H_{26}O_8$. The 1H NMR spectrum has the signals of a tetrasubstituted aromatic ring, and of a C_3 side chain.

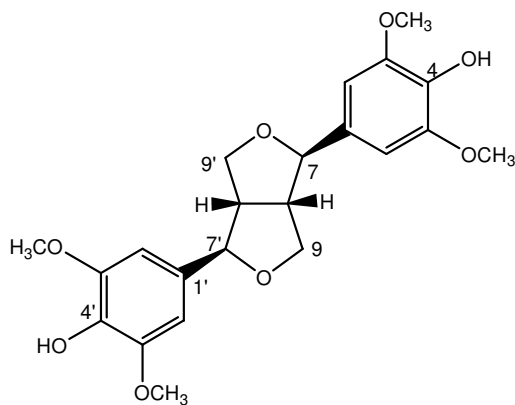

47

The latter in a $^1H^1H$ COSY experiment results consisting of a doublet at δ 4.72 scalarly coupled to a multiplet at 3.09, which, in turn, is correlated to two different multiplets at 4.26 and 3.61. These chemical shift data are typical of a dioxabicyclo octanic system. A

singlet integrated for twelve protons appears at 3.89. Spectral data univocally define compound **47** as (\pm)-syringaresinol (*Briggs et al., 1968*).

Compound **48** is (\pm)-5,5'-dimethoxyariciresinol. The ^1H and ^{13}C NMR spectra have the signals of two aromatic rings tetrasubstituted, and of a furanic ring. The signals of a benzylic methylene and of an alcoholic methylene are also present. The ^1H - ^1H COSY experiment shows a correlation series beginning with the methine at δ 4.80, assigned to H-7', which is coupled with the methine at δ 2.73 (H-8'), that, in turn, is correlated to the methine at δ 2.43 (H-8) and the methylene protons at δ 3.80 (H-9'). In the same experiment H-8 is also correlated to the methylene protons H-7 (δ_{H} 2.93 and 2.54) and H-9 (δ_{H} 4.06 and 3.85). HMBC correlations confirm the structure and define the position occupied by the methoxy groups (*Kinjo et al., 1991*).

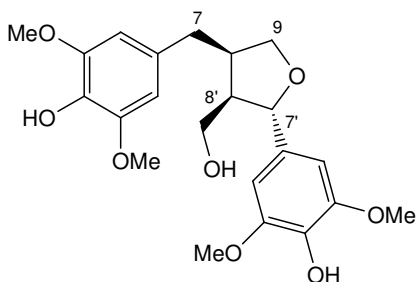

48

Sesquilignan **49** has been identified as *threo*-guaiacylglycerol- β -*O*-4-syringaresinol ether on the basis of its spectroscopic data. The ^1H and ^{13}C NMR spectra have the signals of three aromatic rings, two of them tetrasubstituted with the remaining protons in *meta* position, and one 1,2,4 trisubstituted. The resonances of protons H-7, H-8, H-9 and H-7', H-8', H-9' suggest the presence of a dioxabicyclo octanic system, which is confirmed both by carbon resonances and ^1H - ^1H COSY correlations. The correlated

protonic system δ 5.01/ 4.13/ 3.88/ 3.50 is typical of a glycerol moiety. HMBC correlations confirm the structure, and the correlation H-8''/ C-4' is significant in defining the guaiacylglycerol linking position.

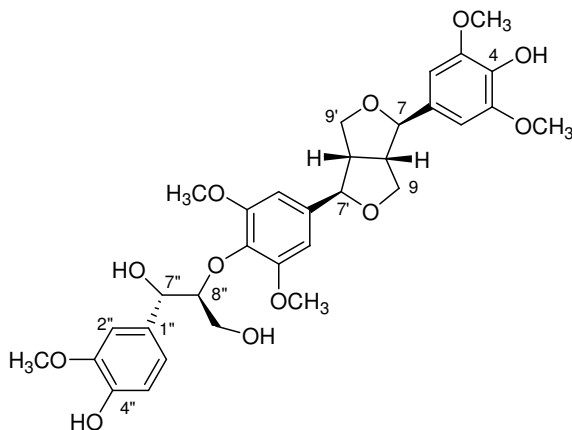

49

These data resemble that of *Buddlenol C* (Houghton, 1985) isolated as *erythro* and *threo* diastereoisomeric mixture. The absolute configurations at C-7'' and C-8'' of compound **49** are established on the basis of the CD spectroscopic data and coupling constant in the ^1H NMR spectrum. The coupling of 6.9 Hz between the H-7'' and H-8'' protons indicates a *threo* relative configuration, and the positive CD curve in the 210-260 nm range agrees with 7''*S*, 8''*S* configuration (Arnoldi *et al.*, 1985 and Fang *et al.*, 1992).

Compound **50** has been isolated for the first time. Its molecular formula $\text{C}_{33}\text{H}_{40}\text{O}_{12}$ has been assigned according to the molecular ion at m/z 628 $[\text{M}]^+$ in the ESI/MS spectrum. The ^1H NMR (Table 4) and COSY spectra reveal the connectivity of protons characteristic of the 3,7-dioxabicyclo [3.3.0] octane and the propane 1,2,3-triol groups. The COSY spectrum enables us to define a glycerol moiety as C-7''-C-9'' [δ_{H} 4.56 (d, $J=6.8$ Hz), 4.13 (m) and 3.80 (obscured), 3.52 (dd, $J=2.9$ and 11.7 Hz)]. In accordance with the *threo* relative configuration, the coupling constant value of 6.8 Hz between H-

$7''$ and $H-8''$ has been observed (Della Greca et al., 1994). Moreover the presence of one aromatic ring with three coupled protons in an ABX system, and two aromatic rings, each with two protons located at *meta* sites, are evident.

The ^{13}C NMR spectrum of **50** shows only 27 carbon signals, which, on the basis of a DEPT experiment, are attributed to six methyls, three methylenes, thirteen methines and eleven quaternary carbons.

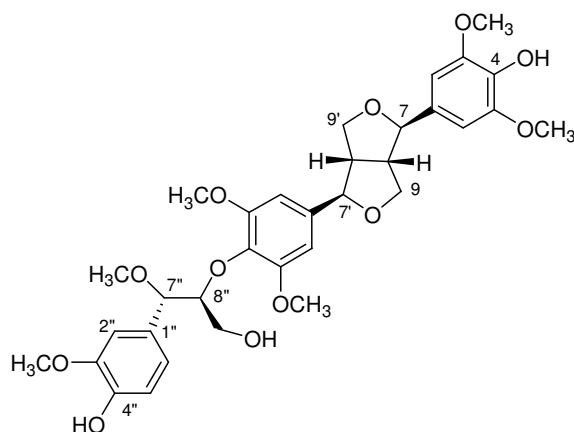

50

An HMQC experiment allows the protons to be assigned to the corresponding carbons. The connection of functional groups has been determined on the basis of HMBC correlations. In the HMBC spectrum the $H-7$ and $H-7'$ protons are heterocorrelated to the $C-2$ and $C-2'$ of the two tetrasubstituted aromatic rings and to the $C-8$, $C-9$ and $C-8'$, $C-9'$ of the furofuran lignan unit. The doublet at δ 4.56 attributed to $H-7''$ gives correlations with $C-1''$, $C-2''$, $C-6''$, $C-8''$, $C-9''$ and $\text{MeO}-7''$. These data completely define the structure of sesquilignan **50**.

According to the structure the analysis of NOESY spectrum evidences NOEs of the methoxyls at δ 3.82-3.86 with $H-2$, $H-6$, $H-2'$, $H-6'$ and $H-2''$, and of the methoxyl at δ 3.22 with $H-7''$. The *threo* relative configuration and the positive CD curve in the 210-260 nm range agree with $7''S$, $8''S$ configuration.

Table 4. NMR spectral data of compound 50 measured in deuterioacetone

Position	¹ H-NMR ^a	NOESY	¹³ C-NMR	HMBC(C) ^b
1			134.1 (C) ^c	
2	6.70 (<i>s</i>)	MeO-3, 7	104.5 (CH)	1, 3, 4, 7
3			152.8 (C)	
4			148.3 (C)	
5			152.8 (C)	
6	6.70 (<i>s</i>)	MeO-5, 7	104.5 (CH)	1, 4, 5, 7
7	4.67 (<i>d</i> , 3.9)	2, 6, 9	86.8 (CH)	2, 8, 9
8	3.09 (<i>m</i>)		55.2 (CH)	
9	4.24 (<i>dd</i> , 7.1, 15.0), 3.90 (obscured)		72.3 (CH ₂)	7, 8
1'			134.3 (C)	
2'	6.68 (<i>s</i>)	MeO-3', 7'	104.2 (CH)	4', 7'
3'			152.0 (C)	
4'			136.7 (C)	
5'			152.0 (C)	
6'	6.68 (<i>s</i>)	MeO-5', 7'	104.2 (CH)	4', 7'
7'	4.71 (<i>d</i> , 3.9)	2', 6', 9'	86.6 (CH)	2', 8', 9'
8'	3.09 (<i>m</i>)		55.4 (CH)	
9'	4.24 (<i>dd</i> , 7.1, 15.0), 3.90 (obscured)		72.3 (CH ₂)	7', 8'
1''			129.5 (C)	
2''	6.98 (<i>d</i> , 1.5)	MeO-3''	111.9 (CH)	4'', 6'', 7''
3''			148.5 (C)	
4''			146.9 (C)	
5''	6.81 (<i>d</i> , 7.5)		115.1 (CH)	1'', 3''
6''	6.84 (<i>dd</i> , 1.5, 7.5)		121.7 (CH)	4''
7''	4.56 (<i>d</i> , 6.8)		83.5 (CH)	1'', 2'', 6'', 8'', 9'', MeO-7''
8''	4.13 (<i>m</i>)		86.5 (CH)	
9''	3.80 (obscured), 3.52 (<i>dd</i> , 2.9, 11.7)		60.6 (CH ₂)	7''
MeO-3, 5	3.82 <i>s</i>	2, 6	57.4 (CH ₃) [*]	3, 5
MeO-3', 5'	3.84 <i>s</i>	2', 6'	56.8 (CH ₃) [*]	3', 5'
MeO-3''	3.86 <i>s</i>	2''	57.0 (CH ₃) [*]	3''
MeO-7''	3.22 <i>s</i>	7''	58.1 (CH ₃)	7''

^a¹H chemical shift values (δ ppm from SiMe₄) followed by multiplicity and then the coupling constants (J in Hz). ^b HMBC correlations from H to C. ^{*} Assignments may be interchanged.

Compound **51** has never been isolated before. It has molecular formula $C_{34}H_{42}O_{13}$ according to the molecular ion at m/z 658 $[M]^+$ in the ESI/MS spectrum. The ^{13}C and 1H NMR spectra show the presence of three aromatic rings, each with two protons, which are located at *meta* sites relative to each other. The COSY spectrum enables us to define a glycerol moiety as C-7''–C-9'' [δ 4.43 (d, $J=6.7$ Hz), 4.22 (m) and 3.90 (m), 3.70 (dd, $J=2.0, 11.0$ Hz)]. The coupling constant value of 6.7 Hz between H-7'' and H-8'' defines a *threo* relative configuration.

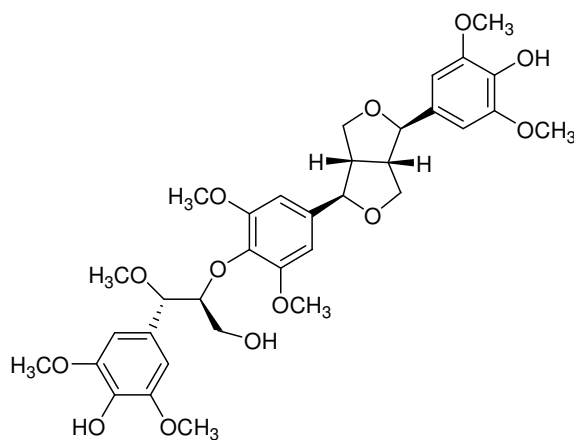

51

The ^{13}C NMR spectrum of **51** shows 23 carbon signals, and a DEPT experiment attributes the signals to seven methyls, three methylenes, twelve methines and twelve quaternary carbons. An HMQC experiment allows the protons to be assigned to the corresponding carbons. The connection of functional groups is determined on the basis of HMBC correlations. In the HMBC spectrum the H-7 and H-7' protons are heterocorrelated to the C-2 and C-2' of the two tetrasubstituted aromatic rings and to the C-8, C-9 and C-8', C-9' of the furofuran lignan unit. The doublet at δ 4.43 attributed to H-7'' gives correlations with C-1'', C-2'', C-6'', C-9'' and MeO-7''.

Table 5. NMR spectral data of compound 51 in deuteromethanol

Position	¹ H-NMR ^a	NOESY	¹³ C-NMR	HMBC (C) ^b
1			136.0 (C)	
2	6.62 (<i>s</i>)	MeO-3, 7	104.7 (CH)	1, 3, 4, 7
3			154.2 (C)	
4			148.9 (C)	
5			154.2 (C)	
6	6.62 (<i>s</i>)	MeO-5, 7	104.7 (CH)	1, 4, 5, 7
7	4.73 (<i>d</i> , 3.8)	2, 6, 9	87.7 (CH)	2, 8, 9
8	3.13 (<i>m</i>)		56.2 (CH)	
9	4.60 (<i>dd</i> , 7.0, 14.8), 3.90 (obscured)		73.4 (CH ₂)	7, 8
1'			135.0 (C)	
2'	6.66 (<i>s</i>)	MeO-3', 7'	105.0 (CH)	4', 7'
3'			154.0 (C)	
4'			138.2 (C)	
5'			154.0 (C)	
6'	6.66 (<i>s</i>)	MeO-5', 7'	105.0 (CH)	4', 7'
7'	4.73 (<i>d</i> , 3.8)	2', 6', 9'	88.1 (CH)	2', 8', 9'
8'	3.13 (<i>m</i>)		56.2 (CH)	
9'	4.60 (<i>dd</i> , 7.0, 14.8), 3.90 (obscured)		73.4 (CH ₂)	7', 8'
1''			131.1 (C)	
2''	6.58 (<i>s</i>)	MeO-3''	106.6 (CH)	4'', 6'', 7''
3''			150.2 (C)	
4''			146.0 (C)	
5''			150.2 (C)	
6''	6.58 (<i>s</i>)		106.6 (CH)	4''
7''	4.43 (<i>d</i> , 6.7)		84.5 (CH)	1'', 2'', 6'', 9'', MeO-7''
8''	4.22 (<i>m</i>)		86.7 (CH)	
9''	3.90 (obscured), 3.70 (<i>dd</i> , 2.0, 11.0)		62.4 (CH ₂)	7''
MeO-3, 5	3.80 <i>s</i>	2, 6	57.3 (CH ₃) [*]	3, 5
MeO-3', 5'	3.81 <i>s</i>	2', 6'	57.1 (CH ₃) [*]	3', 5'
MeO-3'', 5''	3.84 <i>s</i>	2''	58.0 (CH ₃) [*]	3''
MeO-7''	3.77 <i>s</i>	7''	58.2 (CH ₃) [*]	7''

^a¹H chemical shift values (δ ppm from SiMe₄) followed by multiplicity and then the coupling constants (J in Hz). ^b HMBC correlations from H to C. * Assignments may be interchanged.

These data completely define the structure of sesquilignan **51**. According to the structure, the analysis of NOESY spectrum evidences NOEs of the methoxyls at δ 3.80-3.84 with H-2, H-6, H-2', H-6' and H-2'', H-6'' and methoxyl at δ 3.77 with H-7''. The *threo* relative configuration and the positive CD curve in the 210-260 nm range agrees with 7''*S*, 8''*S* configuration.

Compounds **1**, **4**, **21**, **28** and **29** already described as metabolic products of *Brassica fruticulosa* and *Malva sylvestris*, have been also found in *Chenopodium album*.

Compound **52** has been identified as an amidic compound constituted by a dopamine unit linked to a cinnamic acid derivative. It is known as *N-trans*-feruloyl 4'-*O*-methyldopamine, isolated previously by *Horio et al. (1993)*.

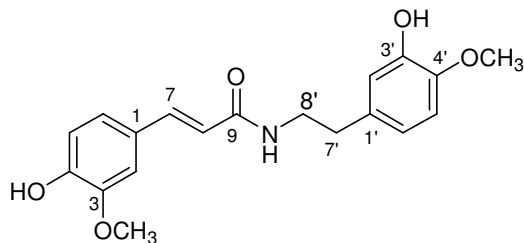

52

The ¹³C NMR shows nineteen signals that are attributed to two aromatic rings, a carbonyl of an α , β -unsaturated system, an ethylic chain, two methoxyls. The ¹H NMR shows the two rings as trisubstituted, having the protons coupled in a ABX spin system. H-7/ H-8 coupling defines the *trans* geometry of the double bond. Positions occupied by the two methoxy groups on the rings are defined by a NOESY experiment that shows

cross-peaks between the methoxy protons and the two protons H-2 and H-5', respectively.

Spectroscopic analysis of compound **53** has led to its identification as *N-trans-feruloyl 3'-O-methyldopamin*. This compound has already been isolated from *Spinacia oleracea* (Suzuki *et al.*, 1981). Molecular formula $C_{19}H_{21}O_5N$ is assigned from the molecular ion peak at m/z 343. The 1H NMR spectrum defines the presence of two aromatic rings, each having three protons of an ABX spin system. Two protons resonate as doublets at δ 7.44 and 6.41 with a coupling constant indicative of a *trans* double bond. Two triplets at δ 3.49 (2H, t, $J=7.1$ Hz, H-8') and 2.77 (2H, t, $J=7.1$, H-7') define the presence of an ethylic side chain. An HMQC experiment allows the protons to be assigned to the corresponding carbons. The ^{13}C NMR experiment shows the signal of a carbonyl carbon at δ 169.2, which in an HMBC experiment is heterocorrelated to protons H-7, H-8. Long-range couplings also allow the methoxyl positions to be assigned.

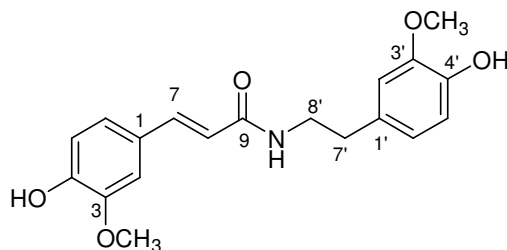

53

Compound 54 has the molecular ion peak of a EI-MS spectrum at m/z 313, which is indicative of the molecular formula $C_{18}H_{19}O_4N$. The 1H NMR spectrum shows the signals of two aromatic rings having protons coupled in a ABX and an AA'XX' spin system, respectively. The $^1H^1H$ COSY spectrum correlates the signals of the olefinic proton H-7 to H-8, and of the two protons of the methylene group H-7' to the two H-8'.

Spectral data reveal the presence of one methoxyl group assigned through an HMBC experiment to position C-3. Long-range heteronuclear correlations also indicate the presence of an α - β unsaturated system. These data agree with the ones reported by *Hussain et al. (1982)* for the *N-trans-feruloyl tyramine* isolated from *Hypocoum* sp.

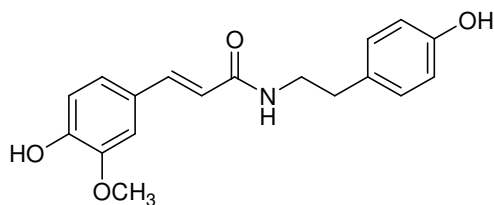

54

Compound **55** has a molecular ion peak at m/z 371 in a EI MS spectrum. This value suggests a molecular formula $C_{21}H_{25}O_5N$. ^{13}C NMR shows 17 signals that NMR experiments assign to two aromatic rings, an olefinic bond, an ethylic chain, a carbonyl and four methoxy groups. The two aromatic rings are defined as 1,2,4 trisubstituted on the basis of an 1H NMR experiment, besides functional groups correlation derives from an HMBC experiment, which also leads to the assignment of methoxyl positions. All these data allow compound **55** to be identified as *N-trans-4-O-methylferuloyl 3',4'-O-dimethyldopamine*, which has been described already by *Adesina et al. (1989)* in their studies of *Zanthoxylum rubescens*.

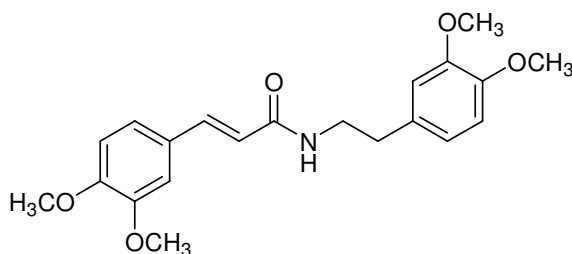

55

Table 6. ^{13}C NMR data of **52-58**

C	52 ^b	53 ^a	54 ^a	55 ^b	56 ^a	57 ^c	58 ^b
1	127.3	128.3	122.7	127.7	128.2	126.7	127.8
2	109.7	111.6	111.0	109.5	111.5	109.8	109.5
3	146.8	149.9	149.3	149.1	149.9	147.2	149.1
4	145.4	149.0	148.7	150.5	147.6	147.6	150.5
5	114.8	116.5	116.0	111.0	116.5	114.9	111.0
6	122.1	123.2	127.8	121.9	123.2	121.8	122.0
7	141.1	142.0	141.6	140.9	142.0	140.7	140.9
8	118.2	118.8	118.2	118.4	118.7	117.5	118.5
9	166.4	169.2	168.7	166.1	169.2	167.0	166.1
1'	132.1	132.1	130.8	131.4	133.5	111.9	132.1
2'	115.0	113.5	130.3	111.9	113.0	122.2	114.9
3'	145.4	149.3	115.8	149.1	149.3	111.1	145.7
4'	145.7	146.1	156.0	147.7	147.5	118.7	145.3
5'	110.9	116.2	115.8	111.3	116.4	121.4	110.9
6'	120.2	122.3	130.3	120.6	120.9	118.1	120.2
7'	34.9	36.2	35.9	35.1	36.0	24.9	35.0
8'	40.8	42.5	42.1	40.8	42.4	39.7	40.8
1a'						127.1	
3a'						136.2	
3-OMe	55.9	56.4	55.9	55.9		55.4	55.9
4-OMe				55.9	56.5		55.9
3'-OMe		56.4		55.9	56.5		
4'-OMe	56.0			55.9			55.9

^aCD₃OD ^bCDCl₃ ^cCDCl₃:CD₃OD (4:1).

Compound **56** in a ^1H NMR experiment has the signals of two aromatic rings 1,2,4 trisubstituted and of an olefinic bond with a *trans* geometry. The signals of two triplets integrated for two protons are indicative of an ethylic chain.

Two methoxy groups resonating at δ 3.83 and 3.89 are also present. The molecular formula deduced from the molecular ion peak, in a EI MS spectrum, at m/z 343, is C₂₁H₂₅O₅N. In the ^{13}C NMR spectrum the carbonylic function resonates at δ 169.2. Substituent positions derived from HMBC and NOESY experiments. This compound is

identified as *N-trans*-4-*O*-methylcaffeoyl 3'-*O*-methyldopamine. It is the first time this compound has been isolated from natural sources, though it has already been synthesized by *Tanaka et al. (1989)*.

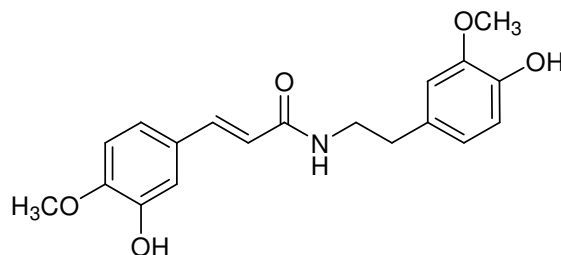

56

Compound **57** is defined to be *N-trans*-feruloyl tryptamine. This compound has been previously obtained by synthesis (*Ehmann, 1974*), but it is reported for the first time as natural compound. The molecular formula deduced from the EI-MS (m/z 336 $[M]^+$) is $C_{20}H_{20}O_3N_2$. The ^{13}C NMR has 20 signals, which are indicative of a tryptaminic system, a carbonyl belonging to an α,β unsaturated group, an aromatic ring, and a methoxyl. The signal at δ 39.7 is attributed through a DEPT experiment to a methylene carbon (C-8'), whose protons, correlated in an HMQC experiment, resonate at δ 3.56. The $^1H^1H$ COSY experiment shows H-8' correlated to H-7' (δ_H 2.92), while in a HMBC experiment the same H-8' give cross-peaks with C-1' and C-9. Long-range correlations are also observed between H-7' with C-1' and C-1'a.

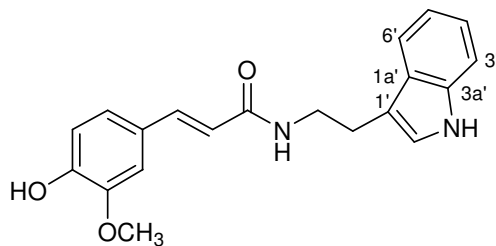

57

The indolic system resonates in the ^1H NMR spectrum in the aromatic range δ 6.90-7.70 overlapping the aromatic ring signals. HSQC and $^1\text{H}^1\text{H}$ COSY experiments allow proton resonances in this area to be assigned. The cross-peak between 3-OMe protons and H-2 in the NOESY experiment confirms methoxyl position.

Compound **58** has been identified as *N-trans-4-O-methylferuloyl 3'-O-methyldopamine*. It has been isolated for the first time. Its molecular formula is $\text{C}_{20}\text{H}_{23}\text{NO}_5$ according to the molecular ion at m/z 357 in its EI MS spectrum. The ^{13}C NMR spectrum (Table 6) shows the presence of only eighteen signals, with the methyls of three methoxyl groups having the same chemical shift.

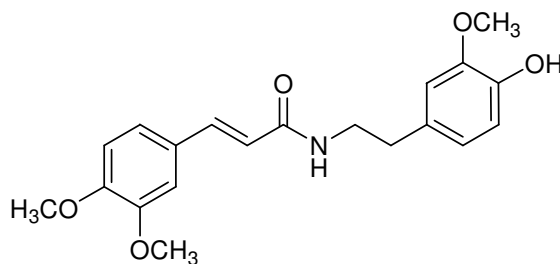

58

The DEPT experiment defines the carbons as three methyls, two methylenes, eight methines and seven quaternary carbons. In the ^1H NMR spectrum the H-2', H-5' and H-6' protons of the dopamine moiety are present as a narrow doublet, a large doublet and a double doublet at δ 6.84_d, 6.86_d and 6.76_{dd} respectively, while the H-2, H-5 and H-6 protons of the ferulic moiety are at δ 7.06_d, 6.90_d and 7.11_{dd}, respectively. Furthermore, the spectrum shows the H-7' and H-8' methylenes as two triplets at δ 2.79 and 3.62, respectively, and the H-7 and H-8 olefinic protons as two doublets at δ 7.60 and 6.25.

According to the structure, in a NOE experiment, the protons of the methoxyl group at δ 3.88 relate with the proton doublet at δ 6.84, and the protons of the methoxyls at δ 3.90 relate with the protons doublets at δ 7.06 and 6.90. Finally the HMBC experiment

evidences the following correlations: H-2' with C-4', H-5' with C-1' and C-3', H-6' with C-4' and C-7', H-8' with C-1', H-2 with C-4, H-5 with C-1 and C-3, H-6 with C-4 and C-7, H-7 with C-9 and, H-8 with C-1.

Compound **59** has been isolated for the first time. The name assigned is Chenoalbicin. It has a molecular formula $C_{36}H_{34}N_2O_7$ in accordance with the molecular ion at m/z 645 $[M+K]^+$ in its MALDI/MS spectrum. The ^{13}C NMR spectrum (Table 7) shows the presence of only thirty-one signals, including nineteen different aromatic carbons instead of the expected twenty-four signals. A close inspection of the 1H and ^{13}C NMR spectra of **59** (Table 7) by DEPT and HSQC experiments reveals the presence of the following functionalities: two carbonyl groups, four secondary sp^3 -carbons (C-7', C-8', C-5'' and C-6''), two aliphatic methines (C-13'' and C-13a''), two methyls (3-OMe and 4'-OMe), two methines (C-7 and C-8) of an olefine group, three trisubstituted and one disubstituted aromatic rings (C-1–C-6; C-1'–C-6'; C-9''–C-12'', C-8a'', C12a'' and C-1''–C-4'', C-4a'', C-1a''). The connection between these functional groups, determined on the basis of 1H - 1H COSY and HMBC correlations (Table 7), justifies the carbon skeleton of **59**. The protons at δ 7.11 and 7.02 are attributed to the H-2 and H-6 protons owing to the heterocorrelations with the C-7 carbon in a HMBC spectrum.

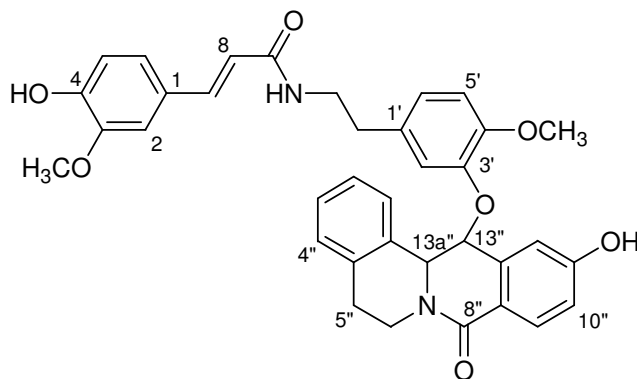

59

The protons at δ 6.75 and 7.06 are attributed to H-2' and H-6' on the basis of the heterocorrelations long-range with the C-1' and C-7'. The H-2' gives also cross peaks with the C-3' and C-4' and C-3' is also correlated to the H-5' and H-13'' at δ 6.72 and 5.89, respectively. The H-13'' is heterocorrelated to the C-8'', C-12'', C-1a'' and C-8a'' carbons of the alkaloid unit. The proton at δ 4.14, attributed to H-13a'', gives correlations with C-8'', C-6'' and C-13''. Finally the C-11'' and C-8a'' carbons give cross peaks with the H-12'' and H-9''. The coupling constant of 8.0 Hz between the H-13'' and H-13a'' protons is consistent with a dihedral angle of about 0° or 145° . The minimized structures corresponding to relative *cis* and *trans* configurations at H-13'' and H-13a'' protons, obtained by MM2 calculations (Allinger *et al.* 1980) generate dihedral angles of 45° and 175° respectively. These values correspond to 4.0 and 9.5 Hz couplings, respectively. Consequently, the measured value is compatible with a *trans* relative configuration. In accordance with this hypothesis, an analysis of the NOESY (fig. 7) spectrum evidences a NOE between 4'-OMe and H-13a''. The zero value of $[\alpha]_D^{25}$ indicates that the compound is a racemic mixture.

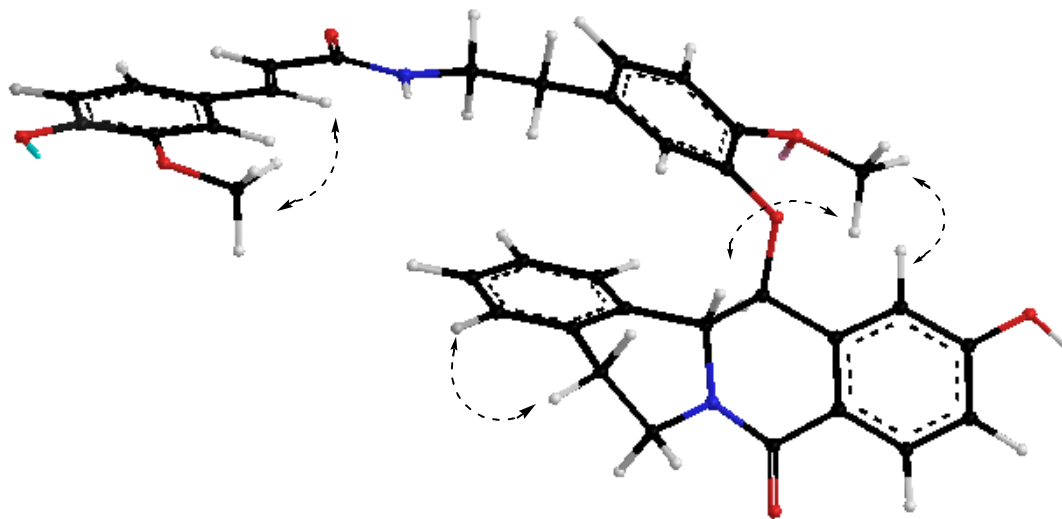

fig. 7. Selected NOEs of **59**.

Table 7. NMR Spectral Data of Compound **59** in CD₃OD

Position	$\delta_{\text{H}}^{\text{a}}$	NOESY	δ_{C}	HMBC (C) ^b
1			131.4 (q) ^c	
2	7.11 (<i>d</i> , 1.1)	MeO-3, 7, 8	113.4 (t)	3, 4, 7
3			151.4 (q)	
4			146.2 (q)	
5	6.74		116.8 (t)	
6	7.02 (<i>d</i> , 8.5)		130.6 (t)	1
7	7.43 (<i>d</i> , 15.5)	2, 6	141.8 (t)	2, 9
8	6.38 (<i>d</i> , 15.5)	2, 6	119.4 (t)	9
9			169.4 (q)	
1'			130.4 (q)	
2'	6.75		116.7 (t)	
3'			157.3 (q)	
4'			149.4 (q)	
5'	6.72		116.8 (t)	
6'	7.06 (<i>d</i> , 8.0)		130.6 (t)	
7'	2.76	2', 6'	36.0 (s)	
8'	3.45		42.4 (s)	
MeO-3	3.89 <i>s</i>	2	57.0 (p)	
MeO-4'	3.82 <i>s</i>	5', 12'', 13a''	56.5 (p)	
1''	6.76		116.7 (t)	
2''	6.79		120.3 (t)	
3''	6.75		118.3 (t)	
4''	7.02 (<i>d</i> , 8.5)	5''	130.6 (t)	
5''	2.75 <i>m</i>	4''	35.7 (s)	
6''	3.54 (<i>dd</i> , 13.2, 6.3); 3.45 (<i>dd</i> , 13.2, 6.8)		42.8 (s)	
8''			172.9 (q)	
9''	7.06 (<i>d</i> , 8.0)		130.7 (t)	
10''	6.74		116.7 (t)	
11''			148.2 (q)	
12''	6.91 (<i>d</i> , 1.2)		110.6 (q)	11'', 13'', 8a''
13''	5.89 (<i>d</i> , 8.0)	12''	90.0 (s)	8'', 1a'', 12'', 8a''
1a''			129.6 (q)	
4a''			131.2 (q)	
8a''			120.4 (q)	
12a''			132.9 (q)	
13a''	4.14 (<i>d</i> , 8.0)	1'', MeO-4'	59.0 (s)	8'', 13''

^a) ¹H chemical shift values (δ ppm from SiMe₄) followed by multiplicity and then the coupling constants (J in Hz). ^b) HMBC correlations from H to C. ^c) Letters, p, s, t and q, in parentheses indicate, respectively, the primary, secondary, tertiary and quaternary carbons, assigned by DEPT.

Compound **60** has been isolated for the first time. It shows an absorption maximum at 329 nm, suggesting the presence of a carotenal type chromophore (*Britton et al. 1995*). The molecular formula is determined as C₁₈H₂₆O₂ by EI MS. Of the two oxygen functions, one is ascribed to a secondary hydroxyl group (δ_{H} 4.26, δ_{C} 65.8) and the remaining one is attributed to a carbonyl group (δ_{C} 198.6), on the basis of ¹H NMR and ¹³C NMR data. The structure of **60** is established by using ¹H NMR and ¹³C NMR including COSY, ROESY, HMQC, and HMBC experiments. The ¹H¹H COSY experiment shows a correlation series beginning with the olefinic methine at δ 5.58, assigned to H-4, which is coupled with a carbinol methine at δ 4.26 (H-3) that is also coupled with two double doublets at δ 1.84 and 1.40 assigned to the H-2 methylene.

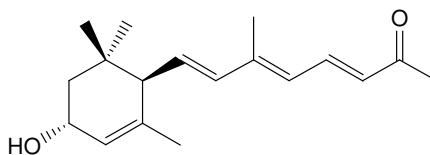

60

The proton signal at δ 6.20 assigned to H-8 is correlated with the H-7 proton (δ 5.69), which is coupled with the proton at δ 2.44 (H-6). The double doublet at δ 7.58, assigned to H-11 is correlated with H-12 and H-10 at δ 6.20 and 6.18 respectively. Five singlet methyls are also present in the ¹H NMR spectrum. ROESY correlations 15-CH₃/H-6, 16-CH₃/H-3 and H-7, 17-CH₃/H-4 and H-8 revealed the stereo structure of **60** as shown in figure 8. The CD spectrum showed a positive Cotton effect ($\Delta\epsilon_{330.0}$ +12.0), which establishes C-6 configuration as *R* (*Harada et al. 1983*). Therefore, the structure of **60** has been deduced to be (3*R*,6*R*,7*E*,9*E*,11*E*)-3-hydroxy-13-apo- α -caroten-13-one.

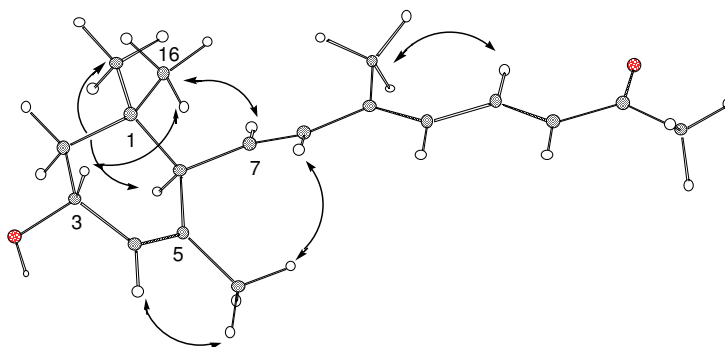
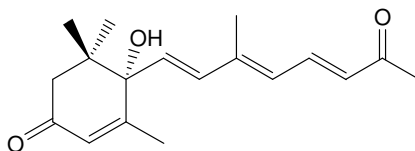

fig.8. Selected NOE interactions of compound **60**

Compound **61** shows an absorption maximum at 323 nm. The molecular formula has been determined as $C_{18}H_{24}O_3$ by EIMS. Of the three oxygen functions, one is ascribed to a tertiary hydroxyl group (δ_C 80.1) and the remaining two are attributed to carbonyl groups (δ_C 198.4). The partial structure of the 3-oxo- α -end group and the polyene chain in **61** are characterized by 1H NMR and ^{13}C NMR including COSY, ROESY, HMQC, and HMBC experiments. Present in the 1H NMR spectrum of **61** were five methyls as singlets, two aliphatic protons as douplets, and six olefinic protons as one singlet, four doublets and one double doublet. The $^1H^1H$ COSY experiment shows correlation of the olefinic methine at δ 5.96, assigned to H-7, and with H-8 at δ 6.47. The double doublet at δ 7.55, assigned to H-11 is correlated with H-10 and H-12 at δ 6.26 and 6.24 respectively. The ^{13}C NMR spectrum shows 16 carbon signals, identified, by a DEPT experiment, as five methyls, one methylene, eight olefinic carbons, two of them tetrasubstituted, two quaternary carbons and two carbonyls. All the carbons are correlated to the corresponding protons on the basis of an HMQC experiment. The tertiary hydroxyl group is positioned at C-6 on the basis of an HMBC experiment that shows correlations between C-6 and the H-7, H-8, H-15, H-16, and H-17 protons. The CD spectrum shows a positive Cotton effect, $\Delta\epsilon_{320.0}$ +43.0, suggesting C-6 has the *S* configuration (Harada 1983). Furthermore, ROESY correlations 15-CH₃/H-7, 16-

CH₃/H-2_{eq} and H-7, 17-CH₃/H-4 and H-8 confirm the stereo structure of **61**. Therefore, the structure of **61** is deduced to be (6*S*,7*E*,9*E*,11*E*)-3-oxo-13-apo- α -caroten-13-one, never reported previously.



61

Compound **62** has been identified as *S*-(+)-abscisic alcohol. The molecular formula assigned to compound **62** is C₁₅H₂₂O₃ and is derived from the molecular ion peak in a EI MS at *m/z* 250 [M]⁺ (80), which also shows the signal at *m/z* 235 ([M-Me]⁺). The ¹H NMR spectrum shows two large doublets at δ 6.34 and 7.74 (*J*=15.5 Hz) integrated for two protons, which are assigned to an olefinic systems. The singlet at δ 5.92 is also attributed to a trisubstituted double bond, and the proton H-10 resonates at δ 5.73. The large singlet integrated for two protons at δ 4.35 is indicative of a methylene functionalized by an hydroxyl. Finally the two large doublets at δ 2.27 and 2.45 (*J*=16.6 Hz) are the geminal protons of a cyclohexane. This structure is confirmed by comparison with previously reported spectroscopic data (Lunz *et al.*, 1992). Literature data also defines the configuration of the chiral centre, by considering the measured value of $[\alpha]_D^{25} +210$.

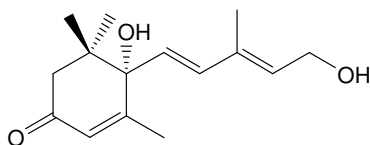

62

The spectral data of compounds **63-65** indicate the presence of an allenic group in these molecules. The ^1H NMR spectra present the olefinic proton at δ 5.84, 5.85 and 5.97, respectively, and in each ^{13}C NMR spectrum two sp^2 and one sp carbons are present. The data of compound **63** well match those of grosshopper ketone isolated from ant-repellant secretions of a large flightless grasshopper, *Romalea microptera* (Shiraga *et al.*, 1988). The isomeric **64** and **65** have been identified by comparison with previously reported spectroscopic data of the synthetic allenic zeaxanthin end group (Hlubucek *et al.*, 1974 and Baumeler *et al.*, 1990). Absolute stereochemistry for each compound is assigned through the measured $[\alpha]_{\text{D}}^{25}$ values, by comparison with literature data.

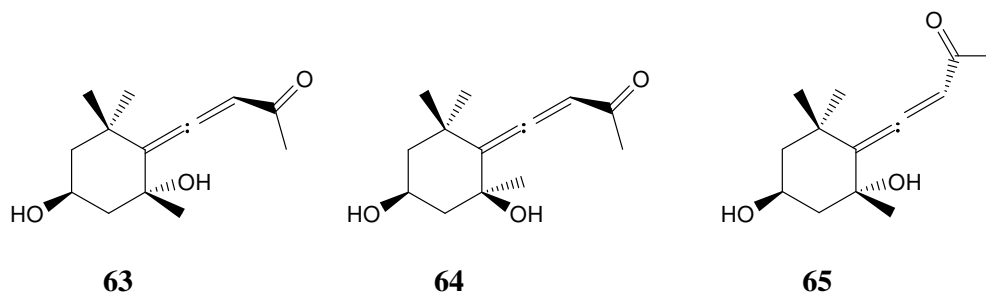

Compound **66** has been identified as (3*R*,6*R*,7*E*)-3-hydroxy-4,7-megastigmadien-9-one. The ^1H NMR spectrum shows the signals of three protons on unsaturated systems, two of them disposed in the *trans* geometry of a double bond ($J=15.5$ Hz). The multiplet at δ 4.27 is of an alcoholic methine, which correlates in a $^1\text{H}^1\text{H}$ COSY experiment to two protons geminally coupled on a cyclohexane ring and to an olefinic proton. The spectrum also presents the signals of four singlets attributed to four methyls. The CD spectrum shows a positive Cotton effect ($\Delta\epsilon_{293\text{nm}} = +24$), establishing the C-6 configuration as *R*. The $[\alpha]_{\text{D}}^{25}$ measurement compared to literature values, defines the *R* configuration at C-3 (D'Abrosca *et al.*, 2004).

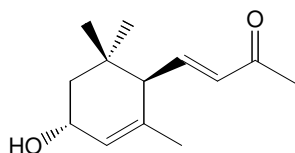

66

Structurally related to the last compound but having a lower oxidation state is compound **67**, identified as (3*R*,6*R*,7*E*,9*R*)-3,9-dihydroxy-4,7-megastigmadiene. Its structural characterisation has been realized through the ^1H NMR data, which perfectly match previously reported results (*D'Abrosca et al.*, 2004). The two double doublets at δ 5.59 and 5.38 are assigned to the protons of the olefine system, H-8 and H-7, respectively.

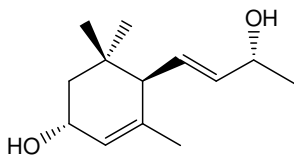

67

The first is correlated in a $^1\text{H}^1\text{H}$ COSY experiment to H-9 (δ_{H} 4.33), whose complex multiplicity is due to the coupling with the adjacent methyl protons H-10 (δ_{H} 1.28). The remaining broad singlet due to an olefinic proton at δ 5.52 is attributed to H-4, which is coupled to H-3 at δ 4.21. The double doublet at δ 1.82 ($J=13.5$ and 5.8 Hz) is due to the H-2 proton in pseudo-axial position, while H-2eq. resonates as a doublet at δ 1.36 ($J=13.5$ and 6.3 Hz). The four methyls give resonances at δ 1.28, 1.61, 0.99 and 0.84. A NOESY experiment confirms the relative configuration from the cross peaks between H-3 and H-7, H-8 (figure 9). The absolute configuration is defined by comparison of the measured $[\alpha]_{\text{D}}^{25}$ with literature values.

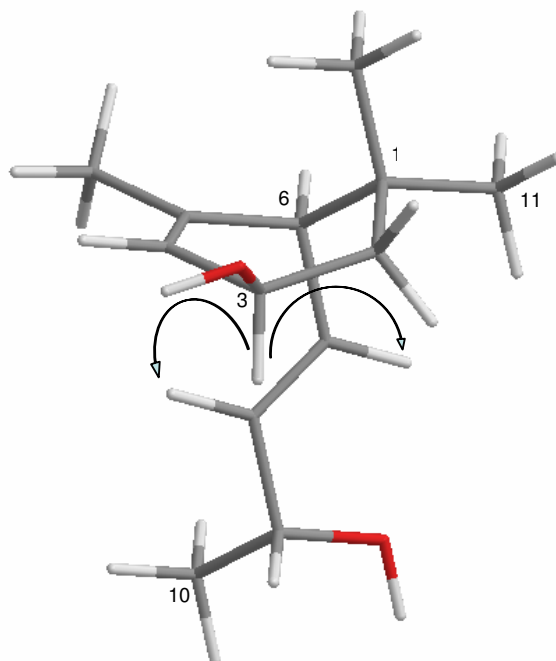
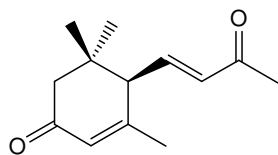

fig. 9- Selected NOE of compound **67**.

The oxidation of the hydroxy-functions in 3 and 9 of compound **67** gives compound **68** that has been identified as (6*R*,7*E*)-4,7-megastigmadien-3,9-dione. The double doublet at δ 6.68 is due to the olefinic proton H-7, while H-8 resonates as a doublet at δ 6.17. The singlet at δ 5.99 is attributed to the proton H-4, while H-2 protons resonate at δ 2.70 and 2.18 as doublets. Comparison with literature data (*Behr et al. 1985*) confirms the characterisation described and defines the absolute stereochemistry.



68

Compound **69** is defined as (6*R*,9*R*)-9-hydroxy-4-megastigmen-3-one through its spectral data. The ^{13}C NMR spectrum defines the presence of an α,β -unsaturated system (δ_{C} 199.6/C-3, 125.1/C-4, 165.8/C-5) and of a carbinol carbon (δ_{C} 68.0), four methyls (δ_{C} 24.6, 28.8, 27.2 and 23.7), three methylenes (δ_{C} 26.2, 38.6, 47.1) and a methine (δ_{C} 51.1).

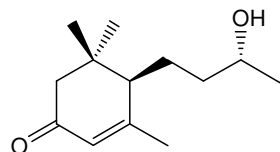

69

In the ^1H NMR spectrum two methylene protons resonate as two large doublets at δ_{H} 2.39 and 2.04, while the two remaining methylenes resonate in the range δ_{H} 1.00-1.90. An olefinic proton resonates as a singlet at δ_{H} 5.84. The four methyl resonances are at 1.99 (H-13), 1.21 (H-10), 1.07 (H-11) and 1.02 (H-12). Previously reported data confirm the described structure (*D'Abrosca et al. 2004*).

Compound **70** has been identified as 3,9-dihydroxy-4-megastigmen-3-one. The ^{13}C NMR shows the presence of an olefinic system that a DEPT experiment settles as consisting of a quaternary carbon and a methine.

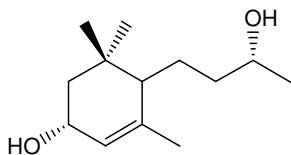

70

The methine proton resonates at δ 5.38 and it is correlated by an $^1\text{H}^1\text{H}$ COSY experiment to a proton at δ 4.28, assigned to H-3. The latter is also coupled to H-2 protons at δ 1.82 and 1.36. The $^1\text{H}^1\text{H}$ COSY experiment also defines the presence of a C-4 side chain. Comparison with literature data confirms the assigned structure (*Prestwich et al., 1976*).

Spectral data of compound **71** identify it as 4-megastigmen-3,9-dione. The ^{13}C NMR spectrum shows the signals of two carbonyl carbons at δ 207.0 and 199.1. The latter is conjugated to a double bond, whose carbons resonate at δ 125.6 and 164.8. Three methylenes are also present, two of them are mutually coupled in a C-2 alkanic chain as it is shown in a $^1\text{H}^1\text{H}$ COSY experiment. This experiment also highlights the correlation of the H-7 protons to H-6, which resonates at δ 1.74. An HMBC experiment confirms the assigned carbon skeleton (*Aasen et al. 1974* and *D'Arcj 1997*).

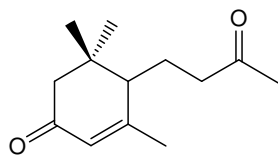

71

Compound **72** has been identified as 3,6,9-trihydroxy-4-megastigmenone. The ^{13}C NMR spectrum shows the signals of two olefinic carbons and three carbinols. Three methylenes and four methyls are also present. In the ^1H NMR spectrum the two signals at δ 4.10 and 3.65 are attributed to H-3 and H-9, respectively. The proton H-3 is coupled in a $^1\text{H}^1\text{H}$ COSY experiment to the olefinic proton at δ 5.35 and the two H-2 protons at δ 1.40 and 1.53. Proton H-9, instead, correlates to H-8 protons distributed in the chemical shift range δ 1.20-1.25, and H-10 (δ_{H} 1.15). The H-8 protons are also

correlated to the protons resonating in the chemical shift range δ 1.47-1.53, attributed to H-7. C-3 and C-6 resonances define hydroxyl positions. Literature data agrees perfectly with the assigned structure (Straus *et al.*, 1986).

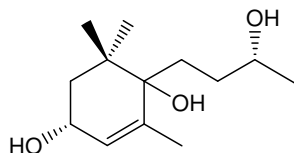

72

Compound **73** has been identified as (6Z,9S)-9-hydroxy-4,6-megastigmadien-3-one, previously obtained by reduction of dehydroionone (D'Abrosca *et al.*, 2004). The four olefinic carbons resonate at δ 129.0, 144.6, 155.9 and 126.6 (C4, C-5, C-6, C-7 respectively), while corresponding protons, correlated through an HSQC experiment, resonate at δ 5.92 (H-4), and 5.74 (H-7). Proton H-7 appears in a ^1H NMR spectrum as a triplet, because of its coupling to the adjacent H-8 protons, as it is shown by the $^1\text{H}^1\text{H}$ COSY experiment. The same experiment shows H-8 protons correlated to the carbinol proton H-9, which also gives cross-peaks with H-10 (δ 1.25, d, $J=6.0$ Hz). The singlet integrated for two protons at δ 2.30 is due to H-2 protons. Methyls resonate at δ 2.23 (H-13), 1.25 (H-10), 1.18 (H-11 and H-12).

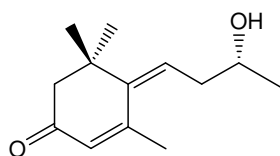

73

Nor-terpenes **14**, **16**, **33** and **34**, already isolated from *Brassica fruticulosa* and *Malva silvestris*, have also been found in *Chenopodium album* extracts.

BIOASSAYS

The chemical analysis of the three Mediterranean plants has led to the isolation of secondary metabolites having different structures and biogenetic origins. In particular there have been isolated: seven lignans (**1-5**, **47**, **48**), four neolignans (**6-10**), five sesquilignans (**12**, **13**, **49-51**), one dilignan (**11**), eight C-13 *nor*-terpenes (**14-18**, **33-35**), three degraded carotenoids (**60-62**), two monoterpenes (**30**, **31**), one sesquiterpenes (**32**), one diterpenes (**36**), nineteen phenol derivatives (**19-29**, **37-44**), one triptamine (**46**), one benzaldehyd derivative (**45**), three allenes (**64-66**) and eight cinnamic amides (**52-59**).

Some of the isolated compounds have been tested on seeds of standard plants to evaluate their biological activity. The assays have been run in accordance with the procedures optimised by *Macias et al. (2000)*. The results are reported by grouping the molecules for structure similarities and common biogenetic origins.

Lignans, neolignans, sesquilignans and dilignans biogenetically derive from the oxidative coupling of phenylpropanoic units through radicalic processes. The phenylpropanoic units are in turn biosynthesized along the shikimic acid pathway.

Cinnamic amides are constituted by a unit of cinnamic acid bonded through an amidic link to a dopamminic unit. The two aromatic groups constituting the molecules are both derived from the shikimic acid pathway. The phenolic, triptamminic and benzaldehydic derivatives originated from the same metabolic path. *Nor*-terpenes, monoterpenes, sesquiterpenes, diterpenes, carotenoids and allenes are all terpenoids originating from the mevalonic acid pathway.

Obtained data are shown as percentage differences of germination, root elongation and shoot elongation from the control.

Phytotoxic activity of lignans, neolignans, sesquilignans and dilignans.

Compounds **1-13**, except compound **9**, isolated from *B. fruticulosa* have been tested on two dicotyledons, *Lactuca sativa* L (lettuce) and *Lycopersicon esculentum* M. (tomato), and on the monocotyledon *Allium cepa* L. (onion), to evaluate the inhibitory or stimulatory effects on germination and seedling growth. The results are reported as percentage differences of germination (**figure 10**), root elongation (**figure 11**) and shoot elongation (**figure 12**) from the control. The most relevant effect observed is a strong inhibition of germination of *L. sativa* produced by compounds **2-4**, **6**, **7**, **11** and **13** (**figure 10A**). Lignan **4** is the most active and retains 75% inhibition at the lower concentration (10^{-9} M). Also the lignans **2** and **3** are toxic and showed 50% inhibition at 10^{-9} M. Among the neolignans, compounds **6** and **7** have inhibitory effects: dehydroconiferyl alcohol (**6**) shows about the 70% inhibition at all the tested concentrations. The dilignan **11** and the sesquilignans **12** and **13** are also active on the lettuce germination. The effects on the germination of *L. esculentum* and *A. cepa* are not particularly notable (**figure 10B** and **10C**). The root length of the dicotyledon species shows similar trends but the effects are weak. All the compounds have a light stimulatory effect on the onions, with the exception of the lignan **2** (**figure 11**). The shoot elongation of the three test species have a variable behaviour within the 25-30% of the stimulatory or inhibitory effect (**figure 12**). In conclusion, compounds **2-4**, **6**, **11** and **13** are the most active products for inhibiting lettuce germination and their inhibiting activity is retained also at 1 nM concentration. The high values of inhibiting activity due to compounds **2**, **4** and **6**, suggests their potential use as natural herbicides. Therefore, these three natural compounds have been compared with two commercial herbicides widely used in agriculture, Pendimethalin and Glyphosate. The first is a pre-

emergence pesticide, while the second is a broad spectrum, post-emergence herbicide. The results, reported in **figure 13** show greater phytotoxic activity on lettuce germination of compounds **4** and **6** in respect to the pesticides. Both the lignans reveal over 70% inhibition also at 1 nM concentration (**figure 13A**). Compound **2** is less active than Pendimethalin but more toxic than Glyphosate, especially at the lower concentrations (10^{-8} and 10^{-9} M). The root length is slightly affected by the natural tested compounds in respect to the pesticides, as reported in **figure 13B**. The shoot length is stimulated by lignans, and they show effects comparable to those of Pendimethalin (**figure 13C**). Literature data reported that this herbicide acts as an inhibitor for cell division and elongation (*Hess et al. 1997 and Richard et al. 1999*). Furthermore, studies on the alga *Protosiphon botryoides* indicated that growth rate, cell number, chlorophyll level and dry weight decrease with increasing Pendimethalin concentration (*Shabana et al. 2001*). The variety of biological activities displayed by lignans is remarkable and antitumor, antimitotic antiviral and other activities are widely reported in the literature (*Macrae et al. 1993*). Not much evidence is reported for their germination inhibitory activity. *Szabo and Garay (1970)* reported that the lariciresinol-*O*-glucoside and some monoepoxylygnans (*Lavie et al. 1974 and Yoshihara et al. 1982*) show germination inhibition. Recently, *Rimando et al. (1999)*, have reported the isolation of phytotoxic furofuran lignans from *Leucophyllum frutescens*. The results indicated that diastereoisomeric compounds have different inhibitory activities on *L. sativa* and *A. cepa*. Furthermore, *Oliva et al. (2002)* have reported the phytotoxic activity of some aryltetralin lignans from plants of the genus *Podophyllum* on lettuce, onion, and rye. The results of the phytotoxic activity of the lignans from *B. fruticulosa* confirm their potential phytotoxic role and the relative natural abundances of these metabolites suggest their potential use as selective natural pesticides.

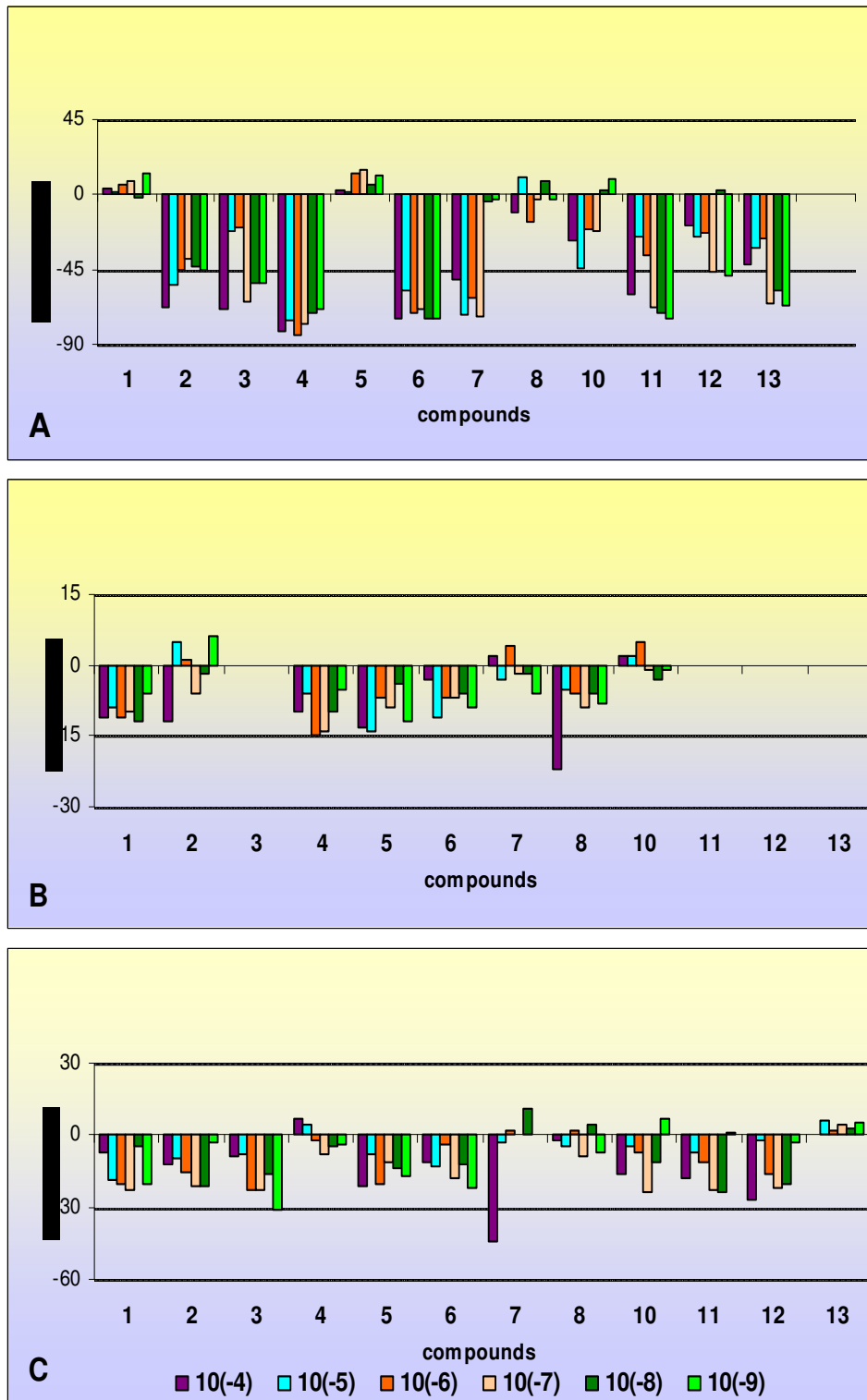

figure 10. Effect of compounds **1-8, 10-13** on germination of *Lactuca sativa* L. (A), *Lycopersicon esculentum* (B), and *Allium cepa* (C). Values presented as percentage differences from control.

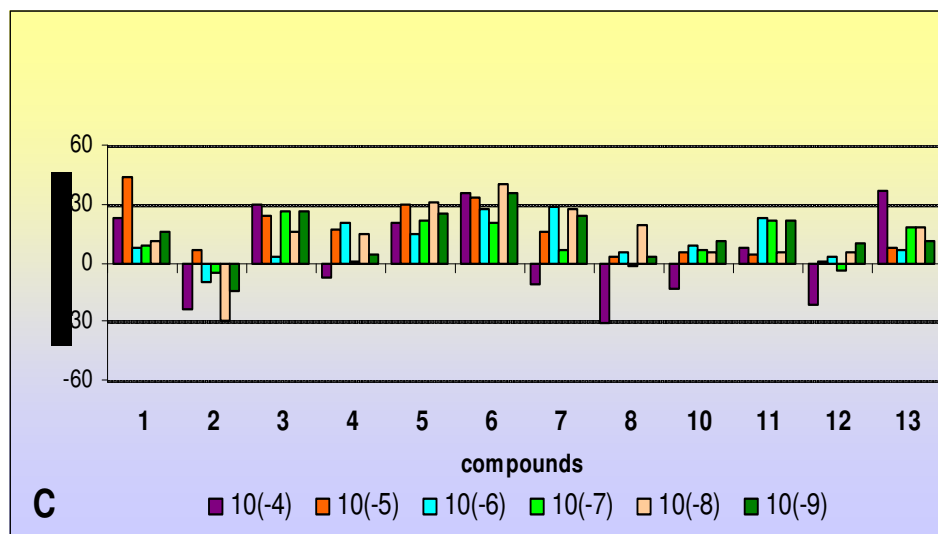
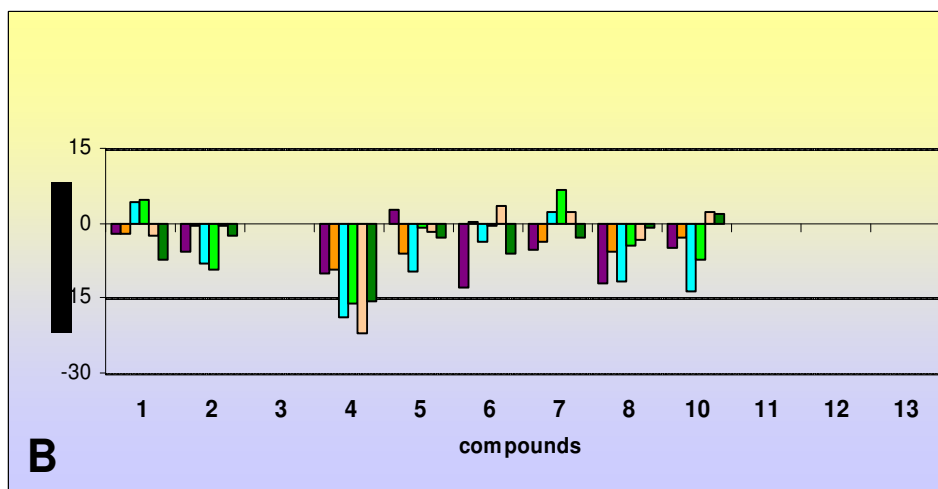
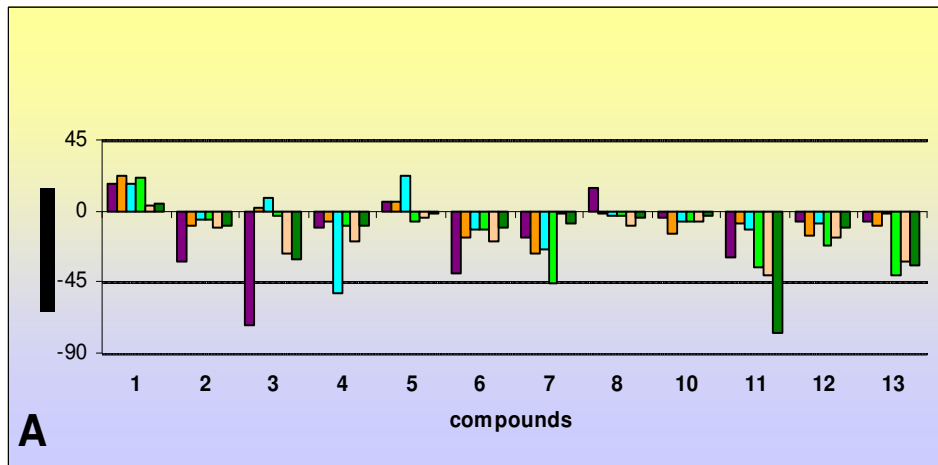

figure 11. Effect of compounds **1-8, 10-13** on root length of *Lactuca sativa* L. (A), *Lycopersicon esculentum* (B), and *Allium cepa* (C). Values presented as percentage differences from control.

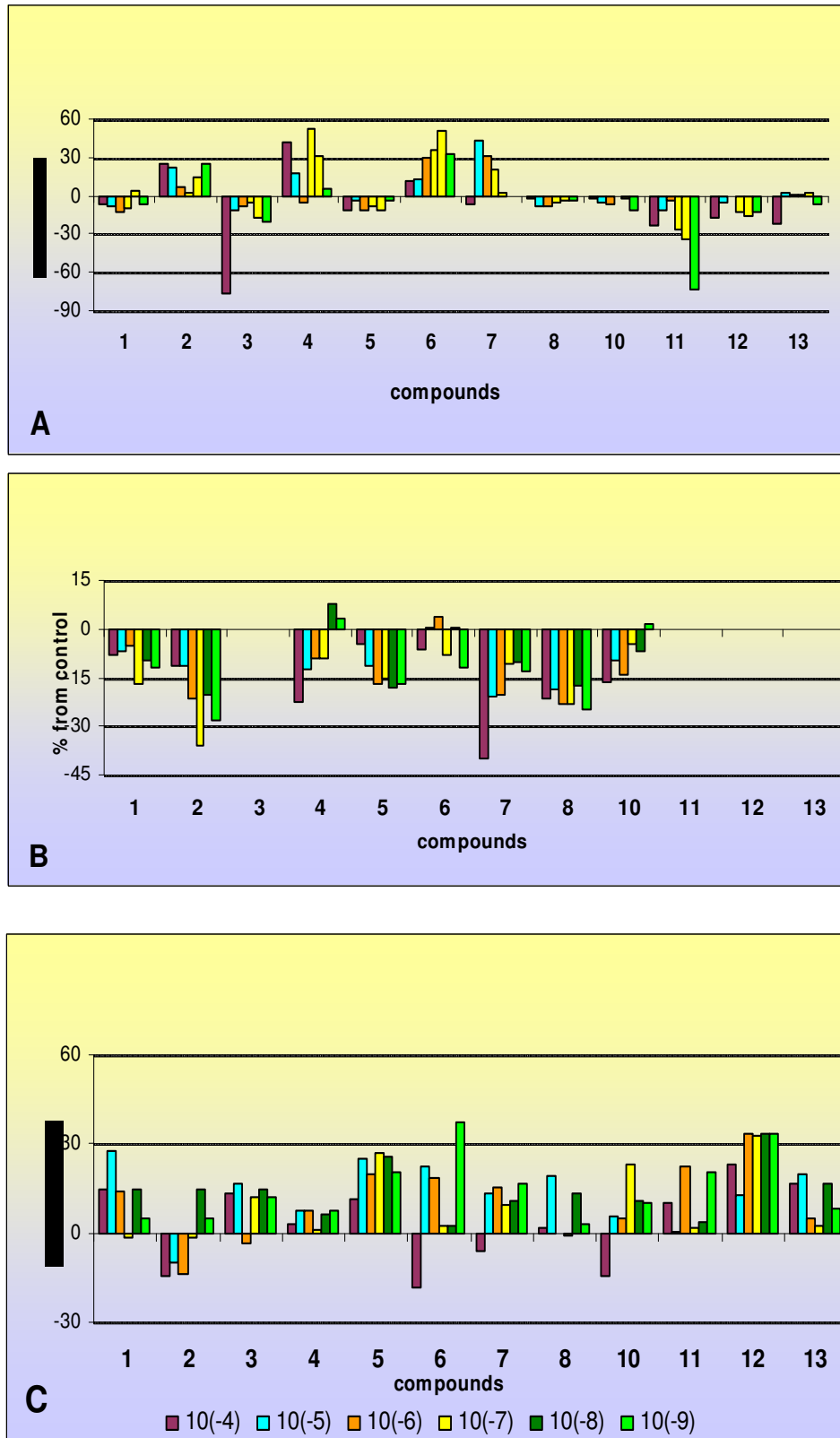

figure 12. Effect of compounds 1-8, 10-13 on shoot length of *Lactuca sativa* L. (A), *Lycopersicon esculentum* (B), and *Allium cepa* (C). Values presented as percentage differences from control.

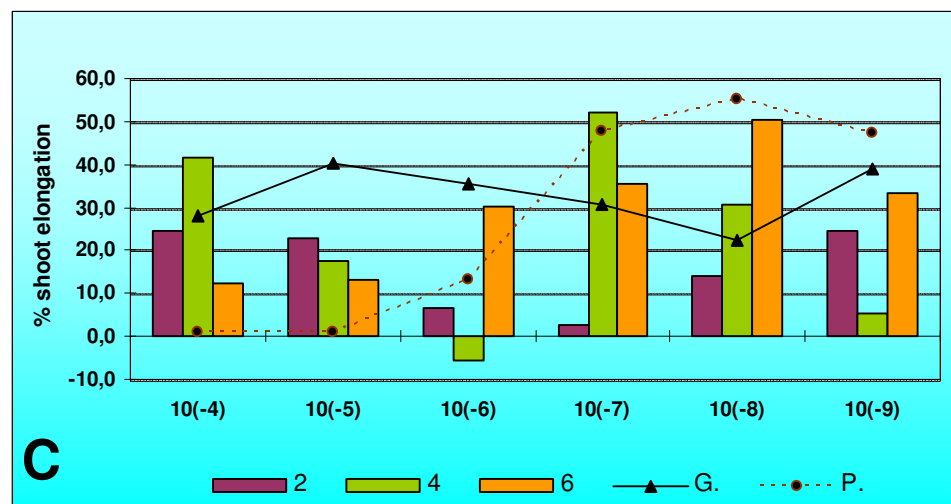
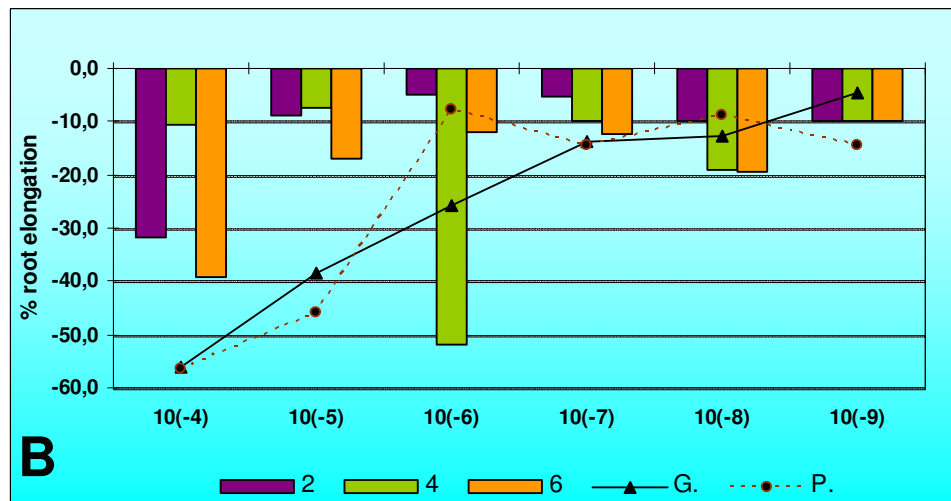
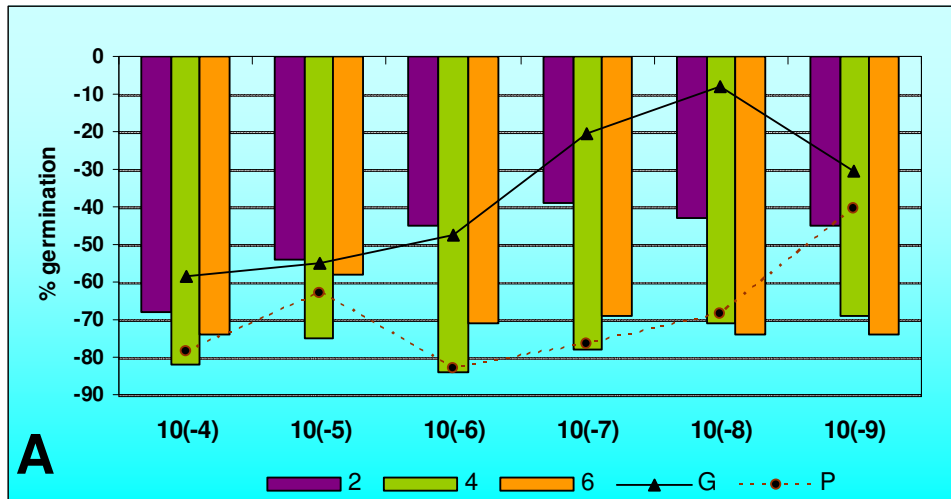

figure 13. Effect of compounds 2, 4, 6 on germination of *Lactuca sativa* L. (A), *Lycopersicon esculentum* (B), and *Allium cepa* (C), compared to commercial herbicides Pendimethalin (P) and Glyfosate (G). Values presented as percentage differences from control.

Phytotoxic activity of nor-terpenes, monoterpenes, sesquiterpenes, diterpenes, carotenoids and allenes

Some of the isolated terpenoids have been tested for their phytotoxicity on the seed of *Lactuca sativa*. Aqueous solution of **14**, **16**, **17**, **30-33**, **35**, **60-71**, **73**, ranging between 10^{-4} and 10^{-7} M, have been tested on germination, root length and shoot length of treated lettuce seeds.

Compounds **69** and **70**, differing only for the oxidation state of C-3, show small effects on seed germination (**figure 14A**), which is at most 6%. Effects on root elongation are almost absent for compound **70** (12%) and completely absent for **69** (**figure 14B**). Both compounds inhibit shoot elongation by 10% (**figure 14C**). Slightly more significant are the effects of **71**, **73** whose inhibiting activity on germination is 16% and 12% at 10^{-4} M, respectively. Root and shoot elongation are inhibited 25% by compound **71**.

The new apocarotenoids (**60-61**) reduce the germination by 20% at 10^{-4} M (**figure 15A**). The structurally similar compound **62** almost completely inhibits (90%) lettuce germination at 10^{-4} M (**figure 15A**), and reaches 100% inhibitory effect on root and shoot elongation at this concentration (**figure 15B** and **C**). Among compounds **63-65**, only the allene **65** reduces the shoot length (30%) and root length (20%) at 10^{-7} M (**figure 15C** and **B**), while they do not affect seed germination.

Compounds **14** and **67** differing for the oxidation state of C-3 have almost no effects on seed germination (at most 6% at 10^{-6} M for **67**) (**figure 16A**), and a bare effect on root and shoot length (**figure 16B** and **C**). Compounds **16** and **33** are slightly more active, inhibiting germination by 16% and 10% respectively, at 10^{-3} M (**figure 16A**). Bioactivity of compounds **66** and **68** is more intense. They inhibit germination by 30% (at 10^{-7} M) and 33% (at 10^{-4} M), respectively (**figure 16A**).

Compounds **17**, **31** and **35** do not show any significant activity on either germination or seed growth (**figure 17**). Compound **32** instead has a satisfactory action on germination (45% at 10^{-6} M) (**figure 17A**), while it shows almost no action on root and shoot growth (**figure 17 B** and **C**). Compound **30** is the most bioactive, inhibiting germination by 90% at 10^{-4} M (**figure 17A**).

Bioactivity of the isolated terpenoids shows a variable response on the tested specie and for some compounds no dose dependence effects are observed. The reason for this response may be due to differences in seed size, seed coat permeability, differential uptake and metabolism (*Macias et al. 1997*).

Inhibitory power showed by bioactive compounds is comparable to that of 4-hydroxybenzoic acid, which is known to be an effective germinator inhibitor (*Cuttillo et al. 2003*).

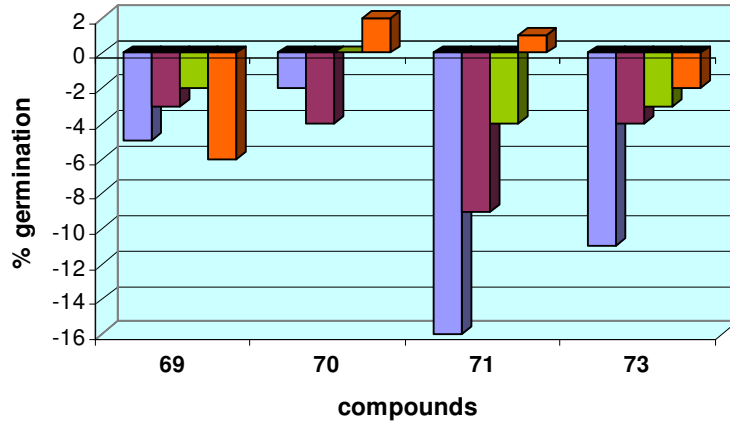

A

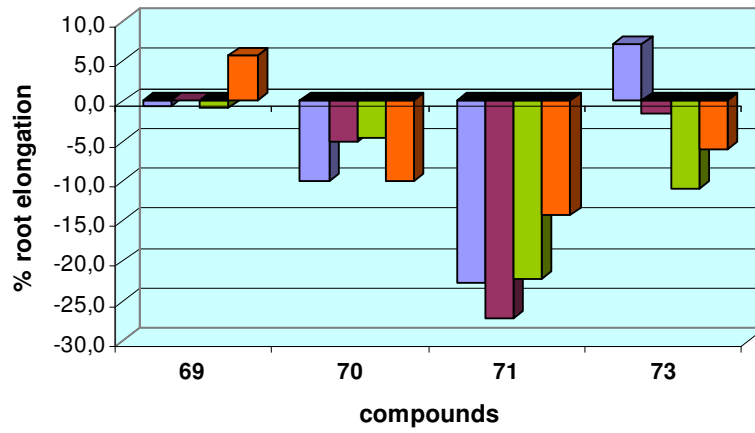

B

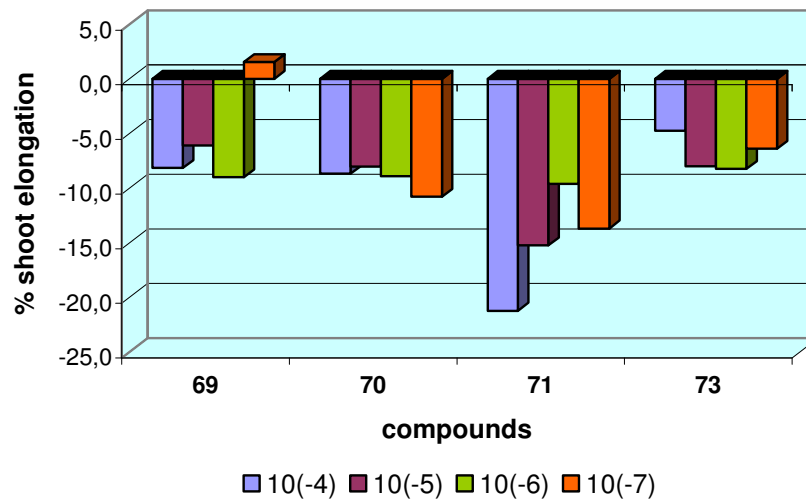

C

■ 10(-4) ■ 10(-5) ■ 10(-6) ■ 10(-7)

figure 14- Effects on *Lactuca sativa* germination, root elongation and shoot elongation of compounds 69-73.

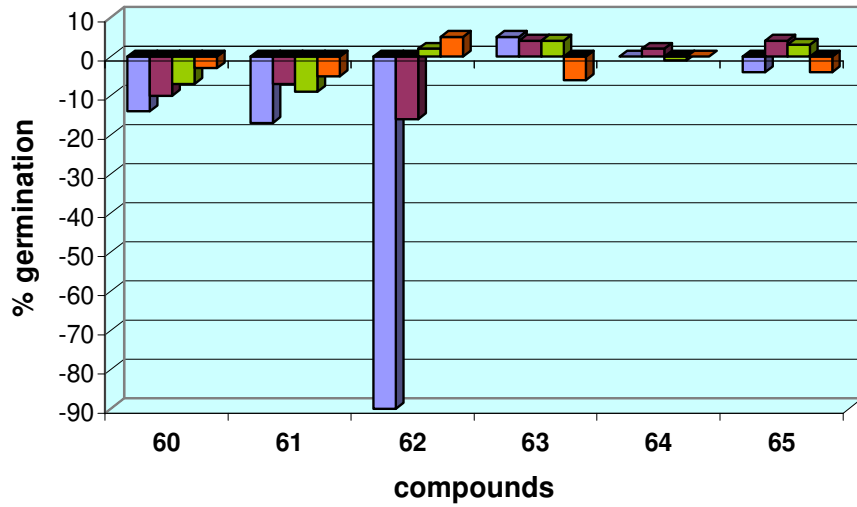

A

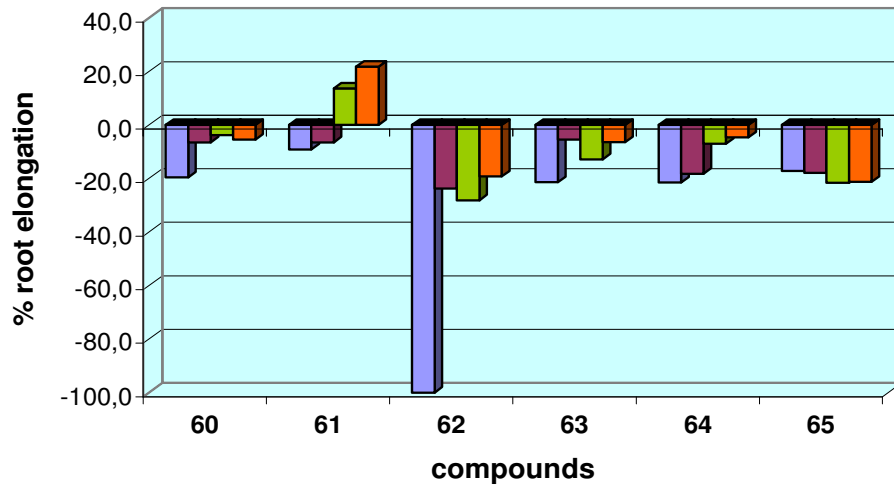

B

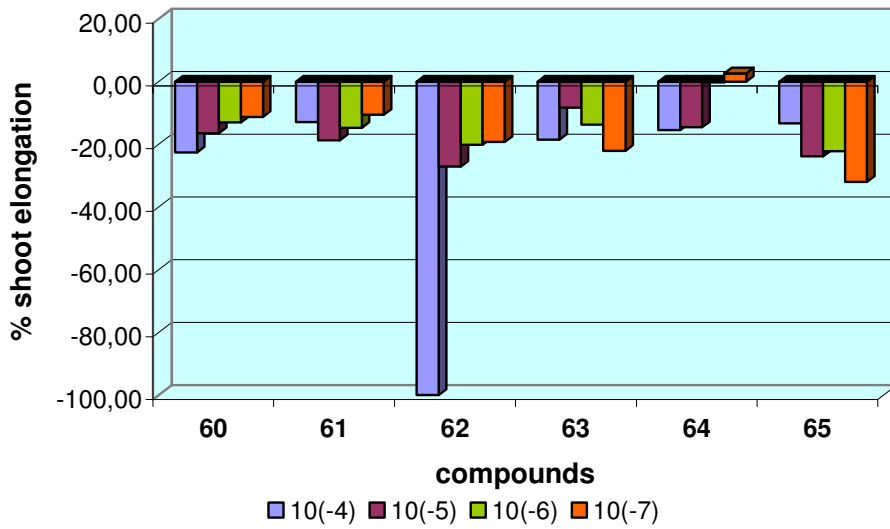

C

figure 15- Effects on *Lactuca sativa* germination, root elongation and shoot elongation of compounds 60-65.

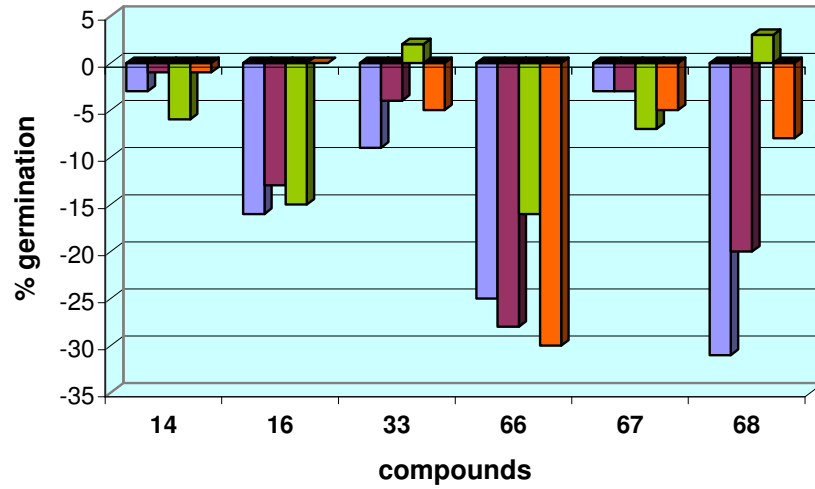

A

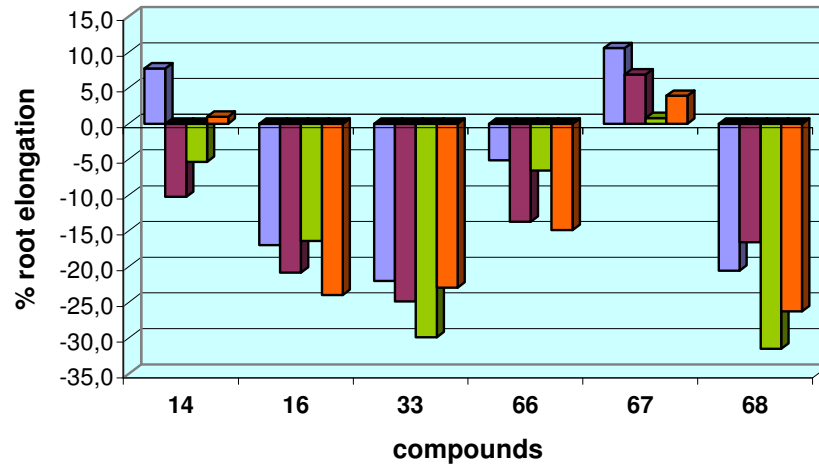

B

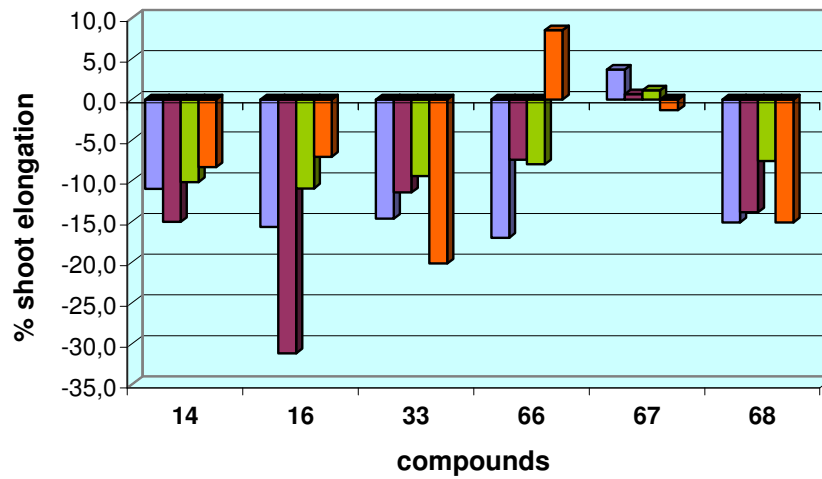

C

■ 10(-4) ■ 10(-5) ■ 10(-6) ■ 10(-7) ■ 10(-8)

figure 16- Effects on *Lactuca sativa* germination, root elongation and shoot elongation of compounds 14, 16, 33, 66-68.

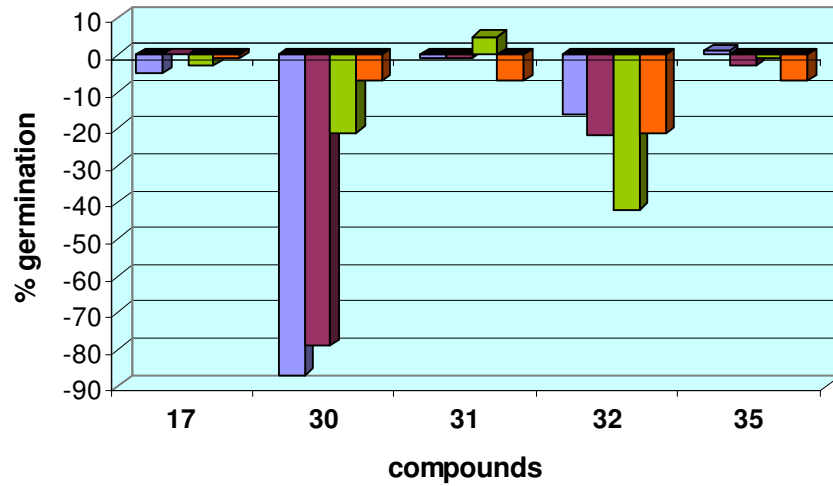

A

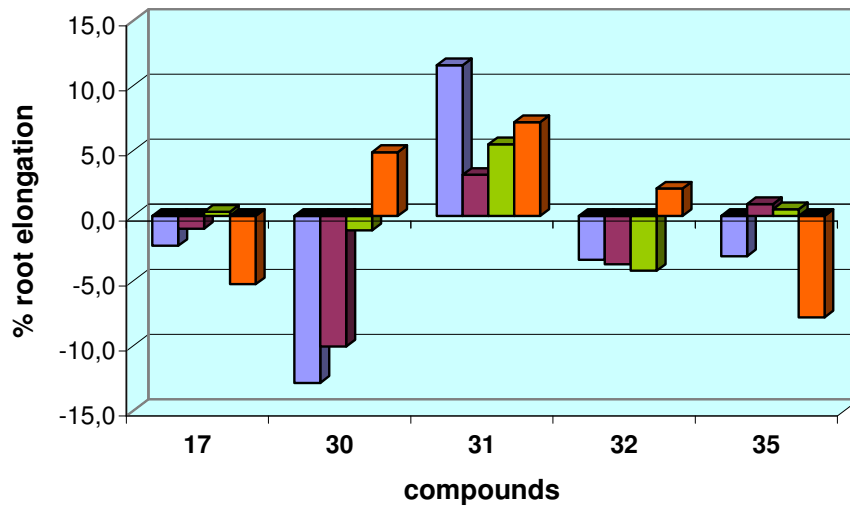

B

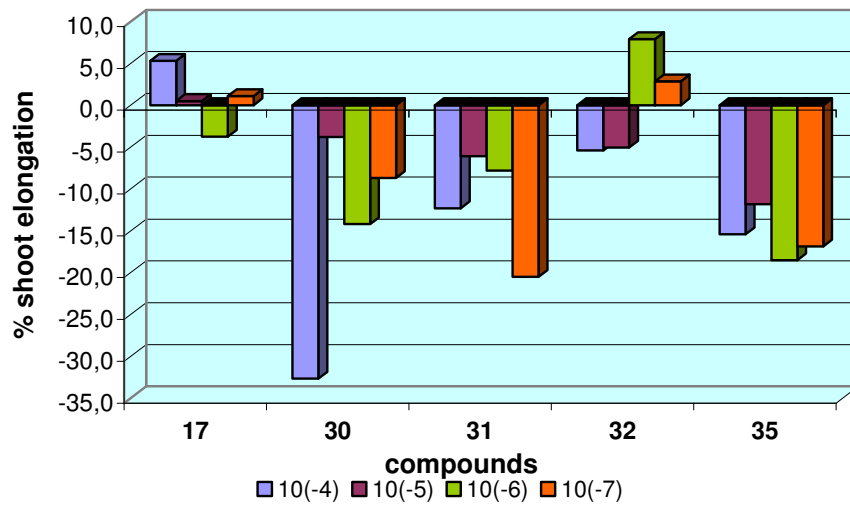

C

figure 17- Effects on *Lactuca sativa* germination, root elongation and shoot elongation of compounds 17, 30-32, 35.

Phytotoxic activity of cinnamic amides and Chenoalbicin

The seven amides **52-58** have been tested on lettuce, tomato and onion to evaluate the effects on germination and seedling growth. Compounds **53, 55-58** cause about 15% inhibition on the germination of lettuce in the tested concentration range and no dose dependence effects have been observed (**figure 18A**).

Compound **52** is not active, while compound **54** causes 45% inhibition at the highest concentration tested. Comparable effects have also been found on tomato (**figure 18B**). The responses on onion germination are different: compounds **53, 56** show inhibitory effects, compounds **57, 58** are inactive and compounds **52, 54** stimulate the germination (**figure 18C**).

The effects of amides on the root length of dicotyledons are quite small (**figures 19A and 19B**). At 10^{-4} M concentration about 15% inhibition is observed on lettuce, while on tomato only compounds **54, 55** and **57** cause the same inhibition. On the contrary the root length of onion is stimulated by amides, with exception of **56** which causes 50% reduction at 10^{-5} M (**figure 19C**).

The compounds stimulate the shoot length of lettuce, while tomato response is the opposite with exception of compound **55** (**figures 20A and 20B**). Onion shoot length is inhibited by the compounds at all concentrations tested (**figure 20C**). Bioactivity of cinnamic acid amides varies with the tested species and for some compounds no dose dependence effects has been observed.

Also for compounds **52-58** a bioactivity comparison was conducted with 4-hydroxybenzoic acid, which is recognized to be an effective herbicide (*Sebeson et al. 1969 and Mizutani 1999*). Data are reported in **figure 18**.

The inhibition value at 10^{-4} M on lettuce for 4-hydroxybenzoic acid is comparable to that of amides **53**, **57** and **58** but lower for **54**. The effects on tomato at the highest concentration tested are about the same as for compounds **57** and **58**, while amide **54** results six-fold more toxic than the control. Anti-germination effects on onion are higher for 4-hydroxybenzoic acid than for amides.

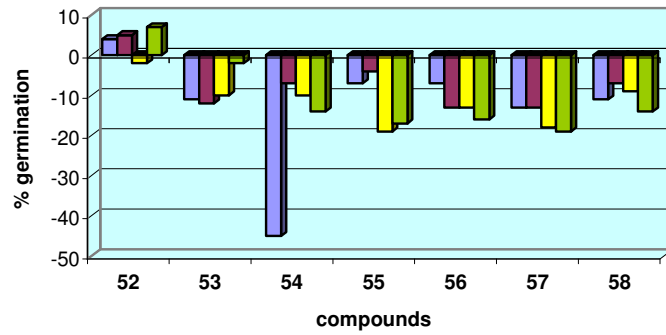

A ■ 10(-4) M ■ 10(-5) M ■ 10(-6) M ■ 10(-7) M

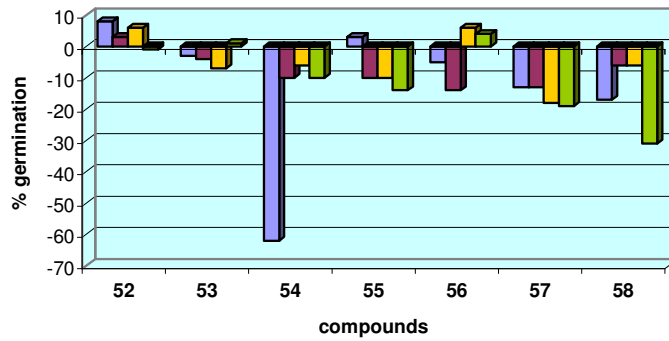

B ■ 10(-4) M ■ 10(-5) M ■ 10(-6) M ■ 10(-7) M

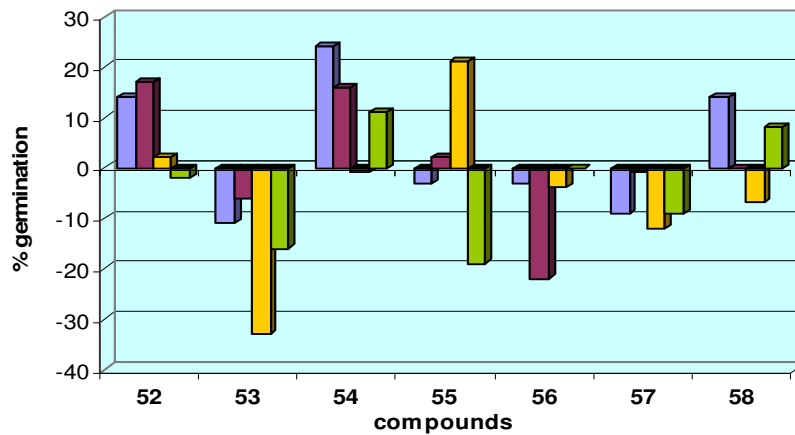

C ■ 10(-4) M ■ 10(-5) M ■ 10(-6) M ■ 10(-7) M

figure 18- Effect of compounds 52-58 and pHBA (4-hydroxybenzoic acid) on germination of *Lactuca sativa L.* (A), *Lycopersicon esculentum* (B), and *Allium cepa* (C). Value presented as percentage differences from control.

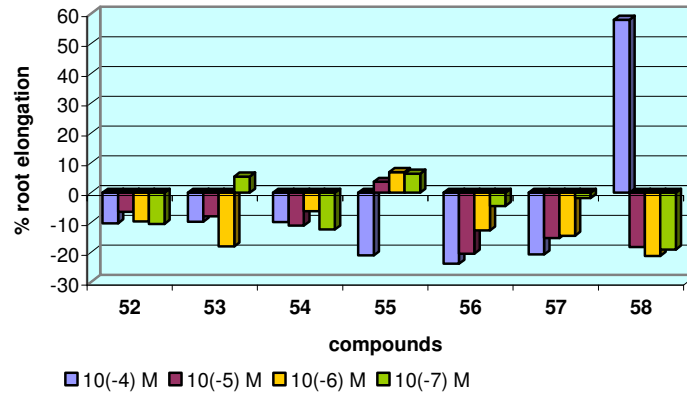

A

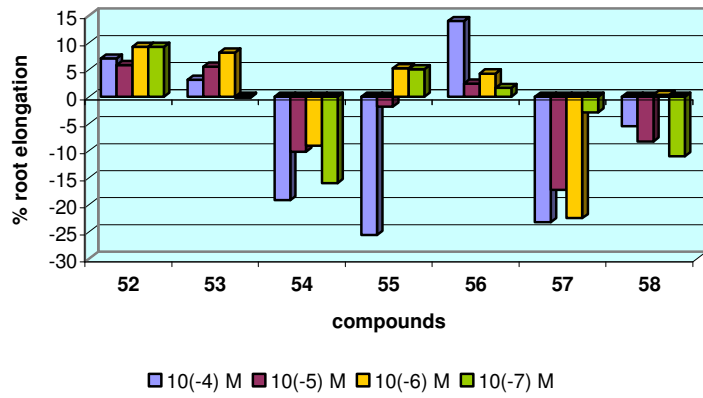

B

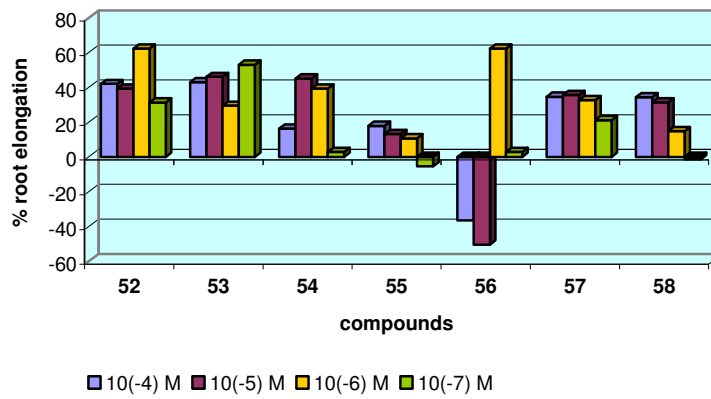

C

figure 19 - Effect of compounds **52-58** on root length of *Lactuca sativa* L. (A), *Lycopersicon esculentum* (B), and *Allium cepa* (C). Values presented as percentage differences from control.

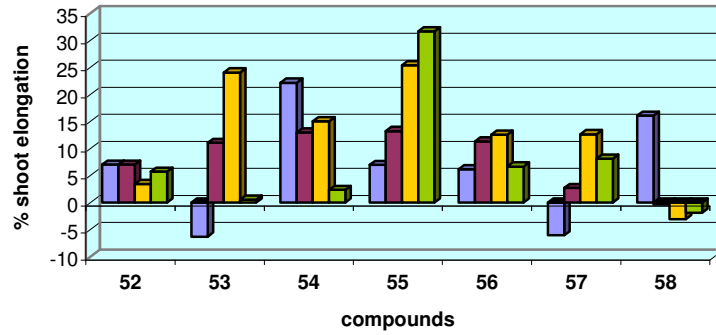

A 10(-4) M 10(-5) M 10(-6) M 10(-7) M

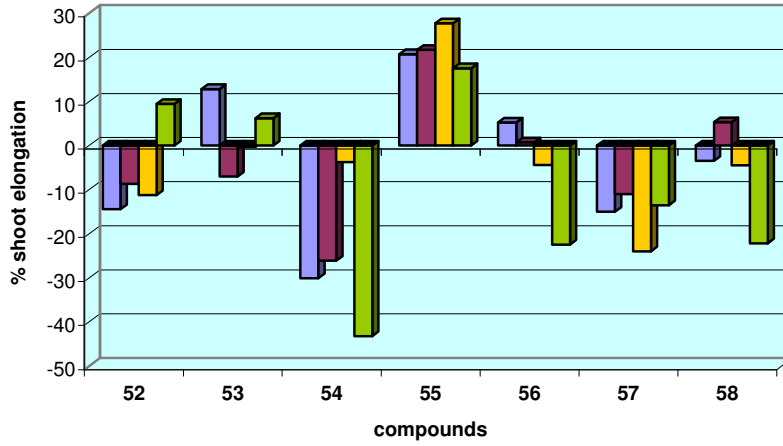

B 10(-4) M 10(-5) M 10(-6) M 10(-7) M

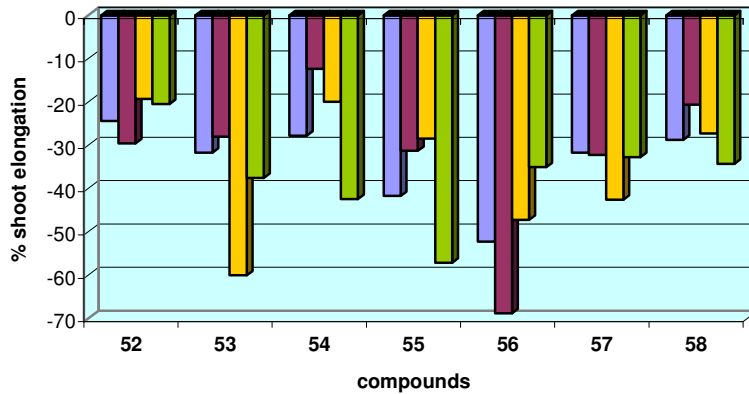

C 10(-4) M 10(-5) M 10(-6) M 10(-7) M

figure 20 - Effect of compounds **52-58** on shoot length of *Lactuca sativa L.* (A), *Lycopersicon esculentum* (B), and *Allium cepa* (C). Value presented as percentage differences from control .

Compound **59** has been tested on *Lactuca sativa* L. (lettuce). **Figure 21** reports the results on germination, root elongation and shoot elongation in a concentration range from 10^{-4} to 10^{-7} M. Chenoalbicin shows a low inhibitory effect, about 15 %, on the seedling growth, while it is almost inactive on seed germination. The correspondent molecule without the alkaloid moiety (compound **53**) is scarcely active as well (**figure 20**).

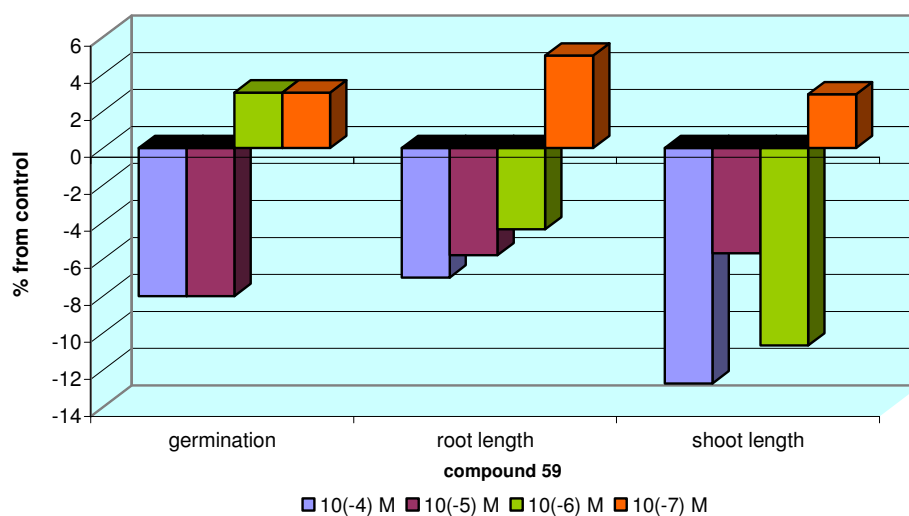
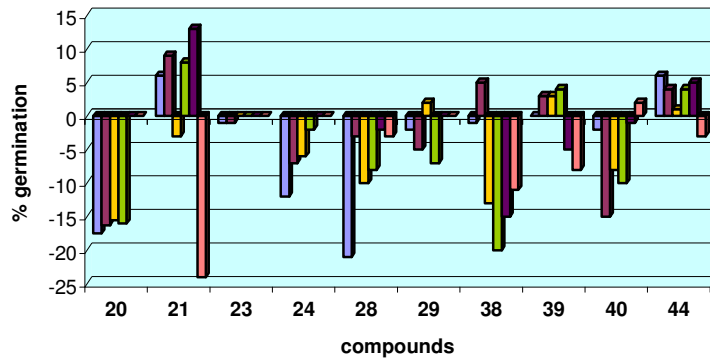

figure 21 - Effect of compounds **59** on germination, root length and shoot length of *Lactuca sativa* L. (A). Values presented as percentage differences from control.

Phytotoxic activity of phenolic derivatives

Compounds **20-24**, **29**, **39**, **40**, **44** have been tested for their activity on the seeds of *Lactuca sativa*. Aqueous solutions of the compounds ranging between 10^{-4} and 10^{-7} M, have been tested for the germination, root length and shoot length of treated lettuce seeds (**figure 22**). Compounds **21**, **28**, **38**, **39**, **40** and **44** have been tested also at concentration 10^{-8} M and 10^{-9} M. The *p*-methoxy-benzoic acid (**20**) reduces the germination by 20% at 10^{-4} M in respect to the control (**figure 22A**). Compound **21**, differing from compound **23** for the relative position of the substituents on the ring, shows an inhibiting activity of 25% on germination, while compound **23** is inactive at all the tested concentrations. Compounds **28** and **38** inhibit germination by the 20% at concentrations 10^{-4} M and 10^{-7} M, respectively. Compounds **29**, **39** and **44** have a really weak effect on germination. Among the tested compounds only **20** has a strong effect of about 40% on root length, while **21**, **28**, **40** and **44** inhibit root growth by about 20% (**figure 22B**). Activity of 20- 25% on the shoot length at 10^{-4} M has been observed for compounds **20**, **23**, **28** and **29** in respect to the control (**figure 22C**).



A

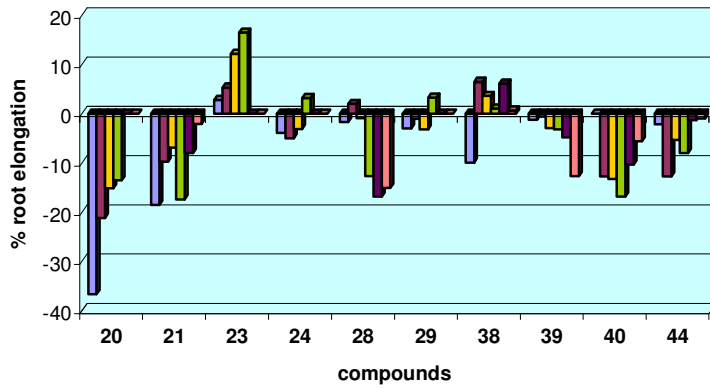

B

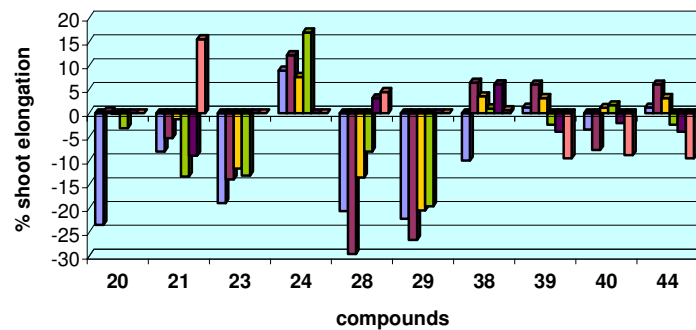

C

■ 10(-4) M ■ 10(-5) M ■ 10(-6) M ■ 10(-7) M ■ 10(-8) M ■ 10(-9) M

figure 22 - Effect of compounds 20, 21, 23, 24, 28, 29, 38, 39, 40 and 44 on germination, root length and shoot length of *Lactuca sativa* L. (A). Values presented as percentage differences from control.

CONCLUSIONS

During the three years of my PhD studies three Mediterranean plants have been analysed, *Brassica fruticulosa*, *Chenopodium album* and *Malva silvestris*.

Two different extracting procedures have been used to obtain plant-produced secondary metabolites. *Brassica fruticulosa* and *Chenopodium album* have been treated by infusion procedure with an hydroalcoholic solution (10% MeOH/H₂O) and then methanol. *Malva silvestris* has been extracted by using an automatic extractor (extractor Naviglio) (Naviglio 2003) that executes a series of working cycles of compression and decompression of the solid matrix, leading to metabolites release.

The extracts obtained have been concentrated and fractionated by different chromatographic techniques (CC, TLC, HLPC, DCCC), while the structural characterisation of pure compounds has been performed by spectroscopic and spectrometric techniques (¹H and ¹³C NMR, UV, IR, CD, ESI MS, MALDI MS, GC MS).

The investigation of the three Mediterranean plants has led to the identification of: seven lignans (**1-5**, **47**, **48**), four neolignans (**6-10**), five sesquilignans (**12**, **13**, **49-51**), one dilignan (**11**), eight C-13 *nor*-terpenes (**14-18**, **33-35**), three degraded carotenoids (**60-62**), two monoterpenes (**30**, **31**), one sesquiterpene (**32**), one diterpene (**36**), nineteen phenol derivatives (**19-29**, **37-44**), one triptamine (**46**), one benzaldehyd derivative (**45**), three allenes (**64-66**) and eight cinnamic amides (**52-59**).

The two neolignans **8** and **9**, the sesquilignans **12** and **13**, the dilignans **50** and **51**, the cinnamic amide **58**, the alkaloidic derivative of the cinnamic amide **59**, the norterpenes **15**, the two apo-carotenoids **60** and **61**, the sesquiterpene **32** and the diterpene **36** have been isolated for the first time.

Absolute stereochemistry of compounds **15**, **16** and **36** has been defined through the application of Mosher's method (Othani *et al.* 1991).

Some of the isolated compounds have been tested on seeds of standard plants (*Lactuca sativa* L. (lettuce), *Lycopersicon esculentum* M. (tomato), *Allium cepa* L. (onion)) to evaluate biological activity. The assays have been run in accordance with the procedures optimized by *Macias et al. (2000)*.

The results reported have shown a strong inhibiting effect of many lignans, which inhibit germination and growth of the standard species down to 1 nM concentration. At these concentrations commercial herbicides are usually inactive. Such a potent bioactivity for very diluted solution of lignans suggests further *in vitro* and in fields investigations, to fully evaluate the potential use of these molecules as natural herbicides.

Monoterpene **30** is significantly bioactive, inhibiting germination of *Lactuca sativa* by 90% at 10^{-4} M. Linalool is widely produced by many plants and trees, which are used as commercial sources of this monoterpene, employed as fragrance in cosmetics and essential oils. Moreover linalool is a well-known insecticide, in fact it is a contact poison that heightens sensory nerve activity in insects, causing massive over-stimulation of motor nerves that leads to convulsion and paralysis. When applied topically to some laboratory animals, linalool can irritate the skin, eyes and mucous membranes. However, the symptoms are usually temporary, lasting from several hours to several days, and the animals usually recover their vital functions fully. Recent studies have proved the ecological role of linalool. Many plants producing linalool have been demonstrated to have an insect deterrent power. *Aharoni et al. (2003)* demonstrate that in choice assays aphids are deterred from *Arabidopsis* plants that constitutively produce high levels of linalool. Field experiments using wild tobacco species genetically modified for linalool overexpression (*Kessler et al. 2001*) show that linalool inhibits oviposition of moths. The results obtained on *Lactuca sativa* seeds suggest further investigation of linalool phytotoxic activity to fully understand the ecological role of this monoterpene and to evaluate its potential use as a herbicide.

The phytotoxic data presented enlighten the role covered by plant-originated compounds in the research of new eco-compatible herbicides. Natural substances still represent a fruitful field of investigation to detect unknown molecules having new structures and functionalities that evolution has refined for highly specific biological roles.

This thesis has also led to the identification and structural characterisation of some molecules having a new interesting carbon skeleton, that might contribute to the complicated process of discovery and definition of natural substances.

REFERENCES

- Aasen A. J., Hlubucek J. R., Enzel C.R., Tobacco chemistry. 24. (9R)-9- hydroxy-4-megastigmen-3-one, a new tobacco constituent, *Acta Chem. Scand. B* **1974**, 28, 285-288.
- Abe F., Yamauchi T. Tanegosides A, B and C lignan glycosides from *Trachelospermum liukiunense*. *Chem. Pharm. Bull.* **1990**, 38, 2143-2145.
- Adesina S. K., Reish J. Amides from *Zanthoxylum rubescens*. *Phytochemistry* **1989**, 28, 839-842.
- Aharoni A *et al.* Terpenoid metabolism in wild-type and transgenic *Arabidopsis thaliana* plants. *Plant Cell* , **2003**, 15, 2866-2884.
- N. L. Allinger, Y. H. Yu, *Quantum Chem. Prog. Exchange* **1980**, 12, 395.
- Aliotta G., Cafiero G., De Feo V., Sacchi R., Potential allelochemicals from *Tuta graveolens* L. and their action on radish seeds. *J.Chem.Ecol.*, **1994**, 11, 2761-2775.
- Amster J., Fourier Transform Mass Spectrometry. *Journal of mass spectrometry*,**1996**, 31, 1325-1337.
- Anon J., *J. Chem.Ecol.*, **2001**, 27, preface.
- Arnoldi A., Merlini L. Asymmetric synthesis of 3-methyl-2-phenyl-1,4-benzodioxanes. Absolute configuration of the neolignans Eusiderin and Eusiderin C and D. *J Chem Soc Perkin Trans I*: **1985**, 2555-2557.
- Baumeler A., Brade W., Haag A., Eugster C. H., Synthese von enantiomereinen 'Grasshopper'- ketonen und verwandten verbindungen, *Helv. Chim. Acta* **1990**, 73, 700-718.
- (a) Behr D., Wahlberg I., Nishida T., Enzell C.. *Acta Chem. Scand. B* **1978**, 32, 391-394. (b) Sefton M. A., Skouroumounis G. K., Massy-Westropp R. A., Williams P. J. *Aust. J. Chem.* **1989**, 42, 2071-2084.

- Blum U., Designing laboratory plants debris-soil bioassays: some reflections. In: Inderjit, Dakshini KMM, Einhelling FA (eds), *Principles and practices in plant ecology: allelochemicals interactions*, CRC Boca Raton, **1999**, 17-23.
- Bohlmann F, Zdero C. 1977. Naturally occurring terpenes derivatives. 80. Some constituents of the genus *Chronolaena*. *Chemische Berichte 110*: 487-490.
- Briggs LH, Cambie RC, Couch AF. Lirioresinol-C dimethyl ether, a diaxially substituted 3,7-dioxabicyclo[3.3.0]-octane lignan from *Macropiper excelsum* (Forst. f.). *J Chem Soc (C)*, **1968**, 3042-3045.
- Britton G., *Carotenoids Vol.1B*, Britton G., Liaaen-Jensen S., Pfander H., Eds, Birkhauser, Basel, **1995**, 13-62.
- Carro MN, Lopez TE, Garcia JCM. Contribution to the study of the aromatic potential of three Muscat *Vitis vinifera* varieties: identification of new compounds. *Food Science and Technology International* **1995**, 1, 105-116.
- Clardy J., Walsh C., Lessons from natural molecules, *Science*, **2004**, 432, 829-837.
- Cuttillo F., D'Abrosca B., Della Greca M., Di Marino C., Golino A., Previtiera L., Zarrelli A., Cinnamic acid amides from *Chenopodium album*: effects on seed germination and plant growth. *Phytochemistry*, **2003**, 64, 1381-1387.
- Cuttillo F., D'Abrosca B., Della Greca M., Fiorentino A., Zarrelli, A.. Lignans and neolignans from *Brassica fruticulosa*: Effects on seed germination and plant growth. *J.Agric.Food Chem.*, **2003**, 51, 6165-6172.
- Cuttillo F., D'Abrosca B., Della Greca M., Zarrelli A., Chenoalbicin, a novel cinnamic acid alkaloid from *Chenopodium album*. *Chemistry and biodiversity*, **2004**, 1, 1579-1583.
- Cuttillo F., Della Greca M., Previtiera L., Zarrelli A., C-13 Norisoprenoids from *Brassica fruticulosa*. *Natural Product Research*, **2005**, 19, 99-103.
- Cuttillo F., Della Greca M., Gionti M., Previtiera L., Zarrelli A., Phenols and lignans from *Chenopodium album*. *Phytochemical Analysis*, article in press.

- D'Abrosca B., DellaGreca M., Fiorentino A., Monaco P., Oriano P., Temussi F. Structure elucidation and phytotoxicity of C₁₃ nor-isoprenoids from *Cestrum parqui*. *Phytochemistry* **2004**, *65*, 497-505.
- Dale J. A. and Mosher H. S., Nuclear magnetic resonance enantiomer reagents. Configurational correlations via nuclear magnetic resonance chemical shifts of diastereoisomeric mandelate, O-methylmandelate, and α -methoxy- α -trifluoromethylphenylacetate (MPTA) esters, *J. Am. Chem. Soc.* , **1973**, *95*, 512-519.
- D'Arcj B.R., Rintoul G.B., Rowland C. Y., Blackman A. J., Composition of Australian Honey Extractives. 1. Norisoprenoids, Monoterpenes, and Other Natural Volatiles from Blue Gum (*Eucalyptus leucoxydon*) and Yellow Box (*Eucalyptus melliodora*) Honeys, *J. Agric. Food Chem.* **1997**, *45*, 1834-1843.
- Della Greca M., Molinaro A., Monaco P., Previtiera L., Neolignans from *Aurum italicum*, *Phytochemistry*, **1994**, *35* (3), 777-779.
- Della Greca M, Monaco P, Pinto G, Pollio A, Previtiera L, Temussi F. Phytotoxicity of low-molecular weight phenols from olive mill waste waters. *Bull Environ Contam Toxicol* **2001**, *67*, 352-359.
- Della Greca M, Fiorentino A., Isidori M, Previtiera L., Temussi F, Zarrelli A, Benzocoumarins from rhizomes of *Juncus acutus*, *Tetrahedron*, **2003**, *59*, 4821-4825.
- Della Greca M., Di Marino C., Zarrelli A., D'Abrosca B. Isolation and phytotoxicity of apocarotenoids from *Chenopodium album*. *J. Nat. Prod.* **2004**, *67*, 1492-1495.
- Della Greca M, Isidori M, Lavorgna M, Monaco P, Previtiera L, Zarrelli A., Bioactivity of phenantres from *Juncus acutus* on *Selenastrum capricornutum*, *J. Chem.Ecol.*, **2004**, *30*, 867-870.
- Duke S.O., Lydon J., Herbicides from natural compounds, *Weed technol.* **1987**, *1*, 122-128.
- Ehmann A., *N*-(*p*-Coumaryl)-tryptamine and *N*-ferulyl-tryptamine in kernels of *Zea mays*. *Phytochemistry* **1974**, *13*, 1979-1983.

- Einhellung F.A., Rice E.L., Risser P.G., Wender S.H., Effects of scopoletin on growth, CO₂ exchange rates, and concentration of scopoletin, scopolin and chlorogenic acids in tobacco, sunflower and pigweed, *Bull Torrey Bot Club*, **1970**, *97*, 22-33.
- Einhellung F.A., Mechanism and modes of action of allelochemicals, In A Putnam, CS Tang, eds, *The science of allelopathy*, John Wiley and sons, Inc., New yprk, NY, 171-188, **1986**.
- Einhellung F.A., The physiology of allelochemical action: clues and views, *First European Allelopathy Symposium*, Vigo, Spain, June 21-23, **2001**..
- Fang J, Lee C, Cheng Y. Lignans from leaves of *Juniperus chinensis*. *Phytochemistry*, **1992**, *31*, 3659-3661.
- Fonseca S. B., De Paiva Campello J., Barata L. E. S., Ruveda E. A. ¹³C-NMR analysis of lignans from *Araucaria augustifolia*. *Phytochemistry*, **1978**, *17*, 499-502.
- Fraga B. M., Hernandez M. G., Mestres T., Terrero D. and Arteaga J. M.. Nor-sesquiterpenes from *Teucrium heterophyllum*, *Phytochemistry*, **1995** *39*, 617-619.
- Harada N., Nakanishi K. *Circular Dichroic Spectroscopy*, University Science Books, Oxford University Press, **1983**, 240-243.
- Hess F. D., Bayer D. J. Binding of herbicide trifluralin to *Chlamydomonas* flagellar tubulin. *J. Cell. Sci.* **1977**, *15*, 351-360.
- Hlubucek J. R., Hora J., Russell S. W., Toubé T. P., Weedon B., Carotenoids and related compounds. Part XXIX. Stereochemistry and synthesis of the allenic end group. Absolute onfiguration of zeaxanthin, *J. C. S. Perkin Trans I* **1974**, 848-852.
- Horio T., Yoshida K., Kikuki H., Kawabata J., Mizutani J., A phenolic amide from roots of *Chenopodium album*, *Phytochemistry* **1993**, *33*, 807-808.
- Houghton P. J. Lignans and neolignans from *Buddleja davidii*. *Phytochemistry* **1985**, *24*, 819-826.
- Huang J., Ogihara Y., Gonda R., Takeda T. Novel Biphenyl ether lignans from rhizomes of *Curcuma chuanyujin*. *Chem. Pharm. Bull.* **2000**, *48*, 1228-1229.

- Hussain S. F., Gözler B., Shamma M., Gözler T.. Feruloyltyramine from *Hypocoum*. *Phytochemistry* **1982**, *21*, 2979-2980.
- Inderjit, Nielsen E.T., Bioassays and field studies for allelopathy in terrestrial plants: progress and problems, *Crit Rev Plant Sci*, **2003**, *22*, 221-238.
- Inderjit, Weston L.A., Root exudates: an overview. In *Root Ecology*, H. de Kroon and Visser E.J.W. (eds.), 235-255, Springer, Heildenberg, **2003**.
- Inderjit, Callaway R.M., Experimental designs for the study of allelopathy, *Plant and soil*, **2003**, *256*, 1-11.
- Inderjit, Duke S.O., Ecophysiological aspects of allelopathy, *Planta*, **2003**, *217*, 529-539.
- Kessler A., I. T. Baldwin, Defensive Function of Herbivore-Induced Plant Volatile Emissions in Nature, *Science*, **2001**, *291*, 2141.
- Kinjo J, Higuchi H, Fukui K, Nohara T.. Lignoids from *Albizziae cortex*. II. A biodegradation pathway of syringaresinol. *Chem Pharm Bull*, **1991**, *39*, 2952-2955.
- Knudsen CG, Lee DL, Michaely WJ, Chin HL, Nguyen NH, Rusay RJ, Cromartie TH, Gray R, Lake BH, Fraser TEM, Cartwright D, Discovery of the triketone class of HPPD inhibiting herbicides and their relationship to naturally occurring b-triketones. In SS Narwal, RE Hoagland, RH Dilday, MJ Reigosa, eds, *Allelopathy in ecological agriculture and forestry*, Kluwer academic publishers, The Netherlands, **2000**, 101-111.
- Kuima K., Otzuka H., Ide T., Ogimi C., Hirata E., Takushi A., Takeda Y. Sesquiterpene glycosides and sesquilignan glycosides from stems of *Alangium premnifolium*. *Phytochemistry* **1998**, *48*, 669-676.
- Lavie D, Levy E. C., Cohen A., Evenari M., Gutterman Y. New germination inhibitor from *Aegilops ovata*. *Nature* **1974**, *249*, 388.
- Lee D.L., Prisbylla M.P., Cromartie T.H., Dagarin D.P., Howard S.E., Provan W.M., Ellis M.K., Fraser T., Mutter L.C., The discovery and structural requirements of inhibitors of p-hydroxyphenylpyruvate dioxigenase, *Weed Sci*, **1997**, *45*, 95-102.

- Li S., Lundquist K., Wallis A. F. A. Revised structure for a neolignan from *Brucea javanica*. *Phytochemistry* **1998**, *49*, 2125-2128.
- Lin-gen, Z., Seligmann, O., Jurcic, K. K., Wagner, H. Constituents of *Daphne tangutica*. *Planta Med.* **1982**, *45*, 172-176.
- Lunz A., Winterhalter P., Isolation of additional carotenoid metabolites from quince fruit (*Cydonia oblonga* Mill.), *J. Agric. Food Chem.* **1992**, *40*, 1116-1120.
- Macias F. A., Torres A., Varela R., Molinillo J. M. G., Castellano, D. Bioactive flavonoids from *Helianthus annuus* cultivars, *Phytochemistry* **1997**, *45*, 683-687.
- Macias F.A., Molinillo, Varala, Torres, Galindo, Bioactive compounds from genus *Helianthus*, In Macias, Galindo, Molinillo, Cutler, eds, Recent advanced in allelopathy, Vol. 1: A science for the future, Servicio de publicaciones, Universidad de Cadiz, Cadiz, Spain, 121-167, **1999**.
- Macias F. A., Castellano D., Molinillo J. M. G.. Search for a standard phytotoxic bioassay for allelochemicals. Selection of standard target species. *J. Agric. Food Chem.* **2000**, *48*, 2512-2521.
- MacRae W. D., Towers G. H. Biological activities of lignans. *Phytochemistry* **1983**, *23*, 1207-1220.
- Mahall B.E., Callaway R.M., Root communication mechanism and intracommunity distribution of two Mojave desert shrubs, *Ecology*, **1992**, *73*, 2145-2151.
- Mallik M. A. B., Puchala R., Grosz F. A., A growth inhibitory factor from lambsquarters (*Chenopodium album*), *J. Chem. Ecol.* **1994**, *20*, 957-967.
- Matsuda S., Kadota, S., Tai T. Isolation and structures of hedyotisol-A, -B, and -C novel dilignans from *Hedyotis lawsoniae*. *Chem. Pharm. Bull.* **1984**, *32*, 5066-5069.
- Mizutani J. Select allelochemicals. *Critical Reviews in Plant Sciences* **1999**, *18*, 221-223.
- Molisch H., Der einfluss einer pflanze auf die andere-Allelopathie, Fisher, Jena, **1937**.

- Mori K. Carotenoids and degraded carotenoids. IV. Syntheses of optically active grasshopper ketone and dehydrovomifoliol as a synthetic support for the revised absolute configuration of (+)-abscisic acid. *Tetrahedron* **1974**, *30*, 1065-1072.
- Moro GA, Graziano MN, Coussio JD.. Alkaloids of *Prosopis nigra*. *Phytochemistry* **1975**, *14*, 827-830.
- Muller WH, Volatile materials produced by *Salvia leucophylla*: effects on seedling growth and soil bacteria, *Bot.Gaz.*, **1965**, *126*, 195-200.
- Naviglio D. Naviglio's principle and presentation of an innovative solid-liquid extraction technology: extractor Naviglio. *Analytical Letters*, **2003**, *36*, 1647-1659.
- Nicoletti, M., Tommassini, L., Serafini, M. Two linalool-1-oic acids from *Kickxia spuria*. *Fitoterapia* **1989**, *60*, 252-254.
- Oliva A., Moraes R. M., Watson S. B., Duke S. O., Dayan F. E. Aryltetralin lignans inhibit plant growth by affecting the formation of mitotic microtubular organizing centers. *Pesticide Biochem. Physiol.* **2002**, *72*, 45-54
- Ohtani I., Kusumi T., Kakisawa H., High-field FT-NMR application of Mosher's method. The absolute configurations of marine terpenoids, *J. Am. Soc.* , **1991**, *113*, 4092-4096,
- Prestwich G. D., Whitfield F. B., Stanley G., Synthesis and structures of dihydroedulan I and II. Trace components from the juice of *Passiflora edulis* Sims. *Tetrahedron* **1976**, *32*, 2945-2948
- Reigosa M.J., Sanchez-Moreiras A., Gonzales L., Ecophysiological approach in allelopathy, *Critical Rev. Plant Sci.*, **1999**, *18*, 197-207.
- Rice E.L. , *Allelopathy*, Academic press, Orlando, Florida, **1984**.
- Richard G. A., Hussey P. J. Dinitroaniline herbicides resistance and the microtubule cytoskeleton. *Trends Plant Sci.* **1999**, *4*, 112-116.
- Rimando A.M., Dayan F.E., Czarnota M.A., Weston L.A., Duke S.O., A new photosystem II electron transfer inhibitor from *Sorghum bicolor* L., *J.Nat. Products*, **1998**, *61*, 927-930.

- Rimando A. M., Dayan F. E., Mikell J. R., Moraes R. M. Phytotoxic lignans of *Leucophyllum frutescens*. *Nat. Toxins* **1999**, 7, 39-43.
- Romagni J.G., Duke S.O., Dayan F.E., Inhibition of plant asparagine synthetase by monoterpene cineoles, *Plant Physiol.*, **2000**, 123, 725-732.
- Russel G. B., Singh P., Fenemore P. G. Insect-control chemicals from plants. Toxic lignans from *Libocedrus bidwillii*. *Aust. J. Biol. Sci.* **1976**, 29, 99-103.
- Sebeson J. M., Mitchell E., Snyder F. W. Effect of phenolic acids on alpha-amylase in vitro and early growth of sugar beet. *Journal of the American Society of Sugar Beet Technologists* ,**1969**, 15, 556-561.
- Shabana E. F., Battah M. G., Kobbia I. A., Eladel H. M. Effect of pendimethalin on growth and photosynthetic activity of *Protosiphon botryoides* in different nutrient states. *Ecotox. Environ. Safety* **2001**, 49, 106-110.
- Shiraga, Y., Okano, K., Akira, T., Fukaya, C., Yokoyama, K., Tanaka, S., Fukui, H., Tabata, M., Structures of potent antiulcerogenic compounds from *Cinnamon cassia*, *Tetrahedron* **1988**, 44, 4703-4711.
- Straus C. R., Dimitriadis E., Wilson B. , Williams P. Studies on the hydrolysis of two megastigma-3,6,9-triols rationalizing the origins of some volatile C13 norisoprenoids of *Vitis vinifera* grapes, *J. J. Agric. Food Chem.* **1986**, 34, 145-149.
- Szabo M, Garay A. Changes in phenolics during the germination of *Arctium lappa* with special respect to arctiine. *Acta Bot. Acad. Sci. Hung.* **1970**, 16, 207.
- Suzuki T., Holden I., Casida J.. Diphenyl ether herbicide remarkably elevate the content in *Spinacia oleracea* of (*E*)-3-(4-hydroxy-3-methoxyphenyl)-*N*-[2-(4-hydroxy-3-methoxyphenyl)ethyl]-2-propenamide. *J. Agric. Food Chem.* **1981**, 29, 992-995.
- Takayuki S, Shinji O, Kiyotaka M, Nagatoshi I, Masako K, Masahiro S. Endogenous pine wood nematocidal substances in pines, *Pinus massoniana*, *P. strobus* and *P. palustris*. *Phytochemistry* **1993**, 33, 1395-1401.

- Takeshi D., Takako I., Shizuka K., Sansei N. The constituents of *Eucommia ulmoides* OLIV. VI. Isolation of a new sesquilignan and neolignan glycosides. *Chem. Pharm. Bull.* **1987**, *35*, 1803-1807.
- Tanaka H., Nakamura, T., Ichino K., Ito K., A phenolic amide from *Actinodaphne longifolia*. *Phytochemistry* **1989**, *28*, 2516-2517.
- Teai T, Claude-Lafontaine A, Schippa C, Cozzolino F.. Volatile compounds in fresh pulp of pineapple (*Ananas comosus* [L.] Merr.) from French Polynesia. *Journal of Essential Oil Research*, **2001**, *13*, 314-318.
- Thompson L. U., Seidl M. M., Rickard S. E., Orcheson L. J., Fong H. H. Antitumorigenic effect of a mammalian lignan precursor from flaxseed. *Nutrition and Cancer* **1996**, *26*, 159-165.
- Urones J. G., De Pascual, Teresa, J., Sanchez Marcos, I., Diez Martin, D. *Ent-isolariciresinol* in *Reseda suffruticosa*. *Phytochemistry* **1987**, *26*, 1540-1541.
- Weidenhamer J.D., Romeo J.T, Distinguishing resource competition and chemical interference: overcoming the methodological impasse, *Agron. J.* **1989**, *88*, 866-875.
- Weiss G., Koreeda M., and Nakanishi K. , Absolute configuration of natural (+)-abscisic acid, *J. Amer. Chem. Soc.*, **1973**, *16*, 565-566.
- Willis R.J., The historical basis of the concept of allelopathy, *J.Hist. Biol.*, **1985**, *18*, 71-102.
- Yoshihara T., Katsuyoshi Y., and Sakamura S. A lignan stress compound in potato infected with nematode (*Globodera rostochiensis*). *Agric. Biol. Chem.* **1982**, *46*, 853-854.
- Yoshikawa K., Kageyama H., Arihara S. Phenolic glucosides and lignans from *Ehretia ovalifolia*. *Phytochemistry* **1995**, *39*, 659-664.
- Yoshikawa M., Shimada H., Saka M., Yoshizumi S., Yamahara J., and Matsuda H., Absolute stereostructures of corchoionosides A, B, and C, histamine release inhibitors from the leaves of Vietnamese *Corchorus olitorius* L. (*Tiliaceae*), *Chem. Pharm. Bull.*, **1997**, *45*, 464-469

- Yuen M. S. M., Xue F., Mak T. C. W., Wong H. N. C. On the absolute structure of optically active neolignans containing a dihydrobenzo[*b*]furan skeleton. *Tetrahedron* **1998**, *54*, 12429-12444.

FTICR: Fourier Transform Ion Cyclotron Resonance. Investigation upon the charge state, conformation and RS20 interaction of Calmodulin.

(Marie Curie project into the Improving Human Potential research programme).

Introduction

In the last forty years mass spectrometry has become one of the most used techniques for structural characterisation. The technique was born over a century ago, when the Nobel prize-winning physicist J.J. Thomson created the first mass spectrometer. Early mass spectrometers were massive, arcane instruments capable of analyzing only small, stable, volatile compounds. Although these original machines bear little resemblance to today's sophisticated models, the underlying principles are remarkably similar and simple. Then as now, molecules had to be vaporized in the vacuum of the mass spectrometer and then converted into charged ions. The ions, which may be broken into even smaller pieces called fragment ions, can be steered and focused by the magnetic, electrostatic, and radiofrequency fields used as lenses within the mass analyzer. The ionized molecule's mass and charge together determine its trajectory.

The improvement of the ionisation and analysing procedures has widened the range of application of mass spectrometry, and increased the information provided by a mass spectrum. The first ionisations techniques (EI, CI) only allowed the study of very volatile compounds, and did not assure molecules would not be broken in the process. With the incoming of soft ionisation instruments (FAB, MALDI, ESI) also high polar and labile molecules became good targets for spectrometric investigation. Even proteins that with the earlier ionization protocols were often destroyed before they could be effectively ionized, began to be manageable for focusing in a detectable spectrum. Since then, protein study has become one of the most successful fields of investigation by mass spectrometric techniques.

A recent breakthrough that has further increased mass spectrometry potential is the correlation between the number of charges that a macromolecule possesses and its three-dimensional

structure. In fact it is a commonly accepted assumption that the ESI ionisation allows a macromolecule such as a protein to be vaporised, while preserving the tertiary structure it has in solution (*Gaskell et al. 1997*). That implies the possibility of studying non-covalent complexes between proteins, or proteins and peptides in solution. The ESI ionisation allows the systematic study of enormous molecules to be performed, only by interfacing an ESI source to a suitable mass spectrometer analyser, having features of high resolution, sensitivity and mass accuracy.

Depending on the required parameters of mass accuracy and resolution, the kind of ionisation method used and the mass range submitted to analysis, different mass analysers can be chosen.

FT-ICR Mass Spectrometry

During the past decade a new mass spectrometer has received increasing interest due to its features of ultra-high resolution and mass accuracy: the Fourier transform ion cyclotron resonance (FT-ICR) mass spectrometer (*Barrow et al. in press*).

FT-ICR mass spectrometry (fig.1a) is a very versatile technique that can be employed with practically every known ionisation procedure to perform high-resolution mass spectra, tandem mass spectrometric measurements, and to examine chemistry and photochemistry of ions.

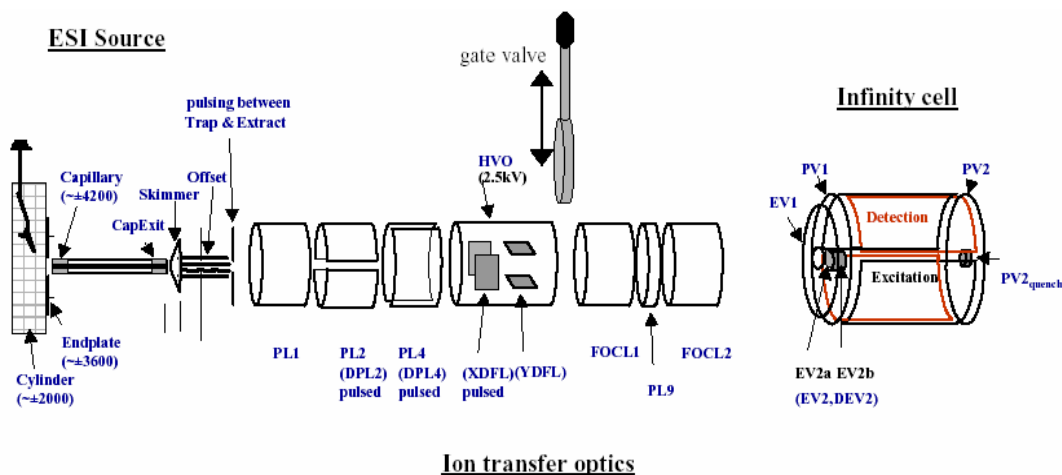

Fig. 1a- FTICR with ESI source

Instrument working is based on the possibility of inducing and detecting the cyclotronic motion of an ion population generated in the ionisation chamber, whose circular frequency is an inverse function of the mass to charge ratio of the ions (fig.2a). Thus the time-domain spectrum obtained by measuring the circular motion of the ions is converted through the mathematical function of Fourier transformation into a frequency-domain spectrum. The mathematical correlation existing between the frequency of the ions and their mass to charge ratio, provides the mass spectrum.

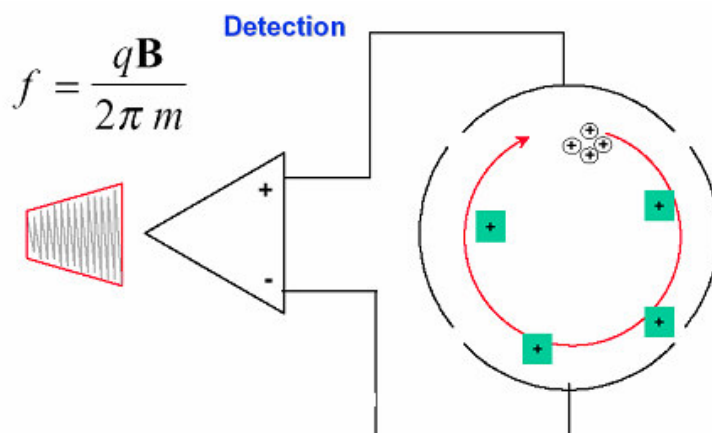

Fig 2a-Cyclotronic motion inducing an image current.

A fundamental component of an FTMS instrument is a magnet, which can be a permanent magnet, an electromagnet or a superconducting magnet. Since resolution is directly dependent on magnetic field strength, the common tendency is to resort to very strong magnetic fields by using superconducting magnets.

In the FTMS instruments ions produced by an external source are driven by a system of optics (fig. 1a) having a selected potential to the analyser cell (Infinity cell), where ions are stored, and mass analysed and detected. Analyser cells are composed of six metallic plates arranged in the shape of a cube, coupled in pairs through an external electric circuit (fig.3a). The cell is oriented in the magnetic field so that one couple of opposite plates is orthogonal to the

magnetic field lines, while the remaining two lie parallel to the field. The trapping plates are perpendicular to the magnetic field, the application of a variable potential to these plates allows the entrance and the accumulation of the ions in the cell for the required time. The other two couples of plates are used for ion excitation and detection.

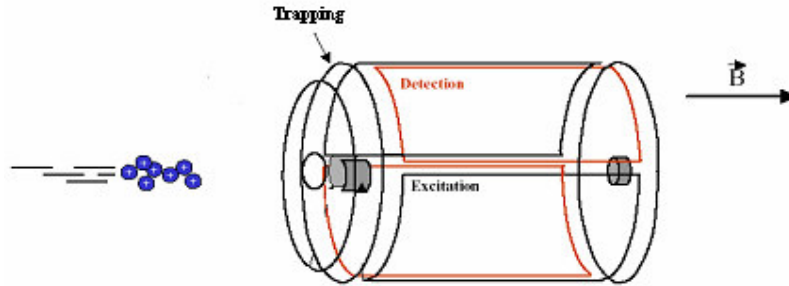

Fig 3a-Infinity cell

In the analyser cell the ions experience a force due to the action of the magnetic field which is perpendicular to ion velocity and to magnetic field lines (fig 4a). This force, called the Lorentz force, causes an ion to travel in a circular orbit that is perpendicular to the magnetic field.

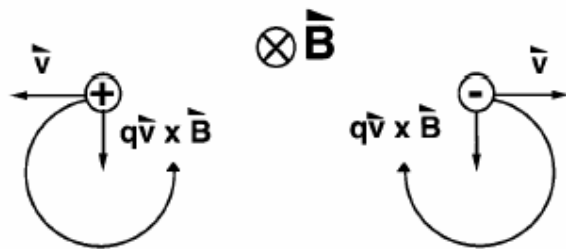

Fig. 4a-Lorentz force on a charged particle.

Cyclotron motion is periodic and is characterised by its cyclotronic frequency, which is the frequency with which an ion repeats its orbit. The cyclotron frequency is a function of the strength of the applied magnetic field B , of the charge q and the mass of an ion m , according to the equation 1:

$$f_c = qB / 2\pi m$$

eq.1

In FTMS the magnetic field is kept constant, therefore the measurement of the cyclotronic frequency directly provides the mass to charge ratio of the ion.

Having arrived in the Infinity cell the charged particles start a chaotic motion on circular orbits which have a radius too small to be detected. To obtain an intelligible signal, ions must be excited to detectable radii, and that occurs through the application of a radiofrequency potential through the two excitation plates. When ions are irradiated by a radiofrequency that is coincident to their cyclotronic frequency, they absorb energy and start to move coherently into a larger orbit. All the ions having the same mass to charge ratio are excited contemporaneously to form a packet of rotating ions, whose motion generates an alternating current detected by two electrodes, the detection plates. The experiments are usually conducted by applying a rapid frequency sweep that performs the excitation of a wide range of ions having different mass to charge ratios. The image current obtained is a composite of sinusoids of different frequencies and amplitudes. The Fourier transform of this time domain transient provides a frequency spectrum that is converted into a mass spectrum by applying a calibration formula derived from the cyclotron equation.

Mass resolution improves in direct proportion to the length of the transient that is recorded, according to equation 2, where f_c is the cyclotron frequency and T is the duration of the transient. The amplitude of the transient signal decays with time as collisions between the ions and neutrals in the analyser cell destroy the coherence of the ion packet. Thus FTMS requires an ultra-high vacuum in the cell, to minimize collision frequency.

$$R = f_c T / 2$$

eq.2

ESI and nano-ESI

Electrospray ionisation (fig.5a) is one of the most used ionisation techniques coupled to an FT-ICR mass spectrometer. As a low energy ionisation technique it can be safely applied to study labile molecules without risks of fragmentation. ESI frequently leads to the formation of multiply charged ions. As ions become more highly charged the m/z becomes lower and the space between the isotopomers (peaks due to the presence of other isotopes) becomes narrower. As a result it becomes more difficult to resolve signals and the resolution of the mass analyser becomes more important, considering that the charge state of an ion can be determined by examining the space between the isotopomers signals.

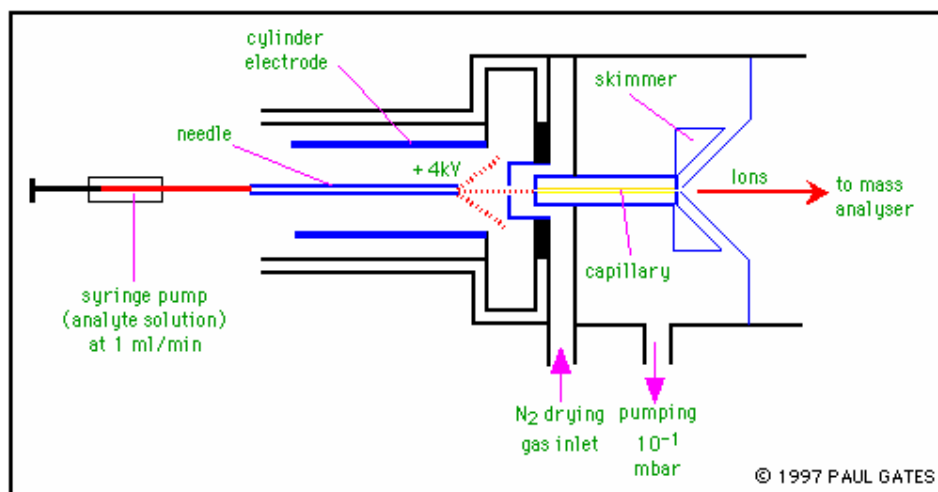

Fig. 5a-ESI instrumental setting.

The electrospray process (*Gaskell et al. 1997*) is realized using a capillary held at high potential, through which a solution of the analyte is passed. The capillary tip is very thin and is always kept at high potential. The application of a positive potential causes positive ions to accumulate on the surface solution, which is thus drawn out in a down field direction to establish a Taylor cone (fig.6a). When the imposed field is high enough the cone is stretched to a filament which produces positively charged droplets when the surface tension is exceeded

by the electrostatic applied field. The gradient of potential and of pressure that the droplets experience moving towards the analyser of the mass spectrometer causes the solvent evaporation and reduction of droplet diameters. When the internal charges repulsion is sufficient to overcome the surface tension holding the droplet together (Rayleigh limit), droplet fission occurs, generating droplets with smaller diameter. The reiteration of the described process finally produces a droplet containing a single ion, which after further evaporation releases the fully desolvated ion. Usually a bath gas is applied to the interface to promote droplet evaporation.

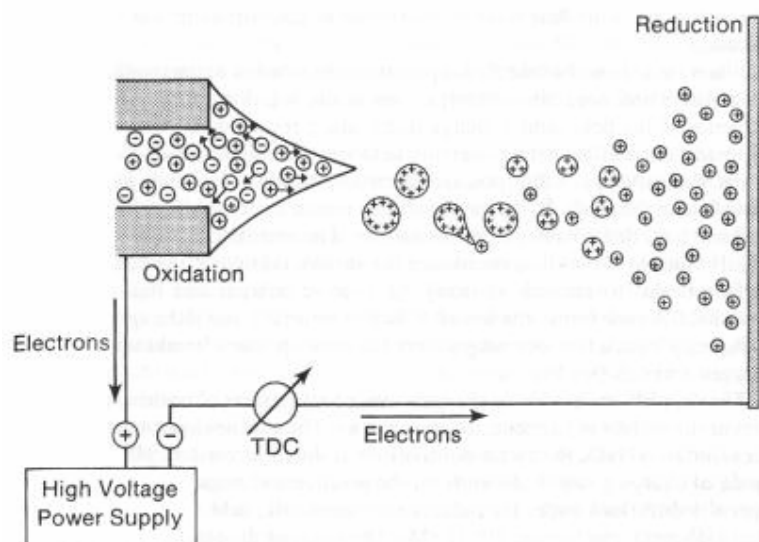

Fig.6a-Taylor cone and ions generation

The mechanism underlying electrospray ionisation determines the properties of the gas-phase ions generated. A really important feature of this ionisation technique is that the charge states of the gaseous ions reflect the charge states in the condensed phase.

Electrospray spectra of proteins detected at different pH show different discrete charge states distributions, which have been interpreted as corresponding to solution populations with different conformations. Different three-dimensional structures in fact can acquire a different number of charges depending on different availability of protonation sites. This observation

has been confirmed by experiments based on hydrogenous/deuterium exchange in condensed phase and in gas phase (*Wagner et al. 1994*).

Also non-covalent interactions existing between molecules in solution can be preserved during the ionisation process. Protein-ligand complexes can be successfully detected by a mass spectrometer composed of an ESI source coupled to an FT-ICR analyser (*Ganem et al. 1991*).

The sample solution flow rate in an electrospray interface is most commonly in the range of 3-20 $\mu\text{l} / \text{min}$. A recently developed electrospray ionisation technique is the nano-ESI (*Jurasheck et al. 1998*) which allows operation at very low flows of nl/min. The main advantage deriving from lower ionisation flows has been demonstrated to be the high efficiency of conversion of condensed-phase analyte to gas-phase. The application of low solvent flow generates very small droplets which after one or just a few offspring events release the solvent-free ions. ESI processes compared to nanoESI involve initial charged droplets of higher radius, thus a more elevated evaporation is required before reaching a sufficient charge density for fission. The result is the concentration increase of both analyte and salt in the droplets, which leads to cluster generation, and to more noisy mass spectra. These features cause nanoESI to be a technique which allows a cleaner spectrum from a less pure analyte to be obtained.

During the nine months I spent at Warwick University (UK) supported by a Marie-Curie fellowship, I benefited from the use of an FT-ICR mass spectrometer equipped with both a ESI and a nano-ESI source. In particular I have been studying the charge states distribution of Calmodulin and modalities of interaction of this protein in a biological environment.

Calmodulin structure and its biological rule

Calmodulin (CaM) is a small, highly conserved, calcium binding protein found in all eukaryotic cells. It is composed of 148 residues, bound to form a dumbbell shaped molecule with two globular domains linked by a short, flexible seven turn alpha-helix (fig.7a). Each

domain houses two calcium binding sites consisting of a loop-helix-loop structure with high calcium affinity.

This profile fits calmodulin as a calcium sensor protein and in fact calmodulin is involved in many calcium regulated signalling pathways that settle crucial processes such as growth, proliferation and movement. How calmodulin interacts with calcium and target proteins is a fundamental issue for enlightening signalling transmission pathways, but is still unclear. Calcium binding at specific EF hand sites induces conformational modification of the calmodulin structure that leads to the exposure of the hydrophobic protein residues to the solvent. These hydrophobic sites are able to link target peptides and consequently to activate proteins (*Chin et al. 2000*).

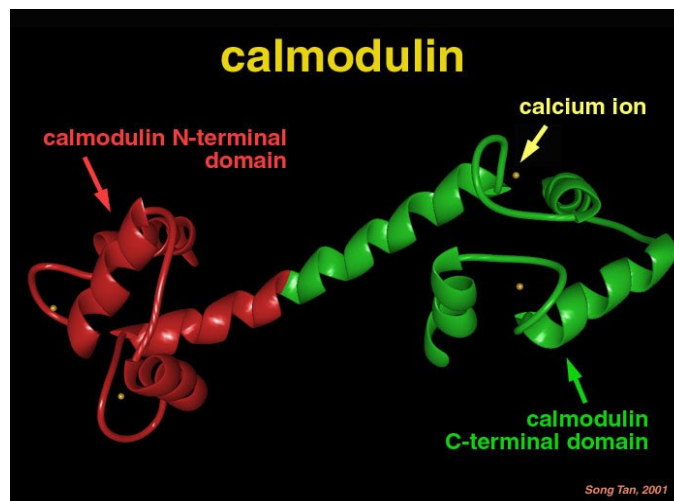

NH₂ADQLTDDEQIAFKEAFSLFDKDGGITITT⁽³⁰⁾KELGTVMRSLGQNPTEAELQDMI
NEVDADG⁽⁶⁰⁾NGTIDFPEFLNLMARKMKDTSSEEELKEAF⁽⁹⁰⁾RVFDKDGNGFISAAEL
RHVMTNLGEKLTDEEVDEMIREAD⁽¹³⁰⁾VDGDGQVYEEFVQVMMAK⁽¹⁴⁸⁾COOH

Fig.7a-Calmodulin primary and tertiary structures.

This mechanism does not seem to be the only one apt to describe the interaction between CaM and other CaM-binding peptides. The binding process of CaM with RS20 (a synthetic peptide analogue derived from the phosphorylation site of smooth muscle Myosin Light Chain

Kinase) has been described as involving the generation of a complex CaM-Ca₄ or CaM-Ca₂, followed by the bridging of the peptide between the N-terminal and C-terminal domains of CaM (Wintrobe *et al.* 1997).

Results and discussion

Calmodulin interaction with RS20 and calcium has been studied through FT-ICR mass spectrometry interfaced with both ESI and nano-ESI sources.

Calmodulin mass spectrum in figure 8a (Hill *et al.* 2000) has been registered in 5 mM ammonium acetate buffer, pH 5.9, in the absence of an organic solvent, using an ESI source. The monoisotopic mass experimentally determined is $16\,616.84 \pm 0.02$ Da, which agrees with the theoretical mass of the isotopically pure protein obtained from the sequence (16 616.82 Da) within experimental error.

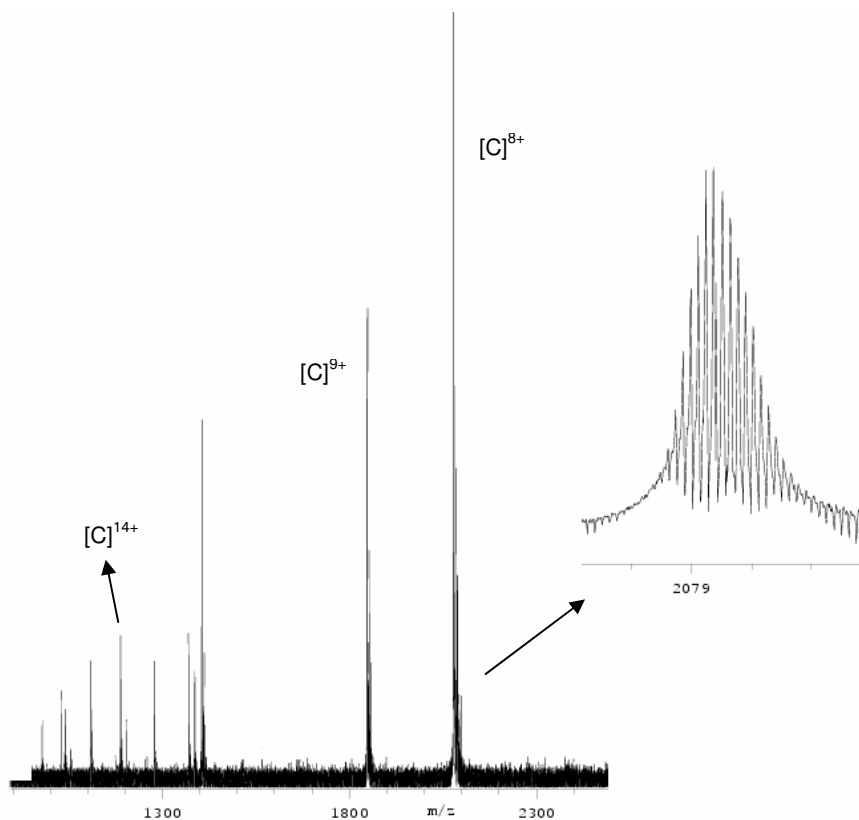

Fig.8a: ESI-FTICR mass spectra of calmodulin in ammonium acetate buffer. Inset shows the isotopically resolved pattern of the 8⁺ charge state.

Each peak has been assigned to calmodulin molecules ionized by a different number of protons. Thus, for example, [C]⁸⁺ represents [C+8H]⁸⁺ where calmodulin is the neutral protein. The spectrum shows two different charge-distribution patterns attributable to two different calmodulin conformations in buffer solution. The higher charge state distribution is centred around the 12⁺ charge state, and it is attributed to an unfolded conformation. The lower charge state envelope exhibits the main peak corresponding to eight attached protons, and it is proposed to correspond to a more compact calmodulin conformation.

Experimental data obtained spraying Calmodulin from methanol or acetonitrile/water solution confirm the hypothesised conformation attributions. Figure 9a shows the spectrum of calmodulin in organic solvent solution, which promotes the unfolding process of the protein.

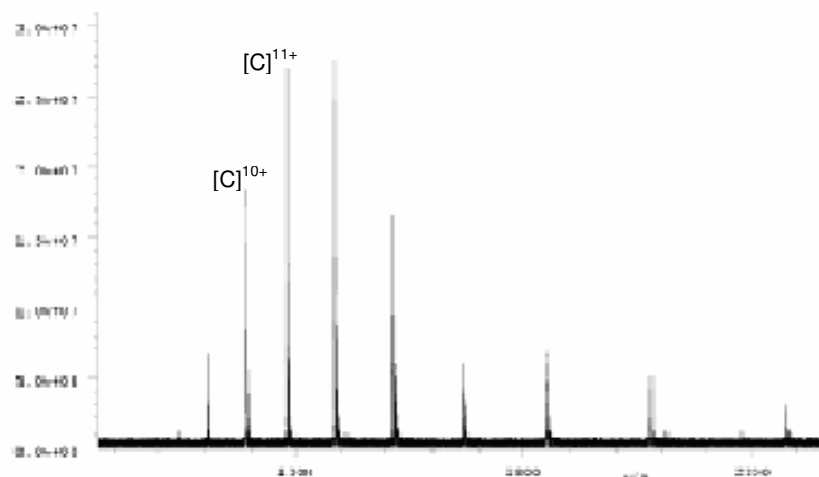

Fig.9a : ESI-FTICR mass spectra of calmodulin in CH₃CN/H₂O 1:1 and 1% formic acid.

The charge envelope has a maximum corresponding to 12 attached protons, according to a more open structure in denaturant conditions.

Switching from an ESI source to a nano-ESI, we obtain a calmodulin spectrum (fig.10a) in buffer solution with a charge state envelope focused around the main peak corresponding to a 7⁺ charge state.

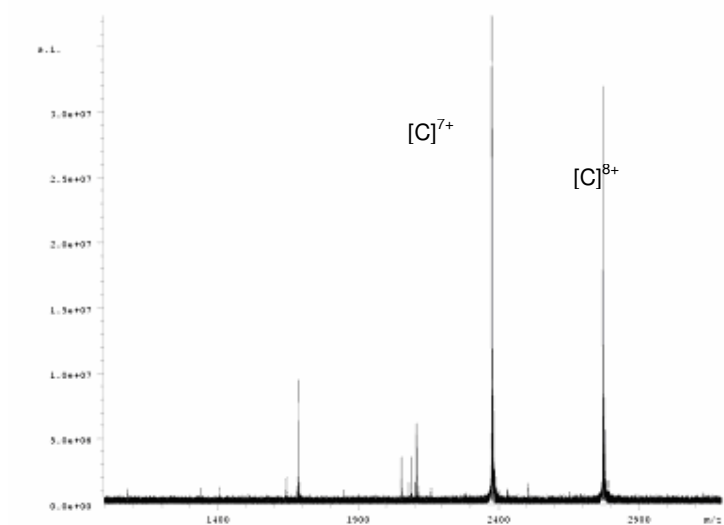

Fig.10a: nanoESI-FTICR mass spectra of calmodulin in ammonium acetate buffer.

Correlations between charge-state distribution pattern observed in ESI mass spectra and the equilibrium of protein conformation which exist in solution have been illustrated for other proteins (*Katta et al. 1991, Hamdam et al 1994, Loo et al. 1991, Feng et al. 1993*).

Mass spectra of the peptide RS20 in 5 mM ammonium acetate buffer show as the main species, the one with three attached protons [RS20+3H]⁺. The experimentally determined monoisotopic mass is 2293.293± 0.01 Da, in good agreement with theoretical mass of pure peptide.

The spectrum obtained from a calcium free solution containing CaM and RS20 in a concentration ratio 1:1.5, indicates the presence of a 1:1 calmodulin–RS20 complex, without any associated calcium ion (*Hill et al. 2000*) (fig 11a).

For example the signal at $m/z = 2103.46$ represents a species with a charge state of 9^+ and the correspondent mass of $18\,922.14 \pm 0.02$ Da, which is consistent to a CaM-RS20 complex. The presence of a complex between apocalmodulin and RS20 is unambiguous evidence of the binding of CaM to the target site of MLCK in absence of calcium (*Hill et al. 2000*).

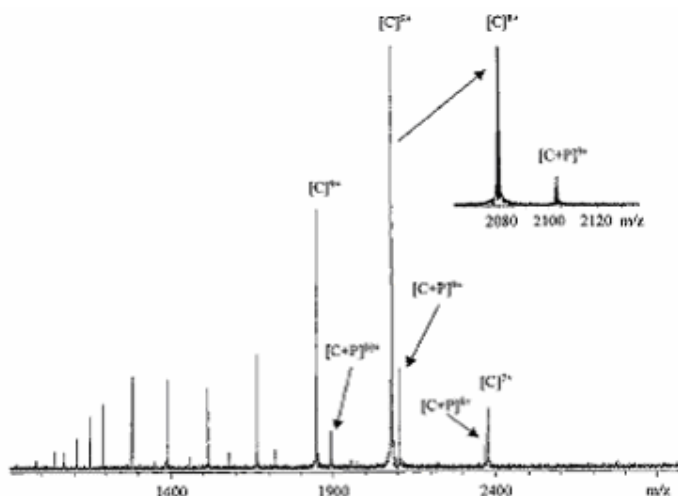

Fig.11a^h: ESI-FTICR mass spectra of calmodulin in ammonium acetate buffer in presence of RS20.

The spectrum obtained for a solution of calcium chloride and calmodulin (molar ratio 1:0.4) is not very different from that of apocalmodulin (fig12a.). The main species have not changed their charge-state, in fact the highest peak remains the 8^+ . Calcium binding is observed with one, two, three and four calcium ions found for each charge state.

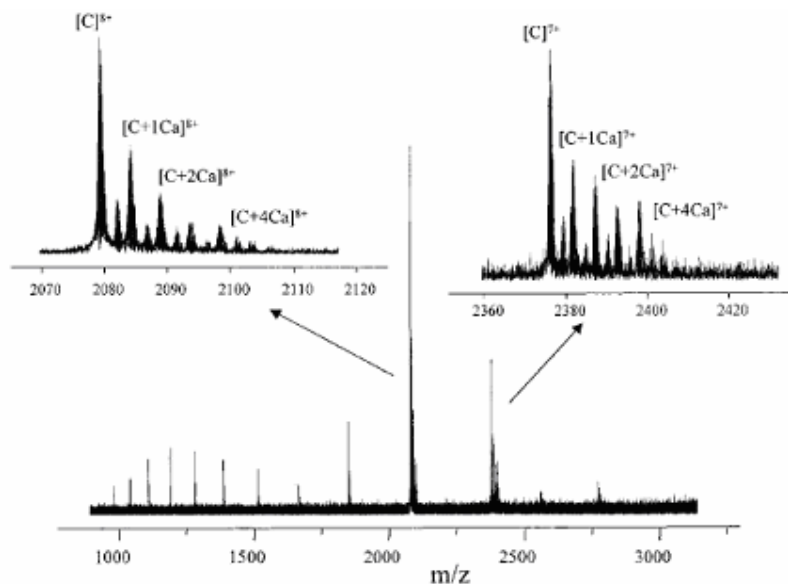

Fig. 12a: ESI-FTICR mass spectra of calmodulin in ammonium acetate buffer in presence of calcium.

In the presence of RS20 (CaM:RS20:Ca²⁺ = 1:1.5:0.4) the most intense peak in the spectrum becomes the complex CaM-RS20-Ca₄ in the 8⁺ charge state (*Hill et al. 2000*). There are strong peaks due to the calmodulin-RS20 complex as well, but there is no evidence of complexes CaM-Ca with no peptide bound (fig13a).

The absence of calmodulin-RS20 complexes with two calciums bound and the dominance of the calmodulin-RS20-Ca₄ complex is consistent with the idea of two globular domains functioning cooperatively.

The ESI-FTICR mass spectra of calmodulin, RS20, and calcium in higher concentration (molar ratio 1:1.5:4) continues to show the complex calmodulin-RS20-Ca₄ as main peak, and no other peaks corresponding to complexes binding more than four calcium are present.

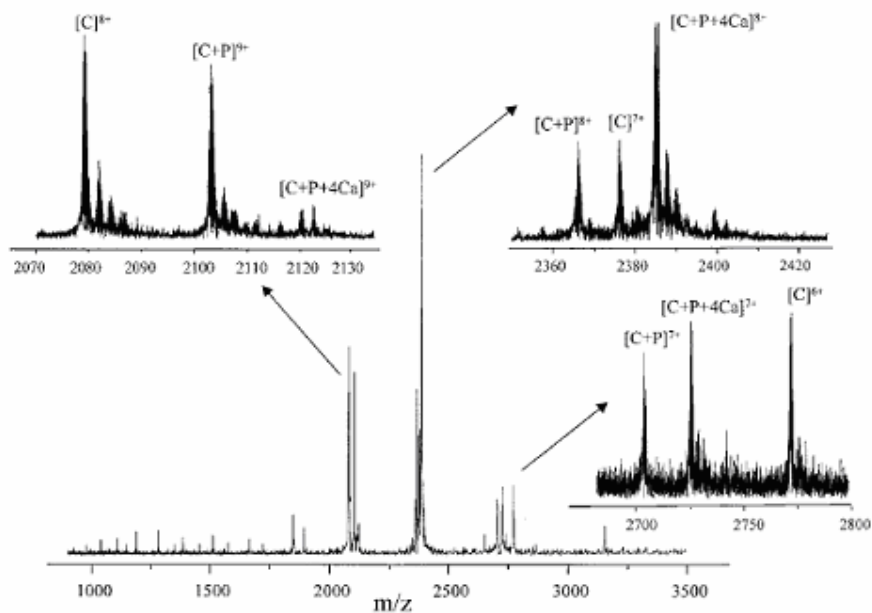

Fig 13a.: ESI-FTICR mass spectra of calmodulin in ammonium acetate buffer in presence of calcium and RS20.

Experimental procedures

Protein Synthesis and Purification. DNA-encoded calmodulin was obtained as previously described and purified by column chromatography (Craig *et al.* 1987 and Roberts *et al.* 1985). The purity of the protein was checked by SDS PAGE and high-pressure capillary electrophoresis, and it was found to be approximately 99% pure. Ultrapure water (Elga system) and plastic ware which had been washed in 1 N HCl were used to minimize metal cation and other contamination. Calmodulin (2.5 mg) was dissolved in 2.0 mL of ammonium acetate (5 mM, pH 5.9) and purified over a desalting PD 10 column (Pharmacia Uppsala) which had been previously equilibrated with ammonium acetate. The calmodulin concentration in the fraction used was determined by UV absorption on a Jasco V-550 spectrophotometer using a molar extinction coefficient for calmodulin of $\epsilon_{280 \text{ nm}} = 1560 \text{ M}^{-1} \text{ cm}^{-1}$ (Gilli *et al.* 1998).

Calmodulin-RS20 Sample Preparation. The RS20 peptide was synthesized and purified (greater than 99% pure) as described in literature (*Lukas et al. 1986* and *Guimard et al 1994*). A stock solution of the peptide was prepared by dissolving a 1.3-mg sample of lyophilized peptide in 565 μL of ammonium acetate (5 mM, pH 5.9) giving a concentration of 1.0 mM. Small aliquots of peptide stock were added to calmodulin solutions to achieve desired calmodulin to RS20 molar ratios. The calmodulin concentration was typically 25 μM (0.4 mg/mL), and peptide concentrations were varied from approximately 40 μM to several hundred micromoles. Where necessary, small aliquots (10 μL) of a concentrated CaCl_2 (Aldrich) stock were added to calmodulin-peptide solutions to give the required CaCl_2 concentrations. The use of physiologically relevant conditions is recognized to be important for maintaining the integrity of noncovalent complexes.

Electrospray Ionization-Fourier Transform Ion Cyclotron Resonance Mass Spectrometry. Mass spectrometry measurements were made using an FTICR mass spectrometer (Bruker Daltonics, Billerica, MA) equipped with a passively shielded 9.4 T superconducting magnet (Magnex Scientific Ltd., Abingdon, UK), a cylindrical infinity ICR cell with 0.06-m diameter, and an external ESI source (Analytica of Branford, Branford, CT). This FTICR instrument has been described in literature (*Lavanant et al. 1998* and *Palmblad et al 2000*).

The ESI source was equipped with a Pyrex capillary which was coated on both ends with platinum paint. The voltages on the nozzle and the skimmer were kept appropriately low (typically 60 and 3 V, respectively). Carbon dioxide was used as the drying gas in the electrospray source, and its temperature was carefully controlled. The background pressure in the ICR analyzer cell was typically below 2×10^{-10} mbar.

References

- Barrow M.P., Burkitt W., Derrick P.J., Principles of Fourier transform ion cyclotron resonance mass spectrometry and its application in structural biology, article sent for publication.
- Chin D., Means A.R., *Trends in Cell Biology*, 10 , 322-328, **2000**.
- Craig, T. A., Watterson, D. M., Prendergast, F. G., Haiech, J., and Roberts, D. M., *J. Biol. Chem.* 262, 3278-3284, **1987**.
- Feng R., Konishi Y., *J. Am. Mass Spectrometry*, 4, 638-645, **1993**.
- Ganem B., Li Y.T., Henion J.D., *J. Am. Chem. Soc.*, 113, 6294-6300, **1991**.
- Gaskell S.J., Electrospray: principle and practise, *Journal of Mass Spectrometry*, 32, 677-688, **1997**.
- Gilli, R., Lafitte, D., Lopez, C., Kilhoffer, M., Makarov, A., Briand, C., and Haiech, J. *Biochemistry* 37, 5450- 5456, **1998**.
- Guimard, L., Afshar, M., Haiech, J., and Calas, B. *Anal. Biochem.* 221, 118-126, **1994**.
- Hamdan M., Curcuruto O., *Rapid. Commun. Mass Spectrom*, 8, 144-148, **1994**.
- Hill T.H, Lafitte D., Wallace J.I, Cooper H.J., Tsevektov P.O., Derrick P.J., *Biochemistry*, 39, 7284-7290, **2000**.
- Jurasheck R., Dulcks T., Karas M., Nanoelectrospray-more than just a minimized-flow electrospray ionisation source, *J. Am. Soc. Mass Spectrom.*, **1998**.
- Katta V. and Chait B.T., *Rapid. Commun. Mass Spectrom.*, 5, 214-217, **1991**.
- Lavanant, H., Heck, A. J. R., Derrick, P. J., Mellon, F. A., Parr, A., Giffard, C. J., Horn, N., Gosson M. *J. Eur. Mass Spectrom.* 4, 405-416, **1998**.
- Loo J, Orgzalek-Loo R., *Rapid. Commun. Mass Spectrom*, 5, 102-105, **1991**.
- Lukas, T. J., Burgess, W. H., Prendergast, F. G., Lau, W., and Watterson, D. M. *Biochemistry*, 25, 1468-1464, **1986**.

- Palmblad, M., Håkansson, K., Håkansson, P., Feng, X., Cooper, H. J., Giannakopoulos, A. E., and Derrick, P. J. *Eur. J. Mass Spectrom.* **6**, **2000**, (in press).
- Roberts, D. M., Crea, R., Malecha, M., Alvarado-Urbina, G., Chiarello, R. H., and Watterson, D. M. *Biochemistry* , **24**, 5090-5098, **1985**.
- Wagner D.S., Anderegg R.J., *Anal.Chem.*, **66**, 706-710, **1994**.
- Wintrode P.L., Privalov P.L., *J.Mol.Bio.*, **266**, 1050-1062, **1997**.