

Liquid Level Sensor for High Temperature Molten Salt in Confined Container

Mohammad R. Allazadeh ^{* 1}, Roy D. Marangoni ², Mike R. Lovell ³

¹ Hungarian Academy of Sciences Konkoly-Thege út 29-33 1121 mta-ttk-mfa, Budapest, Hungary, allazadeh@mfa.kfki.hu

² University of Pittsburgh, 632 Benedum Hall, Pittsburgh, PA 15261, USA maran@engr.pitt.edu

³ University of Wisconsin-Milwaukee, P.O. Box 784, Milwaukee, WI 5320, USA, mlovell@uwm.edu

Abstract

Electrical resistance measurements on different rod materials in liquid solutions, molten salts, or molten lead are considered to design a liquid level sensor in a sealed containers when the temperature of the fluid is very high (~1000°C) and conventional measurements are not possible due to properties of the fluid or condition of the container. An analytical solution to the problem is adopted to reduce the cost of the sensor and overcome the difficulties of calibration of sensors at high temperature for prediction of the level of liquid. An electrical circuit model is suggested for analytical solution to compute the resistivity versus height of the electrode rod submerged in the liquid in a narrow container. Good prediction of circuit model for experimental results is verified by comparison of analytical results of different combination of liquid solutions and rods' material with experimental graphs.

Keywords

Analytical Solution; Electrical Circuit Mode; Confined Container; High Temperature Liquid; Liquid Level Sensor.

Introduction

The requirement of measurement on liquid height level in a machine or instrument where direct visual measurement cannot be implemented is the motivation to design liquid level sensors (LLS) which are calibrated to show the height of the liquid in a container using variation in different physical, chemical, or mechanical properties or liquid response to an external source as a function of height of liquid in the container. Most practical method of LLS devices is to measure the response of the liquid to an external source of energy. The external energy can be chosen to produce sound in ultrasonic sensors or light in optical sensors or different electrical quantities such as capacitance resistance or inductance in electrical sensors.

Top source device ultrasonic sensors employ the reflection of the waves from the level of the liquid to

determine the height of the liquid in the container. In case of bottom source sensors ultrasonic sensors, the time required to reach the waves to receiver through liquid is the factor to calibrate the sensor.

Principal of optical sensors is reflection of light from surface of the liquid or total internal reflection (TIR). In latter case, fiber optical fluid sensor is needed in which the optical fibers are embedded in easily cleaned surface for routine maintenance. Fresnel's equations are fundamental tools of measuring distance in fiber optic fluid level. The light source can be normal light, or for special application, laser or infrared light. In case of requirement of totally confined liquid container with small dimension at high temperature, both ultrasonic and TIR methods are not applicable. It is due to the size or structure of the sensor and uncertainty in controlling the information captured by the receiver.

Another option could be by means of measuring the pressure above the liquid using another liquid with different density. This requires contacting two liquids with each other, for which it is not possible in many cases because of harmful reaction between two liquids. Chemical activity of liquid or its components in service conditions, discards the applicability of sensors using pressure difference above some liquid in confined container.

Electrical sensors are sensors determining the level of the liquid using information collected in response of applied voltage to the liquid. They have the advantage of easy connection to control devices and software such as LabView. In most general and simple circuit, the measurable quantity is capacitance of a capacitor, resistance of a resistor, inductance due to electromagnetic field or impedance where a combination of all or two of previous quantity is measurable. However, they may be actuated based on the conductivity or resistivity. Electrical conductivity is

a characteristic of all material that is the measure of how well the material accommodates the movement of electric charges. Resistivity, measured usually in Siemens, has inverse physical meaning of conductivity but like conductivity is temperature dependent. Most of the current liquid level sensors' technologies are not suitable to measure the level of all types of liquids at high temperature due to the liquid container size, required sensitivity and operation temperature of the liquid.

Focus of this paper is on seeking and suggesting a technology which can be used for LLS at very high temperature, up to 2000 Fahrenheit (above 1000°C) degree. Such LLS has many industrial applications, particularly in mobile, and compact nuclear power plant such as those used in navy, for which the chemical activity of the fluid prevents using pressure difference sensors. The target of the current experiment is to find a suitable and easy method to measure the level of hot liquid confined in a container with the width less than 0.625 inch. The objective fluid melts FLiNaK (0.465 LiF, 0.115 NaF, and 0.42 KF) which cannot be exposed to air and moisture, and therefore, the completion of confinement of the container is an essential requirement. Hence, FLiNaK fluid must be filled in a refractory metal sealed container for the industrial application, which narrows the possible options among described sensors to determine the height of the liquid in its container. Seeking for simple method and the cost effect in the problem as well as possible parasite sound wave signals in case of reflecting sound from the surface of the liquid for ultrasonic sensors and shallow container for optical sensors working with surface or internal reflection principal, make the electrical sensor easy, cheap, and practical. This paper introduces an electrical circuit model for analytical solution to compute the electrical resistance versus height of the electrode rod submerged in the liquid confined in a narrow container.

Experiments' Description and Results

Numbers of experiment sets have been carried out with different combination of rods' material and solutions. Rods were mounted with specific distance apart from each other on top of a test-2 container and a voltage was maintained between them. Certain portion of liquid solution was added to the container at predefined elapsed time. Electrical resistance between two rods was measured using digital LCR. Figure 1

gives a general view of these experiments. The test-2 container was out of plastic with 500 ml scale. LCR device used in this experiment is HIOKI brand model 3511-50 LCR HiTE with high-speed measurement and high precision accuracy, as high as ±0.08 percentage. The LCR meter was connected to the rods with 9140 four terminal probe. The LCR meter set up is listed in table 1. The distance between rods was kept constant along the rods via two or three spacers to keep the rods paralleling as well. Rods were fixed with respect to the container to avoid their movement during experiment and keep them straight in vertical direction. The LCR meter was connected to the rods with two terminal probes. This can be seen in Figure 2.

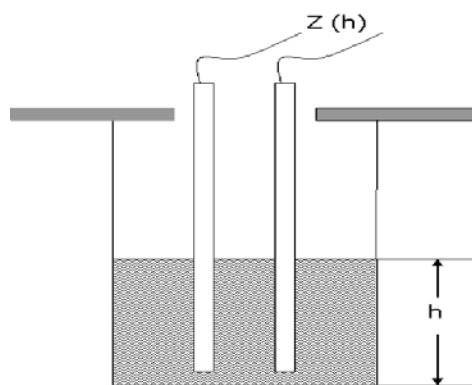

FIG. 1 GENERAL SCHEMATIC OF THE EXPERIMENT

TABLE 1 LCR SET UP FOR THE EXPERIMENT

Frequency [KHz]	1	Rang	Auto
Level [mV]	50	Open	Off
Speed	Slow	Short	Off
Circuit	Auto/ser	Trig	Internal circuit



FIG 2 CONNECTION OF PROBES TO THE RODS

The position of probes on the rod was examined to be inefficient in the outcome of the experiment by connecting them at different height of the rods. A funnel attached to a plastic pipe, was used to pour a new portion of liquid into container to avoid wetting of the rods during test for precise measurement. To

ensure the homogeneity of the solution, it was stirred for 30 minutes and left over night but stirred another 10 minutes before starting the experiment. It was observed that the electrical resistance value for the last digit of precision was time dependent as it was decreasing by time. Therefore, its value was recorded 20 second after increasing the height of the liquid.

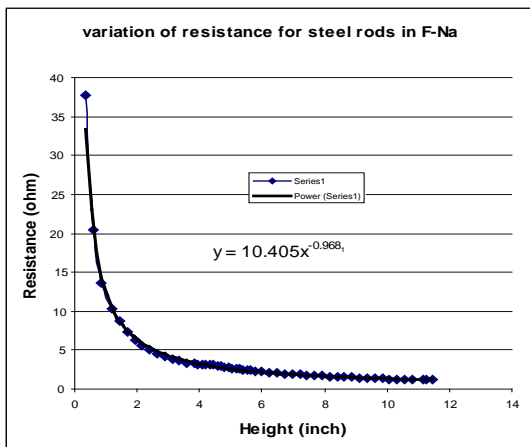

FIG 3 RESISTANCE BETWEEN STEEL RODS IN F-NA WATER SOLUTION VERSUS LIQUID LEVEL

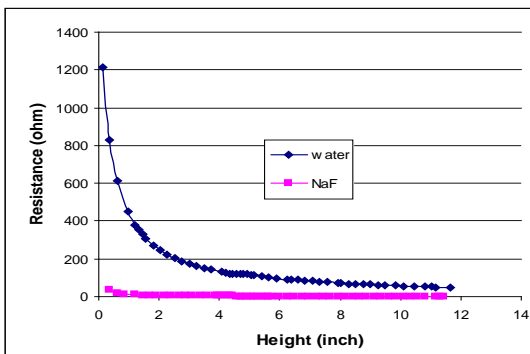

FIG 4 COMPARISON BETWEEN WATER AND NAF RESISTIVELY HEIGHT RELATIONSHIP

Change in resistivity between rods versus the portion of its length under level of liquid was recorded during experiment. These data were summarized in a table presenting the resistance versus height of the rods submerged in the liquid. The influence of different factors on resistance measured between two rods was investigated in each experimental set. The factors under investigations are the diameter of the rods, the space between rods, the type of the solution, the material of the container, and the material of the rods.

Experiment Set 1: Liquid Solution

The conductivity of the salt solution is a function of temperature. To check the effect of conductivity of solution in the shape of the height versus resistance

graph, this experiment set was carried out with sodium florid solution in water with concentration (c) of 0.2741 mol dm³ at room temperature.

The electrical conductivity of solution of NaF in water with this concentration was 2.1105 S/m at room temperature (T=298.15 K). The required mass of NaF in gram per liter of solution has been given by cFW, where FW was the formula weight and it was 41.99 g/gmol for NaF. The result was compared with the same experiment using tap water without NaF salt as liquid between rods. Rods were made of carbide steel with diameter 0.14 inch. For both sets of experiments, the rods were examined to be free from rust, which might affect the results. Figure 3 is the resistance recorded for steel rods submerged in Na-F water solution with the mentioned concentration. Figure 4 shows the comparison between results obtained from NaF solution and water tab. It can be deduced from Figure 4 that resistance for the NaF solution is considerably lower compared to the one without salt solution. This can be explained by high electro negativity of the ions of the NaF salt utilizing current between two rods compared to polar character of the water molecule.

Experiment Set 2: Container's Material

The aim of this set of experiment is to reveal the effect of the container on the height-resistance graph. To carry out this experiment, a steel tube was glued precisely in the test-2 container used in the experiment set 1. Then, the rods were fixed with glue in this cylinder as they were hung and glued to the tube by a piece of wood. This experimental set up is shown in the Figure 5. Liquid solution was NaF with the same concentration as used in experiment set 1. Figure 6 compares the results of the experimental set 2 with the experiment without the metal shell in plastic test-2 containers. The graphs in Figure 6 show that the results for both plastic and metal container overlap each other. Thus, the material of container play little or no noticeable role in the results.

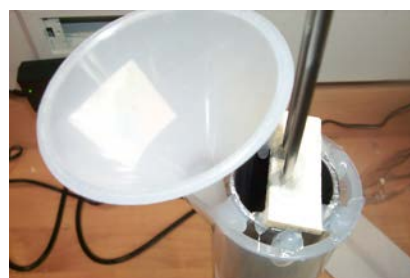



FIG. 5 EXPERIMENT STRUCTURE FOR CHECKING METAL CONTAINER EFFECT

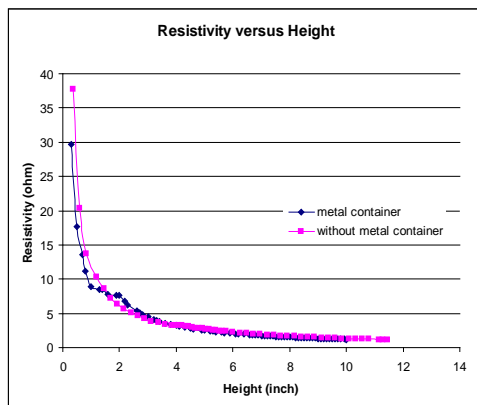

FIG. 6 COMPARISON OF EXPERIMENT SET 2 AND 3 TO INVESTIGATE THE EFFECT OF THE METAL CONTAINER ON THE RESULTS

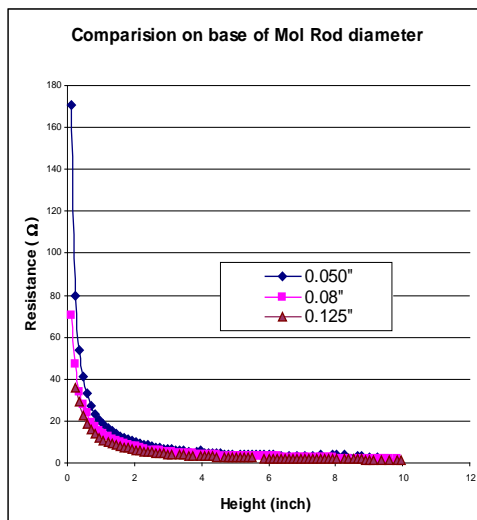

FIG. 7 COMPARISON OF RESISTANCE VERSUS HEIGHT OF MOLYBDENUM RODS WITH DIFFERENT DIAMETER SUBMERGED IN THE NaF SOLUTION

Experiment Set 3: Rods' Diameter

In these experiments set, the effect of the rods' diameter on the results is examined by the utilization of NaF solution electrolyte and pair Molybdenum rods as electrode with three different diameters. The rods were about 3 feet length with 0.050, 0.080 and 0.125 inches diameter. Recording data was started at the next level of height: 0.1 inch for rods with 0.05 and 0.08, and 0.2 inch diameter for 0.125 inch diameter. The section

in the graphs with slop adequately larger than zero is considered to find a one to one corresponding value between resistivity and height of the rods under liquid level. This section can be labeled as *calibration zone* of the graph. It can be concluded from Figure 7 that as the diameter of the rods decreases, the calibration zone of the graph becomes wide significantly.

Experiment Test 4: Rod Separation Distance

With the same experimental conditions as experimental set-3 but with different gap between the rods, Molybdenum rods with diameter 0.5 inch and 3 feet length has been tested to investigate whether the space between two rods affects the resistance measured between two rods. Figure 8 is the graphs for the results of the experiment with 0.25, 0.5, 1 and 1.5 inches space between the rods for 120Hz frequency.

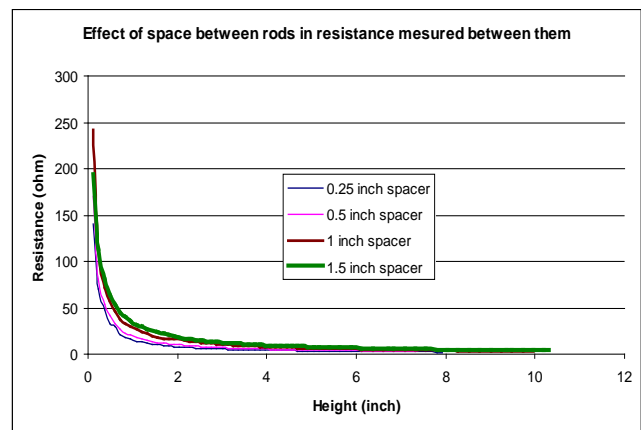

FIG. 8 EFFECT OF SPACE ON RESISTANCE MEASURED BETWEEN TWO RODS

It can be observed that the resistance gets larger for higher rods' space. This can be explained by increasing the amount of the liquid between the rods in which the passing path for the current is increased in the liquid. This increment of the path has resistivity which is a function of resistant of amount of liquid between the rods. Furthermore, Figure 8 shows that the electrical resistivity elevation is minor and belongs only to calibration zone below 6 inch of the liquid level.

Experiment Set 5: Rods' Material

Rods' resistivity plays a major role in the resistance measured between two rods. This experiments set conducts the effect of rods' material on electrical resistance between rods out of different materials submerged in the same liquid solution and compares them using the graph of their submerged rods' height versus resistance of the model.

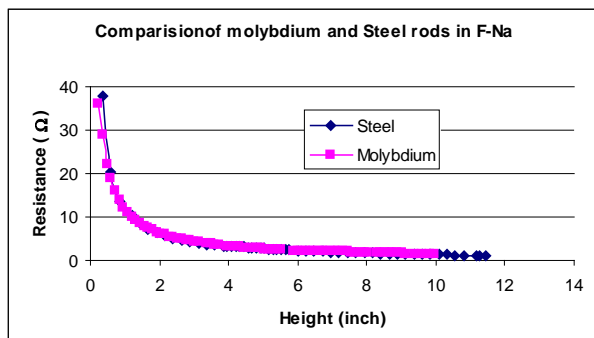

FIG. 9 SUBMERGED LENGTH OF THE MOLYBDENUM RODS AND STEEL RODS IN F -NA WATER SOLUTION

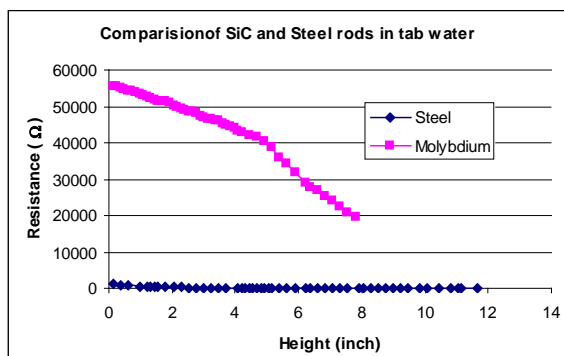

FIG. 10 COMPARISON BETWEEN RESISTANCE OF SiC RODS AND STEEL IN TAB WATER

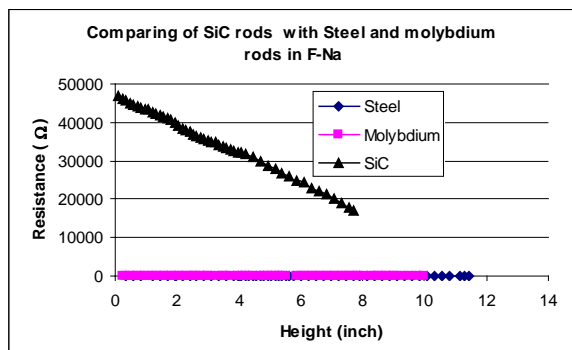

FIG. 11 HIGH RESISTANCE OF SiC RODS IN F-NA WATER SOLUTION COMPARE TO RESISTANCE MEASURED ON STEEL AND MOLYBDENUM RODS

Figure 9 presents the comparison between steel rods with diameter 0.14 inch and molybdenum with 0.125 inch both in fluoride sodium. Despite their insignificant difference in diameter, they behave similarly in F-Na liquid solution, and employ 50 mV voltages between rods. It might be of the cause that the conductivity of steel 310 is 1.3×10^4 S and for the molybdenum one is 19×10^4 S. The effect of the rod conductivity is more obvious if metal rods (which have much higher conductivity) is compared to semiconductors such as silicon carbide. Figure 10 demonstrates this comparison between SiC and steel

rods in water, while Figure 11 is the comparison among 0.25-inch diameter SiC rods with 0.14-inch diameter steel and 0.125-inch diameter molybdenum rods in F-Na water solution. It can be found from the graphs in Figure 12 that the resistivity is high between less conductive SiC rods for all range of the liquid level compared to good conductive metal rods.

Discussion

Thermal characteristic of materials at high temperature is not well enough known, therefore, all of these data have to be provided by extrapolation. Non-linear behavior of these characteristic make these extrapolations somewhat unreliable. Conductivity and resistivity of material are of the material characteristics, in which temperature dependent and consequently are affected by thermal characteristics behavior at high temperature. Conductivity of material has been established for many elements and engineering materials and it is well known that the conductivity of material decreases as temperature increases, or in some other material this reveals by increasing resistivity at higher temperature. Increasing in imperfection in the atomic lattice structure hampers electron movement. Moreover, thermal energy causes vibration of atoms about their equilibrium position and this interferes with electron movement. Therefore, having a model which can be used to ease the calibration of liquid level sensor reduces the difficulty of calibration of the sensor (e.g. safety issues, cost effect, required equipments, time, etc) at high temperature. Summarizing the results from experimental sets helps the establishment of an appropriate analytical model.

Following comments can be listed in the summary of experimental set results about the resistance measured between two rods subjected to DC voltage difference at room temperature,

Increasing the height of the rods under level of liquid decreases the resistance both in water and F-Na in water solution, which can be seen in Figures 3 and 4. It is due to higher conductivity of liquid in comparison to air which is practically an insulator. Hence, as larger portion of the gap between rods which are filled with liquid, the movement of electron from positive electrode to negative becomes easier. Here, the conventional sign is considered for the direction of electron movement.

Effect of liquid conductivity on the resistance is obvious in Figure 4.

The comparison of graphs in Figure 6 shows that only the gap between two rods affects the electrical resistance and the container space has insignificant effect on the measured resistance.

Rod’s diameter has inverse relationship with resistance in calibration zone. Graphs for different molybdenum rods with different diameter in Figure 7 show that thicker rods have less resistance for the same experimental condition.

Space between rods has direct relationship with the resistance, which is confirmed by means of graphs in Figure 8.

For the same liquid, shape of the graph depends on conductivity of the rods. This fact is concluded from Figures 9, 10, and 11.

The effective of factors on the measured resistance in the aforementioned summary suggests that the resistance base technology in liquid level sensors can be modeled with an electrical circuit, which is described in the next section.

Analytical Model: Electrical Circuit Model

Replacing all components of the experiment with elementary elements in the electrical circuit can give a potential model for analytical computation of the experiment. The model should have all characteristics of the experiments and it must be verified by confirming the results of the experimental sets. Thenceforth, it can be concluded that the model is appropriate for whole temperature range. Both sections of rods under and above the liquid level have the same resistivity, however, their participations in the resistance against the electric current is different, and therefore, each section’s effect is assigned with different resistance. Liquid solution behaves like an electrolyte and passes electrons according to its own conductivity. Thus, in the model another resistance is considered for the resistivity of electrolyte.

Figure 12 shows the sketch of this model. R2 and R3 are equivalent resistant of rods connected to positive and negative voltage. Resistance of high temperature liquid is represented with R1. Here two small resistors (R4, R5) are representative of the resistance of the rods length under the liquid level. These resistances have series connection and consequently the total resistance of the circuit (R) is the summation of them.

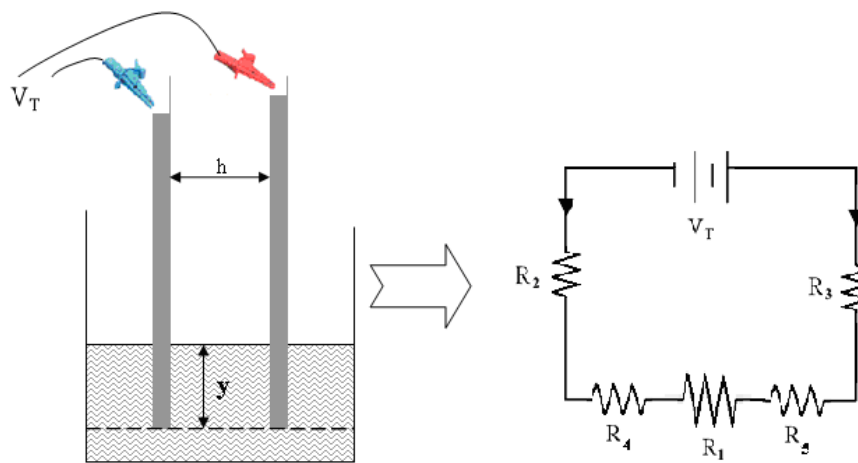

FIG. 12 CORRESPONDING ELEMENTS IN CIRCUIT MODEL FOR THE RESISTANCE BASE HIGH TEMPERATURE LIQUID LEVEL SENSOR

Then, the resistance of material for rods and liquid can be obtained by using the material resistivity as next,

$$R_1 = \frac{\rho_{liquid} L_{Liquid}}{A_L} \tag{Eq-1}$$

$$R_2 = R_3 = \frac{\rho_{rod} (L_{rod} - y)}{A_{rod}} \tag{Eq-2}$$

Where y is the height of the rod submerged in the liquid. The resistivity of liquid is ρ_{liquid} and its value for

our application is equal to the electrical conductivity of the FLiNaK. ρ_{rod} is the electrical resistivity of the rod used in the experiment. L_{liquid} is the length of resistance considered for R1 and it is equal to the resistance of liquid between two rods (h in Figure 12). The cross-section area of the rod is $A_{rod} = \pi d_{rod}^2 / 4$. A_L is the area in liquid between two rods which approximates the effective electrical resistance in the total resistance. In a two dimensional model, A_L is the

product of diameter of rod and length of rod submerged in the liquid. Then the resistance of the circuit is computed by the following equation,

$$R = \frac{8 \rho_{rod} (L_{rod} - y)}{\pi d_{rod}^2} + \frac{\rho_{Liquid} h}{y d_{rod}} + \frac{2\rho_{rod}}{y} \quad (Eq-3)$$

The last term stands for the portion of the two rods in the liquid which are expressed as resistances R4 and R5 in the model of Figure 13. Factor 2 indicates that both resistors are considered in the model, in which the analytical results for calibration are suggested by Eq-3. For y=0 in Eq-3 the resistivity is infinite since rods behave like capacitor and the model is an open circuit. In case of y=L the effects of rods material and length are given only by the second and the third terms. Verification is done taking into account each factor of Eq-3 in comparison to the experimental results with analytical results computed based on the suggested circuit model.

For functional verification of the circuit model, analytical results of liquid and rods used for experiment sets are obtained with the same rod's diameter, gap between rods, and liquid level. Table 2 lists the conductivity and resistivity of the material and solutions used for rod as electrode and liquid as electrolyte in analytical results computation for the verification.

Verification of Analytical Results

Verifications for the diameter of rod are investigated in Figures 13, 14 and 15. Figure 16, 17, and 18 verify that the model can predict the same results as experimental results for different rods' diameter. Figure 19 confirms that the model predicts correctly the same graph for rods other than molybdenum.

It can be seen that regardless of the material of the rods the effect of the resistivity of the rods is taken correctly in the model.

The effect of the type of the liquid through its resistivity in the results is checked by taking into consideration the steel's rods in Figure 20 in which the suggested circuit can be an appropriate model to get the results analytically. In all verifications, analytical results obtained by circuit model, are normalized with a calibration constant to show good correlation between experimental and analytical results but even without this calibration factor, the same prediction on the graph shape was observed. Relationship between the

resistance and liquid level for SiC in water and Fluoride sodium water solution is linear as it can be seen for both analytical and experimental results in Figures 21 and 22 both showing that the circuit model can predict the shape of the graph correctly. The vertical shift of analytical results compared to experimental one can be corrected by a second calibration factor by means of the difference between their trend lines.

TABLE 2: CONDUCTIVITY AND RESISTIVITY OF MATERIALS USED FOR ANALYTICAL CALCULATION

Material	Property	
	Conductivity S/Cm	Resistivity (Ω · Cm)
FLiNaK	2.187	0.457
F-Na	0.0211	47.382
Tab water (Pittsburgh area)	0.001	1000
Steel 310	13888.889	0.000072
Silicon carbide	0.01	100
Silicon nitride	5 e-14	2 e13
Molybdenum	192307.69	0.0000052

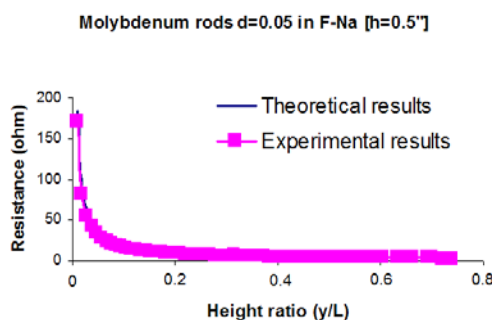

FIG. 13 COMPARISON BETWEEN EXPERIMENTAL RESULTS AND ANALYTICAL RESULTS OBTAINED FROM CIRCUIT MODEL NORMALIZED FOR MOLYBDENUM RODS OF DIAMETER D=0.05 INCH AND ROD SEPARATION DISTANCE H=0.5 INCH NAF.

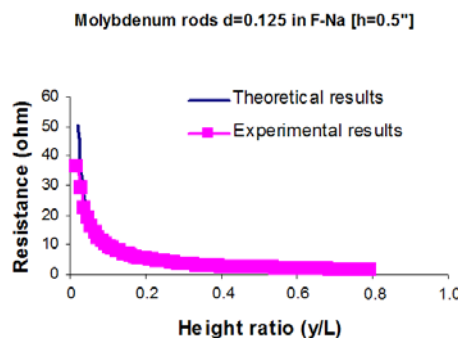

FIG. 14 COMPARISON BETWEEN EXPERIMENTAL RESULTS AND ANALYTICAL RESULTS OBTAINED FROM CIRCUIT MODEL NORMALIZED FOR MOLYBDENUM RODS OF DIAMETER D=0.125 INCH AND RODS' SEPARATION DISTANCE H=0.5 INCH NAF.

Molybdenum rods $d=0.05$ in F-Na [$h=1'$]

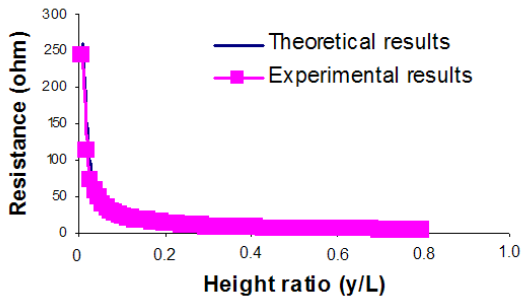

FIG. 15 COMPARISON BETWEEN EXPERIMENTAL RESULTS AND ANALYTICAL RESULTS OBTAINED FROM CIRCUIT MODEL NORMALIZED FOR MOLYBDENUM RODS OF DIAMETER $D=0.05$ INCH AND RODS' SEPARATION DISTANCE $H=1$ INCH IN F-NA.

Molybdenum rods $d=0.05$ in F-Na [$h=1.5'$]

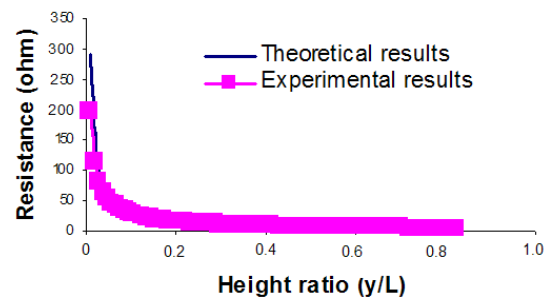

FIG. 18 COMPARISON BETWEEN EXPERIMENTAL RESULTS AND ANALYTICAL RESULTS OBTAINED FROM CIRCUIT MODEL NORMALIZED FOR MOLYBDENUM RODS OF DIAMETER $D=0.05$ INCH AND RODS' SEPARATION DISTANCE $H=1.5$ INCH F-NA.

Molybdenum rods $d=0.08$ in F-Na [$h=0.5'$]

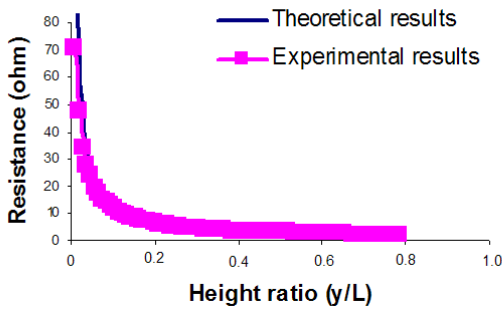

FIG. 16 COMPARISON BETWEEN EXPERIMENTAL RESULTS AND ANALYTICAL RESULTS OBTAINED FROM CIRCUIT MODEL NORMALIZED FOR MOLYBDENUM RODS OF DIAMETER $D=0.08$ INCH AND RODS' SEPARATION DISTANCE $H=0.5$ INCH F-NA.

Steel rods $d=0.14$ in Water [$h=0.5'$]

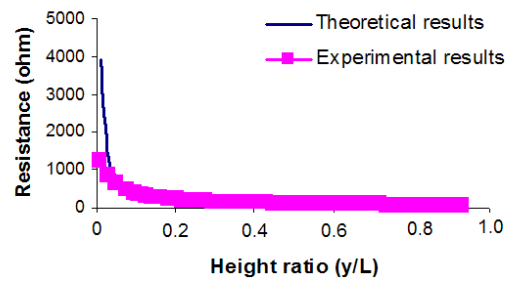

FIG. 19:COMPARISON BETWEEN EXPERIMENTAL RESULTS AND ANALYTICAL RESULTS OBTAINED FROM CIRCUIT MODEL NORMALIZED FOR STEEL RODS OF DIAMETER $D=0.14$ INCH AND RODS' SEPARATION DISTANCE $H=0.5$ INCH IN WATER.

Molybdenum rods $d=0.05$ in F-Na [$h=0.25'$]

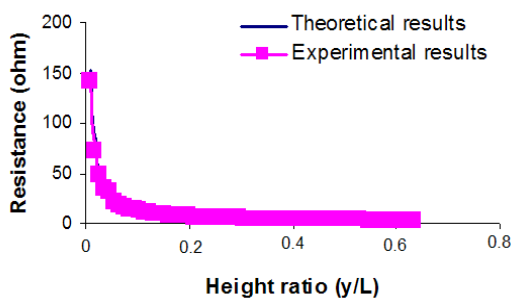

FIG. 17 COMPARISON BETWEEN EXPERIMENTAL RESULTS AND ANALYTICAL RESULTS OBTAINED FROM CIRCUIT MODEL NORMALIZED FOR MOLYBDENUM RODS OF DIAMETER $D=0.05$ INCH AND RODS' SEPARATION DISTANCE $H=0.25$ INCH F-NA.

SiC rods $d=0.25$ in Water [$h=0.5'$]

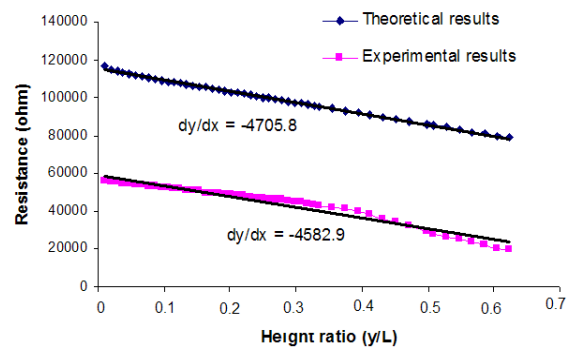

FIG. 20 COMPARISON BETWEEN EXPERIMENTAL RESULTS AND ANALYTICAL RESULTS OBTAINED FROM CIRCUIT MODEL FOR SiC RODS OF DIAMETER $D=0.25$ INCH AND RODS' SEPARATION DISTANCE $H=0.5$ INCH WATER.

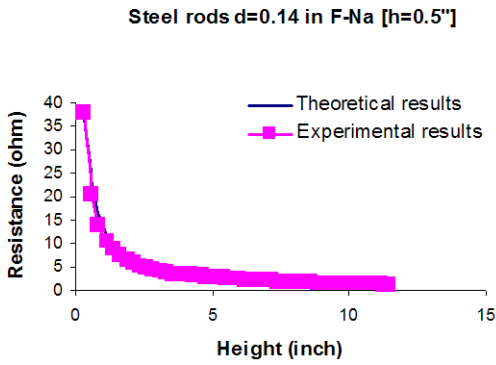

FIG. 21 COMPARISON BETWEEN EXPERIMENTAL RESULTS AND ANALYTICAL RESULTS OBTAINED FROM CIRCUIT MODEL NORMALIZED FOR STEEL RODS OF DIAMETER D=0.14 INCH AND RODS' SEPARATION DISTANCE H=0.5 INCH NAF.

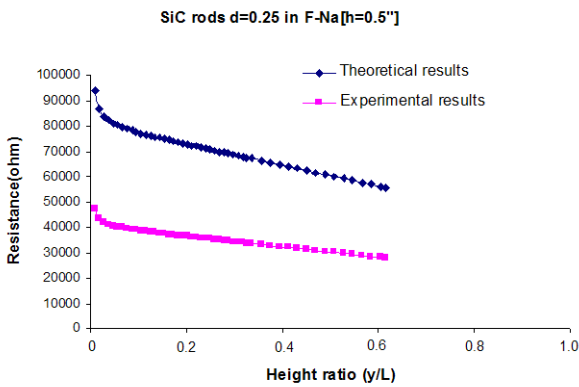

FIG. 22 COMPARISON BETWEEN EXPERIMENTAL RESULTS AND ANALYTICAL RESULTS OBTAINED FROM CIRCUIT MODEL FOR SiC RODS OF DIAMETER D=0.25 INCH AND RODS' SEPARATION DISTANCE H=0.5 INCH NAF.

Analytical Results

Figures 13 to 22 examine all the factors in the Eq-3 which are effective in the value measured experimentally for resistance between the rods corresponding to different liquid level. Consequently, resistance versus liquid level results can be predicted adequately well using circuit model and Eq-3 without the implementation of experiment for various arrangements in the experiment (e.g. different rods' material, or other liquid solution with known conductivity, different rods diameter, or space between rods). In this section, some of these results have been obtained and compared with each other. In computing the analytical resistance, data of table 2 was employed. Effect of material property of rods in the shape of graph for the resistance versus height is examined in Figures 23 and 24. Figure 23 shows high conductive metal rods like molybdenum and steel in liquid solution, in which

its conductivity is significantly less than rods like molten FLiNaK salt at high temperature. The results give an exponential graph with defined calibration zone in aforementioned case. The calibration zone and the value of resistance depend on the conductivity of the rods and its difference with the conductivity of the liquid. As the conductivity (or more precisely the difference between rods conductivity and liquid conductivity) increases, for example by using molybdenum rods instead of steel rods, the resistance rises and the graph shifts up. Figure 24 shows that in reverse case when the liquid has considerably less resistance, in comparison to the rods, i.e. for rods out of insulator materials such as silicon carbide and silicon nitride, then the graph is linear. This can be investigated by the experiment using liquid with different conductivity but the same rods combination. Figure 25 show this effect for F-Na and FLiNaK. Since the difference is insignificant and molybdenum is considered conductive for both liquid solutions, therefore, the difference in liquid conductivity brings the graph up and extends the calibration zone.

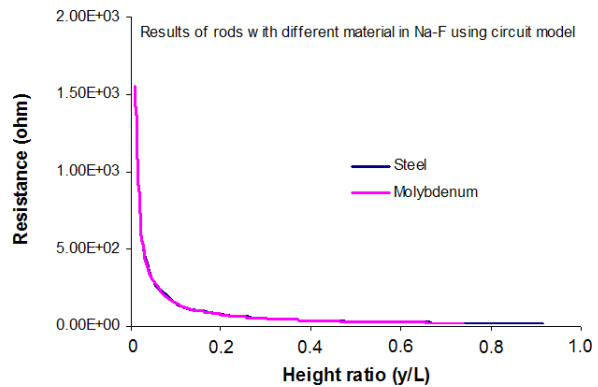

FIGURE 23: ANALYTICAL EXAMINATION OF THE EFFECT OF ROD MATERIAL ON RESISTANCE

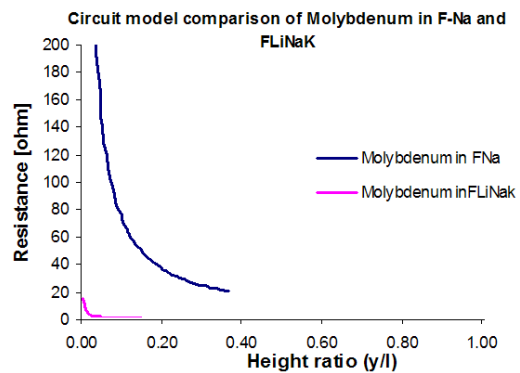

FIGURE 24: CAPARISON OF ANALYTICAL SOLUTION OF MOLYBDENUM RODS IN DIFFERENT LIQUID SOLUTION (NAF IN WATER, FLINAK)

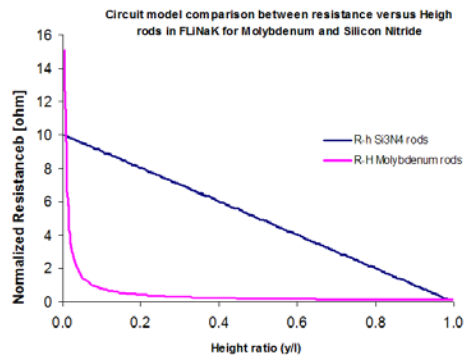

FIGURE 25 : COMPARISON OF ANALYTICAL SOLUTION OF RODS OF DIFFERENT MATERIAL (Si3N4, MOLYBDENUM) IN THE SAME LIQUID SOLUTION (FLiNaK)

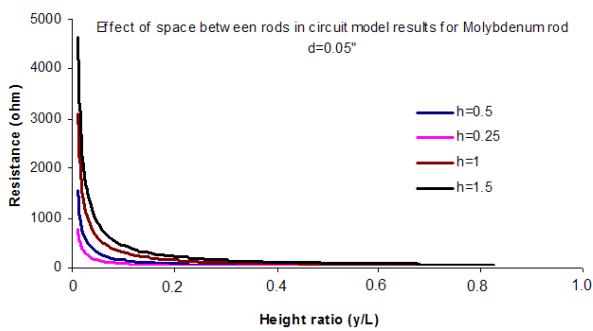

FIGURE 26: EXAMINING THE EFFECT OF SPACE BETWEEN RODS ON THE RESISTANCE ANALYTICALLY

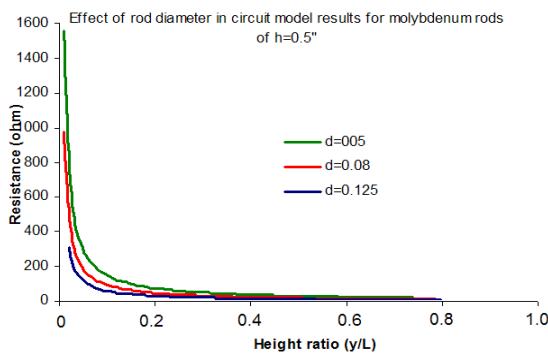

FIGURE 27: EXAMINING THE EFFECT OF RODS DIAMETER ON THE RESISTANCE ANALYTICALLY

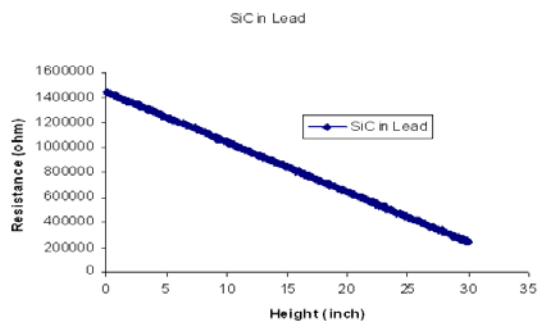

FIGURE 28: ANALYTICAL RESULTS FOR SILICON CARBIDE IN LEAD SOLUTION

Reinvestigation of effect of space between rods and rods' diameter analytically using the suggested circuit model, leads to the same conclusion as what was claimed experimentally. This conclusion can be obtained by comparisons made in Figures 26 and 27. Figure 28 shows the linear response of silicon carbide rods of 0.25-inch diameter with $h=1.0$ inch in a molten lead solution based the analytical model of Eq-3. Consequently, the model can be used in general sense for any experiment, rods of different material, and liquid solutions to produce various types of liquid level sensor for different purpose and applications.

Conclusions

Resistivity-based electrical sensor is an accurate and suitable choice in designing LLS at high temperature in closed loops or sealed containers especially when the fluid cannot be in contact with any other fluid or gas because of chemical reactivity, or when the conventional types of LLS fail to function due to circumstances of the container. Resistivity-based level sensor has simple design in which the fluid level is determined based on the measured resistance. An electrical circuit model has been suggested and verified for analytical computation. The experimental results have confirmed the validity of the analytical expression. Different factors affect the measured resistance and, therefore, these sensors need to be accurately calibrated. The experimental results and analytical outcomes approve the effect of these factors to be as following:

Space between the rods increases the measured resistance,

Rod's diameter has inverse relation with the resistance value,

Rod's electrical resistivity has direct relation with the recorded resistance,

Liquid's resistivity increases the electrical resistance of the sensor,

The liquid level is determined by height of rods submerged in the liquid. Resistance decrease with increasing liquid level,

Resistance versus liquid level graph depends on the differences between conductivity of rods compared to liquid. If the rods are categorized based on conductive, the graph is exponential and if it is labeled as insulator, the graph is linear.

This method to design liquid level sensors and the

suggested analytical model could be deployed for wide range of industrial applications at high temperature.

REFERENCES

- Balbuena, Perla B., Conductivity and viscosity studies of ethylene carbonate based solution containing lithium perchlorate, Prabhu, P.V.S.S. (Central Electrical Carolina), Journal of the Electrochemical Society, v 146, n 10, Oct, 1999, p 3613-3622
- Boca Raton, CRS Handbook of Chemistry and Physics, 66th edition, CRC Press, Inc., Florida, pp. B-68-b-161 (1985)
- Chen, H.P., Fregus J.W., Jang, B.Z., Effect of Ethylene carbonate and salt concentration on the conductivity of propylene carbonate/lithium perchlorate electrolytes, Journal of the electrochemical Society, v 147, n 2, Feb, 200, p 339-406
- G. J. Janz, NIST Standard database 27, NIST Properties of molten Salts database, version 2.0 Molten salts Data center, Rensselaer Polytechnic Institute, Troy, NY, distributed by NIST, (1992).
- J. W. Snow, A fiber optic fluid level sensor:: Practical consideration SPIE Vol 945 optical testing and Metrology II (1988), 657-661
- J. Barthel, R Buchner, Chemistry Data Series, Vol. XII, part 2, Dielectric Properties of water and aqueous electrolyte solution, ISBN 3-926959-62-2, 1995
- J. Barthel, R. Buchner, M. Munsterer, Dielectric properties of water and aqueous electrolyte solution, Chemistry data series, Vol. XII part 2, ISBN 3-926959-62-2, 1995
- J. Barthel, R. Neueder, Conductivities, Transference Numbers, and Limiting Ionic conductivities of solution of Aprotic, Protophobic Solvents II: Carbonates, Electrolyte data collection, Chemistry data series, Vol. XII, Part 1d
- J. Barthel, R. Neueder, Conductivities, Transference Numbers, and Limiting Ionic conductivities of solution of Aprotic, Protophobic Solvents IV Ketones, Esters and Nitrohydrocarbons, Electrolyte data collection,
- Li, Tao, Balbuena, Perla B., Theoretical studies of lithium perchlorate in ethylene carbonate, propylene carbonate, and their mixtures, Journal of the Electrochemical society, v 146, n 10, Oct, 1999, p 3613-362