



UNIVERSITY
OF TRENTO

DIPARTIMENTO DI INGEGNERIA E SCIENZA DELL'INFORMAZIONE

38123 Povo – Trento (Italy), Via Sommarive 14
<http://www.disi.unitn.it>

EXPERIMENTAL VALIDATION OF
A FULLY-ADAPTIVE SMART ANTENNA PROTOTYPE

M. Benedetti, R. Azaro, and A. Massa

May 2008

Technical Report # DISI-11-046

Experimental validation of a fully-adaptive smart antenna prototype

M. Benedetti, R. Azaro, and A. Massa

In this letter, the architecture of a fully-adaptive smart antenna working in the 2.4 GHz band is described and its functionalities preliminary assessed. The radiating unity consists of a 8-elements linear array of dipoles with a finite reflecting plane. The adaptive behaviour is achieved by means of a set of electronically-driven vector modulators that realize the array weights. The capability to react in real-time to complex interference scenarios is provided by a SW control module based on the Particle Swarm Optimizer (PSO) algorithm. In order to assess the effectiveness of such an implementation, a selected set of results is reported and discussed.

Introduction: The growing diffusion of devices for mobile communications requires an efficient exploitation of wireless channels to achieve a suitable quality of service (QoS). In such a framework, smart antennas [1]-[3] seem to be promising tools to provide an efficient management of the physical layer. As a matter of fact, they are aimed at maximizing the system performance in terms of signal-to-interference-plus-noise ratio (SINR) at the output of the receiver. Although the effectiveness of adaptive arrays has been theoretically proven [4], the technological difficulties and costs arising in the implementation prevented their widespread application in wireless communications. Consequently, simpler architectures as reconfigurable [5][6] or switched-beam antennas [1][3] have been implemented. In this letter, an

implementation of a fully-adaptive antenna is described and validated dealing with a complex interference scenario.

Fully-adaptive antenna structure: Let us consider the fully-adaptive antenna shown in Fig. 1. The system architecture consists of (a) the radiating module, (b) the HW control module, (c) the combiner of the RF signals, and (d) the software control module. With reference to the picture in Fig. 1, the antenna is composed by a linear array of dipoles [7] ($d = \lambda_0/2$, λ_0 being the free-space wavelength) and a finite reflecting plane of extension $9\lambda_0 \times \lambda_0$ parallel to the array at a distance of $\lambda_0/4$. As far as the other modules are concerned, the array weights $\underline{w} = \{w_n; n = 1, \dots, 8\}$ have been implemented by means of vector modulators working at 2.4 GHz. They introduce an attenuation (-4.5 ÷ -34.5 dB) and a phase shift delay ($0^\circ \div 360^\circ$) determined by a couple of low frequency differential voltages (-500 ÷ 500 mV). The outputs of the control module are then grouped in a passive RF power combiner (8 way, 0°), built on an Arlon dielectric substrate. The combined signal is then processed by a spectrum analyzer that emulates a receiver able to estimate the SINR defined as [8]

$$\text{SINR}(\underline{w}) = \frac{P_d(\underline{w})}{P_n + P_i(\underline{w})} \quad [\text{dB}]$$

where P_d , P_i , and P_n are the power of the desired signal, the power of the interference and the background noise power, respectively. The whole system is controlled by a personal computer through the PSO-based software control. Starting from the measured SINR value and according to the PSO strategy

[9][10], the control looks for the optimal coefficients \underline{w}_{opt} that maximizes the SINR. As a consequence, the radiation pattern is modified to place a maximum value of attenuation in the DoA θ_i of the interference signal. As far as the HW interfaces are concerned, a GPIB interface has been adopted between the PC and the spectrum analyser. Moreover, a digital-to-analogue I/O interface has been used to drive the vector modulator. Finally, in order to avoid/minimize the electromagnetic interferences between the radiating elements and other HW components, the modules (a) and (b) have been placed just behind the rectangular reflecting surface.

Experimental results: In order to preliminary assess the adaptive behaviour of the smart antenna, a time-varying scenario characterized by a set of interfering signals impinging on the fully-adaptive array from different and variant DoAs has been considered. A set of $J=6$ different time steps $\{TS_j; j=1, \dots, J\}$ has been considered. At each time-step, the DoA of the interference $\theta_i^{(i)}$ has been changed to verify whether the system is able to iteratively control the angular position of the attenuation maxima of the radiation pattern and thus, automatically turning off the interferences. Towards this end, a maximum amount of $K = 400$ PSO iterations has been considered in correspondence with each time-step to determine \underline{w}_{opt} . Figure 2 shows the evolution of the measured SINR versus the iteration index k during the optimization process ($\Delta T_k = 0.3 \text{ sec}$). To prove the reliability of the HW implementation, the measured SINRs have been compared with the simulated values obtained by applying the control strategy proposed in [9] to the

scenario at hand. Despite some differences, mainly due to the inaccuracy of the simulations in modelling the real radiators, the mutual coupling effects, and the presence of the reflecting plane, an acceptable agreement can be observed.

In order to point out the rejection ability of the adaptive system, two representative beam patterns at TS_2 ($\theta_i^{(2)} = 106^\circ$) and TS_4 ($\theta_i^{(4)} = 80^\circ$) are shown in Fig. 3 and 4, respectively. As it can be noticed, the system prototype is able to place a minimum of the beam pattern towards the interference and to maintain the main beam oriented along the DoA of the desired signal ($\theta_d = 0^\circ$).

Conclusions: In this letter, the prototype of a fully-adaptive smart antenna has been described. A selected set of experimental results has been reported to assess the effectiveness of the proposed architecture in adaptively shaping the antenna beam pattern to maximize the reception performance of the system.

References

- 1 CHRYSSOMALLIS, M.: 'Smart Antennas', IEEE Antennas Propagat. Mag., 2000, 42, pp. 234-238
- 2 BELLOFIORE, S., BALANIS, C. A., FOUTZ, J., and SPANIAS, A. S.: 'Smart antenna systems for mobile communication networks. Part 1: overview and antenna design', IEEE Antennas Propagat. Mag., 2002, 44, pp. 145-154
- 3 BELLOFIORE, S., FOUTZ, J., BALANIS, C. A., and SPANIAS, A. S.: 'Smart antenna systems for mobile communication networks. Part 2: beamforming and network throughput', IEEE Antennas Propagat. Mag., 2002, 44, pp. 106-114
- 4 APPLEBAUM, S. P.: 'Adaptive arrays' IEEE Trans. Antennas Propagat., 1976, 24, pp. 585-598
- 5 MIGLIORE, M. D., PINCHERA, D., and SCHETTINO, F.: 'A simple and robust adaptive parasitic antenna', IEEE Trans. Antennas Propagat., 2005, 53, pp. 3262-3272
- 6 PETIT, L., DUSSOPT, L., and LAHEURTE, J. M.: 'MEMS-switched parasitic-antenna array for radiation pattern diversity', IEEE Trans. Antennas Propagat., 2006, 54, pp. 2624-2631
- 7 CHUANG, H. R. and KUO, L. C.: '3-D FDTD design analysis of a 2.4-GHz polarization-diversity printed dipole antenna with integrated balun and polarization-switching circuit for WLAN and wireless communication applications' IEEE Trans. Microwave Theory Techn., 2003, 51, (2), pp.374-381
- 8 WEILE, D. S. and MICHIELSEN, E.: 'The control of adaptive antenna using dominance and diploidy', IEEE Trans. Antennas Propagat., 2001, 49, pp. 1424-1433
- 9 BENEDETTI, M., AZARO, R., FRANCESCHINI, D., and MASSA, A.: 'PSO-based real-time control of planar uniform circular arrays', IEEE Antennas Wireless Propag. Lett., 2006, 5, pp. 545-548
- 10 ROBINSON, J. and RAHMAT-SAMII, Y.: 'Particle swarm optimization in electromagnetics', IEEE Trans. Antennas Propagat., 2004, 52, (2), pp. 397-407

Authors' affiliations:

M. Benedetti, R. Azaro, and A. Massa
ELEDIA Research Group
Department of Information and Communication Technology
University of Trento, Via Sommarive 14, 38050 Trento – ITALY

Corresponding Author:

A. Massa
ELEDIA Research Group
Department of Information and Communication Technology
University of Trento
Via Sommarive 14
38050 Trento
ITALY
E-mail: andrea.massa@ing.unitn.it

Figure captions:

Fig. 1 Fully-adaptive antenna architecture and photograph of the antenna prototype.

Fig. 2 Evolution of the SINR
——— simulated
----- measured

Fig. 3 Radiation pattern at TS_2 ($\theta_d = 0^\circ$ and $\theta_i^{(2)} = 106^\circ$)
——— simulated
----- measured

Fig. 4 Radiation pattern at TS_4 ($\theta_d = 0^\circ$ and $\theta_i^{(4)} = 80^\circ$)
——— simulated
----- measured

Figure 1

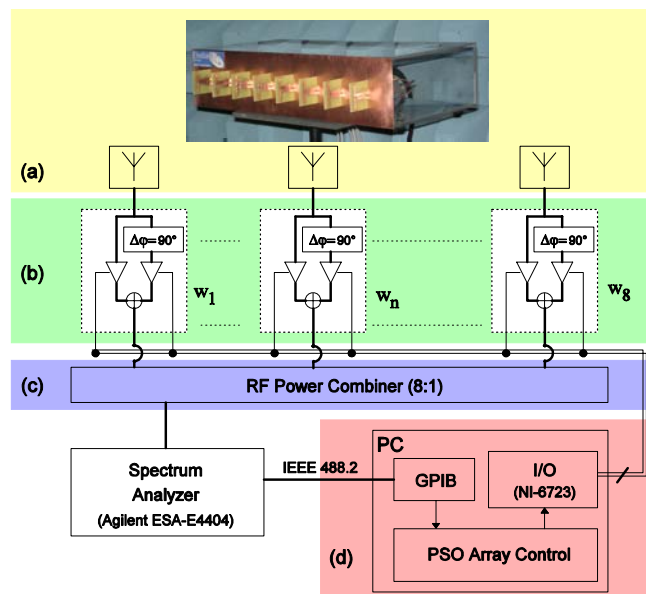

Figure 2

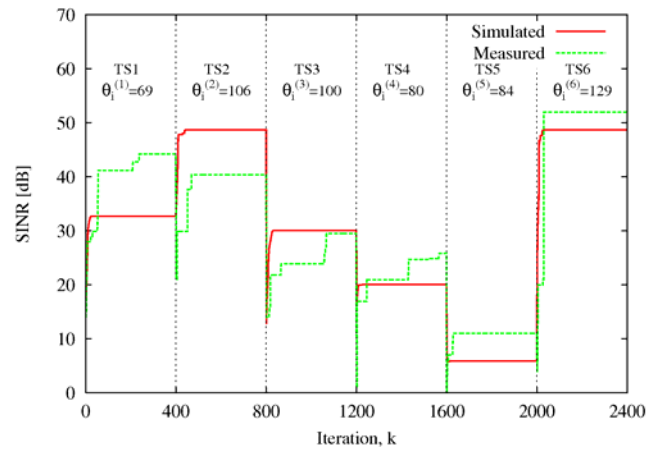

Figure 3

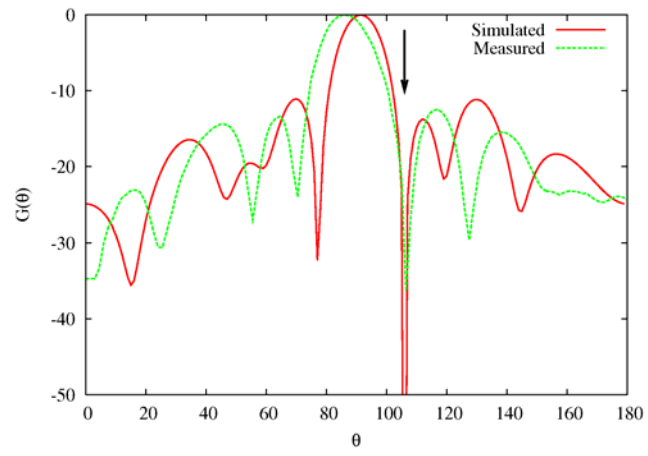

Figure 4

