

7

DESIGN FOR TESTABILITY II: FROM HIGH LEVEL PERSPECTIVE

Chia Yee Ooi
Norlina Paraman

7.1 CONTEXT

The advantage of a top-down design flow, specifying design a high abstraction level with less implementation specific details, is that design exploration, where design alternatives easily can be explored, is eased. Besides, there is another important advantage: the task of introducing a design for testability (DFT) method is eased too. This is because the model at high abstraction level includes fewer details and therefore the handling of design and test become easier.

7.2 INTRODUCTION

DFT is important to reduce the complexity of the test generation for a circuit (Fujiwara, 1985; Abramovici, Breuer, and Friedman, 1990). Various DFT methods have been proposed to augment a given circuit to become more easily testable. The most commonly used DFT method is scan technique (full or partial) (Cheng and Agrawal, 1990; Gupta and Breuer, 1990; Chickermane and Reddy, 1990) and built-in self test (BIST) (Chiu and Papachristou, 1991). However the hardware of full scan technique is large because all flip-flops are augmented and chained together into a scan path. Due to the area overhead, partial scan technique has been proposed in which only a subset of the flip-flops is included in the scan path. It can save area

overhead but maintaining a high fault coverage. BIST is a technique of designing additional hardware features into integrated circuits to allow them to perform self testing. Since the need for external automated test equipment (ATE) will be reduced, speed timing will be increased and lower cost of testing.

Scan technique and BIST have been proposed at gate level and high level. However, conventional scan techniques at gate-level which have long test application time due to scan in and scan out process. Therefore by applying DFT method at high-level for example which is at register transfer level (RTL), the number of primitive elements to be dealt in the circuit is reduced (Ghosh and Fujita, 2001). Thus the test generation time is also reduced. At RTL, various DFT methods that have been proposed are integrated automatic test pattern generation (ATPG) and DFT insertion technique using BIST (Carletta and Papachristou, 1995; Ghosh, Jha, and Bhawmik, 1998), scan design (Hsu and Patel, 1998; Huang, et al., 2001; Wada, et al., 2000) and test multiplexers (Dey and Potkonjak, 1994; Ohtake, et al., 2000). DFT at high level can be applied in the early design phase to improve the effectiveness of high-level ATPG. Moreover high level design can be described using an assignment decision diagrams (ADD) (Chaiyakul and Gajski, 1992). ADD is used in high level testing because it is easy for representing the RTL descriptions into its ADD model. Then the DFT method will be introduced to ADD.

In this chapter, we introduce a special class of ADD called thru-testable ADD. The new class of ADD is introduced at RTL which is at high-level based on the previous work that has been done in (Ooi and Fujiwara, 2006). Thru-testable ADD is a class of ADD which is easily testable. We also introduce a DFT method to augment a given ADD with thru functions so that the ADD becomes thru-testable.

7.3 R-GRAPH

In the previous chapter, *R-graph* is used to model a gate-level circuit. We also derived an R-graph which can model a high level design. R-graph is defined as an ADD representation by using read nodes as input and write nodes as output. The R-graph includes ADD properties of thru function, thru tree and input dependency. Based on these properties, the class of thru-testable ADD is defined.

Definition 1. Let X , Y and Z be a set of variables respectively in ADD where $X \cap Z = \emptyset$ and $Y \cap Z = \emptyset$. A **thru function** $t_{X \rightarrow Y}$ is a logic, equality, relational and arithmetic operations such that

- i. the operations connectives of the function consist of \wedge (AND), \vee (OR) and \neg (NOT), $<$ (LESS THAN), $>$ (MORE THAN) and $=$ (EQUAL);
- ii. the operation variables Z of the function and X consist of read nodes while Y consists of write nodes;
- iii. the signals at X transfer to Y if Z has an assignment that makes the thru function 'true' or active ($t_{X \rightarrow Y} = 1$).

Note that X and Y may have the same variables that make the thru function transfers the signal from one variable to the same variable. This thru function is called self thru function. In other words, thru function is a logic that transfers the same signals from the input to the output if the thru function is active. The bit width of the input and output are equal.

Example 1. Figure 7.1 shows two examples of thru functions. Two thru functions are independent if they cannot be active at the same time. Figure 7.1(a) shows that thru functions $t_{A \rightarrow B}$ and $t_{C \rightarrow B}$ are dependent. Dependent thru functions transfer signal at the same time and activated by same variable. In this case, signals from A and C are transferred to B at the same time when a_1 is true. Figure 7.1(b) shows that thru functions, $t_{A \rightarrow B}$ and $t_{C \rightarrow B}$ are

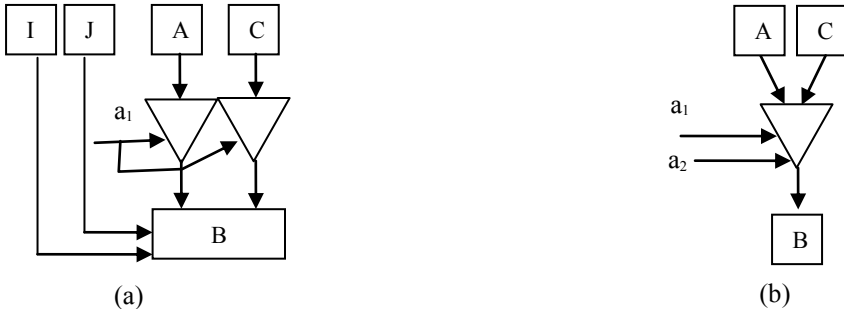

Figure 7.1 Thru functions.

independent. This means data transfer from A to B cannot happen at the same time when data transfer from C to B. The former takes place when a_1 is true.

To facilitate the implementation of our DFT method, we introduce a graph representation called R-graph which contains the information of connectivity, thru function of an ADD.

Definition 2. An R-graph of an ADD is a directed graph $G = (V, A, w, t)$ that has the following properties.

- i. $V \in V$ is a read node or write node. If a read node and a write node correspond to the same variable, they are represented by the same vertex;
- ii. $(v_i, v_j) \in A$ denotes an arc if there exists a path from the read node v_i to the write node v_j ;
- iii. $w:V \rightarrow Z^+$ (the set of positive integers) defines the size of read or write node corresponding to a vertex in V ;
- iv. $t:A \rightarrow T \cup \{0, I\}$ (T is a set of thru functions) where $t(u, v) = 0$ if there is no thru function for $(u, v) \in A$ and $t(u, v)$ is a thru function that transfers signals from the read node u to the write node v . If $t(u, v) = 1$ (also called identity thru function), the signal values are transferred from u to v

directly. Note that identity thru function is always active.

7.4 THRU TESTABILITY

Thru-testable ADD is a class of ADD which is easily testable. Its read nodes are easily observable and its write nodes are easily controllable. The class of thru-testable ADD is defined in the following text.

Using R-graph representation, we visualize a certain set of thru functions as a thru tree, which is defined as follow.

Definition 3. A thru tree is a sub graph of the R-graph such that

- i. it is a directed rooted tree;
- ii. there is only one sink (root), which has no outgoing arcs;
- iii. the sources are vertices that correspond to primary inputs without incoming arcs;
- iv. each arc is labeled with a thru function.

Example 2. Figure 7.2 shows a thru trees of the R-graph. Each arc is labeled with a thru function. The sources are represented by vertices that correspond to primary inputs without incoming arcs.

Definition 4. If V_{ti} is a set of vertices that activate a thru function t_i in a thru tree T_j , T_j is said to be dependent on V_{ti} . Furthermore, if V_{ti} includes a vertex in a thru tree T_k , T_j is said to be dependent on T_k .

Definition 5. Let G be the R-graph of ADD S , and let B be a set of thru trees in G . Let (u,v) be a set of all paths starting at u and ending at v . Two distinct paths $p_1, p_2 \in (u,v)$ have input dependency if the following conditions are satisfied.

- i. the first arc of one of the paths is different from the first arc of another path;

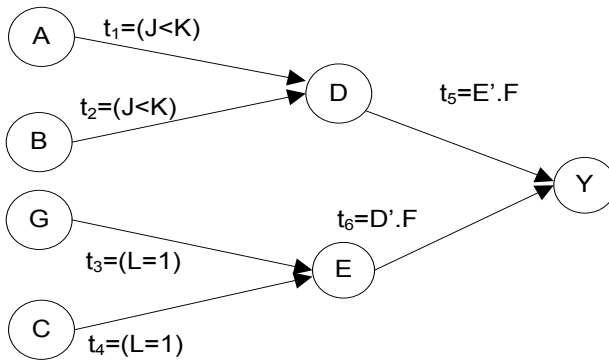

Figure 7.2 Thru trees of R-graph.

- ii. the first arc of at least one of the paths is labeled with a thru function in a thru tree in B ;
- iii. each path contains at most one cycle;
- iv. p_1 and p_2 have the same length.

Input dependency can be resolved by self thru functions. Using the newly defined concepts of thru tree and thru function, we can identify whether an ADD of an R-graph is thru-testable or not.

Definition 6. An ADD is called to be *thru-testable* if the R-graph of the ADD contains a set of disjoint thru trees such that the following conditions are satisfied.

- i. The thru trees cover all the vertices of a feedback vertex set.
- ii. For any thru tree T_i , T_i is not dependent on itself.
- iii. For any pair T_i, T_j of the thru trees, if T_i (resp. T_j) is dependent on T_j (resp. T_i), T_j (resp. T_i) is not dependent on T_i (resp. T_j).
- iv. For each pair of reconvergent paths p_1 and p_2 , p_1 and p_2 does not have input dependency.

The thru tree that does not depend on any vertex in any thru tree to become active is called independent thru tree.

Example 3. Figure 7.3(b) shows the R-graph of the ADD S1. Thru functions $t_3=C$ is activated by C. S1 is a thru-testable circuit because there are three thru trees, namely T_1 , T_2 and T_3 (shown in Figure 7.3(c)) that contain C, B and A which are the vertices in the feedback vertex set (FVS). Moreover, each variable that activate the thru functions in each thru tree is not a vertex in the thru tree. T_2 is dependent on T_1 because thru function t_3 in T_2 is activated vertex by C in T_1 . But thru functions in T_1 do not depend on any vertex in T_2 . There is also no input dependency in S1. Note that node C forms a self loop. Other loops are combination of nodes C, A and D and combination of nodes B, G and F.

7.5 EXTRACT THRU FUNCTIONS FROM A GIVEN ADD

Definition 7. Let A be a read node and B be a write node. A connects to data input of an assignment decision node (ADN) and B connects from the output of the ADN. If data transfer is allowed from path A to B then A is called on-path input.

Definition 8. Let A and B be read nodes and C be a write node. A and B connect to data input of the ADN and C connects from the output of the ADN. If data transfer is allowed from path A to C then B is called off-path input.

Thru functions are extracted from a given ADD and included in R-graph. The procedure consists of the following steps.

Step 1: Identify a set of ADD paths where each path contains one or more of the following

- 1.1 any input of addition node
- 1.2 the first input of subtractions node
- 1.3 any input of multiplication node

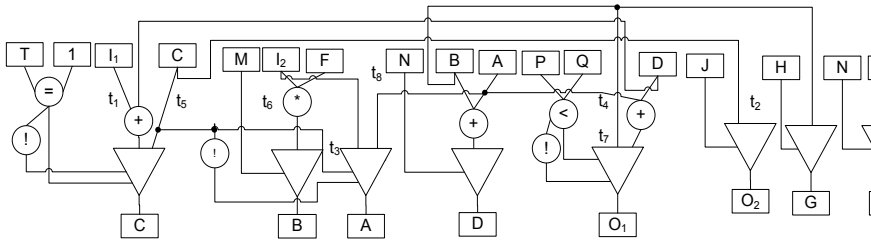

(a)

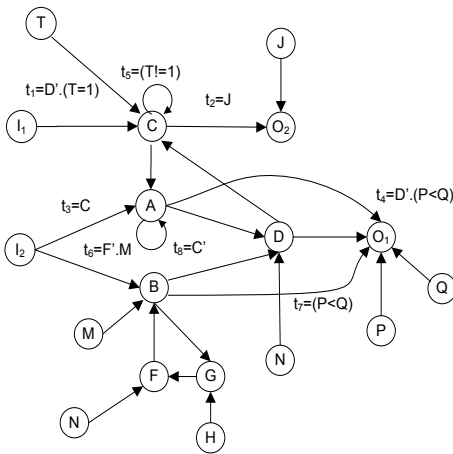

(b)

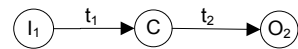

(a) T_1

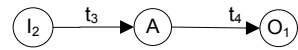

(b) T_2

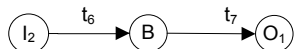

(c) T_3

(c)

Figure 7.3 R-graph of thru-testable ADD S1. (a) ADD S1. (b) R-graph of ADD S1. (c) Thru trees (T_1 , T_2 and T_3) for ADD S1.

- 1.4 the first input of division node
- 1.5 any data input of ADN.

Step 2: Compute the symbolic operations for each line in assignment value part and assignment condition part in terms of variable of read nodes. This is to obtain operational expression for each line. After the symbolic

operation of addition in Figure 7.4(a), the operational expression for line a is $(L+M)$.

Step 3: For each operation node (resp. ADN) on each ADD path, identify the logic, equality, relational and arithmetic operations or any combination of the operations that allows the data transfer from the input (resp. data input) of the operation node (resp. ADN) to its output.

3.1 For addition node and subtraction node, the conditions are inversion of the operational expression of the off-path input. For example, in Figure 7.4(a), in addition node in data of L is transferred to line a when the off-path input M is 0. (M'). In subtraction node, data of line a is transferred to line b when the off-path input N is 0 (N').

3.2 For multiplication node and division node, the conditions are the operational expression of the off-path input. In multiplication node in Figure 7.4(a), data of read node N is transferred to line c when the off-path input F is 1 (F).

3.3 For ADN, the condition is the operational expression of the condition input that corresponds to the on-path input. For example in Figure 7.4(a), data of line b is transferred to write node N when H is 1.

Step 4: Given a path from a read node to a write node, obtain the thru function by ANDing all the conditions that allow data transfer along the path. In Figure 7.4(a), thru function $t_{L \rightarrow N} = M' . N' . H$.

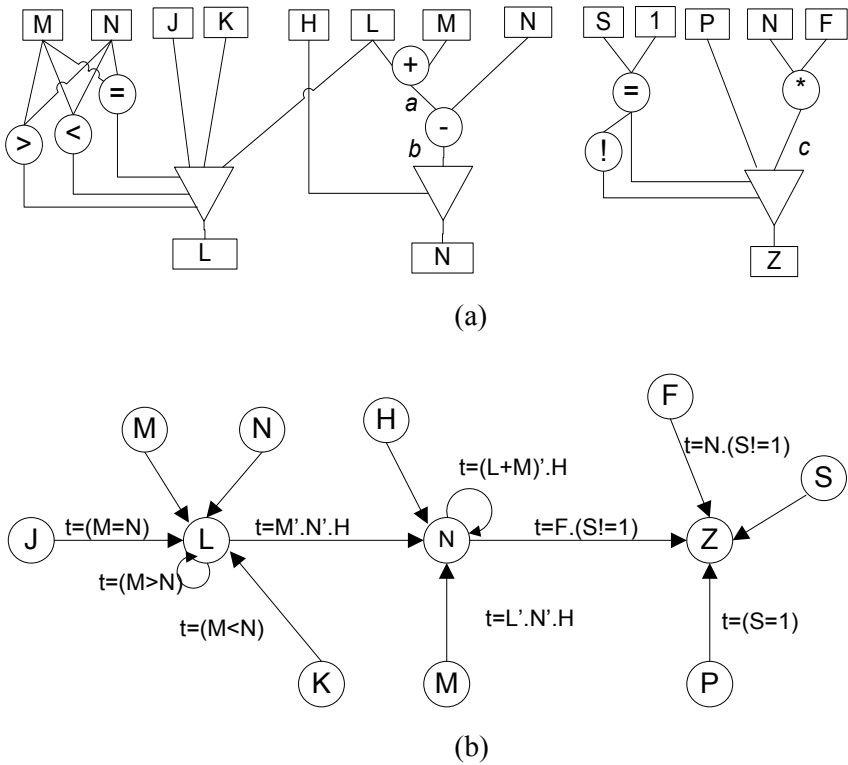

Figure 7.4 Thru functions extraction for ADD S2. (a) ADD S2. (b) R-graph for ADD S2.

7.6 DESIGN FOR TESTABILITY METHOD

Definition 9. Let A be an input vertex and B be an output vertex. Let C be a vertex which activates a thru function $t_{A \rightarrow B}$, C is called an activator. If the ADD of the R-graph is not thru-testable, we can augment the R-graph using our DFT method by adding minimum number of edges with thru functions into the R-graph. Therefore, the R-graph becomes thru testable. Steps for DFT method are taken as follows:

Step 1 Using depth first search, traverse from an input vertex to

the output vertex without considering whether the outgoing arc has a thru function or not. If the vertex is visited for second time, then the vertex is included in the feedback vertex set (FVS).

Step 2 For each vertex, choose the outgoing arc that has a thru function to continue the traversing. Otherwise the traversing is stopped.

Step 3 Group each thru function (TF) in the R-graph into set called TF_1, TF_2, TF_3 and onwards as follows

3.1 Initially include the first thru function into TF_1 .

3.2 For any i , include the current thru function into TF_i if the following conditions i&iii or conditions ii&iii are satisfied

- i. its input (resp. output) of the current thru function is same with the output (resp. input) of any thru function in TF_i .
- ii. its output of the current thru function is same with the output of any thru function in TF_i and the activators of the two thru functions are the same.
- iii. its activator is different from any input or output of the thru functions in TF_i .

3.3 Create a new TF_j ($j \neq i$) if necessary.

Step 4 Check whether all the vertices in feedback vertex set (FVS) are covered by the generated thru function set. If not, group those vertices into FVS' .

Step 5 For each vertex of FVS' , add a new thru function so that the output (resp. input) of the new thru function is the vertex of FVS' and input (resp. output) of the new thru function is one of the vertex of any existing thru function sets such that the output (resp. input) is not an activator for

any thru function in the set.

- Step 6 Repeat step 5 until all vertices in FVS' are covered by the generated thru function set. If FVS' is not empty, link the vertices with thru function such that a new thru function is formed.
- Step 7 Check whether each thru function set has a primary input and primary output vertex or not. Otherwise, one primary input vertex (resp. primary output vertex) in the R-graph is included into the set. If R-graph does not have one, a new vertex is added into the set.
- Step 8 Add a new thru function so that the input (resp. output) of the new thru function is the added new input (resp. output) vertex and the output (resp. input) of the new thru function is one of the vertices of any existing thru function sets.

Example 6. Figure 7.5 shows the thru functions that are introduced to make ADD S3 thru-testable. Vertices C, D and H are included in the feedback vertex set (FVS). 3 set of thru function (TF), i.e. $TF_1 = \{t_{A \rightarrow C}, t_{B \rightarrow C}\}$, $TF_2 = \{t_{C \rightarrow D}, t_{D \rightarrow E}\}$ and $TF_3 = \{t_{B \rightarrow G}\}$ have been generated. A new output vertex O_2 and a new thru function t_{new1} are added into R-graph of set TF_1 . Set of TF_2 has also two new thru functions t_{new2} and t_{new3} which are connected to vertex M and new output vertex O_3 . TF_3 are added with new thru functions t_{new4} and t_{new5} . Vertex H is included in set of FVS' because vertex H is not included in any generated thru function set. It is connected with vertex G and new output O_4 with new thru functions.

7.7 CASE STUDIES

ITC'99 benchmarks circuits described at RTL are used for the experiments. Design Compiler is used to obtain a gate level netlist

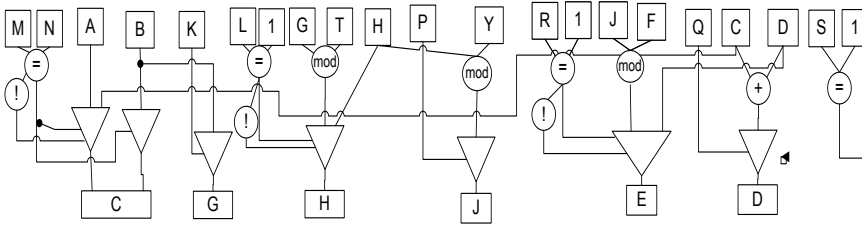

(a)

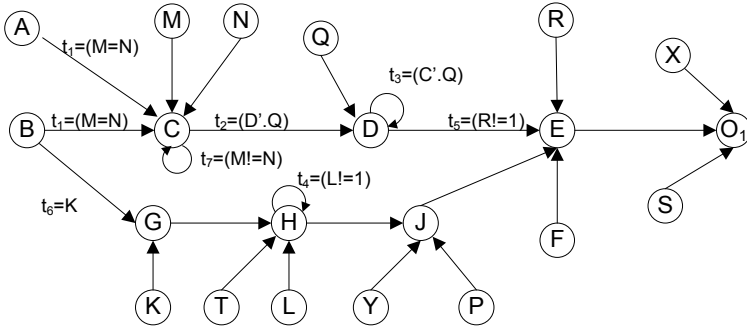

(b)

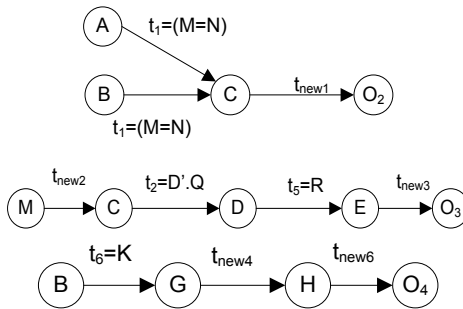

(c)

Figure 7.5 Thru functions that make S3 thru testable. (a) ADD S3. (b) R-graph of ADD S3. (c) Set of thru function sets (TF₁, TF₂ and TF₃).

circuit and Tetramax is used to generate test patterns for the circuits. We will show the comparison of our DFT method with

original circuits and conventional full scan technique circuits in terms of fault efficiency, area overhead, test generation time and test application time. We expect our proposed DFT method will obtain complete fault efficiency. We expect the area overhead of the circuit with our DFT will be higher than that of the original circuit but same with the full scan circuit. Less test generation time is expected in circuit with our DFT compared to the original circuit and full scan circuit. For test application time, it is less than the full scan circuit but not so more than the original circuit.

7.8 CHAPTER SUMMARY

In conclusion, the new class of ADD called thru-testable ADD has been introduced. The DFT method has also been introduced to augment a given ADD with minimum thru function so that the ADD becomes thru-testable. We expect our proposed DFT method will achieve complete fault efficiency, lower area overhead, less test generation time and less test application time. For future work, we are going to describe the test generation model for thru-testable ADD.

REFERENCES

- Abramovici, M., M. A. Breuer and A. D. Friedman. (1990). *Digital Systems Testing and Testable Design*. IEEE Press.
- Carletta, J. E. and C. Papachristou. (1995). Testability analysis and insertion of RTL circuits based on pseudorandom BIST. *Proc. Int. Conf. Computer Design*. :162-167.
- Chaiyakul, V. and D. D. Gajski. (1992). Assignment decision diagram for high level synthesis. *Technical Report*. :5-50.
- Cheng, K. T. and V. D. Agrawal. (1990). A partial scan method for sequential circuits with feedback. *IEEE Trans. Computer*. 39:544-548.
- Ooi, C. Y. and H. Fujiwara. (2006). A new class of sequential circuits with acyclic test generation complexity. *24th IEEE*

- International Conference on Computer Design.* : 25-431.
- Chickermane, V. and S. M. Reddy. (1990). An optimization based approach to the partial scan design problem. *Pro International Test Conference.* :377-386.
- Chiu, S. S. K. and C. Papachristou. (1991). A Built-In-Self-Testing approach for minimizing hardware overhead. *Pro International Test Conference.* :282-285.
- Dey, S. and M. Potkonjak. (1994). Nonscan design-for-testability of RT-level data paths. *Proc. Int. Conf. Computer-Aided Design.* :645.
- Fujiwara, H. (1985). *Logic Testing and Design for Testability.* MIT Press.
- Ghosh, I., N. K. Jha and S. Bhawmik. (1998). A BIST scheme for RTL controller/data paths based on symbolic testability analysis. *Proc. Design Automation Conf.* :554-559.
- Ghosh, I. and M. Fujita. (2001). Automatic test pattern generation for functional register-transfer level circuits using assignment decision diagrams. *IEEE Trans. Computer-Aided Design.* 20(3):402-415.
- Gupta, R. and M. A. Breuer. (1990). The BALLAST methodology for structured partial scan design. *IEEE Trans. Computer.* 39(4):538-544.
- Hsu, F. F. and J. H. Patel. (1998). High level variable selection for partial scan implementation. *Proc. Int. Conf. Computer-Aided Design.* :79-84.
- Huang, Y. et al. (2001). On RTL scan design. *International Test Conference.* :728-737.
- Ohtake, S., H. Wada, T. Masuzawa and Hideo Fujiwara. (2000). A non-scan DFT method at register-transfer level to achieve complete fault efficiency. *Proc. of Asia and South Pacific Design Automation 2000.* :599-604.
- Wada, H., T. Masuzawa, K. K. Saluja and H. Fujiwara. (2000). Design for strong testability of RTL data paths to provide complete fault efficiency. *Proc. 13th International Conf. on VLSI Design.* :300-305.