

A PRELIMINARY STUDY ON FDM PROTOTYPE SURFACE ROUGHNESS

**Shah Fenner Khan,
Ahmad Faizal Salleh**
School of Mechatronic, KUKUM,
Perlis, Malaysia

**Safian Sharif,
Zulkepli Mohamad**
Faculty of Mechanical, UTM, Johor,
Malaysia.

**Zulkifli A. Rashid
Muhamad Nasir Murad**
School of Manufacturing, KUKUM,
Perlis, Malaysia.

View metadata, citation and similar papers at core.ac.uk

brought to you by  CORE

provided by Universiti Teknologi Malaysia Institutional

Rapid prototyping (RP) is often used to describe the technologies that are used to fabricate physical objects directly from 3D CAD model. And sometime is also known as Solid Freeform Fabrication (SFF). These methods are generally similar to each other in that they add and bond materials in layer wise fashion to form 3 dimensional objects. Processes such as stereolithography (SLA), selective laser sintering (SLS), fused deposition modeling (FDM), layered object modeling (LOM) and 3D Printing (3DP) are part of this technology. This project study the effect of slice thickness and support parameters on the Water Soluble System, Fused Deposition Modeling (FDM) product quality in terms of surface roughness produced during part building. The results obtained show that slice thickness and support parameters influence the studied responses. The thickness of the support structures has affected the surface roughness obtained.

Keywords

Rapid prototyping ,Fused deposition modeling, parameters, quality , surface roughness, angular dimensional

1. INTRODUCTION

Relatively, Rapid Prototyping systems are faster as compare to other processes in producing prototypes. However, the surface roughness is affecting the cost, time and also application of the built prototypes. Surfaces that are produced need to go through some secondary processes in order to be acceptable for some industrial application such as for investment casting. In FDM, the surface roughness problem is not a new issue and it is obvious as compare to the other RP machines. The problem exists since the semi molten plastic raw materials are extruded through small nozzle and the influence of machine parameter settings. Thus, the assessment of parameter settings to produce the minimum surface roughness is critical. In this project, the support parameter and slice thickness is evaluated to understand it influence on prototype surface roughness.

2. METHODOLOGY

Few FDM parameters play important role in producing good surface finish prototypes. Researchers focus on how they could minimize the effect of those parameters on surface quality.

found that raster angle, air gap and interaction between the two factors contributed to the surface roughness of the part. Her results shown that surface roughness was most significant factors when raster angle was set at 0 degree.

Layer thickness plays a major role and has a very significant effect in determining surface quality of a part. [12] stated that lower level setting of layer thickness and tip size while orientation at high level gives good surface quality. Layer thickness became significant when the part has slope surfaces in the direction of build.

In the other study by Bharath et al [2], higher slope angle will produce better surface roughness due to the staircase effect. Increase in layer thickness results in a significance increase in the stair stepping effect which also results in an increase surface roughness.

3. MEASURING EQUIPMENTS AND LOCATIONS

Roughness is measured by special precision instruments, Mitutoyo Surftest, SJ-400, that measure the vertical deviations when traversing the surface. The Arithmetic mean value (Ra) is the most commonly used parameter to describe the average surface roughness and is defined as an integral of the absolute value of the roughness profile measured over an evaluation length. Measurement is taken perpendicular to the direction of the build layer. Surface finish measurement was done on the specimen's both side (top and bottom) and their locations are as shown.

Figure 1. Surface Roughness measuring locations A,B and C (Top Surface); C,D and E (Bottom Surface)

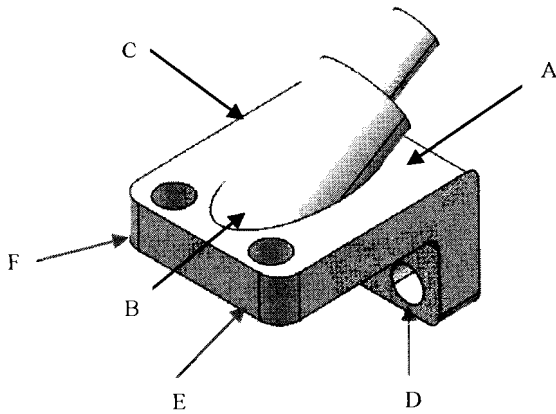

4. RESULTS AND DISCUSSION

4.1 Comparing surface roughness of each factor

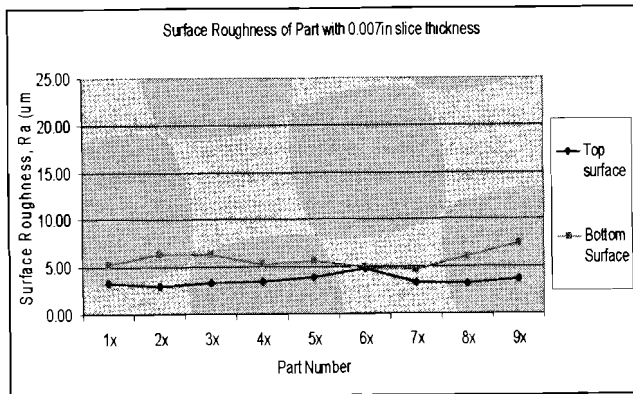

Figure 2. Comparison of Ra value of each part in 0.007in Slice Thickness

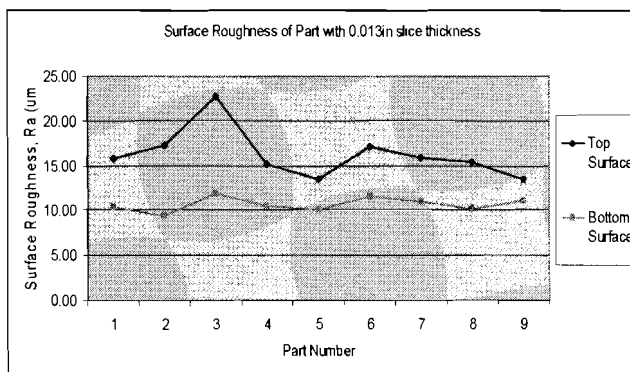

Figure 3. Comparison of Ra value of each part in 0.013in Slice Thickness

In the case of 0.007in, Bottom surface has higher Ra value as compare to Top surface. However, the reverse is true for 0.013in. When comparing between slice thicknesses, 0.013in gives higher Ra value as compare to 0.007in slice thickness.

Comparing in terms of Support styles, Sparse give the lowest Ra whereby Basic gives the highest Ra value. It can be concluded that the effect of Grow support is insignificance due to similar graph pattern for this response (comparing part 1,4,7 for All; 2,5,8 for None and 3,6,9 for Small). The following table simplifies the overall results obtained for this response.

Table 1. Interaction between factors and surface roughness

	High		Low	
	Top	Bottom	Top	Bottom
Slice Thickness	0.013	0.013	0.007	0.007
Support Styles	Sparse		Basic	
Grow Support	Insignificance			

5. CONCLUSION ON THE SURFACE ROUGHNESS

Analysis on the surface roughness was carried out for the top and bottom surface of the part. The slice thickness shows the most significant influence on part surface roughness. Part with bigger slice thickness will give higher Ra value. The result was in agreement with previous researcher, which found the lower setting of slice thickness gives higher surface quality [Azanizawati].

Results also show that for both surfaces, the existence of support structures influenced the part surface roughness. Basically, the top layer of a support column is built with a solid pattern of raster. The next several layers of the supports are built with a bigger size of structures. For the top layer, the size of single support structure is smaller than the slice thickness of the part produced with 0.013in but it is bigger than 0.007in. Therefore, for the part produced with 0.013in slice thickness, the part surface which is adjacent to the top layer of the support has smoother structure than to the surface without support structure. Since the existence of the support structure influencing the surface roughness, therefore, it is important to determine the orientation of the support on the prototype or the orientation of the part prior to its fabrication. When comparing each Support style and Grow support, the support parameters does not give any significant influence on the part.

Comparing the results obtained by Azanizawati using the FDM 2000 with BASS system, the Prodigy Plus with WS system gives better surface roughness. In the case of lower slice

thickness, the difference is around 200%. For higher slice thickness, the difference is around 70%.

- [6] International Journal of Machine Tools and Manufacture, 1998. 38:1257-1287
- [7] Emmanuel Sabourin, Scott A. Houser and, Jan Helge Bohn. "Accurate exterior, fast interior layered manufacturing." Rapid Prototyping Journal, 1997. 3 (2): 44-52

References

- [1] Nur Fazidah "Performance Evaluation Of Rapid Prototyping Process."
- [2] Azanizawati Ma'aram, Sa'ian Sharif, Khidzir Zakaria and Jafri Mohamed "Quality Assessment Of Hollow Prototypes Model in Fused Deposition Modelling". Master Thesis. Universiti Teknologi Malaysia; 2003.
- [3] M. Mahesh, Y.S. Wong, J.Y.H. Fuh and H.T. Loh. "Benchmarking for comparative evaluation of RP systems and processes." Rapid Prototyping Journal, 2004. 10(2):123-135.
- [4] J.P. Kruth. "Material in-process manufacturing by rapid prototyping technologies." CRIP Annals, 1991. 40(2): 603-614
- [5] D.T. Pham, R.S. Gault. "A comparison of Rapid Prototyping technologies."