

ESTIMATION OF SHIP MANOEUVRING CHARACTERISTICS IN THE CONCEPTUAL DESIGN STAGE

Mohd. Ramzan Mainal PEng MIEM MSNAME

Department of ThermoFluid
Faculty of Mechanical Engineering
Universiti Teknologi Malaysia

and

Mohd. Salim Kamil PEng MIEM

Royal Malaysian Navy
Ministry of Defence, Malaysia

ABSTRACT

In relation to the problems of the maritime safety, the diversification in ship types or the growth in ship sizes has enhanced the significance of manoeuvrability as one of the fundamental performances of ships. Namely it has become very important to predict the ship manoeuvrability at the stage of the initial ship design process. This paper presents a mathematical model for estimating the ship manoeuvring performance to cope with the increasing demands for conceptual design stage evaluation of safety in ship operation. The mathematical model developed can be extended further to be made applicable to various other problems such as low speed manoeuvres, lateral shifting stopping manoeuvres.

1.0 INTRODUCTION

Manoeuvring characteristics of ships are complex phenomena which include course keeping and turning ability. There are no simple criteria to rate the qualities of ships with respect to these characteristics. The associated flow phenomena are complex and often coupled to other phenomena. Course keeping in waves, for instance, is often connected to

rolling motion stability. Further complications are introduced by the environment (shallow water, bank effects, other traffic), the actual operating conditions of the ship and human aspects.

Manoeuvring characteristics have often been neglected during the conceptual design phase. Recently, an increased awareness of the importance of manoeuvrability for the safety of the ship and environment can be observed. Accidents such as with '*Herald of Free Enterprise*', in which manoeuvrability played some role, have certainly contributed to this increased interest [14]. Recognition of the importance of knowledge on the manoeuvring characteristics has for instance led to *International Maritime Organisation* (IMO) requirements for posting data on the characteristics at the navigating bridge of ships. In addition, it is expected that IMO will issue criteria for ship manoeuvrability in the near future.

Ship operators are very familiar with bridge simulators. These simulators are very sophisticated electronic gadgetry that allow the ship's crew to be trained at shore base on any particular class of vessel. The bridge is simulated either in day or night time operation, including all the instrumentation that is usual on the ship's bridge. The bridge simulator usually requires full scale trials to be conducted to provide manoeuvring information, which is then fed into a computer model of that particular ship. Thus the modification of the simulator to take allowance of a new ship type can be extremely expensive and equally time consuming. This type of simulator is of little use to a ship designer in the early stages of the design spiral. The designer should have a much simpler tool that allows immediate investigation of the characteristics of the new ship design.

With this fairly simple objective, a computer aided tool has been produced that requires only the use of a micro computer of moderate processing power. In essence this computer aided design tool is capable of helping the designer to investigate the effect that modifications to the ship design will have on the handling characteristics of the ship.

2.0 EQUATIONS OF MOTION

In this analysis, the ship is considered to be a rigid body, with only three degrees of freedom, that is, surge, sway and yaw. The ship motions in the other three degrees of freedom, roll, pitch and heave, are neglected and not considered in this treatment. It is convenient to describe the motions in terms of a Eulerian system of axes coincident with

amidship. This co-ordinate system is illustrated in Fig. 1 together with the basic nomenclature used. Thus, this gives rise to the equations of motion :

$$X = m(\dot{u} - rv - x_G r^2) \quad \text{Eqn. 1}$$

$$Y = m(\dot{v} + ur + x_G \dot{r}) \quad \text{Eqn. 2}$$

$$N = I_Z \dot{r} + mx_G(\dot{v} + ru) \quad \text{Eqn. 3}$$

In the above equation, the terms on the right hand side describe the inertial responses and those on the left hand side are the hydrodynamic forces and moments acting on the ship due to the motions which are usually expressed as perturbations about a steady ahead speed. These forces and moments are then assumed to be directly proportional to these perturbation quantities. Details of this procedure and its limitations are given in References [2] and [7].

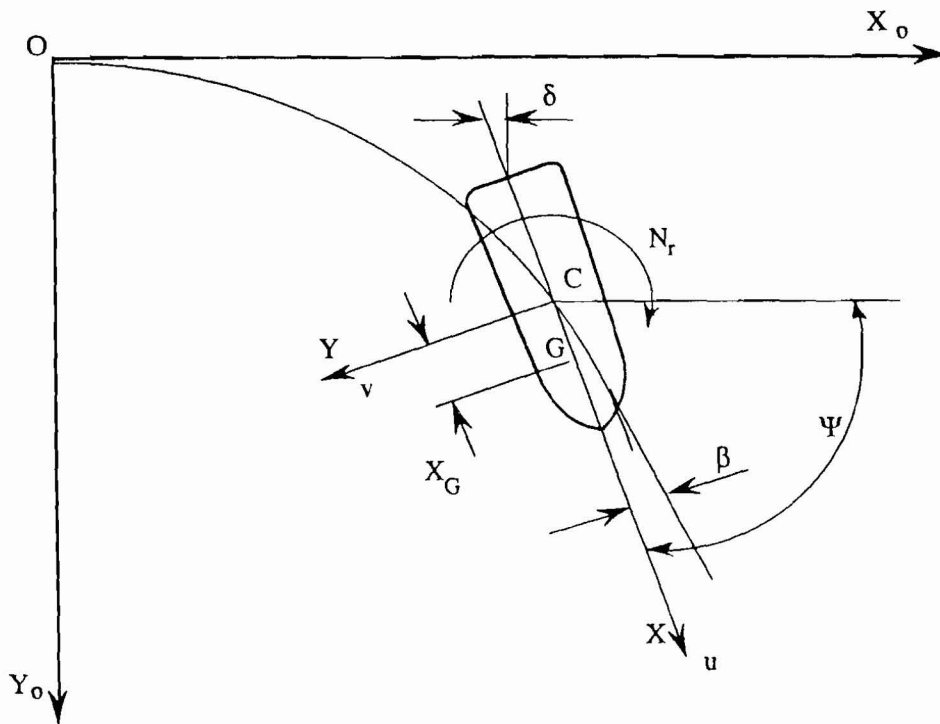

Fig. 1 Co-ordinate Axes System Adopted for Mathematical Modelling

Neglecting the non-dimensional terms, Eqn. 1 to Eqn. 3 may be expressed as :

$$X = X_{\dot{u}}\dot{u} + X_u\Delta u \quad \text{Eqn. 4}$$

$$Y = Y_{\dot{v}}\dot{v} + Y_v v + Y_{\dot{r}}\dot{r} + Y_r r \quad \text{Eqn. 5}$$

$$N = N_{\dot{v}}\dot{v} + N_v v + N_{\dot{r}}\dot{r} + N_r r \quad \text{Eqn. 6}$$

In all the terms in the above equations, the subscript notation refers to partial differentials with respect to that variables. For example

$$X_{\dot{u}} = \frac{\partial X}{\partial \dot{u}} \quad \text{and} \quad Y_v = \frac{\partial Y}{\partial v}$$

Expressing Eqn. 1 to Eqn. 3 in terms of the perturbation quantities and discarding all but linear terms in order to maintain consistency with Eqns. 4, 5 and 6, the following forms of linearised equations of motion are obtained :

$$(X_{\dot{u}} - m)\dot{u} + X_u\Delta u = 0 \quad \text{Eqn. 7}$$

$$(Y_{\dot{v}} - m)\dot{v} + Y_v v + (Y_{\dot{r}} - mx_G)\dot{r} + (Y_r - mu_0)r = 0 \quad \text{Eqn. 8}$$

$$(N_{\dot{v}} - mx_G)\dot{v} + N_v v + (N_{\dot{r}} - I_Z)\dot{r} + (N_r - mx_G u_0)r = 0 \quad \text{Eqn. 9}$$

No consideration has been given in the above treatment to the forces and moments created by rudder deflection. It is usual to assume that the rudder will give rise to a side force and moment which are directly proportional to the rudder angle. Following the addition of the rudder terms, Eqns. 7, 8 and 9 are more conveniently expressed in a dimensionless form, by dividing them with $\frac{1}{2}\rho u_0^2 L^2$ and $\frac{1}{2}\rho u_0^2 L^3$ respectively. This results in the usual form, the linearised equations of motion used in steering and manoeuvring

$$(Y'_{\dot{v}} - m')\dot{v}' + Y'_v v' + (Y'_{\dot{r}} - m' x'_G)\dot{r}' + (Y'_r - m')r' + Y'_\delta \delta = 0 \quad \text{Eqn. 10}$$

$$(N'_{\dot{v}} - m' x'_G)\dot{v}' + N'_v v' + (N'_{\dot{r}} - I'_Z)\dot{r}' + (N'_r - m' x'_G)r' + N'_\delta \delta = 0 \quad \text{Eqn. 11}$$

The dimensionless quantities in the above equations are given in Ref. (1).

Although Eqns. 10 and 11 expressed the linear equations of motion as pair of simultaneous first order differential equations, where the constant coefficients are dimensionless acceleration and velocity derivatives, it is possible to express these equations in an alternative form. It was first shown by Nomoto [3] that these equations can be written as a pair of decoupled second order equations as follows :

$$T_1 T_2 \ddot{r} + (T_1 + T_2) \dot{r} + r = K \delta + K' T_3 \dot{\delta} \quad \text{Eqn. 12}$$

$$T_1 T_2 \ddot{v} + (T_1 + T_2) \dot{v} + v = K_v \delta + K'_v T_4 \dot{\delta} \quad \text{Eqn. 13}$$

The terms in the above equations, and their algebraic relationships with the acceleration and velocity derivatives are given in Appendix.

It is common practice in the analysis of trial manoeuvres, both at full scale and with free running models, to use a more simple expression than that given in Eqns. 12 and 13. Nomoto first proposed an equation given as follows :

$$T \dot{r} + r = K \delta \quad \text{Eqn. 14}$$

3.0 MANOEUVRING CRITERIA

3.1 Turning Ability

When the turning ability of a ship is mentioned, it is usually described in the context of its turning circle as shown in Fig. 2. Measurements of the advance, transfer and diameter are quoted as a means of quantifying the ship's inherent turning stability. However, most ships, whether stable or unstable, turn with a circle diameter between two to three times the length of the ship, so that the terminal turning behaviour is not a useful means of assessing the manoeuvrability of a ship.

Before considering the turning circle, the initial turning ability of the ship will be examined, after the application of the rudder while following a straight course. In this way, the linear equations developed in the previous section may be used, since the deviations from the initial steady state are still small.

A suitable definition of turning ability can be taken as the heading angle turned through from an initial straight course, per unit rudder angle applied, after the ship has travelled one ship length. This situation is shown in Fig. 3 where the heading response to a rudder movement of angle δ in a time t_r , following which the rudder remains constant. The heading response can be obtained by solving the first part of Eqns. 12 and 13 for this rudder time history, together with zero rate and heading angle initial conditions, as follows

$$\frac{\Psi(t)}{\delta} = K' [t' - (T_1 + T_2 - T_3) + t'_r/2 + \frac{(T_1 - T_3)T_1^2}{(T_1 - T_2)t'_r} (e^{t'_r/T_1} - 1)e^{-t'/T_1} - \frac{(T_2 - T_3)T_2^2}{(T_1 - T_2)t'_r} (e^{t'_r/T_2} - 1)e^{-t'/T_2}]$$

Eqn. 15

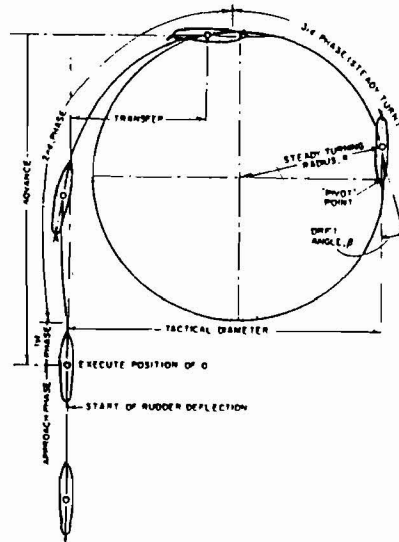

Fig. 2 Turning Path of a Ship

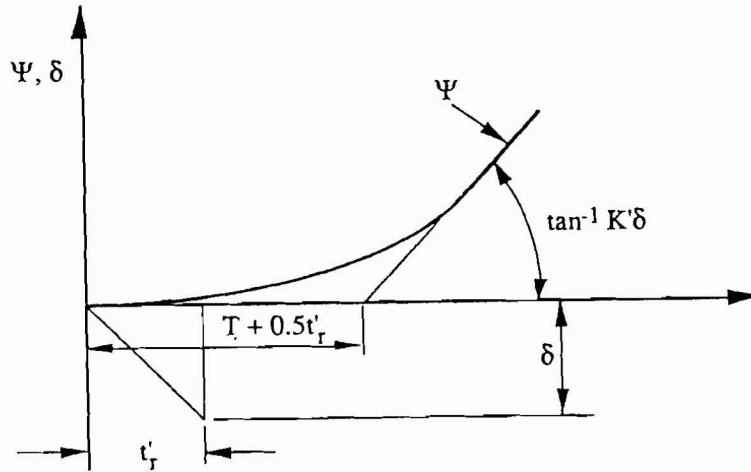

Fig. 3 Turning Ability of a Ship

Similarly, by solving Eqns. 12 and 13 for the same rudder input,

$$\frac{\Psi(t)}{\delta} = K' [t' - T' + t'_r/2 + \frac{T'^2}{t'_r} (e^{t'_r/T'} - 1) e^{-t'_r/T'}] \quad \text{Eqn. 16}$$

Study of Eqns. 15 and 16 confirms that both solutions tend to a similar asymptote if :

$$T' = T'_1 + T'_2 - T'_3 \quad \text{Eqn. 17}$$

If the time for the rudder movement tends to zero, and non-dimensionalised time is set to $t = 1$, (which is equivalent to moving one ship length), then Eqns. 6 and 7 become:

$$\begin{aligned} \frac{\Psi(t)}{\delta} = & K' [t' - (1 - (T'_1 + T'_2 - T'_3)) + \frac{(T'_1 - T'_3)T_1^2}{(T'_1 - T'_2)t'_r} T_1 e^{-t'/T_1} \\ & - \frac{(T'_2 - T'_3)T_2^2}{(T'_1 - T'_2)t'_r} T_2 e^{-t'/T_2}] \end{aligned}$$

and

$$\frac{\Psi(t)}{\delta} = K' [1 - T' + T' e^{-t/T'}] \quad \text{Eqn. 18}$$

Norrbin [2] first introduced the idea of a turning index and used Eqn. 18 to denote what he termed the 'P' number. This is the heading change per unit rudder angle for one ship length travelled, described in terms of the Nomoto indices K' and T' . Norrbin suggested a tentative value of $P > 0.3$ for vessels smaller than the tanker. A value of $P = 0.3$ is equivalent to a 10° heading change in one ship length, when the rudder is placed hard over in excess of 30° . Equation 9 may be expanded into the form

$$P = \frac{\Psi(t)}{\delta} = \frac{K'}{2T'} \left[1 - \frac{1}{3T'} + \frac{1}{12T'^2} - \frac{1}{60T'^3} + \dots \right] \quad \text{Eqn. 19}$$

and when T' is large this reduces to

$$P \cong \frac{K'}{2T'} \quad \text{Eqn. 20}$$

3.2 Dynamic Stability

For a linear dynamic system to be stable it is necessary for the roots of the characteristic equations to be negative. In most ship manoeuvring problems, these roots are usually real so that this requirement is satisfied if the time constants are positive. The condition for stability therefore reduces to :

$$Y'_v(N'_r - m'x'_G) - N'_v(Y'_r - m') > 0 \quad \text{Eqn. 21}$$

and may also be expressed as

$$\frac{N'_r - m'x'_G}{Y'_r - m'} > \frac{N'_v}{Y'_v} \quad \text{Eqn. 22}$$

This latter inequality is useful in defining the requirement for dynamic stability. It simply indicates that the centre of pressure in pure yaw should be ahead of the centre pressure in pure sway if the ship is to be dynamically stable.

4.0 ESTIMATION OF DERIVATIVES

At the present time, the most reliable method of determining the numerical values of the velocity and acceleration derivatives is by means of captive model testing, using either a planar motion mechanism or a rotating arm. However, this is an expensive and time consuming process and it would be a great advantage if the derivatives could be established empirically after analysis of experimental results obtained on planar motion and rotating arm devices.

In an attempt to clarify the situation, Clarke [1] performed a multiple regression analysis of all available data. His results are summarised in the following expressions for velocity and acceleration derivatives :

$$\frac{-Y'_v}{\pi\left(\frac{T}{L}\right)^2} = 1 + 0.40C_B B / T \quad \text{Eqn. 23}$$

$$\frac{-Y'_r}{\pi\left(\frac{T}{L}\right)^2} = 0.5 + 2.2B / L - 0.08B / T \quad \text{Eqn. 24}$$

$$\frac{-N'_v}{\pi\left(\frac{T}{L}\right)^2} = 0.5 + 2.4T / L \quad \text{Eqn. 25}$$

$$\frac{-N'_r}{\pi\left(\frac{T}{L}\right)^2} = 0.25 + 0.039B / T - 0.56B / L \quad \text{Eqn. 26}$$

$$\frac{-Y'_\dot{v}}{\pi\left(\frac{T}{L}\right)^2} = 1 + 0.16C_B B / T - 5.1(B / L)^2 \quad \text{Eqn. 27}$$

$$\frac{-Y'_\dot{\delta}}{\pi\left(\frac{T}{L}\right)^2} = 0.67B/L - 0.0033(B/T)^2 \quad \text{Eqn. 28}$$

$$\frac{-N'_\dot{v}}{\pi\left(\frac{T}{L}\right)^2} = 1.1B/L - 0.041B/T \quad \text{Eqn. 29}$$

$$\frac{-N'_\dot{\delta}}{\pi\left(\frac{T}{L}\right)^2} = 1/12 + 0.017C_B B/T - 0.33B/L \quad \text{Eqn. 30}$$

4.1 Estimation of Rudder Derivatives

The side force Y created by the rudder is calculated on the basis that the rudder acts like a low aspect ratio wing, so that

$$Y = 0.5\rho c^2 AC_L \quad \text{Eqn. 31}$$

where c is the water speed past the rudder, A is the rudder area and C_L is the lift coefficient. If this side force is non-dimensionalised in the usual manner by the factor $0.5\rho u^2 L^2$ then

$$Y' = \left(\frac{A}{LT}\right)\left(\frac{T}{L}\right)C_L\left(\frac{c}{u}\right)^2 \quad \text{Eqn. 32}$$

from which

$$Y' = \left(\frac{A}{LT}\right)\left(\frac{T}{L}\right)\left(\frac{\partial C_L}{\partial \delta}\right)\left(\frac{c}{u}\right)^2 \quad \text{Eqn. 33}$$

and since the rudder is approximately half the ship length aft of amidships,

$$N'_\delta = 0.5Y'_\delta \quad \text{Eqn. 34}$$

Although the lift curve slope of the rudder $\left(\frac{\partial C_L}{\partial \delta}\right)$ and the velocity ratio $(c/u)^2$ are variables which are different for every ship, their product has been assumed constant throughout this studies.

5.0 ESTIMATION OF TURNING CHARACTERISTICS

While the turning circle does not give a complete measure of the ship's manoeuvring performance, it has the advantage of having practical use to the ship's officers, is often important as a contractual requirement to the shipbuilder, and can be checked by measurement during trials.

In conformity with general practice, the turning circle characteristics discussed here have been non-dimensionalised using ship length. The terms used and the geometry of the circles are all defined in Fig. 3. In this study, the regression equations developed by Lyster and Knights [9] are used to estimate the steady turning diameter, tactical diameter, advance, transfer and the steady speed in the turn for any rudder angle. Following are the required equations for twin screw vessels :

$$\begin{aligned} \frac{STD}{L} = & 0.727 - 197 \frac{C_B}{|\delta|} + 4.65 \frac{B}{L} + 41.0 \frac{Trim}{L} + 188 \frac{1}{\delta} \\ & - 218 \frac{SpCh}{LT} (NR - 1) + 3.20 \frac{V_A}{\sqrt{L}} + 25.56 \frac{A_B}{LT} \end{aligned} \quad \text{Eqn. 35}$$

$$\frac{TD}{L} = 0.140 + 1.0 \frac{STD}{L} \quad \text{Eqn. 36}$$

$$\frac{Ad.}{L} = 1.10 + 0.514 \frac{TD}{L} \quad \text{Eqn. 37}$$

$$\frac{Tr}{L} = -0.357 + 0.531 \frac{TD}{L} \quad \text{Eqn. 38}$$

$$\frac{V_T}{V_A} = 0.543 + 0.028 \frac{TD}{L} \quad \text{Eqn. 39}$$

6.0 DESCRIPTION OF THE COMPUTER MODEL

A manoeuvring performance prediction tool for offshore supply vessels was created incorporating suitably adaptations of currently accepted practice. The resulting tool allows the user to determine the required size of rudder for a given vessel in order to provide adequate manoeuvring performance such as dynamic stability and the characteristics of the turning circle. The program in common with all computer programs may be broken down into a number of easily understood algorithms as shown in Fig. 4. The program requires only the following input values :

- a. ship parameters L, B, T and C_B
- b. initial ship speed
- c. centre of gravity of vessel
- d. depth of water
- e. number of screws
- f. radius of gyration of vessel

The program will calculate the velocity and acceleration derivatives and also evaluate the minimum rudder area according to Det Norske Veritas Rule [8] so that the rudder derivatives can be estimated. The program will proceed to evaluate the time constants and later check whether the vessel in question is stable or not (as defined by Eqn. 22).

From here, the user will have two choices, either to proceed with the unstable vessel or change the rudder area until a stable vessel is obtained and proceed to estimate the turning circle diameter.

A sample output of the computer program is given in Fig. 5.

7.0 CONCLUSION

In this paper, a design tool is developed that enables a designer to explore the effects on the manoeuvring characteristics of a ship at an early stage of the design spiral. The designer will only need basic information of the ship form to run the computer program.

This will help the designer to produce relevant data that will ultimately become necessary for regulatory bodies.

Against the background that there is no accepted method of describing and quantifying what is meant by the manoeuvrability of ships, this study has attempted to examine the consequences of simple criteria for manoeuvrability. However, it must be stressed that the method outlined in this study are based on linear equations of motion and are only valid for small departures from a steady course. It is well known that the correct mathematical modelling of ship manoeuvring behaviour requires complex non-linear equations. However, increasing the number of terms in the equations requires that many more coefficients will be needed to create a model for a particular ship. Defining these coefficients empirically at an early stage of a ship design is virtually impossible at present, without recourse to model testing.

NOMENCLATURE

A_B	-	submerged bow profile area	S_p	-	span of rudder
B	-	beam of ship	STD	-	steady turning diameter
C_B	-	block coefficient	T	-	draught
C_h	-	chord of rudder	u	-	speed of ship
D	-	depth of ship	V_A	-	velocity of approach
I_Z	-	mass moment of inertia	V_T	-	velocity of steady turn
L	-	length of ship	x_G	-	centre of gravity
m	-	mass of vessel	δ	-	rudder angle
NR	-	number of rudders	ρ	-	density of water

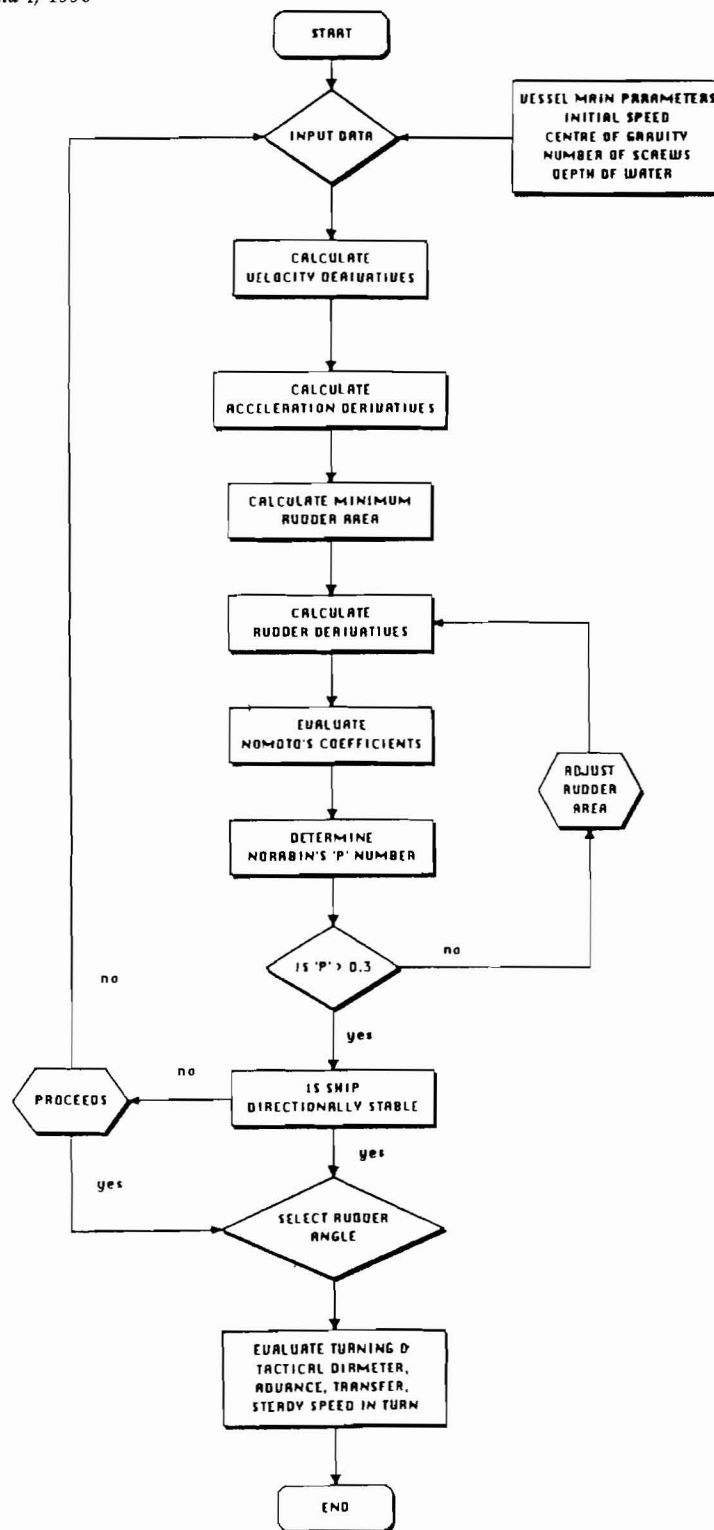

Fig. 4 Computer Flowchart of the Manoeuvring Characteristics

INPUT VERIFICATION .

LENGTH (m)	=	54.00
BEAM (m)	=	12.00
MEAN DRAFT (m)	=	4.20
BLOCK COEFFICIENT	=	0.68
CENTRE OF GRAVITY (m from midship)	=	0.037
INITIAL VESSEL SPEED (knot)	=	12.20
RADIUS OF GYRATION (m)	=	0.25 x L
WATER DEPTH TO VESSEL DRAUGHT RATIO (m)	=	1000.0
NUMBER OF PROPELLERS	=	2

LINEAR MANOEUVRING DERIVATIVES

NONDIMENSIONAL MASS	M PRIME	=	0.02293
NONDIMENSIONAL MASS MOMENT	I SUB ZZ	=	0.00143
SWAY VELOCITY DERIVATIVE	Y SUB V	=	-0.03378
SWAY ACCELERATION DERIVATIVE	Y SUB V DOT	=	-0.02013
YAW VELOCITY DERIVATIVE	N SUB V	=	-0.01305
YAW ACCELERATION DERIVATIVE	N SUB V DOT	=	-0.00242
SWAY VELOCITY DERIVATIVE	Y SUB R	=	0.00456
SWAY ACCELERATION DERIVATIVE	Y SUB R DOT	=	-0.00232
YAW VELOCITY DERIVATIVE	N SUB R	=	-0.00450
YAW ACCELERATION DERIVATIVE	N SUB R DOT	=	-0.00082
SWAY RUDDER DERIVATIVE	Y SUB DELTA	=	0.00527
YAW RUDDER DERIVATIVE	N SUB DELTA	=	-0.00263

TIME CONSTANTS AND GAINS FOR NOMOTO'S EQUATION

DOMINANT SHIP TIME CONSTANT	T1 PRIME	=	3.85727
SHIP TIME CONSTANT	T2 PRIME	=	0.38040
NUMERATOR TIME CONSTANT	T3 PRIME	=	0.82829
NUMERATOR TIME CONSTANT	T4 PRIME	=	0.27031
1ST ORDER EQN. TIME CONSTANT	T PRIME	=	3.40937
RUDDER GAIN FACTOR	K PRIME	=	2.67267
RUDDER GAIN FACTOR	K SUB V PRIME	=	1.29812
RUDDER AREA (m ²)	ARUD	=	5.12000

EVALUATION OF TURNING ABILITY AND STABILITY

CLARKE'S TURNING INDEX	P	=	0.39196
LINEAR DYN. STAB. CRITERION	C	=	-0.09506
COMMENTARY : VESSEL IS NOT COURSE STABLE			

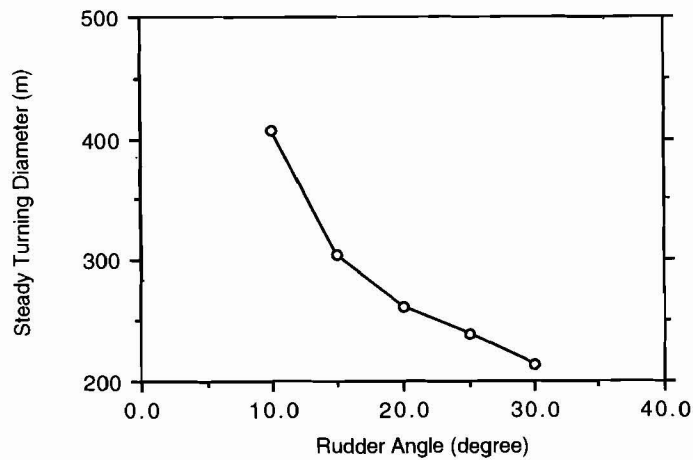

Effects of Rudder Deflection on Steady Turning Diameter

Fig. 5 Sample Output From the Computer Program

REFERENCES

1. Clarke, D., Gedling, P. and Hine, G., The Application of Manoeuvring Criteria in Hull Design Using Linear Theory, Proceedings of RINA Spring Meetings, London 1982.
2. Norrbin, N.H., Theory and Observations on the Use of a Mathematical Model for Ship Manoeuvring in Deep and Confined Waters, Meddelanden SSPA No. 68, Sweden, 1971.
3. Nomoto, K., Researches on the Manoeuvrability of Ships in Japan, Society of Naval Architects of Japan, 60th Anniversary Series Publication 1966, Vol. 11.
4. Wagner Smitt, L., Steering and Manoeuvring Full Scale Model Tests, European Shipbuilding 1970, Vol. 16, No. 6 and 1971, Vol. 2, No. 1.
5. Norrbin, N., Zig-Zag Test Technique and Analysis with Preliminary Statistical Results, SSPA Allmann Report, No. 12, 1965.
6. Inuoe, S, Hirano, M., and Kijima, K., Hydrodynamic Derivatives on Ship Manoeuvring, International Shipbuilding Progress, Vol. 28, No. 321, 1981.
7. Nomoto, K, Taguchi, T., Honda, K. and Hirano, S., On the Steering Qualities of Ships, International Shipbuilding Progress, Vol. 4, No. 35, 1957.
8. Det Norske Veritas, Rules for the Construction and Classification of Steel Ships, Oslo, 1975.
9. Lyster C.A., and Knights, H.L., Prediction Equations for Ships' Turning Circles, Trans. NECIES, 1979.
10. Argyriadis, D.A., Modern Tug Design with Particular Emphasis on Propeller Design, Manoeuvrability, and Endurance, Trans. SNAME,
11. Wilson, P.A. and Lewis, G.D.W., Predicting Ship Manoeuvring Characteristics for Preliminary Design, Proceedings of International Conference CADMO, 198

12. Inoue, S., Hirano, M., Kijima, K. and Takashima, J., A Practical Calculation Method of Ship Manoeuvring Motion, International Shipbuilding Progress, Vol. 28, No.325, 1981.
13. Balestrieri, R. and Biancardi, C.G., Computational Hydrodynamics and Ship Manoeuvring Characteristics, Proceedings of International Conference CADMO, 1988.
14. Dand, I. W., Hydrodynamic Aspects of the Sinking of the Ferry 'Herald of Free Enterprise', Trans. RINA, 1988.
15. Ogawa, A. and Kasai, H., On the Mathematical Model of Manoeuvring Motion of Ships, International Shipbuilding Progress, Vol. 25, 1978.