

Modeling and Characterization of Capacitively Coupled Interdigital-Gated HEMT Plasma Device for Terahertz Wave Amplification

Zon Fazlila Mohd Ahir, Ahmad Zarif Zulkifli and Abdul Manaf Hashim*
Material Innovations and Nano-Electronics Research Group, Faculty of Electrical
Engineering, Universiti Teknologi Malaysia, 81310 Skudai, Johor, Malaysia.

*e-mail: manaf@fke.utm.my (Abdul Manaf bin Hashim)

Abstract

A capacitively coupled interdigital-gated HEMT structure was used to investigate the occurrence of uniformity of electric field distribution along the structure. The structure was designed and simulated using Commercial Electromagnetic Sonnet Suites software. The return loss characteristics were analyzed and evaluated. The comparison of the admittance characteristics from simulation between dc connected structure and capacitively coupled structure is carried out in order to evaluate electromagnetic wave propagation. This structure kept uniform electric field in the channel when the dc biased is applied to the interdigital gate, which modulates the potential in the channel.

Keywords: Plasma wave; Interdigital; Negative conductance; HEMT; Terahertz

1. Introduction

In the recent year, solid-state devices operating in the so-called "Terahertz (THz) gap" region of electromagnetic waves are highly demanded for possible applications and so on. Above THz gap, we have well-developed solid-state sources such as infra-red laser and light emitting diode (LED). From the view point of the conventional electron approach, to fill the THz gap seems to be very difficult due to the limitations of high frequency signal detection/amplification usually come from carrier transit times. In traditional high frequency semiconductor devices, the operation frequency and handling power level are severely limited by the carrier transit time effect. This limitation can be lifted by utilizing distributed traveling wave interactions as in travelling wave tubes. Plasma wave interactions were successfully demonstrated

theoretically and experimentally in our previous works [1] utilizing interdigital-gated AlGaAs/GaAs HEMT structure. The theoretical results of our analysis on the interactions of the plasma waves with the electromagnetic space harmonic slow waves generated by interdigital slow-wave circuits indicated the occurrence of negative conductance in two-terminal interdigital admittance when the drift velocity slightly exceeds the phase velocity of the fundamental component of electromagnetic (EM) waves.[2]

Due to significant progress in semiconductor material and device technologies, frequencies handled by semiconductor device have been remarkably enhanced, approaching THz frequencies where transit time limitation of conventional devices now imposes very severe limitations on the frequency and power capabilities of devices. Such transit time devices with reduced gate lengths show severe short channel effects and large gate leakage current. Thus, it is unlikely that such conventional devices will achieve operation in the THz region with acceptable performance. With this background, the traveling wave concept has been reintroduced recently in the THz detector developed by Dyanakov and Shur. They also propose the use of plasma waves for wave detection in THz region at low temperature supported by a non-drifting 2DEG with an AlGaAs/GaAs heterostructure under a metal gate. [3]

The traveling wave interaction becomes more and more favorable at higher frequencies, particularly in the THz region where the negative conductance magnitude increase with the frequency. However, net negative conductance characteristics were not experimentally obtained in our dc-connected interdigital-gated structure as predicted [4,5]. In our analysis we found that net

negative conductance can be obtained if a uniform field distribution is realized [4,5].

In ref. [4], we propose the capacitively coupled interdigital-gate structure in order to realize uniform uniform field distribution under the interdigital gates. The purpose of the present paper is to characterize the capacitively structure by evaluating the S-parameter reflection.

2. Design of interdigital gates with capacitively coupled structure

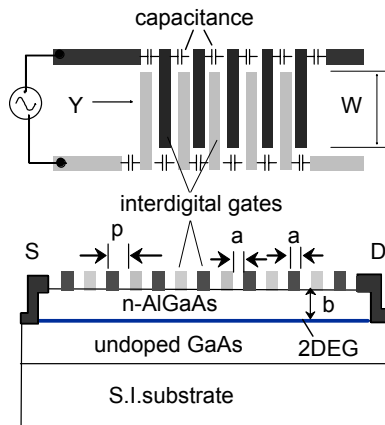

Fig. 1. Capacitively coupled HEMT structure

Figure 1 showed the device structure of capacitively coupled HEMT structure studied in this paper. The interdigital slow-wave circuits consist of two comb-like electrodes and have 25 pairs of fingers/channel with a finger pitch, p , of 5microns. The finger width and spacing are chosen to be the same and equal to a , so that p is equal to $2a$. This structure is similar to conventional HEMT in which a set of interdigital electrode act as a Schottky gate. A capacitively coupled HEMT structure was introduced in order to produce uniform field distribution. This structure will keep uniform electric field in the channel when the dc bias is applied to the interdigital gates which modulate the potential in the channel.

The structure was loaded with coplanar waveguide (CPW), which facilitates on-chip microwave probing. We are using Groud-Signal-Ground Cascade microprober in order to suit with CPW structure. The center conductor of CPW width was chosen to be $90\mu\text{m}$ and the gaps between the center conductor was $60\mu\text{m}$. The channel width, W was chosen to be $40\mu\text{m}$ and the length, L was chosen to be $100\mu\text{m}$. The thickness

of semi-insulating (SI) GaAs substrate used was chosen to be 0.625mm . The structure was designed on AlGaAs/GaAs high electron mobility transistor (HEMT) substrate. The dielectric loss tangent is 0.001 was used. The conductor used in this design is gold with thickness $0.05\mu\text{m}$. The fingers are capacitively coupled through SiO_2 layer (thickness= 300nm) only at certain part. This structure was designed using Commercial Electromagnetic Simulator Sonnet Suite software. The return loss characteristics were evaluated and analyzed.

3. Results and Discussions

An analysis of potential distribution of structure with dc-connected interdigital fingers is treated based on schematic cross-sectional view of interdigital structure shown in figure 2.

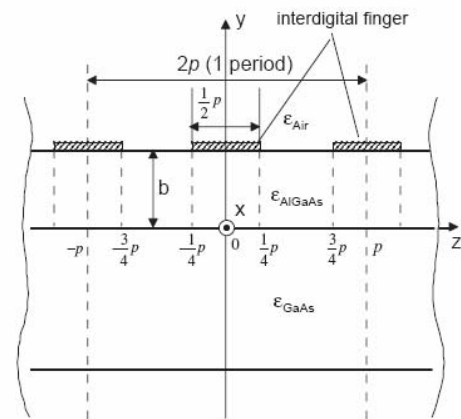
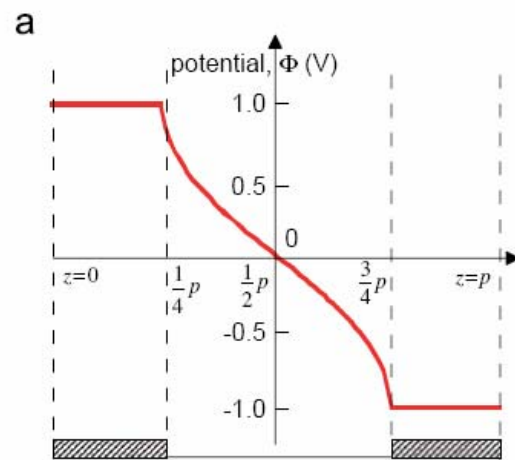

Fig. 2. Schematic cross-sectional diagram for potential distribution analysis.



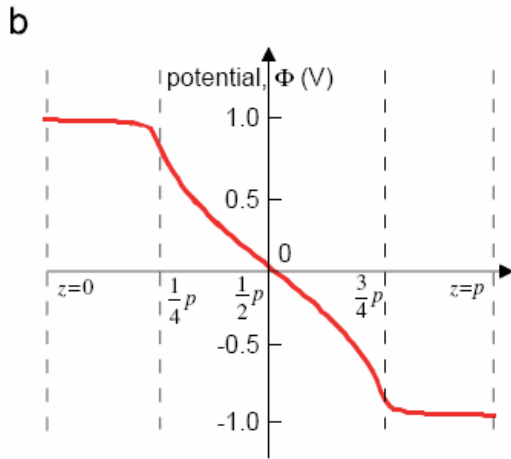

Fig. 3. Calculated potential distribution at plane (a) $y=b$ and (b) $y=0$ for a pair of finger ($p=5\mu\text{m}$, $V_0=1.0\text{V}$)

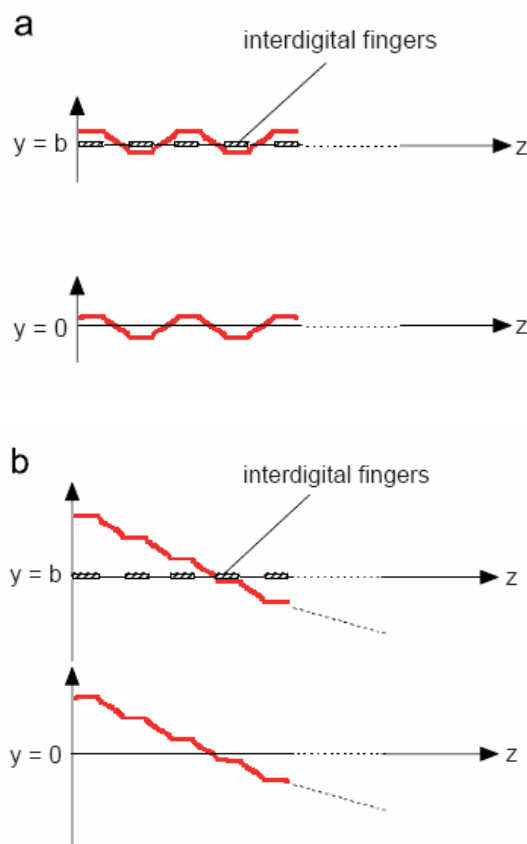

Fig. 4. Schematic figure of (a) potential array of dc-connected fingers (b) ideal potential array for uniform electric field distribution.

Here, for simplicity, there is no carrier flow in the channel. Interdigital fingers are located on a plane of $y=b$ and channel of electron flow is located on $y=0$ plane. The details of the mathematical treatment were presented in ref [6]. Here, we present the example of calculated potential distribution at these planes for a pair of fingers as shown in figure 3(a) and (b). The potential array for all fingers of device with dc-connected interdigital fingers is shown in figure 4(a). We believe that uniform carrier drift velocity should be realized if the potential array is arranged in the same slope or in the step-like distribution as illustrated in figure 4 (b).

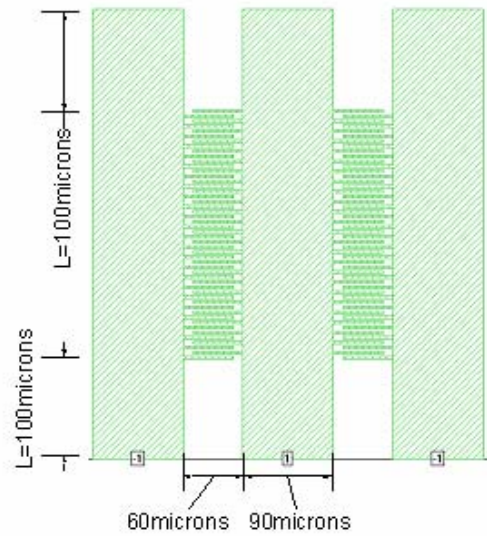

Fig. 5. An interdigital gates with dc connected structure.

Figure 5 was shown an interdigital gates with dc connected structure. This structure was simulated using EM software. The return loss characteristics were carried out and analyzed. The admittance characteristics were observed details in figure 6.

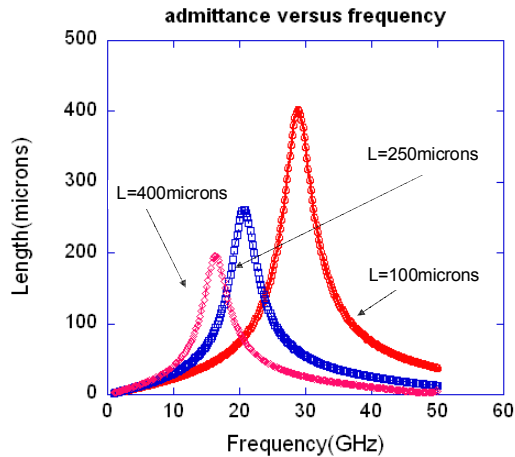

Fig. 6. Calculated conductance characteristics of interdigital gates with dc connected.

The calculated admittance for various lengths of dc connected structure was shown in figure 6. The result was simulated at low microwave frequencies in the range of 1-50GHz. From the fig. 6, it shown that the resonance frequency varies with the length, L. The resonance frequency reduce when increase the length. The admittance became smaller by increasing the length. The similar simulation also is carried out for capacitively coupled structure. The comparison of the admittance characteristics between dc connected structure and capacitively coupled structure is carried out in order to evaluate EM wave propagation. We are on the way to get the result by simulation and fabrication and the obtained results will be presented at the conference.

4. Conclusion

A uniform electric field distribution under the interdigital gates expected to be realized using a capacitively coupled interdigital structure. The reflections measurement of the structure is carried out in this paper. A uniformity of electric field distribution under interdigital gates was improved by making all fingers being capacitively coupled to each other.

5. References

- [1] A.M.Hashim, T. Hashizume, K.Iizuka and H.Hasegawa. Plasma wave interaction in the microwave to THz range between carriers in a semiconductor 2DEG and interdigital slow waves. *Superlattices and Microstructures* 34,531-537. (2003).
- [2] A.M. Hashim, S.Kasai, T. Hashizume and H. Hasegawa. Interdigital-gated HEMT structure for high frequency devices. *International RF and Microwave Conference Proceedings, Putrajaya Malaysia (2006)*
- [3] M.Dyakonov and M.Shur, *IEEE Trans Devices*, 46, 380 (1996)
- [4] A.M.Hashim, S.Kasai, T. Hashizume, K.Iizuka and H.Hasegawa. Novel structure of GaAs-based interdigital-gated HEMT plasma device for solid-state THz wave amplifier. *Microelectronics Journal*,38, 1268-1272 (2007)
- [5] A.M. Hashim, S.Kasai, T.Hashizume and H.Hasegawa, Large modulation of conductance in interdigital-gated HEMT devices due to surface plasma wave interactions, *Japanese Journal of Applied Physics* 44, 2729-2734 (2005).
- [6] A.M Hashim. Plasma waves in semiconductors and their interactions with electromagnetic waves up to terahertz region. *Ph.D Thesis, Hokkaido University, Japan, 2006.*