

ELECTROMAGNETIC TECHNOLOGY ON SEWAGE TREATMENT

Zularisam Ab. Wahid, Fadhil Othman, Johan Sohaili

Environmental Engineering Department,
Faculty of Civil Engineering,
Universiti Teknologi Malaysia

ABSTRACT

Magnetic treatments for water and wastewater attract a special attention due to their safety, ecological purity, simplicity and low operating costs. Thus this study was carried out in order to determine the feasibility and effectiveness of applying magnetic technology for a better understanding of the sewage characteristics. The main objectives of this research are to investigate the feasibility of magnetic technology in assisting sedimentation of suspended particles and to understand the mechanism and impact of magnetic application in sewage. The effects of various parameters, magnetic field strength, flow rate, usage of pin-jet and magnetic orientations are used to investigate their effectiveness on the suspended solids removal. A series of electromagnets magnets was used as a reactor in this study and the sewage was taken from Taman Sri Pulai, Johor with estimated PE of 10,300. Experiments indicate that suspended solids removal increases as magnetic field strength and exposure time are increased and flow rate is decreased. It was found out that magnetic field increases the suspended solids removal by 41 percent to 49 percent at 670 Gauss compared to untreated raw sewage. Besides that usage of pin-jet in the magnetically treatment reactors also help to increase another 6 percent of the suspended solids removal. Study carried out also shows that magnetic field enhances the suspended solids removal by accelerating the settling of sludge (settlement time) as well as increasing the sludge density. Hence this technology is definitely beneficial in reducing the volume of sedimentation tank as well as increasing the treatment plant efficiency.

Keywords : *Magnetic, Sewage, Treatment*

INTRODUCTION

Magnetic technology has been shown in the past to be a promising treatment process that can be used to enhance water and wastewater quality. Magnetic water treatment is a process of water that does not require any chemical and filtration substitutes. The scientific explanation of magnetic water treatment has been the subject of investigation by many researchers. These studies involved the formation of scale and methods for its prevention (Florenstano, 1996). Magnetic treatment of water is an attractively simple approach by which the water to be treated flows through a magnetic field and consequently changes some of its physicochemical properties.

Some researchers use particle of higher magnetic susceptibility to flocculate with particles (weakly magnetic and nonmagnetic particles) in the suspension and subsequently form paramagnetic flocs that can be removed by a magnetic filter. (Ying et al., 1999). This process is called magnetically seeded filtration and has been widely applied in the industrial wastewater treatment such as filtration of nuclear reactor coolant (Heitmann, 1979), removal of phosphate from water (Shaikh & Dixit, 1992), recovery of hematite and chromites fines and ultra-fines (Wang & Forssberg, 1994) and separation of dissolved heavy metals from wastewater (Terashima et al., 1986).

Usages of magnetite slurry, magnetic particles and magnetic powder in treating wastewater have becoming the main interest of many researchers. Commonwealth of Australia Scientific and Industrial Research Organization (CSIRO) has conducted a research onto the application of magnetic particle technology to wastewater treatment with respect to absorption and coagulation process (Bolto, 1990). This study was made on various numbers of wastewater applications such as metal recovery from electroplating rinse water, sewage sludge and hydrometallurgical effluents. Magnets had been used as the core element of a complete system to eliminate phosphate, heavy metals and other pollutants from wastewater. This system is based on attachment of wastewater pollutants to a magnetic carrier material (magnetite). After separation the magnetic is recovered and reused in the process. On the similar approach Sakai (1994) has studied the submerged filter system consisting of magnetically anisotropic tubular support media for sewage treatment with biofilm system. Activated sludge was supplemented with ferromagnetic powder for the preparation of the bilfilm. The biofilm was formed within 15 min on magnetic support media by magnetic attraction. The magnetic support media were able to treat wewage containing 0.2 g/l COD removing 72-94% COD with a retention time of 8h.

Previously most studies pertinent to magnetically treated wastewater were only concentrating on the usage of magnetite (magnetic particle and slurry). However, there are still lacks of studies that have been published regarding to the specific consumption of magnetic field effect on the sewage properties. Therefore it is the purpose of this study to investigate to the feasibility of magnetic technology in assisting sedimentation of suspended particles and to understand the mechanism and impact of magnetic application in the sewage.

Experimental Apparatus and Procedures

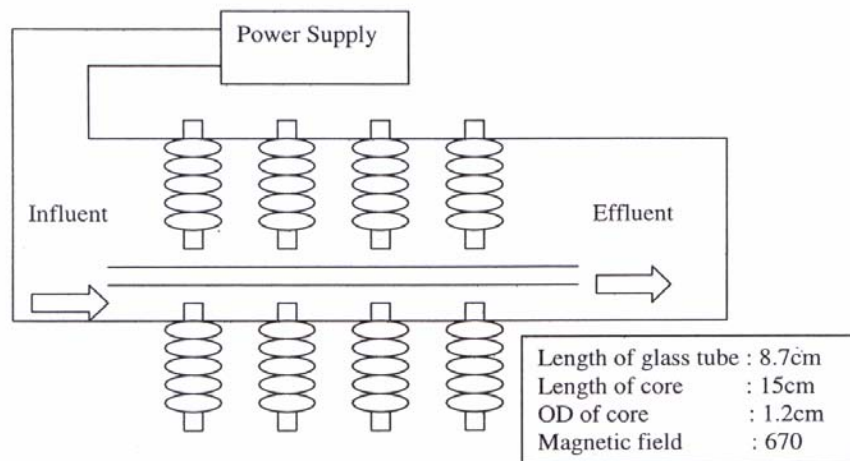

Figure 1 Schematic Diagram of Electromagnets

A Schematic diagram of electromagnetic experimental apparatus is shown in Figure 1. The electromagnetic reactor is designed with sixteen solenoids (coils of insulated wires wound in the form of a helix with iron cores). An electric current passing through the coil would induce a strong invisible magnetic field along the axis of helix. Each pole is producing 670 gauss that covers the length of 8.7 cm of magnetic field. This model is designed in such a way so that it will project a perpendicular magnetic field towards the flow of the untreated sewage. The influent of raw sewage was channeled through the tube by a pumping machine that can be set at various flow rates. The magnetically effluent was collected at the end of the tube of suspended solids analysis. Figure 2 shows the schematic layout of the whole treatment process. Samples of raw sewage were taken from the oxidation pond at Taman Sri Pulai, Johor Bahru, Johor.

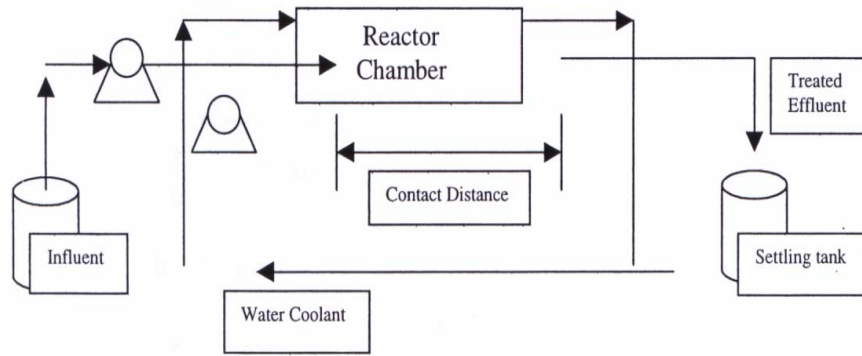

Figure 2 : Schematic Layout Of The Treating Process

Settling Analysis By Using Electromagnetic Reactor

In this experiment magnetic strength of 670 gauss was applied constantly throughout the treating process. A fixed flow rate of 1.41 ml/s was applied in order to create a 3 seconds interval exposure time in between the influent and magnetic field. The magnetically treated effluent was placed in a settling column that has a height of 45 cm and a diameter of 7 cm. This will consumed about 275 ml of treated effluent. Sampling was taken periodically every 30 minutes for suspended solids analysis. Pin-jet was used as an alternative device in this settling experiment. The pin-jet was placed at the end of the tube (effluent part). Figure 3 shows the schematic diagram of the pin-jet. The purpose of installing this device was to create a turbulence flow for the effluent. It is believed that such a drastic changes in the hydrodynamic flow would lead to better a decrement of suspended solids.

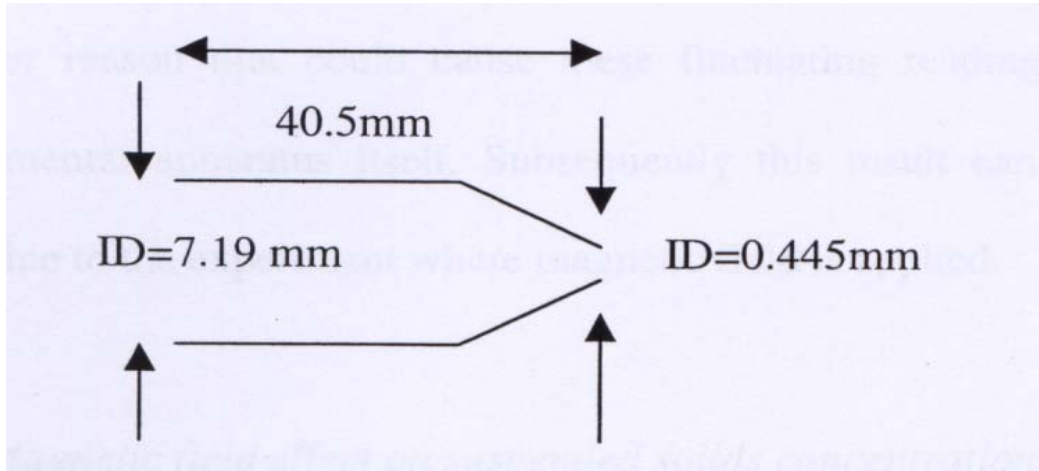

Figure 3 : Schematic Diagram of Pin-Jet

Experimental Results and Discussion

None Magnetic Effect Phenomenon

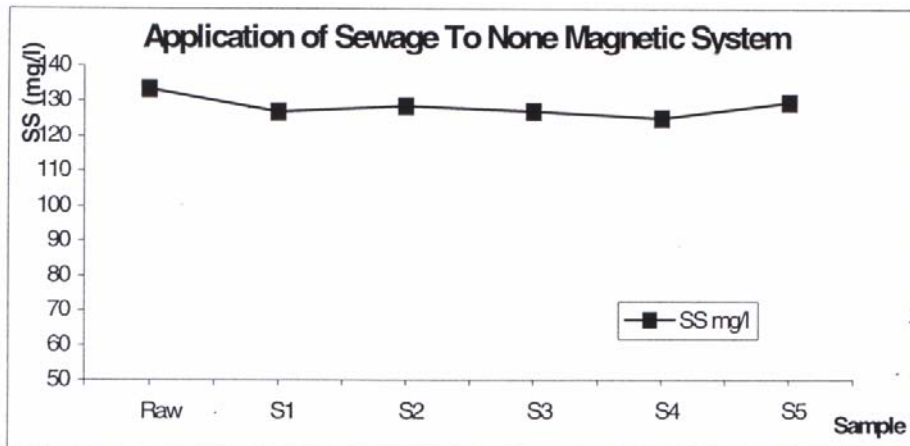

Figure 4 : Sewage is treated in none magnetic system

It can be seen from Figure 4 that reduction of suspended solids concentration still occurs although there was no magnetic field given in this experiment. This experiment was carried out at 0.145 ml/s and using a 0.4 cm internal diameter of a glass tube. The percentages of suspended solids removal are found to range from 3 percent to 6 percent. Theoretically there should be no reduction of suspended solids since no magnetic field was imposed. That fact is due to the experimental error that occurred during experiment. Another reason that could cause these fluctuating readings is due to the error of an experimental apparatus itself. Subsequently this result can be taken as a reference or guideline to the experiment where magnetic field is applied.

Magnetic Field Effect On Suspended Solids Concentration

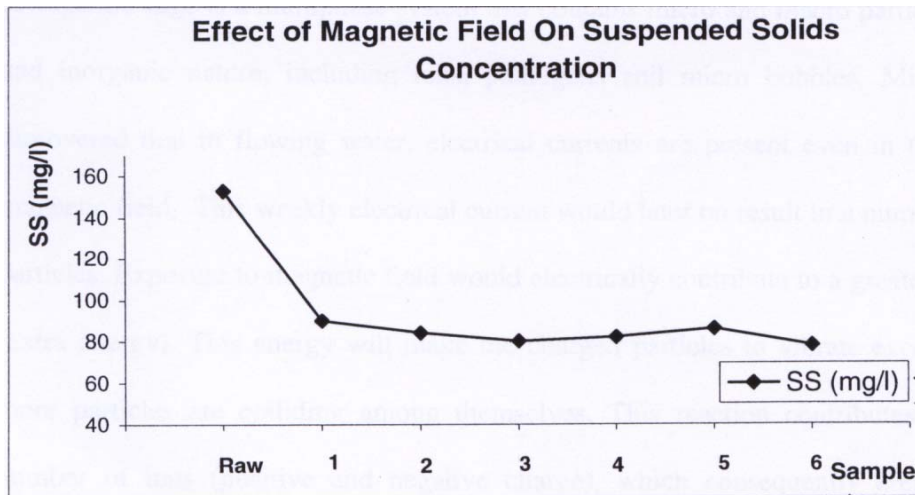

Figure 5 : Suspended Solids Concentration After Passing Magnetic Field

The effect of the magnetic field on the suspended solids concentration was found to be significant. This phenomenon is experimentally studied at 670 Gauss. The reduction behaviours can be seen obviously. As shown in Figure 5, the magnetic field enhances the suspended solids removal from 41 percent to 49 percent. The suspended solids of raw (153 mg/l) sharply decreases to 78 mg/l for the first sample, 84 mg/l for the second sample, 86 mg/l for the third sample, 82 mg/l for the fourth sample, 86 mg/l for the fifth and 78 mg/l for the sixth sample. This is a consequence of magnetic field effect on the sewage physical and chemical properties. Comparison between non-magnetically treated sewage (Figure 4) and magnetically treated sewage (Figure 5) can be made from this result.

How Does The Magnetic Field Acts On The Sewage

Based on the Figure 5 the magnetic field is proven to have the ability to treat the sewage. Sewage is a multiphase system that contains micro and macro particles of organic and inorganic nature, including ions, pathogens and micro bubbles. Michael Faraday discovered that in flowing water, electrical currents are present even in the absence of magnetic field. This weakly electrical current would later on result in a number of charged particles. Exposure to magnetic field would electrically contribute to a greater ionic charge (extra energy). This energy will make the charged particles to vibrate excessively. Thus more particles are colliding among themselves. This reaction contributes to additional number of ions (positive and negative charge), which consequently creates a natural magnetic attraction between the opposite charged particles. Particles are then attracted and cloaked together. This phenomenon intensifies coagulation that enables them to flocculate and precipitate when become heavier.

Effect of Flow Rate

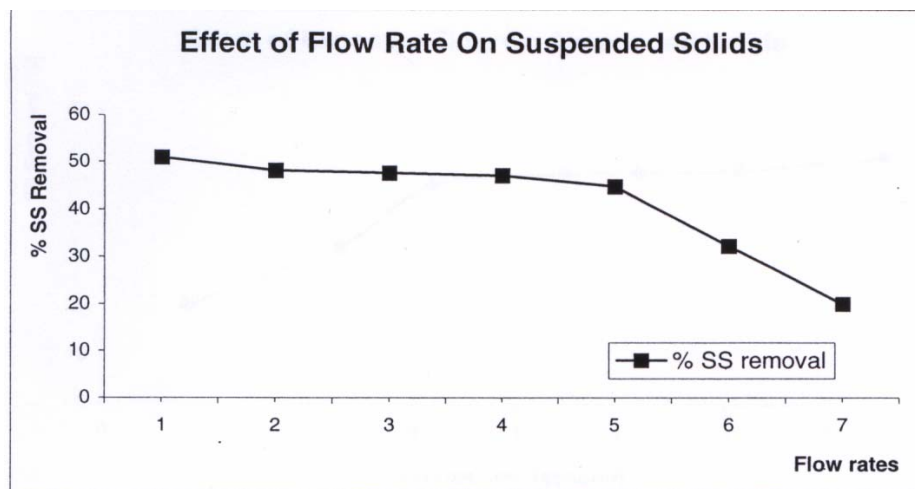

Figure 6 : Several Samples Being Tested Under Various Flow Rates

Effect of flow rate on the suspended solid removal is experimentally shown in Figure 6, where magnetizing works were conducted by varying the flow rate from 0.145 to ml/s to 1.344 ml/s. It is shown that the suspended solids removal is increased as the flow rate is decreased. Increased flow rate means increased in drag force. Therefore particles contained in sewage are not properly magnetized under this high flow velocity. For a lower flow rate reduction of suspended solids is found to be higher. The reason is that in slower flow rate sewage's particles received more magnetic fields thus more suspended particles are attracted and cloaked together. Consequently this behavior would contribute to extra reduction of suspended solids. As shown in figure 6, the experimentally observed removal increase from 20 percent (1.344 ml/l) to 40 percent (0.344 ml/l) and as the flow rate is decreased further, the suspended removal increased by about 6 percent from 1.344 ml/l to 0.145 ml/l.

Effect of Exposure Time

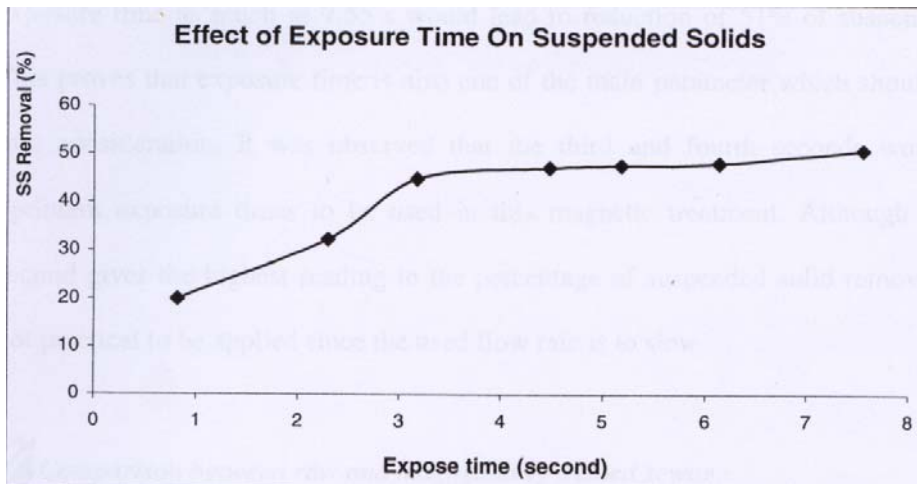

Figure 7 : Suspended Solids Concentration At Different Values of Exposure Time

In this experiment several flow rates were used to achieve several exposure time applied to the system. The exposure time obtained from the flow rate is described by the bellowed equation :

$$Q = V/t \tag{1}$$

In equation (1) Q is the flow rate, V is the volume of the tube and t is the exposure time. The magnetic strength used was 670 Gauss. It was observed that changes in exposure time would significantly effect the suspended solids concentration. Effluent that has longer exposure time gives better reduction compared to shorter. Longer exposure time means the charged sewage's particles received more ionic charge. This results in greater attractive forces among the suspended particles (positive and negative charged particles) and as this happened more particles are cloaked and settle down. It was found that exposure time as much as 7.55 s would lead to reduction of 51% of suspended solids. This proves that exposure time is also one of the main parameter which should be taken into consideration. It was observed that the third and fourth seconds would be the optimum exposure times to be used in this magnetic treatment. Although the eighth second gives the highest reading in the percentage of suspended solid removal but it is not practical to be applied since the used flow rate is too slow.

Comparison Between Raw and Magnetically Treated Sewage

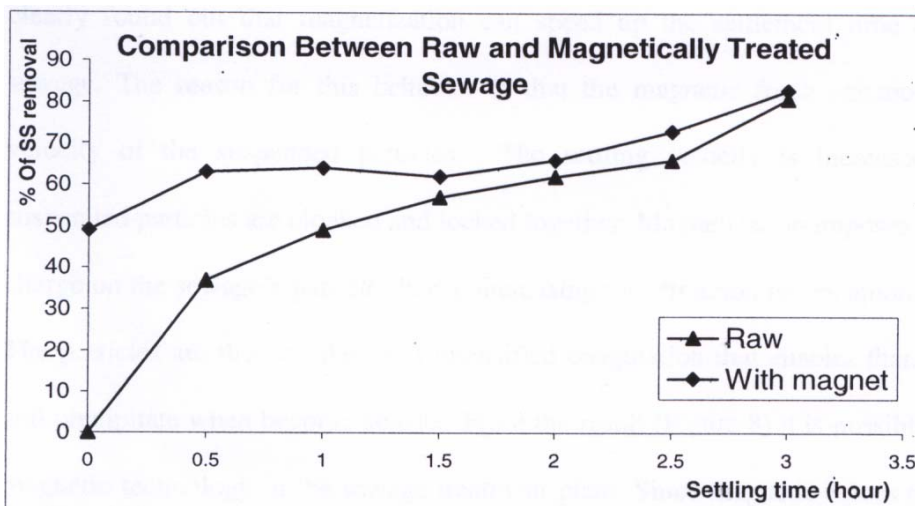

Figure 8 : Suspended Solids Concentration After Passing The Electromagnetic Reactor

A comparison experiment between magnetically treated sewage and raw was made in the settling analysis. Effect of magnetization on the sewage settling time was found to be significant. As shown in Figure 8, magnetized sewage has better suspended solids removal compared to raw sewage. This continues from the moment it is treated until 3 hour of settling time. Figure 8 shows that the magnetic field enhances the removal efficiency as much as 49 percent the moment it is magnetized and after 0.5 hour of settling time the suspended solids removal increases from 37 percent (raw sewage) to 63 percent (magnetized sewage). After 1 hour of settling time, the suspended solids removal increases from 49 percent (raw) to 64 percent (magnetized sewage). As the settling time is increased to 2.5 hour the percentage removal of suspended solids only increased by 4 percent to 7 percent from raw and magnetized sewage.

However, after 3 hours, the effect of magnetization on the suspended solids removal starts to wear off and the suspended solids removal is only 2 percent. From this result it is clearly found out that magnetization can speed up the settlement time of magnetized sewage. The reason for this behavior is that the magnetic force enhances the settling velocity of the suspended particles. The settling velocity is increased when more suspended particles are cloaked and locked together. Magnetization imposes a greater ionic charge on the sewage's particles hence increasing the attraction forces among the particles. The particles are then cloaked and intensified coagulation that enables them to flocculate and precipitate when become heavier. From the result (Figure 8) it is possible to apply this magnetic technology in the sewage treatment plant. Since magnetic forces can be used to accelerate the settling of sludge as well as increasing the sludge density this technology is definitely beneficial in reducing the volume of sedimentation tank.

Effect of Different Magnetic Strengths

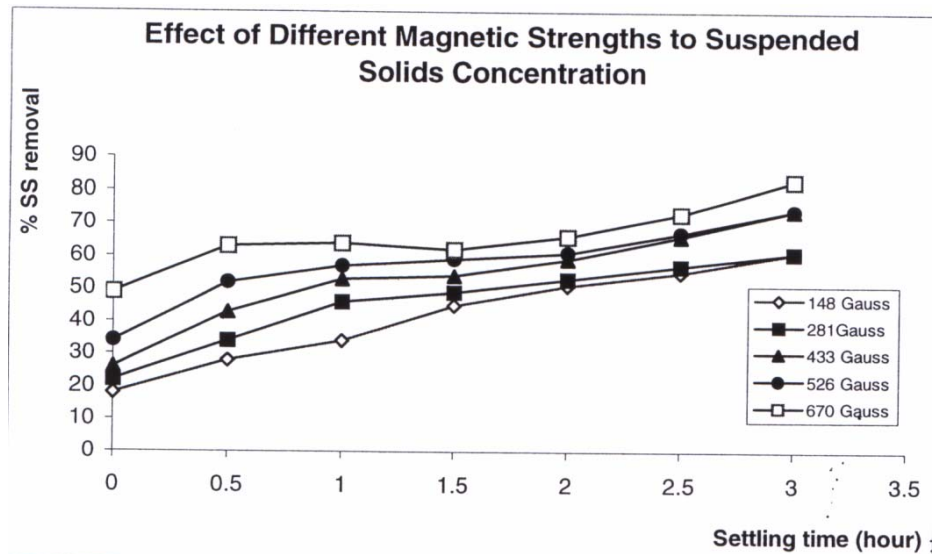

Figure 9 : Comparison Effect Among Several Magnetic Strengths To Suspended Solids

The effect of magnetic intensity on the suspended solids removal is experimentally studied by varying the magnetic field strength between 148 Gauss and 670 Gauss. It is shown that the suspended solids removal increases as the magnetic strength is increased. Figure 9 shows that at zero settling time suspended solids removal increases from 18 percent (148 Gauss) to 22 percent (281 Gauss) and becomes 26 percent (433 Gauss) to 34 percent (526 Gauss) and when the magnetic field reaches 570 Gauss the reduction turns to 49 percent. From 0.5 hour to 1.5 hour of settling time, the percentage of suspended solids removal increases by about 12 percent from 148 Gauss to 281 Gauss, 9 percent from 433 Gauss to 526 Gauss and 63 percent when reached 670 Gauss. After 2 hour of settling time the differences of suspended solids removal among the magnetic strengths seem to be smaller and this last till the third hour of settling time.

Usage of Pin-jet

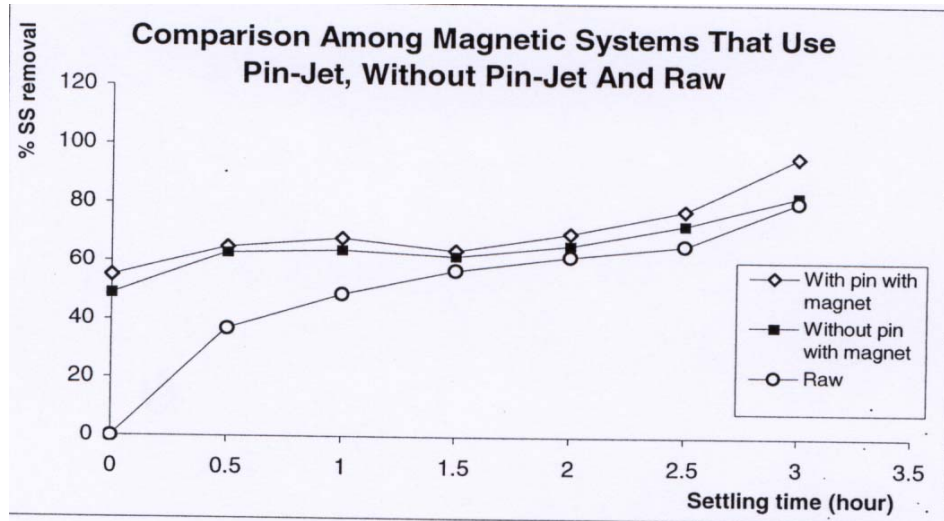

Figure 10 : Effect Of Pin-jet Used In The Magnetic System Compared To Raw

Effect of the pin-jet installed in the electromagnetic reactor on the suspended solid removal was found to be significant. It is clearly found out that suspended solids concentration is reduced up to 55 percent when sewage is channeled through the electromagnetic reactor that installed with a pin-jet. Figure 10 depicts efficiency of pin-jet usage in the system. Magnetically treated effluent with a pin-jet gives the highest percentage of suspended solids removal followed by non-pin installed magnetically treated effluent and raw sewage. As shown in Figure 10 the suspended solids removal increases from 49 percent (magnetically non-pin installed system) to 55 percent (magnetically pin-jet installed). Increment values of magnetically pin systems are ranging from 4.5 to 29 mg/l after each interval time and for magnetically non-pin used the value are ranging from 1.5 to 26.5 mg/l. Usage of pin-jet seems help to add another 6% of suspended solids removal in the magnetic system. The reason for this is that in a tight condition (narrow space) the distance among the charged particles are reduced and the attraction forces are greater. Thus more particles are cloaking together and consequently lead to more suspended solids removal.

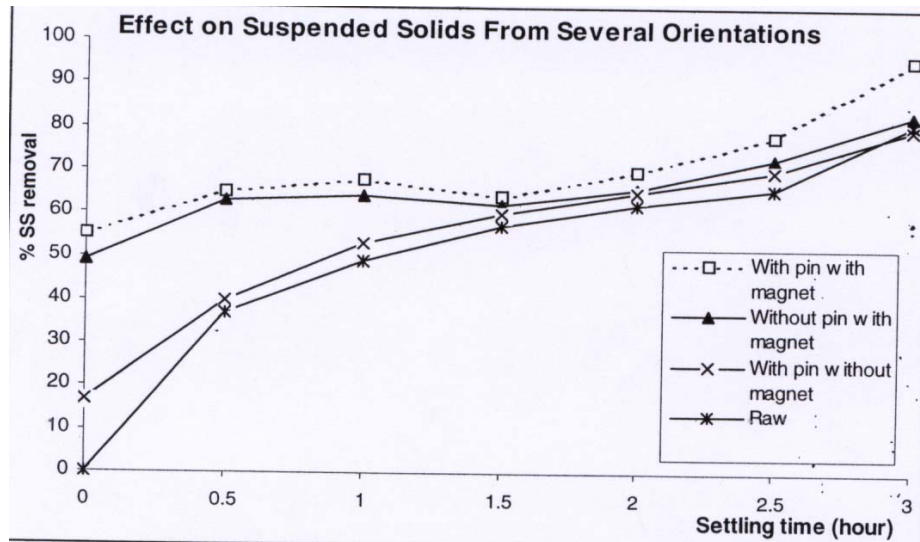

Figure 11 : Cumulative Relationship Among Several Magnetic Orientations

The cumulative relationship between several magnetic orientations is shown in Figure 11. Magnetically treated effluent with a pin-jet gives the highest percentage of suspended solids removal followed by non-pin installed magnetically treated effluent and non-magnetic system with installed turbulence pin and non magnetic system without turbulence pin. Suspended solids reductions for all orientations are found to be proportional with settling times. It was also observed that usage of pin-jet itself in the non magnetic system also help to reduce the suspended solids by 17% if compared the raw. The percentage of suspended solids removal becomes higher when pin-jet was used in the magnetic system (55%). Uses of pin-jet seem help to add another 6% of suspended solids removal in the magnetic system. But combination of magnetic field and pin-jet will definitely help for a better treatment of the sewage quality.

CONCLUSIONS

Magnetic technology is proven to be a promising treatment process that can enhance the suspended solids removal in the sewage. Study carried out shows that magnetic field enhances the suspended solids removal by accelerating the settling of sludge as well as increasing the sludge density. Hence this technology is definitely beneficial in reducing the volume of sedimentation tank as well as increasing the treatment plant efficiency. The main conclusions of this study are summarized below :

1. Sewage that is treated with magnetic field would result in decrement of suspended solids.
2. The percentage of suspended solids removal is increased as the flow rate is decreased.
3. Effluent that has longer exposure time (treatment time) gives better reduction in percentage of suspended solids compared to shorter.
4. Suspended solids removal increases as the magnetic strength is increased.
5. Magnetic field enhances the suspended solids removal in the sewage settling analysis by accelerating the settlement time for the magnetized sewage.
6. Usage of pin-jet provides further decrement of suspended solids removal in the magnetic treatment.

REFERENCES

- Bogatin, J., Bondarenko, N.P., Gak, E.Z., Rokhinson, E.E., Ananyev, I.P., (1999), Magnetic Treatment of Irrigation Water : Experimental Results and Application Conditions, Environmental Science Technology, v.33, n.8, pp. 1280 – 1285.
- Bolto, B.A., (1990), Magnetic Particle Technology For Wastewater Treatment, Waste Management, V.10, n.1, p11 – 21.
- Faseur, A., Vanbrabant, R., (1987), Electromagnetic Treatment of Wastewaters, particulate and Multiphase Processes. Volume 3 : Colloidal and Interfacial Phenomena, v.3, p.401 – 410.
- Florenstano, E.J., Marchello, J.M., Bhat, SM.; (1996) Magnetic Water Treatment In Lieu of Chemicals, Chemical Engineering World, v.31 n.10 p 133-136.
- Fridman, R.A., Rudnenko, E.V., (1982), Intensification of Biochemical Purification of Wastewater From Oligoesteracrylate Production By Magnetic Treatment, Soviet Journal of Water Chemistry and Technology, v.4, n.3 p110-112.

- Gehr, R., Zhai, Z.Z., Finch, J.A., Rao, S.R., (1995), Reduction of Soluble Mineral Concentrations In CaSO₄ Saturated Water Using A Magnetic Field, *Water Research*, v.29, n.3, pp.933-940.
- Heitmann, H.G. (1979), On The Hydrodynamic Resistance To A particle Of A Dilute Suspension When In The Neighborhood Of A Large Obstacle. *Chemical Engineering Science*, 26, 325-338.
- Powel, M.R.; (1998) Magnetic Water and Fuel Treatment: Myth, magic or Mainstream Science?, Committee for the Scientific Investigation of Claims of The Paranormal, Richland, Washington.
- Sakai, Y., Nitta, Y., Takahashi, F., (1994) A Submerged Filter System Consisting of Magnetic V/tubular Support Media Covered With A Biofilm Fixed By Magnetic Force, *Water Research*, V.28 n.5.p.1175-1179.
- Shaikh, A. MH., & Dixit, S.G. (1992). Removal of Phosphate From Waters By precipitation and High Gradient Magnetic Separation. *Water Research*, 26, 845-852.
- Terashima, Y., Ozkai., & Sekine, M. (1986). Removal of Dissolved Heavy Metals By Chemical Coagulation, magnetic Seeding and High Gradient magnetic Filtration. *Water Research*, 20, 537-545.
- T. Y.Ying, S. Yiacoumi, C. Tsouris (1999). High Gradient Magnetically Seeded Filtration. *Chemical Engineering Science*, 55, 1101-1113.
- Wang, Y., & Forssberg, E. (1994). The Recovery of Hematite and Chromites Fines and Ultrafines By Wet Magnetic Methods. *Minerals and Metal Processing*, 11, 87-96.