

A CRITICAL REVIEW OF THE REINFORCED CONCRETE COLUMNS AND WALLS CONCEALING RAIN WATER PIPE IN MULTISTOREY BUILDINGS

JAHANGIR BAKHTERI, Ph.D

WAHID OMAR, Ph.D

AHMAD MAHIR MAKHTAR, Ph.D

Department of Structures and Materials

Faculty of Civil Engineering

Universiti Teknologi Malaysia

ABSTRACT

Various problems and deficiencies in the strength and load carrying capacity of the reinforced concrete (RC) walls and columns caused by concealing PVC drain pipes within them have been identified. Alternative methods of positioning the drain pipes outside the columns are proposed. An improved method of the present practice has also been suggested. Finally, the research methodology and investigation of this problem which is presently in progress in the Universiti Teknologi Malaysia, Skudai, has been outlined.

INTRODUCTION

Tropical countries such as Malaysia are having heavy rainfall throughout the year, which requires an effective and proper drainage system in the construction of any new building project.

The drainage of rain water from the roof top of the buildings is always considered and properly handled in the Malaysian buildings construction. In many occasions rain water from roofs are drained through PVC pipes concealed in the RC walls and columns and taken out i.e. discharged at the ground level. However, considering the useful life of the structures, this method of drainage can be hazardous to the safety of the buildings.

Through the intensive experience of the first author in the Malaysian buildings industry, it has been observed sometimes that even in two storey bungalows which are usually supported by 125x125mm or 150x150mm RC columns, the drain pipes are positioned inside the columns. Though in these cases the loads might not be very high, but considering the size of the columns it might cause serious danger to the safety of the structures in the long-term.

PRESENT PRACTICE AND ITS SHORTCOMING

Concealing the PVC drain pipes inside the columns and walls in building structures is a common practice in Malaysian buildings. This condition has been imposed by the architects on the basis that projecting them outside the columns and walls will affect the appearance of the buildings.

However, concealing the drain pipes inside the columns and walls in buildings not only reduces the load carrying capacity of the columns and walls but could be very dangerous to the buildings safety as well. The dangers arising from the concealment of the rain water pipes in the building's columns and walls are as follows :

1. Positioning the drain pipe in the corner or at the edge of the column's section will virtually reduce the effective cross-sectional area of the column as indicated in Fig.1(a), (b), and (c). The pipe may not be held at central position in the column/wall, because during casting and vibrating of the concrete there are chances that the pipe may get an inclined position as shown in Fig.1(d), which will cause further decrease in load carrying capacity of the column / wall.
2. There are chances of honeycomb formation around the drain pipe in the column as shown Fig. 2.
3. The pipes may have leakage at their lapping parts or joints as indicated in Fig. 3, which in long-term can cause rusting of reinforcement in the structure hence, loss of bond and reduction in the strength of the structural elements .

4. Due to the presence of drain pipe in beam-column joints, the beam's reinforcement has to be bent as shown in Fig. 4, which causes irregularity and non-uniformity in the beam's reinforcement and hence a reduction in strength and functioning of the beam. The problem will be much critical in beams with higher percentage of reinforcement.
5. Elbow part of the pipe, which is used to drain the rain water at ground level may cause a huge reduction in the column's strength at base level. In the construction of building projects, occasionally it has occurred that the drain pipe has not been taken out at ground level i.e. the positioning of the elbow part of the pipe has been forgotten. To rectify this mistake, the concrete of the column's section at ground level has been hacked severely and then the elbow part of the pipe has been installed followed by grouting of fresh concrete as shown in Fig.5. However, the above mentioned method of rectification is very damaging to the robustness and safety of the structure.
6. In the case of RC walls, if the drain pipe is positioned at either end of the wall's section as shown in Fig. 6, it will be dangerous to the safety of the structure. This is because, the RC walls are mostly designed to resist lateral loads and are key elements in the building structures. Therefore, any deficiency at the end of the wall section which is usually a highly stressed zone in the wall, may cause a partial or full collapse to the structure.

PROPOSED SOLUTIONS

(a) Exterior Columns:

In the case of exterior columns in a building, the drain pipe can be placed outside the column's section and covered either in a concrete box section attached to the column or in a brickwork box section with concrete stiffeners as shown in Fig. 7. This method will be very helpful in case the drain pipe needs service at later stages.

(b) Interior Columns:

In the case of interior columns in a building, the drain pipes can be placed outside the column's section passing through the corner of

the floor slab. Again they can be covered either in a concrete box or in a brickwork box section as shown in Fig. 8.

- (c) Usage of steel pipe instead of PVC as an improvement of the present practice:
The usage of steel pipes instead of PVC pipes is another alternative, provided that the steel pipes must have a proper coating in order to avoid rusting. In this method the steel pipes can be positioned at the center of the columns' section, which will act not only as drain pipes but also as a replacement for the concrete removed from the section.
- (d) In concrete walls, the pipe can be placed at the middle third of the wall section preferably at the centroid of the section as shown in Fig. 9. This is because of the fact that mostly the extreme edges of the wall will have higher stresses than the middle part of its section. In case of any deficiency / failure in the wall around the drain pipe, the wall will virtually be converted to two walls with smaller sections rather than partial or total collapse of the wall. However, in this case as a precautionary measure additional reinforcement around the pipe should be provided.

EXISTING DESIGN PRACTICE

The columns concealing drain pipes are usually designed by the Malaysian practicing engineers on the basis of their reduced cross-sectional areas A_r which is calculated as follows:

$$A_r = A_g - A_p \quad (1)$$

where, A_r is reduced area of the section of the column, A_g is gross area of the column's section, and A_p is cross-sectional area of the drain pipe.

In case of the column with higher flexural stresses (i.e. moment), the assumption made in the effective depths of the column which contains drain pipe is usually inappropriate. This is because, for the design purposes, the practicing engineers assume an approximate effective depth for the column's section and a rational formula for the calculation of the effective depth of such type of columns is lacking.

ASSESSMENT OF LOAD CARRYING CAPACITY OF THE COLUMNS CONCEALING DRAIN PIPES

Assuming the column sections shown in Fig. 1 (a), (b) and (c) are having 350 x 350 mm, 400 x 400 mm and 450 x 600 mm cross-sections respectively and their respective drain pipes to be $\phi 50$, $\phi 75$ and $\phi 100$ (diameters in mm), if 6Y16 bars are used as vertical reinforcement in the column shown in Fig. 1(a), 4Y25 bars in column shown in Fig. 1(b) and 6Y25 bars in column shown in Fig. 1(c), then the probable effective cross-sectional areas of the columns will be:

$$\begin{aligned} \text{(a)} \quad & 350 \times (350 - 35 - 25 - 50) = 84000 \text{ mm}^2 \\ \text{(b)} \quad & 400 \times 400 - (35 + 25 + 75)2 = 141775 \text{ mm}^2 \\ \text{(c)} \quad & 450 \times (600 - 35 - 25 - 100) = 198000 \text{ mm}^2 \end{aligned}$$

Using equation (1) the effective areas for the above three columns used by practicing engineers in the industry are 120536 mm², 155582 mm² and 262146 mm² respectively.

Assuming these columns as short braced columns with minimum moment, the maximum axial load capacity of each column can be calculated using equation 39 of the BS 8110: Part 1 (clause 3.8.4.4) reproduced below as equation (2).

$$N = 0.35f_{cu}A_c + 0.67A_{sc}f_y \tag{2}$$

Where, A_c is the net concrete area, A_{sc} is steel area, f_{cu} and f_y are characteristic strengths of concrete and steel respectively. In the present study the strengths are assumed as $f_{cu} = 35 \text{ N/mm}^2$ and $f_y = 460 \text{ N/mm}^2$ and 25 mm nominal concrete cover to the links of all columns which are assumed to be 10mm bars.

The maximum load carrying capacity of the above mentioned columns considering the two different effective cross-sectional areas are calculated and presented in Table 1. The values in the table are obtained by using Equation (2) and their differences in percentage have also been indicated.

Table 1 Maximum Axial Load Capacity of Columns Using Equation (2)

Column shown in Fig.	Columns's exterior dimension (mm)	(A) Column's axial load capacity on the basis of Industry's effective area (kN)	(B) Column's axial load capacity using effective area by present study (kN)	Differences in percentage between the two axial load capacities (A) & (B)
----------------------	-----------------------------------	---	---	---

1 (a)	350 x 350	1850	1441	28.38%
1 (b)	400 x 400	2514	2345	7.21 %
1 (c)	450 x 600	4124	3338	23.55 %

Table 1 indicates that the industry engineers assume the axial load capacity of columns as high as 28% in comparison to the present case which can be a threat to the safety of the structure.

RESEARCH METHODOLOGY

- (a) Investigation is undertaken to estimate the reduction in load carrying capacity of column containing drain pipe including elbow part
- (b) Research is going on to study the effects of drain pipes on the slenderness of the columns.
- (c) The investigation will also determine the effects of drain pipes on the buckling mode of columns.
- (d) Methods of Research :
 - (i) Experimental method : Testing of various scaled models with different sizes of drain pipes including elbow part.
 - (ii) Numerical method : Finite Element Modeling and Analysis of the tested models to validate the experimental results.

CONCLUDING REMARKS

In this paper a critical review of the ongoing practice of concealing drain pipes inside the RC column and wall sections in the Malaysian buildings' industry has been provided. Since a rational and reliable design formula for the calculation of load carrying capacity of the affected columns is not available, it is therefore recommended that the proposed alternative solutions may be adopted.

The probable effective areas such as those shown in Fig. 1(a), (b) and (c) can also be adopted for design purposes as a second alternative tentatively. This will reduce the threat to the safety of structure.

The research initiated at UTM will assess the actual load carrying capacities of columns concealing drain pipes including their elbow parts. On the basis of outcome of this research it will be possible to provide an approximate but realistic formula for the design of such columns.

REFERENCES

BS 8110 : Structural use of concrete, Part 1 : Code Of Practice For Design And Construction, Part 2 : Code Of Practice For Special Circumstances, British Standards Institution, London, 1997.

Reynolds, C.E. and Steedman, J.C. Reinforced concrete designer's handbook, London, E. & F.N. SPON, 1988.

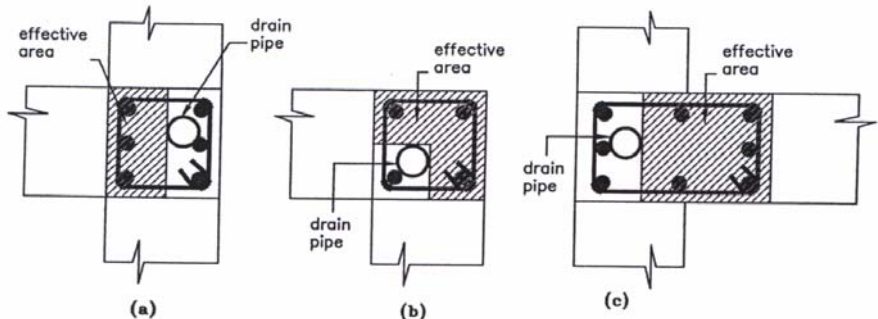

Column sections in plan showing the probable effective areas

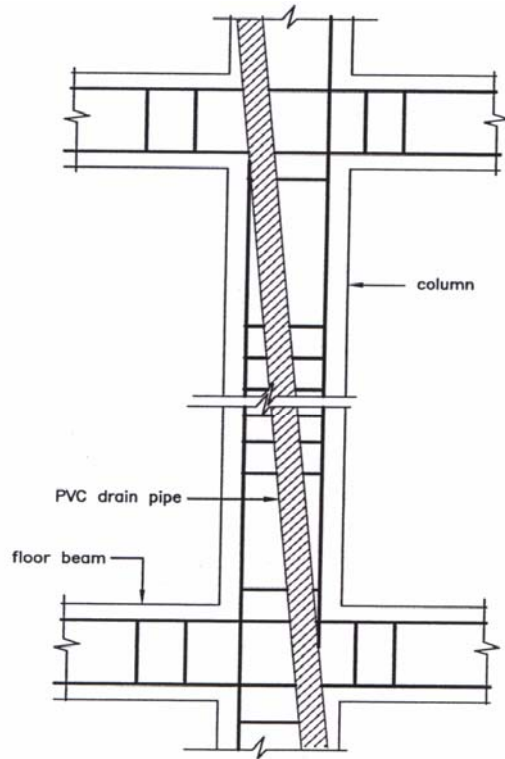

d) Vertical section of column showing the inclined positioning of the drain pipe

Fig. 1 Inappropriate Positioning of Rain Water Pipe In Column's Section

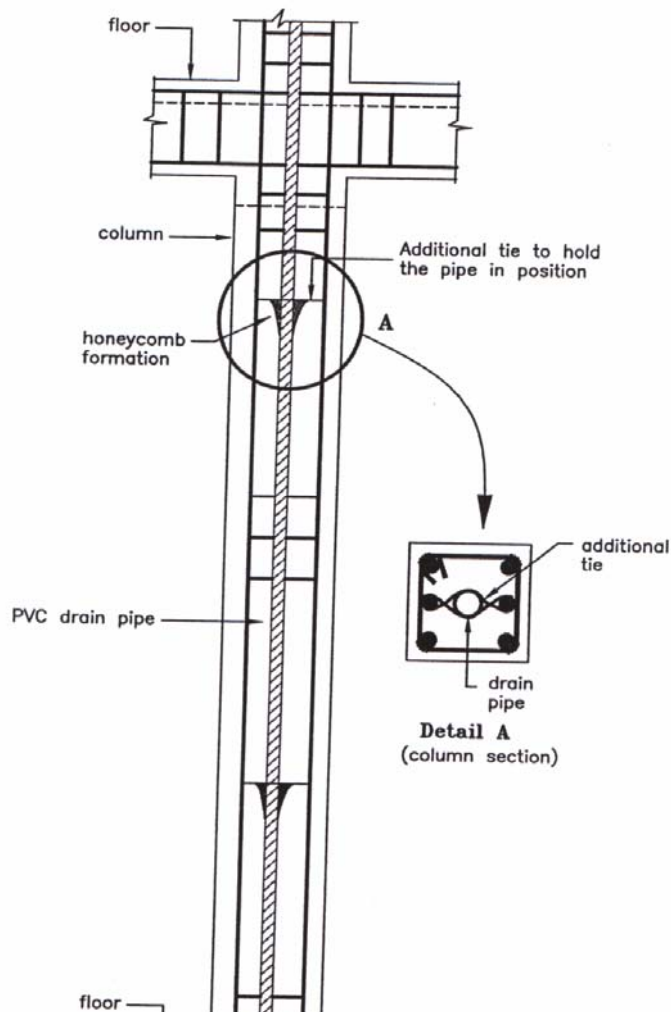

Fig. 2 Formation of Honeycombs Around The Drain Pipe

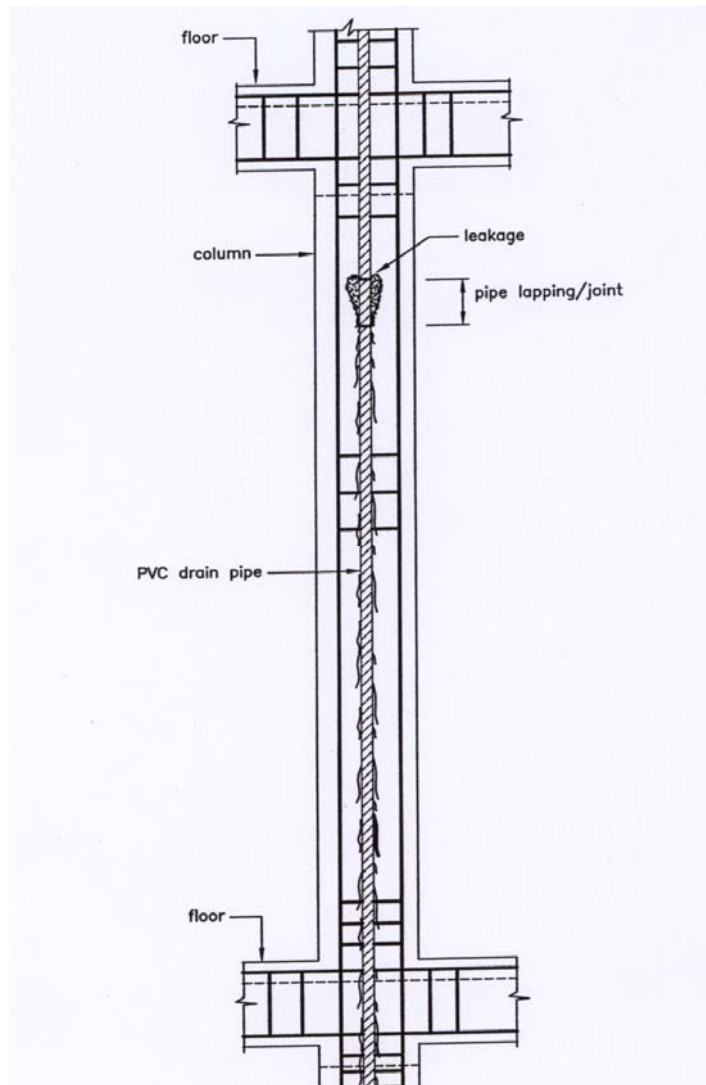

Fig. 3 Leakage In The Lapping parts of The PVC Drain Pipes

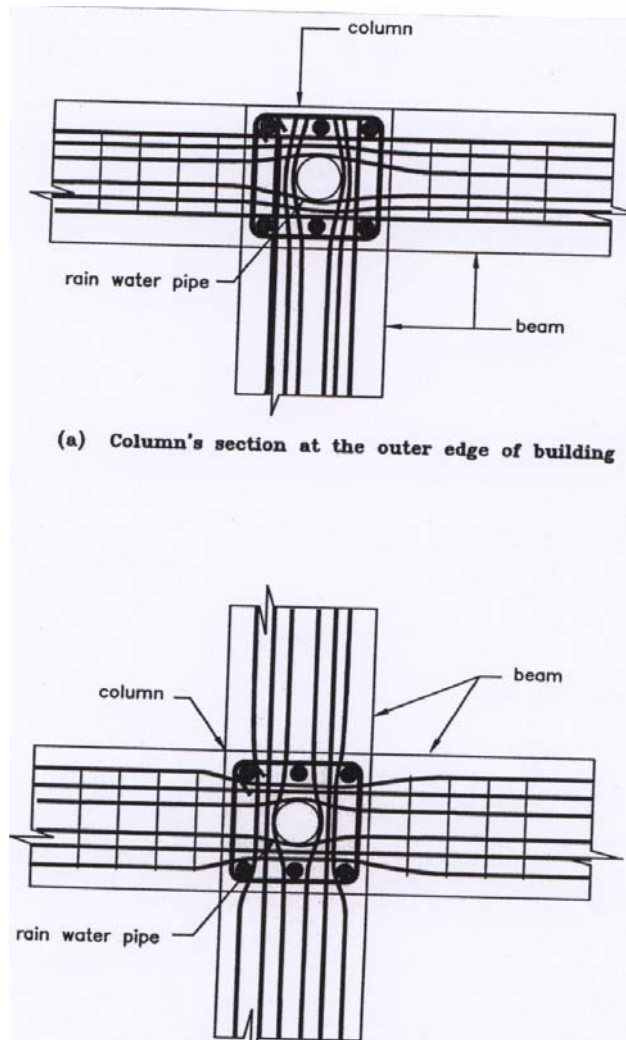

Fig. 4 Congestion and Nonuniformity In Beams Reinforcements At Column's Section Caused By The Presence of Drain Pipe

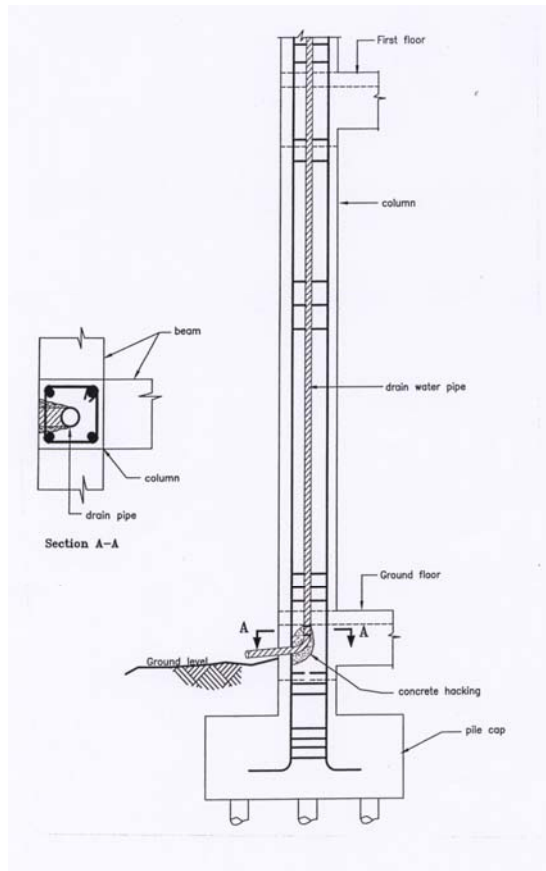

Fig. 5 Elbow Part of The Drain Pipe At The Ground Level

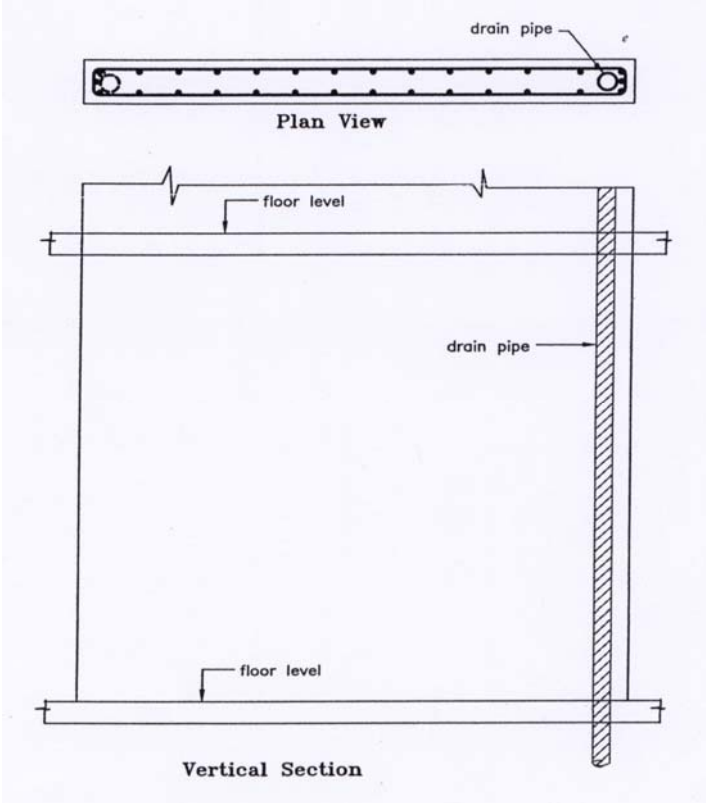

Fig. 6 Drain Pipe Positioned At The Edge of RC Wall

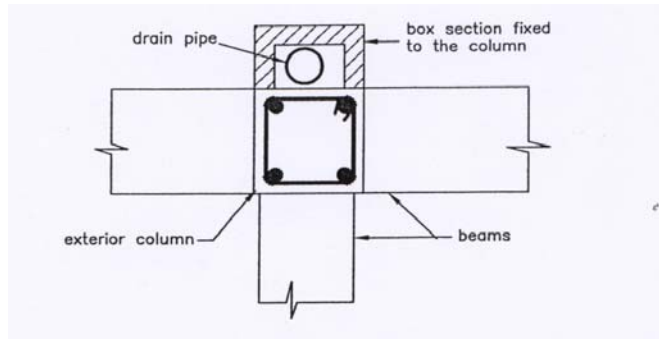
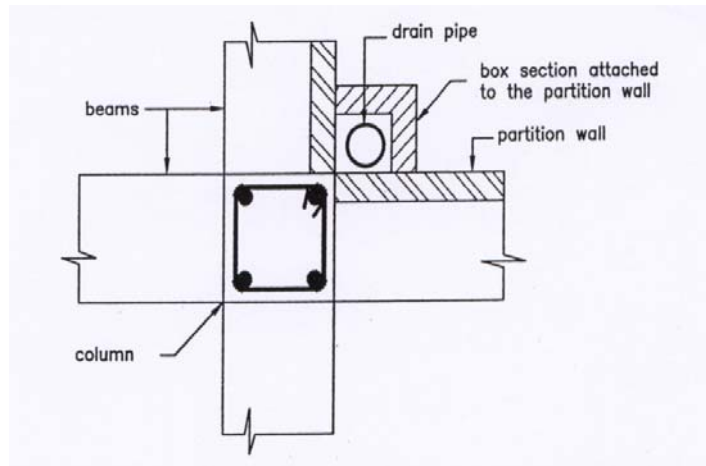

Fig. 7 Rain Water Pipe Hidden in a Hollow Box Section Outside Column's Section (Attached to column)



14 **Fig. 8 Rain Water Pipe Outside Column's Section Passing Through Corner of The Slab Covered In Hollow Box Section**

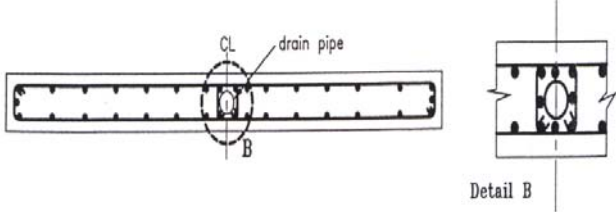

Fig. 9 Plan View of RC Wall Showing The Drain Pipe Positioned At The Centre of The Section of Wall