

UNIVERSITI TEKNOLOGI MALAYSIA

BORANG PENGESAHAN
LAPORAN AKHIR PENYELIDIKAN

TAJUK PROJEK: DEVELOPMENT OF A SOIL EROSION MODELING AND
PREDICTION PACKAGE FOR EIA USING GIS PRIME
MEREDIAN. _____

Saya ____TAHER BIN BUYONG_____
(HURUF BESAR)

Mengaku membenarkan Laporan Akhir Penyelidikan ini disimpan di Perpustakaan
Universiti Teknologi
Malaysia dengan syarat-syarat kegunaan seperti berikut :

1. Laporan Akhir Penyelidikan ini adalah hakmilik Universiti Teknologi Malaysia.
2. Perpustakaan Universiti Teknologi Malaysia dibenarkan membuat salinan untuk tujuan rujukan sahaja.
3. Perpustakaan dibenarkan membuat penjualan salinan Laporan Akhir Penyelidikan ini bagi kategori TIDAK TERHAD.

4. * Sila tandakan (/)

SULIT

(Mengandungi maklumat yang berdarjah keselamatan atau
Kepentingan Malaysia seperti yang termaktub di dalam
AKTA RAHSIA RASMI 1972).

TERHAD

(Mengandungi maklumat TERHAD yang telah ditentukan
oleh Organisasi/badan di mana penyelidikan dijalankan).

TIDAK
TERHAD



TANDATANGAN KETUA PENYELIDIK
Nama & Cop Ketua Penyelidik

Tarikh : 11 October 2004

CATATAN : * Jika Laporan Akhir Penyelidikan ini SULIT atau TERHAD, sila lampirkan surat
daripada pihak berkuasa/organisasi berkenaan dengan menyatakan sekali sebab dan tempoh laporan ini
perlu dikelaskan sebagai SULIT dan TERHAD.

VOT 71593

**DEVELOPMENT OF A SOIL EROSION MODELING
AND PREDICTION PACKAGE FOR ENVIRONMENTAL
IMPACT ASSESSMENT USING GIS PRIME MERIDIAN**

**(PEMBANGUNAN PAKEJ PEMODELAN DAN
PERAMALAN HAKISAN TANAH UNTUK PENILAIAN
KESAN ALAM SEKITAR MENGGUNAKAN PRIME
MERIDIAN GIS)**

**TAHER BUYONG
TANG CHUOON MUN**

**PUSAT PENGURAN PENYELIDIKAN
UNIVERSITI TEKNOLOGI MALAYSIA**

VOT 71593

**DEVELOPMENT OF A SOIL EROSION MODELING
AND PREDICTION PACKAGE FOR ENVIRONMENTAL
IMPACT ASSESSMENT USING GIS PRIME MERIDIAN**

**(PEMBANGUNAN PAKEJ PEMODELAN DAN
PERAMALAN HAKISAN TANAH UNTUK PENILAIAN
KESAN ALAM SEKITAR MENGGUNAKAN PRIME
MERIDIAN GIS)**

**TAHER BUYONG
TANG CHUOON MUN**

**RESEARCH VOTE NO:
71916**

**Jabatan Pentadbiran dan Pembangunan Tanah
Fakulti Kejuruteraan dan Sains Geoinformasi
Universiti Teknologi Malaysia**

2004

ACKNOWLEDGEMENTS

The authors would like to thank the staff of Dataprep-Sysdeco, especially En Kahiruddin Zainodin, Cik Suraya and Mr Alfred Yeap for their kindness cooperation and support for giving us the opportunity to learn and Essential Planning System GIS Prime Meridian System. Technical support and guidance from En Ariff Yaakob, Mr Kevin, Mr David, Cik Siti and En Megat are highly appreciated. We are also grateful to Mr Chan Hoong Kheong for providing assistance in the course of our work.

ABSTRACT

A number of soil erosion models have been developed to predict and characterize the movement of soil. These models provide an understanding of the dynamics of soil and can be used to evaluate the effectiveness of land management practices. Nevertheless, modellers faced some major problems. They are the inability to efficiently handle, manipulate and manage large volumes of model parameters. However, recent developments in Geographic Information Systems (GIS) provide the opportunities and tools to spatially organize and effectively manage data for the modelling. Thus, this research aims to develop an interactive soil erosion modelling and prediction system within a GIS environment. Prime Meridian GIS' Spatial Database Engine by Essential Planning System Pte. Ltd. (EPS), will be the core of the designed system. This system is designed to use the universal soil loss equation and the overlay modelling technique to generate the soil erosion risk map. The goal of developing the system is to provide a spatial decision support tool in environmental impact assessment as required by the Department of Environment, Ministry of Science Technology and Environment.

ABSTRAK

Beberapa model hakisan tanah telah dibina untuk meramal and mencirikan pergerakan tanah. Model-model ini memberikan suatu pemahaman tentang dinamik tanah dan boleh digunakan untuk menilai tahap efektifnya sesuatu aktiviti pengurusan tanah itu. Namun demikian, ahli permodelan menghadapi beberapa masalah yang utama. Di antaranya adalah kurangnya kebolehan untuk mengawal, manipulasi dan mengurus isipadu model parameter yang banyak. Walaubagaimanapun, perkembangan terkini di dalam Sistem Maklumat Geografi (*Geographic Information System*) memberikan peluang dan bertindak sebagai suatu peralatan untuk menyusun data spatial dan mengurus data permodelan. Maka, kajian ini adalah bertujuan untuk mewujudkan suatu sistem ramalan dan permodelan hakisan tanah di dalam alam sistem maklumat geografi (*GIS environment*). Sistem yang direka ini akan menggunakan Injin Pangkalan Data Spatial (*Spatial Database Engine*) GIS Prime Meridian yang dicipta oleh Essential Planning System (EPS). Sistem ini akan menggunakan Persamaan Kehilangan Tanah Sejagat (*Universal Soil Loss Equation*) dan Teknik Pertindihan Model (*Overlay Modelling Technique*) untuk menghasilkan peta hakisan tanah (*soil erosion risk map*). Matlamat menghasilkan sistem ini adalah untuk mewujudkan suatu alat sokongan keputusan spatial bagi penilaian alam sekitar seperti mana yang diperlukan oleh Jabatan Alam Sekitar, Kementerian Sains Teknologi dan Alam Sekitar.

TABLE OF CONTENTS

CHAPTER	TOPIC	PAGE
	TITLE PAGE	
	DEDICATIONS	ii
	ACKNOWLEDGEMENTS	iii
	ABSTRACT	iv
	ABSTRAK	v
	TABLE OF CONTENTS	vi
	LIST OF FIGURES	ix
	LIST OF TABLES	xi
	LIST OF APPENDICES	xii
1.0	BACKGROUND	
1.1	Introduction	1
1.2	Problem Statement	2
1.3	Study Area	2
1.4	Research Objectives	4
1.5	The Scope of The Study	4
1.6	Overview of Previous Studies	6
1.7	Methodology	9
2.0	THEORIES RELATED TO THE SOFTWARE DEVELOPMENT	
2.1	Universal Soil Loss Equation	12
2.1.1	The Rainfall Factor (R Factor)	14
2.1.2	The Soil Erodibility Factor (K Factor)	14
2.1.3	The Length of Slope Factor (LS Factor)	16
2.1.4	The Vegetation Cover Factor (P Factor)	17
2.1.5	The Conservation Practice Factor (C Factor)	18
2.2	Overlay Modelling Technique	19

2.2.1	Overlay Operations	19
2.2.1.1	The Vector-Based Overlay	19
2.2.1.2	The Raster-Based Overlay	20
3.0 ESSENTIAL PLANNING SYSTEMS PRIME MERIDIAN		
3.1	Overview	22
3.2	Components of Prime Meridian	23
3.2.1	Spatial Database	23
3.2.1.1	Spatial Database Component	24
3.2.1.2	Attribute Database Component	24
3.2.2	Spatial Database Builder	25
3.2.3	Spatial Access Engine	25
3.2.4	High Spatial Query Language	26
3.2.5	Application Program Interfaces	26
3.3	Benefits of Prime Meridian	27
3.3.1	Seamless Integration	27
3.3.2	Modularity	28
3.3.3	Compliance	29
4.0 THE PROTOTYPE SOIL EROSION AND MODELLING SYSTEM		
4.1	Overview of Eromap	30
4.2	System Development	30
4.2.1	System Design Flow	31
4.2.2	Application Flow	32
4.2.3	System's Directory Structure	33
4.2.3.1	APP Directory	33
4.2.3.2	SAE Directory	34
4.2.3.3	Font Directory	34
4.2.3.4	SDB Directory	34
4.2.3.5	Exchange Directory	34
4.2.3.6	VBXDLL	35
4.2.3.7	Userdata Directory	35

4.3	Program Organization	35
4.3.1	Module 1 : Layer Interrogator	37
4.3.2	Module 2 : Database Builder	40
4.3.3	Module 3 : Erosion Analyzer	41
4.4	Software Evaluation	43
5.0 THE RESULTS AND ANALYSIS		
5.1	Introduction	52
5.2	Efficiency and Reliability of Eromap	53
5.3	The Performance of Eromap	54
5.4	The Presentation Capabilities of Eromap	55
5.5	Limitations of Eromap	55
5.5.1	Separation of The LS Factor	56
5.5.2	Increment of The Display Resolution	57
6.0 REVIEWS, CONCLUSION AND RECOMMENDATIONS		58
REFERENCES		60
APPENDICES		62

LIST OF FIGURES

FIGURE	TITLE	PAGE
1.1	Map showing the location of the study area	3
1.2	Figure depicting the scope of work	5
1.3	Model of the software system	10
2.1	Calculation of the soil erodibility factor	15
2.3	Vector-based overlay operations	20
2.4	Raster-based overlay operations	21
3.1	Illustration of tiled versus seamless coverage	28
4.1	System design work flow	31
4.2	Application flow	32
4.3	Directory hierarchy of the spatial data manager	33
4.4	An interactive modelling environment	36
4.5	Organization chart of module 1	38
4.6	Pseudocodes of module 1	39
4.7	Organization chart of module 2	40
4.8	Organization chart of module 3	41
4.9	Pseudocodes of module 3	42
4.10	Window display of Eromap	43
4.11	Password form	44
4.12	System Interrogator form	44
4.13	Database builder	45
4.14	Database builder' menu bar	45

4.15	Delineation of polygon	46
4.16	Data cleaning	46
4.17	Assigning values to respective layers	47
4.18	Password clearance	47
4.19	Display of map window	48
4.20	Display of R Factor	48
4.21	Display of LS Factor	49
4.22	Display of K Factor	49
4.23	Display of P Factor	50
4.24	Display of C Factor	50
4.25	Display of Soil Erosion Risk Map	51

LIST OF TABLES

TABLE	TITLE	PAGE
2.1	Combined LS Factor (Slope Length and Steepness) for The Soil Erosion Equation	17
2.2	The P Factor	18

LIST OF APPENDICES

APPENDIX	TITLE	PAGE
1	Rain Erosivity Factor (R)	63
2	Soil Erodibility Factor (K)	64
3	Length of Slope Factor (LS)	65
4	Soil Erosion Risk Map	66
5	Eromap Prototype Source Code	67

CHAPTER ONE

BACKGROUND

1.1 Introduction

Environmental Impact Assessment (EIA) is a process to evaluate, predict and to report both the positive and negative effects of a development project. It also strives and perseveres to find ways to deal with the environmental problems. Needless to say that manual analysis of the raw data for EIA is extremely tedious and time consuming especially in analysis which involves mathematical modelling and cartographic map presentation. Consequently, the mobilizations of developmental projects will be hampered. By utilizing GIS as a tool for analysis, it is hoped that EIA analysis will be faster, efficient and more systematic.

As most EIA projects require erosion analysis, thus, the development of a Soil Erosion Modelling and Prediction Package using Prime Meridian Geographic Information System's Spatial Database Engine is explored in this research project. The concept of modelling and prediction of soil loss at a regional scale is based on the widely known Universal Soil Loss Equation (USLE). The results of the experiment will be presented at the end of this study in a form of soil erosion risk map. This erosion analysis system will definitely improve the proficiency of EIA analysis and more importantly in generating the soil erosion risk map with minimum cost and time.

1.2 Problem Statement

Under the Environmental Quality Act, 1974 (Amendment) 1985, most developments require environmental impact assessments to be conducted and have the results presented in the form of reports. Handling environmental data manually is almost impossible, what more if analysis is needed. Thus, in the area of soil erosion assessment and analysis, there exists a few problems:

- A demand for the generation of soil erosion risk maps for Environmental Impact Assessment in view of the influx of the Malaysia's development.
- The need for soil erosion risk maps to be produced in a very fast and yet economic manner without losing its information's quality.
- Manually assessing and analyzing the environmental data for the production of the erosion risk map is not feasible.

Therefore, a GIS Soil Erosion Modelling and Prediction will certainly be able to solve the problems above.

1.3 Study Area

Langkawi Island, Kedah Darulaman, situated at approximately 180000.000mE to 225000.000mE and 675000.000mN to 720000.000mN in the Rectified Skew Orthomorphic coordinate system has been selected as the sample test site for experimenting this prototype erosion analysis system (see Figure 1.1). This island was chosen in view of the availability of the parametric data needed by the modelling equations.

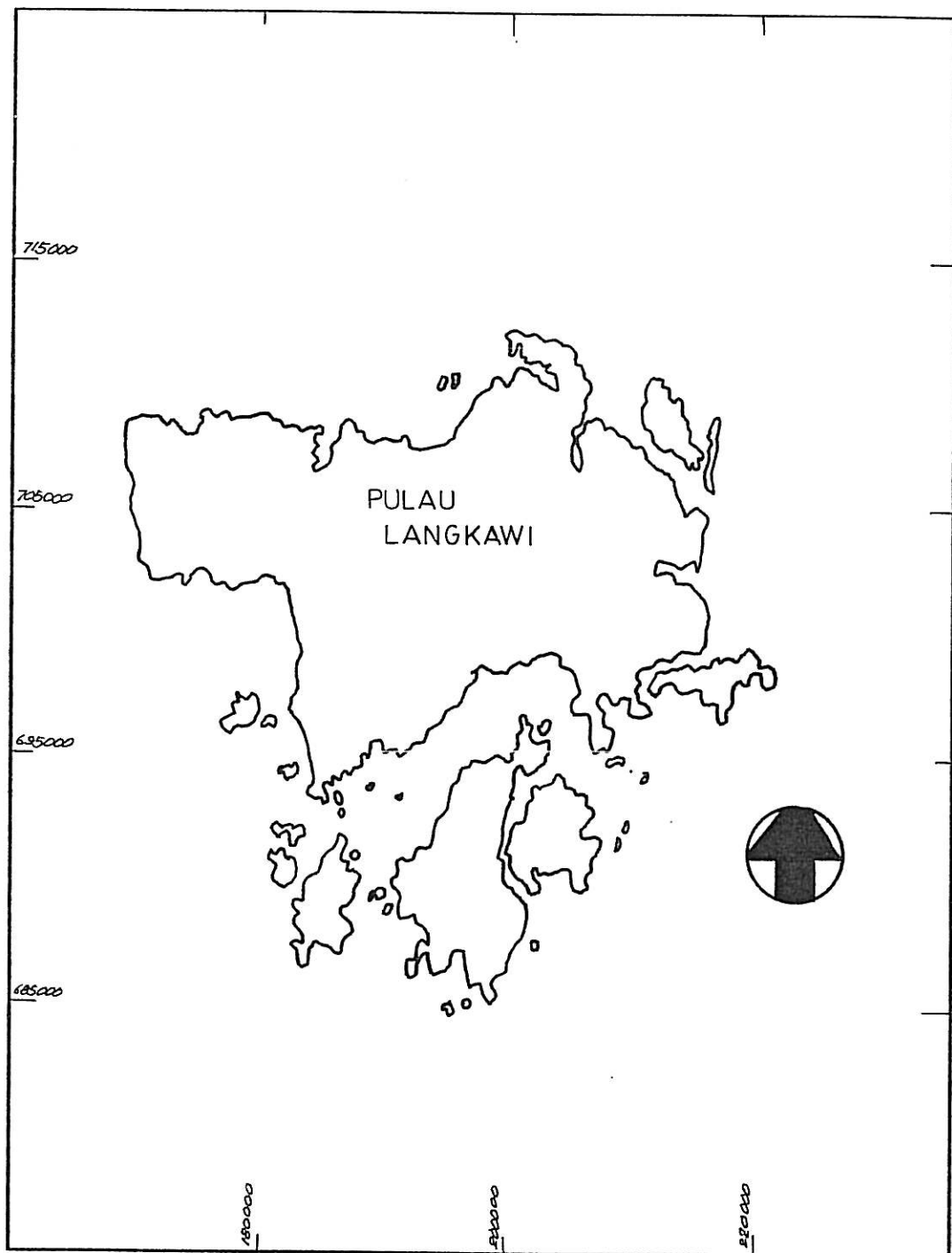

Figure 1.1
Map showing location of the study area.

1.4 Research Objectives

The main objectives of this research are :

- To develop an application software for soil erosion loss analysis using Prime Meridian GIS' Spatial Database Engine (SDE).
- To generate a Soil Erosion Risk Map using the prototype software.

1.5 The Scope of The Study

The scope of the research encompasses Visual Basic (VB) programming procedures to develop a soil erosion modelling and prediction software using the EPS Prime Meridian's Spatial Database Engine. Visual Basic programming language will interface with the Spatial Structured Query language (S²QL) of the SDE to generate the soil erosion risk maps through the principle of the Universal Soil Loss Equation. Figure 1.2 illustrates the scope of the work involved.

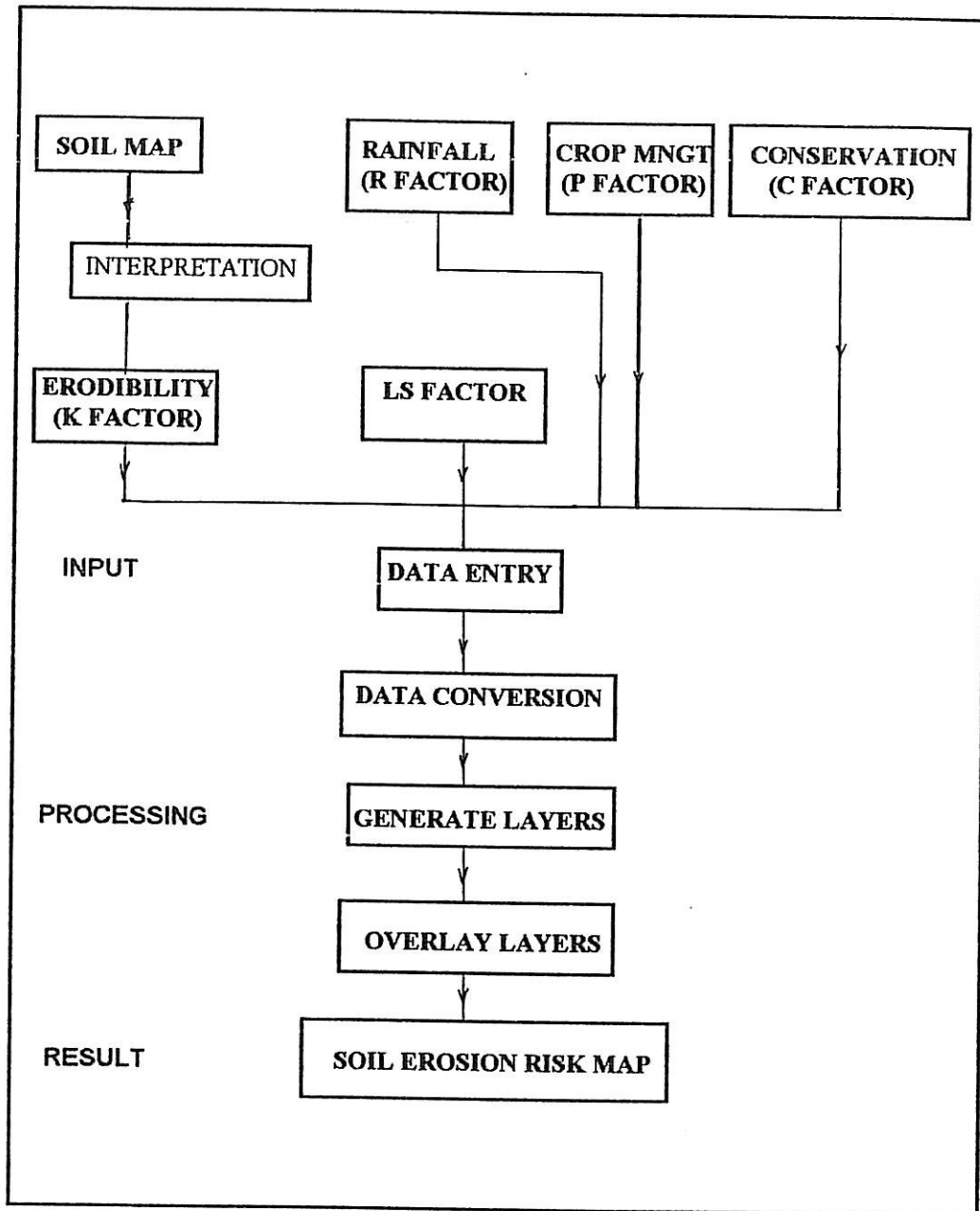

Figure 1.2
Figure depicting the scope of work

1.6 Overview of Previous Studies

The threat from soil erosions and the importance of erosion awareness were highlighted by Olson (1981). Thus, there is a need for erosion modelling to assess and to understand the impact of erosion towards the soil. Modelling of the dynamics of soil leads to the conception of a number of modelling equations.

Morgan (1986) conveyed the details of a few techniques used to enable soil erosion to be assessed. Three methods of soil erosion modelling are introduced here. They are:

- **The Universal Soil Loss Equation**

This method was introduced by Wischmeier and Smith in 1962. This soil loss prediction method needs five parameters before results could be produced. The mathematical model for this method is described as :

$$E = R.L.S.K.C.P$$

with the following notation

R : Rainfall Erosivity Index

K : Soil Erodibility Index

L : Length of Slope

S : Slope Steepness

C : Conservation Practice

P : Crop Management

This model is the most common model used in many regions of the world.

• **The Stehlik Method**

This method was developed by Stehlik in 1975 for predicting the annual rate of soil erosion in Czechoslovakia. It uses the equation :

$$X = D.G.P.L.S.O$$

where the notation of each factor represents:

- D :** The climatic factor
- G :** The petrologic factor and assesses the rock type according to the permeability of its weathered debris.
- P :** Erodibility of the soil based on the percentage of particles smaller than 0.1mm in size and the organic content.
- S:** Slope steepness ($S = 0.24 + 0.106s + 0.0028s^2$) where s is the slope in percent.
- L:** Slope length factor.
- O:** Vegetation factor.

This equation is most sensitive to changes in slope steepness.

- **The Morgan and Finney Method**

This is also another model developed to predict annual soil loss from field-sized areas to hill slopes. The founders of this equation were Morgan and Finney in 1984. This model separates the soil erosion process into water phase and sediment phase. It requires 15 input parameters and six operating functions. Due to the complexity of the equation, the mathematical model of this method is not described here. For further information, please refer to *The Fundamental of Soil Science* by Foth, 1984.

The method of predicting soil erosion and sediment loss using the Universal Soil Loss Equation in a computer environment was presented in the work of Foth (1984), Miller and Donahue (1990). A detailed methodology to calculate the values for each of the parameters employed by the Universal Soil Loss Equation was also discussed in length.

With the existence of soil loss mathematical models, Chakroun (1992) proposed a methodology for mapping and monitoring soil loss at a regional scale using GIS systems. The concept used was based on interfacing a hydrological model to a modified version of the widely known Universal Soil Loss Equation and the product of the research was a soil erosion loss map.

With the soil risk map or rather soil loss map, interpretation of the behaviour of soil movement can be assessed. Bergsma (1983) played a vital role in the area of soil dynamics by stressing the importance and the personification of soil risk maps. He described that there were three major groups of erosion maps. The first group showed

the present erosion features and the indication of the on-going erosion processes. The second group indicated past erosion and the third group identified the erosion hazard factors. With the risk maps produced, how the past and the present data (risk maps) could contribute to the erosion hazard surveys which were necessary for conservation planning can be shown.

As for conservation planning, a literature about an interactive water quality modelling system developed within the GIS environment was presented by Liao (1994). As soil erosion is one of the factors affecting water quality, thus modelling of soil erosion was discussed in this paper too. Finally, a simulation of the soil erosion rates in an agriculture landscape based on the Universal Soil Loss Equation was done.

1.7 Methodology

Firstly, the mathematical model used for the analysis is the Universal Soil Loss Equation (USLE) of Wischmeier and Smith (1965) is used for the analysis. In the software, the parameters are represented in the form of digital layers.

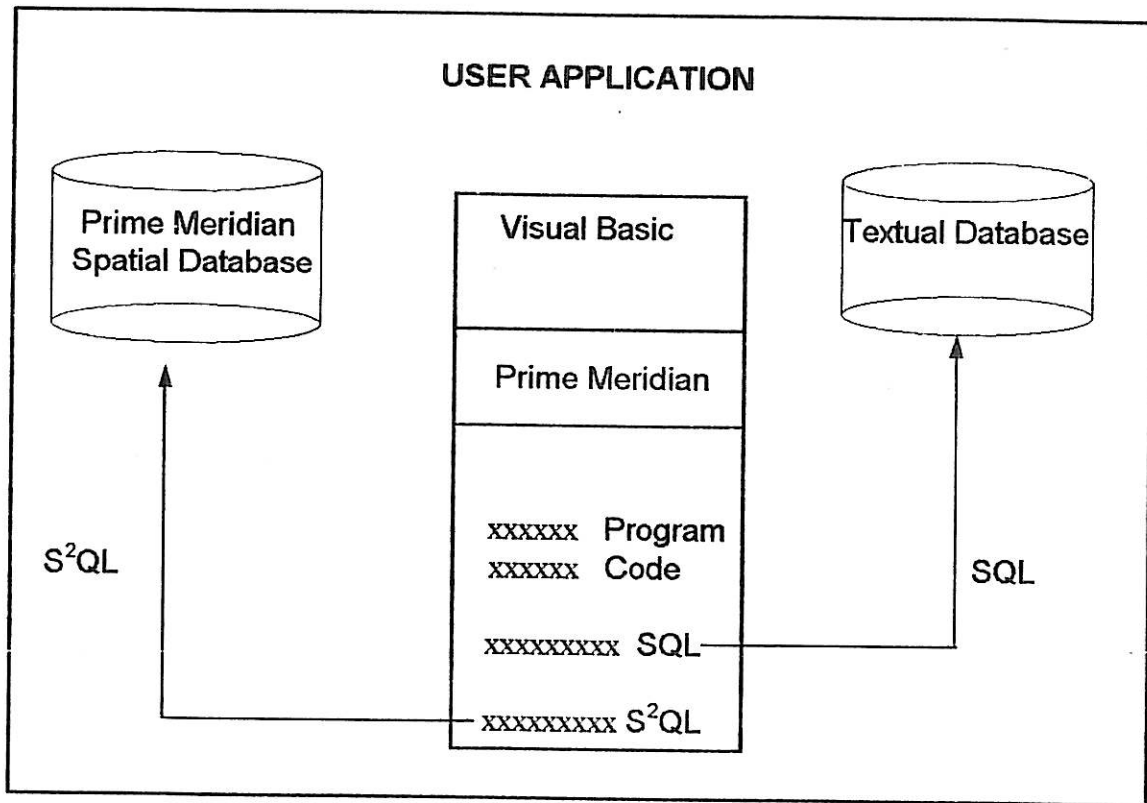

Figure 1.3
Model of the software system

Secondly, a software for soil erosion modelling and prediction will be developed through the Prime Meridian GIS' Spatial Database Engine using Visual Basic as the programming language. Figure 1.3 shows the schematic diagram depicting the software system.

Thirdly, trial runs using the developed application software will be conducted on a sample test site. Langkawi Island has been selected for this test. The data for the respective layers (parameters) will be obtained from various sources.

Once all the layers have been integrated into the developed GIS application software, the various factors represented by the layers are multiplied according to the USLE expression. The overlay modelling technique will be used in this multiplication before the cartographic presentation of the erosion risk map.

CHAPTER TWO

THEORIES RELATED TO THE SOFTWARE DEVELOPMENT

2.1 Universal Soil Loss Equation

In 1965, the Universal Soil Loss Equation (USLE) was first proposed and used for estimating sheet and rill erosion sediment losses from cultivated fields in the eastern flank of the Rocky Mountains in the United States of America. Besides that, this equation can also enable:-

- The prediction of average annual soil loss from a given field slope under specified land use and management conditions.
- The guidance to the selection of conservation practices.
- The estimation of the reduction of soil loss attainable from various changes in farm management, cropping systems and cultural practices.
- The provision of localized data on soil erosion rates to conservation agencies and resource managers when discussing erosion control (conservation) plans with farmers.

The equation has since been adapted for use in other cultivated areas of USA, in Europe, in tropical Hawaii, Western Africa and Asia with little or no modifications to the equation. (Wishmeier *et al*, 1982)

The expected soil loss is determined from the product of five factors : rainfall (R factor), erodibility of the selected soil (K factor), the length (L factor), steepness of slope (S factor), the types of Crop (P factor) and Conservation practices (C factor).

Wishmeier and Smith (1978) defined the USLE as :

$$E = R.L.S.K.C.P$$

E : Erosion soil loss in tons per acre per year

R : Rainfall erosivity index

L : Length of slope

S : Steepness of slope

K : Soil erodibility factor

C : Conservation practice factor

P : Crop management factor

The many possible numerical values for each factor require extensive knowledge and preparation. A practicing conservationist normally works in a small area, maybe a county and often will need only one or two rainfall factors (R), values for a few soils (K), a few cropping (vegetative) systems (P), the LS factor and the conservation practice (C) factor.

2.1.1 The Rainfall Factor (R Factor)

The rainfall factor (R) is a product of the kinetic energy (falling force) of a small rainfall multiplies with its maximum 30-minute period intensity of the fall. In countries where there is snow-melt in the area of precipitation pattern, the symbol R_s is often used as the snow-melt contribution and added to rainfall to equal total R. Obviously, fluctuations in duration and intensities of storms from year to year complicate getting the “average” R value for any location.

2.1.2 The Soil Erodibility Factor (K Factor)

Soil erodibility (K) is the ease with which a soil can be eroded. Values are ranged from 1.0 (most easily eroded) to 0.01 (almost non-erosive). Soil high in silt and very fine sand are more easily eroded than other soils. Organic matter, larger structural aggregates, and rapid soil permeability will reduce the soil K factor. Figure 2.1 illustrates an example of the calculation of the K factor.

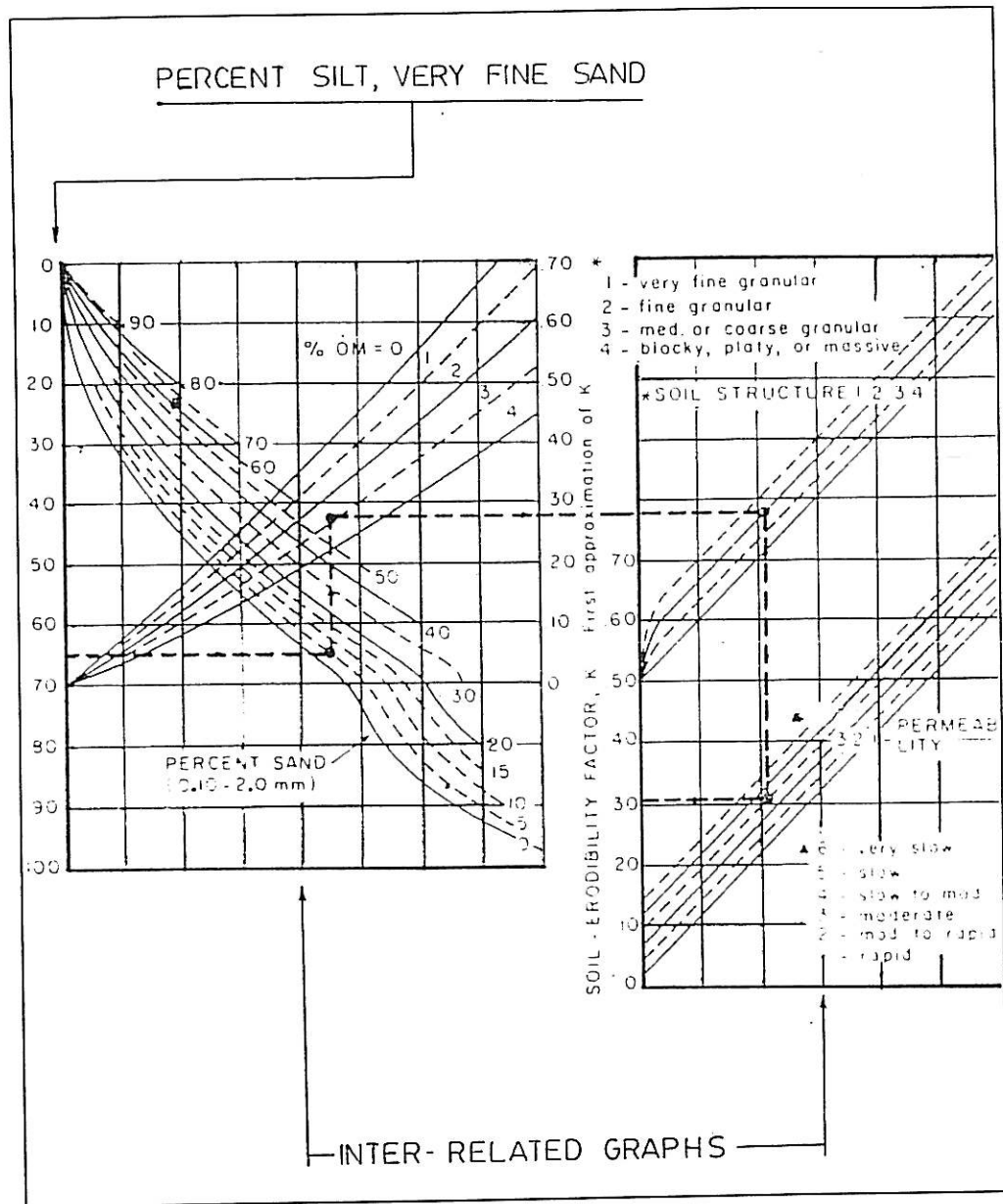

The soil erodibility factor (K) is estimated from four soil properties: texture, organic matter content, soil structure and permeability data. When compared with measured K values, about 95 percent of tested soils varied less than 0.04 K value from calculated values by this technique. To calculate a soil K value, in this example of a soil with 65 percent silt plus very fine sand, 5 percent other sands, 2.8 percent organic matter, structure 2 and permeability 4, follow the dashed line on the graph starting at the left at 65 percent (silt + very fine sand). The obtained K value is 0.31.

Figure 2.1
Calculation of the Soil Erodibility Factor (K)

2.1.3 The Length of Slope Factor (LS Factor)

The length-slope value (LS) is the ratio of soil loss from the slope in question to the soil loss from the reference, which is a slope 22.1 metres (72.6 feet) long and a uniform 9 percent grade. The reference slope has an LS factor of 1.00. The LS factor could be determined through the following equation by McGuire (1995):

$$LS = (L/22)^{0.5} \times (0.065 + 0.045S + 0.0065S^2)$$

where L is the length of the slope in metres and S is the steepness in percent.

Longer slopes increase erosion because water accumulates and increases in speed, collecting more cutting sediment and doing proportionally more damages. Doubling slope steepness (percentage grade) will double the erosion rate while on long slopes it may triple the erosion. Doubling slope length (with the same grade) increases erosion from about 20-40 percent. Convex slopes (dome-shaped) have more erosion than indicated by calculations using the average slopes concave (saucer-shaped) slopes have less erosion than calculations using average slopes. Changes in plant cover between the comparative slopes complicate these calculations and recognition must be made from the differences. Table 2.1 shows the combined LS factor for the soil erosion equation when compared to the standard reference of a slope 72.6 feet long with steepness of 9 percent.

Table 2.1 : Combined LS factor (slope length and steepness) for the soil erosion equation when compared to the standard reference of a slope 72.6 ft. long with steepness of 9 percent.

Slope %	Slope Length (ft)							
	25	50	100	200	400	600	800	1000
0.5	0.073	0.083	0.096	0.110	0.126	0.137	0.145	0.152
2.0	0.13	0.16	0.20	0.25	0.31	0.35	0.38	0.40
4.0	0.23	0.30	0.40	0.53	0.70	0.82	0.92	1.01
8.0	0.50	0.70	0.99	1.41	1.98	2.43	2.81	3.14
12.0	0.90	1.28	1.80	2.65	3.61	4.42	5.11	5.71
16.0	1.42	2.01	2.84	4.01	5.68	6.95	8.03	8.98
20.0	2.04	2.88	4.08	5.77	8.16	10.0	11.5	12.9

(Source : Wischmeir, 1965)

2.1.4 The Vegetation Cover Factor (P Factor)

The vegetation cover factor or better known as crop management factor considers the type and density of vegetation cover on the soil and all related management practices, such as time between operations (delay in planting after plowing and so forth). The C factor is very complicated because of the wide range of possibilities in cover material, management and the manner in which the crop residues can be left soil. A case to be kept in mind is that if a region comprises of several areas needs evaluation, then the C factor can be dropped as it is a constant in the USLE equation. (Olson, 1981)

2.1.5 Conservation Practice Factor (C Factor)

The conservation practice factor (C) recognizes the influence of contour planting, strip cropping, terracing and combinations. Table 2.2 lists several of these practices and their effects on erosion. The total benefit of terracing is not evident in the table because, after terracing, each terrace is treated as a separate slope less steep than the original slope and the terrace width is used as the slope length. These factors are put into the LS factor. The greatest erosion control by optimum choice of practice would be on level terraces (zero slope) having excellent protective cover on connecting slopes.

Table 2.2 : The P Factor, which is the ratio of the erosion resultant from the practice described to that which occur with up-and-down-slope cultivation.

Vegetative Condition	P Value
1-2 % slope, contoured, in 400 ft lengths	0.60
3-5 % slope, contoured, in 300 ft lengths	0.50
6-8 % slope, contoured, in 200 ft lengths	0.50
9-12 % slope, contoured, in 120 ft lengths	0.60
21-25 % slope, contoured, in 50 ft lengths	0.90
1-2 % slope, contour strip cropping, 130 ft strip width, 800 ft slope length (along the direction of the strip)	0.60
6-8 % slope, contour strip cropping, 100 ft strip width, 400 ft slope length	0.50
13-16 % slope, contour strip cropping, 80 ft strip width, 160 ft slope length	0.70
21-25 % slope, contour strip cropping, 50 ft strip width, 100 ft slope length	0.90

(Source: Wischmeier, 1965)

2.2 Overlay Modelling Technique

The power of GIS is her ability to combine data from many sources using different scales, projections and data models are her major strengths. An overlay operation can be characterized as “light -table gymnastics”. These involved the creation of a new map on which the value assigned to every point, or a set of points, is a function of the independent values associated with that location on two or more existing overlays. (Berry,1993)

2.2.1 Overlay Operations

Arithmetic and logical overlay operations are part and parcel of all GIS systems. Arithmetic overlay includes operations such as addition, subtraction, division and multiplication of each value in a data layer by the value in the corresponding location in a second data layer. A logical overlay involves finding those area where a specified set of condition occurs or do not occur together. All in all, there are two types of overlays, namely the vector-based and the raster-based overlays.

2.2.1.1 The Vector-Based Overlay

Figure 2.3 gives a simple example for two categorical data layers with vector-based structures. The data layers here are represented in polygons. These polygons differ from each other in size and shape. The attributes of the polygons are stored in a separate attribute table. Overlaying the two polygons will create a new polygon with a new set of attribute value.

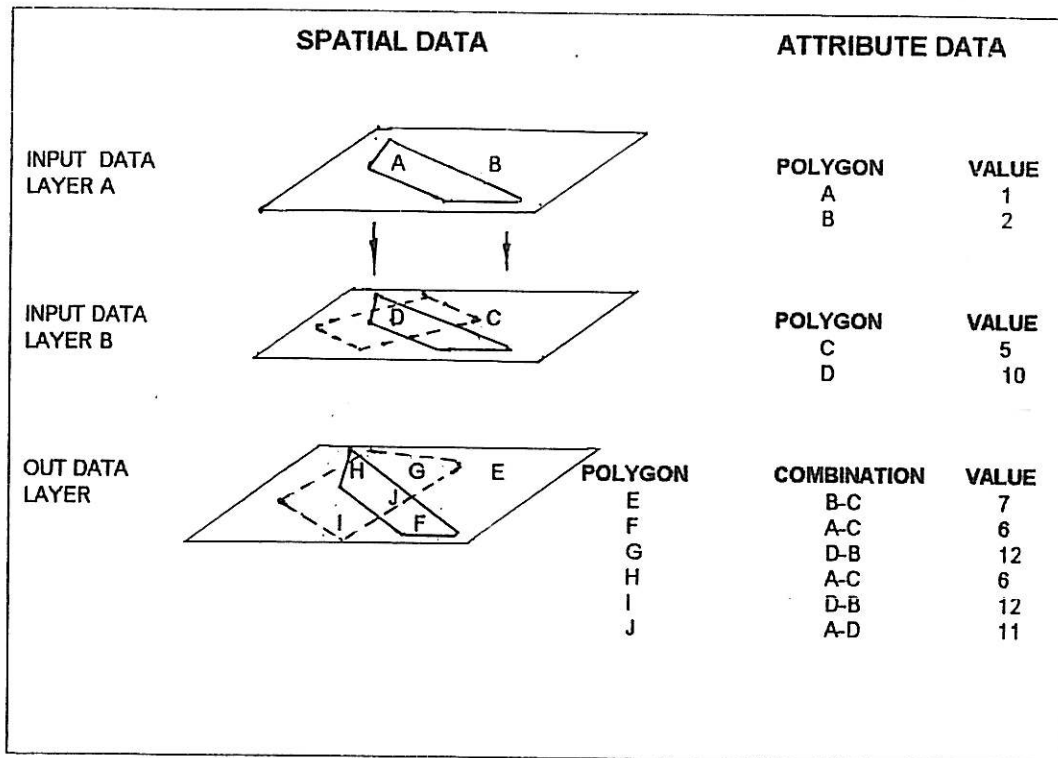

Figure 2.3
Vector-based overlay operations

2.2.1.2 Raster-Based Overlay

Basically, in the raster-based overlay, data files consist of an ordered list of values. The spatial location of these values are determined by the position of the value within the file itself. Therefore, the overlay process between two files involves retrieving and registering the data from one layer to another data layer of interest. There is no need to calculate the intersections of boundaries or make any modifications to the boundary feature because each spatial element is a single cell with a standard size. Figure 2.4 illustrates the raster-based overlay operations.

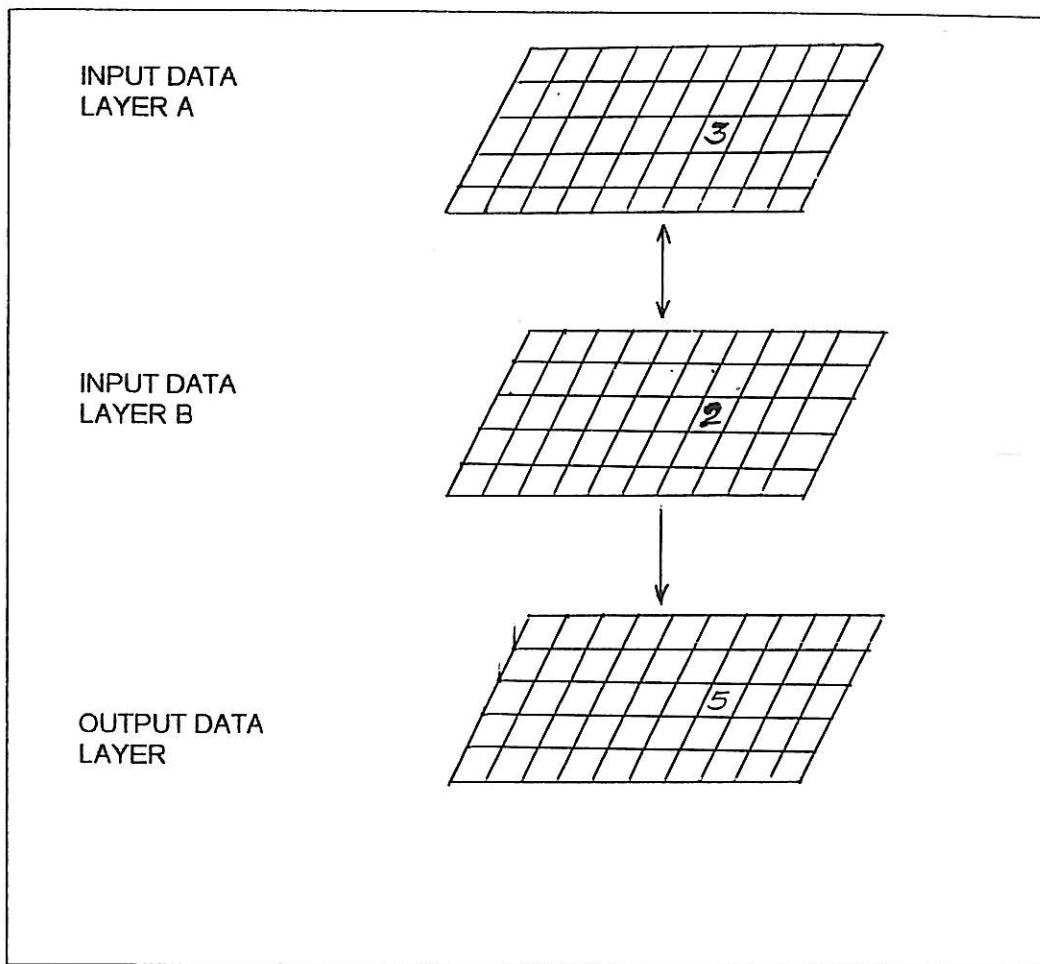

Figure 2.4
Raster-based overlay operation

CHAPTER THREE

ESSENTIAL PLANNING SYSTEMS PRIME MERIDIAN

3.1 Overview

EPS/Prime Meridian from Essential Planning Systems Ltd. Canada is a powerful spatial database comprising a spatial database builder, spatial database engine and a comprehensive set of modular API. It brings a new generation of benefits to the traditional geographic information applications (GIAs) and as well as to an emerging universe of commercial applications.

EPS/Prime Meridian frees the application developer from purchasing and customizing standard GIS or from constructing proprietary technology. With EPS/Prime Meridian, systems development team can seamlessly integrate the benefits of sophisticated spatial data analysis in any geographical application rapidly, easily and economically. This results in fast, flexible embedding of the appropriate GIS functionality optimal to any application. Thus, time and cost can be reduced. EPS/Prime Meridian can be either in a client/server, standalone or distributed environment.

3.2 Components of Prime Meridian

EPS/Prime Meridian has five main components. They include:

- a spatial database and its associated linkages to user-selected third party attribute databases.
- a spatial database builder that gives application developers a robust full-featured facility for the design, construction, maintenance and analysis of the spatial database.
- an access engine that, via a high level query language, implements a powerful and flexible gateway to the spatial database.
- a high-level spatial standard query language (S²QL), modelled on industry-standard SQL that embeds full-function GIS in the target application.
- a comprehensive suite of APIs that, for mission-critical application requiring extremely compact code, enable direct access to the spatial database.

3.2.1 Spatial Database

EPS/Prime Meridian geographic information system database consists of two primary database components, namely the spatial and the attribute component.

3.2.1.1 Spatial Database Component

The spatial database component of EPS/Prime Meridian stores a collection of spatial data systematically organized into discrete and logically related sets. This structure helps users to make sense out of the spatial data and provides a framework for spatial database operations such as terrain modelling or map analysis.

This system is a horizontal seamless and fully contiguous. Due to the advanced algorithms for indexing spatial data, there exists no artificial partitions such as tiles, map sheets or facets to hamper a realistic presentation of the real world. The primary spatial elements such as line, arc, point and text are stored within the spatial structure and are registered to a common coordinate system which facilitates comparison of spatial data from different sources.

3.2.1.2 Attribute Database Component

As for the attribute database component, EPS/Prime Meridian require neither user or the developer to store attribute data in the spatial database. Rather, it integrates spatial data and relationships with attribute data stored separately in a third-party database. Oracle, Dbase, Excel and Access are examples of third-party databases. Close coupling by powerful, transparent and dynamic links preserves performance and in fact enhance portability.

3.2.2 Spatial Database Builder

The spatial database builder (SDB) in EPS/Prime Meridian is a full-featured GIS. The database architect or designer is provided with a complete set of tools to design, construct, load, maintain and analyze the spatial database in terms of features, themes and maps.

The SDB also supports the creation and management of relationships and linkages with the attribute database. It grants the spatial database developer to digitize, input, view and draw maps. These tools for topological creation offer exceptional features such as automatic error detection and correction within user-defined tolerances. Design and construction of the attribute database component is simplified through familiar functionality within the third-party database itself.

3.2.3 Spatial Access Engine

The spatial access engine which is the key module in the EPS/Prime Meridian system is dedicated to: managing database traffic, performing high order graphics and spatial analysis, handling raster/vector intermodality and map production. It processes the S²QL commands and delivers access to the database for the application programmer. Via the access engine, application developers can access within their own application, a full range of GIS functionality. The engine and its operation are totally transparent to the application end-user.

3.2.4 High Spatial Query Language

To facilitate access to the spatial database from the application programs, EPS has developed a high-level spatial standard query language, S²QL. These spatial query commands let application builders - in the development environment of their choice - embed any level of GIS functionality desired in their application. The access engine then simply processes these S²QL calls to the spatial database. To ensure optimal performance and function, the engine supports powerful baseline S²QL as internal calls. An additional, extensive library of external calls can be made directly and transparently via the engine.

3.2.3 Application Program Interfaces (APIs)

The spatial access engine in EPS/Prime Meridian achieves a high level of GIS, spatial mapping, spatial database functionality and flexibility. In addition to that, a comprehensive state-of-art application program interfaces permit advanced developers to code their own external executable S²QL commands. EPS/Prime Meridian API's are especially valuable for vastly simplifying the fulfillment of unusual GIS needs, development within extremely high performance mission-critical environments, or the writing of sophisticated speciality applications such as custom spatial data translators. A measure of the flexibility and power of this suite is evidenced in the fact that EPS used these APIs to code EPS/Prime Meridian itself.

3.3 Benefits of Prime Meridian

There are a number of benefits using this system. They are:

- Seamless integration
- Modularity
- Compliance

3.3.1 Seamless Integration

The spatial database provides a horizontal “seamless” coverage, as it contains no arbitrary partitioning according to map sheet or tile boundaries. A horizontal seamless coverage is an accurate representation of the real world. Therefore, there exists no discontinuous features at arbitrary boundaries and all features can be stored as an unbroken series of coordinates. In addition to that, topological relationships can be maintained across a complete mapping or management area. The spatial extents of a Prime Meridian database can cover an entire area conventionally covered by several map sheets. Figure 3.1 shows that a single line can be represented both a waterway and a municipal boundary; only one set of coordinates are actually stored in the database. Thus, this allows the normalization of spatial data and avoids data duplication.

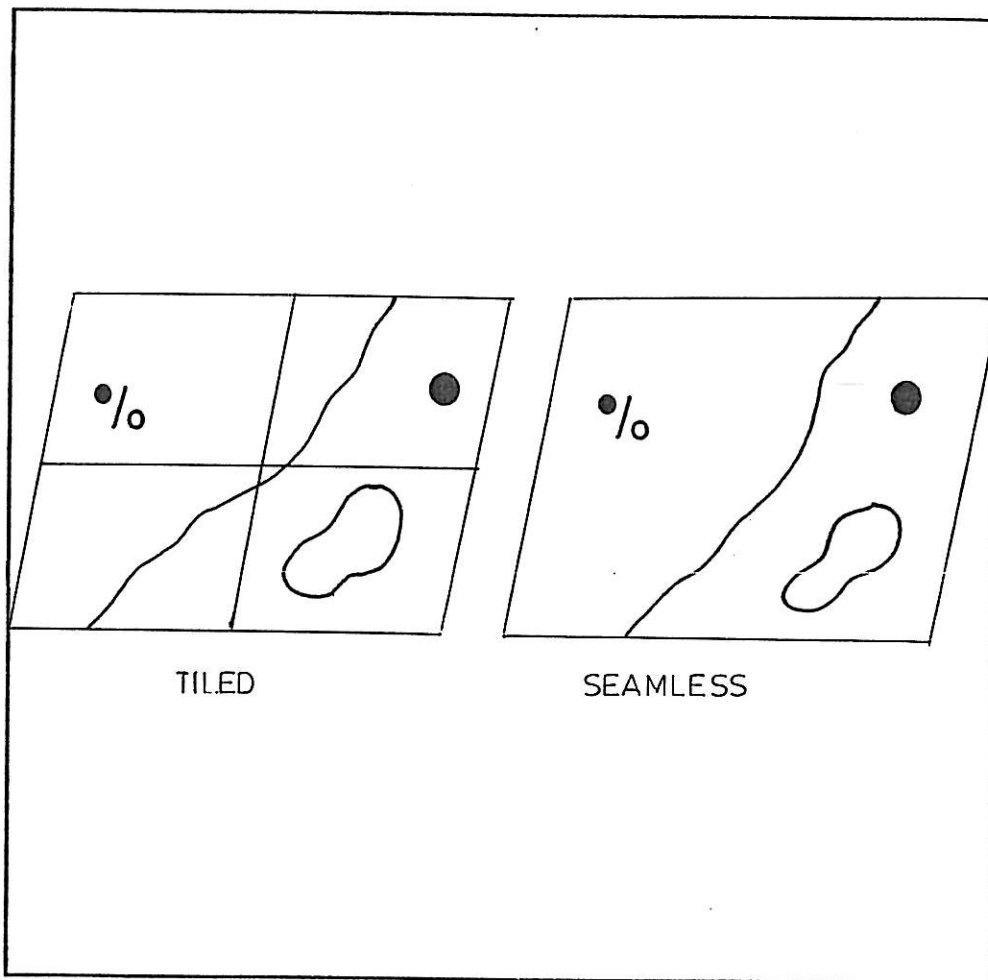

Figure 3.1
Illustration of tiled vs. seamless coverage

3.3.2 Modularity

With EPS/Prime Meridian application developers can deploy mission-critical GIS functionality in the application by incorporating the appropriate selection of Application Program Interface (API) - incrementally, as needed. Therefore, one can build function as needed. There is no need to settle for too much or too little. Thus, the value of cost-effectiveness is seen here.

3.3.3 Compliance

EPS/Prime Meridian allows third party interfaces such as attribute database, network, graphics, I/O and so forth. This will permit more headroom for performance which brings about lower overall solution cost.

CHAPTER FOUR

THE PROTOTYPE SOIL EROSION AND MODELLING SYSTEM

4.1 Overview of Eromap

The prototype software developed under this research was called the Erosion Mapper or better known as Eromap. This software was developed using Visual Basic Version 3.0 (VB) and the Spatial Structure Query Language (S²QL). The main purpose of this system is to perform soil erosion analysis based on a mathematical model. The mathematical model used in this prototype software is the well Universal Soil Loss Equation or better known as USLE.

The spatial access engine which is a powerful graphics server acting as an intermediary between the Eromap and the Prime Meridian spatial database. Visual Basic Control (VBX) of the Visual Basic programming language through Dynamic Data Exchange (DDE) communicates with the Spatial Structured Query Language (S²QL) commands. It is with these interactions that the Geographic Information System (GIS) functionality managed to embed itself into Eromap.

4.2 System Development

Prior to the development of the soil erosion modelling system, three things were taken seriously into account. They are :-

- System Design Flow
- Application Flow
- System's Directory Structure

4.2.1 System Design Flow

As with any other project, may it be large or small scale, a project work flow has to be prepare, to allow the smooth transition of the project from one phase to the other. Thus, in the development of the soil erosion modelling system (Eromap), a work flow of the system design was drawn out too. This is to facilitate the smooth system design.

Figure 4.1 outlines the system design work flow:

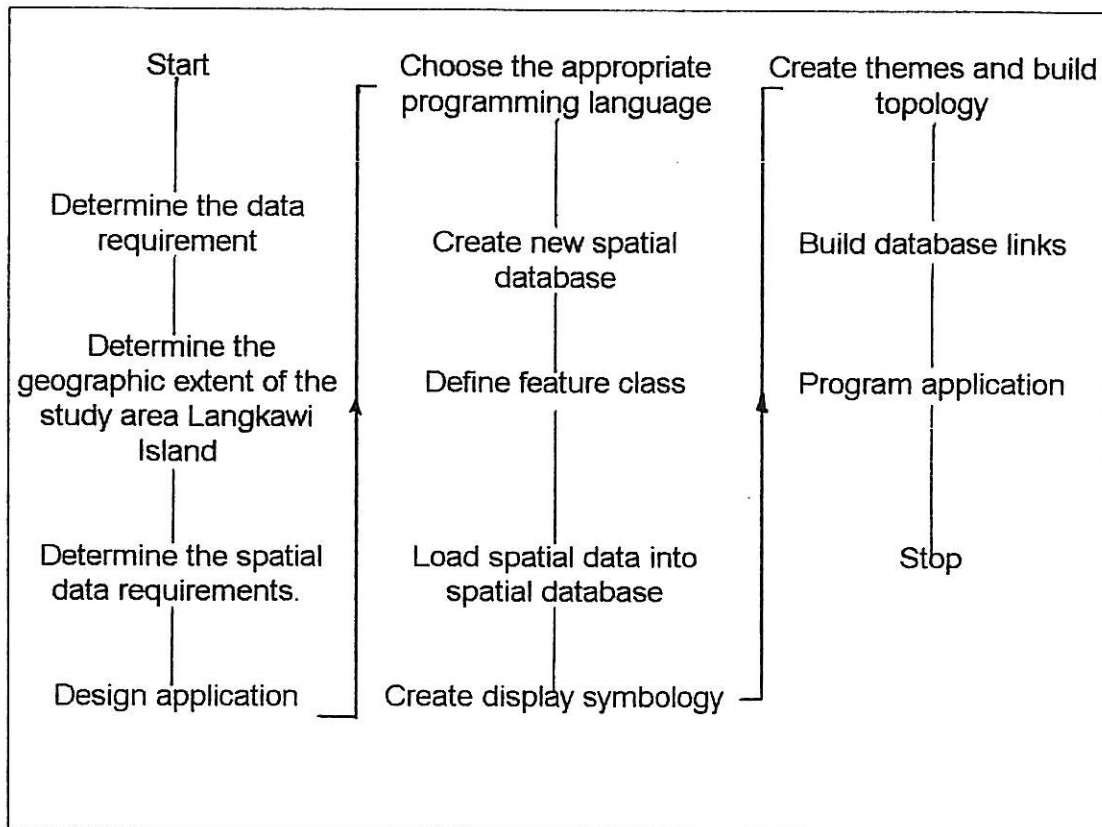

Figure 4.1
System design work flow

4.2.2 Application Flow

Before the design of any system, it is inevitable that the application flow has got to be designed. The application flow or better known as the algorithm is shown in Figure 4.2.

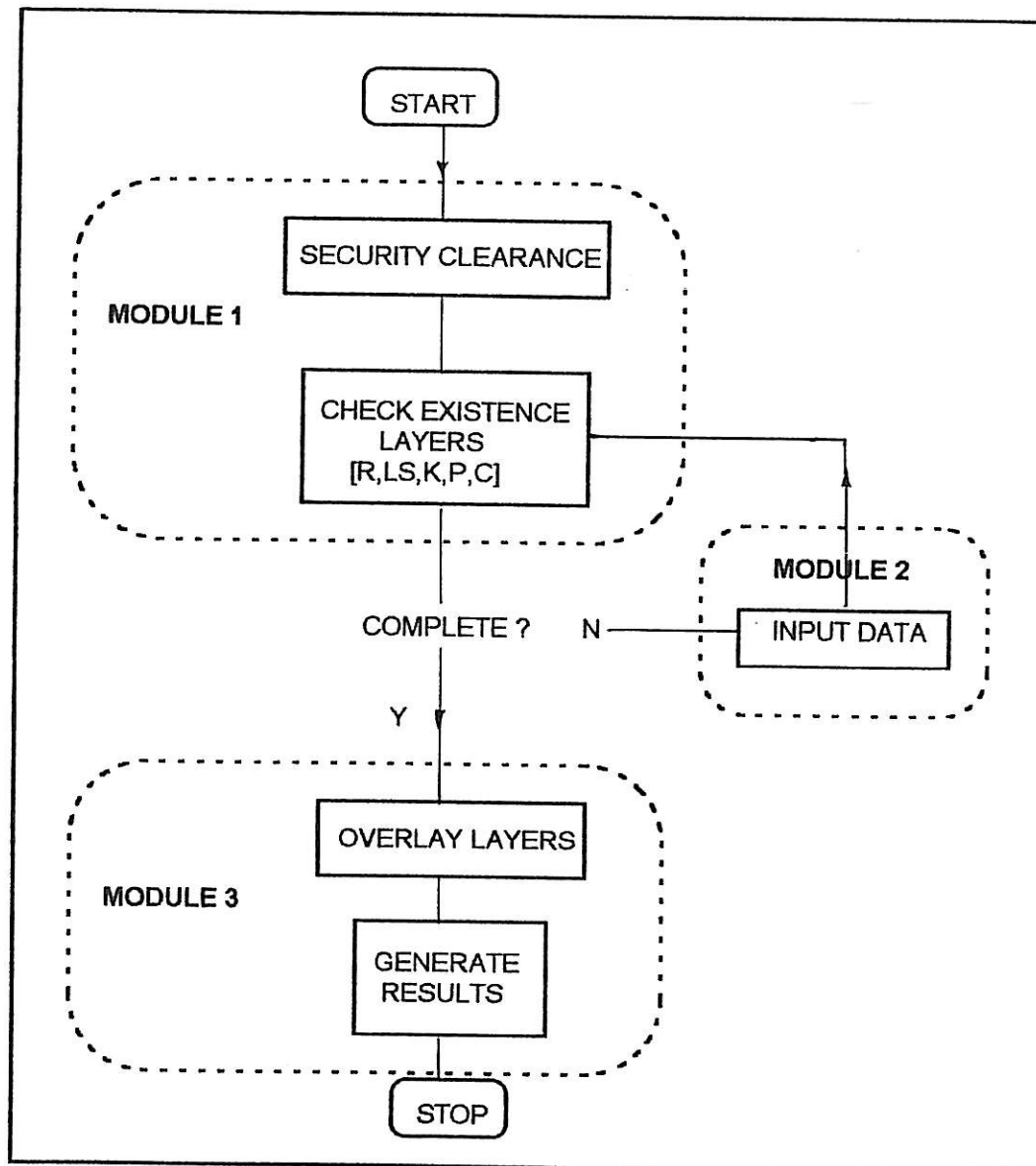

Figure 4.2
Application flow

4.2.3 System's Directory Structure

The Prime Meridian's spatial data manager manages both spatial and attribute files using a directory and subdirectory layout as illustrated in figure 4.3.

```
>C:\.....\leps_pm
    leps_pm\ pm1.x
    leps_pm\ pm1.x\ app
    leps_pm\ pm1.x\ app \am
    leps_pm\ pm1.x\ sae
    leps_pm\ pm1.x\ sae\ font
    leps_pm\sdb
    leps_pm\ sdb\ exchange
    leps_pm\ vbxdll
    leps_pm\ userdata
>C:\windows95
```

Figure 4.3
Directory hierarchy of the spatial data manager

4.2.3.1 APP Directory

The APP subdirectory is used to store the Address Matching applications and its associated files.

4.2.3.2 SAE Directory

The SAE directory contains the Prime Meridian program files, the user account data file (ACCOUNT.DAT) the error message file (TSF_ERR.DAT) and the reserved keywords file (KEYWORDS.TXT).

4.2.3.3 Font Directory

The FONT subdirectory contains the systems default font (CHAR1.FNT), custom font (FANCY??FNT), custom line type (LINETYPE.DAT) and line thickness (TSFLINES.DAT) files. The DISPSYM.DAT file contains colour mapping and Windows True Type fonts / Prime Meridian font associations.

4.2.3.4 SDB Directory

The executable files for the Spatial Data Manager are stored in the SDB subdirectory.

4.2.3.5 Exchange Directory

This directory contain program files for spatial data translation. There are two type of data translation operations: import and export. An import operation translates a Prime Meridian data exchange format file (TDEF) or a third party data format file into the Prime Meridian map file. An export operation translates data from Prime Meridian's format (TSF) into a TDEF or a third-party data format file.

4.2.3.6 VBXDLL

The VBXDLL subdirectory contains the dynamic link library files as well as additional VBX controls and DLLs required by the Spatial Data Manager. VBXDLL\INCLUDE contains interface files and modules for C and Visual Basic applications using some of the supplied DLLs. VBXDLL\LIB contains status libraries that must be linked into C programs calling DLL access functions.

4.2.3.7 Userdata Directory

This directory consists of blank user files which can be used as a starting point for building a Prime Meridian database. User account and the directory path can be established by choosing Utilities | Accounts from the Spatial Data Manager.

4.3 Program Organization

The prototype software was developed in the 32-bit Windows Programming environment. The prototype soil erosion modelling system is characterized by two major features. First, the complexity of the integrated models and geographic database is completely hidden from the user, who is only exposed to several pull-down menus and graphics-oriented user interfaces. The second feature is the most important where the system is highly modular and built with an open architecture. All of the modules, particularly the modelling components, are functional entities that can be easily replaced, extended or modified through the use of Visual Basic programming language. Thus, while being an operational Prime Meridian-based soil erosion modelling system, modifications and adjustments can easily be made.

In general, the interactive modelling environment consists of 13 sub-modules written in Visual Basic-S²QL programming language. A graphical user interface (GUI) facilitates visualization and display of the modelling results in a form of an interactive map window. Please refer to Figure 4. 4.

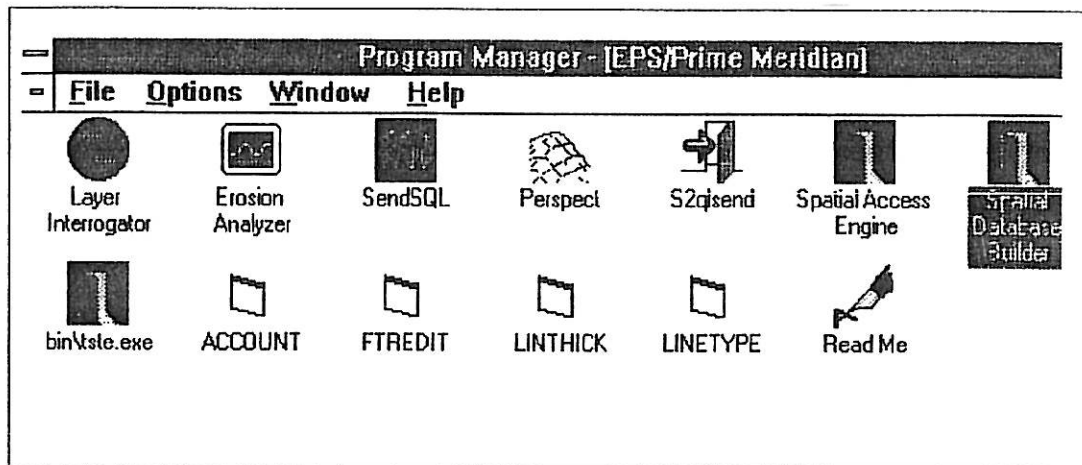

Figure 4.4.
An interactive modelling environment

Only three modules of the Eromap will be used for the soil erosion analysis. They are:

- Layer Interrogator
- Database Builder
- Erosion Analyzer

The following sections will describe the general structure of each of the three modules of the integrated soil erosion modelling system.

4.3.1 Module 1 : Layer Interrogator

This is the first module to be executed prior to any soil erosion analysis. Module 1 was created to interrogate if the user has all the USLE factors at his dispose. On top of that, it also makes sure that all the polygons representing the layers have all the values for the respective USLE factors.

Should there be a case of an incompleteness of the layers, this module will notify the user and execute Module 2 which is the Database Builder. The Database Builder is executed to perform data entries of the layers into the prototype soil erosion modelling system. Otherwise this module will execute Module 3, the Erosion Analyzer module to obtain the result. The organization chart of this module is shown in Figure 4.5 while their pseudocodes depicting this module can be seen in Figure 4.6.

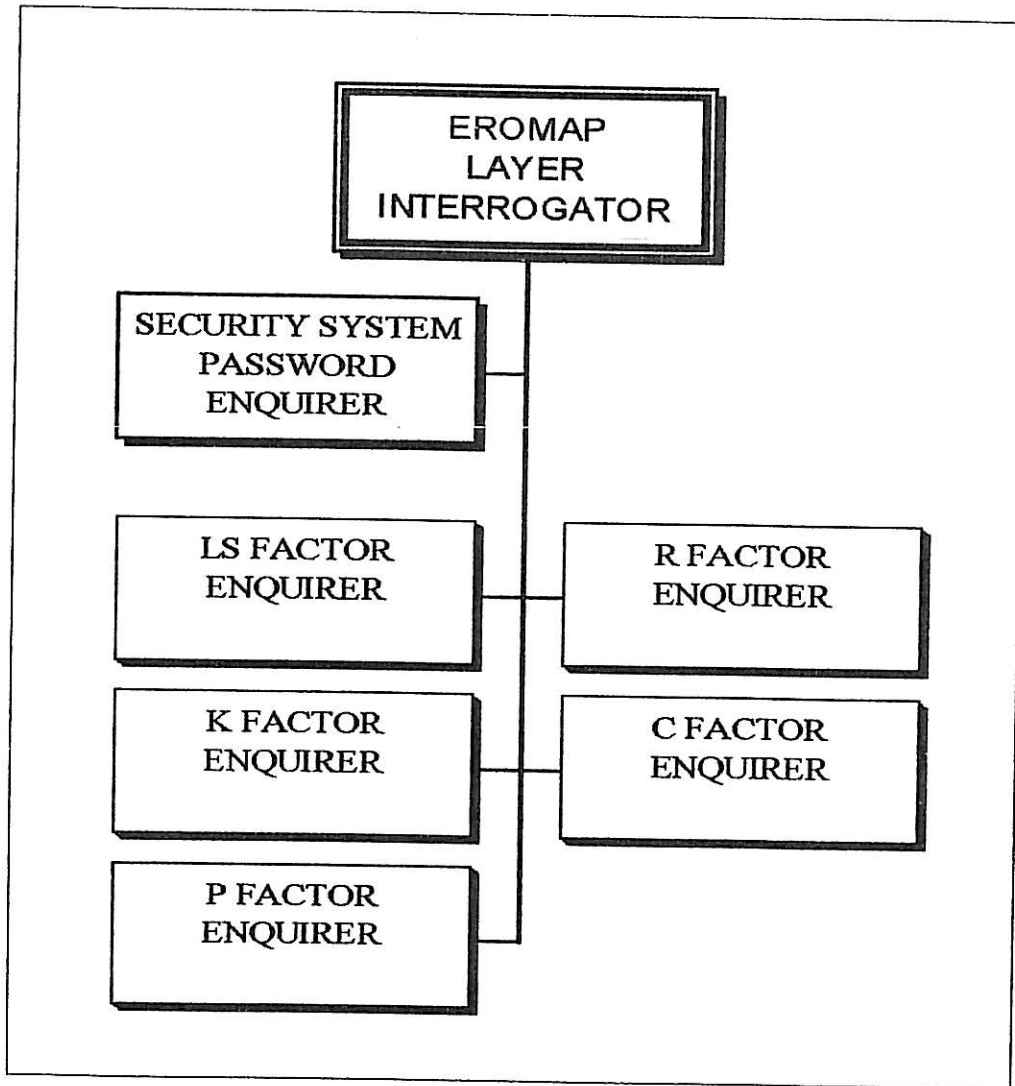

Figure 4.5.
Organization chart of Module 1

```
#include <iostream.h>
#include <graphics.h>

main()

{

// initialize graphics with auto detection of
//graphics driver and mode
initgraph (&g_driver, &g_mode, " ");

display graphics form;

cout << "USLE Layers Analyzer";
cout <<"Inquire user if all USLE factors are available"
cin >> answer ;

    if ( answer == "Y")

        { Run Erosion_Analyzer.Exe }

    else

        { cout << "What factor is not available ?"
cin>> factor ;

switch (factor)
{
case 'R' : cout << "Import ready made layers into system"
        {run Database_Builder.Exe }
        break;
case 'LS': cout << "Import ready made layers into system"
        { run Database_Builder.Exe }
        break;
case 'K' : cout << "Import ready made layer into system"
        {run Database_Builder.Exe }
        break;
case 'C' : cout << "Delineate layer using Database Builder"
        { run Database_Builder.Exe }
        break;
case 'P' : cout << "Delineate layer using Database Builder"
        { run Database_Builder.Exe }
        break;
}

}

return 0;
}
```

Figure 4.6.
Pseudocodes of Module 1

4.3.2 Module 2 : Database Builder

Module 2 is a database builder which provides spatial data input and manipulation. This Database Builder has the capability to allow the user to create custom symbols, dynamic labels and display symbologies. Thus, should the user has yet to create or delineate the layer with the polygons representing various values, this module has the option which allows one to do so. The user would need this option to create the Crop Management (P) and the Conservation Practice (C) layers. On top of that, this Database Builder can also be used to import the layers representing various USLE factors. This is especially important to import layers such as the Rainfall (R) , Soil Erodibility (K) and the Length of Slope (LS) factors.

Upon the creation of these layers, the user would also use this module for data cleaning and value designation before it can be used for further soil erosion analysis.

The organizational chart for this Database Module is illustrated in Figure 4.7.

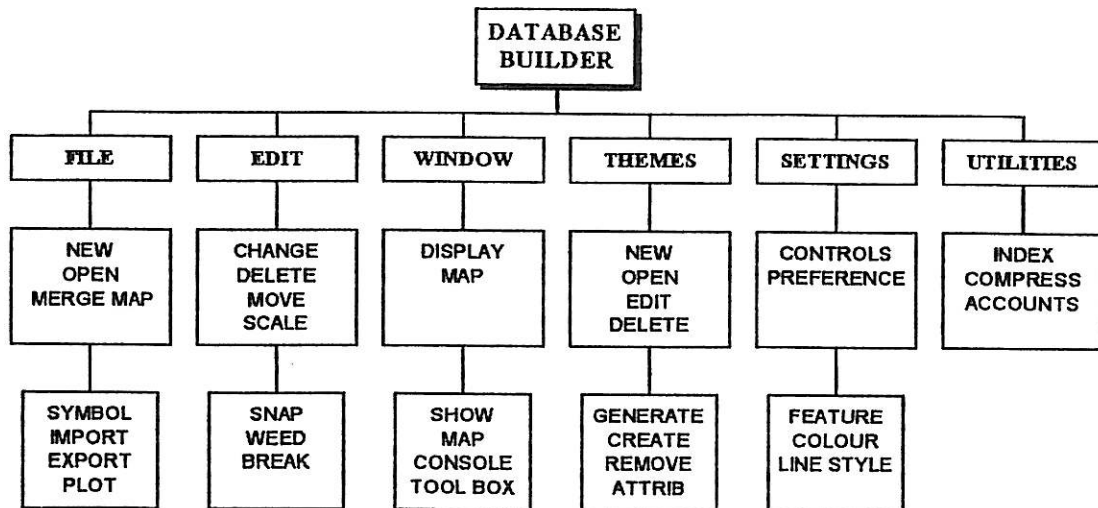

Figure 4.7.
Organization chart for Module 2

4.3.3 Module 3 : Erosion Analyzer

Module 3, Erosion Analyzer, plays a vital role in the erosion modelling system. It is the core of the soil erosion modelling and prediction system. This module performs the overlay modelling technique and consequently displays the results in a form of the soil erosion risk map on the visual display unit. The organization chart of this module is depicted in Figure 4.8.

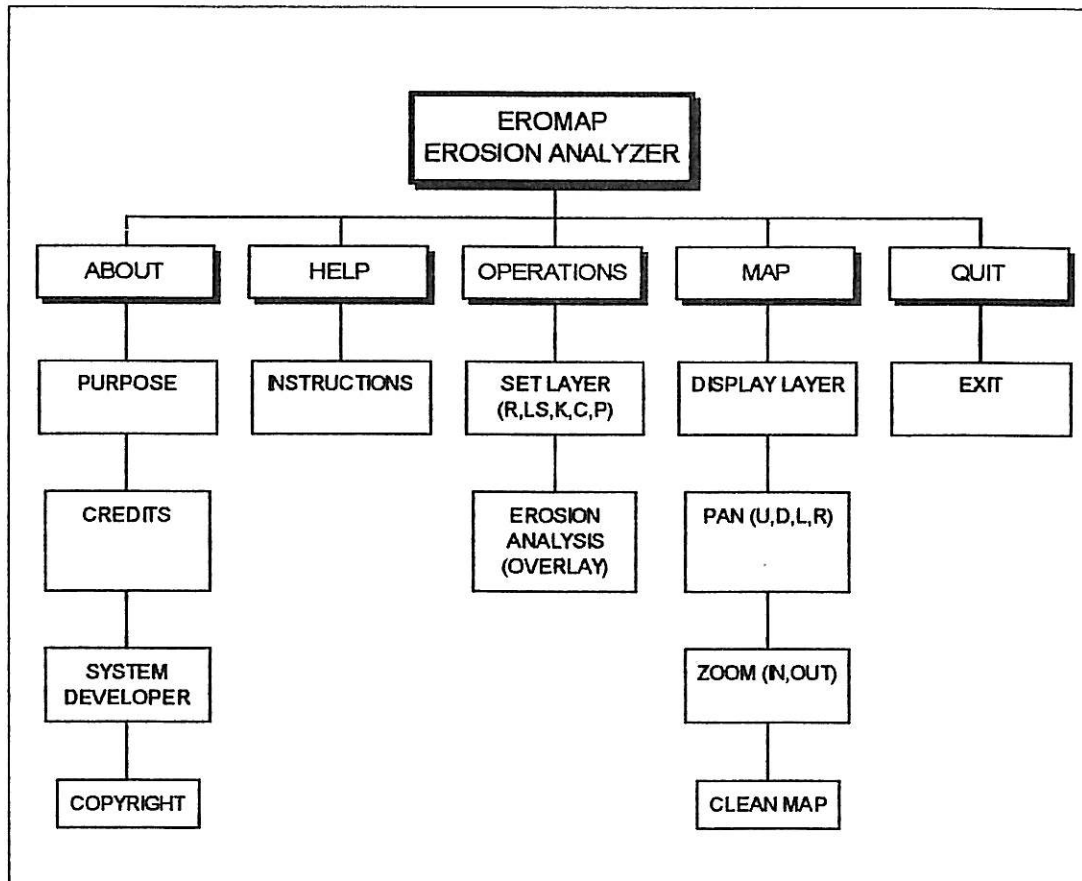

Figure 4.8.
Organization chart of Module 3

Figure 4.9 illustrates the stages involved in performing the soil erosion modelling in a form of pseudocodes.

```

#include < iostream.h >
#include < graphics.h >

main ( )
{
// initialize graphics with auto detection of graphics driver
initgraph (&g_driver, &g_mode, "");
display graphics form;
display map window;
set display limits

// Establish connections with Prime Meridian Engine (PME)
// using Dynamic Data Exchange (DDE) technique
Link_Item == "PMEngine";
Link_Topic== "PMEngine | S2QL";
Link_Execute S2QL_Command

// Check Connections
if ( Link_XXX == "Error")
{
    Cout << "Prime Meridian Engine Connection Failure !"
    Cout << " Please check the systems' connections"
}
else
{
    Extract R_layer;
    Extract LS_layer;
    Extract K_layer;
    Extract P_layer;
    Extract C_layer;

    if ( Extract_XXX == "Error" )
    {
        cout << "Layer extraction error";
        cout << "Check USLE layers again !";
    }
    else
    {
        //initialize overlay modelling of layers
        result = R * LS * K * C * P
        cout << "Display of Erosion Risk Map"<< result ;
    }
    return 0;
}
}

```

Figure 4.9.
Pseudocode of Module 3.

4.4 Software Evaluation

A typical session using Eromap is presented in this section.

All the layers representing the various factors, namely the Rainfall (R), Soil Erodibility (K), Length of Slope (LS), Crop Management (P) and Conservation Practice (C) factors were used in this evaluation session. The following steps show the process of soil erosion analysis using Eromap.

- o C: \ WIN

A window display of Eromap will be shown as in Figure 4.10.

- o **Select Layer Interrogator**
[Click the Layer Interrogator icon]
The system will initiate the Layer Interrogator module.



Figure 4.10
Window display of Eromap

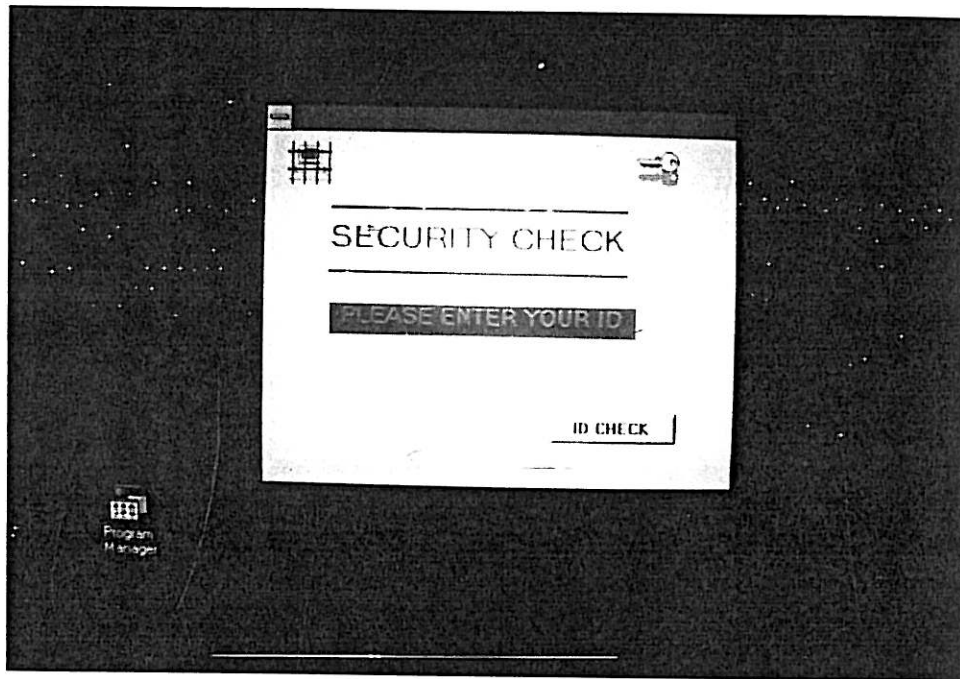

Figure 4.11

- o **Enter Password**
[See Figure 4.11]
This is for the purpose of system's security clearance.

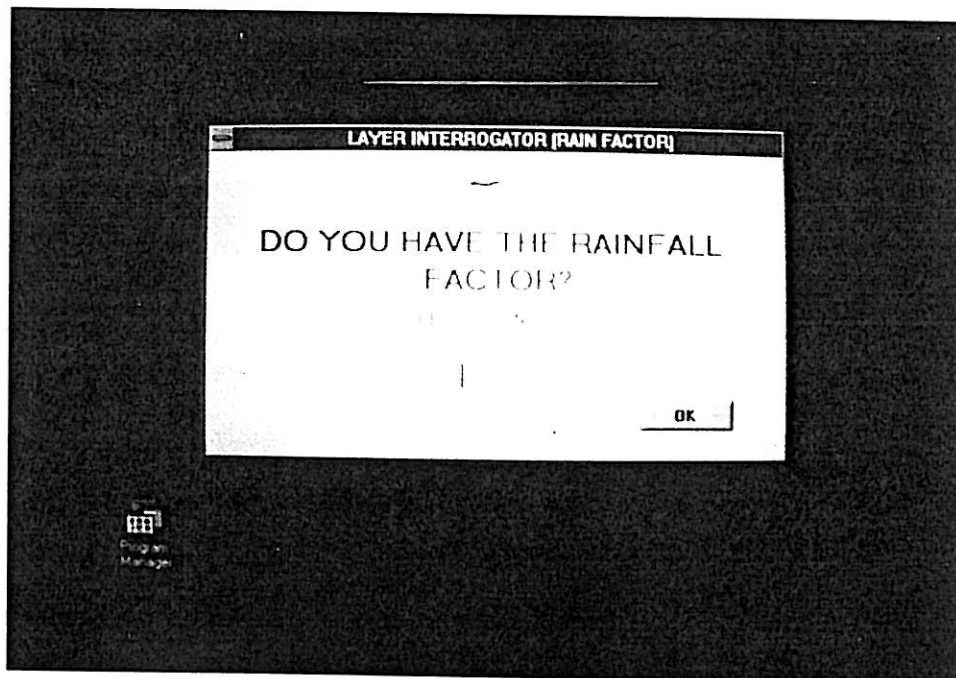

Figure 4.12

- o **Answer all the System Interrogator's inquiries.**
[See Figure 4.12.]

Should there be any incomplete layers, the system will summon the Database Builder module as in Figure 4.13.

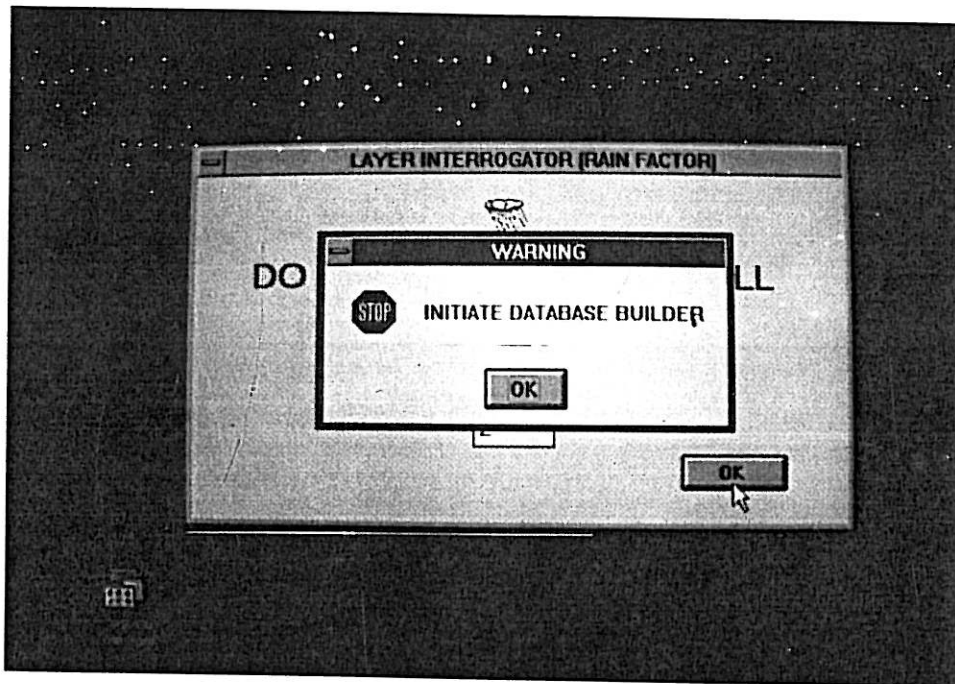

Figure 4.13

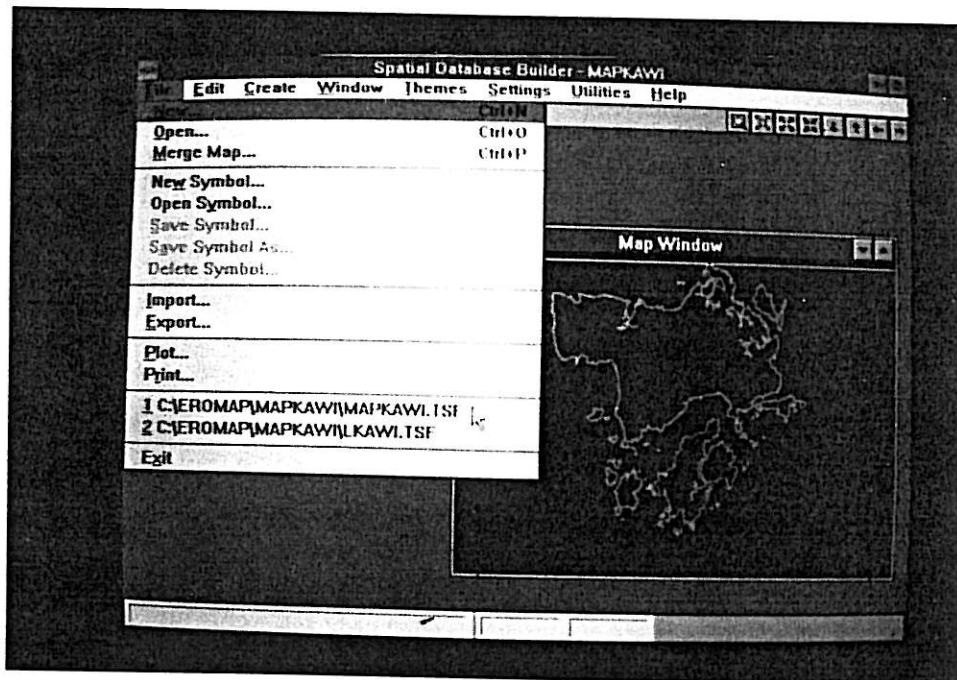

Figure 4.14

- o Call up the base map from the system.
[Click File from the menu bar as in Figure 4.14.]

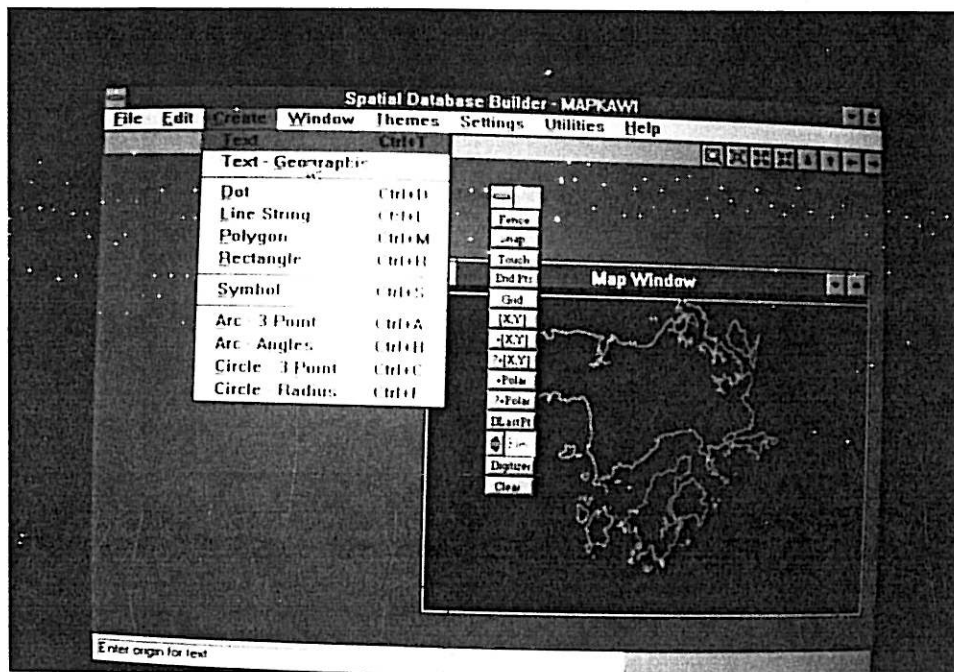

Figure 4.15

- o Delineate the polygon representing the USLE factor.
[Use the tools from the Tool Bar as in Figure 4.15.]

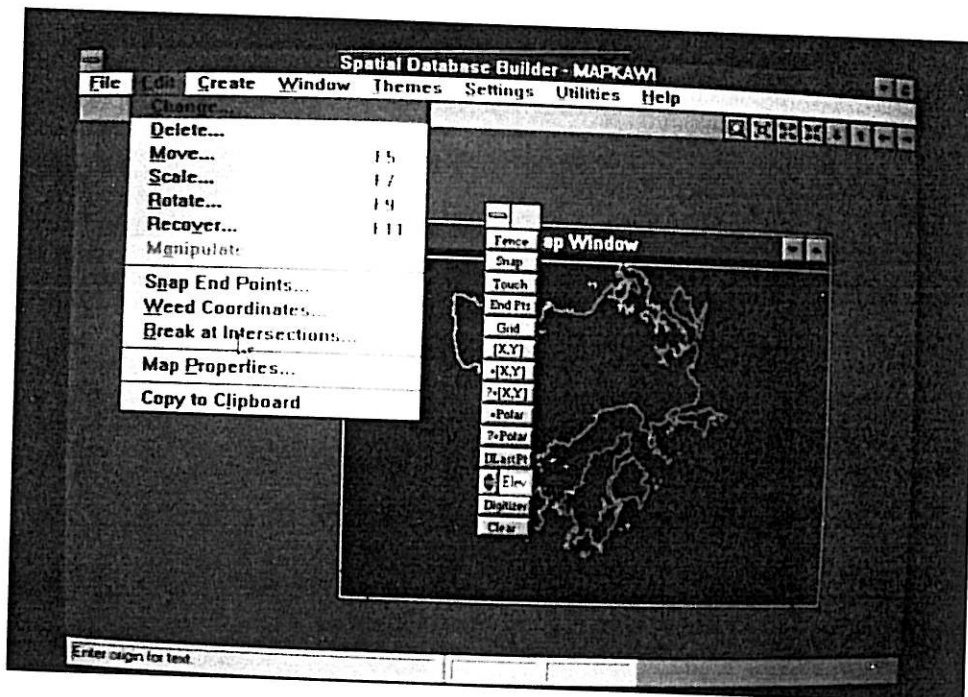

Figure 4.16

- o Clean under-shoot and over-shoot polylines.
[Use the Edit command from the menu bar as in Figure 4.16.]

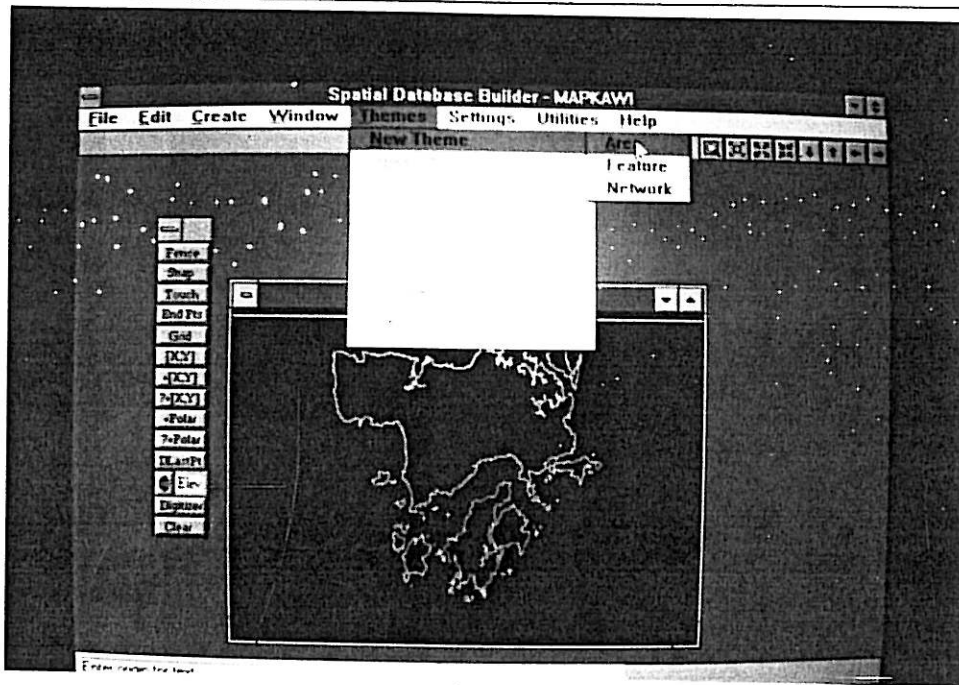

Figure 4.17

- o Assign the polygons in the layer with respective values.
[Use the Themes command from the menu bar as in Figure 4.17.]

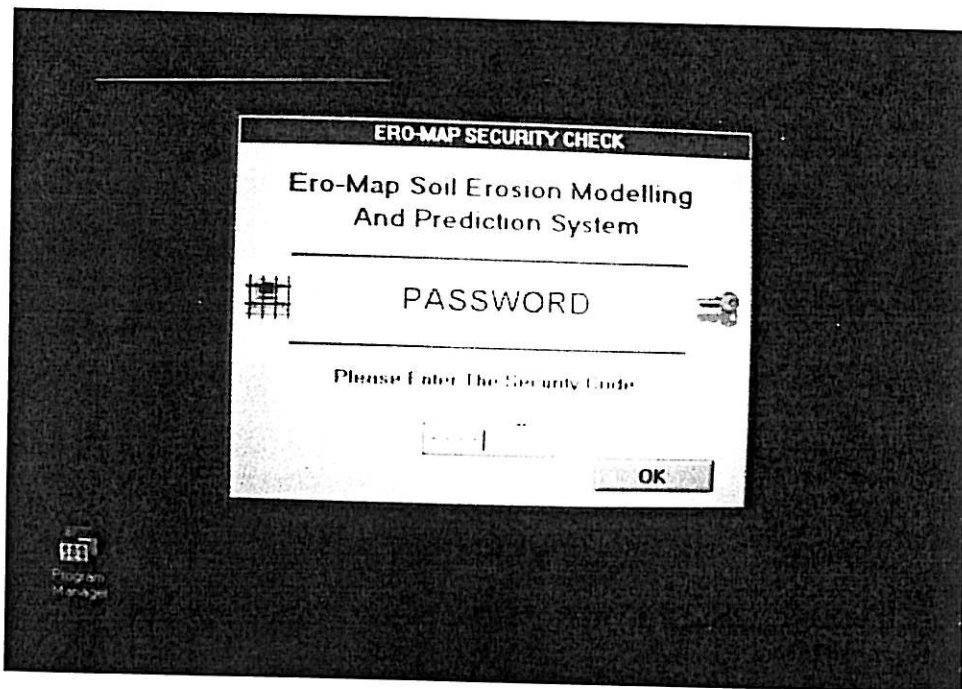

Figure 18

- o Initiate the Erosion Analyzer module.
[Click the Erosion Analyzer icon from the window]
- o [Clear the security system with the password as in Figure 4.18.]

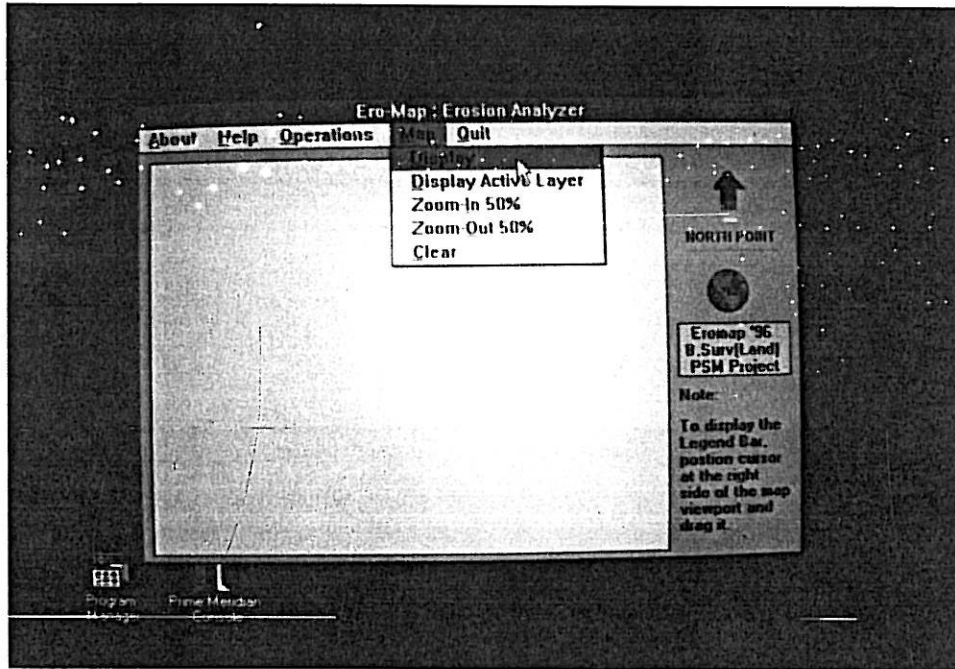

Figure 4.19

- o Display map window
[Click the Display Map command from the menu bar as in Figure 4.19.]

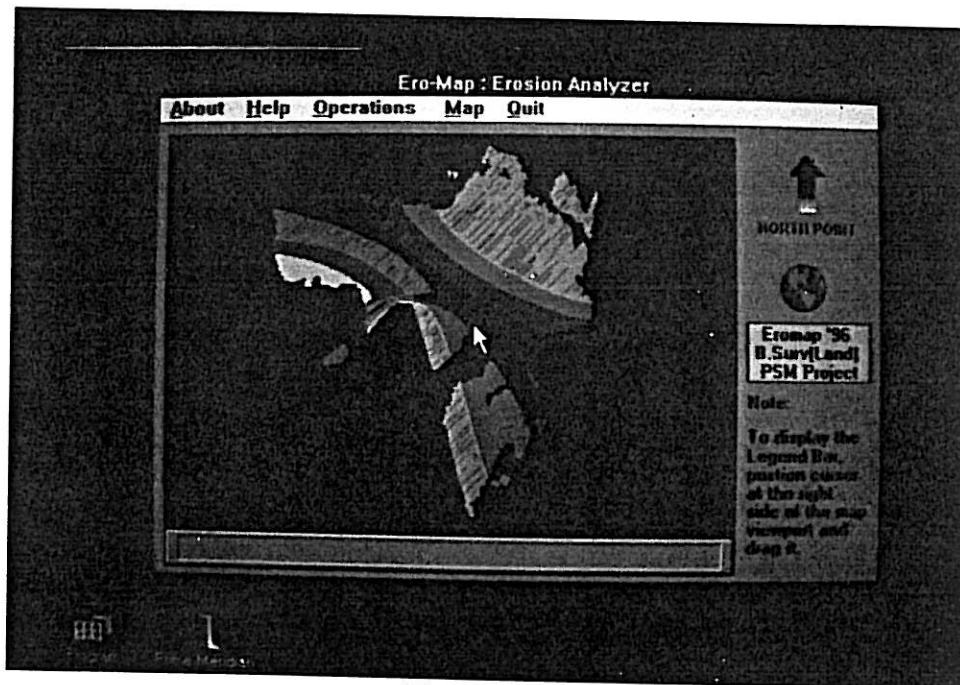

Figure 4.20

- o Check for Rainfall Factor through display
[Click Display R Factor command as in Figure 4.20.]



Figure 4.21

- o Check for Length of Slope (LS) Factor
[Click Display LS Factor command as in Figure 4.21.]

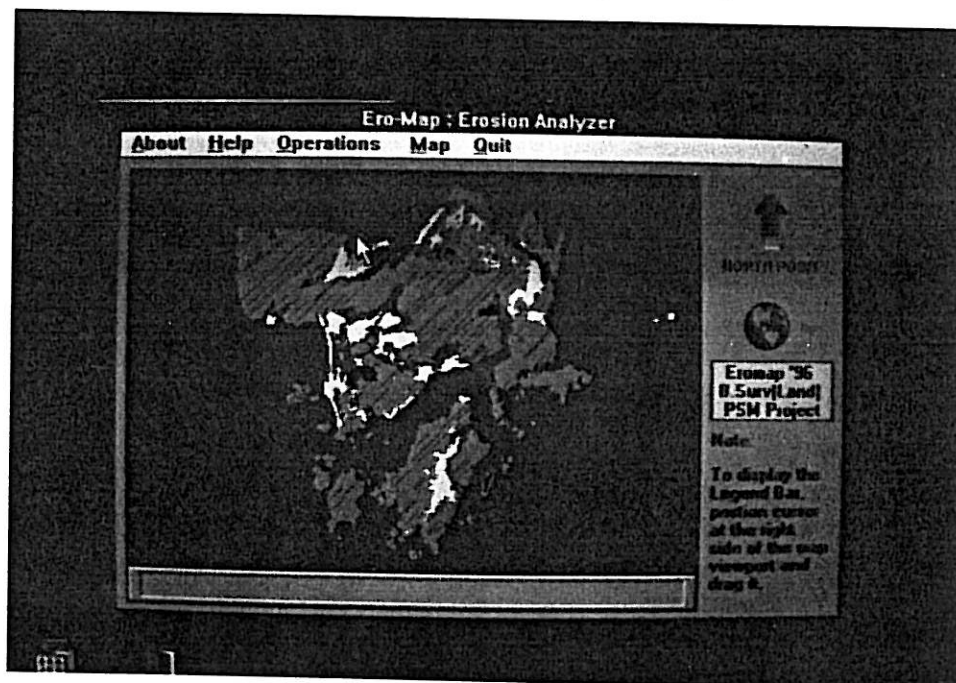

Figure 4.22

- o Check for Soil Erodibility (K) Factor
[Click Display K Factor command as in Figure 4.22.]



Figure 4.23

- o Check for Crop Management (P) Factor
[Click Display P Factor command as in Figure 4.23.]

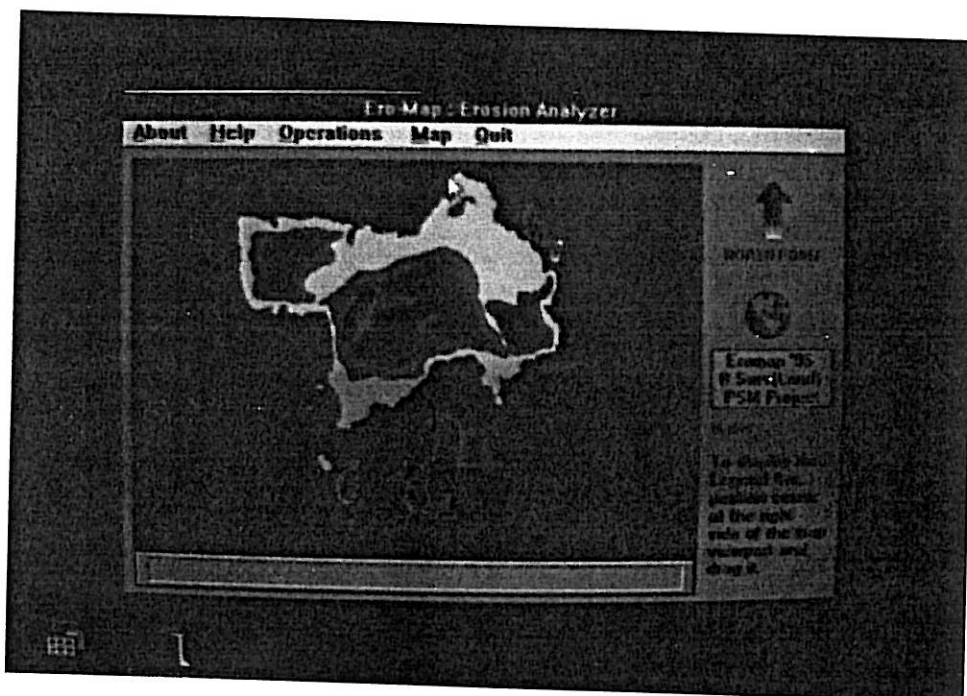

Figure 4.24

- o Check for Conservation Practice (C) Factor
[Click Display C Factor command as in Figure 4.24.]

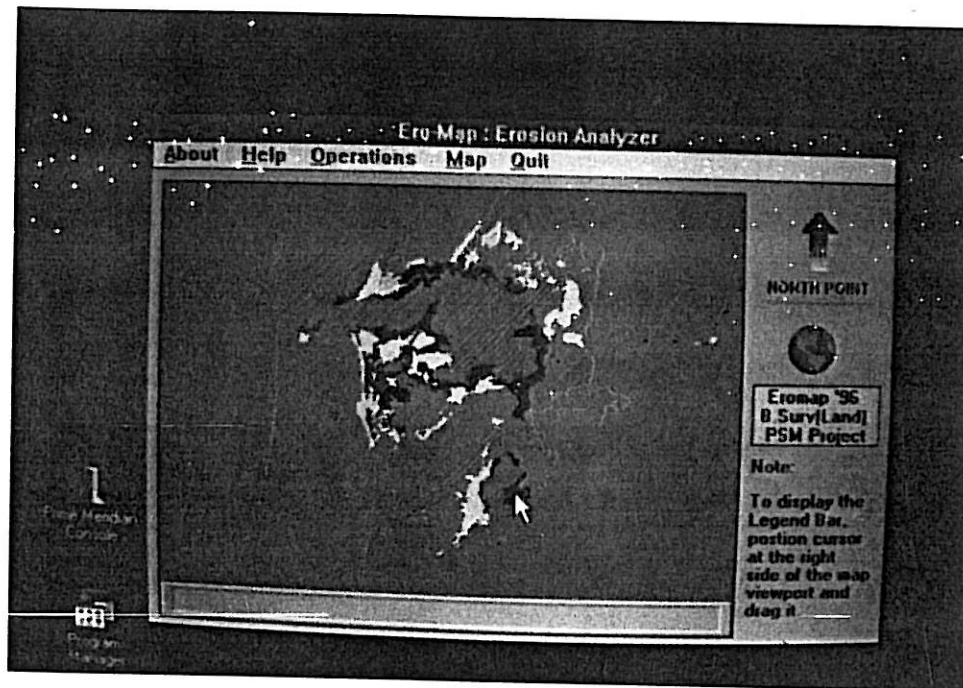

Figure 4.25

- o **Initiate Erosion Analysis from the menu bar**
[Click Erosion Analysis command as in Figure 4.25.]

The output from this stage is the output of the Soil Erosion Risk Map.

CHAPTER FIVE

THE RESULTS AND ANALYSIS

5.1 Introduction

It is undeniable that this prototype software was developed successfully. Nevertheless, as with any products, tests had to be conducted and results had to be generated for the purpose of software evaluation. Sample test data of Langkawi Island was used in this evaluation. The layers involved were :

- Rainfall (R) Factor
- Soil Erodibility (K) Factor
- LS Factor (LS)
- Crop management (P) Factor
- Conservation Practice (C) Factor

The test data was supplied by the Malaysian Agriculture Department (Jabatan Pertanian Malaysia) in a hardcopy form. The data was converted into the digital format by digitizing it into the Autocad platform. The Autocad system then exported it into the DXF format. The Database Builder was used to import the DXF format into the TSF format of the Eromap system.

The evaluation will be centred on four questions, namely:-

- Is the modelling system efficient and reliable?
- Is the system performing the procedures properly ?
- Is the system presenting the results in an acceptable and effective cartographic fashion ?
- What are the limitations ?

5.2 Efficiency and Reliability of Eromap

Eromap has an interactive and menu-driven interface that guides the user with prompt and explain messages through the application. There is no need for any command language of other special format of interaction. Eromap assists the user in its proper use and consequently increases the system's user-friendliness.

The system has no human interventions in its processing except for the layer development stage if there is a need. This fact reduces the introduction of errors in the layers which will have a significant effect over the results of the overlay modelling operations. Minimum or no errors introduced in the data layers will preserve the accuracy of the data. Consequently, accurate results of the soil erosion risk map will be generated.

5.3 The Performance of Eromap

Eromap was developed in a 32-bit programming platform. The minimum requirements for Eromap to run well are as follows:

- An 80486-based IBM-compatible PC.
- DOS Version 3.22 or a later version.
- A mouse or digitizing tablet.
- A display system that can display graphics. A monitor with the resolution of at least 800 X 600 pixels that displays at least 16 colours is recommended for production CAD work. In most cases, even higher resolution and a 19-inch or larger monitor is desirable.
- Sufficient RAM. The recommended size is 12 MB.
- At least 50 MB free space on a hard drive after installation.

Erosion analysis of the Langkawi Island test data took less than 1 second on such a system configuration.

This prototype soil erosion modelling system can perform two different types of overlays. They are the vector overlay and the raster overlay. The overlay modelling technique used in this project was the vector overlay. This is mainly due to the fact that the supplied data was in a vector form.

5.4 The Presentation Capabilities of Eromap

In this soil erosion modelling and prediction project, Isopleths maps of the Isarithmic categories were generated in both the digital and analogue format.

In the digital format, dynamic colour graphics for the model output and symbolic representation of the results of the erosion analysis allow easy and immediate understanding of basic patterns and relationships for the user.

In order to examine the system's cartographic production capabilities from a closer point of view, a few hardcopies were plotted using the Hewlett Packard Design Jet III. The hardcopies of the Rainfall (R) Factor, Length of Slope (LS) Factor, Soil Erodibility (K) Factor and the resultant Soil Erosion Risk Map can be viewed from Appendices I through IV respectively.

The results from the hardcopies were very encouraging and these provide the user with full-confidence of the system. On top of that, this would also mean that this system has a very good cartographic capabilities.

5.5 Limitations of Eromap

As with other designs and inventions, all products have their strengths and weaknesses. In Eromap, there exists a predicament associated with the mathematical overlay modelling of one of the layers.

For Eromap to be able to perform the erosion analysis, the LS factor has to be of a single layer. That means this system can only perform overlay modelling using the LS factor which is the resultant of the product between the length of slope (L) layer and the slope angle (S) produced by some other platforms. It must be noted that the inability to break the LS factor will cause a lost of accuracy. Heuvelink, Burrough and Stein (1989) have studied that the products of length of slope (L) and the slope angle (S) will always be greater than the actual values. This is due to the error propagation of L and S values of the equation below :

$$LS = (L/22)^{0.5} (0.065 + 0.0458 + 0.0065S^2)$$

There are two techniques to overcome this perplexity. They are :

- Separation of The LS Factor
- Increment of The Display Resolution

5.5.1 Separation of The LS Factor

This error can be minimized by separating the LS factor into the Slope Angle and the Length of Slope respectively. The separation of LS factor will definately increase the accuracy of the system. Nevertheless, field studies need to be conducted before the L and S factors can be obtained.

5.5.2 Increment of The Display Resolution

Another method to overcome the problem of inaccuracy is to increase the resolution of the display system. As the resolution gets higher, the soil erosion can be accurately modelled. The erosion estimates will approach actual values. The method proves to be practical in cases where field studies are impractical. On top of that, this method offers the best solution with the available (LS Factor) data.

CHAPTER SIX

REVIEWS, CONCLUSION AND RECOMMENDATIONS

Geographic information systems technology is spreading rapidly, largely due to the continuing revolution in computer hardware. In the next decade, it will definitely become the backcloth on which most environmental assessment, planning and management will take place. Thus, GIS technology must now be seen as providing the basic frame work for processing large volumes of spatial data and describing spatial environmental processes. This implies the need to begin to integrate both traditional and new tools for environmental analysis and modelling.

It is undeniable that Geographic Information System (GIS) has been in the arena of erosion analysis not less than fifteen years. The recent development of GIS is not limited to soil profile data. Developments in mapping technology, interpolation methods, remote sensing and modelling have provided environmental agencies with useful tools that are used for standard productions of maps and environmental impact assessment reports. The purpose of this study is to develop such a system which can model and predict soil erosions.

The system developed in this project is the Eromap, a soil erosion modelling and prediction system which utilizes the Universal Soil Loss Equation (USLE) developed by Wischemier and Smith in 1962.

The two main objectives of this research have been successfully achieved through Eromap. With Eromap, one is able to analyze soil erosion loss using Prime Meridian GIS' Spatial Database Engine (SDE). In addition to that, Eromap permits the user to generate soil erosion risk maps. This system also provides the user with a high level of confidence with the capability and applicability for erosion analysis of environmental impact assessments. As a result of Eromap being able to handle much larger volumes of data, one has come to grip with the difficult problems of describing the spatial variation of soil erosions.

Though Eromap has successfully being developed, nevertheless, this prototype software can further be improved in the area of mathematical modelling. At the time of this writing, the resultant LS factor has yet to be broken up into Slope Angle (S) and Length of Slope (L) respectively. The author recommends that there should be a further research into the separation of LS factor in order to achieve a better accuracy of the resultant soil erosion risk map.

In general, this developed prototype system in its present form achieves the research objectives and is a sufficiently realistic demonstration of the flexibility of GIS technology. It also shows that ability to interactively model water quality problems within the GIS environment.

References

- Bergsma, E. (1983). "Rainfall Erosion Surveys For Conservation planning." *ITC Journal*, 1983-2, pp. 166-175
- Chakroun, Bonn and Fortin (1992). "Combination of Single Storm Erosion and Hydrological models into A Geographic information System.", *Proceedings of the International Symposium on Farm Land Erosion*, Paris, Saint-Cloud, France, 25-26 May 1992, pp. 261-270.
- Craig, J.C. (1993). "*Visual Basic Workshop.*", Washington : Microsoft Corp.
- Department of Environment. (1988). *A handbook of Environmental Impact Assessment Guidelines*, Ministry of Science Technology and Environment, Malaysia
- Foth, H. (1984). "*Fundamentals of Soil Science.*" 7th ed. New York: John Wiley and Sons. pp. 373-385.
- Gurewich, N. (1994). "*Master Visual Basic 3.*" 1st ed. Indiana : Prientice Hall Macmillan.
- Liao, H.H. and Udoyara, T. (1994). "Interactive Water Quality Modeling Within A GIS Environment." *Computer, Environment and Urban Systems*, Vol. 18, No. 5; pp. 343-363.
- Mann, A.T. (1995). "*Real-World Programming with Visual Basic.*" Indianapolis, Indiana : SAMS Publishing.

- McGuire and Mustafa (1995). "Erosion Risk Map of Pulau Langkawi.", *Seminar of Hydrology of Small Islands Pulau Langkawi*, April 1995, Pulau Langkawi.
- Miller and Donahue (1990). "*Soils : An Introduction To Soils And Plant Growth.*" 6th ed. London : Prentice-Hall. pp. 446-475.
- Morgan, R.P.C. (1986). "*Soil Erosion And Conservation.*" 1st. ed. London: Longman, pp.111-133.
- Oslon, G. (1981). "*Soils And The Environment : A Guide to Soil Surveys and Their Applications.*" 1st. ed. London : Chapman and Hall. pp. 105-118.
- Senn, J.A. (1989). "*Analysis and Design of Information Systems.*" 2nd ed. New York: McGraw-Hill Publishing.
- Smith, D.D. and Wisheimeier, W.H. (1957). *Factor affecting sheet and rill erosion.* 1st ed. Trans. Am. Geography Union.

APPENDICES

- APPENDIX 1 : RAIN EROSIVITY FACTOR (R)
- APPENDIX 2 : SOIL ERODIBILITY FACTOR (K)
- APPENDIX 3 : LENGTH OF SLOPE FACTOR (LS)
- APPENDIX 4 : SOIL EROSION RISK MAP
- APPENDIX 5 : EROMAP PROTOTYPE SOURCE CODE

SOIL EROSION MODELLING AND PREDICTION MAP OF LANGKAWI ISLAND

SCALE 1 : 100 000

RAINFALL MAP (R FACTOR) OF THE ISLAND

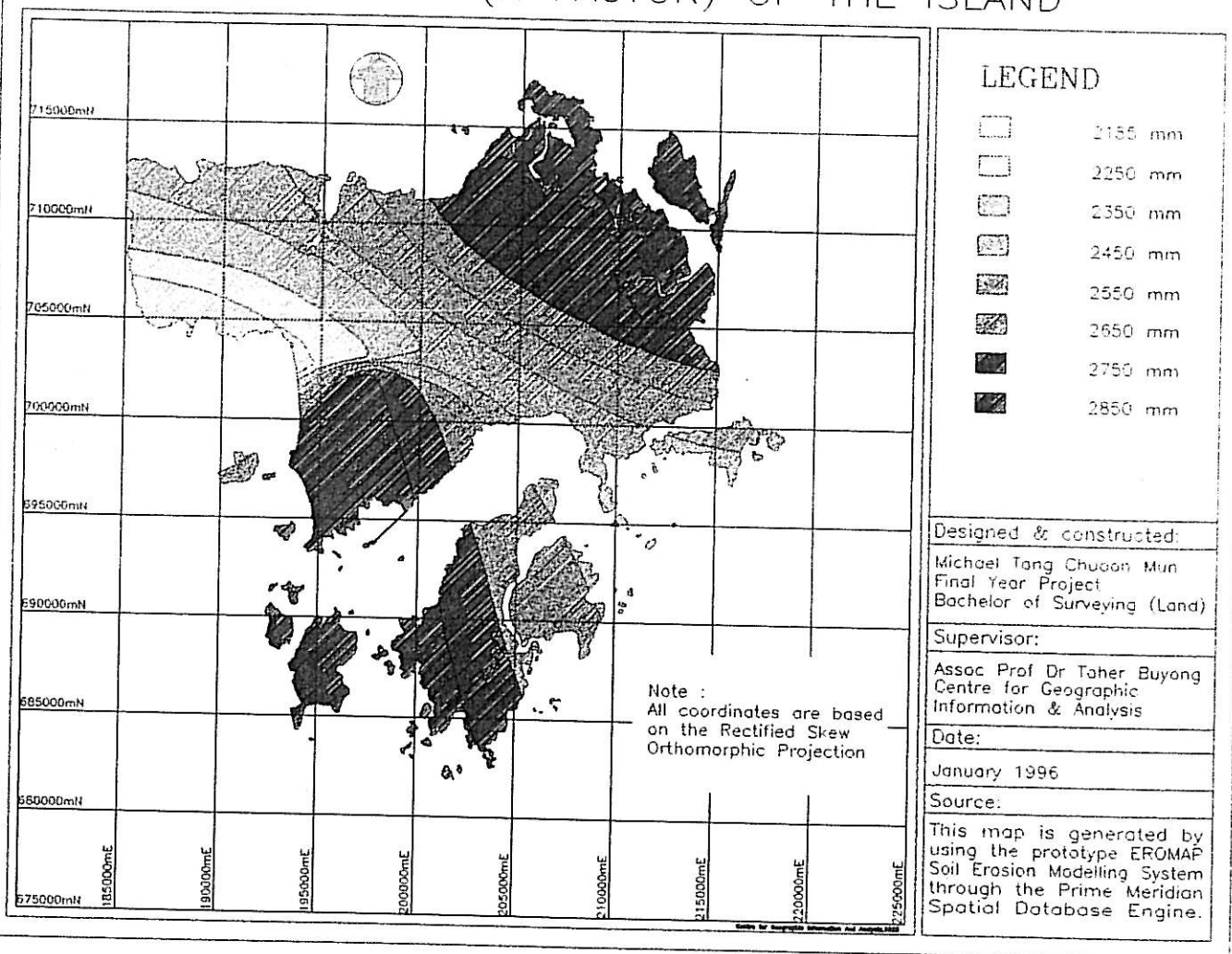

Appendix 1
Rain Erosivity Factor (R)

SOIL EROSION MODELLING AND PREDICTION MAP OF LANGKAWI ISLAND

SCALE 1 : 100 000

SOIL ERODIBILITY (K FACTOR) OF LANGKAWI ISLAND

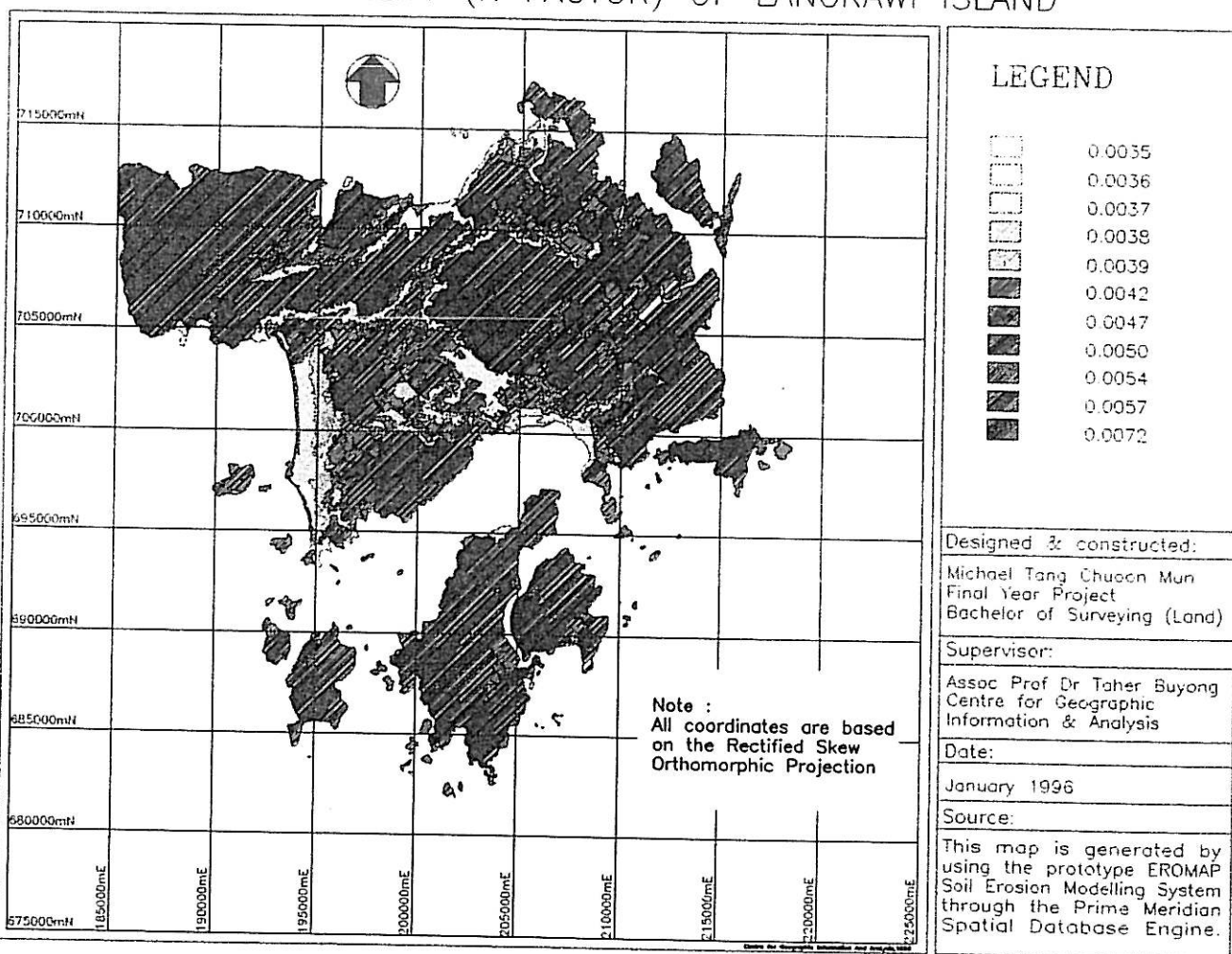

Appendix 2
Soil Erodibility Factor (K)

SOIL EROSION MODELLING AND PREDICTION MAP OF LANGKAWI ISLAND

SCALE 1 : 100 000

LENGTH OF SLOPE (LS FACTOR) OF LANGKAWI ISLAND

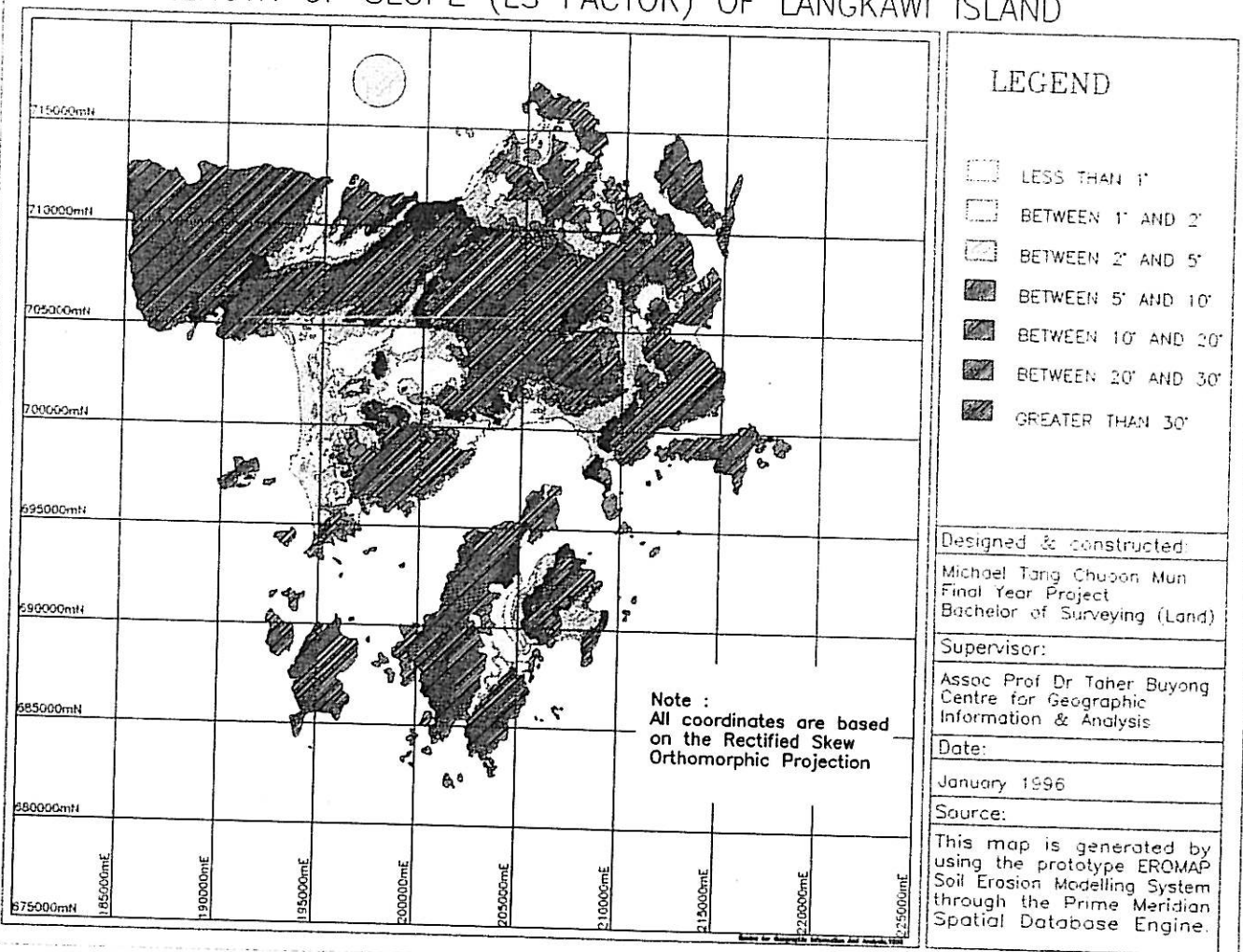

Appendix 3
Length of Slope Factor (LS)

SOIL EROSION MODELLING AND PREDICTION MAP OF LANGKAWI ISLAND

SCALE 1 : 100 000

EROSION RISK MAP OF LANGKAWI ISLAND

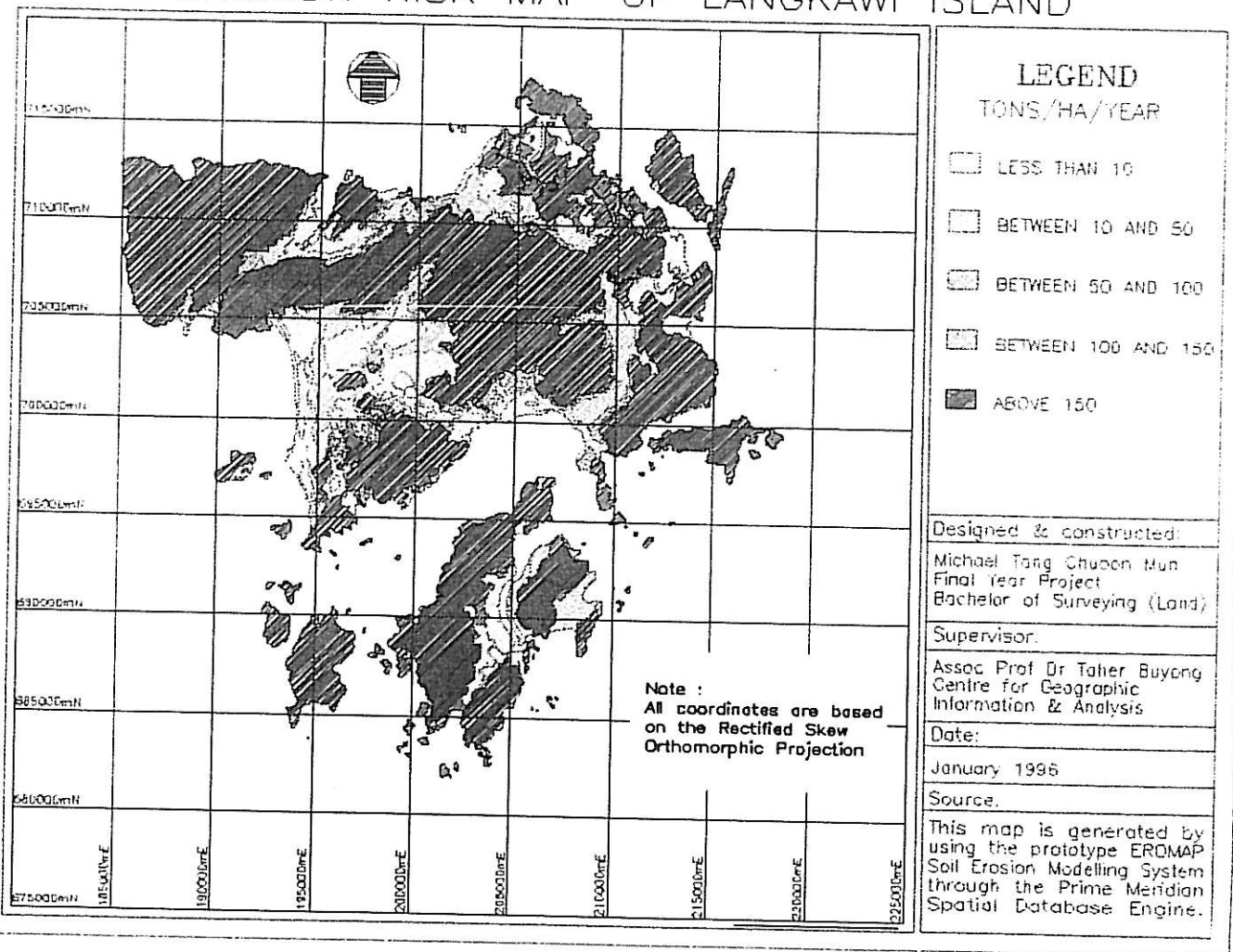

Appendix 4
Soil Erosion Risk Map

Appendix 5
Eromap Prototype Source Code

VERSION 2.00

Begin Form Credits

```
BackColor      =  &H00E0FFFF&
BorderStyle    =  1  'Fixed Single
Caption        =  "Credits"
ClientHeight   =  4185
ClientLeft     =  1920
ClientTop      =  1575
ClientWidth    =  6255
ControlBox     =  0  'False
FillStyle      =  2  'Horizontal Line
FontBold       =  -1  'True
FontItalic     =  0  'False
FontName       =  "Courier"
FontSize       =  9.75
FontStrikethru =  0  'False
FontUnderline  =  0  'False
Height         =  4590
Left           =  1860
LinkTopic     =  "Form1"
MaxButton      =  0  'False
MinButton      =  0  'False
ScaleHeight    =  4185
ScaleWidth     =  6255
Top            =  1230
Width          =  6375
```

Begin CommandButton Command1

```
BackColor      =  &H00FFFF00&
Caption        =  "Close"
FontBold       =  -1  'True
FontItalic     =  0  'False
FontName       =  "Arial"
FontSize       =  9
FontStrikethru =  0  'False
FontUnderline  =  0  'False
Height         =  375
Left           =  4680
TabIndex       =  0
Top            =  3600
Width          =  975
```

End

Begin Image Image1

```
Height         =  480
Left           =  2760
Picture        =  (Icon)
Top            =  120
Width          =  480
```

End

Begin Label Label1

```
Alignment      =  2  'Center
BackColor      =  &H00E0FFFF&
Caption        =  "The author would like to thank
FontBold       =  -1  'True
FontItalic     =  -1  'True
FontName       =  "Times New Roman"
FontSize       =  13.5
FontStrikethru =  0  'False
FontUnderline  =  0  'False
```

CREDITS.FRM - 2

```
    ForeColor      =    &H00FF0000&  
    Height         =    2655  
    Left           =    240  
    TabIndex       =    1  
    Top            =    720  
    Width          =    5775  
End  
End
```

CREDITS.FRM - 1

```
Sub Command1_Click ()  
Credits.Hide  
Unload Credits  
GISMAIN.Show  
End Sub
```

HELP.FRM - 1

VERSION 2.00

Begin Form Help

```
BackColor      = &H00E0E0E0&
BorderStyle    = 1  'Fixed Single
Caption        = "HELP"
ClientHeight   = 3525
ClientLeft     = 1425
ClientTop      = 1815
ClientWidth    = 6990
ControlBox     = 0  'False
ForeColor      = &H00E0E0E0&
Height         = 3930
Left           = 1365
LinkTopic      = "Form1"
MaxButton      = 0  'False
MinButton      = 0  'False
ScaleHeight    = 3525
ScaleWidth     = 6990
Top            = 1470
Width          = 7110
```

Begin CommandButton Command1

```
BackColor      = &H0080C0FF&
Caption        = "Close"
Height         = 375
Left           = 5400
TabIndex       = 1
Top            = 2880
Width          = 1095
```

End

Begin Label Label1

```
Alignment      = 2  'Center
BackColor      = &H008080FF&
BorderStyle    = 1  'Fixed Single
Caption        = "Please refer to the accompanied
FontBold       = -1  'True
FontItalic     = -1  'True
FontName       = "Times New Roman"
FontSize       = 13.5
FontStrikethru = 0  'False
FontUnderline  = 0  'False
ForeColor      = &H00FF0000&
Height         = 2055
Left           = 240
TabIndex       = 0
Top            = 720
Width          = 6495
```

End

Begin Image Image1

```
Height         = 480
Left           = 3120
Picture        = (Icon)
Top            = 120
Width          = 480
```

End

End

HELP.FRM - 1

Sub Command1_Click ()

Help.Hide

Unload Help

GISMAIN.Show

End Sub

VERSION 2.00

Begin Form PURPOSE

```
BackColor      = &H0080C0FF&
BorderStyle    = 3  'Fixed Double
Caption        = "Purpose of Ero-Map"
ClientHeight   = 4305
ClientLeft     = 1290
ClientTop      = 1710
ClientWidth    = 7080
ControlBox     = 0  'False
FillColor      = &H00FF0000&
Height         = 4710
Left           = 1230
LinkTopic     = "Form1"
MaxButton      = 0  'False
MinButton      = 0  'False
ScaleHeight    = 4305
ScaleWidth     = 7080
Top            = 1365
Width          = 7200
```

Begin CommandButton Command1

```
Caption        = "CLOSE"
Height         = 375
Left           = 5520
TabIndex      = 2
Top            = 3840
Width          = 1095
```

End

Begin Image Image1

```
Height        = 480
Left           = 3120
Picture       = (Icon)
Top            = 240
Width          = 480
```

End

Begin Label Label2

```
Alignment     = 2  'Center
BackColor     = &H00C0E0FF&
Caption       = "This project is initiated to fulfil
FontBold      = -1 'True
FontItalic    = 0  'False
FontName      = "MS Sans Serif"
FontSize      = 9.75
FontStrikethru = 0  'False
FontUnderline = 0  'False
Height        = 615
Left          = 240
TabIndex      = 0
Top           = 3120
Width         = 6615
```

End

Begin Label Label1

```
Alignment     = 2  'Center
BackColor     = &H00FFFF80&
Caption       = "Ero-Map was designed to conduct Soi
FontBold      = -1 'True
FontItalic    = 0  'False
FontName      = "MS Sans Serif"
```

PURPOSE.FRM - 2

```
FontSize           = 12
FontStrikethru     = 0   'False
FontUnderline      = 0   'False
ForeColor          = &H000000C0&
Height             = 2295
Left               = 240
TabIndex           = 1
Top                = 840
Width              = 6615
End
End
```

PURPOSE.FRM - 1

```
Sub Timer1_Timer ()
PURPOSE.Hide
Unload PURPOSE
End Sub
```

```
Sub Command1_Click ()
PURPOSE.Hide
Unload PURPOSE
GISMAIN.Show
End Sub
```

VERSION 2.00

Begin Form Rights

```
BackColor      = &H00C0E0FF&
BorderStyle    = 1  'Fixed Single
Caption        = "Copyright @ CGIA1996"
ClientHeight   = 4020
ClientLeft     = 1725
ClientTop      = 1860
ClientWidth    = 6540
ControlBox     = 0  'False
Height        = 4425
Left          = 1665
LinkTopic     = "Form1"
ScaleHeight    = 4020
ScaleWidth    = 6540
Top           = 1515
Width         = 6660
```

Begin CommandButton Command1

```
Caption      = "Close"
Height       = 375
Left        = 4200
TabIndex    = 2
Top         = 3480
Width       = 975
```

End

Begin Image Image1

```
Height = 480
Left   = 2760
Picture = (Icon)
Top    = 120
Width  = 480
```

End

Begin Label Label2

```
BackColor      = &H00C0E0FF&
Caption        = "Michael Tang Chuoon Mun"
FontBold       = -1  'True
FontItalic     = -1  'True
FontName       = "Times New Roman"
FontSize       = 9.75
FontStrikethru = 0  'False
FontUnderline  = 0  'False
ForeColor      = &H00FF0000&
Height        = 375
Left          = 3600
TabIndex      = 1
Top           = 3000
Width         = 2415
```

End

Begin Label Label1

```
BackColor      = &H00C0E0FF&
Caption        = "Copyright @ 1996 by MIKETCM-CGI"
FontBold       = -1  'True
FontItalic     = 0  'False
FontName       = "MS Sans Serif"
FontSize       = 9.75
FontStrikethru = 0  'False
FontUnderline  = 0  'False
ForeColor      = &H000000C0&
```

RIGHTS.FRM - 2

```
    Height      = 2415
    Left        = 120
    TabIndex    = 0
    Top         = 720
    Width       = 6255
End
End
```

RIGHTS.FRM - 1

```
Sub Command1_Click ()
Rights.Hide
Unload Rights
GISMAIN.Show
End Sub
```

VERSION 2.00

Begin Form PWForm

```
BackColor      = &H00C0E0FF&
BorderStyle    = 3  'Fixed Double
Caption        = "ERO-MAP SECURITY CHECK"
ClientHeight   = 3900
ClientLeft     = 2250
ClientTop      = 1845
ClientWidth    = 5655
ControlBox     = 0  'False
Height         = 4305
Left           = 2190
LinkTopic      = "Form2"
MaxButton      = 0  'False
MinButton      = 0  'False
ScaleHeight    = 3900
ScaleWidth     = 5655
Top            = 1500
Width          = 5775
```

Begin CommandButton Command1

```
Caption        = "OK"
FontBold       = -1  'True
FontItalic     = 0  'False
FontName       = "MS Sans Serif"
FontSize       = 9.75
FontStrikethru = 0  'False
FontUnderline  = 0  'False
Height         = 375
Left           = 3960
TabIndex      = 6
Top            = 3360
Width         = 1335
```

End

Begin TextBox pass

```
Alignment      = 2  'Center
FontBold       = -1  'True
FontItalic     = 0  'False
FontName       = "MS Sans Serif"
FontSize       = 9.75
FontStrikethru = 0  'False
FontUnderline  = 0  'False
ForeColor      = &H0000FF00&
Height         = 360
Left           = 2040
PasswordChar   = "X"
TabIndex      = 5
Top            = 3000
Width          = 1455
```

End

Begin PictureBox IconPic

```
AutoSize       = -1  'True
BackColor      = &H0080C0FF&
BorderStyle    = 0  'None
Height         = 480
Left           = 5040
Picture        = (Icon)
ScaleHeight    = 480
ScaleWidth     = 480
```

```
    TabIndex      = 1
    Top           = 1440
    Width         = 480
End
Begin PictureBox Picture1
    AutoSize      = -1 'True
    BackColor     = &H00C0E0FF&
    BorderStyle   = 0 'None
    Height        = 480
    Left          = 120
    Picture       = (Icon)
    ScaleHeight   = 480
    ScaleWidth    = 480
    TabIndex      = 0
    Top           = 1440
    Width         = 480
End
Begin Label Label3
    Alignment     = 2 'Center
    BackColor     = &H00C0E0FF&
    Caption       = "Please Enter The Security Code "
    FontBold      = -1 'True
    FontItalic    = 0 'False
    FontName      = "MS Sans Serif"
    FontSize      = 9.75
    FontStrikethru = 0 'False
    FontUnderline = 0 'False
    Height        = 375
    Left          = 600
    TabIndex      = 4
    Top           = 2400
    Width         = 4335
End
Begin Line Line2
    BorderColor   = &H00008000&
    BorderWidth   = 3
    X1            = 600
    X2            = 4920
    Y1            = 2160
    Y2            = 2160
End
Begin Line Line1
    BorderColor   = &H00008000&
    BorderWidth   = 3
    X1            = 600
    X2            = 4920
    Y1            = 1200
    Y2            = 1200
End
Begin Label Label2
    Alignment     = 2 'Center
    BackColor     = &H00C0E0FF&
    Caption       = "PASSWORD"
    FontBold      = -1 'True
    FontItalic    = 0 'False
    FontName      = "Arial"
    FontSize      = 18
    FontStrikethru = 0 'False
```

```
FontUnderline = 0 'False
ForeColor     = &H000000FF&
Height       = 495
Left         = 840
TabIndex     = 3
Top          = 1440
Width        = 3975
End
Begin Label Label1
Alignment    = 2 'Center
BackColor    = &H00C0E0FF&
Caption      = "Ero-Map Soil Erosion Modelling And
FontBold     = -1 'True
FontItalic   = 0 'False
FontName     = "MS Sans Serif"
FontSize     = 13.5
FontStrikethru = 0 'False
FontUnderline = 0 'False
ForeColor    = &H00C00000&
Height       = 855
Left         = 360
TabIndex     = 2
Top          = 240
Width        = 4935
End
End
```

PWFORM.FRM - 1

```
Sub Command1_Click ()
'change from string to numeric by using Val
Code = Val(pass.Text)

If Code = 2543969 Then
Beep
Beep
MsgBox "Welcome To Ero-Map Version 1.0", 48, "ACCESS"
PWFORM.Hide
Unload PWFORM
Cls
Load GISMain
Beep
Beep
GISMain.Show
Else
Beep
Beep
Beep
MsgBox "INVALID USER : ACCESS DENIED", 16, "WARNING"
End If

End Sub
```

```
Sub MnuLvl2Bound_Click ()
Call PMEXECUTE("ADD FEATURECLASS BLK_BDRY TO PM_DISPLAY_LIST
WINMAP")
End Sub
```

```
Sub MnuLvl2Geo_Click ()
Call PMEXECUTE("ADD FEATURECLASS GEOLOGY TO PM_DISPLAY_LIST
INMAP")
End Sub
```

```
Sub MnuLvl2Water_Click ()
Call PMEXECUTE("ADD FEATURECLASS SING_WATER TO PM_DISPLAY_LI
E WINMAP")
```

End Sub

```
Sub Form_Load ()
'Declarations
Dim SL1, SL2, SL3, SL4, SL5, SL6, SL7 As String
```

```
'Center the form
Left = (Screen.Width - Width) / 2
Top = (Screen.Height - Height) / 2
```

```
'Pre-startup procedure
bRTN = Shell("C:\EPS_PM\SAE\PMENGINE.EXE")
Call PMEXECUTE("LOGIN MAPKAWI")
Call PMEXECUTE("OPEN INSTANCE WINMAP")
Call PMSETUP("")
MAPNAME = "C:\EROMAP\MAPKAWI\LKAWI.TSF"
```

```
SL1 = ("SET WINMAP!MAP.FILENAME TO ")
SL2 = DBLEQUOTE & MAPNAME & DBLEQUOTE
```

```
Call PMEXECUTE(SL1 & SL2)
```

```
SHANDLE = Hex(GISMAIN.Picture1.hWnd)
```

```
SL3 = ("SET WINMAP!WINDOW.OWNER TO ")
SL4 = DBLEQUOTE & SHANDLE & DBLEQUOTE
Call PMEXECUTE(SL3 & SL4)
```

End Sub

```
Sub MnuLvl2Clear_Click ()
Call PMEXECUTE("REMOVE * FROM PM_DISPLAY_LIST IN INSTANCE WI
Call PMEXECUTE("DRAW * IN INSTANCE WINMAP")
End Sub
```

```
Sub MnuLvl2Cre_Click ()
'DISPLAY CREDITS FORM
GISMAIN.Hide
Load CREDITS
Beep
```

GISMAIN.FRM - 2

CREDITS.Show
End Sub

Sub MnuLvl2CRight_Click ()
'DISPLAY RIGHTS FORM
GISMAIN.Hide
Load RIGHTS
Beep
RIGHTS.Show
End Sub

Sub MnuLvl2Disp_Click ()
Call PMEXECUTE("SET WINMAP!WINDOW.VISIBLE TO TRUE")
Call PMEXECUTE("SET WINMAP!WINDOW.BACKGROUNDCOLOR TO 7")
Call PMEXECUTE("ZOOM UP 50 IN INSTANCE WINMAP")
Call PMEXECUTE("ZOOM AREA 182194.23149676 680425.8408709074 2219
639.154482578 IN INSTANCE WINMAP")
End Sub

Sub MnuLvl2Ero_Click ()
Call PMEXECUTE("REMOVE * FROM PM_DISPLAY_LIST IN INSTANCE WINMAP")
Call PMEXECUTE("ADD FEATURECLASS E0010 TO PM_DISPLAY_LIST AT ENI
MAP")
Call PMEXECUTE("ADD FEATURECLASS E100150 TO PM_DISPLAY_LIST AT E
INMAP")
Call PMEXECUTE("ADD FEATURECLASS E1050 TO PM_DISPLAY_LIST AT ENI
MAP")
Call PMEXECUTE("ADD FEATURECLASS E15000 TO PM_DISPLAY_LIST AT EN
NMAP")
Call PMEXECUTE("ADD FEATURECLASS E50100 TO PM_DISPLAY_LIST AT EN
NMAP")
End Sub

Sub MnuLvl2Exit_Click ()
Call PMEXECUTE("CLOSE INSTANCE WINMAP")
Call PMEXECUTE("LOGOUT")
'Call PMEXECUTE("DOWN")
Unload GISMAIN
GISMAIN.Hide

End Sub

Sub MnuLvl2Fresh_Click ()
Call PMEXECUTE("DRAW * IN INSTANCE WINMAP")
End Sub

Sub MnuLvl2Inst_Click ()
GISMAIN.Hide
Load HELP
HELP.Show
End Sub

Sub MnuLvl2Pur_Click ()
'DISPLAY PURPOSE FORM
GISMAIN.Hide
Load PURPOSE
Beep
PURPOSE.Show

End Sub

```
Sub MnuLvl2SysDev_Click ()
'DISPLAY SYSDEV FORM
GISMAIN.Hide
Load SYSDEV
Beep
SYSDEV.Show
End Sub
```

```
Sub MnuLvl2Zoomin_Click ()
Call PMEXECUTE("ZOOM IN INSTANCE WINMAP")
End Sub
```

```
Sub MnuLvl2Zoomout_Click ()
Call PMEXECUTE("ZOOM OUT IN INSTANCE WINMAP")
End Sub
```

```
Sub MnuLvl3C_Click ()
Call PMEXECUTE("REMOVE * FROM PM_DISPLAY_LIST IN INSTANCE WINMAP")
Call PMEXECUTE("ADD FEATURECLASS C_085 TO PM_DISPLAY_LIST AT MAP")
Call PMEXECUTE("ADD FEATURECLASS C_095 TO PM_DISPLAY_LIST AT MAP")
Call PMEXECUTE("ADD FEATURECLASS C_100 TO PM_DISPLAY_LIST AT MAP")
Call PMEXECUTE("ADD FEATURECLASS C_115 TO PM_DISPLAY_LIST AT MAP")
End Sub
```

```
Sub MnuLvl3Coast_Click ()
Call PMEXECUTE("REMOVE * FROM PM_DISPLAY_LIST IN INSTANCE WINMAP")
Call PMEXECUTE("ADD FEATURECLASS COAST TO PM_DISPLAY_LIST AT MAP")
End Sub
```

```
Sub MnuLvl3Down_Click ()
Call PMEXECUTE("ZOOM DOWN 25 IN INSTANCE WINMAP")
End Sub
```

```
Sub MnuLvl3K_Click ()
Call PMEXECUTE("REMOVE * FROM PM_DISPLAY_LIST IN INSTANCE WINMAP")
Call PMEXECUTE("ADD FEATURECLASS K50 TO PM_DISPLAY_LIST AT MAP")
Call PMEXECUTE("ADD FEATURECLASS K36 TO PM_DISPLAY_LIST AT MAP")
Call PMEXECUTE("ADD FEATURECLASS K37 TO PM_DISPLAY_LIST AT MAP")
Call PMEXECUTE("ADD FEATURECLASS K38 TO PM_DISPLAY_LIST AT MAP")
Call PMEXECUTE("ADD FEATURECLASS K39 TO PM_DISPLAY_LIST AT MAP")
Call PMEXECUTE("ADD FEATURECLASS K42 TO PM_DISPLAY_LIST AT MAP")
Call PMEXECUTE("ADD FEATURECLASS K47 TO PM_DISPLAY_LIST AT MAP")
Call PMEXECUTE("ADD FEATURECLASS K35 TO PM_DISPLAY_LIST AT MAP")
End Sub
```

```
Call PMEXECUTE("ADD FEATURECLASS K54 TO PM_DISPLAY_LIST AT END IN  
P")  
Call PMEXECUTE("ADD FEATURECLASS K57 TO PM_DISPLAY_LIST AT END IN  
P")  
Call PMEXECUTE("ADD FEATURECLASS K72 TO PM_DISPLAY_LIST AT END IN  
P")  
End Sub
```

```
Sub MnuLvl3Left_Click ()  
Call PMEXECUTE("ZOOM LEFT 25 IN INSTANCE WINMAP")  
End Sub
```

```
Sub MnuLvl3LS_Click ()  
Call PMEXECUTE("REMOVE * FROM PM_DISPLAY_LIST IN INSTANCE WINMAP")  
Call PMEXECUTE("ADD FEATURECLASS LS0001 TO PM_DISPLAY_LIST AT END  
NMAP")  
Call PMEXECUTE("ADD FEATURECLASS LS0102 TO PM_DISPLAY_LIST AT END  
NMAP")  
Call PMEXECUTE("ADD FEATURECLASS LS0205 TO PM_DISPLAY_LIST AT END  
NMAP")  
Call PMEXECUTE("ADD FEATURECLASS LS0510 TO PM_DISPLAY_LIST AT END  
NMAP")  
Call PMEXECUTE("ADD FEATURECLASS LS1020 TO PM_DISPLAY_LIST AT END  
NMAP")  
Call PMEXECUTE("ADD FEATURECLASS LS2030 TO PM_DISPLAY_LIST AT END  
NMAP")  
Call PMEXECUTE("ADD FEATURECLASS LS3000 TO PM_DISPLAY_LIST AT END  
NMAP")  
End Sub
```

```
Sub MnuLvl3P_Click ()  
Call PMEXECUTE("REMOVE * FROM PM_DISPLAY_LIST IN INSTANCE WINMAP")  
Call PMEXECUTE("ADD FEATURECLASS P_07 TO PM_DISPLAY_LIST AT END IN  
AP")  
Call PMEXECUTE("ADD FEATURECLASS P_08 TO PM_DISPLAY_LIST AT END IN  
AP")  
Call PMEXECUTE("ADD FEATURECLASS P_09 TO PM_DISPLAY_LIST AT END IN  
AP")  
Call PMEXECUTE("ADD FEATURECLASS P_10 TO PM_DISPLAY_LIST AT END IN  
AP")  
End Sub
```

```
Sub MnuLvl3Rain_Click ()  
Call PMEXECUTE("REMOVE * FROM PM_DISPLAY_LIST IN INSTANCE WINMAP")  
Call PMEXECUTE("ADD FEATURECLASS R2185 TO PM_DISPLAY_LIST AT END I  
MAP")  
Call PMEXECUTE("ADD FEATURECLASS R2250 TO PM_DISPLAY_LIST AT END I  
MAP")  
Call PMEXECUTE("ADD FEATURECLASS R2350 TO PM_DISPLAY_LIST AT END I  
MAP")  
Call PMEXECUTE("ADD FEATURECLASS R2450 TO PM_DISPLAY_LIST AT END I  
MAP")  
Call PMEXECUTE("ADD FEATURECLASS R2550 TO PM_DISPLAY_LIST AT END I  
MAP")  
Call PMEXECUTE("ADD FEATURECLASS R2650 TO PM_DISPLAY_LIST AT END I  
MAP")  
Call PMEXECUTE("ADD FEATURECLASS R2750 TO PM_DISPLAY_LIST AT END I  
MAP")
```

GISMAIN.FRM - 5

```
Call PMEXECUTE("ADD FEATURECLASS R2850 TO PM_DISPLAY_LIST AT END  
MAP")
```

```
End Sub
```

```
Sub MnuLvl3Right_Click ()
```

```
Call PMEXECUTE("ZOOM RIGHT 25 IN INSTANCE WINMAP")
```

```
End Sub
```

```
Sub MnuLvl3Up_Click ()
```

```
Call PMEXECUTE("ZOOM UP 25 IN INSTANCE WINMAP")
```

```
End Sub
```

EROEXEC.BAS - 1

```
Sub PMEXECUTE (S2QL_COMMAND As String)
```

```
GISMAIN.Text1.LinkItem = "PMENGINE"
```

```
GISMAIN.Text1.LinkTopic = "PMENGINE|S2QL"
```

```
GISMAIN.Text1.LinkMode = 2
```

```
GISMAIN.Text1.LINKTIMEOUT = 25000
```

```
GISMAIN.Text1.LinkExecute S2QL_COMMAND
```

```
Exit Sub
```

```
End Sub
```

EROSSETUP.BAS - 1

```
Sub PMSETUP (SVALUE As String)
```

```
Call PMEXECUTE("SET WINMAP!WINDOW.BUTTONBAR TO FALSE")
```

```
End Sub
```

CROP.FRM - 1

```
Sub Command1_Click ()
CODE = Val(TEXT1.Text)
If CODE = 1 Then
Beep
Beep
MsgBox "C FACTOR SECURED", 48, "LAYER INTERROGATOR"
CROP.Hide
Unload CROP
Cls
Load PCONS
Beep
Beep
PCONS.Show
Else
Beep
MsgBox "INITIATE DATABASE BUILDER", 16, "WARNING"
CROP.Hide
Unload CROP
End If
End Sub
```

LAYER.FRM - 1

```
Sub Command1_Click ()
CODE = Val(SCRCHK.Text)
If CODE = 2543969 Then
Beep
Beep
MsgBox "WELCOME LAYER-INTERROGATOR", 48, "ACCESS"
LAYER.Hide
Unload LAYER
Cls
Load Rain
Beep
Beep
Rain.Show
Else
Beep
Beep
MsgBox "INVALID USER", 16, "WARNING"
Cls
LAYER.Hide
LAYER.Show
End If
End Sub
```

KSOIL.FRM - 1

```
Sub Command1_Click ()
CODE = Val(TEXT1.Text)
If CODE = 1 Then
Beep
Beep
MsgBox "K FACTOR SECURED", 48, "LAYER INTERROGATOR"
Beep
Beep
Beep
MsgBox "PROCEED TO EROMAP LAYER ANALYZER", 48, "ACCESS"
KSOIL.Hide
Unload KSOIL
Cls
'Load PWF'ORM

Else
Beep
MsgBox "INITIATE DATABASE BUILDER", 16, "WARNING"
KSOIL.Hide
Unload KSOIL
End If
End Sub
```

PCONS.FRM - 1

```
Sub Command1_Click ()
CODE = Val(TEXT1.Text)
If CODE = 1 Then
Beep
Beep
MsgBox "P FACTOR SECURED", 48, "LAYER INTERROGATOR"
PCONS.Hide
Unload PCONS
Cls
Load KSOIL
Beep
Beep
KSOIL.Show
Else
Beep
MsgBox "INITIATE DATABASE BUILDER", 16, "WARNING"
PCONS.Hide
Unload PCONS
End If
End Sub
```

LS.FRM - 1

```
Sub Command1_Click ()
CODE = Val(TEXT1.Text)
If CODE = 1 Then
Beep
Beep
MsgBox "LS FACTOR SECURED", 48, "LAYER INTERROGATOR"
LS.Hide
Unload LS
Cls
Load CROP
Beep
Beep
CROP.Show
Else
MsgBox "INITIATE DATABASE BUILDER", 16, "WARNING"
LS.Hide
Unload LS
End If
End Sub
```

RAIN.FRM - 1

```
Sub Command1_Click ()
code = Val(text1.Text)
If code = 1 Then
Beep
Beep
MsgBox "RAINFALL FACTOR SECURED", 48, "LAYER INTERROGATOR"
RAIN.Hide
Unload RAIN
Cls
Load LS
Beep
Beep
LS.Show
Else
Beep
Beep
MsgBox "INITIATE DATABASE BUILDER", 16, "WARNING"
RAIN.Hide
Unload RAIN
End If

End Sub
```

VERSION 2.00

Begin Form Sysdev

```
BackColor      = &H00C0E0FF&
BorderStyle    = 1  'Fixed Single
Caption        = "Ero-Map System Developer"
ClientHeight   = 3540
ClientLeft     = 1425
ClientTop      = 1785
ClientWidth    = 6840
ControlBox     = 0  'False
ForeColor      = &H00000000&
Height         = 3945
Left           = 1365
LinkTopic      = "Form2"
MaxButton      = 0  'False
MinButton      = 0  'False
ScaleHeight    = 3540
ScaleWidth     = 6840
Top            = 1440
Width          = 6960
```

Begin CommandButton Command1

```
Caption        = "Close"
FontBold       = -1  'True
FontItalic     = 0  'False
FontName       = "Times New Roman"
FontSize       = 12
FontStrikethru = 0  'False
FontUnderline  = 0  'False
Height         = 375
Left           = 5400
TabIndex       = 5
Top            = 3000
Width          = 1095
```

End

Begin Line Line2

```
BorderColor    = &H0000FF00&
BorderWidth    = 2
X1              = 360
X2              = 6360
Y1              = 360
Y2              = 360
```

End

Begin Line Line1

```
BorderColor    = &H0000C000&
BorderWidth    = 2
X1              = 360
X2              = 6360
Y1              = 720
Y2              = 720
```

End

Begin Image Image2

```
Height         = 480
Left           = 3120
Picture        = (Icon)
Top            = 1200
Width          = 480
```

End

Begin Image Image1

```
      Height      = 480
      Left        = 2880
      Picture     = (Icon)
      Top         = 840
      Width       = 480
End
Begin Label Label5
  BackColor      = &H00C0E0FF&
  Caption       = "Associate Professor Dr. Taher Buyong"
  FontBold      = -1 'True
  FontItalic    = -1 'True
  FontName      = "Times New Roman"
  FontSize      = 13.5
  FontStrikethru = 0 'False
  FontUnderline = 0 'False
  ForeColor     = &H00000000&
  Height       = 495
  Left         = 2280
  TabIndex     = 4
  Top         = 2400
  Width       = 4455
End
Begin Label Label4
  BackColor      = &H00C0E0FF&
  Caption       = "Advisor"
  FontBold      = -1 'True
  FontItalic    = -1 'True
  FontName      = "Times New Roman"
  FontSize      = 13.5
  FontStrikethru = 0 'False
  FontUnderline = 0 'False
  ForeColor     = &H00FF0000&
  Height       = 375
  Left         = 600
  TabIndex     = 3
  Top         = 2400
  Width       = 1215
End
Begin Label Label3
  BackColor      = &H00C0E0FF&
  Caption       = "Michael Tang Chuoon Mun"
  FontBold      = -1 'True
  FontItalic    = -1 'True
  FontName      = "Times New Roman"
  FontSize      = 13.5
  FontStrikethru = 0 'False
  FontUnderline = 0 'False
  Height       = 495
  Left         = 2280
  TabIndex     = 2
  Top         = 1920
  Width       = 4215
End
Begin Label Label2
  Alignment     = 2 'Center
  BackColor     = &H00C0E0FF&
  Caption       = "Developer"
  FontBold     = -1 'True
```

VERSION 2.00

Begin Form CROP

```
BackColor      =  &H00C0E0FF&
BorderStyle    =  1  'Fixed Single
Caption        =  "LAYER INTERROGATOR (CROP FACTOR)"
ClientHeight   =  3045
ClientLeft     =  1995
ClientTop      =  1950
ClientWidth    =  5850
Height         =  3450
Left           =  1935
LinkTopic      =  "Form2"
MaxButton      =  0  'False
MinButton      =  0  'False
MousePointer   =  2  'Cross
ScaleHeight    =  3045
ScaleWidth     =  5850
Top            =  1605
Width          =  5970
```

Begin CommandButton Command1

```
Caption        =  "OK"
Height         =  375
Left           =  4200
TabIndex      =  3
Top            =  2520
Width         =  975
```

End

Begin TextBox Text1

```
Alignment      =  2  'Center
FontBold       =  -1  'True
FontItalic     =  0  'False
FontName       =  "MS Sans Serif"
FontSize       =  12
FontStrikethru =  0  'False
FontUnderline  =  0  'False
Height         =  420
Left           =  2280
TabIndex      =  2
Top            =  2280
Width         =  735
```

End

Begin Label Label2

```
Alignment      =  2  'Center
BackColor      =  &H000000FF&
Caption        =  "YES(1) / NO(2)"
FontBold       =  -1  'True
FontItalic     =  0  'False
FontName       =  "MS Sans Serif"
FontSize       =  12
FontStrikethru =  0  'False
FontUnderline  =  0  'False
ForeColor      =  &H00FF0000&
Height         =  375
Left           =  1680
TabIndex      =  1
Top            =  1680
Width         =  2175
```

End

CROP.FRM - 2

```
Begin Label Label1
  Alignment      = 2 'Center
  BackColor     = &H00C0E0FF&
  Caption       = "DO YOU HAVE THE C FACTOR ?"
  FontBold      = -1 'True
  FontItalic    = 0 'False
  FontName      = "MS Sans Serif"
  FontSize     = 18
  FontStrikethru = 0 'False
  FontUnderline = 0 'False
  ForeColor     = &H00FF00FF&
  Height       = 975
  Left         = 840
  TabIndex     = 0
  Top          = 600
  Width        = 4095
End
Begin Image Image1
  Height = 480
  Left   = 2640
  Picture = (Icon)
  Top    = 120
  Width  = 480
End
End
```

SYSDEV.FRM - 1

```
Sub Command1_Click ()
'End display
Sysdev.Hide
Unload Sysdev
GISMAIN.Show
End Sub
```