

**WIDEBAND MICROSTRIP ANTENNA FOR LAND BASED  
VEHICLES**

**(ANTENNA JALURMIKRO BERJALUR FREKUENSI LEBAR  
UNTUK KEGUNAAN KENDERAAN DARAT)**

**ASSOCIATE PROFESSOR Ir. Dr. WAN KHAIRUDDIN WAN ALI**

**RESEARCH VOT: 74038**

**Jabatan Aeronautik dan Automotif**

**Fakulti Kejuruteraan Mekanikal**

**Universiti Teknologi Malaysia**

October 2004

## **ACKNOWLEDGMENT**

On behalf of research project, I would like to acknowledge the financial support that this project has received (Project Vot: 74038) from The Ministry of Science, Technology and Environmental (MOSTE) under The Intensification Research on Priority Area (IRPA). Without with, this project will not meet the successful completion.

I greatly appreciated to Mr. Nasarudin Ismail, head of Automotive at Laboratory for allowing this project to use the room and facility at his laboratory. Finally I would like to extend my gratitude to all staff at Jabatan Aeronautik dan Automotif, laboratory technicians and the staff of Research Management Center who involved in assisting this project.

**ABSTARCT****WIDEBAND MICROSTRIP ANTENNA FOR LAND BASED  
VEHICLES**

*(Keywords: Wideband Microstrip Antenna, Wideband Antenna, Microstrip Antenna,  
Microstrip, Antenna)*

The objective of this project is to design, construct and fabricate microstrip antennas suitable for land based vehicles application centered at 2.4GHz. The antenna must operate within the unlicensed 2.4GHz band. This band is currently being used for the IEEE 802.11b and g standard and other industrial, medical and scientific applications. The antenna is proposed to be used as a transmitting as well as receiving antenna in wireless LANs and the mentioned applications. A rectangular microstrip prototype antenna was produced, with the bandwidth of 7.8 percent. The antenna covers the 2.4GHz band for wireless LAN with the bandwidth from 2.33GHz to 2.52 GHz. The antenna was fabricated on woven fiberglass substrate, that had a relative dielectric constant,  $\epsilon_r = 4.88$ , a loss tangent  $\tan \delta = 0.001$  and thickness, h of 1.57 mm.

**Key researcher:**

**Prof. Madya Wan Khairuddin Wan Ali**

**Email: [wankhai@fkm.utm.my](mailto:wankhai@fkm.utm.my)**

**Tel. No. : 07-5534719**

**Vote No. : 74038**

## ABSTRAK

Projek ini bertujuan untuk merekabentuk dan membina antenna jalurmikro yang boleh digunakan untuk kenderaan darat. Antenna tersebut beroperasi dalam frekuensi 2.4 GHz yang digunakan untuk standard LAN, iaitu IEEE 802.11b dan g dan juga didalam aplikasi – aplikasi industri, perubatan dan saintifik.. Antenna dicadangkan untuk digunakan sebagai antenna pemancar dan juga penerima untuk aplikasi – aplikasi tersebut. Akhirnya, sebuah antenna jalurmikro prototip yang berbentuk segiempat tepat telah dihasilkan. Lebar jalur antenna ini ialah 7.8 peratus dan beroperasi di antara 2.33 GHz dan 2.52 GHz. Antenna tersebut dibina pada substrate gentian kaca yang mempunyai  $\epsilon_r = 4.88$ ,  $\tan \delta = 0.001$  dan ketebalan,  $h$  of 1.57 mm.

## TABLE OF CONTENTS

CHAPTER	TOPIC	PAGE
	<b>ACKNOWLEDGEMENTS</b>	<b>i</b>
	<b>ABSTRACT</b>	<b>ii</b>
	<b>ABSTRAK</b>	<b>iii</b>
	<b>TABLE OF CONTENTS</b>	<b>iv</b>
	<b>LIST OF FIGURES</b>	<b>vii</b>
	<b>LIST OF APPENDICES</b>	<b>x</b>
<b>CHAPTER I</b>	<b>INTRODUCTION</b>	
	1.1 Objective 1.2 Scopes	2
		<b>1</b>
<b>CHAPTER II</b>	<b>MICROSTRIP ANTENNA</b>	<b>3</b>
	2.1 Introducing The Microstrip Antenna	3
	2.2 General Description	4
	2.2.1 Conducting Layers	5
	2.2.2 Dielectric Substrate	5
	2.2.3 Configurations	7
	2.2.4 Microstrip Feeds	7
	2.2.5 Losses in Microstrip	9
	2.3 Bandwidth	10
	2.4 Polarization	11
	2.5 Radiation field	13

2.5.1 Radiation Mechanism of A Microstrip Antenna	13
2.6 Commercial Applications for Microstrip Antennas	15
2.6.1 Mobile Satellite Communications	15
2.6.2 Global Positioning System	15
2.6.3 Direct Broadcast Satellite System	16
2.6.4 Non-Satellite Based Applications	17
<b>CHAPTER III</b>	<b>18</b>
<b>WIRELESS LOCAL AREA NETWORK</b>	
3.1 Background	18
3.2 What is Wireless LAN?	19
3.3 Wireless LAN Applications	20
3.3.1 Healthcare 3.3.2 Education	20
3.3.2 Education	21
3.3.3 Inventory	21
3.4 Wireless LAN Configurations	22
3.5 Wireless LAN Technology Options	24
3.5.1 Radio-Based Wireless LAN	24
3.5.1.1 Medium Access Control	25
3.5.1.2 Spread Spectrum Modulation	26
3.5.2 Infrared	28
3.6 IEEE 802.11 Standard	29
3.6.1 IEEE 802.11b	30
3.6.2 IEEE 802.11 a	30
3.6.3 IEEE 802.11 g	31
3.7 Wireless LAN Security 3.8 Bluetooth	32
3.8 Bluetooth	33
<b>CHAPTER IV</b>	<b>34</b>
<b>ANTENNAS FOR WIRELESS LAN</b>	
4.1 Characteristics For Wireless LAN Antennas 4.1.1	35
Frequency	35
4.1.2 Power	35
4.1.3 Radiation Pattern	36

4.1.4 Gain	37	
<b>CHAPTER V</b>	<b>RECTANGULAR MICROSTRIP ANTENNA</b>	<b>39</b>
5.1 Introduction	39	
5.2 Resonant Frequency	39	
5.3 Design Procedure	42	
<b>CHAPTER VI</b>	<b>TRIANGULAR AND PENTAGONAL MICROSTRIP ANTENNAS</b>	<b>43</b>
6.1 Triangular Microstrip Antenna	43	
6.1.1 Correction Factors	44	
6.1.1.1 Garg and Long	44	
6.1.1.2 Dahele and Lee	45	
6.1.1.3 Gang	46	
6.1.1.4 Gurney	47	
6.3 Pentagonal Microstrip Antenna	47	
<b>CHAPTER VII</b>	<b>DESIGN PROCESS AND FABRICATION</b>	<b>49</b>
7.1 Design Methodology	49	
7.2 The Design	51	
7.2.1 Rectangular Patch	51	
7.2.2 Modification of The Rectangular Antenna	52	
7.2.3 The Pentagonal Patch	53	
7.3 Fabrication	60	
<b>CHAPTER VIII</b>	<b>EXPERIMENTAL RESULTS</b>	<b>62</b>
8.1 Return Loss Measurement	62	
8.2 Results for The Fabricated Antennas	63	
8.2.1 Rectangular Antennas	64	
8.2.2 Pentagonal Patch	64	
8.3 Discussions	68	

<b>CHAPTER IX</b>	<b>DESIGN CORRECTION AND RESULTS</b>	<b>69</b>
9.1	The Corrected Design	69
9.1.1	Results	71
9.1.2	Repeatability Test	76
9.2	Polar Measurement	76
9.2.1	Patch A	78
<b>CHAPTER X</b>	<b>CONCLUSIONS</b>	<b>80</b>
10.1	Conclusions	80
10.2	Suggestions For Further Work	81
<b>REFERENCES</b>		<b>82</b>
<b>APPENDIX A</b>		<b>84</b>



## LIST OF FIGURES

<b>FIGURE NO.</b>	<b>TITLE</b>	<b>PAGE</b>
Figure 2.1	Rectangular microstrip antenna	4
Figure 2.2	Some Shapes of a Microstrip Antenna	7
Figure 2.3	Coaxial feed	8
Figure 2.4	Microstrip feed line	9
Figure 2.5	Aperture coupling feed	9
Figure 2.6	Linear polarizations	11
Figure 2.7	Elliptical polarizations	12
Figure 2.8	Circular polarizations	12
Figure 2.9	(a) Rectangular microstrip antenna; (b) Side View; (c) Top View	14
Figure 3.1	Independent WLAN	23
Figure 3.2	Infrastructure WLAN Provides Continuous Network Connectivity	24
Figure 3.3	The Operation of The Carrier Sense Protocol	26
Figure 3.4	Frequency Hopping Spread Spectrum	27
Figure 3.5	Direct-Sequence Spread Spectrum	28
Figure 4.1	Omni-directional Antenna Radiation	37
Figure 4.2	Directional Antenna Radiation	37
Figure 5.1	Cavity Model of A Rectangular Microstrip Antenna	40
Figure 6.1	The triangular microstrip antenna	43
Figure 6.2	Equivalent areas	45
Figure 6.3	Geometry of a Pentagonal Patch	48

Figure 6.4	Pentagonal Patch for Producing Circularly Polarized Field	48
Figure 7.1	Design Process Flow Chart	50
Figure 7.2	The Rectangular Patch	51
Figure 7.3	Return loss vs Frequency for Calculated Rectangular Patch using Computer Simulation	55
Figure 7.4	Configurations of the Modified Antenna	53
Figure 7.5	Return Loss vs Frequency for Rectangular a	56
Figure 7.6	Return Loss vs Frequency for Rectangular b	57
Figure 7.7	Comparison of Return Loss vs Frequency for Rectangular a and b	58
Figure 7.8	The Pentagonal Patch	54
Figure 7.9	Return Loss vs Frequency for Pentagonal Patch	59
Figure 8.1	Return and Loss Measurement Set-up	62
Figure 8.2	Calibration Set-up	63
Figure 8.3	Comparison of Return loss vs Frequency For Rectangular a	65
Figure 8.4	Comparison of Return loss vs Frequency For Rectangular b	66
Figure 8.5	Comparison of Return loss vs Frequency For Pentagonal Patch	67
Figure 9.1	The Corrected Antennas	70
Figure 9.2	Return Loss vs Frequency for Patch A in Computer Simulation	72
Figure 9.3	Return Loss vs Frequency for Patch b in Computer Simulation	73
Figure 9.4	Comparison of Return Loss vs Frequency for Patch A	74
Figure 9.5	Comparison of Return Loss vs Frequency for Patch B	75
Figure 9.6	Comparison of Return Loss vs Frequency in Repeatability Test	77
Figure 9.7	Set-up for Polar Pattern Measurements	78
Figure 9.8	H-plane Polar Pattern for Patch A	79

**LIST OF APPENDICES**

<b>APPENDIX</b>	<b>TITLE</b>	<b>PAGE</b>
<b>A</b>	<b>Photos</b>	<b>84</b>

# **CHAPTER I**

## **INTRODUCTION**

Wireless Networking has all the makings of an explosive technology, huge growth, a multiple and expanding uses, industry standardization, and global standardization. The release of the 802.11b standard products in late 1999 and 2000 from several prominent network equipment and wireless vendors, including Cisco, Intel, Nokia, and Ericsson, drove wireless Local Area Network (LAN) gear into wider acceptance. The market will continue to grow as vendors unveil new products with higher speeds, increased interoperability, and lower prices.

These applications do not limit to the fix users but have involved mobile user. It is expected that wireless data and voice communication will continue to evolve around land based vehicles. A mixture of mechanical and electrical efficient antenna will be required to cater for these evolutions.

In wireless LAN, that uses free space as a propagation medium, the antenna is an essential device. Designed to radiate a guided wave into free space and also to receive a wave in free space and then convert it into a guided wave, antenna can be considered as a transducer between free space and transmission line. One particular antenna is the microstrip antenna. Microstrip antenna is a printed circuit antenna, thus it is lightweight and can be made conformal to the body of host object. These properties also essential for the land based vehicles as it can retain the aerodynamic efficiency if proper designed. In the case of wireless LAN applications, microstrip antenna is also chosen mainly because of it is rugged and easily integrated with the surroundings without major alterations.

## **1.1 Objective**

To develop a wideband microstrip antenna that can be used in land-based vehicle such as in automotive.

## **1.2 Scopes**

This project was divided into of two parts, A and B, for smooth running. The scopes for each part are stated as follow:

### **1) PART A**

- I. Study on microstrip antenna.
- II. Study on wireless LAN.
- III. Find out step-by-step method to design a microstrip antenna.
- IV. Choose the suitable shape of the microstrip antenna.

### **2) PART B**

- I. Design and fabricate the antenna.
- II. Carry out all the necessary testing on the fabricated antenna.

## **CHAPTER II**

### **MICROSTRIP ANTENNA**

#### **2.1 Introducing the Microstrip Antenna**

Microstrip antenna is a printed type of antenna consisting of a dielectric substrate sandwiched in between a ground plane and a patch. The concept of microstrip antenna was first proposed in 1953, twenty years before the practical antennas were produced. Since the first practical antennas were developed in early 1970's, interest in this kind of antenna increase and in 1979 the first professional meeting on microstrip antennas was held in New Mexico. The microstrip antenna is physically very simple and flat, these are two of the reasons for the great interest in this type of antenna.

Microstrip antennas have several advantages compared to other bulky type of antennas. Some of the main advantages of microstrip antennas are that it has low fabrication cost, its lightweight, low volume, and low profile configurations that it can be made conformal, it can be easily be mounted on rockets, missiles and satellites without major modifications and arrays of these antennas can simply be produced. However, microstrip antennas have some drawbacks including narrow bandwidth, low power handling capability and low gain. But with technology

advancement and extensive research into this area these problems are being gradually overcome.

In many practical designs, the advantages of microstrip antennas far outweigh their disadvantages. With continuing research and development it is expected that microstrip antennas will replace conventional antennas for most applications. Some of the notable applications for microstrip antennas are in the areas of mobile satellite communications, the Direct Broadcast Satellite (DBS) system and Global Positioning System (GPS). Microstrip antennas also found useful in nonsatellite-based application such as remote sensing and medical hypertermia application.

## 2.2 General Description

In its simplest form, microstrip antenna is a dielectric substrate panel sandwiched in between two conductors. The lower conductor is called ground plane and the upper conductor is known as patch. Microstrip antenna is commonly used at frequencies from 1 to 100 GHz and at frequencies below *ultra high frequency*, UHF microstrip patch become exceptionally large. The radiating patch can be design in various shapes according to the desired characteristics. Illustrated in Figure 2.1 is the simplest structure of a rectangular microstrip patch antenna.

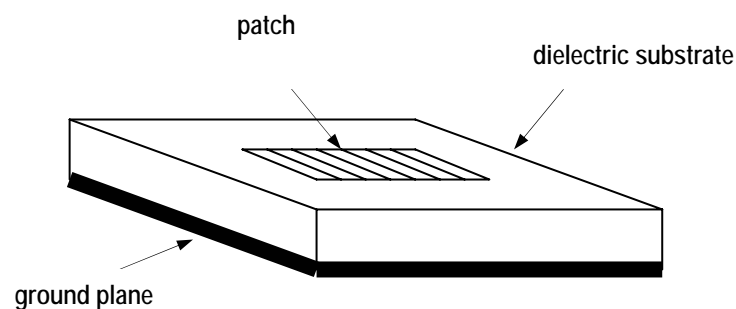

**Figure 2.1 Rectngular Microstrip Antenna**

### **2.2.1 Conducting Layers**

The common materials used for conducting surfaces are copper foil or copper foil plated with corrosion resistant metals like gold, tin and nickel. These metals are the main choice because of their low resistivity, resistant to oxidation, solderable, and adhere well to substrate.

An alternative to metal for conducting surface is to use conductive ink. It is easier to fabricate but have three disadvantages. First, is that conductive inks cannot be soldered in the usual way, to overcome this solder pastes are used. Secondly is oxidation, but the effect is negligible since the oxide is also conductive. The third is the problem of silver ion migration. Silver ions tend to migrate under humid conditions and this will cause a short across the conductive ink lines.

### **2.2.2 Dielectric Substrate**

The first step in designing microstrip antenna is to choose the suitable substrate. There are various types of substrate available in market that provides considerable flexibility in the choice of a substrate for particular applications.

In most cases, considerations in substrate characteristics involved the dielectric constant and loss tangent and their variation with temperature and frequency, dimensional stability with processing, homogeneity and isotropicity. In order to provide support and protection for the patch elements, the dielectric substrate must be strong and able to endure high temperature during soldering process and has high resistant towards chemicals that are used in fabrication process.

The surface of the substrate has to be smooth to reduce losses and adhere well to the metal used. Substrate thickness and permittivity determine the electrical



characteristics of the antenna. Thicker substrate will increase the bandwidth but it will cause the surface waves to propagate and spurious coupling will happen. This problem however, can be reduced or avoided by using a suitably low permittivity substrate. Below are six categories of dielectric material that are used for substrates.

(1) Ceramic – Alumina ( $\epsilon_r = 9.5$ ,  $\tan \delta = 0.0003$ )

This type of dielectric has low loss but brittle. It has high frequency applications and also has excellent resistance against chemicals. The temperature range for alumina is up to 1600°C.

(2) Synthetic materials – Teflon ( $\epsilon_r = 2.08$ ,  $\tan \delta = 0.0004$ )

This material possesses good electric properties but have a low melting point and have poor adhesion. The dimensional stability for this substrate is relatively poor but reinforcement with glass or ceramic will improve the dimensional stability to fairly good.

(3) Composite materials – Duroid ( $\epsilon_r = 2.2 / 6.0 / 10.8$ ,  $\tan \delta = 0.0017$ )

Composite materials are a mixture of fibreglass and the synthetic materials cited above. These materials have good electrical and physical properties and excellent dimensional stability.

(4) Ferrimagnetic – Ferrite ( $\epsilon_r = 9 - 16$ ,  $\tan \delta = 0.001$ )

This type of dielectric is biased by an electrical field. The resonant frequency of the antenna depends upon the biasing; hence magnetically tuneable antennas are possible.

(5) Semiconductor – Silicon ( $\epsilon_r = 11.9$ ,  $\tan \delta = 0.0004$ )

This type of dielectric can be integrated into circuit, but only small areas are available so it is not suitable for antenna applications.

(6) Fibreglass – Woven fibreglass ( $\epsilon_r = 4.882$ ,  $\tan \delta = 0.002$ )

This material is relatively low in cost for such low loss tangent. However, woven fibres tend to be anisotropic and this is undesirable in many designs.

### 2.2.3 Configurations

Since the early development of microstrip antenna until now, a variety of configurations have been produced and investigated to improve the performance of microstrip antenna. Some of the common shapes are rectangle, triangle and circular. Several shapes such as pentagon and ellipse are known to give circular polarization. Instead of using just one patch, microstrip antenna has been combined in many ways to improve the antenna characteristics.

By arranging patches side by side on the same substrate to produce a flat array for example will give higher directivity and gain. A wider bandwidth can be achieved if antennas are stacked on top of each one another with gaps in between. Shown in Figure 2.2 below are some of the shapes that have been investigated for microstrip patch.

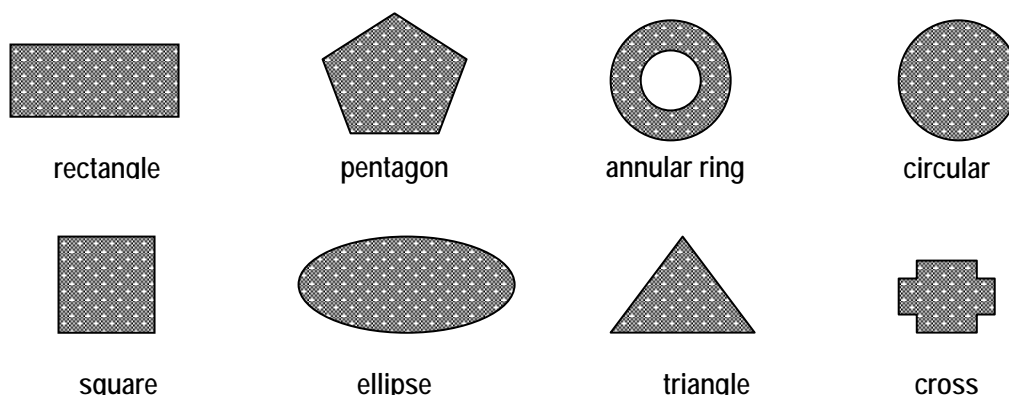

**Figure 2.2 Some Shapes of a Microstrip Antenna**

### 2.2.4 Microstrip Feeds

Matching is usually required between the antenna and the feed line, because antenna input impedances differ from customary 50ohm line impedance [1]. An

appropriately selected port location will provide matching between the antenna and its feed line. And the location of the feed line also affects the radiation characteristics. There are three common techniques for exciting a particular microstrip antenna. These are coaxial probe, microstripline and aperture coupling.

The coaxial probe is the most popular technique and is illustrated in Figure 2.3. The coaxial connector is attached to the ground plane and the coaxial center conductor extends through the substrate and is attached to the radiating patch. For coaxial probe the location of the feed is normally located at one third of the distance from the center of the patch to the side. The advantages of this method are that the probe location can selectively excite additional modes and it can be use with plated vias for multilayer circuits.

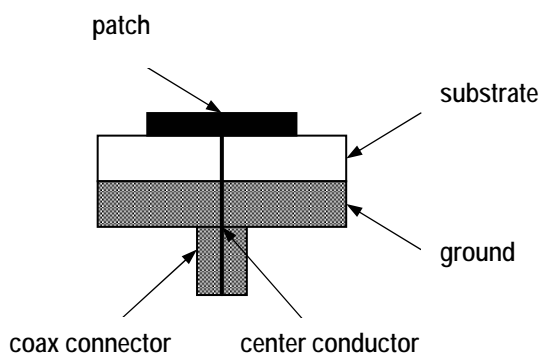

**Figure 2.3 Coaxial feed**

In the second technique, microstripline is connected directly to the radiating patch; *see* Figure 2.4. The location of the feed line may affect a small shift in resonant frequency, due to the change in coupling between the feed line and the antenna. This technique provide good polarization however, it is very difficult to minimize the spurious radiation from the microstripline. Spurious radiation will increase sidelobes on the radiating pattern.

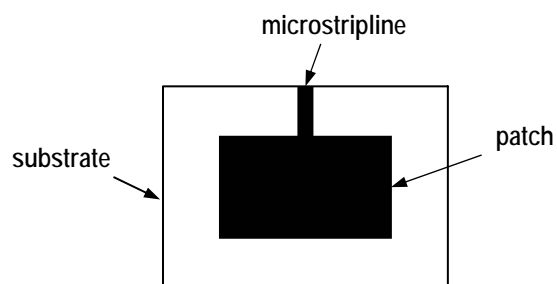

**Figure 2.4 Microstrip line feed**

In the aperture coupling the feed line and the patch are on different sides of the ground plane as shown in Figure 2.5. A slot is cut in the ground plane to couple the electromagnetic to the radiating patch, thus no via connectors needed. This technique is to avoid spurious radiation escapes from the feed line and corrupt the sidelobes or polarization of the antenna.

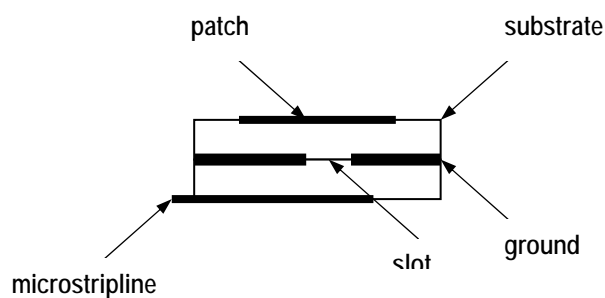

**Figure 2.5 Aperture coupling feed**

### 2.2.5 Losses in Microstrip

The dissipative losses associated with microstrip lines are one of the major limitations with the microstrip antenna [2]. That is why it is important to find new ways to reduce this loss without jeopardizing the geometrical simplicity of an antenna.

There are three types of microstrip line losses; these are ohmic loss, dielectric loss and radiation loss. The ohmic loss is caused by the finite conductivity of the metal forming the circuit. The dielectric loss is a measure of the energy dissipated within the substrate. Power loss is due to radiation occurs at discontinuities in the microstrip such as open ends, splitters and impedance steps.

## 2.2 Bandwidth

Antenna bandwidth is basically the range of frequencies over which essential performance parameters are satisfactory. There is no unique definition for satisfactory performance and this will differ from application to application. With  $f_A$  and  $f_B$  be the upper and lower frequencies for which satisfactory performance is obtained. And  $f_C$  is the center frequency (or sometimes the design frequency). Then bandwidth as a percent of the center frequency, represented as  $B_{\%}$  is given by

$$B_{\%} = \frac{f_A - f_B}{f_C} \times 100\% \quad (2.1)$$

Bandwidth is also can be defined as a ratio by

$$B_R = \frac{f_A}{f_B} \quad (2.2)$$

The second equation is used for wideband antennas, where bandwidth is expressed in ratio. Microstrip antenna is categorized as narrowband antenna, and the bandwidth is usually expressed as a percent using Equation 2.5. Antenna with  $f_A/f_B = 2$  or more is classified as broadband antenna [3].

## 2.4 Polarization

*The polarization of an antenna* in a given direction from the antenna is the polarization of the wave transmitted by the antenna [4]. The polarization in a given direction is that of the local plane wave at points on a radiation sphere centered on the antenna. Thus, polarization is that of what the wave is radiated when the antenna is transmitting. Most antennas are reciprocal, and the transmitting and receiving polarization properties are identical.

There are three most common antenna polarization, linear polarization, elliptical polarization and circular polarization. Linearly polarization is achieved when electric field vector,  $\xi$  moves back and forth along a line; *see* Figure 2.6. A general elliptical polarization is as shown in Figure 2.7a and 2.7b. The wave that produced elliptical polarization is travelling in the  $+z$ -direction, with rotation can be either to the left or right. If it rotates counter-clockwise, it is right-hand polarized. Circularly polarized (Figure 2.8a and 2.8b) is produced when electric field vector remains constant with length but rotates around a circular path, the rotation can be either to the left or to the right.

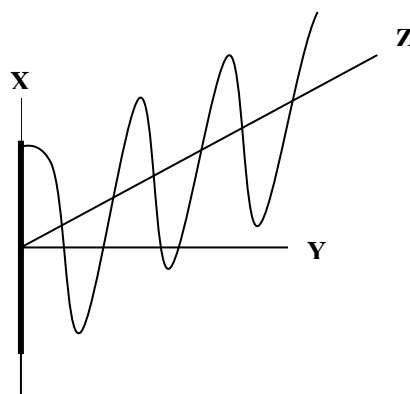

**Figure 2.6 Linear polarizations**

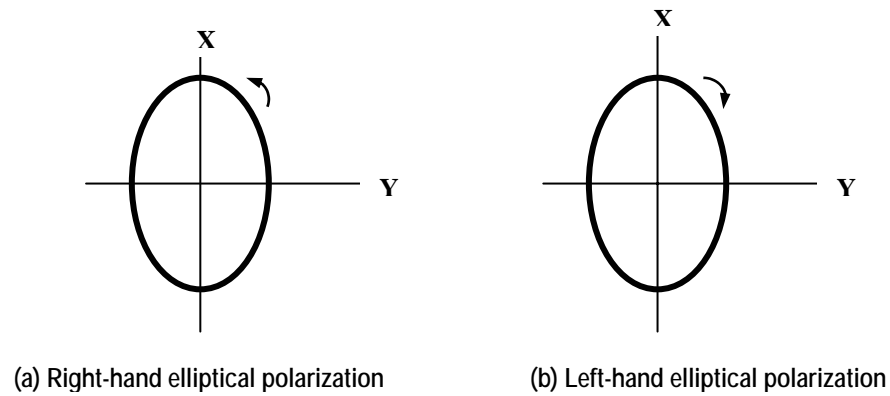

**Figure 2.7 Elliptical polarizations**

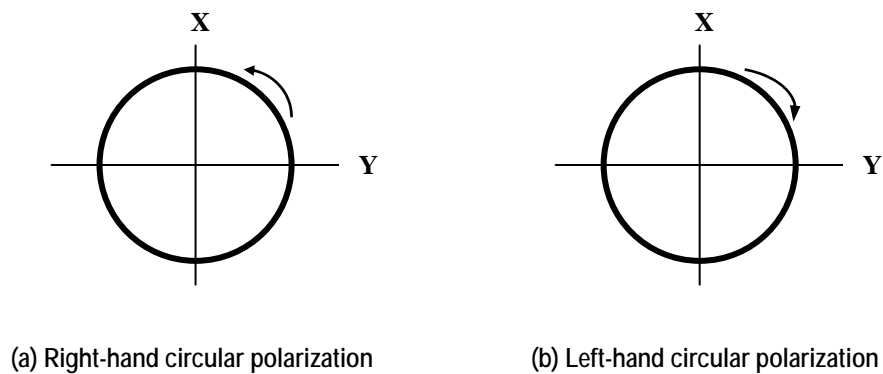

**Figure 2.8 Circular polarizations**

The polarization of a simple microstrip antenna such as rectangular and circular patch is normally linear. However, for corner feeding rectangular patch, circular polarization may be obtained with a single excitation. Circular polarization may be obtained also in circular patch by exciting two orthogonal modes of the antenna with signals  $90^\circ$  out of phase. There are some microstrip antennas that are found to have circular polarization using a single feed, such as triangular, pentagonal and elliptical [1]. Circular polarization is especially important in the design of antenna arrays.

## 2.5 Radiation Field

Radiation of the microstrip antenna occurs from the fringing fields between the edge of the microstrip antenna radiation patch and the ground plane. At high frequencies the radiation loss of the antenna is much larger than conductor and dielectric losses [2]. When fabricated on thick, low dielectric constant substrates open-circuited microstrip lines radiate more power.

### 2.5.1 Radiation Mechanism of a Microstrip Antenna [1]

Now consider a simple case of a rectangular microstrip antenna spaced a small fraction of a wavelength above ground plane, as shown in Figure 2.9(a). With the assumption that there are no variations of the electric field along the thickness and width of the microstrip patch, the electric field of the radiator is illustrated in Figure 2.9(b). The patch length is about half of a wavelength ( $\lambda/2$ ) and the radiation fields differ along the length.

Radiation of the antenna is mostly resulted from the fringing fields along the open-circuited edges of the patch. This fringing fields can be resolved into two components; normal and tangential components with the respect to the ground plane. The tangential components, which are parallel to the ground plane, are in phase and the resulting fields give the maximum radiated field normal to the surface to the structure. Consequently, the patch can be represented by two slots  $\lambda/2$  apart and radiating in the half space above the ground plane; *see* Figure 2.9(c). The normal components are out of phase because the patch line is  $\lambda/2$  long, thus the far field produced by them cancel in the broadside direction. With the same consideration to the variation field along the width of the patch, microstrip antenna may be represented by four slots surrounding the patch.



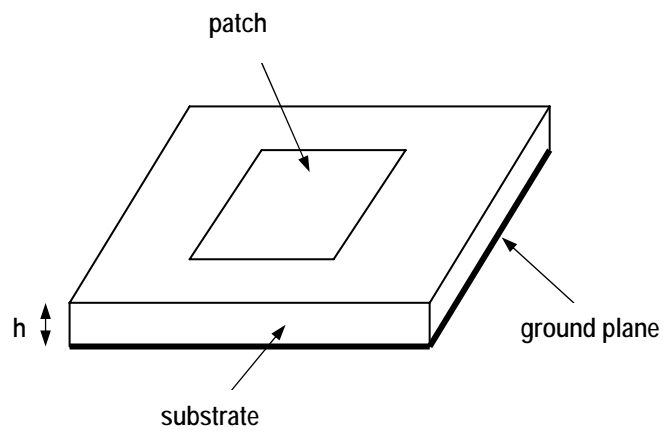

(a)



(b)

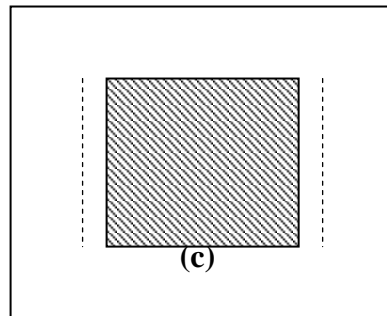

(c)

**Figure 2.9 (a) Rectangular microstrip antenna; (b) Side View; (c) Top View**

## **2.6 Commercial Applications for Microstrip Antennas [5]**

Due to reduction in manufacturing cost and the simplified design process using computer-aided design (CAD), the microstrip antenna has been increasingly in demand in the commercial sector. The current satellite communication applications benefit greatly from the compactness, lightweight and low profile of the microstrip antenna. The commercial applications of microstrip antenna are discussed in the next sections.

### **2.6.1 Mobile Satellite Communications**

Mobile satellite communication can be accomplished by using either a few sets of fixed geostationary station or a larger number of low Earth-orbiting satellites. An example of the geostationary satellite systems is International Maritime Satellite System (INMARSAT), which uses frequencies in the L-band. The INMARSAT version for land application, Standard-M terminal uses a briefcase size microstrip array antenna. The antenna uses six circular patches and provides the gain of 14.5 dB. Toyota Central R&D Labs have produced phased array antennas that can be steered electronically. It consists of 19 dual stacked patches to cover both transmitting and receiving frequency bands.

### **2.6.2 Global Positioning System (GPS)**

GPS is funded by and controlled by the U. S. Department of Defense (DOD). The GPS system was originally designed for and operated by the U. S. military. The

satellite-based GPS has grown to have significant commercial applications, and now there are many thousands of civil users of GPS worldwide.

GPS system made of twenty-four satellites circling the Earth every twelve hours at an altitude of 20,200 km. Each satellites transmits at two frequencies in L-band, at any time four of these satellites will enable users on the ground to determine their positions every 100 nanoseconds. The GPS ground antenna has to be circularly polarized, omnidirectional, wide-beam and low gain antenna. When it comes to size, mass and cost at L-band, the microstrip patch antenna is the best candidate. Ball Corporation has produced a dual stacked patch antenna to achieve the required two L-band frequencies of the GPS system.

### **2.6.3 Direct Broadcast Satellite System (DBS)**

A DBS system has been providing television coverage to public in many countries. The ground user antenna needs high gain of about 30dBi, circularly polarized, low axial ratio antenna and operating at the frequency of 12 GHz. Conventional parabolic reflector antennas can easily meet these specifications. However, they are rather bulky in size and cannot be installed onto an existing building.

Performance of reflector antennas degraded due to rain, wind and snow. These led to development of the microstrip array antennas for DBS. For example, Yagi Antenna Corporation developed an array with 1024 circular patch elements with a peak gain of 33dBi. NHK Science and Technical Research Laboratories have developed several types of mobile DBS receiver for buses, trains, cars and airplanes. In the case of mobile DBS receivers for cars, a microstrip array antenna with a tilted beam has been investigated and tested.

#### **2.6.4 Non-satellite based applications**

Besides for satellite base applications microstrip antenna also used in many other areas. In aircraft, microstrip antenna has been used for the purposes of altimetry, collision avoidance and remote sensing. In medical field, microstrip antenna found to be useful for medical hyperthermia applications.

In remote sensing, the Synthetic Aperture Radar (SAR) system is used to determine ground soil grades, vegetation type, ocean wave speed and direction, agriculture usage and weather prediction. In medical area, microwave energy can be used to heat treat malignant tumors. Microstrip antenna used to apply the microwave radiation because of its lightweight and easy to handle design.

## **CHAPTER III**

### **WIRELESS LOCAL AREA NETWORK (WLAN)**

#### **3.1 Background**

The idea for wireless communications has been around for a surprisingly long time, even before the modern technologies era. Only that, instead of using cellular mobile, wireless LANs and broadband wireless access the generations before us communicates either by sending smoke signals, or light. This idea has been advanced over years until codes being invented including Morse code that could be sent by light, wires, or radio. Whether by light or sound or even smoke signals, the concept is still the same with the modern concept of digital bits, either a unit is on or off, and then timing is an added variable.

The first recorded wireless networking was performed for the first time in 1971 at the University of Hawaii as a research project called ALOHANET [6]. The ALOHANET expanded the mainframe computer networking on the main island of Oahu, to satellite campuses on the other islands without the use of existing unreliable and expensive phone lines. ALOHANET enabled two-way communications between the central computer and each of the stations and communications between the stations had to be done via the centralized computer.

In the late 1980s, the development of wireless LAN standard was started by the *Institutes of Electrical and Electronic Engineers (IEEE)* 802 Working Group. On June 1997 the IEEE 802.11 standard for wireless LAN was approved. From here, wireless technology has emerged from implementations level to become an open solution for providing mobility as well as essential network services where wired networking proved impractical. The market of wireless LAN products is increasing and the standardization, creating huge business opportunities for system implementation companies and consultants.

### **3.2 What is Wireless LAN?**

A wireless LAN is a network without wires. Instead of using twisted wires, coaxial cable or fiber optics, wireless LANs use electromagnetic waves (radio and infrared) as transmission media, sending network traffic over the air. This data and voice traffic is modulated onto carriers and extracted at the receiving end. Multiple carriers can exist in the same space by transmitting at different frequencies. In order to extract data from this network, a receiver tunes in or selects one frequency and filtering out others. This enables users to access shared information without looking for a place to plug in.

Wireless LAN is a flexible data communications system implemented as an extension of or as an alternative for a wired LAN. Thus, wireless LAN adding new flexibility and possibilities to networking. With Wireless LAN, users can access information and network resources as they attend conferences, team up with other users, or move to other campus locations. Now with the growing number of wireless hotspots, users can even access to their company wireless LAN via the net when they are working outstation. Nevertheless, the benefits of wireless LANs extend beyond user mobility and productivity to enable portable LANs because with wireless LANs, the network itself is movable.

### **3.3 Wireless LAN Applications**

After several years of starts and fits wireless LAN finally gained popularity in healthcare, educational and industrial fields. In many applications, wireless LAN systems were purchased for one major reason, to increase user productivity, which will increase the productivity of the whole corporation. The following list describes some of the many applications of wireless LANs.

#### **3.3.1 Healthcare**

In healthcare centers, such as hospitals an accurate record of every patient is important to ensure effective treatment and care for each patient. When dealing with life, a simple mistake proven to be disastrous. Thus, every test result, medical records, pharmaceutical orders and even surgical procedures must be carefully kept. With hundreds of patients to attend, paperwork often overwhelms the staffs and it is time consuming.

With hand-held or notebook computers with wireless LAN capability doctors and nurses in hospitals have access to patients' records from anywhere around the hospital. Patient information can be delivered instantly and any update of patient data could be done immediately. This will increase the productivity of the healthcare.

After attending a patient, a doctor can just key in further treatment needed for that patient in his hand-held notebook. Then the nurse on duty will receive the instructions and do as the doctor asked. A nurse then will enter any progress into the patient's record. And a doctor can check the progress through any hand-held computer from anywhere in the hospital.

### **3.3.2 Education**

In universities or at training sites with wireless LAN system students use wireless connectivity to facilitate access to information, information exchanges, and learning. Wireless LANs, are helping provide high-tech education by providing campus-wide connectivity for students, teachers and administrators. Wireless LANs in education offer a low-cost solution to high-speed Internet access.

From his room a student can set up a discussion link via wireless LAN with his friends who are staying on the other side of the campus. This is time saving since they can update each other on the recent findings related to their project at no time.

By installing wireless LAN students can share a single high-speed Internet connection from any Internet hotspot in the university. The use of a wireless LAN to share a high-speed Internet connection allows the user to stay mobile and save money, because there are no wires to buy or install.

A lecturer sitting in his room can guide a student who is doing some testing in the laboratory via wireless phone. This will keep them constantly be in contact with each other and it is free since there is no monthly fee. Wireless phone, which work just like cell phones when they are in the coverage of the wireless LAN. The student then will enter the testing result into a held-hand computer. The lecturer will receive the result and analyse it, then will tell the student if the result is satisfactory or any further improvement needs to be done.

### **3.3.3 Inventory**

Any retail organization need to order, price, sell and keep inventories of their products. This can be made easier by using wireless LAN. Wireless LAN system can



track and update inventory in real-time thus, enabling efficiency and accuracy to increase significantly.

In the manufacturing environment, wireless LAN can keep the raw materials and finished product information up-to-date. As soon as a clerk purchases or stocks a product, a wireless management solution can update the inventory. Salespeople equipped with wireless enabled bar code scanners can check or change product prices and/or check the number in stock. They are then able to complete the process such as pricing and placing special orders from anywhere within the store.

The improved accuracy provided by using a wireless LAN to manage inventory creates a chain reaction of benefits. A clerk equipped with handheld scanner enters the information right into the main computer via wireless link. As a result, there is no paperwork to deal with and human error when entering data can be reduced. This will lead to very accurate financial records. Accurate financial records is important to manufacturing companies because it ensure that correct taxes are paid and fines (and possible law suits) are kept to a minimum.

### **3.4 Wireless LAN Configurations**

Wireless LANs are built using two basic configurations, independent (or peer-to-peer) WLANs and infrastructure WLANs. Independent WLAN is the simplest wireless LAN configuration that enables a set of PCs equipped with wireless adapters and within a range of one another to set up network, as shown in Figure 3.1. This network created by the wireless adapters themselves and requires no administration or central controller. It is useful in places where a few computers might congregate and need not to access another network. For example, at home or in a conference room where a group of people gather to exchange ideas.

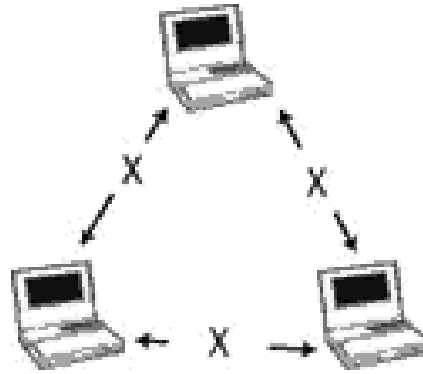

**Figure 3.1 Independent WLAN**

In infrastructure networking, multiple access points link an existing wired network to wireless LAN. The access points act as a central controller to coordinate transmission and reception from multiple wireless devices within a particular range. In infrastructure WLAN multiple access points provide coverage over a larger area or an entire campus, such as multi-floor building, hospitals and factories. In this environment, a handheld PC or data collector with a *Network Interface Card (NIC)* can roam within the coverage area without losing a live connection to the corporate network.

With multiple access points, wireless LAN can be configured differently to satisfy connectivity requirements. In Figure 3.2, each cell can be set up with different parameters to keep each cell separate. This would be of benefit for corporations with various functional groups. For example, cell A covers the manufacturing department and cell B for the management department. Identical configuration for all the cells also could be done to maintain seamless connections throughout the facilities. However, for a small area such as a home, only a single access point is needed to do the job.

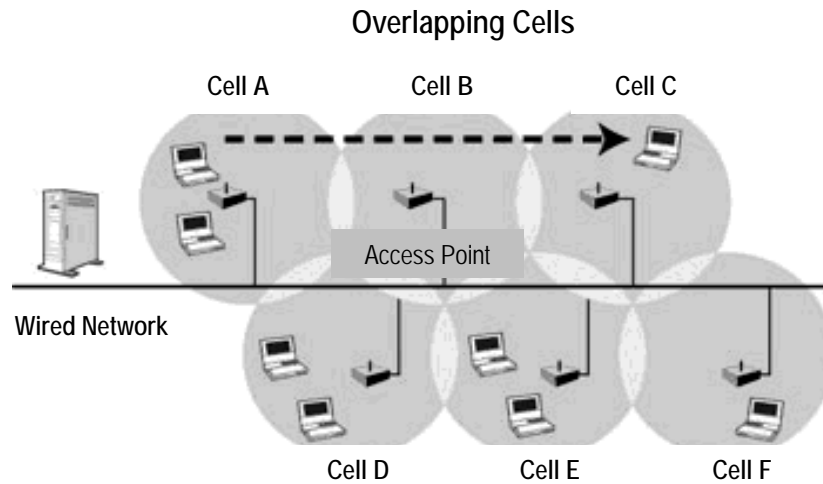

**Figure 3.2 Infrastructure WLAN Provides Continuous Network Connectivity**

### 3.5 Wireless LAN Technology Options

There is a range of different technologies that can be used in wireless LAN applications. Each technology comes with its own advantages and limitations depend on the applications. Below are the discussions on two technologies options for wireless networking within a local environment, radio-based wireless LAN and infrared.

#### 3.5.1 Radio-Based Wireless LAN

Radio wave is widely used as propagation medium in wireless networking. The advantage of radio waves over other options of wireless connectivity is that they can interconnect users without line of sight, which means they propagate through walls and other obstructions with little attenuation. Radio-LAN products allow a user with a portable computer to move freely through the facility while accessing data

from a server or running an application. However, radio waves that penetrate walls cause security problem. Unauthorized person from outside the facility could receive sensitive information. However, a few security measurements could be done to protect the information from being understood by inappropriate person.

### 3.5.1.1 Medium Access Control [6]

Medium access control is a Data Link Layer function in a radio-based wireless LAN that allows multiple appliances to share a common transmission medium via a carrier sense protocol. The protocol allows a group of portable computers to share the same frequency and space at the same time. Carrier sense protocol, commonly known as *Carrier Sense Multiple Access with Collision Detection* (CSMA/CD) is used to organize the networking that only one transmission can be done at a time. Figure 3.3 illustrates the common CSMA/CD used.

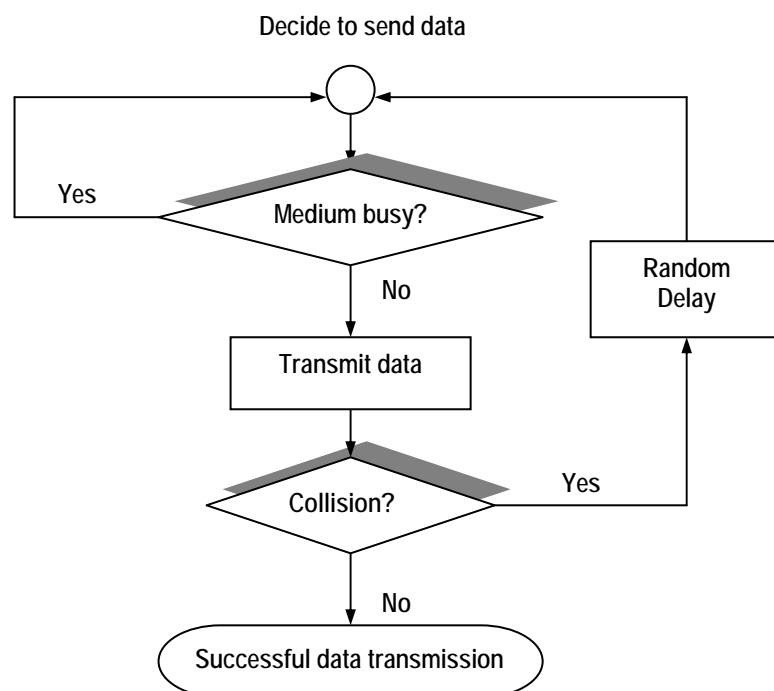

### **Figure 3.3 The Operation of The Carrier Sense Protocol**

#### **3.5.1.2 Spread Spectrum Modulation**

Spread spectrum is a modulation technology, which spreads a transmission signal over a broad band of radio frequencies. It is ideal for wireless data communications because it is less susceptible to the problematic interference and creates little interference. Spread spectrum transmitters send signals out over a multiple range of frequencies at exceptionally low power in contrast to the narrow band radio that concentrate all their power into a single frequency. Therefore, greater bandwidth is consumed for transmission than that needed for transmission.

In military, spread spectrum is used because it is harder to detect or decode compare to narrowband transmissions. Unless the receiver is tuned to the right frequency, a spread spectrum signal is like a surrounding noise. For commercial applications, the same properties mean spread spectrums are less sensitive to interference and less likely to interfere with other users. There are two types of spread spectrum techniques, frequency hopping and direct sequence.

##### **a) Frequency-Hopping Spread Spectrum**

Frequency Hopping Spread Spectrum (FHSS) uses a carrier that hops from frequency to frequency as a function of time over a wideband of frequencies. For example, a frequency hopping radio will hop the carrier frequency over the 2.4 GHz frequency band between 2.4 GHz and 2.483 GHz; *see* Figure 3.4.

The frequencies change in a sequence and to properly receive the signal receiver must be set to the same hopping code at the right time and right frequency. The sequence is like a code to the system that prevents an unintended receiver from receiving the frequency hop. If the hopping rate is higher than the bit rate, the system

is fast FHSS. If it is the other way round, then the system is slow FHSS. Slow FHSS is widely used in commercial systems due to the complexity of fast FHSS.

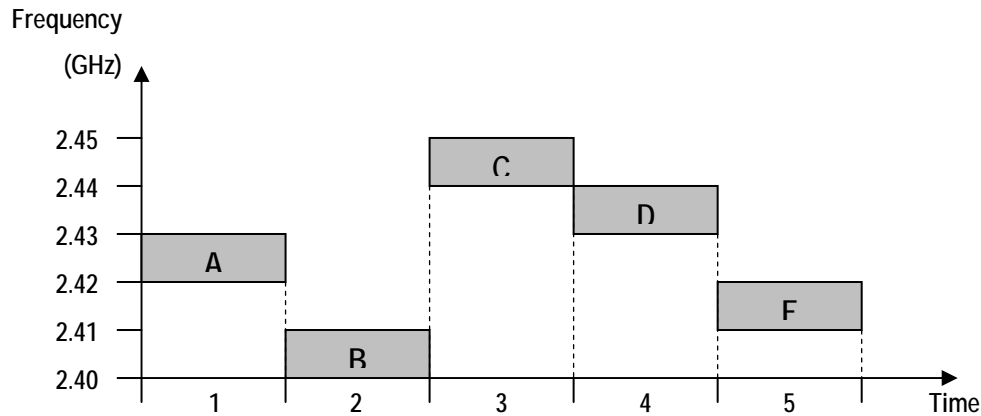
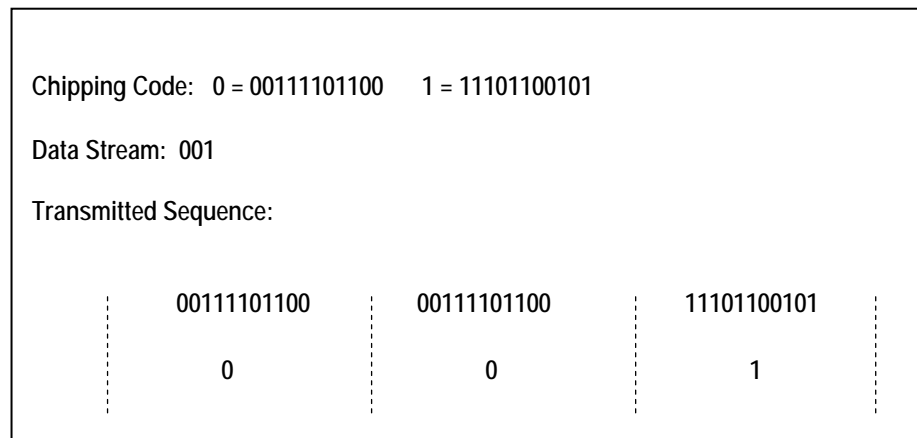

**Figure 3.4 Frequency Hopping Spread Spectrum**

### b) Direct-Sequence Spread Spectrum Technology

In Direct Sequence Spread Spectrum (DSSS) systems, the bit sequence is combined with a higher-rate binary sequence to obtain a new sequence with the chip rate. DSSS produces a redundant bit pattern for each bit to be transmitted. This bit pattern is called a chip (or chipping code). The longer the chip, the greater the probability that the original data can be recovered and of course the more bandwidth required. The IEEE 802.11 Working Group has set its minimum processing gain requirement at 11.

Figure 3.5 shows an example of DSSS operation. Chipping code is set to represent logic 1 and 0 bits. As data is transmitted, the corresponding code is sent. As an example, transmission of a data bit equal to 1 would result the series of 00111101100 transmitted. Error recovery mechanisms embedded in the adapter can recover corrupted data without the need for retransmission. To an unintended receiver, DSSS appears as low-power wideband noise.



**Figure 3.5 Direct-Sequence Spread Spectrum**

### 3.5.2 Infrared

Infrared is a light waves having wavelengths ranging from about 0.75 to 1,000 microns, which is much shorter than radio waves but higher in frequency. Infrared light plays an important part in short-range wireless communications. Because Infrared rays cannot penetrate through solid objects, IR technology is suitable for an indoor wireless LAN. Infrared applications are limited by line-of-sight transmission and this is an advantage when the data should be confined to a room and not to be disclosed. Therefore, IR is more secure to eavesdropping compare to the radio transmissions. With diffused IR wireless LAN do not require line-of-sight but still the cells limited to individual rooms.

Infrared is free from common noise sources of the radio waves such as microwave ovens and radio transmissions. However, because of its limited coverage infrared is not as suitable as radio waves for mobile applications.

Most infrared LAN consists mainly of two components, adapter card and transducer. The adapter card plugs into the PC or printer via *Personal Computer Memory Card* (PCMC) slot. The adapter card handles the protocol needed to operate in a shared-medium environment. The transducer is similar to antenna in a radio-based LAN that is to transmit and receives infrared light signals.

### **3.6 IEEE 802.11 Standard [6,7]**

IEEE 802 is the standard for Local and Metropolitan Area Network under *Institutes of Electrical and Electronic Engineers*. IEEE 802 comprises a series of seven standards known as IEEE 802.x and one particular standard is the 802.11, standard for wireless LAN.

The development of IEEE 802.11 standard started in the late 1980s by the IEEE 802.11 Working Group. In 1997, the IEEE finalized the 802.11 wireless LAN standards, specifying parameters on both of the physical (PHY) and medium access control (MAC) layers of network. The PHY layer handles the transmission of data, can use either DSSS, FHSS or base band infrared (IR) pulse position modulation. 802.11 standard operates data rates of 1 and 2 Mbps using spread spectrum modulation in the 2.4 – 2.483 GHz radio band which is the unlicensed band for *Industrial, Scientific and Medical* (ISM) applications and 300- 428,000GHz for IR transmission. The 802.11 standards define two separate forms of 802.11 spread spectrum they are the frequency hopping spread spectrum and direct sequence spread spectrum.

In late 1999, the IEEE ratified two supplements to the initial 802.11 standard: 802.11a and 802.11b. The 802.11b standard or widely known as WiFi is the first to take off and operates in the unlicensed 2.4GHz band. The 802.11a standard also operates at unlicensed band but at higher frequency of 5GHz. Last June, IEEE Standards Association's Board produced IEEE 8.2.11g, an amendment to WiFi.



### **3.6.1 IEEE 802.11b**

WiFi is an acronym for Wireless Fidelity is a well-known name for wireless local area network based on IEEE 802.11b standard. Although ratified at the same time as 802.11a, 11b came to market first due to its simplicity from a development perspective. It's based on the 2.4GHz frequency using Direct Sequence Spread Spectrum (DSSS) modulation, giving an effective data rate of 11Mbps. 802.11b systems provide ranges of approximately 100 meters.

WiFi network are able to perform at least basic management of mutual inference among users through a combination of Multi Access Carrier-layer techniques and frequency channelization. However, WiFi networks will remain vulnerable to other sources of radio frequency interference, such as a microwave oven operating in the same frequency or a nearby WiFi network under the management of different company. With the density of WiFi installed are still relatively low today, this is not a serious problem. However, it will become severe in the future as the density increased.

### **3.6.2 IEEE 802.11a**

IEEE 802.11a is a physical layer standard that operates at less crowded 5GHz spectrum specifies eight available radio channels. It transfers data up to five times faster than IEEE 802.11b, improving quality of steaming media with increased bandwidth of 54MHz. The 802.11a standard also uses the latest generation of frequency hopping technologies called Orthogonal Frequency Division Multiplexing (OFDM). This technology allows for significantly better usage of available channels

by creating parallel channels that make the transmission effectively full duplex. Although, solving interference problem and better security at 5GHz but the range is more limited, for the same coverage area 802.11a requires more access points than 802.11b to maintain maximum coverage.

IEEE 802.11a offers high data rates and more channels, therefore more opportunities to escape interference from other users. Nevertheless, 802.11b technology is incompatible with 11a and its products are much more expensive to manufacturer. Now, with the recent ratification of 802.11g standard that is compatible with 802.11b, which is widely used all around the world, 11a is standing at a crossroad. Moreover, wireless consumers are primarily price-driven and they normally will settle for cheaper product.

### **3.6.3 IEEE 802.11g**

IEEE 802.11g is the latest wireless LAN standard ratified by the IEEE Standards Association's Standard Board on 12 June 2003. The new standard offers about the same data rate as 802.11a, nominally 54Mbps and this is three to five time faster than 802.11b version. IEEE 802.11g using the same data Orthogonal Frequency Division Multiplexing (OFDM) modulation as the 11a standard. It operates at the 2.4GHz band and is inherently compatible with the popular 11b standard. Similar to 802.11b, 11g specify three available radio channels at 2.4-2.483GHz band.

At lower frequency, 802.11g devices are cheaper to manufacture. Compare to 802.11a, the 802.11g standard also comes with three advantages: lower power consumption, better penetration and longer range. However, it is cost not power usage, range or data rate probably will be the determine factor to win the consumers [8].

### 3.7 Wireless LAN Security

Security is one of the main concerns of wireless LAN; it is vulnerable to eavesdroppers and hackers, even the unskillful one. Currently wireless LANs utilize Wired Equivalent Privacy (WEP) which many agree that it is not particularly robust. It is because even when the WEP is operating, the encryption key can be recovered by a hacker with only a modest amount of effort.

There is another security system adopted by WiFi, the Virtual Private Network (VPN). VPN system creates an encrypted tunnel over the wireless LAN to protect the network traffic from eavesdroppers. This system is proven a strong, however it lowers the wireless LAN performance. VPN users are required to manually re-authenticate and set up a new VPN tunnel every time they roam between access points. Any interruption in networking will disengage the VPN connection and force users to reconnect to the VPN server; this can be troublesome.

After the limitation of WEP, IEEE came up with 802.1x and Extensible Authentication Protocol (EAP) solution. The 802.1x, a standard for Port Based Access Control for both wired and wireless networking itself cannot guarantee the security of wireless networking. Combination of 802.1x and EAP resolve the WEP's problem: static user and session keys. With this solution, WEP keys can be unique for individual users and individual sessions. Keys can be set to expire automatically every ten minutes to force constant re-keying and EAP authentication will run again to buy another ten minutes. This makes it impossible for hackers to collect 10-1000 MB of data to break WEP.

### 3.8 Bluetooth

Bluetooth is a short-range wireless technology that allows any sort of electronic equipments from computers, laptops, mobile phones and PDAs to make its own connections without wire or any direct action from the user. Data transfer speeds for Bluetooth range from 1 to 2 megabits per second (Mbps) within the range of 10 to 100 meters. The Bluetooth standard was developed to get around the problems that come with both infrared and cable synchronizing systems.

The Bluetooth system communicates in the same unlicensed 2.4GHz band as the WiFi. This band is also open to any radio system such as baby monitors, cordless phone and gate door openers. This is why it is a crucial part of design process to make sure that Bluetooth and these other device do not interfere with one another. To limit the inference to the minimum, Bluetooth uses a fast acknowledgement and frequency-hopping scheme to make link robust. Typically, Bluetooth hops faster and uses shorter packets and this minimize the impact of interference from other radio systems that use the same frequency band.

Bluetooth devices can create point-to-point and point-to-multipoint connections. A connection with two or more devices (maximum eight) is known as piconet. One device of the devices will automatically become the master of the piconet to avoid interference among the devices. In each slot, a packet can be exchanged between the master and one of the slaves. Each packet begins with a 72-bit access code that is derived from the master identity and is unique for the channel. Every packet exchanged on the channel is preceded by this access code. Recipients on the piconet compare the incoming signals with access codes, if the two do not match, the received packet is considered not valid on the channel. If two or more piconets communicate with each other, they are called a *scatternet*.

## **CHAPTER IV**

### **ANTENNAS FOR WIRELESS LAN**

Antenna is a low cost solution that enables a variety of high-speed data applications virtually at any scenarios where wireless network are deploy. An antenna can also be viewed as a transitional structure between free-space and a transmission line, which is designed to radiate or to receive electromagnetic waves. An important property of an antenna is the ability to focus and shape the radiated power in space, for example it enhances the power in some wanted directions and suppresses the power in other directions.

Antenna plays an important part in a transmitting or receiving system. An antenna couples radio frequency energy to the air medium. A transmitter within an access point sends radio frequency signals to the antenna, which acts as a radiator and propagated the signal through the air. Then, the signals are captured from the air and send to the receiver.

Microstrip patch and Yagi antenna are the common directional antennas used as transmitter in wireless LANs for indoor applications. These antennas are the main choice because of their rugged and unobstructed appearances. Ease of installation without major modifications is an advantage for these types of antennas. As a receiving antenna, omni-directional antenna is a prime choice.

## **4.1 Characteristics for Wireless LAN antennas**

In any wireless LAN deployment, radio frequency coverage is a prime concern and here is where antenna plays a vital role. If the antenna is ignored, then the access point may not achieve the maximum effective range and this can be a costly mistake. An effective antenna solution should boost the range and corresponding coverage of a wireless LAN, which decreases costs because of fewer access points.

There are four common characteristics for wireless LAN antennas; frequency, power, radiation pattern and gain. Brief discussions on these characteristics are as stated below.

### **4.1.1 Frequency**

All antenna are designed to radiate and receive at certain frequency band, Antenna only will work efficiently if the frequency of the antenna and radio matches. For wireless LAN there are two currently used frequencies, tuned to 2.4GHz for 802.11b and g standards and 5GHz for 802.11a standard. Bluetooth also used the 2.4GHz band.

### **4.1.2 Power**

Antenna must be able to handle a specific amount of power put out by the transmitter. For 802.11 applications, the antenna generally rated greater than 1 watt

in order to handle the peak transmitted power of the access point. In many applications, power specification is not a major concern because of the relatively low power that wireless LANs transmit.

### 4.1.3 Radiation Pattern

Radiation pattern defines the radio wave propagation of the antenna. Basic radiation pattern is isotropic which means the antenna transmits radio waves in all direction equally. The antenna used for wireless LANs applications have omni-directional and directional radiation patterns.

Omni-directional antennas propagate radio frequency signals in all directions equally on a horizontal plane but have limited range on the vertical plane; *see* Figure 4.1. This radiation pattern resembles that of a very large doughnut with the antenna at the center of the hole. Omni-directional antennas provides the widest coverage, making it possible to form circular overlapping cells from multiple access points located throughout the building. Most access points that used standard omni-directional antennas having relatively low gain, around 2 to 4dB. Hence, greater number of access points needed to cover specific area compares to higher gain antenna.

A directional antenna transmits and receives energy more in one direction than others. Illustrated in Figure 4.2 is the radiation pattern for directional antenna, it is similar to the light that a flashlight or spotlight produces. Directional antennas have higher gains compare to that omni-directional antennas, such as 6dB and higher. The higher gain antennas provide greater range but have a narrower beam width, which limits coverage on the sides of the antennas. High gain antennas work best for covering large, narrow areas, or supporting point-to-point links between buildings. In some cases, a directional antenna will reduce the number of access

points needed within a facility. This can reduce the number of access points and lower costs.

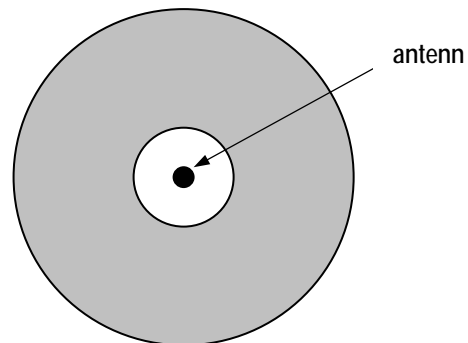

**Figure 4.1 Omni-directional Antenna Radiation**

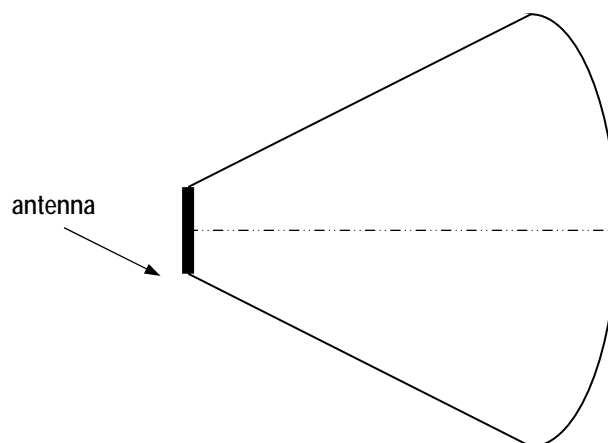

**Figure 4.2 Directional Antenna Radiation**

#### **4.1.4 Gain**

The gain of antenna represents how well it concentrates the effective signal power in a particular direction. The unit for antenna gain is measured in decibels (dB). The number of dB is 10 times the logarithm of output power divided by the



omni-directional radiated power or isotropic power. For instance, a transmitter outputting 100 milliwatts to an antenna having 3dB gain produces 200 milliwatts effective power.

Most antenna manufacturers specify gain as dBi, which is the gain relative to an isotropic source. It is how much the antenna increases the transmitter's power compared to a fictitious, isotropic antenna. The dBi unit represents the true gain that the antenna provides to the transmitter output.

## **CHAPTER V**

### **RECTANGULAR MICROSTRIP ANTENNAS**

#### **5.1 Introduction**

Rectangular microstrip antenna is the simplest configuration of the microstrip patch. Due to the simplicity of the structure, extensive researches have been done and numerous methods have been made to analyse the characteristics of rectangular microstrip antennas. These have varied from mathematical formulations to simple models. Included in this chapter are some of the models developed and design procedure for rectangular microstrip antenna. Finally, design considerations for practical antennas are discussed.

#### **5.2 Resonant Frequency**

The resonant frequency for the rectangular microstrip antenna can be obtained by using the cavity model. Cavity model is based on some assumptions regarding the dimensions of the microstrip antenna. Due to the distance between the

patch and ground plane is much smaller compare to the wavelength, only the  $z$  component of the electric field and the  $x$  and  $y$  components of the magnetic field exist. Because of the small height the fields are independent of the  $z$  coordinates. The electric current has no components normal to the edge patch at any point.

With all the assumptions, microstrip antenna may be treated as a resonant cavity with the top and the bottom planes forming electric walls and a magnetic wall along the edge [1]. The model is illustrated in Figure 5.1 below. Then by solving the cavity problem gives the  $TM_{nm}$  modes of the fields within the cavity.

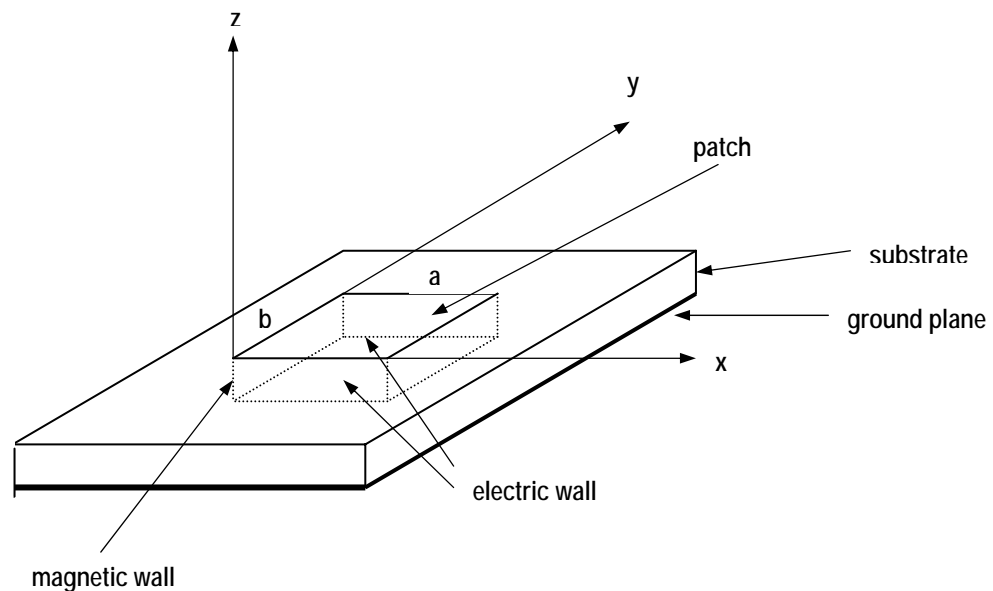

**Figure 5.1 Cavity model of the rectangular microstrip antenna**

By using the cavity model, the resonant frequency of the rectangular microstrip patch is stated in Equation 5.1 below, where  $m$  and  $n$  are the standing waves integers which are the number of half period variations in the electric field across the patch's dimensions,  $c$  is the free space velocity and  $\epsilon_r$  is the relative dielectric constant.

$$f_{mn} = \frac{c}{2\pi\sqrt{\epsilon_r}} \sqrt{\left(\frac{m\pi}{a}\right)^2 + \left(\frac{n\pi}{b}\right)^2} \quad (5.1)$$

In the analysis, the microstrip antenna was modelled as a resonator with electrically conducting top and bottom and magnetically conducting sidewalls. But in real antenna, the near field of the microstrip antenna escapes into the surrounding and affect the resonant frequency. This spreading of the field is known as the fringing field effect. To balance the effect of the fringing fields, the following effective values for the length and width may be used [5].

$$a_e = a + \frac{h}{2} \quad (5.2)$$

$$b_e = b + \frac{h}{2} \quad (5.3)$$

To get better accuracy, formula for the resonant frequency and the effective values are given in Equation 5.4, 5.5 and 5.6. With  $f_{r0}$  is the resonant frequency stated in Equation 5.1.

$$f_{r1} = f_{r0} \frac{\epsilon_r}{\sqrt{\epsilon_e(a)\epsilon_e(b)}} \frac{1}{(1 + \Delta)} \quad (5.4)$$

where

$$\Delta = \frac{h}{a} \left[ 0.882 + \frac{0.164(\epsilon_r - 1)}{\epsilon_r^2} + \frac{(\epsilon_r + 1)}{\pi\epsilon_r} \times \left\{ 0.758 + \ln\left(\frac{a}{h} + 1.88\right) \right\} \right] \quad (5.5)$$

$$\epsilon_e(x) = \frac{\epsilon_r + 1}{2} + \frac{\epsilon_r - 1}{2} \left[ 1 + \frac{10h}{x} \right]^{-1/2} \quad (5.6)$$

$x$  is substitutes for by  $a$  or  $b$ , to give the values for  $\epsilon_e(a)$  or  $\epsilon_e(b)$ .

### 5.3 Design Procedure for Rectangular Microstrip Antenna [1]

The first design step is to determine the width of the patch. That is given by an expression in Equation 5.7.

$$W = \frac{c}{2f_r} \left( \frac{\epsilon_r + 1}{2} \right)^{-1/2} \quad (5.7)$$

Once  $W$  is determined, the effective dielectric constant  $\epsilon_{eff}$  and the line extension  $\Delta l$  can be calculated using Equation 5.9 and Equation 5.10 respectively, where  $h$  is the substrate height. Then Equation 5.8 gives the value of the length of the patch,  $L$ .

$$L = \frac{c}{2f_r \sqrt{\epsilon_{eff}}} - 2\Delta l \quad (5.8)$$

$$\epsilon_{eff} = \frac{\epsilon_r + 1}{2} + \frac{\epsilon_r - 1}{2} \left( 1 + \frac{10h}{W} \right)^{-0.555} \quad (5.9)$$

$$\Delta l = 0.412h \left\{ \frac{0.262 + \frac{W}{h}}{0.813 + \frac{W}{h}} \right\} \left( \frac{\epsilon_{eff} + 0.3}{\epsilon_{eff} - 0.258} \right) \quad (5.10)$$

Because the patch is surrounded by two dielectric media, which are the substrate where the patch is mounted and the air above it, the effective value for the dielectric constant,  $\epsilon_{eff}$  is used. The fringing fields cause the effective length to increase that is why the amount of  $\Delta l$  must be minus from each side of the patch to get effective length required.

## CHAPTER VI

### TRIANGULAR AND PENTAGONAL MICROSTRIP ANTENNAS

#### 6.1 Triangular Microstrip Antenna

In Figure 6.1 is the triangular microstrip antenna, where  $a$  is the sidelength and  $h$  is the substrate height.

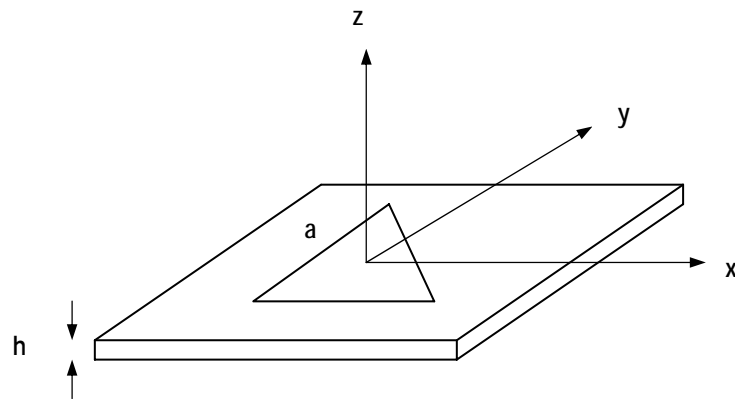

**Figure 6.1 The Triangular Microstrip Antenna**

Similar to the rectangular microstrip antenna discussed in previous chapter, the triangular microstrip antenna also can be model using cavity model. And the resonant frequency expression for triangular microstrip antenna is given by:

$$f_{m,n,1} = \frac{2c}{3a\sqrt{\epsilon_r}} (m^2 + mn + n^2)^{1/2} \quad (6.1)$$

where  $m, n, l$  are the standing wave integers due to the electric and magnetic boundary conditions,  $c$  is the free space velocity and  $\epsilon_r$  is the relative dielectric constant and  $a$  is the sidelength of the equilateral triangle.

### 6.1.1 Correction Factors

The relationship given in Equation 6.1 however, does not take into consideration the effects of fringing field. There are several techniques available for correcting the fringing fields effect. Each technique was based on variety of observations and all agree on the basic equation given in Equation 6.1. In these techniques the effective values for the side length and the dielectric constant have been proposed. Brief discussion on each technique of correction is given in the following sections.

#### 6.1.1.1 Garg and Long [5]

The idea behind this method is that the fringing fields on equilateral triangular microstrip patch is equal to the effect of the fringing fields on a disk possessing the same metalised area. This concept is shown in Figure 6.2.

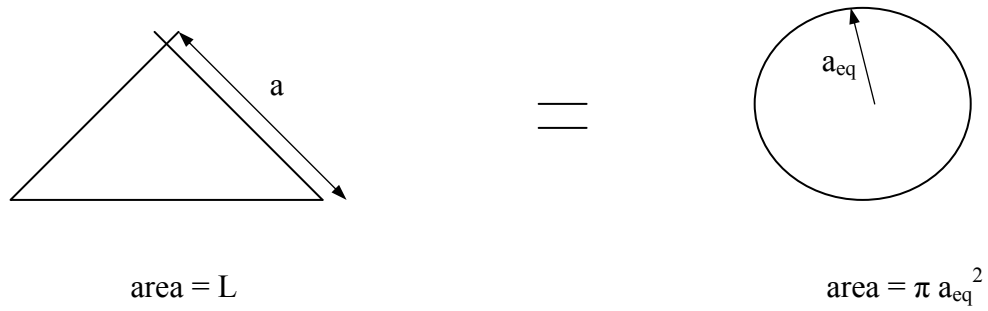

**Figure 6.2 Equivalent areas**

The formula for the effective radius of a disk antenna is given in Equation 6.2.

$$a_e = a \sqrt{1 + \frac{2h}{\pi \epsilon_r a} \left( \ln \frac{\pi a}{2h} \right)} = 1.7726 \quad (6.2)$$

Before this formula can be used for the equilateral triangular patch, an equivalent radius  $a_{eq}$  must be substituted for disk radius ( $a$ ). By substituting,  $a$  with  $a_{eq}$ , Equation 6.2 becomes:

$$a_e = a_{eq} \sqrt{1 + \frac{2h}{\pi \epsilon_r a_{eq}} \left( \ln \frac{\pi a_{eq}}{2h} \right)} = 1.7726 \quad (6.3)$$

### 6.1.1.2 Dahele and Lee [9]

The resonant frequency for the circular patch uses an effective radius only, to correct for the fringing field effect, while the annular ring uses both an effective radius and effective dielectric constant. Dahele and Lee used both of these methods



to calculate the resonant frequency for microstrip patch under several different modes. The results from these methods then compared with practical observations of the antenna's resonant frequency to determine the best method use for microstrip patch. It was found out that the method for circular gave the best result. Hence, the effective radius developed for the circular patch given in Equation 6.3 was proposed as the most accurate method of correcting for the fringing fields in triangular patches.

$$a_{eff} = a + \frac{h}{\sqrt{\epsilon_r}} \quad (6.4)$$

### 6.1.1.3 Gang [5]

Gang proposed to keep the formula for the effective radius as given in the above paper by Dahele and Lee and also to replace the relative dielectric constant for an effective one. The new expression for this dielectric constant is based on finding an average value for the effective permittivity. Since the permittivity does not vary linearly with the width being considered, this was done using integration. And value of the dielectric constant  $\epsilon_{eti}$  given by:

$$\epsilon_{eti} = \frac{1}{2}(\epsilon_r + 1) + \frac{1}{2}(\epsilon_r - 1)(\alpha_{ii}) \quad (6.5)$$

where

$$\alpha_{ii} = \frac{\sqrt{(A+H)H} - A \ln(\sqrt{H} + \sqrt{H+A})}{H} + A \frac{\ln(A)}{2H} \quad (6.6)$$

$$A = 6\sqrt{3}h \quad (6.7)$$

$$H = \sqrt{3} \frac{a}{2} \quad (6.8)$$

#### 6.1.1.4 Guney [5]

Guney produced another formula for the effective sidelength to be used in the resonant frequency expression given in Equation 6.1. The formula proposed is as given below.

$$a_{e2} = a + \frac{h^{0.6} a^{0.38}}{\sqrt{\epsilon_r}} \quad (6.4)$$

## 6.2 Pentagonal Microstrip Antenna

Circular polarization is theoretically possible from a microstrip antenna excited by a single feed if two spatially orthogonal modes are excited in phase quadrature [1]. This can be achieved in a pentagonal patch as shown in Figure 6.3 below. A pentagonal patch with typical dimensions for circular polarization is shown in Figure 6.4, where  $\lambda$  is the wavelength [3].

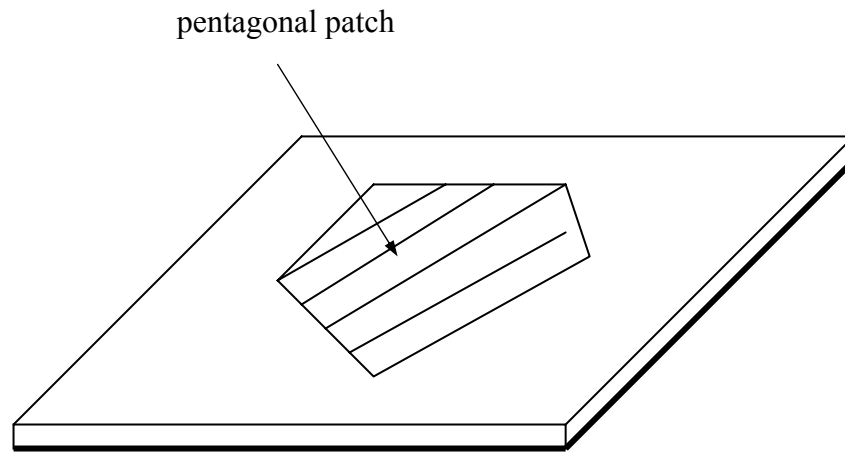

**Figure 6.3 Geometry of a Pentagonal Patch**

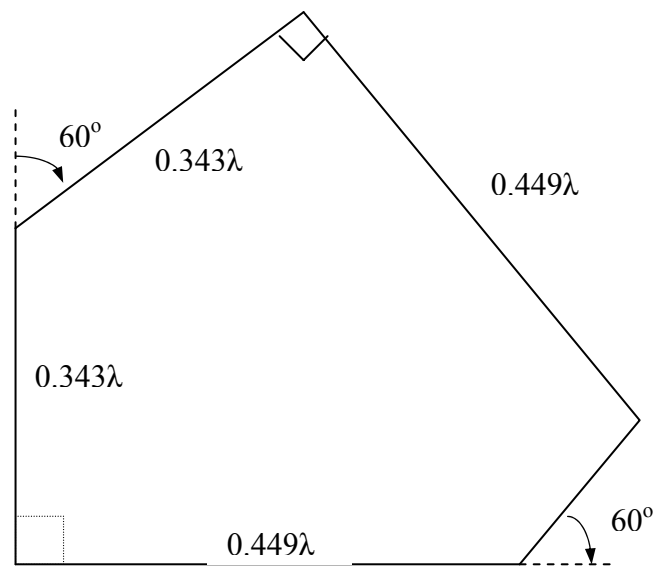

**Figure 6.4 Pentagonal Patch for Producing Circularly Polarized Field**

## CHAPTER VII

### DESIGN PROCESS AND FABRICATION

#### 7.1 Design Methodology

The design requirement is to produce microstrip antenna that resonate at the frequency of 2.4GHz. The antenna must resonate within the frequency of 2.4 GHz to 2.483 GHz, which is compatible with wireless LAN standard IEEE 802.11b and g or commonly known as WiFi. The antenna is proposed to use as a transmitting antenna in the wireless LANs environment. Nonetheless, the antenna can be used as a receiving antenna because of the antenna's reciprocity; the transmitting and receiving properties of the antenna are identical.

The design process started with the selection of the suitable shape for patch. After selection was made, calculations for the antenna dimensions were carried out to determine the size of the antenna. Then, the antenna performance, that is the return loss measurement was analyzed using Microwave Office 2001, if the results is not as desired modifications were made to the patch. The port location that gave the best performance to antenna was also determined using Microwave Office 2001.

Antennas that fulfill the desired characteristics were produced and the real return loss measurements were carried out. If the antenna matches the requirements

then the design process stops here and the antenna polar pattern will be examined. If the antenna did not fulfill the requirements then the design process will start again from the computer analysis to improve the design. The design process flow chart is as illustrated in Figure 7.1 below.

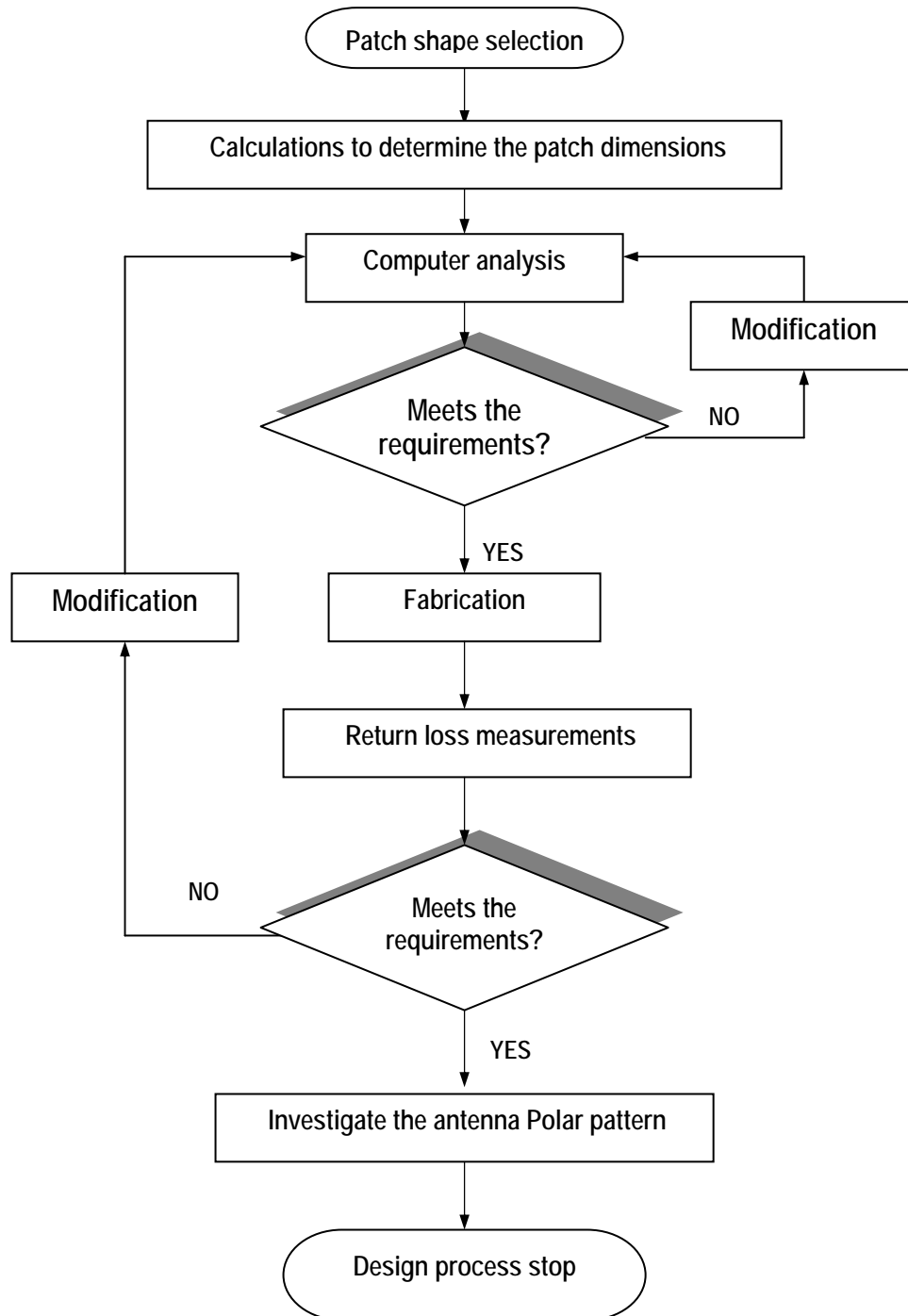

**Figure 7.1 Design Process Flow Chart**

## 7.2 The Design

Two different shapes of microstrip antenna were design, rectangular and pentagonal. The rectangular shape was selected due to the simplicity of the rectangular patch design. The selection for the pentagonal shape was made due to its rugged look and its circular polarization. The excitation method used is the coaxial probe, the selection also due to the simplicity of the design. By using this method the antenna and the feed line can be designed separately. In calculations woven fiberglass substrate with  $\epsilon_r = 4.88$  and  $h=1.57\text{mm}$  were used.

### 7.2.1 The Rectangular Patch

Dimensions for a single-patch antenna was calculated using the formulas given in Equation 5.7 and Equation 5.8. By substituting the related values to the equations gives the dimensions of width,  $W= 36.45\text{mm}$  and length,  $L= 28.25\text{mm}$ . A diagram of the rectangular patch is shown in Figure 7.2.

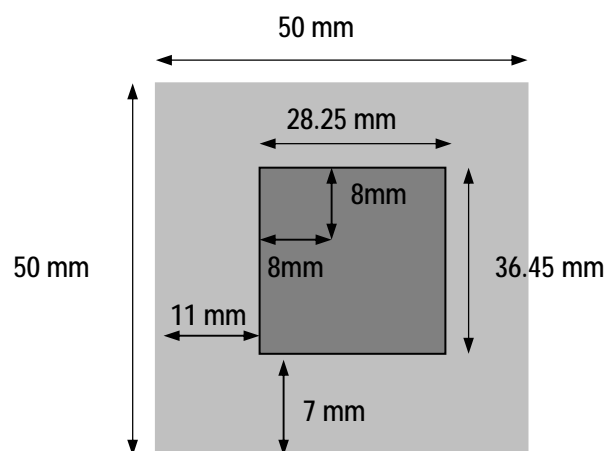
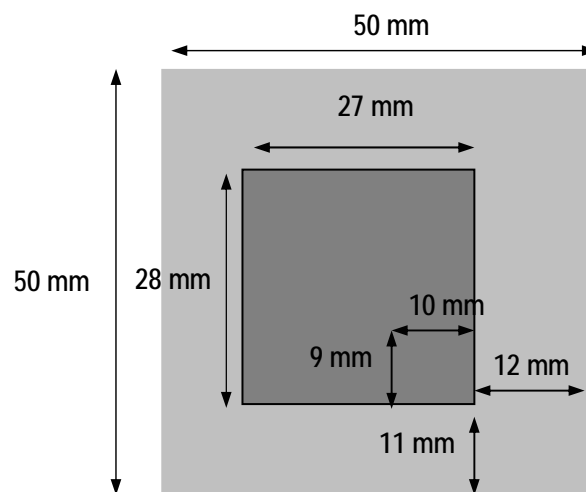

**Figure 7.2 The Rectangular Patch**

Return loss measurements for the calculated rectangular microstrip antenna using computer simulation is as shown in Figure 7.3. The optimum bandwidth is 2.5% starting from 2.36 GHz to 2.42 GHz. This result did not fulfill the desired bandwidth and modification was made to the patch.

### 7.2.2 Modification of the Rectangular Antenna

The original design was modified, where the dimensions as well as the port location were changed to fit the requirements. All these modifications were done using the Microwave Office 2001. As a result two new rectangular patches were designed. Both dimensions of the patches were reduced to give operation at higher frequency and wider bandwidth. Figure 7.4 shows the dimensions of the modified patches.



(a) Rectangular a

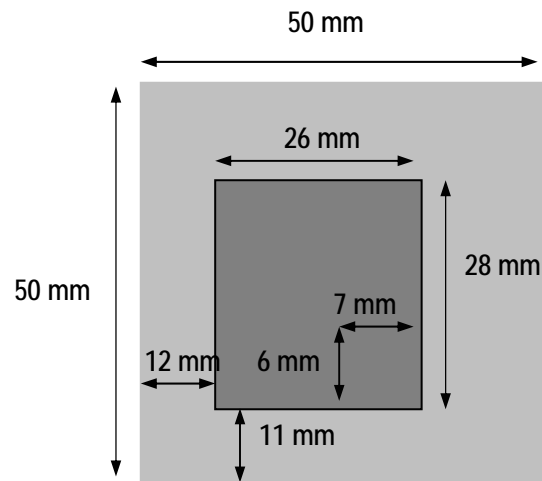

(b) Rectangular b

**Figure 7.4 Configurations of the Modified Antennas**

The return loss measurements for the first antenna, Rectangular a from computer analysis are as shown in Figure 7.5. The bandwidth for Rectangular a is 4.12% starting from 2.38 GHz to 2.48 GHz. Rectangular b gave the bandwidth of 7.5% from 2.41 GHz to 2.59 GHz; *see* Figure 7.6. The results for both antennas were closed to the requirement and both were fabricated for further investigations. Figure 7.7 shows the return loss measurements comparison for both of the modified antennas.

### 7.2.3 The Pentagonal Patch

The pentagonal patch was calculated from the typical pentagonal patch for producing circularly polarized field dimension as stated in Chapter 6.3. The wavelength,  $\lambda$  is 60 mm and the calculations were carried out with  $\epsilon_r = 4.88$  and height,  $h$  is 1.57 mm. While the width of the ground plane was 50 mm and length was also 50 mm. The patch was designed to radiate at 2.4 GHz, with the bandwidth



from 2.4 GHz to 2.49 GHz. A diagram of the patch is as shown in Figure 7.8. The return loss measurement for pentagonal patch is as shown in Figure 7.9. It gives the bandwidth of 6.13% from 2.37 GHz to 2.52 GHz in computer analysis. This antenna meets the requirement and was fabricated for experimental return loss measurements.

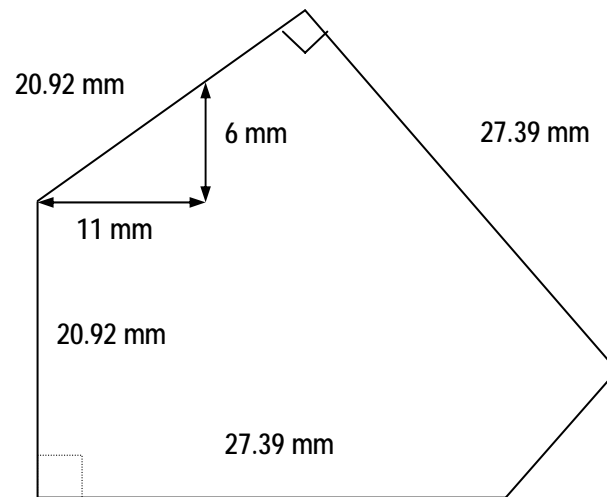

**Figure 7.8 The Pentagonal Patch**

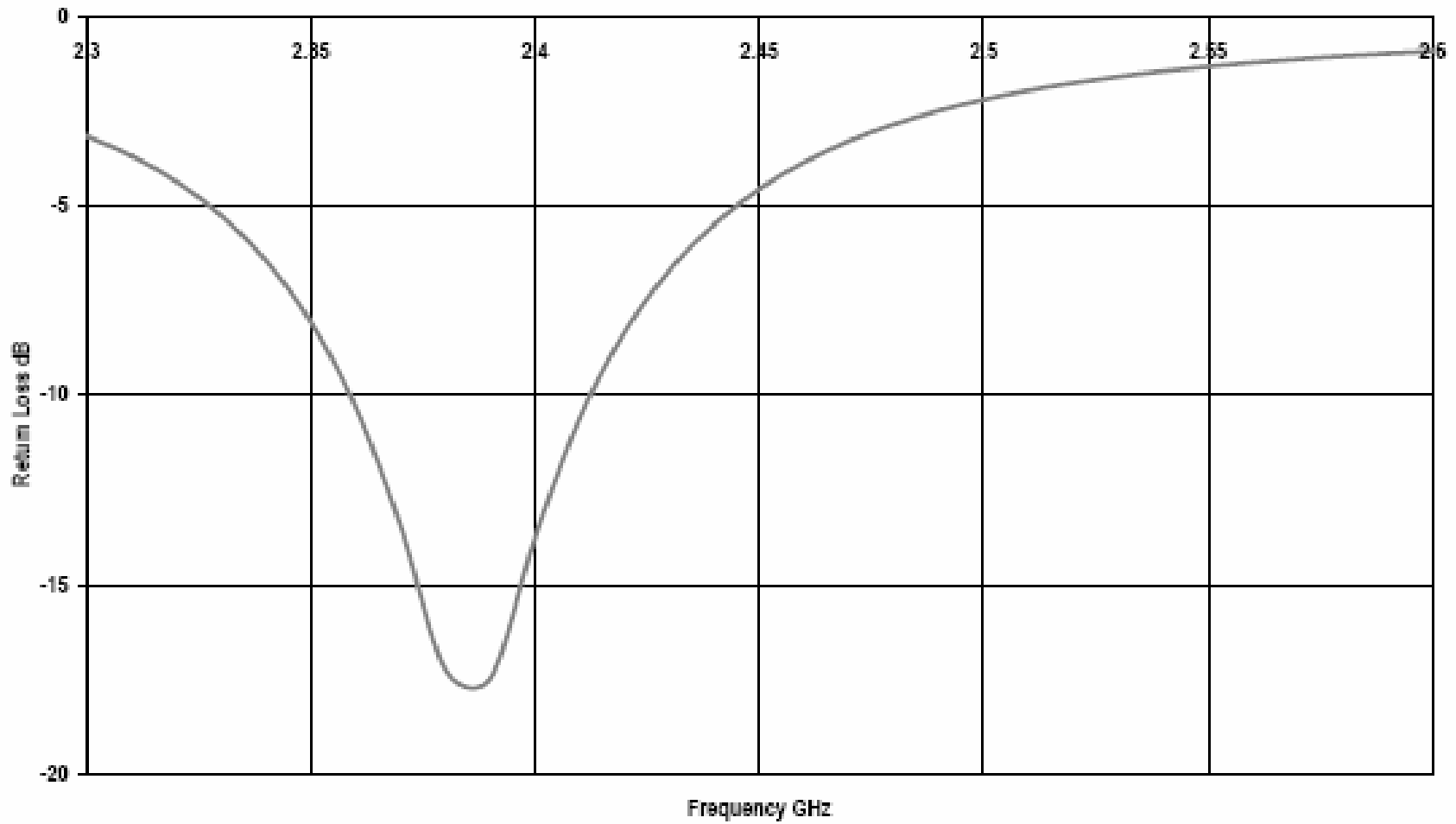

Figure 7.3 Return loss vs Frequency for Calculated Rectangular Patch using Computer Simulation

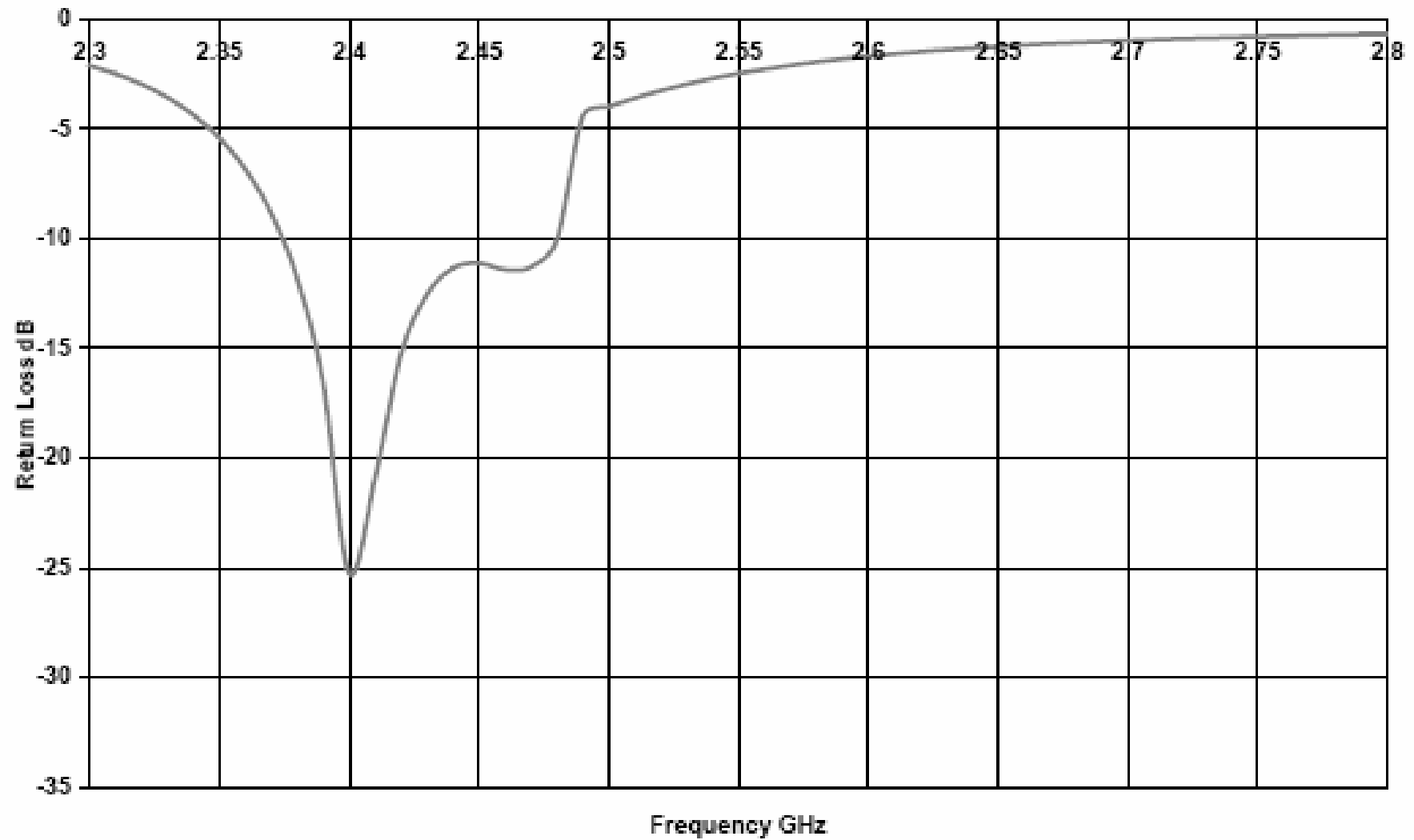

Figure 7.5 Return loss vs Frequency For Rectangular a

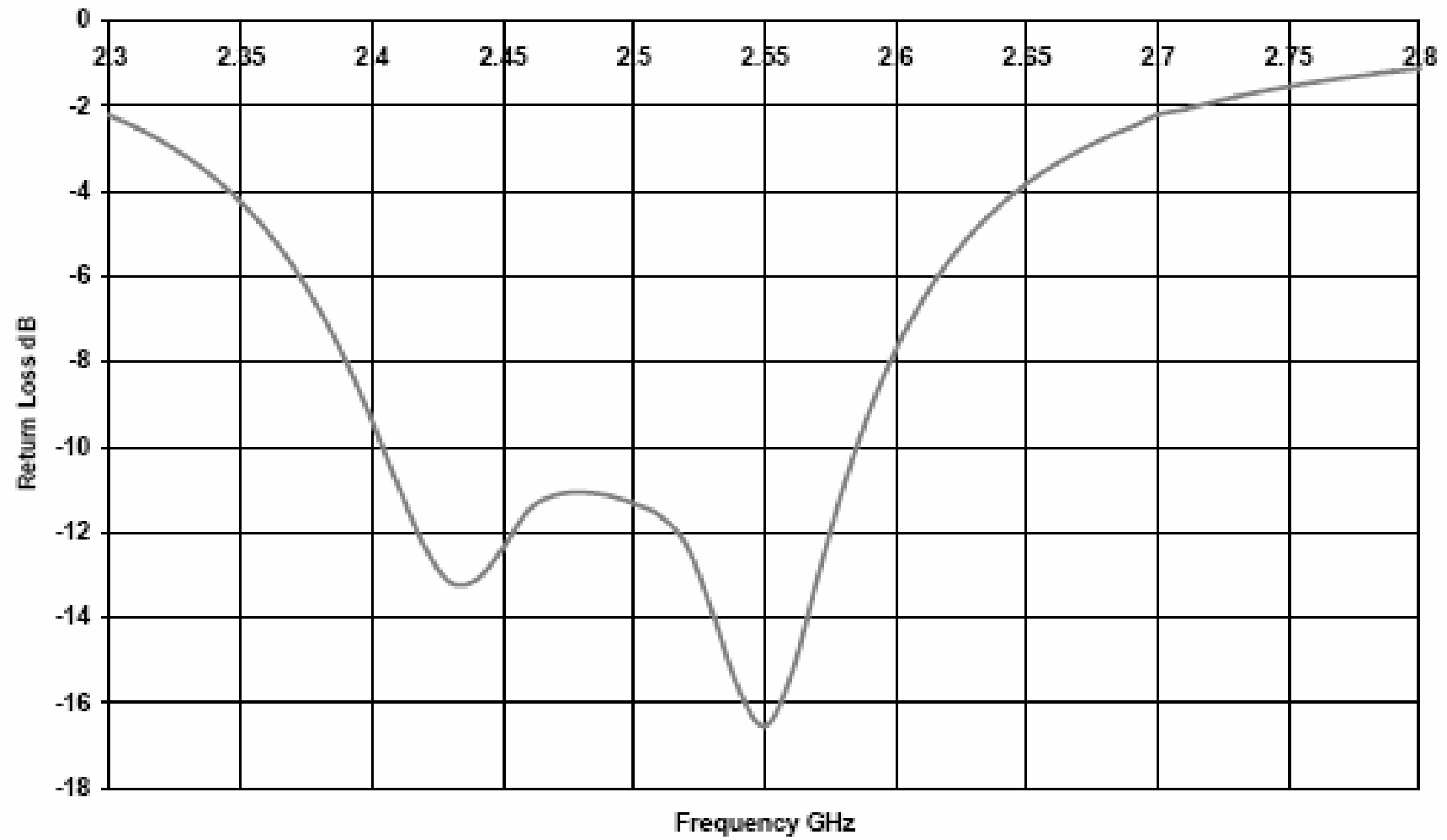

Figure 7.6 Return Loss vs Frequency for Rectangular b

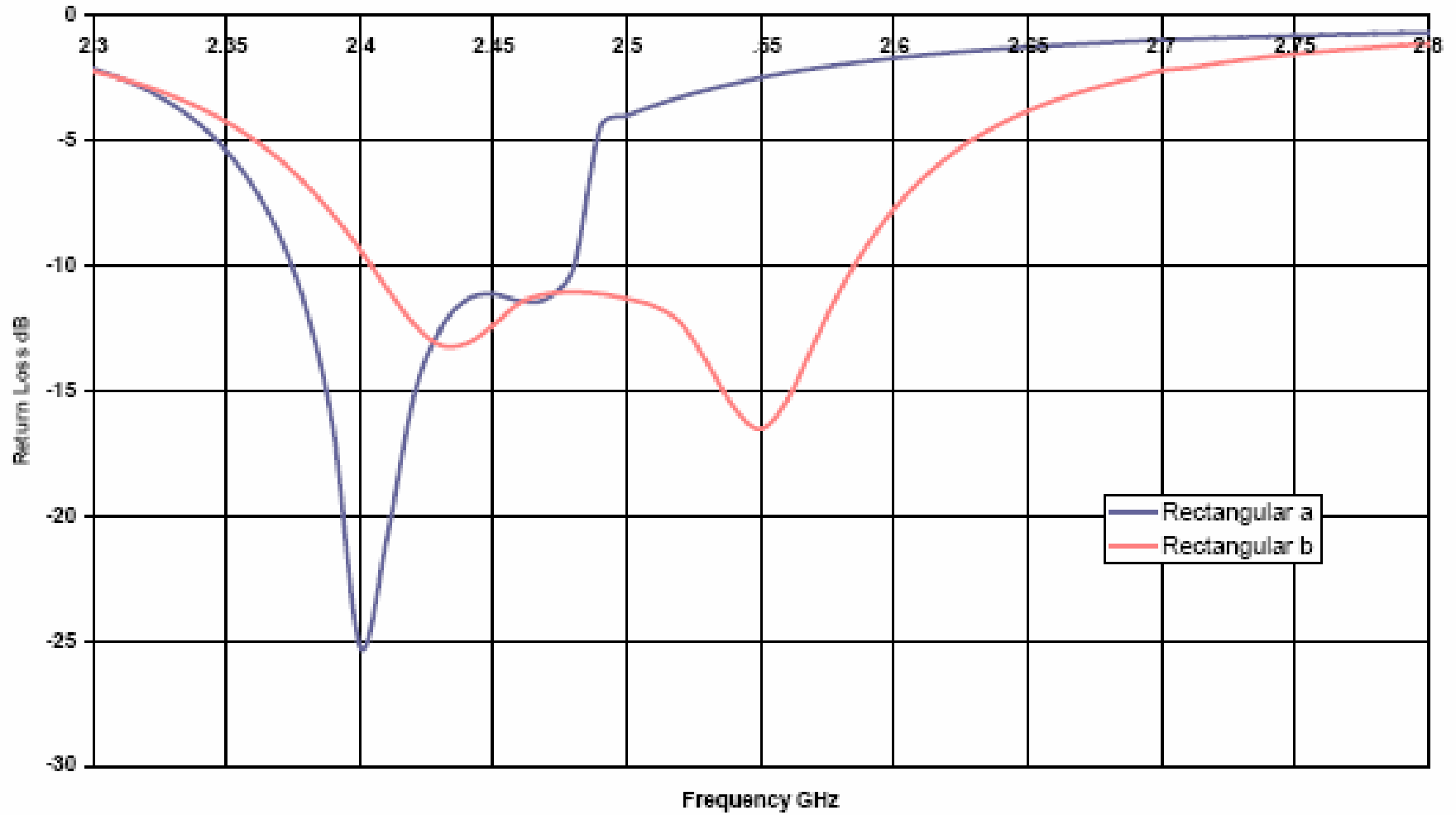

Figure 7.7 Comparison of Return Loss vs Frequency for Rectangular a and b

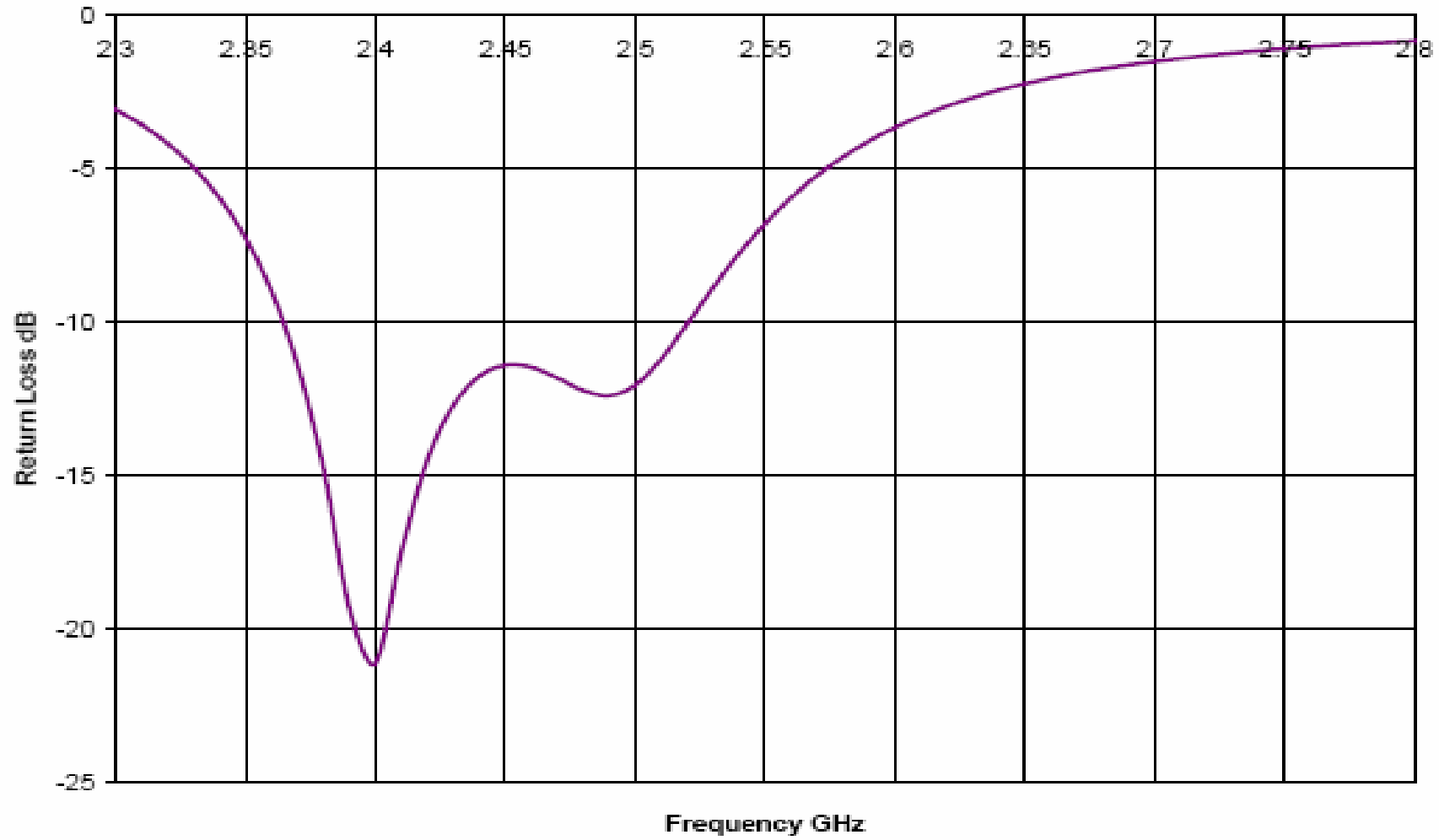

Figure 7.9 Return Loss vs Frequency for Pentagonal Patch

### 7.3 Fabrication

First the mask for etching process was produced. The mask consisted of a film with the patches geometries in jet black and transparent area around them. These films were designed with the aid of AutoCAD R13. All the patches were drawn on a 1:1 scale, thus the dimensions on the screen matched the physical dimensions of the patches. These designs were then printed onto transparent plastic using laser printer for precision.

Woven fiberglass substrate produced by Farnell Corporation was used. The dielectric constant is 4.88 with a dissipation factor of 0.002 and the thickness is 1.57mm. The substrate size for every fabricated antenna is 50 X 50 mm. The film with the template of the antenna was cut into the size of the substrate and removed the protective cover on one side the substrate before taped it securely to it. The protective plastic cover on the substrate must be removed in the dark room because of the photoresist layer on the substrate surface. Exposure to ultraviolet light will soften the photoresist layer. The substrate was then placed face down in the ultraviolet box for four and a half minutes. This is to soften the photoresis that is not covered by the black film in the shape of the patch.

Next, the substrate was dipped in the sodium hydroxide solution (50g in 1 litre of water) for 45 seconds to one minute until the image was developed. The developer washed away the entire photoresist layer that was exposed to the ultraviolet. Therefore, the photoresist had formed a protective layer over the patch leaving the rest of the copper exposed. Then, the substrate was rinsed with tap water and the image of the patch could be seen covered by clear dark yellow layer of photoresist.

To remove the unwanted cooper, substrate then was etched by totally immersing it in Ferric Chloride solution (400g in 1 litre of water) for 45 minutes. The solution was maintained at a temperature of 35 degree Celsius. Next the antenna

was washed in tap water and dried. The protective plastic cover was removed from the ground plane of the antenna and both patch and ground plane were exposed to ultraviolet radiation for another four minutes to soften the photoresist. Then dipped the antenna in developer for 45 seconds to remove the photoresist layer. When it's done, the antenna was washed in the tap water and dried. A hole was drilled on the patch exactly at the port location, to insert the port. Lastly the port was soldered to the patch to keep in place.



## CHAPTER VIII

### EXPERIMENTAL RESULTS

#### 8.1 Return Loss Measurement

A IFR Series 6843 Microwave System Analyzer was used to measure the return loss of the antenna. The set up of the IFR network analyzer is shown in Figure 8.1. The antenna to be investigated is connected to the network analyzer through the fault locator.

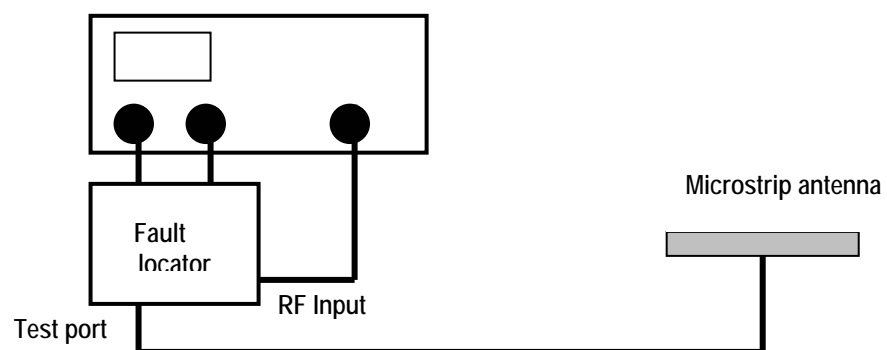
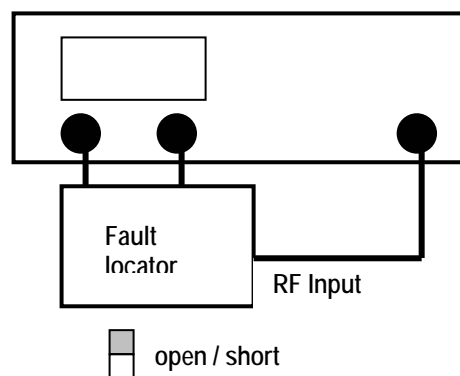

**Figure 8.1 Return and Loss Measurement Set-up**

In order to measure return loss, the system must first be calibrated against a known reference. This was carried out using the calibration set-up and an open/short circuit

as shown in Figure 8.2. The calibration key on the front panel was selected and then follows the instructions given on the screen.

When result was displayed on the screen of the analyzer, it was saved to the floppy disk by selecting the save/recall key. The result was saved into spreadsheet format; therefore the data could be read by Microsoft Excel. This process had the effect of sampling the trace at the maximum of 401 points. Result later was pasted into Excel, edited and reproduced as a return loss versus frequency chart.



**Figure 8.2 Calibration Set-up**

## 8.2 Results for The Fabricated Antennas

After the first stage of the design completed, three microstrip antennas were fabricated; two rectangular patches and a pentagonal antenna. In the computer analysis, the pentagonal antenna gives the best performance because it covers the desired bandwidth of 2.4 GHz and 2.483 GHz. For further analysis three antennas were produced and the return loss measurements for each of the antenna were carried out.

### 8.2.1 Rectangular Antennas

Rectangular antennas of the dimensions given in Figure 7.4 were constructed and tested. Trace of the return loss for both antennas were measured over the frequency range of 2.3 GHz to 2.8 GHz. The comparison between the computer analysis and the experimental results for Rectangular a is as shown in Figure 8.3. The experimental result showed that at  $-10$  dB, the lower frequency shifted to 2.5 GHz, which is 120 MHz from the original 2.38 GHz in computer analysis result. The bandwidth increased slightly from 4.12 % to 4.69% in experimental result.

For Rectangular b, the experimental result also showed a shift of frequency to 2.52 GHz, 110 MHz higher from the computer analysis result. The bandwidth also increased to 7.63%. In Figure 8.4 is the result comparison for Rectangular b. From the experimental results it is clear that both of the rectangular patches did not fulfill the design requirements and need to be redesigned.

### 8.2.2 Pentagonal Patch

A pentagonal patch with the dimensions as shown in Figure 7.8 was produced. As the rectangular patches, a trace of return loss was measured over the frequency range of 2.3GHz to 2.8GHz for this antenna. The comparison between the experimental result and the computer analysis result for pentagonal patch is as shown in Figure 8.5.

In the experimental result for this antenna, the lower frequency at  $-10$  dB moved by 130 MHz to the higher frequency from the computer analysis frequency of 2.37 GHz. The bandwidth however, decreased from 6.3% to 4.69%.

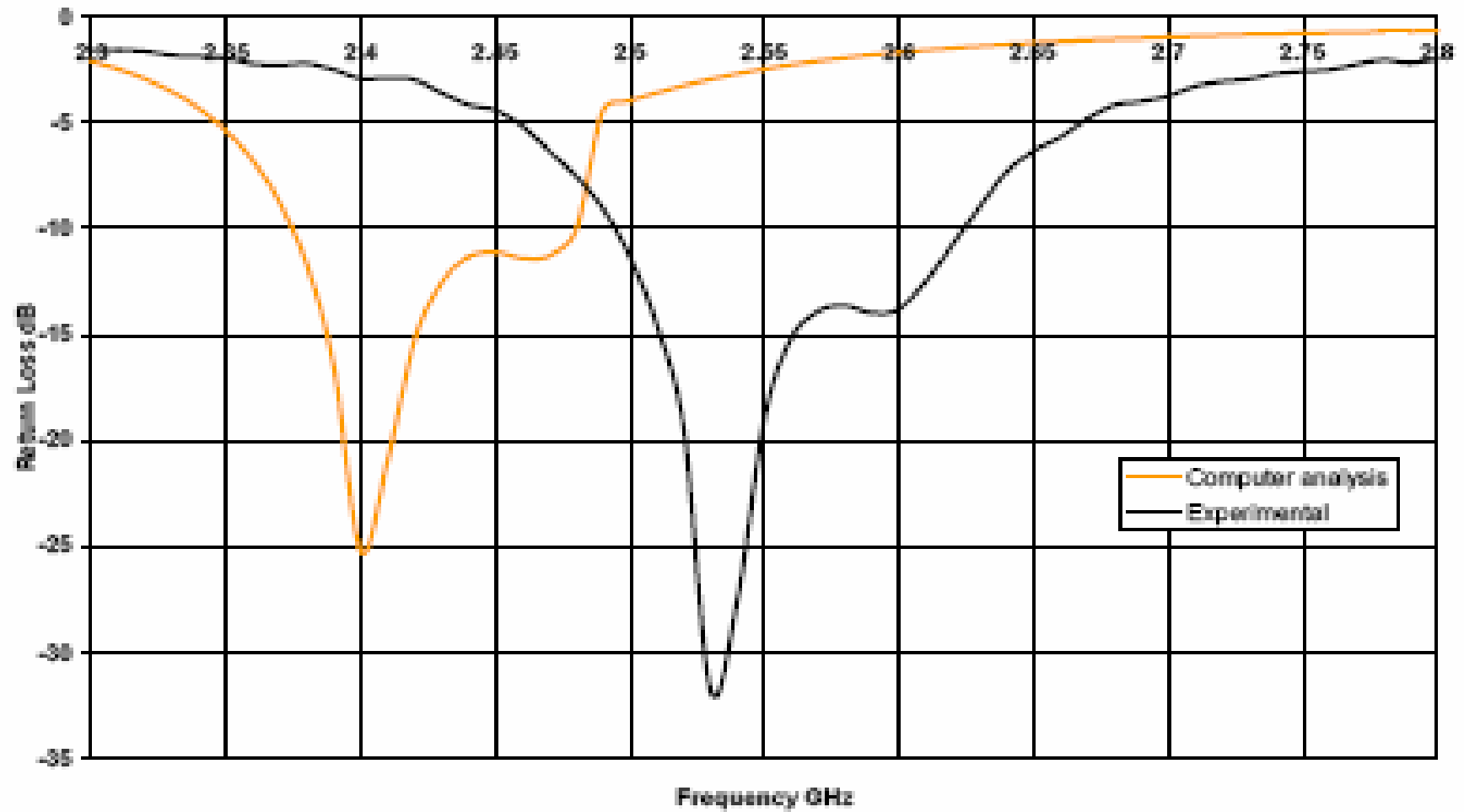

Figure 8.3 Comparison of Return loss vs Frequency Results For Rectangular a

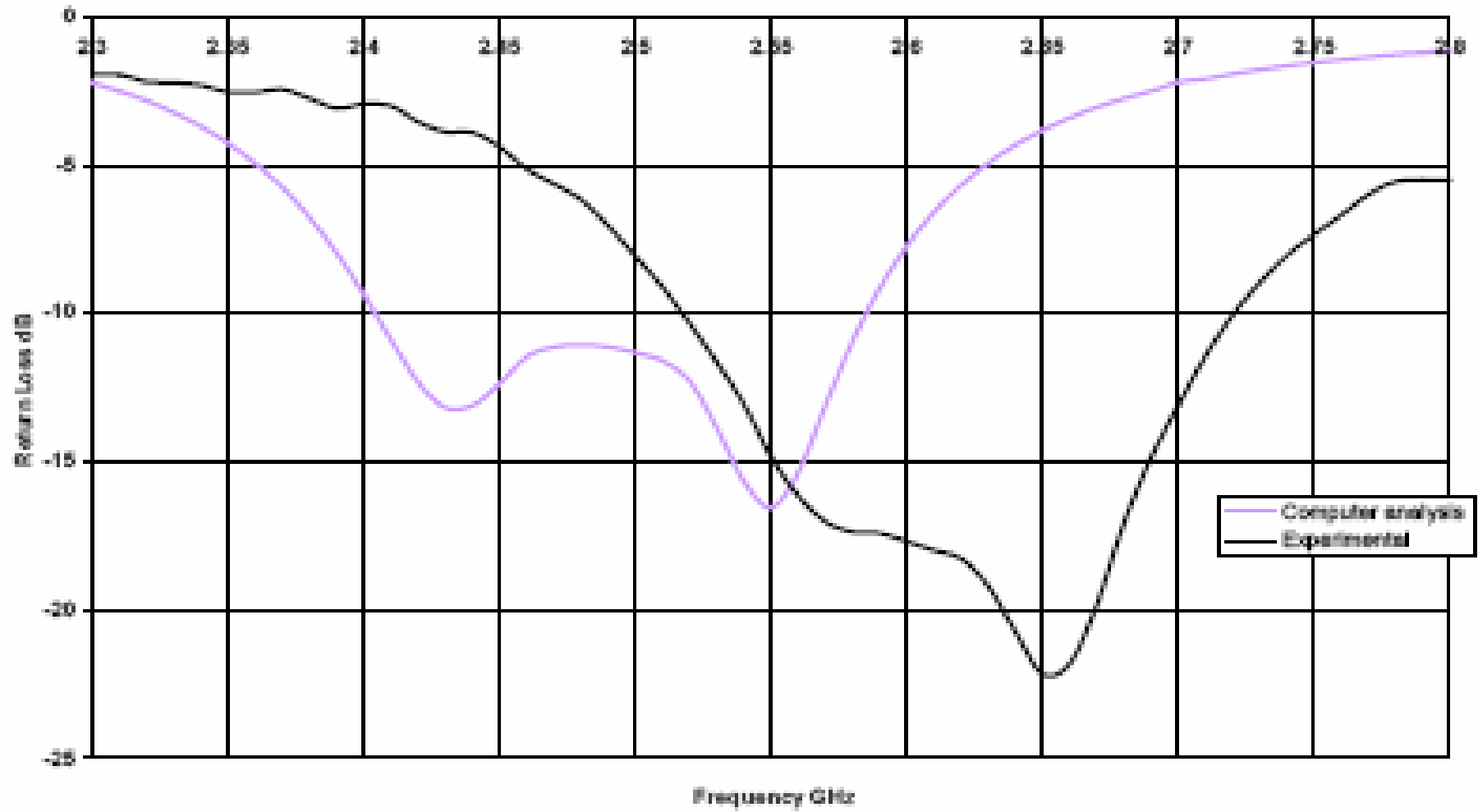

Figure 8.4 Comparison of Return loss vs Frequency For Rectangular b

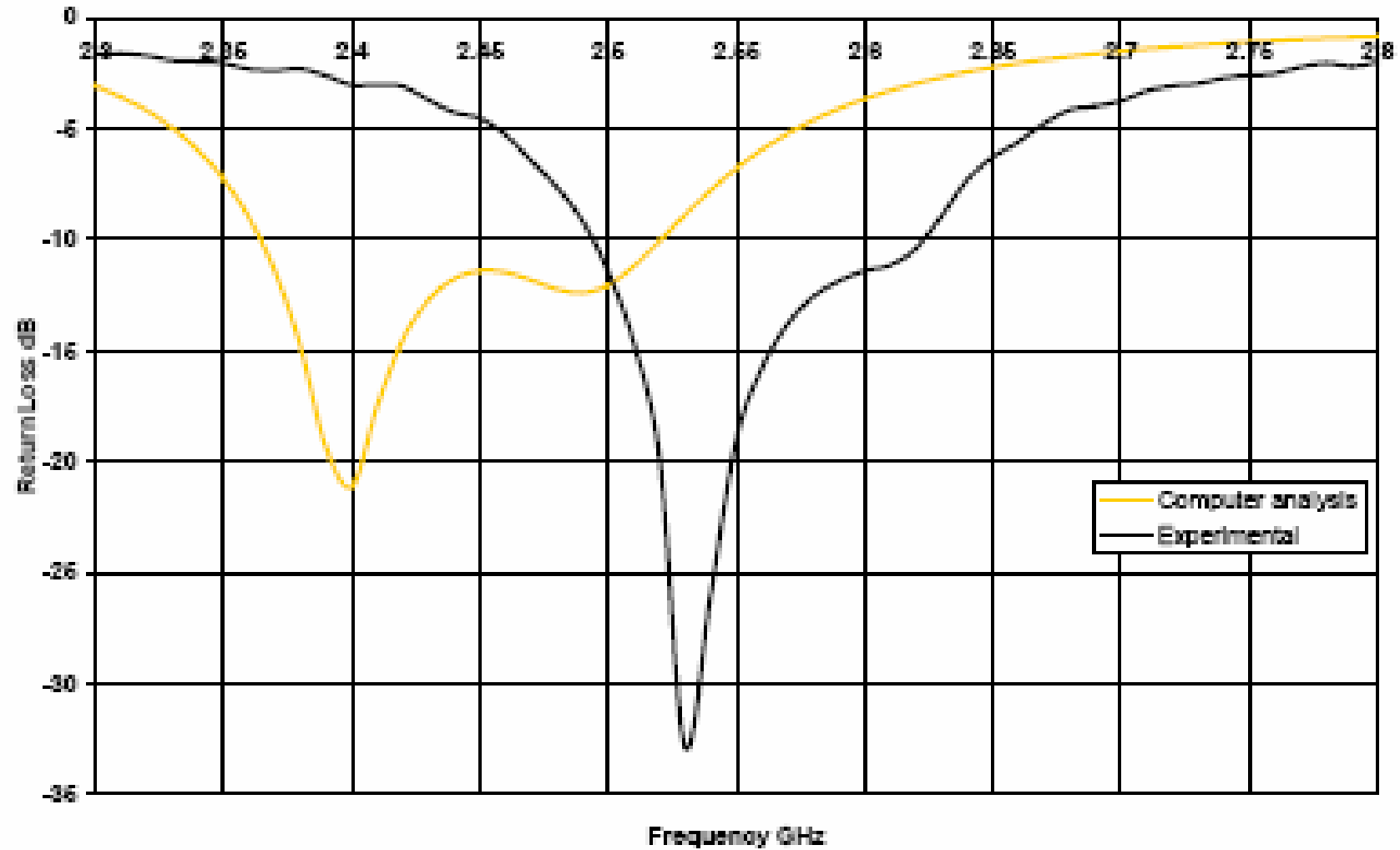

Figure 8.5 Comparison of Return loss vs Frequency For Pentagonal Patch

### 8.3 Discussions

From the experimental results, a significant discrepancy between the computer analysis results and the actual value. It caused the actual frequency shift around 110 MHz to 130 MHz higher from the frequency in the computer simulation.

Since none of the fabricated antennas meets the design requirements, the design process continued. In the next step, adjustment was made to the design. Instead of design the antenna to resonate at the range of 2.4 GHz to 2.483 GHz, the antenna was designed to resonate at around 110 to 130 MHz lower in the computer analysis. It means that the antenna should cover the bandwidth of 2.28 GHz to 2.37 GHz (with tolerance of +/- 100MHz) in computer analysis.

The reasons for error between the computer simulation and actual testing are probably due to the following factors.

1. The antenna enclosure is assumed to be a perfect conductor.
2. Losses at the antenna feed line, a small gap between the probe and substrate will cause impedance shift, thus antenna experienced resonating frequency shift.
3. In computer analysis the probe resistant is not counted for during simulation when there is actually a resistant in probe.

## **CHAPTER IX**

### **DESIGN CORRECTIONS AND RESULTS**

In the second design, correction was made to fix the problem faced by the first design. Due to error between computer analysis and the real antenna analysis, antennas were designed to resonate at 110 MHz to 130 MHz lower in computer simulation. Two rectangular antennas were fabricated and then actual return loss measurements were carried out for each antenna.

#### **9.1 The Corrected Design**

Two rectangular patches were designed at lower frequency to fix the error between the computer simulation and the actual testing. The dimensions for both of the antennas are as illustrated in Figure 9.1 below. Both were constructed on 50 X 50 mm woven fiberglass substrate used in the pervious designs.



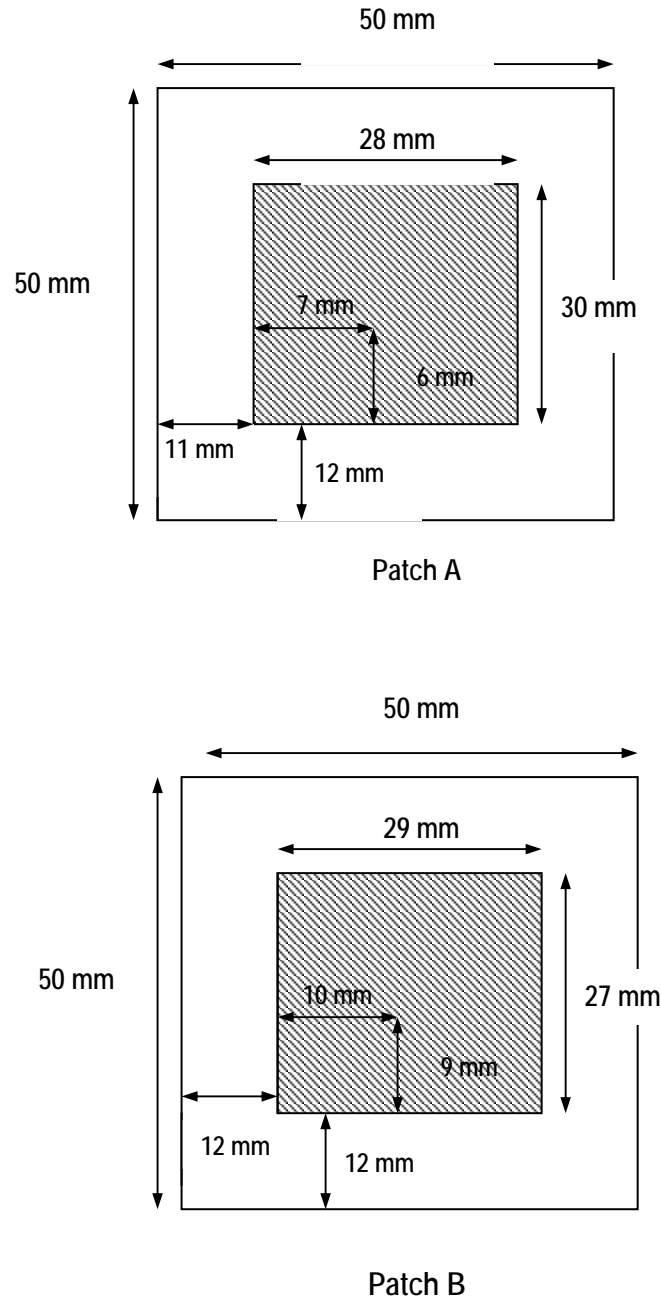

**Figure 9.1 The Corrected Antennas**

Patch A was design to give the bandwidth from 2.2 GHz to 2.41 GHz in computer simulation. Therefore in actual testing this antenna should cover the bandwidth range of 2.3 GHz to 2.51 GHz to achieve the design requirements. In computer analysis Patch B gave the bandwidth from 2.26 GHz to 2.47 GHz. In actual testing it was predicted that this patch should resonate at 2.36 GHz to 2.57 GHz. The

results given by computer analysis for Patch A and B is as shown in Figure 9.2 and Figure 9.3 respectively.

### 9.1.1 Results

After the fabrication was completed both of the antenna were tested for the return loss measurements. The results is as expected, where the antennas resonate at higher frequencies. Patch A resonates with in the frequency of 2.33 GHz to 2.52 GHz and covered the required frequencies for wireless LAN; 2.4 GHz to 2.483 GHz; *see* Figure 9.4. Patch A gave the bandwidth of 7.8%.

Patch B however, resonate at 160 MHz frequency higher than in the result given in computer simulation and missed the 2.4 GHz frequency by 20 MHz. Patch B obtained the bandwidth higher bandwidth that is 8.3% compare to Patch A but did not meet the requirement in term of bandwidth. The comparison of computer analysis result and actual testing for Patch B is as given in Figure 9.5.

Since the design requirement is achieved the design process end here. Patch A was tested for the result repeatability, where two more of the similar antenna were produced and tested. Polarization pattern for Patch A was also obtained to determine the antenna beamwidth.

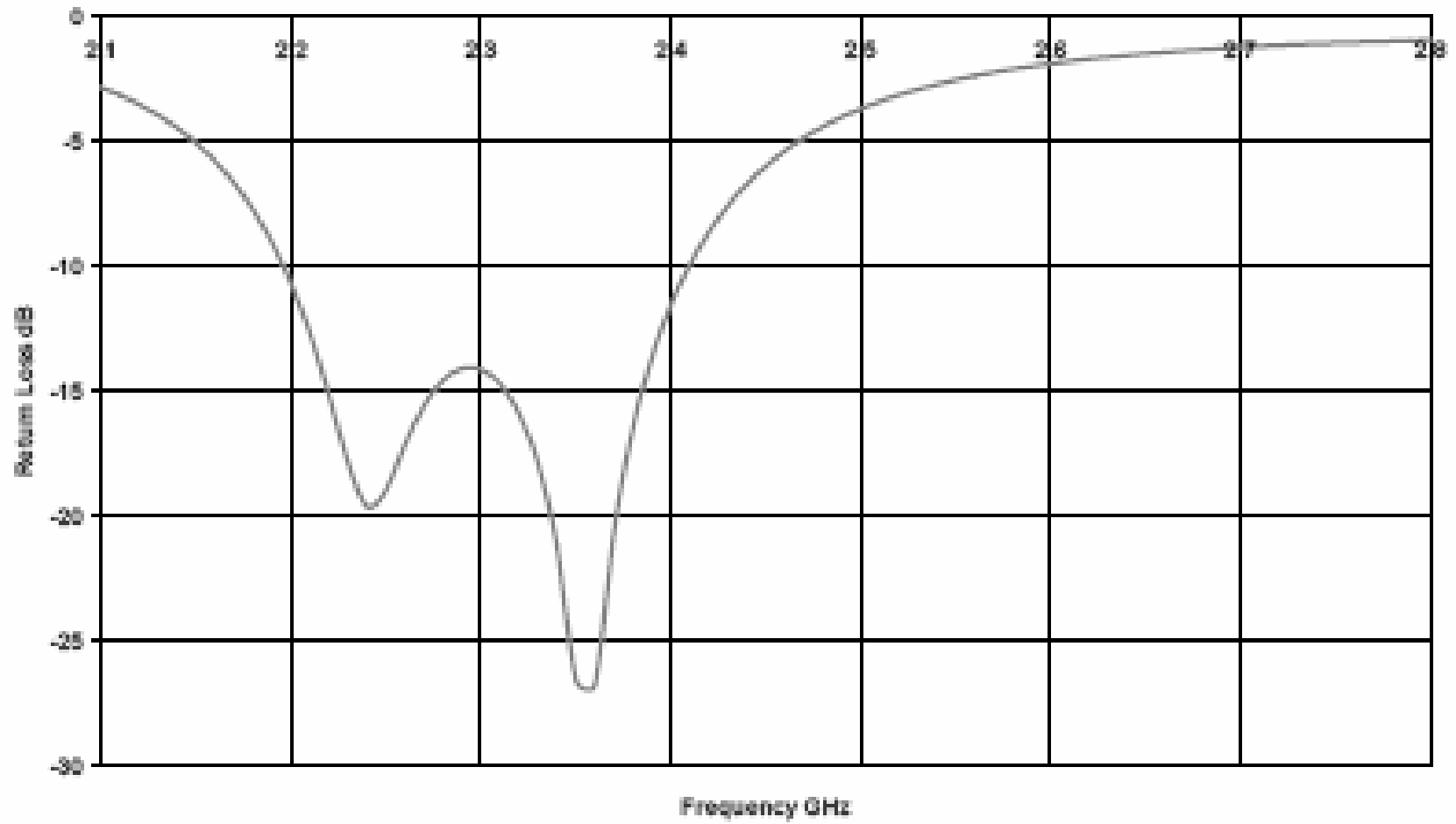

**Figure 9.2 Return Loss vs Frequency for Patch A in Computer Simulation**

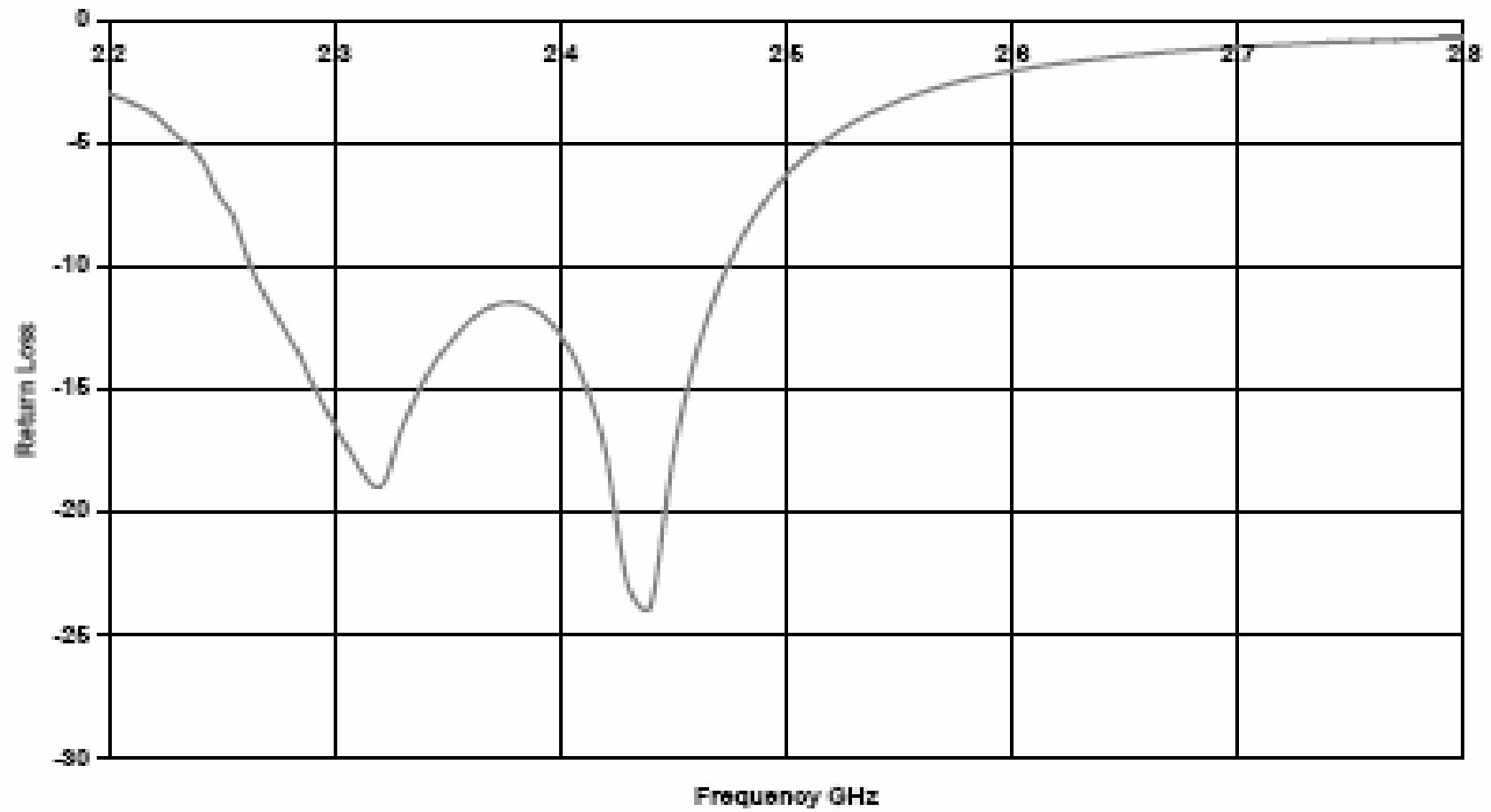

Figure 9.3 Return Loss vs Frequency for Patch b in Computer Simulation

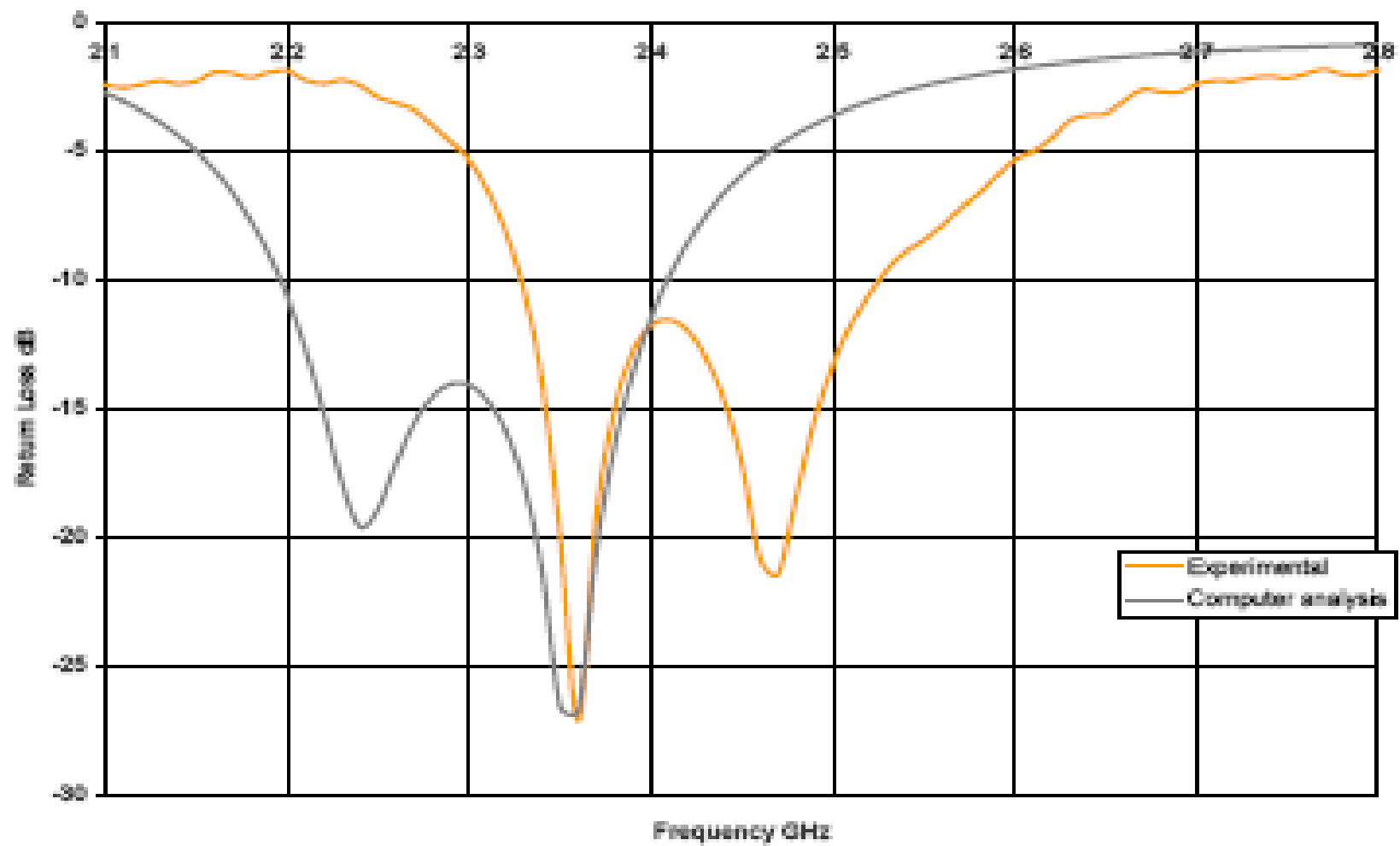

Figure 9.4 Comparison of Return Loss vs Frequency for Patch A.

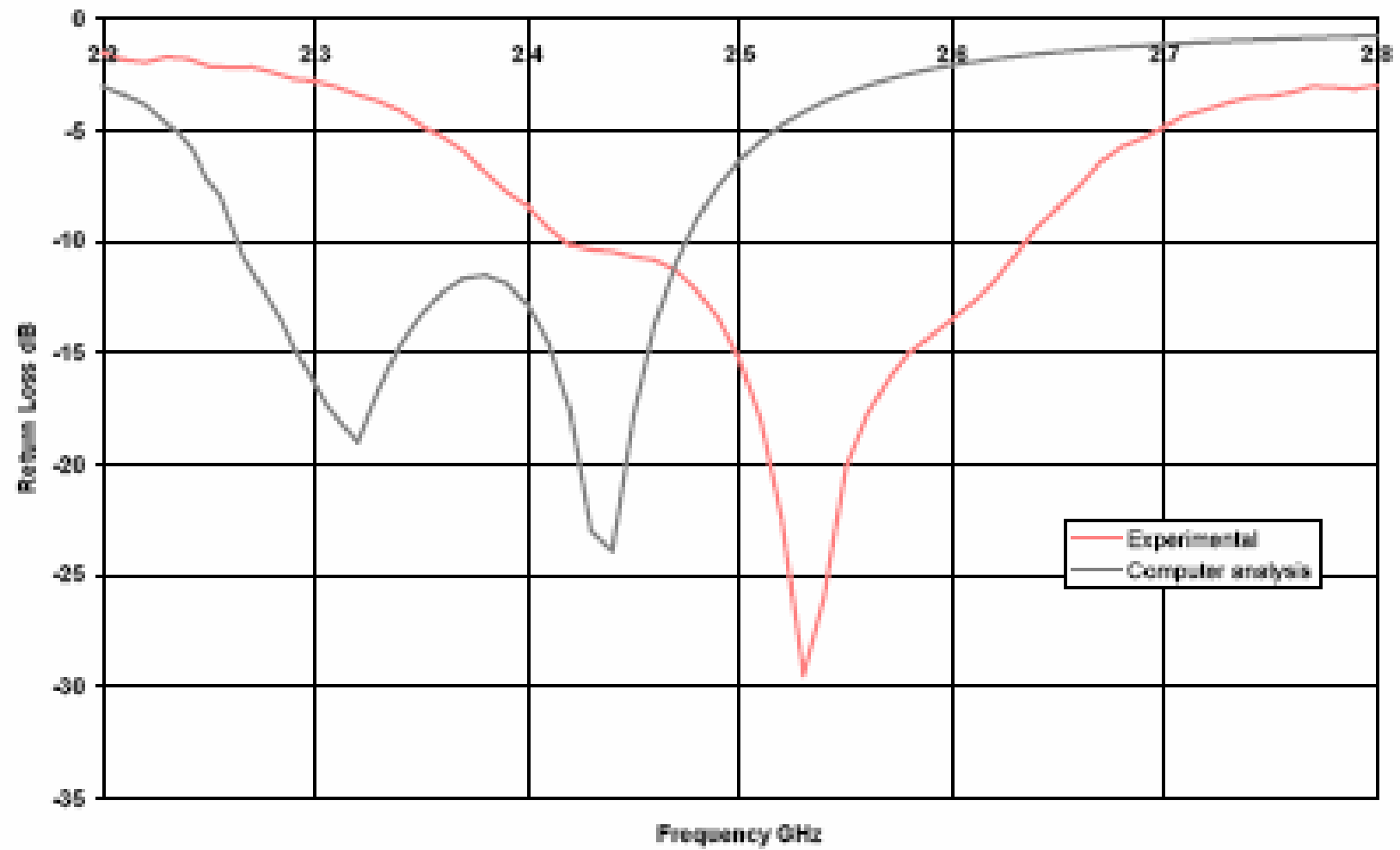

Figure 9.5 Comparison of Return Loss vs Frequency for Patch B

### 9.2.2 Repeatability Test

Repeatability test was carried out to show the result repeatability for Patch A. Another two Patch A antenna were fabricated to accomplish this test, Patch A1 and Patch A2. The antennas were produced at different time to make up for any small variations during the fabrication process. The result obtained for both antennas in comparison to the original patch is given in Figure 9.6.

From the result, return loss measurements for both Patch A1 and A2 is very close to each other, where at certain frequency both antennas give the same readings. Result for Patch A, however appeared to be diverted a little from the rest where the bandwidth is from 2.33-2.52 GHz compare to 2.34-2.53 GHz for Patch A1 and A2. But margin is considered very small that the maximum is only around 0.43 percent. As a conclusion, result that was acquired for Patch A before is repeatable.

### 9.3 Polar Measurements

Standard Yagi antenna, was used to measure the polar pattern of the microstrip antenna. Both Yagi antenna and microstrip antenna were connected to the IFR Series 6843 Microwave System Analyzer. The microstrip antenna was supplied with radio frequency power from the signal source output port of the analyzer. Yagi antenna as connected to the spectrum input port. The Yagi antenna received power from the microstrip patch at a fixed distance,  $L$  for different angles between the antennas, from 0 degrees to 90 degrees. The equipment set-up for polar pattern measurement is as shown in Figure 9.7.

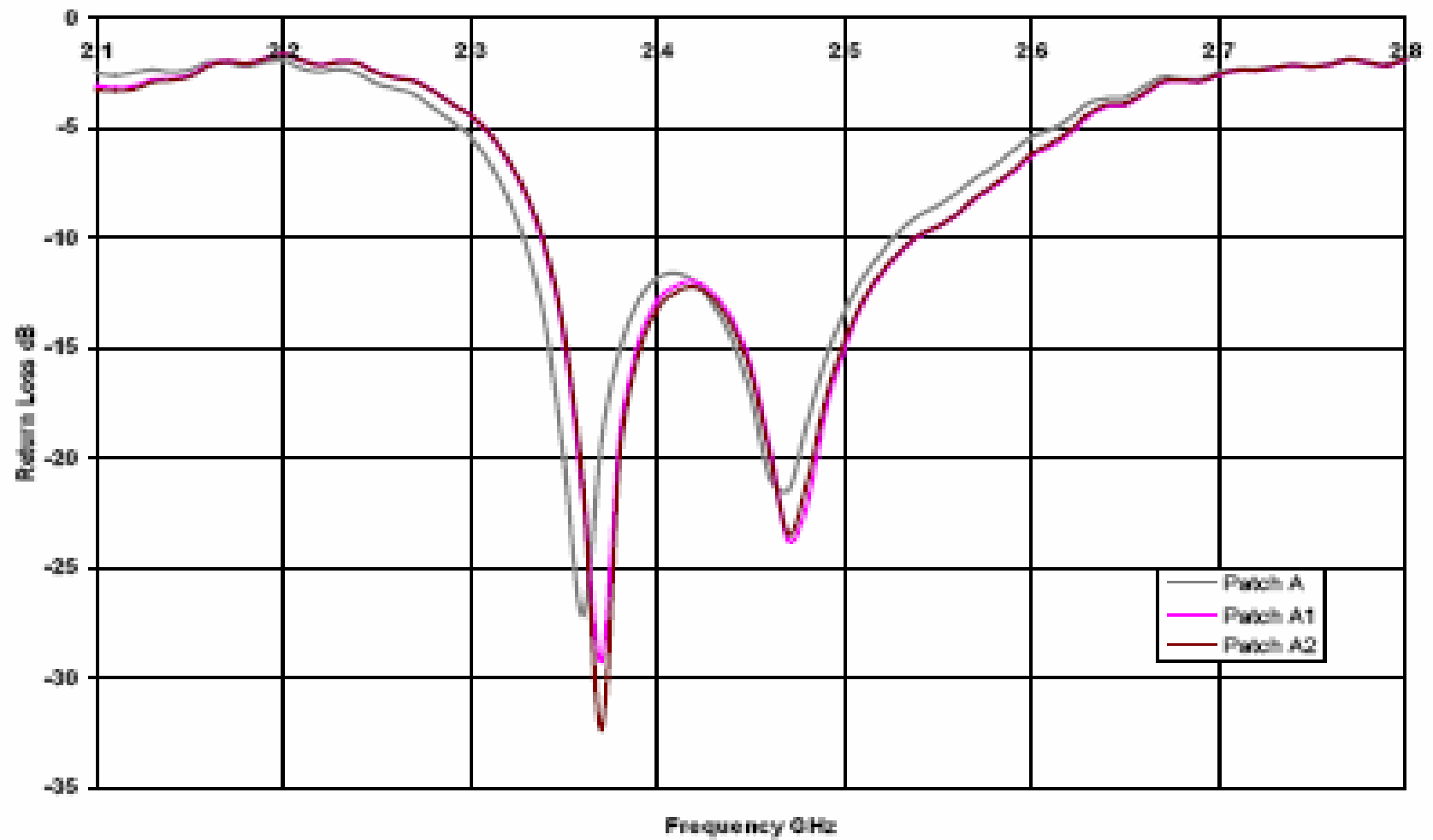
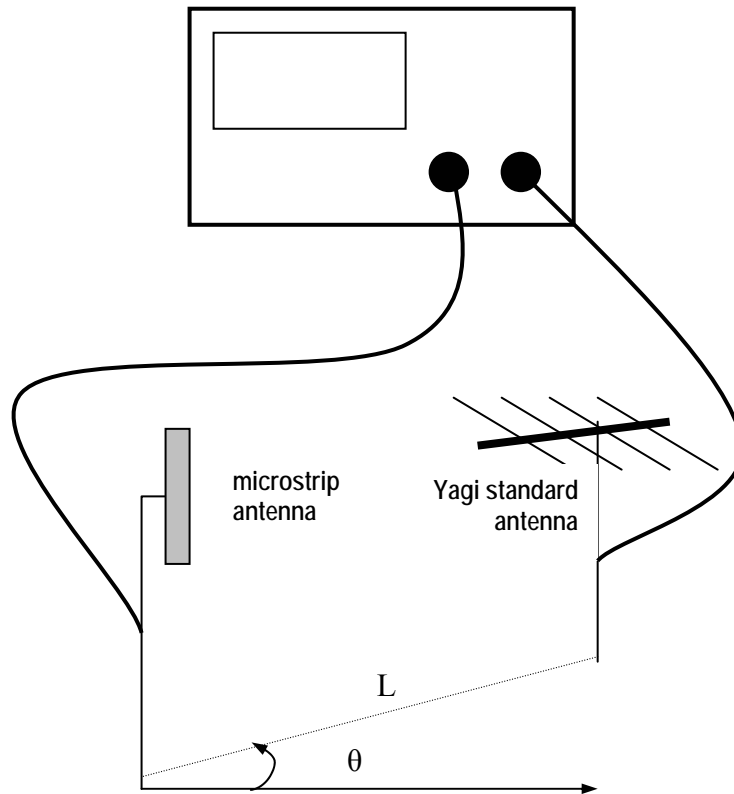

Figure 9.6 Comparison of Return Loss vs Frequency in Repeatability Test

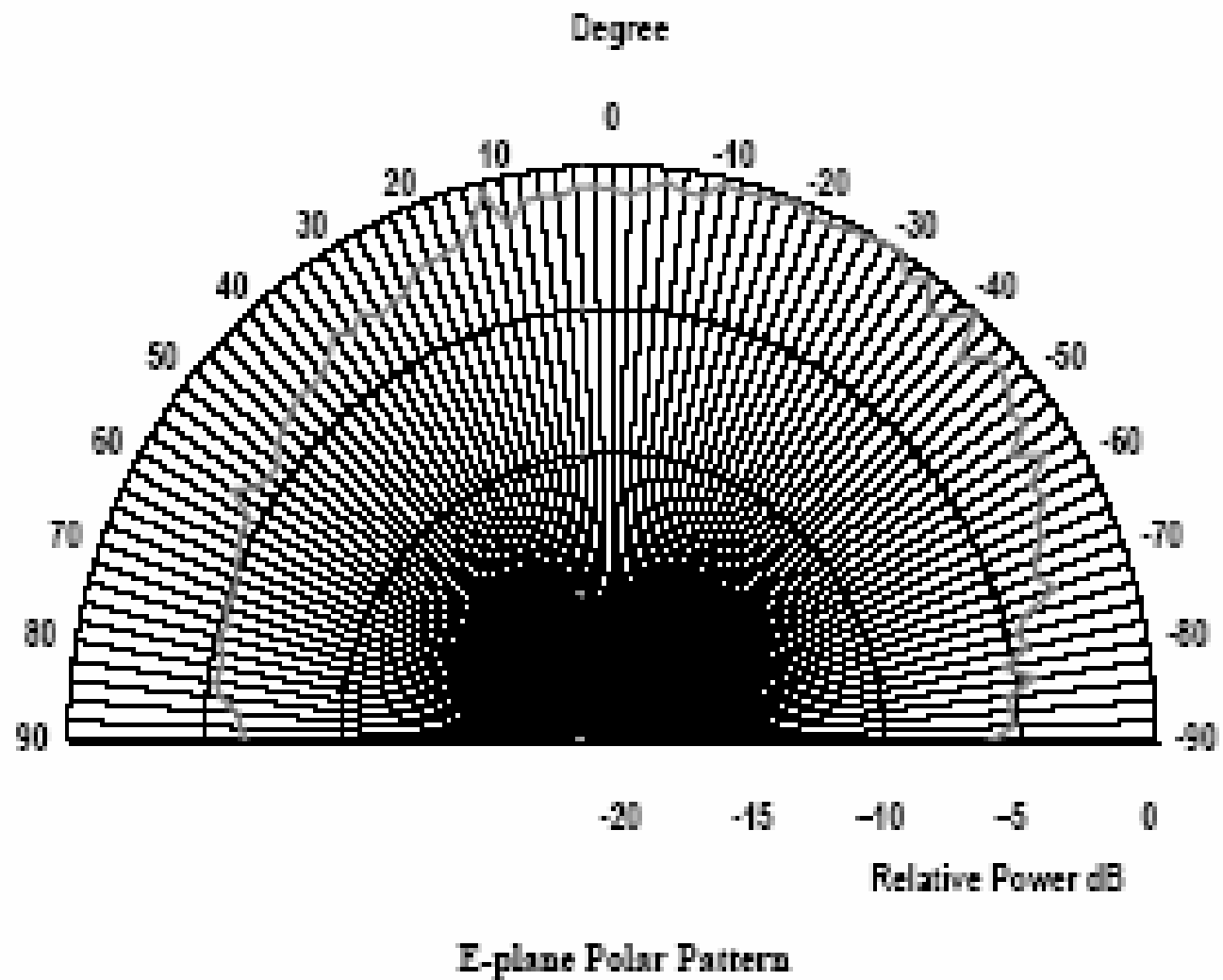



**Figure 9.7 Set-up for Polar Pattern Measurements**

### 9.3.1 Patch A

Polar pattern for Patch A was measured with the distance between the patch and Yagi antenna is 5 feet. The patch's beamwidth in the H-plane is 50 degrees. The polar pattern for Patch A shown in Figure 9.8. Polar pattern for Patch A is not symmetrical, the patch radiate more power on the right side of the patch compare to the left side. Wider beamwidth means the bigger is the antenna coverage, however the directivity is lower thus a lower gain.



## **CHAPTER X**

### **CONCLUSIONS AND SUGGESTIONS FOR FURTHER WORK**

#### **10.1 Conclusions**

This project has been successfully completed where in the end the 2.4 GHz microstrip antenna for wireless LAN applications was designed and produced. A rectangular microstrip patch was constructed on 50 X 50 mm substrate and the feed with coaxial probe. The patch is 30 mm in width, 28 mm in length and the thickness is 1.57 mm. The antenna gave the bandwidth of 7.8% over the frequency range of 2.33 GHz to 2.52 GHz. The E-plane beamwidth obtained by the rectangular patch is 50 degrees. The repeatability test on the results showed that the results obtained in the actual return loss measurements for the antenna is trustworthy.

Due to its small size, lightweight and low volume this antenna is suitable for the wireless LAN applications. For indoor application the antenna could easily blend with the room design and require no major installation that might damage the interior design of the room. A little creativity could turn this small antenna into something that anybody would easily mistaken as a beautiful form of art.

## **10.2 Suggestions For Further Work**

Wider range could be achieved by increasing the antenna gain and this could be achieved by producing the flat array microstrip patch. Since the wireless LAN standard utilized both of the 2.4 GHz and 5 GHz band, then microstrip antenna also can be design to resonate at dual frequency to support both band.

## REFERENCES

1. Bahl, I.J. and Bhartia, P. (1980). "Microstrip antenna." Norwood, USA: Artech House.
2. James, J.R. Hall, P.S. and Wood, C. (1981). "Microstrip Antenna Theory and Design." England: Peter Peregrinus.
3. Stutzman, W.L. and Thiele, G.A. (1998). "Antenna Theory and Design." 2<sup>nd</sup> ed. United States: John Wiley & Sons, Inc.
4. Stutzman, W.L. (1993). "Polarization in Electromagnetic Systems." Norwood, MA: Artech House, Inc.
5. Barnes, S.R. (1996). "Stacked Microstrip Antennas." Cranfield University: MSc Thesis.
6. Geier, J. (1999). "Wireless LANs: Implementing Interoperable Networks." 1<sup>st</sup> ed. USA: Macmillan Technical Publishing.
7. Santamaria, A. and Lopez-Hernandez, F.J. (2001). "Wireless LAN Standard and Applications." Norwood, USA: Artech House.
8. Cherry, M.S. (2003). "Wi-Fi Takes New Turn With Wireless-G." *IEEE Spectrum*. **40**. 12-13.
9. Dahele, J.S. and Lee, K.F. (1987). "On the Resonant Frequencies of the Triangular Microstrip Antenna." *IEEE Trans. On A&P*. **1**. 100-101.
10. Dayem, R.A. (1997). "Mobile data and Wireless LAN technologies." New Jersey: Prentice Hall.

11. Rostamy, Z. and Verma, A.K. (1992). “ Resonant Frequency of Equilateral Triangular Patch Resonator with Superstrate using Modified Wolff Model.” *Proceedings of The 1992 International Symposium on A&P.* **3.** 781.
12. Elahi, A. (2001). “Network Communication Technology.” Albany, USA: Delmar.
13. Grag, V.K. (2002). “Wireless Network evolution: 2G to 3G.” New Jersey: Prentice Hall.
14. Geier, J. (1999). “Wireless LANs: Implementing Interoperable Networks.” 1<sup>st</sup> ed. USA: Macmillan Technical Publishing.
15. Stutzman, W.L. (1993). “Polarization in Electromagnetic Systems.” Norwood, MA: Artech House, Inc.
16. Olver, A.D. (1982). “Basic Properties of Antennas.” in. Rudge, A.W., Milne K., Olver A.D. and Knight P. (Eds.) “The Handbook of Antenna Design.” Vol. 1. London, UK: Peter Peregrinus Ltd. 1-31.

**APPENDIX A**

***PHOTOS***



**PHOTO A THE FIRST DESIGN**



**PHOTO B THE CORRECTED DESIGN ANTENNAS**





**PHOTO C ANTENNAS FOR REPEATABILITY TEST**



**PHOTO D RETURN LOSS MEASUREMENTS SET-UP**



**PHOTO E POLAR PATTERN MEASUREMENT SET-UP**



**PHOTO F MICROSTRIP PATCH MOUNTED ON TRIPOD FOR POLAR  
PATTERN MEASUREMENT**



**PHOTO G STANDARD YAGI ANTENNA FOR POLAR PATTERN  
MEASUREMENT**