

A DECENTRALIZED PROPORTIONAL-INTEGRAL SLIDING MODE TRACKING CONTROLLER FOR A 2 D.O.F ROBOT ARM

BABUL SALAM KSM KADER IBRAHIM¹, SALEHA BAKAR¹, MOHAMAD NOH AHMAD² and JOHARI.H.S. OSMAN²

¹Dept. of Mechatronics and Robotics, Faculty of Electrical & Electronics Engineering, Kolej Universiti Teknologi Tun Hussein Onn, 86400 Parit Raja, Batu Pahat.

Tel: +607-4536467, Fax: +607-4536467, Email: babul@kuittho.edu.my

²Dept. of Robotics and Mechatronics, Faculty of Electrical Engineering, Universiti Teknologi Malaysia, 81310 UTM Skudai

Abstract

Trajectory tracking with high accuracy is a very challenging topic in direct drive robot control. This is due to the nonlinearities and input couplings present in the dynamics of the arm. This paper deals with the tracking control of a class of direct-drive robot manipulators. A robust Proportional-Integral (PI) sliding mode control law is derived so that the robot trajectory tracks a desired trajectory as closely as possible despite the highly non-linear and coupled dynamics. The controller is designed using the decentralized approaches. Application to a two degree of freedom direct drive robot arm is considered.

1 Introduction

Variable Structure Control (VSC) with Sliding Mode Control (SMC) has been widely applied to system with uncertainties and/or input couplings [1]. The idea of the SMC is simple; first the desired system dynamics is defined on sliding mode surface. Then, controller is designed to drive the closed loop system to reach the sliding mode surface. In other words, the desired dynamics of the closed loop system is defined first and the state trajectory of the system is then forced to slide on this surface. This can be done through an appropriate switching of the control structures such that the system state will be attracted and stay there afterwards.

When a system is in the sliding mode, its dynamics is strictly determined by the dynamics of the sliding surfaces and hence insensitive to parameter variations and system disturbances. Nevertheless, the system poses no such insensitivity properties during the reaching phase. Therefore insensitivity cannot be ensured throughout the entire response and the robustness during the reaching phase is normally improved by designing the system in such a way that the reaching phase is as short as possible [1].

A variety of the SMC known as Integral Sliding Mode Control (ISMC) has also been reported in the literature [2]. Different from the conventional SMC design approaches, the order of the motion equation in

ISMC is equal to the order of the original system, rather than reduced by the number of dimension of the control input. Moreover, by using this approach, the robustness of the system can be guaranteed throughout the entire response of the system starting from the initial time instance.

In this paper, the problem of robust tracking for robot manipulator is considered. On the basis of sliding mode control theory, a class of VSC controllers for robust tracking of robot manipulators is proposed under decentralized approaches. It is shown theoretically that for system with matched uncertainties, the tracking error is guaranteed to decrease asymptotically to zero and the system dynamics during the sliding phase can easily be shaped up using any conventional pole placement method.

2 Problem Formulation

Consider the dynamics of the robot as an uncertain composite system S defined by an N interconnected sub-systems $S_i, i = 1, 2, \dots, N$ with each sub-system described by

$$S_i: \dot{x}_i(t) = [A_i + \Delta A_i(t)]x_i(t) + [B_i + \Delta B_i(t)]u_i(t) \quad (1)$$

$$+ \sum_{j=1, j \neq i}^N [A_{ij} + \Delta A_{ij}(t)]x_j(t) + \sum_{j=1, j \neq i}^N [B_{ij} + \Delta B_{ij}(t)]u_j(t)$$

where $x_i(t) \in R^{n_i}, u_i(t) \in R^{m_i}$ represent the state and input of sub-system S_i , respectively. A_i, B_i, A_{ij} and B_{ij} are constant nominal matrices. $\Delta A_i, \Delta A_{ij}, \Delta B_i$ and ΔB_{ij} representing uncertainties present in the system, interconnection, input and coupling matrices, respectively.

The following assumptions are introduced:

- (1) Every state vector $x_i(t)$ can be locally observed;
- (2) There exist continuous functions $H_i(t), H_{ij}(t), E_i(t)$ and $E_{ij}(t)$ such that for all $X \in R^N$ and all t :

$$\Delta A_i(t) = B_i H_i(t) ; \|H_i(t)\| \leq \alpha_{ii}$$

$$\Delta A_{ij}(t) = B_i H_{ij}(t) ; \|H_{ij}(t)\| \leq \alpha_{ij} \quad (2)$$

$$\Delta B_i(t) = B_i E_i(t) ; \|E_i(t)\| \leq \beta_{ii}$$

$$\Delta B_{ij}(t) = B_i E_{ij}(t) ; \|E_{ij}(t)\| \leq \beta_{ij}$$

(3) There exist a Lebesgue function $\Omega_i(t) \in R$:

$$\dot{x}_{di}(t) = A_i x_{di}(t) + B_i \Omega_i(t) \quad (3)$$

where A_i and B_i are the i -th subsystem nominal system and input matrices, respectively;

(4) The pair (A_i, B_i) is controllable.

The state vector of the composite system S is defined as

$$X(t) = [x_1^T(t), x_2^T(t), \dots, x_N^T(t)]^T; x_i(t) \in R^{n_i} \quad (4)$$

Let $X_d(t) \in R^{n_i N}$ be the desired state trajectory:

$$X_d(t) = [x_{d1}^T(t), x_{d2}^T(t), \dots, x_{dN}^T(t)]^T; x_{di}(t) \in R^{n_i} \quad (5)$$

Define the tracking error, $z_i(t)$ as

$$z_i(t) = x_i(t) - x_{di}(t) \quad (6)$$

In view of equations (2), (3) and (6), equation (1) can be written as

$$\begin{aligned} \dot{z}_i(t) = & [A_i + B_i H_i(t)] z_i(t) + B H_i(t) x_{di}(t) \\ & - B_i \Omega_i(t) + [B_i + B_i E_i(t)] u_i(t) \\ & + \sum_{j=1, j \neq i}^N [A_{ij} + B_i H_{ij}(t)] x_j(t) \\ & + \sum_{j=1, j \neq i}^N [B_{ij} + B_i E_{ij}(t)] u_j(t) \end{aligned} \quad (7)$$

Define the local PI sliding surface for S_i as

$$\sigma_i(t) = C_i z_i(t) - \int_0^t [C_i A_i + C_i B_i K_i] z_i(\tau) d\tau \quad (8)$$

where $C_i \in R^{m_i \times n_i}$ and $K_i \in R^{m_i \times n_i}$ are constant matrices. The matrix K_i satisfies

$$\lambda_{\max}(A_i + B_i K_i) < 0 \quad (9)$$

and C_i is chosen such that $C_i B_i$ is nonsingular. For this class of system, the sliding manifold can be described as

$$\sigma(t) = [\sigma_1^T, \sigma_2^T, \dots, \sigma_N^T]^T \quad (10)$$

The control problem is to design a decentralized controller for each sub-system using the PI sliding mode (17) such that the system state trajectory $X_i(t)$ tracks the desired state trajectory $X_{di}(t)$ as closely as possible for all t in spite of the uncertainties and non-linearities present in the system.

3 System Dynamics During Sliding Mode

Differentiating equation (8) and substitute equation (7) into it, and equating the resulting equation to zero gives the equivalent control, $u_{eqi}(t)$:

$$\begin{aligned} u_{eqi}(t) = & -[I_{n_i} + E_i(t)]^{-1} \{ (H_i(t) - K_i) z_i(t) \\ & - \Omega_i(t) + H_i(t) x_{di}(t) \\ & + \sum_{j=1, j \neq i}^N (C_i B_i)^{-1} C_i [A_{ij} + B_i H_{ij}(t)] x_j(t) \\ & + \sum_{j=1, j \neq i}^N (C_i B_i)^{-1} C_i [B_{ij} + B_i E_{ij}(t)] u_j(t) \} \end{aligned} \quad (11)$$

The system dynamics during sliding mode can be found by substituting the equivalent control (11) into the system error dynamics (7):

$$\begin{aligned} \dot{z}_i(t) = & [A_i + B_i K_i] z_i(t) \\ & + [I_{m_i} - B_i (C_i B_i)^{-1} C_i] \{ \sum_{j=1, j \neq i}^N [A_{ij} + B_i H_{ij}(t)] x_j(t) \\ & + \sum_{j=1, j \neq i}^N [B_{ij} + B_i E_{ij}(t)] u_j(t) \} \end{aligned} \quad (12)$$

$$\text{Define } P_{S_i} \triangleq [I_{n_i} - B_i (C_i B_i)^{-1} C_i] \quad (13)$$

where P_{S_i} is a *projection operator* and satisfies the following two equations [2]:

$$C_i P_{S_i} = 0 \quad \text{and} \quad P_{S_i} B_i = 0 \quad (14)$$

In view of assumption (2), then it follows that by the projection property, equation (14) can be reduced as

$$\dot{z}_i(t) = [A_i + B_i K_i] z_i(t) \quad (15)$$

Hence if the matching condition is satisfied, the system error dynamics during sliding mode are independent of the interconnection between the subsystems and couplings between the inputs, and, insensitive to the parameter variations. Equation (15) shows that the error dynamics during sliding mode can be specified by the designer through appropriate choice of the matrix K_i .

4 Sliding Mode Tracking Controller Design

The composite manifold (10) is asymptotically stable in the large, if the following hitting condition is held [3]:

$$\sum_{i=1}^N (\sigma_i^T(t) / \|\sigma_i(t)\|) \dot{\sigma}_i(t) < 0 \quad (16)$$

As a proof, let the positive definite Lyapunov function be

$$V(t) = \sum_{i=1}^N \|\sigma_i(t)\| \quad (17)$$

$$\text{Then } \dot{V}(t) = \sum_{i=1}^N (\sigma_i^T(t) / \|\sigma_i(t)\|) \dot{\sigma}_i(t) \quad (18)$$

Following the Lyapunov stability theory, if equation (16) holds, then the sliding manifold $\sigma(t)$ is asymptotically stable in the large.

Theorem 4.2: The global hitting condition (16) of the composite manifold (10) is satisfied if every local control $u_i(t)$ of the error system (7) is given by:

$$\begin{aligned} u_i(t) = & -(C_i B_i)^{-1} [\gamma_{i1} \|z_i(t)\| + \gamma_{i2} \|x_i(t)\| + \gamma_{i3} \|x_{di}(t)\| \\ & + \gamma_{i4} \|\Omega_i(t)\|] \text{SGN}(\sigma_i(t)) + \Omega_i(t) \end{aligned} \quad (19)$$

where

$$\gamma_{i1} > \frac{\alpha_{ii} \|C_i B_i\| + \|C_i B_i K_i\|}{\{(1 + \beta_{ii}) \|C_i B_i\| + \sum_{j=1, j \neq i}^N [\|C_j B_{ji}\| + \beta_{ji} \|C_j B_j\|]\} (C_i B_i)^{-1}} \quad (20)$$

$$\gamma_{i2} > \frac{\sum_{j=1, j \neq i}^N \|C_j A_{ji}\| + \alpha_{ji} \|C_j B_j\|}{\{(1 + \beta_{ii}) \|C_i B_i\| + \sum_{j=1, j \neq i}^N [\|C_j B_{ji}\| + \beta_{ji} \|C_j B_j\|]\} (C_i B_i)^{-1}} \quad (21)$$

$$\gamma_{i3} > \frac{\alpha_{ii} \|C_i B_i\|}{\{(1 + \beta_{ii}) \|C_i B_i\| + \sum_{j=1, j \neq i}^N [\|C_j B_{ji}\| + \beta_{ji} \|C_j B_j\|]\} (C_i B_i)^{-1}} \quad (22)$$

$$\gamma_{i4} > \frac{\beta_{ii} \|C_i B_i\| + \sum_{j=1, j \neq i}^N [\|C_j B_{ji}\| + \beta_{ji} \|C_j B_j\|]}{\{(1 + \beta_{ii}) \|C_i B_i\| + \sum_{j=1, j \neq i}^N [\|C_j B_{ji}\| + \beta_{ji} \|C_j B_j\|]\} (C_i B_i)^{-1}} \quad (23)$$

Proof: See [4].

It is shown in [4] that the system (1) is stable in the sense of Lyapunov if the system is control by the input (19). The structure of the Decentralized Integral Sliding Mode Controller is shown in Figure 1.

5 Simulation Example

Consider a two-link manipulator with rigid links of nominally equal length l and mass m shown in Figure 2. The dynamics of the manipulator is [5]:

$$\begin{bmatrix} \tau_1 \\ \tau_2 \end{bmatrix} = \begin{bmatrix} 2.351 + 0.168 \cos(q_2) & 0.102 + 0.084 \cos(q_2) \\ 0.102 + 0.084 \cos(q_2) & 0.102 \end{bmatrix} \begin{bmatrix} \ddot{q}_1 \\ \ddot{q}_2 \end{bmatrix} +$$

$$\begin{bmatrix} -0.168 \sin(q_2) \dot{q}_2 + b_1 + \frac{f_{c1} \operatorname{sgn}(\dot{q}_1)}{\dot{q}_1} & -0.084 \sin(q_2) \dot{q}_2 \\ 0.084 \sin(q_2) \dot{q}_1 & b_2 + \frac{f_{c2} \operatorname{sgn}(\dot{q}_2)}{\dot{q}_2} \end{bmatrix} \begin{bmatrix} \dot{q}_1 \\ \dot{q}_2 \end{bmatrix} +$$

$$+ \begin{bmatrix} \frac{38.465 \sin(q_1) + 1.8247 \sin(q_1 + q_2)}{q_1} \\ \frac{1.8247 \sin(q_1 + q_2)}{x_1} \end{bmatrix} [q_1] \quad (24)$$

Define

$$X(t) \triangleq [x_1 \ x_2 \ x_3 \ x_4 \ x_5 \ x_6]^T = [q_1 \ \dot{q}_1 \ \ddot{q}_1 \ q_2 \ \dot{q}_2 \ \ddot{q}_2] \quad (25)$$

$$U(t) \triangleq [u_1 \ u_2]^T \quad (26)$$

Then the plant can be represented in the form of

$$\dot{X}(t) = A(x)X(t) + B(x)U(t) \quad (27)$$

where,

$$A = \begin{bmatrix} 0 & 1 & 0 & 0 & 0 & 0 \\ 0 & 0 & 1 & 0 & 0 & 0 \\ a_{31} & a_{32} & a_{33} & 0 & a_{35} & a_{36} \\ 0 & 0 & 0 & 0 & 1 & 0 \\ 0 & 0 & 0 & 0 & 0 & 1 \\ a_{61} & a_{62} & a_{63} & 0 & a_{65} & a_{66} \end{bmatrix} \text{ and } B = \begin{bmatrix} 0 & 0 \\ 0 & 0 \\ b_{31} & b_{32} \\ 0 & 0 \\ 0 & 0 \\ b_{61} & b_{62} \end{bmatrix} \quad (28)$$

the nonzero elements of matrices A and B are shown in the Appendix.

Suppose that the bounds of the $\theta_i(t)$ and $\dot{\theta}_i(t)$ are:

$$0^\circ \leq \theta_1 \leq 55^\circ, \quad 0^\circ \text{ s}^{-1} \leq \dot{\theta}_1 \leq 150^\circ \text{ s}^{-1}, \quad (29)$$

$$0^\circ \leq \theta_2 \leq 185^\circ, \quad 0^\circ \text{ s}^{-1} \leq \dot{\theta}_2 \leq 438^\circ \text{ s}^{-1}$$

It is assumed that each sub-system is required to track a pre-specified cycloidal function of the form:

$$\theta_{di}(t) = \begin{cases} \theta_i(0) + \frac{\Delta_i}{2\pi} \left[\frac{2\pi}{\tau} - \sin\left(\frac{2\pi}{\tau} t\right) \right], & 0 \leq t \leq \tau \\ \theta_i(\tau), & \tau \leq t \end{cases} \quad (30)$$

where $\Delta_i = \theta_i(\tau) - \theta_i(0)$, $i=1,2$. In this example, the input trajectory data used are as follows:

Start time, $t(0) = 0.0$ s

Final time, $\tau = 10.0$ s

Start positions, $\theta_1(0) = 10$ deg ; $\theta_2(0) = 15$ deg

Final positions, $\theta_1(\tau) = 50$ deg ; $\theta_2(\tau) = 60$ deg

6 Results and Discussion

With the given bounds, the plant can be represented in the form of equation (1). Each joint of the robot is treated as a sub-system with the nominal value of A_i , A_{ij} , B_i and B_{ij} is calculated as:

$$A_1 = \begin{bmatrix} 0 & 1 & 0 \\ 0 & 0 & 1 \\ -10.46 & -1.66 & -4.55 \end{bmatrix}; \quad A_2 = \begin{bmatrix} 0 & 1 & 0 \\ 0 & 0 & 1 \\ 0 & -0.081 & -0.135 \end{bmatrix}$$

$$A_{12} = \begin{bmatrix} 0 & 0 & 0 \\ 0 & 0 & 0 \\ 0 & -0.0034 & 0.1383 \end{bmatrix}; \quad A_{21} = \begin{bmatrix} 0 & 0 & 0 \\ 0 & 0 & 0 \\ 0.974 & 0.0996 & 0.2913 \end{bmatrix}$$

$$B_1 = \begin{bmatrix} 0 \\ 0 \\ 0.55 \end{bmatrix}; \quad B_2 = \begin{bmatrix} 0 \\ 0 \\ 0.934 \end{bmatrix};$$

$$B_{12} = \begin{bmatrix} 0 \\ 0 \\ -0.0179 \end{bmatrix}; \quad B_{21} = \begin{bmatrix} 0 \\ 0 \\ -0.0365 \end{bmatrix}$$

Using equation (2), the bounds of $H_i(t)$ and $E_i(t)$ can be computed:

$$\|H_1(t)\| \leq \alpha_1 = 9.838, \quad \|H_2(t)\| \leq \alpha_2 = 0.0225;$$

$$\|H_{12}(t)\| \leq \alpha_{12} = 9.4715 \quad \|H_{21}(t)\| \leq \alpha_{21} = 103.2895$$

$$\|E_1(t)\| \leq \beta_1 = 0.0302 \quad \|E_2(t)\| \leq \beta_2 = 0.0021$$

$$\|E_{12}(t)\| \leq \beta_{12} = 0.8101 \quad \|E_{21}(t)\| \leq \beta_{21} = 0.811$$

In this study, the gains are chosen as follows:

$$K_1 = [-10.8423 \quad 13.3527 \quad 1.7282] \text{ so that}$$

$$\lambda(A_1 + B_1 K_1) = \{-1, -1.5, -3\};$$

$K_2 = [4.8175 \quad 9.5482 \quad 5.7435]$ so that

$\lambda(A_2 + B_2K_2) = \{-1, -1.5, -3\}$; and

$C_1 = [25 \quad 15 \quad 1]$ and $C_2 = [3 \quad 2 \quad 1]$

Therefore, from equations (20)-(23):

$\gamma_{11} > 6.0253$; $\gamma_{12} > 4.1263$; $\gamma_{13} > 2.1853$; $\gamma_{14} > 0.3276$;

$\gamma_{21} > 7.5837$; $\gamma_{22} > 0.1006$; $\gamma_{23} > 0.0140$; $\gamma_{24} > 0.3105$

For simulation purposes, two sets of controller parameters are chosen:

Set1:

$\gamma_{11} = 0.5$; $\gamma_{12} = 0.5$; $\gamma_{13} = 0.1$; $\gamma_{14} = 0.04$;

$\gamma_{21} = 4$; $\gamma_{22} = 0.1$; $\gamma_{23} = 0.01$; $\gamma_{24} = 0.2$

Set2:

$\gamma_{11} = 8$; $\gamma_{12} = 6$; $\gamma_{13} = 3$; $\gamma_{14} = 0.45$;

$\gamma_{21} = 10$; $\gamma_{22} = 0.2$; $\gamma_{23} = 0.02$; $\gamma_{24} = 0.9383$

Set 1 contains the controller parameter selected to study the performance of the system if equations (20)-(23) are not met; while Set 2 contains the parameters satisfying the condition imposed on the controller are met. It can be seen that the tracking performance for both subsystems when Set 1 parameters were used are unsatisfactory (Figures 3a and 3b). The simulation was run again but this time with the decentralized controller parameter was supplied from Set 2 (Figures 3c and 3d). As predicted theoretically, the tracking performance is good for both subsystems.

6 Conclusions

Precise trajectory tracking is important in the robotic control. In this project, a Decentralized Integral Sliding Mode controller is designed and used to track the desired trajectory of direct drive robot arm. It is shown mathematically that the error dynamics during sliding mode is stable and can easily be shaped-up using the conventional pole-placement technique. Besides, the system stability is also guaranteed during the reaching phase. Application to a two degree of freedom direct drive robot arm shows that this controller is a reliable solution to a robust tracking problem of uncertain dynamical systems.

References

- [1]. Utkin, V., and Shi, J., Integral Sliding Mode in Systems Operating under Uncertainty Conditions, *Proc. IEEE Conf. Decision and Control*, Kobe, Japan, 1996, pp. 4591-4596.
- [2]. Edwards, C., and Spurgeon, S. K., *Sliding Mode Control: Theory and Applications*, Taylor & Francis, 1998.

- [3]. Yan, J. -J, Tsai, J. S-H, Kung, F.-C., Robust Decentralized Stabilization of Large-Scale Delay Systems Via Sliding Mode Control, *Trans. ASME*, Vol. 119, 1997, pp. 307-312.
- [4]. Mohamad Noh Ahmad, "Modelling And Control Of Direct Drive Robot Manipulators", PhD Thesis, 2003, Universiti Teknologi Malaysia.
- [5]. Fernando Reyes and Rafeal Kelly, "Experimental Evaluation of Model-based Controller on a Direct-drive Robot Arm." *Mechatronics*, Vol 11, 2001, pp. 267-282

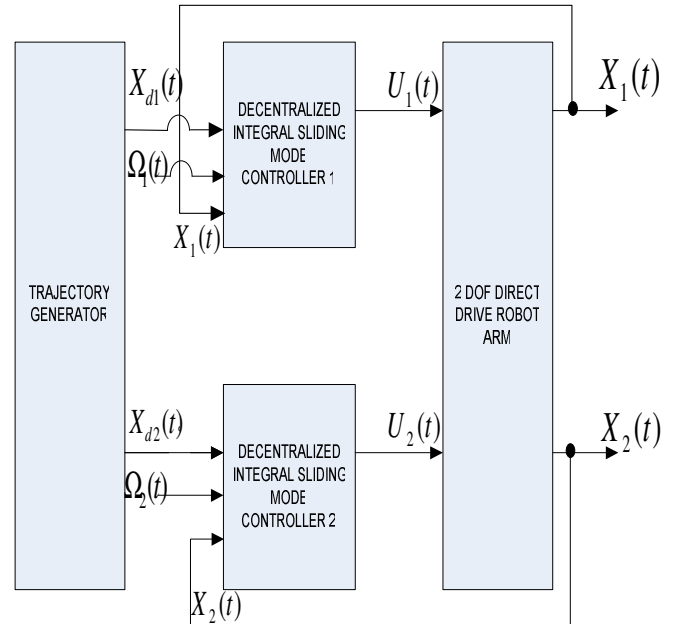

Figure 1: Block Diagram of Decentralized Integral Sliding Mode Controller

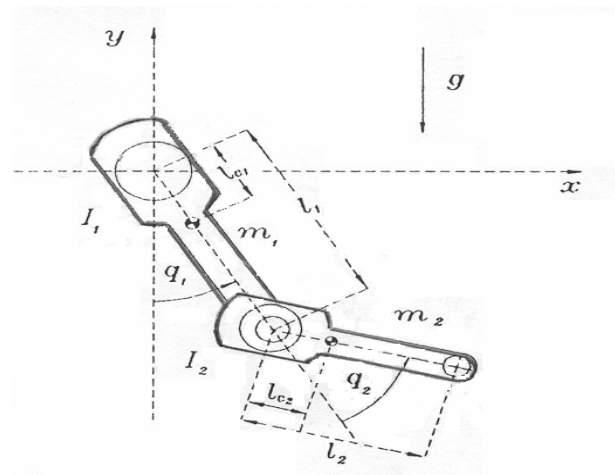
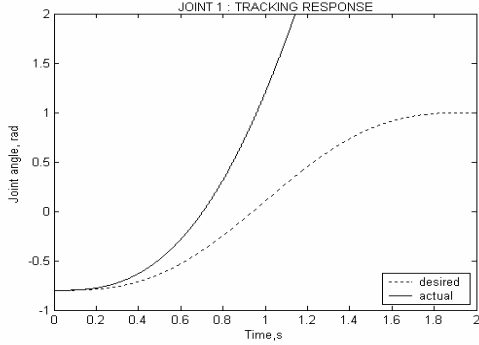
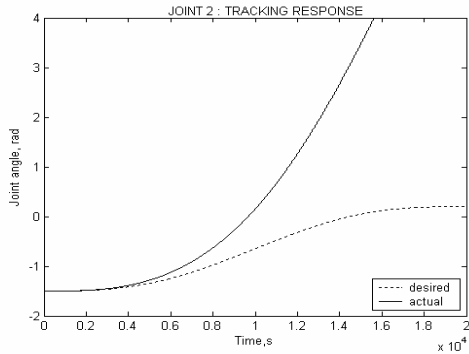

Figure 2: A configuration of 2 DOF Direct Drive Robot Arm



(a) State $x_1(t)$ response for Set 1



(b) State $x_4(t)$ response for Set 1

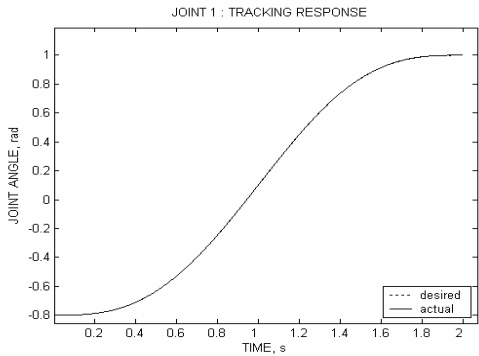

(c) State $x_1(t)$ response for Set 2

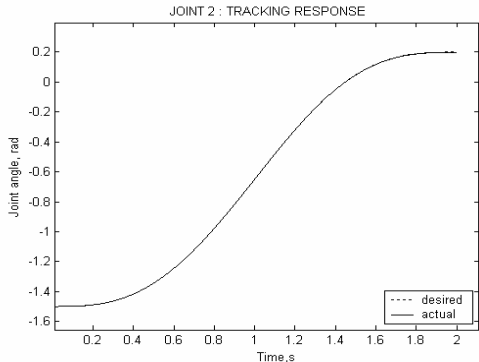

(d) State $x_3(t)$ response for Set 2

Figure 3: Simulation Results for Decentralized PI Sliding Mode Control.

Appendix

Elements of the matrices A and Bhgh

a31 =

$$1.07/((-0.03-0.02\cos(x_4))(0.1+0.08\cos(x_4))+1.96+0.06\cos(x_4))(-0.07(38.47\sin(x_1)+1.82\sin(x_1+x_4))/x_1-0.35(38.47\cos(x_1)-3.65\sin(x_1)\sin(x_4)+3.65\cos(x_1)\cos(x_4))/x_1+(-0.04-0.03\cos(x_4))/((-0.03-0.02\cos(x_4))(0.1+0.08\cos(x_4))+1.96+0.06\cos(x_4))(-0.28\sin(x_1+x_4)/x_1-0.71(3.65\sin(x_1)\sin(x_4)+3.65\cos(x_1)\cos(x_4))/x_1)$$

a32 =

$$1.07/((-0.03-0.02\cos(x_4))(0.1+0.08\cos(x_4))+1.96+0.06\cos(x_4))(-0.16+0.01\sin(x_4)x_5-0.49/x_2+0.06\cos(x_4)x_5)+(-0.04-0.03\cos(x_4))/((-0.03-0.02\cos(x_4))(0.1+0.08\cos(x_4))+1.96+0.06\cos(x_4))(-0.07\sin(x_4)x_2-0.12\sin(x_4))$$

a33 =

$$1.07/((-0.03-0.02\cos(x_4))(0.1+0.08\cos(x_4))+1.96+0.06\cos(x_4))(-8.39-0.01\cos(x_4)+0.06\sin(x_4)+0.06\sin(x_4)x_5)+(-0.04-0.03\cos(x_4))/((-0.03-0.02\cos(x_4))(0.1+0.08\cos(x_4))+1.96+0.06\cos(x_4))(-0.02-0.01\cos(x_4)+0.06\sin(x_4)x_2)$$

a35 =

$$1.07/((-0.03-0.02\cos(x_4))(0.1+0.08\cos(x_4))+1.96+0.06\cos(x_4))(0.01\sin(x_4)x_5+0.03\cos(x_4)x_5)+(-0.04-0.03\cos(x_4))/((-0.03-0.02\cos(x_4))(0.1+0.08\cos(x_4))+1.96+0.06\cos(x_4))(-0.03-0.27/x_5)$$

a36 =

$$1.07/((-0.03-0.02\cos(x_4))(0.1+0.08\cos(x_4))+1.96+0.06\cos(x_4))(-0.01-0.01\cos(x_4)+0.03\sin(x_4)+0.06\sin(x_4)x_2)-7.99(-0.04-0.03\cos(x_4))/((-0.03-0.02\cos(x_4))(0.1+0.08\cos(x_4))+1.96+0.06\cos(x_4))$$

$$\mathbf{b31} = 1.07/((-0.03-0.02\cos(x_4))(0.1+0.08\cos(x_4))+1.96+0.06\cos(x_4))$$

$$\mathbf{b32} = (-0.04-0.03\cos(x_4))/((-0.03-0.02\cos(x_4))(0.1+0.08\cos(x_4))+1.96+0.06\cos(x_4))$$

a61 =

$$(-0.07-0.06\cos(x_4))/((-0.03-0.02\cos(x_4))(0.1+0.08\cos(x_4))+1.96+0.06\cos(x_4))(-0.07(38.47\sin(x_1)+1.82\sin(x_1+x_4))/x_1-0.35(38.47\cos(x_1)-3.65\sin(x_1)\sin(x_4)+3.65\cos(x_1)\cos(x_4))/x_1-(-1.82-0.06\cos(x_4))/((-0.03-2/95\cos(x_4))(0.1+0.08\cos(x_4))+1.96+0.06\cos(x_4))(-0.28\sin(x_1+x_4)/x_1-0.71(3.65\sin(x_1)\sin(x_4)+3.65\cos(x_1)\cos(x_4))/x_1)$$

a62 =

$$(-0.07-0.06\cos(x_4))/((-0.03-0.02\cos(x_4))(0.1+0.08\cos(x_4))+1.96+0.06\cos(x_4))(-0.16+0.01\sin(x_4)x_5-0.49/x_2+0.06\cos(x_4)x_5)-(-1.82-0.06\cos(x_4))/((-0.03-0.02\cos(x_4))(0.1+0.08\cos(x_4))+1.96+0.06\cos(x_4))(-0.07\sin(x_4)x_2-0.12\sin(x_4))$$

$$\mathbf{a63} = (-0.07-0.06\cos(x_4))/((-0.03-0.02\cos(x_4))(0.1+0.08\cos(x_4))+1.96+0.06\cos(x_4))(-8.39-0.01\cos(x_4)+0.06\sin(x_4)+0.06\sin(x_4)x_5)-(-1.82-28/475\cos(x_4))/((-0.03-0.02\cos(x_4))(0.1+0.08\cos(x_4))+1.96+0.06\cos(x_4))(-0.02-0.01\cos(x_4)+0.06\sin(x_4)x_2)$$

a65 =

$$(-0.07-0.06\cos(x_4))/((-0.03-0.02\cos(x_4))(0.1+0.08\cos(x_4))+1.96+0.06\cos(x_4))(1701/296875\sin(x_4)x_5+14/475\cos(x_4)x_5)-(-1.82-28/475\cos(x_4))/((-0.03-0.02\cos(x_4))(0.1+0.08\cos(x_4))+1.96+0.06\cos(x_4))(-0.03-0.27/x_5)$$

a66 =

$$(-0.07-0.06\cos(x_4))/((-0.03-0.02\cos(x_4))(0.1+0.08\cos(x_4))+1.96+0.06\cos(x_4))(-0.01-0.01\cos(x_4)+0.03\sin(x_4)+0.06\sin(x_4)x_2)+0.14(-1.82-28/475\cos(x_4))/((-0.03-0.02\cos(x_4))(0.1+0.08\cos(x_4))+1.96+0.06\cos(x_4))$$

$$\mathbf{b61} = (-0.07-0.06\cos(x_4))/((-0.03-0.02\cos(x_4))(0.1+0.08\cos(x_4))+1.96+0.06\cos(x_4))$$

$$\mathbf{b62} = \frac{(1.82 + 0.06\cos(x_4)) / ((-0.03 - 0.02\cos(x_4)))}{(0.1 + 0.08\cos(x_4)) + 1.96 + 0.06\cos(x_4)}$$