

## Variable Structure Control of Two-Wheels Inverted Pendulum Mobile Robot

Nawawi S.W<sup>1\*</sup>, Ahmad M.N<sup>1</sup> and Osman J.H.S<sup>1</sup>

<sup>1</sup> Faculty of Electrical Engineering  
Universiti Teknologi Malaysia, 81310 UTM Skudai, Johor, Malaysia  
Tel: +60-7-5535236, E-mail: [sophan@fke.utm.my](mailto:sophan@fke.utm.my)

### Abstract

In this paper the position and posture control for the wheeled inverse pendulum type mobile robot is discussed based on simulation result of two types of controller. The robot in this consideration has two independent driving wheels in same axis, and the gyro type sensor to know the inclination angular velocity of the body and rotary encoders to know wheels rotation. This paper will discuss the control algorithm to make the robot autonomously navigate in two dimensional plane while keeping balance its pole.

### Keywords:

Two-wheels inverted pendulum, sliding mode control, nonlinear controller

### 1. Introduction

Some previous researchers on such a wheeled inverse pendulum type robot have been reported. Wheeled inverse pendulum model have evoked a lot of interest recently [1][2][3] and at least one commercial product (Segway) is available [4]. Such vehicles are of interest because they have a small foot-print and can turn on dime. The kinematic model of the system has been proved to be uncontrollable [3] and therefore balancing of the pendulum is only achieved by considering dynamic effects.

Grasser et al [6] derived a dynamic model using a Newtonian approach and the equation were linearized around an operating point to design a controller. In Solerno et al [3] the dynamic equations were studied, with the pendulum pitch and the rotational angles of the two wheels as the variables of interest. Various controllability properties of the system in terms of the state variables were analyzed using differential-geometric approach. T.Kawamura and K.Yamafuji [5] proposed posture and driving control algorithm of similar vehicle. They assumed that the robot has the tactile sensor to detect posture angle between ground and body. They made a good experiment on balancing but the robot could not move in two dimensional plane because the wheels is driven by single servo motor. O.Matsumoto, S.Kajita and K.Tani [6] presented the estimation and control algorithm of the posture using the adaptive observer. The presented algorithm also did not considered the moving control on the two dimensional plane.

E.Koyanagi et al [7] proposed two dimensional trajectory control algorithm for this type of robot and implemented on the real autonomous self contained robot but the algorithm could only work while the robot moves slowly. Y.Ha and S.Yuta [8] propose the algorithm of trajectory tracking of the wheeled inverse pendulum type mobile robot which can run in relatively high speed in the two dimensional plane.

The focus of this research is to make the wheeled inverse pendulum type robot move smoothly in balancing with proper velocity control. The robot is assumed to have two independent driving wheels in same axis to support and move the robot itself. The gyro sensor is attached to know the inclination angular velocity of the body and rotary encoders to know wheels rotation angle. Based on simulation result which getting from control algorithm of [8], it can be shown that the control algorithm can be improved in terms of robustness by other robust controller. The SMC is used to

$$(M_b r l + M_b l^2 + I_b) \ddot{\phi} + [(M_b + M_w) r^2 + M_b r l + I_w] \ddot{\theta} + \mu_g \dot{\theta} - M_b g \phi = 0$$

compare the simulation result of integral state feedback by [8].

### 2. Dynamic Model

This system is modeled based on wheels axle and its vertical axis. And body motion in one dimensional plane is determined by the inclination and translation motion. The model of the robot is shown in figure 1. where,  $\theta$  and  $\phi$  are the wheels rotation angle and the inclination angle of the body respectively and  $\beta$  be the wheel's relative rotation angle to body ( $\theta - \phi$ ). Lagrange motion equation of this model is given as equation (1) and (2) [8].

\*Corresponding Author. E-mail: [sophan@fke.utm.my](mailto:sophan@fke.utm.my)

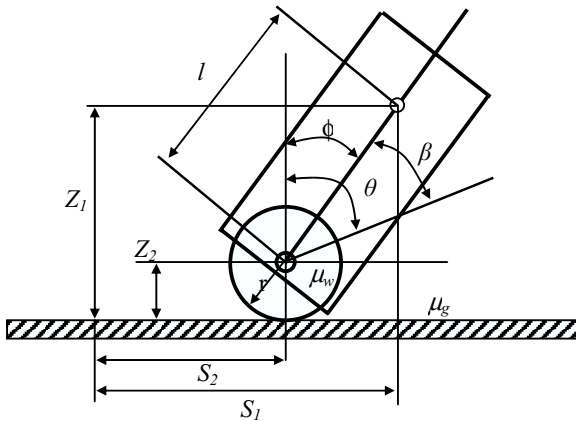

Figure 1: Geometric Parameters and coordinate systems of two wheeled inverted pendulum vehicle

$$\frac{d}{dt} \frac{\partial T}{\partial \dot{\beta}} - \frac{\partial T}{\partial \beta} + \frac{\partial U}{\partial \beta} + \frac{\partial D}{\partial \dot{\beta}} = Q_{\beta} \quad (1)$$

$$\frac{d}{dt} \frac{\partial T}{\partial \dot{\theta}} - \frac{\partial T}{\partial \theta} + \frac{\partial U}{\partial \theta} + \frac{\partial D}{\partial \dot{\theta}} = Q_{\theta} \quad (2)$$

Where:

T=Kinetic energy

U=Potential energy

D=Dissipation energy function

$Q_{\beta}$ =External force to  $\beta$  axis

$Q_{\theta}$ =External force to  $\theta$  axis

$$T = \frac{1}{2} M_w (\dot{s}_2^2 + \dot{z}_2^2) + \frac{1}{2} M_b (\dot{s}_1^2 + \dot{z}_1^2) + \frac{1}{2} I_w \dot{\theta}^2 + \frac{1}{2} I_b (\dot{\theta} - \dot{\beta})^2 + \frac{1}{2} I_M \dot{\beta}^2 \quad (3)$$

$$U = M_w g r + M_b g l \cos(\theta - \beta) \quad (4)$$

$$D = \frac{1}{2} (\mu_w \dot{\beta}^2 + \mu_g \dot{\theta}^2) \quad (5)$$

$$Q_{\beta} = \eta \tau_1 u_1 \quad (6)$$

$$Q_{\theta} = 0 \quad (7)$$

Assume the  $\varphi = 0, \dot{\varphi} = 0$  to linearized in the neighborhood of the up right state.

$$(M_b l^2 + I_b + \eta^2 I_M) \ddot{\varphi} + (M_b r l - \eta^2 I_M) \ddot{\theta} + \mu_w \dot{\varphi} - \mu_w \dot{\theta} - M_b g l \varphi = \eta \tau_1 u_1 \quad (8)$$

$$(M_b r l + M_b l^2 + I_b) \ddot{\varphi} + [(M_b + M_w) r^2 + M_b r l + I_w] \ddot{\theta} + \mu_g \dot{\theta} - M_b g l \varphi = 0 \quad (9)$$

The parameters and variable in equation (8) and (9) is define in Table 1[8].

Value	Parameter and variable name
$M_b = 9.011 \text{kg}$	Mass of the body
$M_w = 6.51 \text{kg}$	Mass of wheel
$I_b = 0.228 \text{kgm}^2$	Rotational inertia of the body
$I_w = 5.1 \times 10^{-4} \text{kgm}^2$	Rotational inertia of the wheel
$I_M = 3.2 \times 10^{-5} \text{kgm}^2$	Rotational inertia of motor axis
$R = 0.062 \text{m}$	Radius of the wheel
$l = 0.138 \text{m}$	Length between the axle of the wheel and gravitational center of the robot body
$\mu_w = 0.0057 \text{Nm/(rad/s)}$	Viscous between the wheel axle including motor and gear
$\mu_g = 0.00425 \text{Nm/(rad/s)}$	Viscous between the wheel and the ground
$\tau_1 = 0.0235 \text{Nm/A}$	Torque constant of the motor
$\eta = 39.5$	Reduction ratio of gear

Table 1: Parameter and variable

The state equation of the linearized model is obtained as (10) from (8) and (9).

$$\dot{x} = Ax + Bu \quad (10)$$

Where:

$$A = \begin{bmatrix} 0 & 1 & 0 & 0 \\ a_1 & a_3 & a_5 & 0 \\ a_2 & a_4 & a_6 & b_2 \end{bmatrix}, B = \begin{bmatrix} b_1 \\ b_2 \end{bmatrix}, x = [\varphi \quad \dot{\varphi} \quad \theta \quad \dot{\theta}]^T$$

$$\begin{matrix} a_1 & a_2 \\ a_3 & a_4 \\ a_5 & a_6 \end{matrix} = \begin{matrix} \frac{(a_{22} \ a_{12}) M_b g l}{\Delta} & \frac{(a_{11} \ a_{21}) M_b g l}{\Delta} \\ \frac{\Delta}{\mu_w a_{22}} & \frac{\Delta}{\mu_w a_{21}} \\ \frac{\mu_w a_{22} + \mu_g a_{12}}{\Delta} & \frac{\mu_w a_{21} + \mu_g a_{11}}{\Delta} \end{matrix}$$

$$\begin{matrix} b_1 \\ b_2 \end{matrix} = \frac{\begin{matrix} a_{22} \eta \tau_1 \\ \Delta \\ a_{21} \eta \tau_1 \\ \Delta \end{matrix}}{\Delta}, \Delta = (a_{11} a_{22} - a_{12} a_{21})$$

$$\begin{matrix} a_{11} & a_{12} \\ a_{21} & a_{22} \end{matrix} = \begin{matrix} M_b l^2 + I_b + \eta^2 I_M & M_b r l - \eta^2 I_M \\ M_b r l + M_b l^2 + I_b & (M_b + M_w) r^2 + M_b r l + I_w \end{matrix}$$

### 3. Controller Design

In order to synthesize the Sliding mode controller we write the state variable as  $x = [\varphi \quad \dot{\varphi} \quad \theta \quad \dot{\theta}]$  and get the following state-space matrices[9]:

$$A = \begin{bmatrix} 0 & 1 & 0 & 0 \\ a_1 & a_3 & a_5 \\ a_2 & a_4 & a_6 \end{bmatrix}, B = \begin{bmatrix} b_1 \\ b_2 \end{bmatrix}, x = [\varphi \ \dot{\varphi} \ \dot{\theta}]^T$$

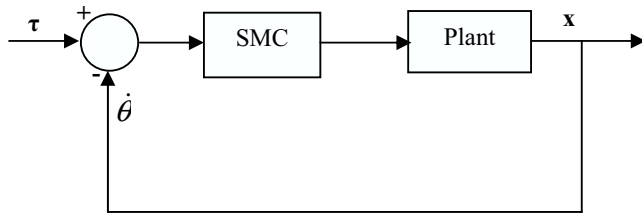

Figure 2: Block diagram of SMC for self-contained mobile inverse pendulum

To develop a sliding mode controller, equation (10) has been decompose as:

$$\begin{bmatrix} \dot{x}_1 \\ \dot{x}_2 \end{bmatrix} = \begin{bmatrix} A_{11} & A_{12} \\ A_{21} & A_{22} \end{bmatrix} \begin{bmatrix} x_1 \\ x_2 \end{bmatrix} + \begin{bmatrix} B_1 \\ B_2 \end{bmatrix} u \quad (11)$$

$$\begin{aligned} x_1 &= \varphi \\ x_2 &= \dot{\theta} \end{aligned}$$

let the switching surface be defined as  $\sigma = Sx$  where

$$\sigma = \begin{bmatrix} S_1 & S_2 \end{bmatrix} \begin{bmatrix} x_1 \\ x_2 \end{bmatrix}, S_1 \in R^{1 \times 3}; S_2 \in R \quad (12)$$

assume the system dynamics is an ideal sliding surface,  $\sigma = Sx = 0$ . Using this property it can be determine the equivalent system and associated linear control input. To proceed, using  $\sigma = 0$

$$x_2 = \frac{S_1}{S_2} x_1 \quad (13)$$

Substitute (13) into (11) yields the equivalent system:

$$\dot{x} = \begin{bmatrix} A_{11} & A_{12} S_2^{-1} S_1 \end{bmatrix} x_1 \quad (14)$$

defining  $k = S_2^{-1} S_1$ :

$$\dot{x}_1 = \begin{bmatrix} A_{11} & A_{12} k \end{bmatrix} x_1 \quad (15)$$

the location of poles of the resulting system are obtained by selecting k and  $S_2$  as the switching function becomes  $\sigma = Sx, S = \begin{bmatrix} S_1 & S_2 \end{bmatrix} = \begin{bmatrix} S_2 k & S_2 \end{bmatrix} = S_2 \begin{bmatrix} k & 1 \end{bmatrix}$ . Pole placement method is use to select the gain k.

The sliding mode control inputs are separated into the linear and nonlinear component as  $u_{eq} = u_l + u_{nl}$ . The linear input  $u_l$  can be selected by the following equations:

$$\dot{\sigma} = S\dot{x} = 0 \quad (16)$$

from (16) and (10), the equivalent linear control input is:

$$u_l = (SB)^{-1} SAx \quad (17)$$

the sliding-mode reaching condition given by  $\sigma\dot{\sigma} < 0$ , bring the system dynamics to the sliding surface  $\sigma=0$ . Choose the nonlinear control  $u_{nl} = (SB)^{-1} \rho \text{sgn}(\sigma)$  where  $\rho > 0$ . Then:

$$\begin{aligned} \sigma\dot{\sigma} &= \sigma S(Ax + Bu) \\ &= \sigma SAx - \sigma SB \left[ (SB)^{-1} SAx + (SB)^{-1} \rho \text{sgn}(\sigma) \right] \\ &= -\rho \sigma \text{sgn}(\sigma) \end{aligned} \quad (18)$$

that is  $\sigma\dot{\sigma} < 0$  whenever  $\sigma \neq 0$ , which means the reaching condition is satisfied. The control input can then be written as:

$$u_{eq} = (SB)^{-1} [SAx + \rho \text{sgn}(\sigma)] \quad (19)$$

### 3. Stability Analysis

For a given control system stability is usually the most important attribute to be determine. The stability of this system with SMC is proved to be stable at the designed sliding surface using lyapunov method. The concept is introduced by Russian mathematician A.M Lyapunov. The lyapunov's method of stability analysis is in principle the most general method for determination of stability of nonlinear or time varying systems.

Lyapunov's Theorem:

1.  $V(t)$  is continuous first partial derivatives
2.  $V(t)$  is positive definite
3.  $\dot{V}(t)$  is locally negative definite

from Ricati equation :

$$Q = PA + A^T P \quad (20)$$

where matrix Q and P is positive definite.

For linear system time-invariant systems, i.e  $f(x,t)=Ax$  a suitable Lyapunov function is  $V(x) = x^T P x$  where P is obtain from Ricati equation and Q is a positive definite symmetric real matrix. The control proposed by M.J Corless and G.Lietmann[10] is  $u_2 = p(x,t)$  where p is any continuous function which satisfies:

$$p(x,t) = \begin{cases} \frac{B^T P x}{\|B^T P x\|} \rho(x,t) \Rightarrow \|B^T P x\| \rho(x,t) > \varepsilon \\ \frac{B^T P x}{\varepsilon} \rho(x,t)^2 \Rightarrow \|B^T P x\| \rho(x,t) < \varepsilon \end{cases} \quad (21)$$

The proposed control action is in fact a continuous approximation of the discontinuous min-max control. For simplicity the case of n-order single input linear time invariant system without uncertain elements is considered. The model of a linear system can be written as follows:

$$\dot{x} = Ax + Bu$$

The switching hyperplane were define as follow

$$\Sigma = \{x | \sigma(x) = 0 \text{ where } \sigma = Sx \text{ and } S \in \mathbb{R}^{1 \times n} \quad (22)$$

to provide the sliding mode, all the phase trajectories in the vicinity of  $\Sigma$  must be oriented toward it[11]. There exists a Lyapunov function  $V(x, t, \sigma)$  such that and in neighborhood of  $\Sigma$ , the condition  $V(x, t, \sigma) = 0$   $V < 0$  is satisfied. In what follows, the switching surface is assume to be chosen so that the restriction of the nominal system to the surface is asymptotically stable. For the single input case a suitable Lyapunov function is:

$$V(x, t) = \frac{1}{2} \sigma^2(x) \quad (23)$$

Thus if  $\dot{\sigma} = S\dot{x} = SAx + SBu$   $\dot{V} = \sigma\dot{\sigma} < 0$  in a neighborhood of  $\Sigma$  for all the time, then all state trajectories initially in this neighborhood, converge to the surface and are restricted to the surface for all subsequent time.

(24)

Assume  $SB \neq 0$  and since the hyperplane  $\Sigma$  does not change if S is multiplied by an arbitrary constant, without loss of generality, it can be assume that  $SB < 0$ . Thus to ensure sliding mode behavior, u can be a any function fulfilling the inequalities:

$$\begin{aligned} u < (SB)^{-1} S(Ax) \Rightarrow \sigma < 0 \\ u > (SB)^{-1} S(Ax) \Rightarrow \sigma > 0 \end{aligned} \quad (25)$$

Now since in sliding mode, the state does not leave the reduced order subspace  $\Sigma$ , the state velocity also belongs to  $\Sigma$ , that is,  $S\dot{x} = 0$ . By the substitution of  $\dot{x}$  from (3) the following is obtained:

$$SAx + SBu_{eq} = 0 \quad (26)$$

Since  $SB \neq 0$ ,  $u_{eq}$  is determined uniquely as:

$$u_{eq} = (SB)^{-1} S(Ax) \quad (27)$$

The sliding mode equation in  $\Sigma$  is:

$$\begin{aligned} \dot{x} &= [I \quad B(SB)^{-1} S] Ax \\ Sx &= 0 \end{aligned} \quad (28)$$

So for SMC controller:

$$V(t) = x^T P x \quad (29)$$

The Lyapunov function  $V(t)$  is positive definite since P is positive definite. The derivative of the Lyapunov function with respect to time t can be obtained as follows:

$$\dot{V}(t) = 2x^T P \dot{x} \quad (30)$$

At sliding surface:

$$\dot{x} = Ax + Bu_{eq}$$

$$u_{eq} = (SB)^{-1} SAx$$

substitute into  $\dot{x}$

$$\dot{x} = Ax + B((SB)^{-1} SAx)$$

$$\dot{x} = (I \quad B(SB)^{-1} S) Ax$$

$$\text{let } \bar{A} = (I \quad B(SB)^{-1} S) A$$

$$\dot{V}(t) = 2x^T P \dot{x}$$

$$\dot{V}(t) = 2x^T P \bar{A} x$$

$$\dot{V}(t) = x^T [P\bar{A} + \bar{A}^T P],$$

substitute Riccati Equation into  $\dot{V}(t)$

$$\dot{V}(t) = -x^T Q x$$

From Rayleigh's principle:

$$\lambda_{\min}(Q) \|x\|^2 \leq x^T Q x \leq \lambda_{\max}(Q) \|x\|^2$$

$$\therefore \dot{V}(t) = -x^T Q x \leq -\lambda_{\min}(Q) \|x\|^2$$

The derivative of the Lyapunov is always negative, which prove via Lyapunov stability theorem that this system equilibrium state at the origin is asymptotically stable. In SMC beside proving the stability at sliding condition, another important thing to prove is the stability of the reaching condition. So for the reaching condition:

$$u_{eq} = (SB)^{-1} [SAx + \rho \operatorname{sgn}(\sigma)]$$

$$u_{eq} = (SB)^{-1} SAx + E$$

where:  $E = \rho \operatorname{sgn}(\sigma)$

now for the case of multi input system, assume:

$$\|E\| = \hat{\rho}(x, t)$$

let

$$u^* = (SB)^{-1} SAx + \frac{B^T S^T \sigma}{\|B^T S^T \sigma\|} \rho(x, t) \Rightarrow \|\sigma\| > 0$$

$$(SB)^{-1} SAx \Rightarrow \|\sigma\| = 0$$

And  $\rho(x,t) = \alpha + \hat{\rho}(x,t)$ ,  $\alpha > 0$ . For such  $u^*$  the derivative  $\dot{V}$  becomes:

$$\dot{V}(t) = \sigma^T \dot{\sigma} = \sigma^T \left[ SAx + SB \left( -(SB)^{-1} SAx - \frac{B^T S^T \sigma}{\|B^T S^T \sigma\|} \rho(x,t) \right) + SBE \right] \leq -\alpha \|B^T S^T \sigma\|$$

It can be seen that the implementation of  $u^*$  assures that the derivative of Lyapunov function is negative everywhere outside the switching surface. From the above derivation it can be shown that the SMC designed for the inverse pendulum mobile robot plant is proved to be asymptotically stable.

### 3. Simulation Result

For the propose controller of SMC, the simulation result can be seen much better then SFIC which propose by Yuta S. [8] in term of time response and percent of overshoot. The sliding surface which using in SMC for the propose controller is  $S=[12; 4.6; 1]$ . The value of S is tune by heuristic.

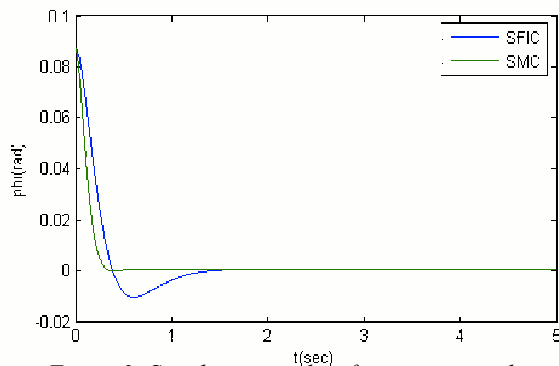

Figure 3: Simulation results of posture control using State Feedback Integral Control (SFIC) and SMC

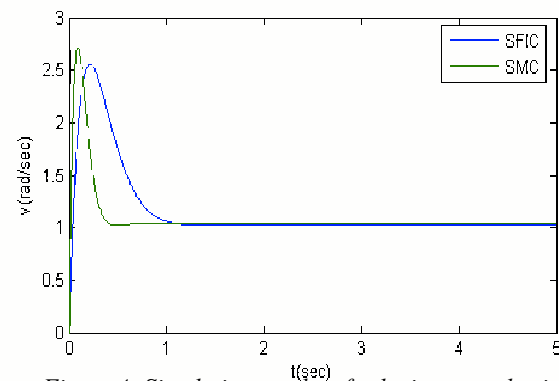

Figure 4: Simulation results of velocity control using State Feedback Integral Control (SFIC) and SMC

### 4. Conclusion

In this paper a two-wheeled inverted pendulum type robot is discussed. It has the advantage of mobility from without caster and an innate clumsy motion for balancing. The proposed controller in particular SMC shows the good control behavior of the system to be control. It can be seen in the result of the simulation. The characteristics of the SMC appear to be more robust and good control compare to SFIC on inverse pendulum type mobile robot.

### References

1. Grasser F., D'Arrigo, A., Colombi, S. and Rufer, A. "Joe; A Mobile Inverted Pendulum", IEEE Trans. Industrial Electronics, vol.49, no 1, pp. 107, no 114, 2002
2. Baloh, M and Parent, M., "modeling and model verification of an intelligent self balancing two-wheeled vehicle for an autonomous urban transportation system". Conf. Comp. Intelligence, Robotics and autonomous systems, Singapore, Dec, 15 2003.
3. Salerno A and Angeles J " On the nonlinear controllability of a quasiholonomic mobile robot", Proc, IEEE ICRA Taiwan 2003.
4. "Segway Human Transporter", <http://www.segway.com> 2003.
5. Yamafuji K. and Kawamura T., "Postural control of monoaxial bicycle", Journal of the robotic society of japan, vol.7 No 4 pp 74-79, 1988
6. Matsumoto O., Kajita S. and Tani K., "Attitude estimation of the wheeled inverted pendulum using adaptive observer", Proc. Of 9<sup>th</sup> Academic Conf of robotic Society of Japan, pp.909-910, 1991
7. Koyanagi K., Iida S., Kimoto K. and Yuta S., "A wheeled inverse pendulum type self-contained mobile robot and its two dimensional trajectory control" Proc of ICMCR 92, pp.891-898, 1992.
8. Ha, Y.S and Yuta S., "Trajectory tracking control for navigation of the inverse pendulum type self-contained mobile robot", Robotics and autonomous systems, 17, pp. 65-80, 1996.
9. Lee J.H., Allaire P.E., Tao G. and Zhang X., "Integral Sliding mode control of a Magnetically Suspended Balance beam: analysis, simulation and experiment", IEEE/ASME Trans. On mechatronics Vol 6 no 3, September 2001.