

**VOT 71586**

**DESIGN AND CONSTRUCTION OF A NEW COAXIAL HIGH  
VOLTAGE FAST IMPULSE CURRENT TRANSDUCER**

*(REKABENTUK DAN PEMBINAAN TRANSDUSER ARUS  
DEDENYUT VOLTAN SEPAKSI )*

**ZULKURNAIN B. ABDUL MALEK**

**RESEARCH VOTE NO:  
71586**

**Institut Voltan & Arus Tinggi  
Fakulti Kejuruteraan Elektrik  
Universiti Teknologi Malaysia**

**2003**

## **Acknowledgement**

*The author would like to acknowledge and thank The Research & Management Centre, Universiti Teknologi Malaysia for providing the grant for this research.*

## **Abstract**

Since the introduction of zinc-oxide material in 1968 much research has been directed towards the characterisation of the electrical behaviour of the material under various stress conditions. An aim of some of these investigations is to achieve an equivalent circuit representation, which adequately simulates the observed test results. An adequate equivalent circuit representation will aid the reliable and efficient design of the overvoltage protection and help to improve the optimisation of the protective devices. A significant impediment to the accurate characterisation of zinc oxide has been the lack of reliable test data especially for fast-rate-of-rise impulses in the microsecond and sub-microsecond range. The measurement of current impulses in this range is highly influenced by the circuit arrangement and measurement transducer characteristics. In this work, a non-inductive coaxial current shunt was designed and constructed. The fast impulse tubular current shunt was based on the nickel chromium resistive material with a designed value of  $5\text{m}\Omega$  and  $10\text{kA}$  current capability. The current shunt was successfully constructed except the nickel chromium material, which could not be successfully soldered to the aluminium casings. It is recommended that the work is to be completed in future projects.

## Abstrak

Sejak 1968 iaitu apabila bahan zink oksida mula digunakan, banyak penyelidikan telah dilaksanakan dan ianya tertumpu kepada pencirian elektrik bahan tersebut dalam pelbagai keadaan tegasan. Salah satu tujuan utama kajian yang dilaksanakan ialah untuk mendapatkan perwakilan litar setara zink oksida. Perwakilan litar setara yang sesuai dapat membantu dalam penghasilan rekabentuk perlindungan voltan lampau yang mempunyai keboleharapan dan kecekapan yang tinggi dan juga membantu penggunaan peralatan perlindungan secara optimum. Satu penghalang penting untuk pencirian zink oksida secara tepat ialah kurangnya data ujikaji berkeboleharapan tinggi terutamanya untuk dedenyut yang mempunyai kadar menaik yang pantas dan dalam julat sub-mikrosaat hingga mikrosaat. Pengukuran dedenyut arus dalam julat ini sangat dipengaruhi oleh susunatur litar dan ciri-ciri transduser. Dalam kajian ini, satu perintang pirau sepaksi tanpa berinduktan telah direkabentuk dan dibina. Perintang pirau yang direkabentuk telah berjaya dibina kecuali bahan nikel-kromium yang tidak dapat dipateri kepada perkakasan aluminium. Aktiviti ini dicadangkan dilaksanakan pada projek seterusnya.

## CONTENTS

<b>TOPICS</b>	<b>PAGE</b>
Acknowledgement	ii
Abstract	iii
Abstrak	iv
Contents	v
List of Tables	vii
List of Figures	viii
List of Symbols	x

### **CHAPTER 1            INTRODUCTION**

1.1	Introduction	1
1.2	Objectives	2
1.3	Scope of Project	2
1.4	Direction of Project	2
1.5	Expected Results/Benefits	3

### **CHAPTER 2            MEASUREMENT OF HIGH IMPULSE CURRENT**

2.1	Introduction	4
2.2	The Resistive Method	5
2.2.1	Squirrel Cage Shunts	7
2.2.2	Coaxial Shunts	9
2.2.3	Tubular Shunt	10
2.3	The Inductive Method	10
2.3.1	Rogowski Coils	11
2.4	Optical Method (Faraday Ammeter)	12

**CHAPTER 3            TUBULAR SHUNT DESIGN**

3.1	Introduction	15
3.2	Tubular Shunts Design Procedure	16
3.3	Calculation for Nickel Chromium Dimension	19
3.4	Alternative Resistive Material	24

**CHAPTER 4            COAXIAL CURRENT SHUNT CONSTRUCTION**

4.1	Materials Used In Constructing the Shunt Resistor	27
4.1.1	Aluminium	27
4.1.2	Nylon	28
4.1.3	Acrylic	29
4.2	Technical Drawing of Coaxial Shunt Resistor	30
4.3	Construction	32

**CHAPTER 5            CONCLUSION AND SUGGESTIONS**

5.1	Conclusions	44
5.2	Suggestions	45

<b>REFERENCES</b>	<b>46</b>
-------------------	-----------

**LIST OF TABLES**

<b>TABLE NO.</b>	<b>TOPIC</b>	<b>PAGE</b>
Table 3. 1	: Nickel Chromium properties.	20
Table 3.2	: Resistive materials property.	25
Table 3.3	: Calculated dimension of resistive materials required to give 5 m $\Omega$ value of resistance.	26

**LIST OF FIGURES**

<b>FIGURE NO.</b>	<b>TOPIC</b>	<b>PAGE</b>
2. 1	Equivalent circuit of low-ohmic resistor by neglecting the skin effect.	5
2.2	Bifilar design of low ohmic resistor. (a) folded resistive sheet material. (b) bifilar wound individual resistor	7
2.3	Simplified equivalent circuit of coaxial squirrel cage shunt.	8
2.4	Rogowski coil with integrator for impulse current measurements.	12
2.5	Measurement of impulse current by magneto-optic	14
3.1	Tubular shunt	16
3.2	Impulse current waveform.	20
3.3	Squared impulse current waveform	20
4.1	Overall view of shunt resistor	33
4.2	Upper Shielding 1	33
4.3	Upper Shielding 2	34
4.4	Upper Shielding 3	34
4.5	Perspex Ring 1	35



4.6	Perspex Ring 2	35
4.7	Input Terminal 1	36
4.8	Input Terminal 2	36
4.9	Input Terminal 3	37
4.10	Ni/Cr Cylinder 1	37
4.11	Ni/Cr Cylinder 2	38
4.12	Nylon Cylinder	38
4.13	Nylon Ring	39
4.14	Nylon Cylinder	39
4.15	Aluminium Cylinder 1	40
4.16	Aluminium Cylinder 2	40
4.17	Earth Terminal 1	41
4.18	Earth Terminal 2	41
4.19	Lower Terminal	42
4.20	Earth Base 1	42
4.21	Earth Base 2	43

**LIST OF SYMBOLS**

DC,dc	-	Direct current
Ac,ac	-	Alternating current
c	-	Specific heat
Hz	-	Hertz
R	-	Resistance
ZnO	-	Zinc Oxide
D	-	Density
t	-	Time
$\rho$	-	Resistivity
$\gamma$	-	Thermal coefficient
mm	-	Millimeter
m	-	Meter

## CHAPTER 1

### INTRODUCTION

#### 1.1 Introduction

Measurement of current in high voltage circuits is routinely required whether in power transmission systems or in high voltage testing laboratories. It is often necessary to determine the amplitude and waveform of rapidly varying high currents. Routine tests of high voltage equipment are normally simple so that the measuring equipment required is not very complex. However, the measurement devices required for a research laboratory is often more complex because the accuracy and bandwidth required are much greater. High impulse currents can be produced in a lightning discharge. The current amplitude may range from a few amperes to few hundred kiloamperes. The rate of rise for such current can be as high as  $10^6$  to  $10^{12}$  A/s while the rise time can vary from a few microseconds down to a few nanoseconds. Such shunt resistors are usually custom made for specific uses. The main purpose in this project is to design and construct a shunt resistor for fast impulse current measurements.

The working principle of a resistive shunt is quite simple. The voltage measured across the shunt is directly proportional to the measured current. All of the materials required for the construction of the current shunt should be locally available.

## 1.2 Objectives

The main objective of this project is to design and develop a locally made tubular shunt resistor. This resistor will be used to measure high current impulses with maximum amplitude of 10 kA and the rise time is 1 $\mu$ s.

The resistance of this shunt resistor is chosen to be 5 m $\Omega$  so that the output voltage is about 50 volts. This rated voltage is therefore small enough to be measured directly by a cathode ray oscilloscope. The shunt should also be able to withstand the amount of corresponding heat generated during high current discharges.

## 1.3 Scope

The chosen resistive material for the current shunt was Nickel Chromium. The outer casing of this shunt was made from aluminum while a perspex plate was used to isolate the inner cylinder and outer cylinder from each other. The design of the current shunt eliminates the inductive effects commonly found in typical wire wound resistor. By this way, the proportionality of voltage measured to the current can be trusted.

#### **1.4 Direction of the Project**

The direction of the present work is to design better techniques for measuring non-inductive impulse current for ZnO surge arresters. So, in this project, the characteristic of impulse current, ZnO surge arresters, current shunt principles and lastly, a newly designed coaxial current shunt will be extensively explored.

#### **1.5 Expected Results**

A new current transducer system suitable for fast transient response measurements complete with signal capturing facilities is expected to be produced. This transducer will be incorporated in the 100 kV low inductance test module for zinc oxide fast transient studies. Ultimately, a new set of zinc oxide characterisation based on the test results obtained using the test module will be achieved.

## CHAPTER 2

### MEASUREMENT OF HIGH IMPULSE CURRENT

#### 2.1 Introduction

In high voltage technology, there is often a need to ascertain the peak value and the waveform of high, rapidly changing currents, as in discharging energy storage capacitor banks in plasma physics, transient phenomena in power system and lightning research. Experiments are often carried out where the amplitude of the applied impulse current may vary from ten to millions of amperes, with rise times usually in the microsecond range. To record these fast events, wide-band measurement devices with the system response times of the same order are necessary.

In this chapter, existing measuring techniques are surveyed and the basic theory described. The measurement of high amplitude fast rate of rise currents has been achieved by using three core principles namely, the resistive, the inductive and the optical method.

## 2.2 The Resistive Method

The most common method of measuring the waveform of high impulse currents is by measuring the voltage drop across the resistor in series with the circuit under test. The current is obtained from the quotient of the voltage dropped across the resistance divided by the resistance value itself. This can be shown as in Figure 2.1. If the resistor has purely real ohmic resistance, its voltage drop is proportional to the current. The resistor applied must be of a low ohmic value in order that the output voltage measured across it does not exceed the rated value of measuring devices.

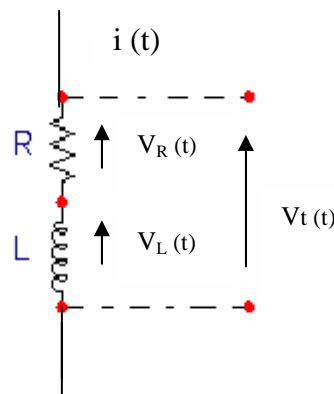

**Figure 2. 1 Equivalent circuit of low-ohmic resistor by neglecting the skin effect.**

Currents flowing through ohmic resistors cause surrounding magnetic and electric fields. In a simple equivalent circuit, the stray fields are modeled by a series inductor and resistor with this combination shunted by a capacitor. For comparatively high ohmic resistors used to measure high ac voltages, the inductance may often be neglected. This is because the reactance  $\omega L$  reaches the order of  $R$  only at very high frequencies as  $\omega = 2\pi f$ . If the impulse rate of rise is sufficiently high in the inductive component, the voltage measured across the resistor can significantly affect the measured result, as shown in the following equation.

$$V = iR + L \frac{di}{dt} \quad (2.1)$$

In order to reduce the inductive effects, coaxial designs of shunt resistance must be considered. Many types of current shunt have been designed in order to reduce the effect of the magnetic coupling, namely coaxial shunt, squirrel shunt, tubular shunt and disc shunt. Various types of shunt designs that adopt a coaxial arrangement for shunt resistance have been applied widely. Resistors suitable in measuring high, rapidly changing currents usually have resistance values between 0.1 and some 100mΩ. Such low values are required to limit heat dissipation and loading effects on the circuit under test. A series-current measuring device obviously has no loading effect if its terminal impedance is small compared with the remaining impedance.

Stray inductance must be kept as small as possible to minimize the inductive voltage that appears with a high  $di/dt$  and that may be many times greater than the resistive component. This is usually achieved by appropriate design and suitable choice of geometrical dimensions. Two older designs of bifilar constructed resistor which have low inductance are shown in Figure 2.2. The design consists of a folded resistive sheet material with both ends insulated by Teflon or asbestos and voltage pickup at a coaxial UHF connector. The resistor also consists of several bifilar wound individual resistors in parallel to reduce the residual inductance of the arrangement.



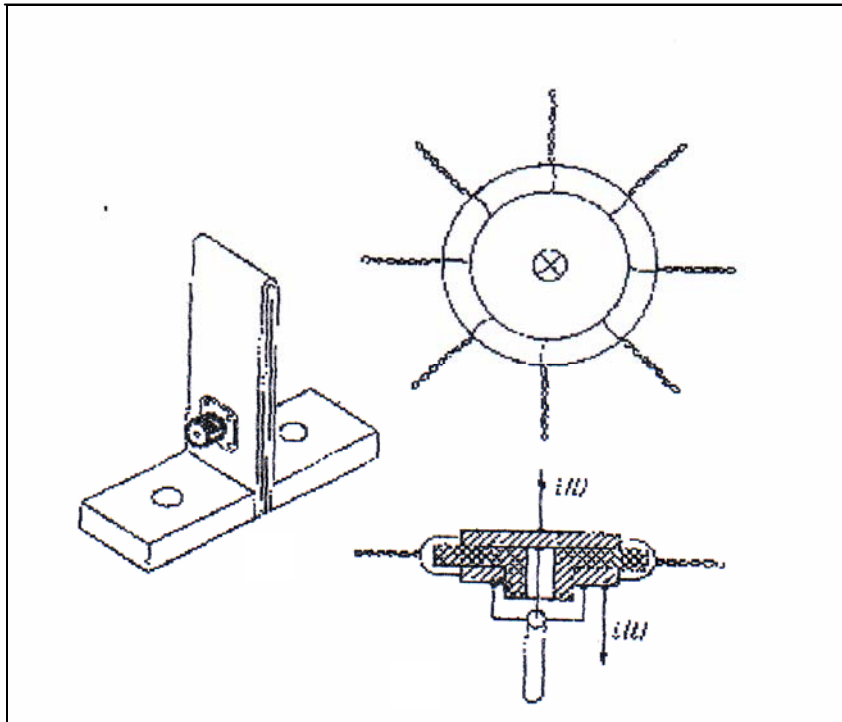

**Figure 2.2: Bifilar design of low ohmic resistor.**

All bifilar construction however suffers from stray inductance associated with the resistor element and its potential leads surrounding a small part of the magnetic flux linked with the current that is measured. In order to overcome this problem, coaxial construction has been chosen.

### 2.2.1 Squirrel Cage Shunts

Some special applications such as post arc-current measurement require shunts that can absorb the energy of large surges. So, these shunts must have large cross sections and wall thickness, they exhibit excessive skin effect even at comparatively low frequency.

To compensate the skin effect, various experimenters have placed gaps in the resistance cylinder or fabricated the shunt from several rods which resulted in the squirrel cage shunt configuration. Since the gaps allow the magnetic flux to penetrate into the original field-free space of the inner cylinder, it was expected that the insufficient voltage drops produced by skin effect would be compensated by the peak induced by the potential loop. Unfortunately this is not effective because penetration of the outer field may be represented in a simplified manner by addition of a further inductance  $L_{ms}$  as shown in Figure 2.3.

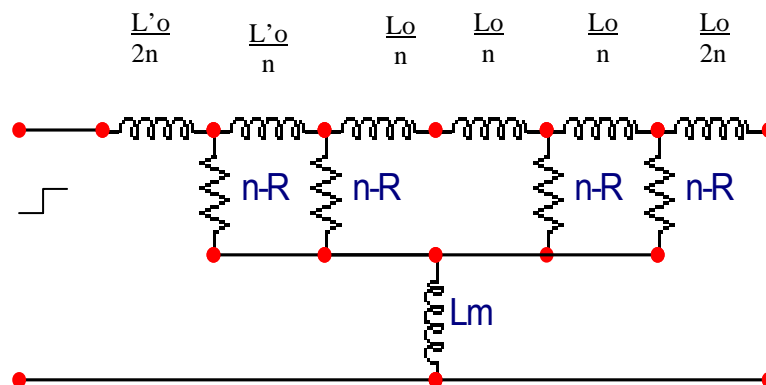

**Figure 2.3 Simplified equivalent circuit of coaxial squirrel cage shunt.**

Calculation of the inner inductances  $L_o/n$  and the inductance  $L_m$  is significantly more complex than that of the simple tubular shunt. However, skin effect may be represented by a transmission line model consisting of five lumped sections, as in the case of tubular shunts. Because of the disadvantage, high quality shunts should normally be of the tubular type. The squirrel-cage form may however exhibit good high frequency performance if a passive electronic compensation network equalizes its frequency response.

### **2.2.2 Coaxial Shunts**

A coaxial construction has the advantage that the current flowing in the shunt does not produce any electromagnetic fields outside the gap between the tubes. In a design described by E.Thornton, by designing the shunt in double coaxial form, the effects of transit time can be eliminated. Another advantage of this type of coaxial shunt is that there is no distortion of the pulse being measured since the coax line is undisturbed, and it has been used at 70kV potential. In general, the output from any coaxial shunt is obtained by measuring the voltage between a pair of distinct points of the resistive tubes. The route of the sense wires, as well as the location of their end points will influence the output voltage. It is possible to compensate for the skin effect by routing the sense wire through the wall of the inner resistive element. By choosing an appropriate trajectory for the wire, it is possible to induce voltages in the measuring circuit that produce an improved transient response. Alternatively, a second sense wire can be routed from the top of the shunt so that it forms a loop in the air gap enclosing the magnetic field. Both techniques can result in a greatly improved transient performance.

Usually, because of their physical size, such designs are limited to low current amplitude pulses. The principles may however be adopted for the measurement of current impulses in a coaxial system for current amplitude up to the 100kA range.

### **2.3 Tubular Current Shunts**

A tubular current shunt basically comprises a hollow cylinder of thin nonmagnetic resistive material. The material placed coaxially around the potential lead. This arrangement ensures that the potential lead is in a field-

free environment. Beside that, it must be unaffected by electromagnetic coupling effects.

The basic working principle of this tubular shunt is that the current enters the device through the resistive cylinder and returns to earth through an outer nonmagnetic cylinder enclosing the shunt assembly. In addition to providing a current return path to earth, the outer cylinder functions to shield the resistive material from stray external fields.

### 2.3 The Inductive Method

When a conductor carries an electric current, a magnetic field will establish around that conductor. Based on the Ampere's Law, the induced magnetic field  $H$  is given by

$$I = \int H \cdot dl \quad (2.2)$$

If a single turn coil of this conductor is placed perpendicular to a magnetic field such that the flux  $\Phi$  links the coil, an emf,  $e$  will be generated according to the Faraday's Law, that is

$$e = - d\Phi/dt \quad (2.3)$$

The amount of emf generated depends on the size of the coil. The current magnitude and its rate of change can be related to the magnetic flux and the rate of change of the flux. There are three types of measurement device which are commonly used based on the inductive method. They are Rogowski coils, linear coils and pulse current transformers. The Rogowski coil method is described in the next section.

### 2.3.1 Rogowski Coils

Rogowski coil current transducers have been used for measuring and detecting electric current for decades. They have normally been considered only when other methods are unsuitable (used as a last resort). Rogowski coils are also used to measure insulation discharges.

A Rogowski coil is a current measurement device which obtain its output from a portion of the magnetic flux surrounding the current carrying conductor about which it has been placed. As such it requires no physical contact with the circuit element under observation.

The coil is constructed from a toroidal winding placed round the conductor being measured. It is essentially comprised of B-dot probes wound in series in the form of helix around a toroid core which is typically of circular, square or rectangular cross-section. Linkage between the primary and the secondary conductor is by the magnetic flux.

In order to eliminate the effect of undesirable field from interfering with the secondary winding, the Rogowski coil assembly is encased in a similarly shaped non-magnetic metallic casing (usually aluminium). The coil is effectively a mutual inductor coupled to the conductor being measured where the output from the winding is an emf proportional to the rate of change of current. The coils are designed to give a high degree of rejection of interference from external magnetic fields.

Since the output from the coil is proportional to the rate of change of current, it has to be integrated electronically. The voltage output from the integrator reproduces the original current waveform and can be monitored using any appropriate equipment such as a multimeter, oscilloscope, transient recorder or protection relay. Figure 2.4 show an example the Rogowski coil set-up used for current measurement.

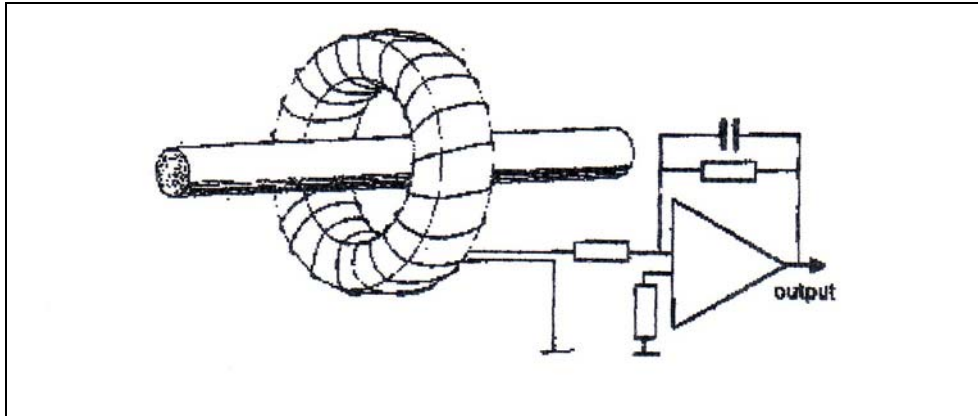

**Figure 2.4 Rogowski coil with integrator for impulse current measurements.**

For a given coil the sensitivity can be adjusted over an enormous range by selecting appropriate values for the integrator components. The same flexible coil can be used to measure current ranging from a few milliamperes to several megamperes. The sensitivity in unit volts/amp is equivalent to a resistance and can be thought of as an 'equivalent shunt resistance'.

Unlike a resistor, a Rogowski coil provides galvanic isolation and produces no heating. Beside that, it does not require insertion into the circuit nor any other potential connection between the measuring circuit and the current path. The probe is usually fully isolated from the circuit and its location can be arbitrarily chosen. This merit is counterbalanced by the inability to sense dc component, a limitation of no serious importance in most pulse applications.

## 2.4 Optical Method (Faraday Ammeter)

The optical method is based on the principle that a linearly polarized light beam passing through a transparent crystal in the presence of a

magnetic field undergoes a rotation of its plane of polarization. The angle  $\alpha$  of rotation is a function of the magneto-optic rotary power of the crystal  $V$ , the crystal length  $l$ , and the magnetic flux density  $B$

$$\alpha = V \cdot B \cdot l \quad (2.4)$$

The symbol  $V$  represents Verdet constant and depends upon the wavelength  $\lambda$ . A polarization detector usually determines the angle of rotation. The arrangement shown in Figure 2.5 is usually used to measure the waveform of large current. An incandescent bulb driven by a stabilized voltage generates collimated light beam that is polarized by polarizer  $P_1$ . The polarized light beam passes the crystal  $F$  parallel to the field lines of the unknown magnetic field, thereby undergoing a rotation of its plane of polarization. Having passed through Polarizer  $P_{11}$  the beam hit the cathode of a photomultiplier. A cathode-ray oscilloscope records the output voltage of the photomultiplier. The beam path contains an optical filter that permits only monochromatic light to pass to the photomultiplier.

The advantage of this device as compared with low-ohmic resistors is the absence of any electrical connection which results in a less interference. It also does not face any thermal problem during steady-state load conditions of several kiloamperes.

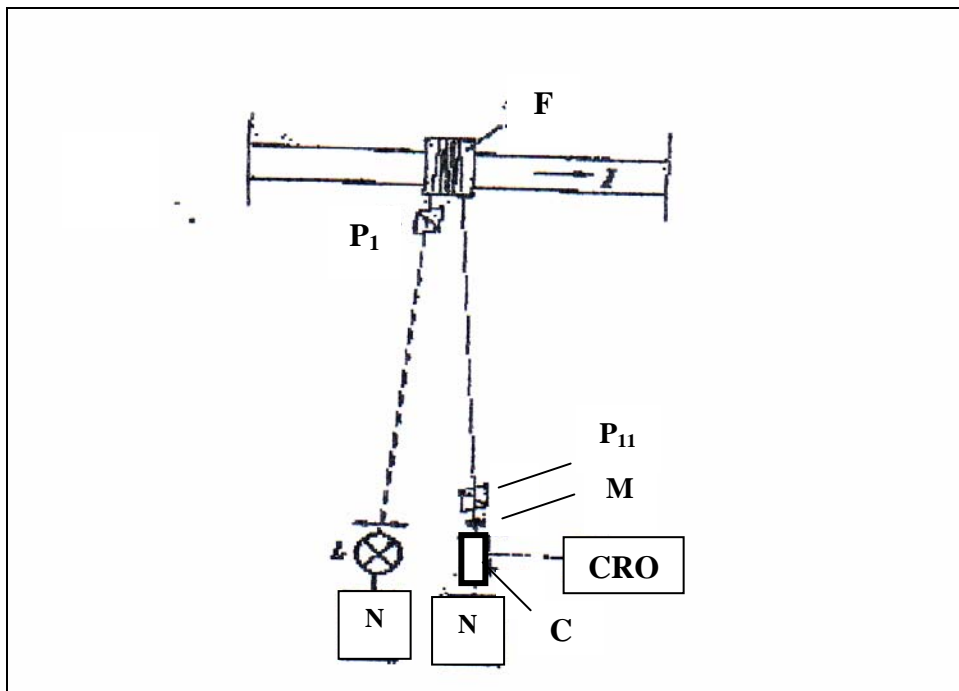

Figure 2.5: Measurement of impulse current by magneto-optic



## CHAPTER 3

### TUBULAR SHUNT DESIGN

#### 3.1 Introduction

The measurement of impulse current can be carried out by a calibrated low-ohmic resistor in series with the circuit under test. We have discussed earlier that if the resistor has a purely ohmic resistance, its voltage drop is proportional to the current. But for low-ohmic resistor used to measure high currents, it is difficult to satisfy the above assumption. The time domain voltage drop is affected by non-ideal properties of the measuring resistor, as represented by self and mutual inductances as well as the skin effect.

Currents flowing through ohmic resistor may cause surrounding magnetic and electric fields. These stray fields can be modeled by an inductance placed in series with the resistor. The tubular shunt resistance has already been decided to be as low as possible. So we need to limit the inductance value to be less or equal to zero. This can be achieved by appropriate design and suitable choice of geometrical dimensions.

### 3.2 Tubular Shunt Design Procedure

Tubular current shunt resistor operation can be described as follow (see Figure 3.1). The tubular current shunt is connected in series with the circuit under test. The impulse current generated enters the resistor at the current input terminal (1). The current flow through the inner cylinder (2) made of non-magnetic material foil. The resistive foil is soldered at both ends namely the input terminal and the earth terminal (5). The voltage drop across the inner cylinder is measured by using potential lead (4) placed between the input terminal and the outer case of the coaxial shunt which is connected to the earth terminal. The potential lead is extended to the cathode ray oscilloscope for signal reading. The space between potential lead and the inner cylinder is free from any electric and magnetic fields. So this design resistor should act as a pure ohmic resistor. The current returns through outer cylinder (3) made from conducting material that encloses the shunt and provide the current path to ground.

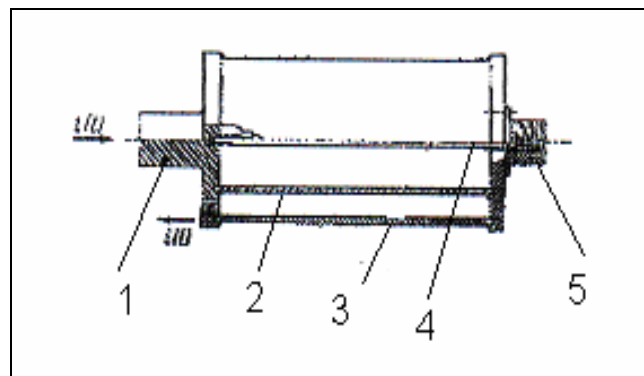

**Figure 3.1: Tubular Shunt**

The impulse rating of low-ohmic resistors depends solely upon the thermal capacity of the resistive element. Since the standard impulse current is of short duration, it is possible to assume that no heat is being transferred

to the surrounding. At the same time the impulse current is heating the resistive material. This means that the electrical energy is converted into thermal energy and stored in the resistive material. This can be shown in mathematical equation as,

$$\int R i^2 dt = m c \Delta T \quad (3.1)$$

where  $m$  = specific weight in  $\text{g/cm}^3$

$c$  = specific heat of the resistive material in  $\text{Cal/g}^\circ\text{C}$

$\Delta T$  = the temperature rise in  $^\circ\text{C}$

According to the above equation the impulse rating is related to the weight of the resistive material. The above equation when divided by the resistance value yields the limit load integral  $\int i^2 dt$ , which is often used as a specification for the thermal impulse rating of current shunts.

The main purpose in designing the shunt resistor is to determine the prospective peak current amplitude to be measured, ( $I_{\max}$ ) and the limit of the recording equipment ( $V_{\max}$ ). After the two parameters have been determined, the resistive value can be calculated based on the following equation,

$$V_{\max} = R_{\text{sh}} \cdot I_{\max} \quad (3.2)$$

The next step to be considered is to determine the maximum acceptable relative change in resistance of resistive material. This value should be as low as possible so that the resistance change at high

temperature is slightly lower. The value should be selected such that the relative change in resistance is within 0.1%.

When the relative change in resistance had been determined, the maximum allowable temperature rise can be calculated. By knowing this, it can be used to determine the volume of the resistive material required to construct the resistive shunt that has adequate thermal capacity. The material must be capable to withstand the conversion from electrical to thermal energy. The maximum allowable temperature can be calculated by using the following equation,

$$\Delta R_{sh} = \gamma \Delta T \quad (3.3)$$

where  $\Delta R_{sh}$  = the maximum relative change in resistance

$\gamma$  = the temperature coefficient of the material

$\Delta T$  = the maximum acceptable relative change in temperature

When the maximum relative change in resistance and the maximum acceptable relative change in temperature have been determined, the resistance of resistive material can be calculated using

$$\Delta R_{sh} = \frac{(R_{sh} \theta - R_{sh})}{R_{sh}} \quad (3.4)$$

where  $R_{sh}\theta$  = the resistance at the maximum acceptable temperature.

The volume of the resistive material,  $V$  can be determined based on Equation 3.5

$$V = \frac{m}{\delta} \quad (3.5)$$

where  $\delta$  = the density of the material. Then the physical dimensions of the shunt can be determined as

$$V = d w l = A l \quad (3.6)$$

where

- $d$  = the thickness of the material,
- $w$  = the width of the material,
- $l$  = the length of the material, and
- $A$  = the cross-sectional area of the material

Table 3.1 shows the properties of the chosen resistive material namely nickel chromium.

**Table 3. 1: Nickel Chromium properties.**

Definition	Symbol	Value
Density	$\delta$	8.4 g/cm <sup>3</sup>
Resistivity	$\rho$	108 $\mu\Omega$ .cm
Thermal coefficient	$\gamma$	0.00005 C <sup>-1</sup>
Specific heat	c	0. 107 cal/ g°C
Max. relative change in R <sub>sh</sub>	$\Delta R_{sh}$	0.1%
Max. permissible relative temperature rise	$\Delta T$	20 °C

### 3.3 Calculation for Nickel Chromium Dimension

The first step to be taken is to determine the impulse current waveform flowing through the shunt resistor. An example of the impulse current waveform is shown in Figure 3. 2.

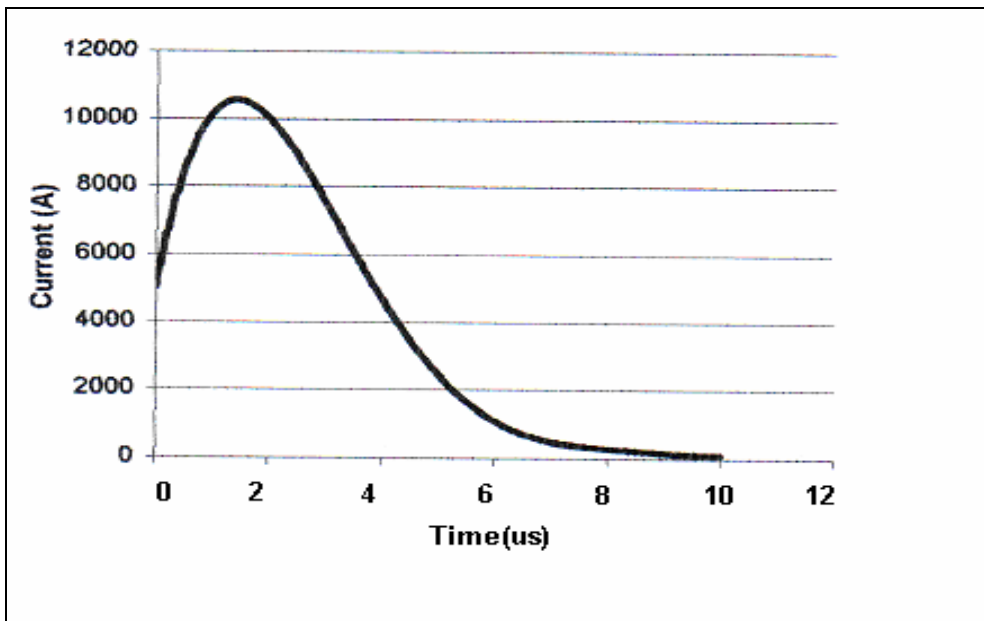

Figure 3.2 Impulse current waveform (1/4 shape)

Referring to equation 3.1,  $\int i^2 dt$  represent the area below the squared current waveform. The corresponding squared waveform current is shown in Figure 3.3.

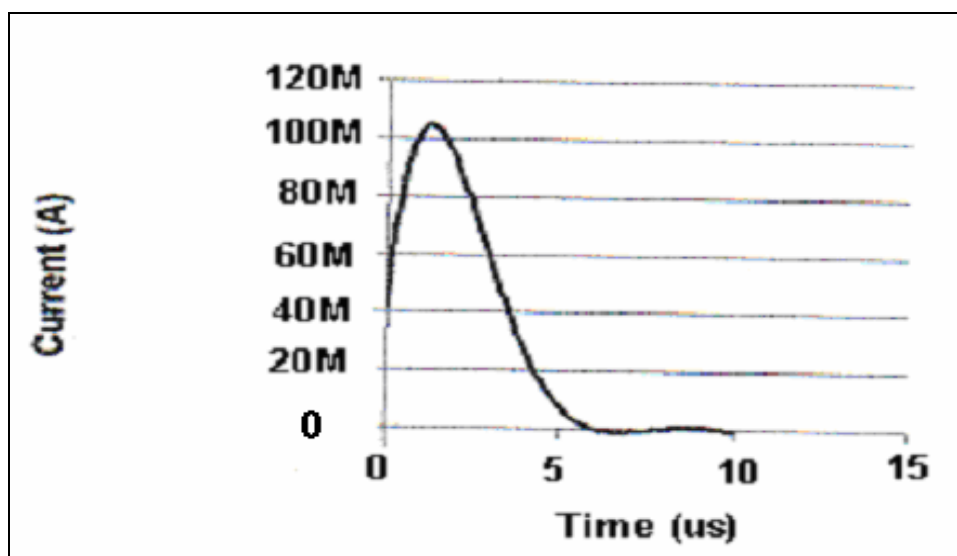

Figure 3.3: Squared impulse current waveform

To calculate the area below the waveform of Figure 3.3, the 3/8 Simpson Method was applied. The value of the area is 31344.26 A<sup>2</sup>s. Substituting the above value in Equation 3.1, the mass of Nickel Chromium required to form 51mΩ resistance is obtained. The calculation is shown as below.

$$(5\text{m}\Omega) \times (31344.26\mu\text{A}^2\text{s}) = m (0.107 \text{ cal/g}^\circ\text{C}) \times (20^\circ\text{C})$$

$$m = 73.2342\text{g}$$

Now we need to calculate the volume of the shunt resistor. This volume is needed to confirm the dimension of Nickel Chromium required to achieve 5mΩ resistance. By using the equation 3.5, the volume is calculated as

$$V = 8.718363373 \text{ cm}^3$$

We also know that the resistance of a material is given by

$$R_{\text{sh}} = \frac{\rho l}{A} \quad (3.7)$$

While cross sectional area of foil, A can be obtained by

$$A = \sqrt{\frac{\rho V}{R_{\text{sh}}}} \quad (3.8)$$

and

$$l = \sqrt{\frac{V R_{\text{sh}}}{\rho}} \quad (3.9)$$



From equation 3.8, we obtain  $A = 0.433954662 \text{ cm}^2$ . Then, the next calculation using Equation 3.9 gives the required length of the resistive foil which is  $l = 20.09\text{cm}$ .

The relationship between the area and the thickness of the foil is given by

$$A = d \cdot w \quad (3.10)$$

To calculate the foil width, we need to consider the thickness of the Nickel Chromium foil. This is because the thickness of the foil will affect the risetime of the shunt. The risetime of the shunt is given as:

$$T_r = \frac{\mu d^2}{k \rho} \quad (3.11)$$

It can be clearly seen from the above equation that the thickness of the foil should be as thin as possible so that the risetime can be reduced. The coefficient  $k$  being in the region of  $4 < k < 6$ . In this work, the coefficient  $k$  was chosen to be equal to 8. This is because the response time is determined more accurately when the coefficient  $k$  equals to 8 [2].

By reducing the foil thickness, we gain benefit by reducing measurement errors associated with skin effect. The reduction of the thickness of the resistive material is limited due to product availability in the market. Furthermore, the price of the thinner resistive material will cost much higher due to the difficulties in the production process. In this work the thickness of Nickel Chromium foil is chosen as 0.125mm. Therefore, from Equations 3.9 and 3. 10 we obtain the foil width of 34.7172cm.

### **3.4 Alternative Resistive Material**

Consideration of other resistive materials in constructing the shunt resistor was also carried out. One of the important properties is that the shunt material must be non-magnetic. The material must also have high specific heat coefficient to withstand the high temperature rise. The other characteristics such as the density, resistivity and thermal coefficient of the chosen material must be equal or nearly equal to those of the Nickel Chromium.

Initial investigation showed that the properties of the NiCr are largely dominated by the nickel element. Therefore other Nickel based alloys should be studied as alternatives. The main objective in this sub-topic is to evaluate the maximum allowable energy absorption of the various available alternative materials.

Evanohm and Nikrothal L are the most preferable nickel based alloys to be used as alternatives to Nickel Chromium. The resistivity, density and specific heat of these materials are almost equal to those of NiCr. But the Evanohm's temperature coefficient is much lower than that of NiCr. Constantan and Manganese are the least suitable alternatives. This is because their resistivity and specific heat are much lower than Evanohm and Nikrothal L but their density is equal to the density of NiCr. The detailed properties of these alternatives resistive materials are shown in Table 3.2.

**Table 3.2: Resistive materials property.**

Alloy	Nickel Cromium	Nikrothal L	Evanohm	Constantan	Manganese
Thickness (mm)	0.125	0.125	0.125	0.125	0.125
Length (cm)	20.097	18.436	18.779	28.977	31.839
Width (cm)	34.717	39.232	35.453	22.718	21.916
Cylindrical radius (cm)	5.525	6.244	5.643	3.616	3.487

Using the data in Table 3.2 and applying Equations 3.1 to 3.10, the dimension of the resistive material required to give a value of  $5\text{m}\Omega$  in resistance can be calculated. Table 3.3 shows the dimension required for all the resistive materials considered.

**Table 3.3: Calculated dimension of resistive materials required to give 5 mΩ value of resistance.**

Alloy	Nickel Cromium	Nikrothal L	Evanohm	Constantan	Manganese
Thickness (mm)	0.125	0.125	0.125	0.125	0.125
Length (cm)	20.097	18.436	18.779	28.977	31.839
Width (cm)	34.717	39.232	35.453	22.718	21.916
Cylindrical radius (cm)	5.525	6.244	5.643	3.616	3.487

## **CHAPTER 4**

### **COAXIAL CURRENT SHUNT CONSTRUCTION**

#### **4.1 Materials Used in Constructing The Shunt Resistor**

##### **4.1.1 Aluminium**

Aluminium is the abundant metal in the earth's crust and the third most abundant of all elements after oxygen and silicon. Alumina is made up of aluminium and oxygen. To produce aluminium metal, it is necessary to separate these two elements in the Alumina. The process which transforms alumina into aluminium is called smelting.

The aluminium, in a molten form, sinks to the bottom of the pot. It is siphoned out in a process known as tapping and is transported to a holding furnace being cast as pure aluminium (better than 99.7%) or small amounts of other elements such as magnesium, silicon or manganese are added to form aluminium alloys. Different alloys give different properties to the metal, such as extra strength or greater resistance to corrosion.

Primary aluminium can be rolled, extruded or cast to make aluminium end products. Rolling involves a block of aluminium being 'squashed' between large rollers to make product such as aluminium plates, sheets or foils.

Extruding is a process in which round logs (billet) of hot aluminium are forced through a pattern cut into a steel die. Casting occurs when molten aluminium is poured into moulds to manufacture specific shapes. Aluminium is a non-rusty metal type that is commonly used as a replacement of copper. Pure metal aluminium has high tensile characteristic which is about 90Mpa (13 kPsi), good resistivity and has high temperature withstand. Aluminium of 6061 type was used to to build the coaxial shunt component in this work.

#### **4.1.2 Nylon**

Nylon has a high coefficient of thermal expansion (about three times that of Aluminium) and low heat conductivity. The family of nylons consists of several types. Nylon 6/6, nylon 6, nylon 6/10, nylon 6/12, nylon 11, nylon 12, and nylon 6-6/6 copolymer are the most common. Of these, nylon 6/6 and nylon 6 dominate the market. The numbers refer to how many methyl units (-CH<sub>2</sub>-) occur on each side of the nitrogen atoms (amide groups). The difference in number of methyl units influences the property profiles of the various nylons. Moisture absorbance is decreased due to reduced polarity with further separation and less regular location of the very polar amide groups.

Resistance to thermal deformation is lowered due to more flexibility and mobility in these methyl unit sections of the main chain. As these units increase in length, making the molecules appear more like polyethylene, the properties of the nylon shift slightly toward those of polyethylene. Not considering the effects of moisture, Nylon 6/12 has lower modulus, higher elongation, lower strength, lower thermal distortion temperature, lower

hardness and lower melting point than nylon 6/6. Nylon 6/12 is more expensive than nylon 6/6. The property which gives nylon 6/12 its utility is moisture absorption which is approximately half of that of nylon 6/6. This means the properties are much more consistent and experience less fluctuation due to ambient humidity levels in the end application.

Another dominant feature of nylons is crystallinity. As with most crystalline polymers, the molecular chains are uncluttered by large substituent groups. They are flexible and regular in group spacing and crystallize readily. As with acetals, this crystallinity is responsible for properties of wear resistance, chemical resistance, thermal resistance, and unfortunately, higher mold shrinkage. The overall excellent profile of nylons results in their probably having the most diverse range of applications of all thermoplastic polymers.

#### **4.1.3 Acrylic**

Acrylic is a type of plastic product. It only has half the weight of glass. Acrylic has a great impact resistant and also unaffected by sun or salt spray. Temperature range of the acrylic plastic is around -30 to 1600°F for continuous service.

Before this material being process to end product, it needs to be washed with mild soap or detergent, with plenty of lukewarm water, dry with soft cloth or chamois. Grease, oil or tar can be removed with hexane or kerosene. Solvent residue should be removed by washing immediately. Window-cleaning sprays, scouring compounds, acetone, gasoline, benzene, carbon tetrachloride or lacquer thinner should not be used.

When working with the material, the paper masking film needs to be left on the sheet as long as possible. Except for intricate detail work, the masking should only be removed when the project is completed. All tools should be sharp. Water or drilling oil need to be used as a coolant when

cutting sheets over 1/8" thick or drilling sheets over 3/16" thick. The material needs to be wet before cleaning process.

Acrylic sheet up to 3/16" thick may be cut by a method similar to that used to cut glass. A scribing knife, a metal scribe, an awl, or a utility knife can be used to score the sheet. The scribe need to be drawn several times (7 or 8 times for a 3/16" sheet) along a straight edge held firmly in place. Then the sheet needs to be clamped or held rigidly under a straight edge with the scribe mark hanging just over the edge of a table. A sharp downward pressure need to be applied to break the sheet along the scribe line. The edges can be scaped to smooth any sharp comers. This method is not recommended for long breaks or thick material.

Acrylic can be heated to make it pliable. It will become rigid. A strip heater is the best tool to form acrylic. This tool will only form straight. The sheet can be heated until it begins to sag at the bend line. The bend should be made away from the side exposed to the heating element. Sheet thicker than 3/16" should be heated on both sides for a proper bend. For best results forming jigs or clamps should be used, and heavy cotton gloves should be worn when handling heated acrylic.

## **4.2 Technical Drawings of Coaxial Shunt Resistor**

After the dimension of core material (Nickel Chromium foil) is determined, the next step is to design whole structure of the tubular shunt resistor. Application of AutoCAD software plays major part in this section.

Figure 4.1 show the overall view of the shunt resistor designed and constructed. Figures 4.2 to 4.21 show the complete design with all relevant parts of the whole current shunt.



Some consideration must be taken before the designing process of the outer part is started. Detailed information of the standard size and dimension for the materials used must be known first. Availability of these required materials also need to be considered. Aluminium sheet with the thickness of 1 mm was used to build the hollow cylinder for the outer casing part of the shunt resistor (Figure 4.15). Rivet connections were applied to achieve the desired geometry (cylindrical shape). This part should have at least three levels of screw holes for the assembly process of the input terminal, earth terminal and earth base. All of these parts are made from solid Aluminium 6061.

The upper shielding (Figures 4.2 – 4.4) was placed on the top part to enclose the shunt. This part was also made from solid Aluminium 6061. The input terminal (Figure 4.7) and the upper shielding need to be insulated to prevent short circuit of the current path. So the insulator applied is made of perspex (Figure 4.5), which is acrylic clear plate. This material has been chose because of its high temperature withstand characteristic.

Nylon cylinder (Figure 4.14) was placed on the inside of the Nickel Chromuim The nylon cylinder provides support for the foil itself. Inside the nylon cylinder, there is a hollow path to place copper lead used for sending impulse current signal to measuring devices such as cathode ray oscilloscope.

The earth terminal was placed between the input terminal and the earth base. At the center of this part, a BNC connector was placed as a connector for the coaxial cable and the measuring devices. There is a space between the earth terminal and the earth base as a place to connect the coaxial cable from outside the shunt resistor.

### **4.3 Construction**

The Mechanical Production Laboratory, UTM, had been chosen to construct the shunt. However, due to the long delay to get the job done, an outside of the university vendor was engaged. Nickel chromium material was imported from the United Kingdom. However, the material could not be soldered to the aluminium terminals due to the special flux (acid based) required. Until the date of this project report, the flux was not yet able to be purchased.

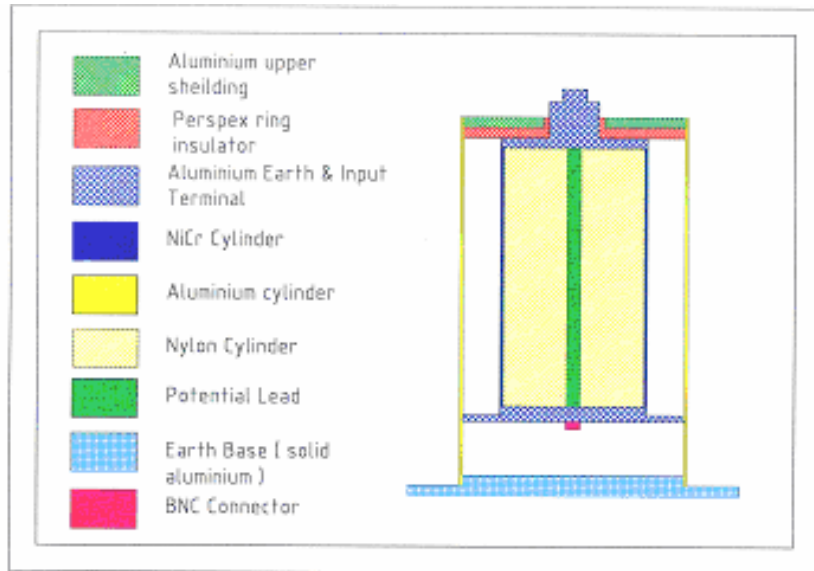

**Figure 4.1 : Overall view of Shunt Resistor**

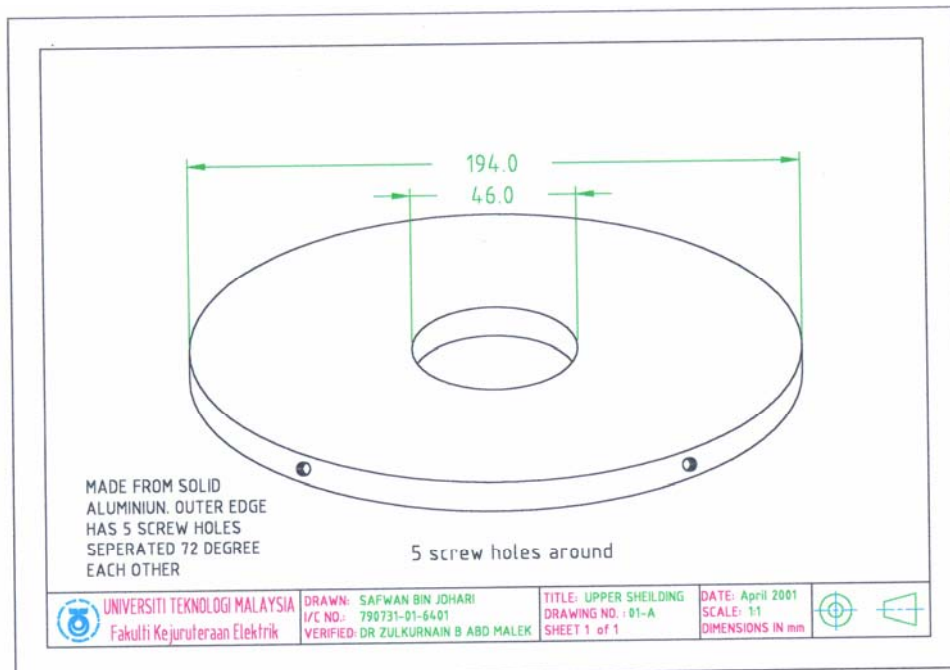

**Figure 4.2 : Upper Shielding 1**

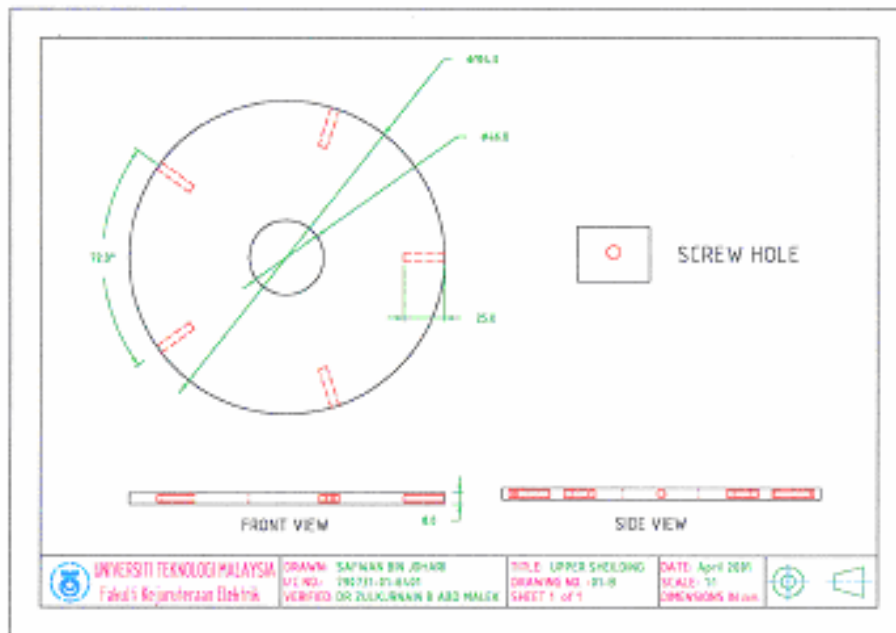

Figure 4.3 : Upper Shielding 2

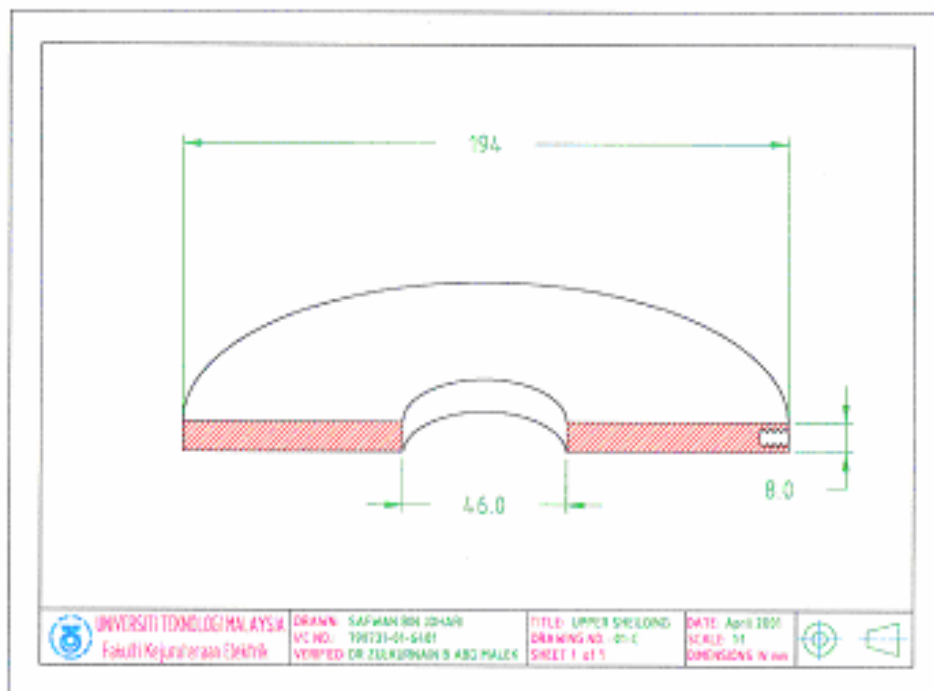

Figure 4.4 : Upper Shielding 3

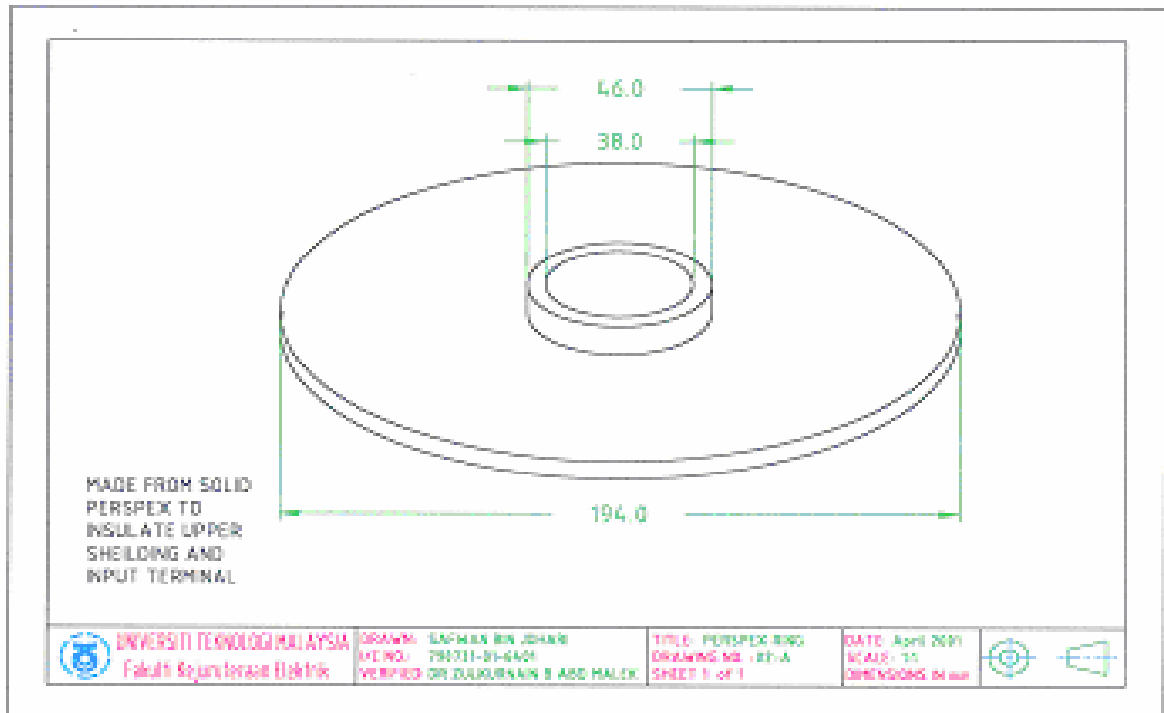

Figure 4.5 : Perspex Ring 1

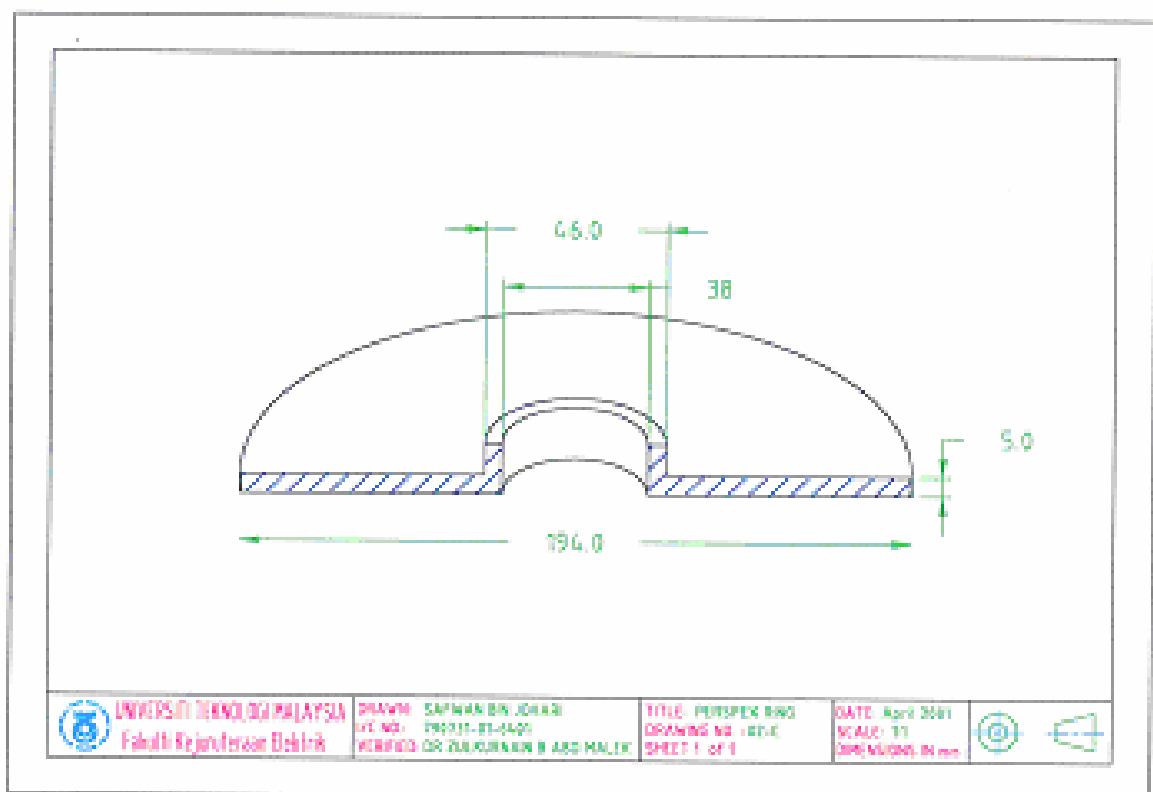

Figure 4.6 Perspex Ring 2

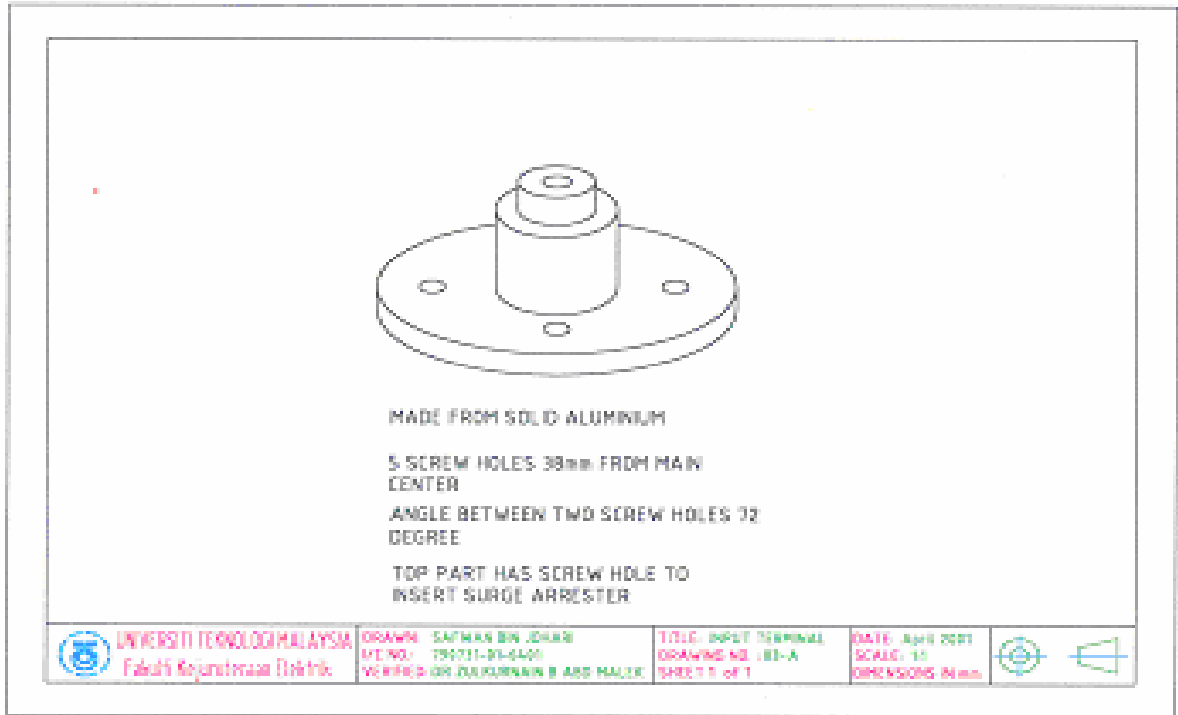

Figure 4.7 Input Terminal

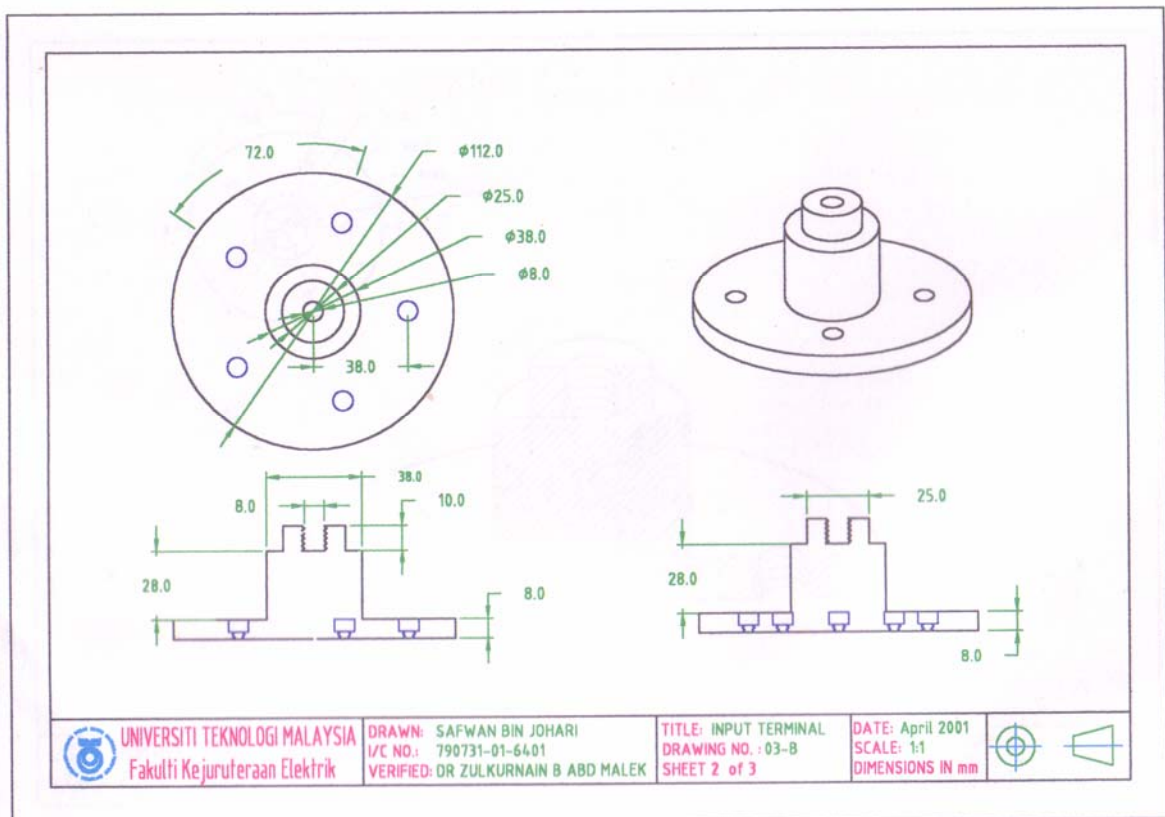

Figure 4.8 Input Terminal 2

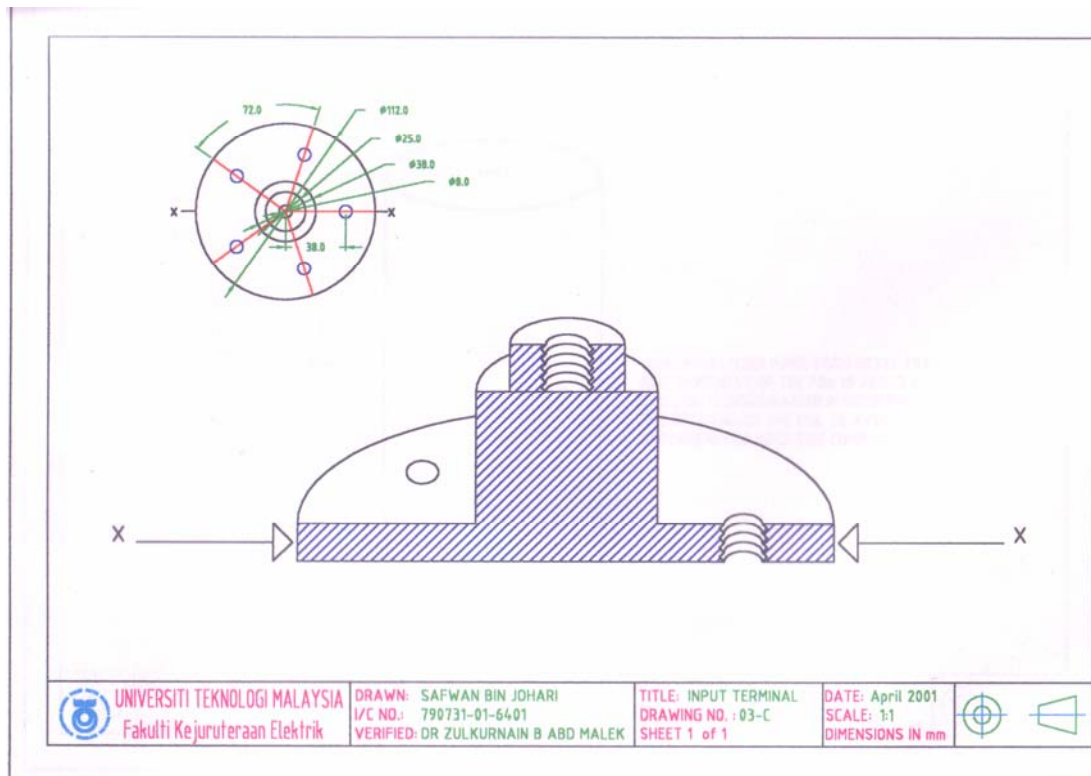

Figure 4.9 Input Terminal 3

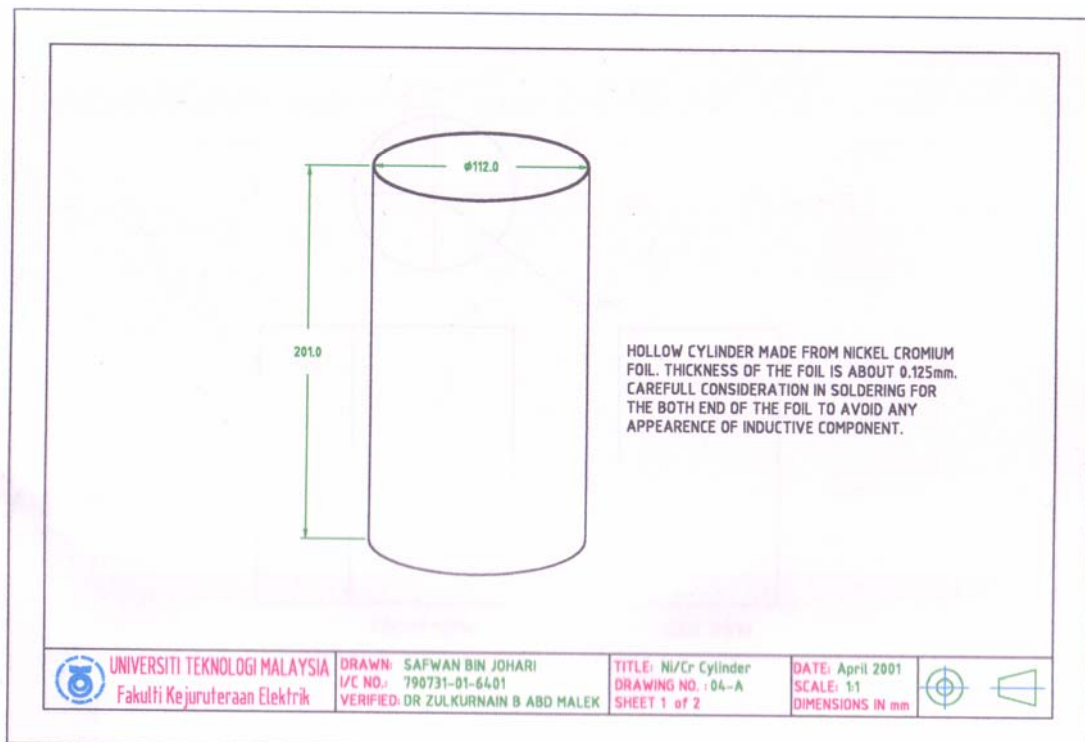

Figure 4.10 Ni/Cr Cylinder

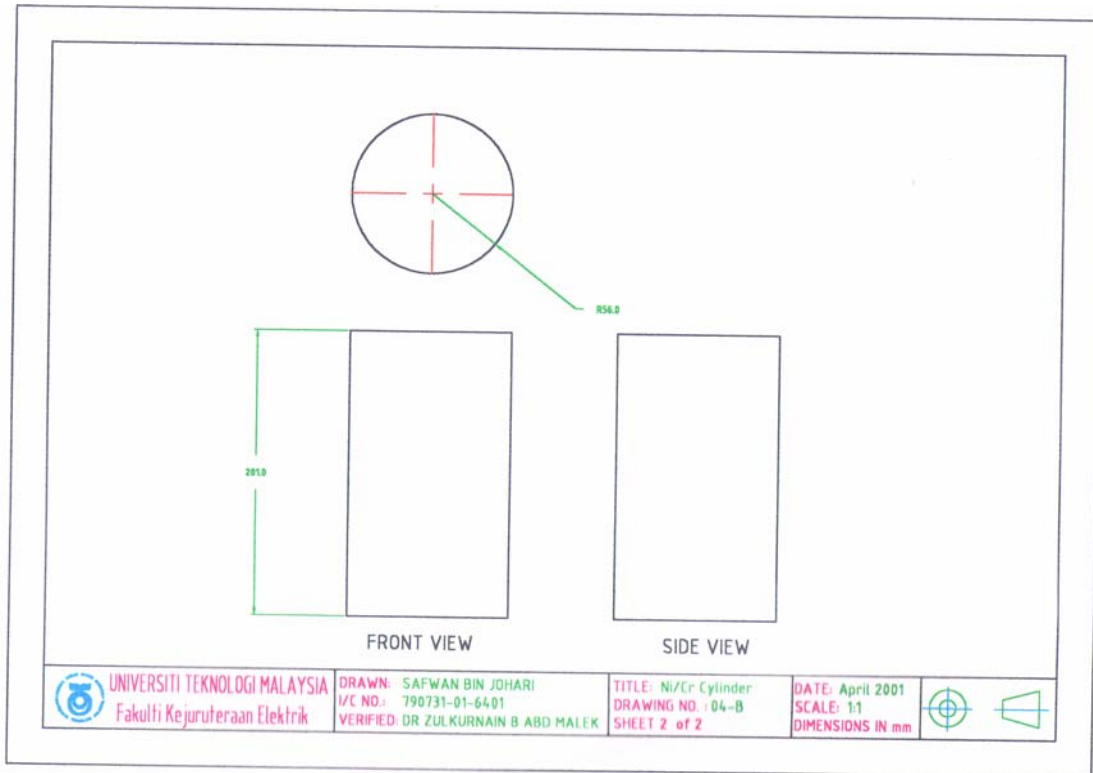

Figure 4.11 Ni/Cr Cylinder 2

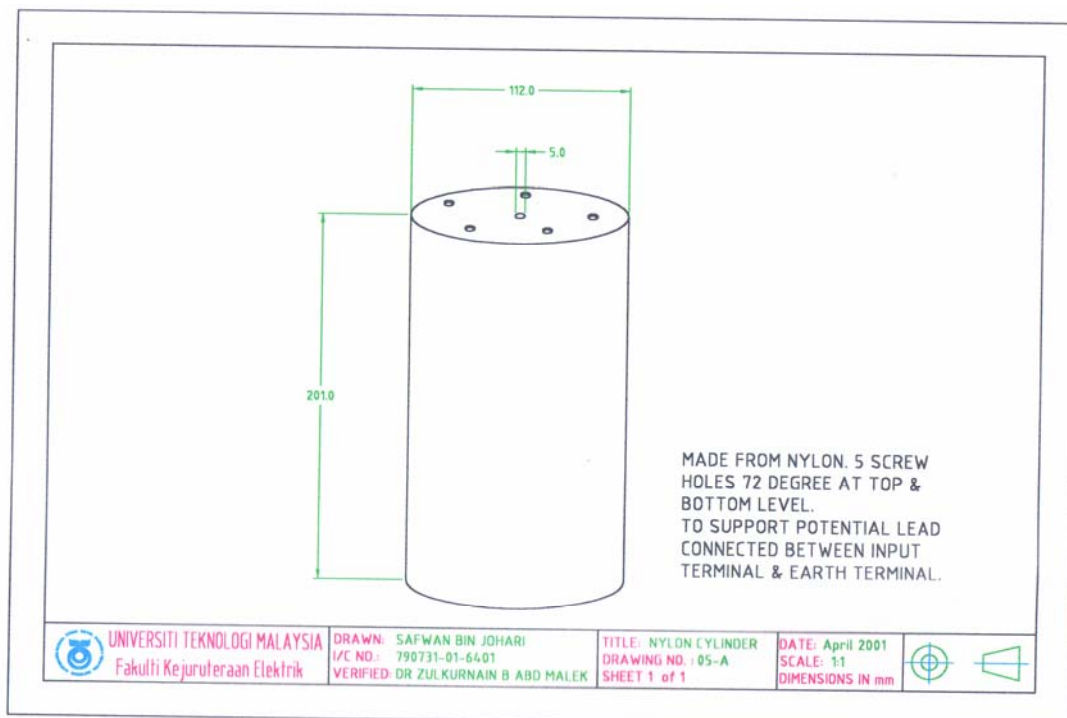

Figure 4.12 Nylon Cylinder



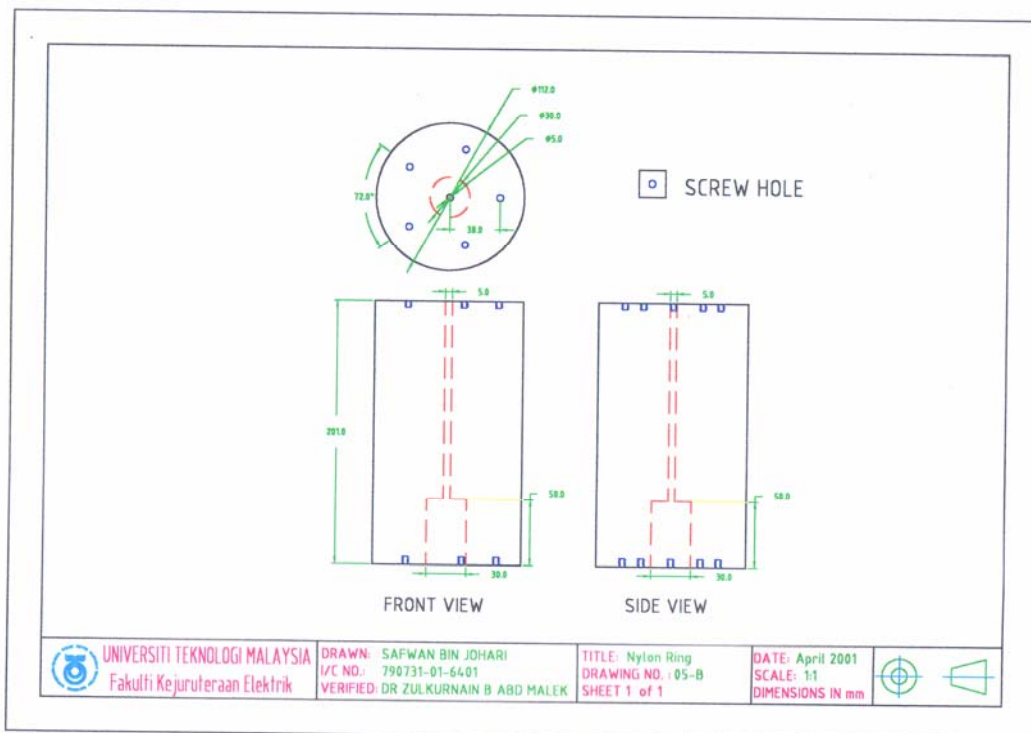

Figure 4.13 Nylon Ring

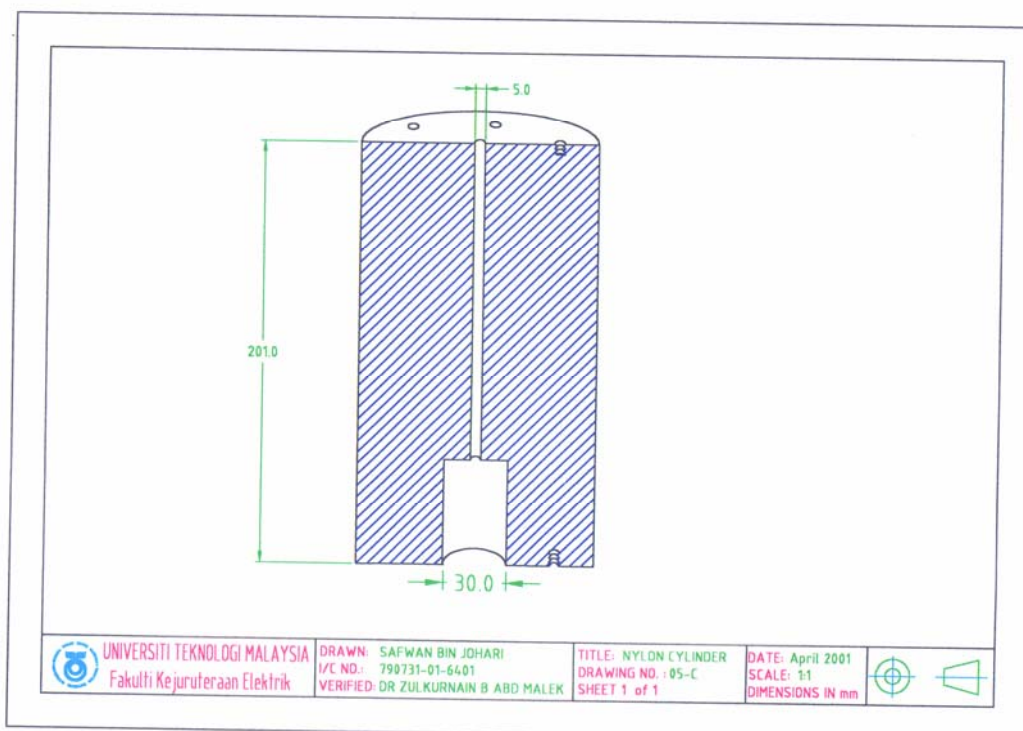

Figure 4.14 Nylon Cylinder

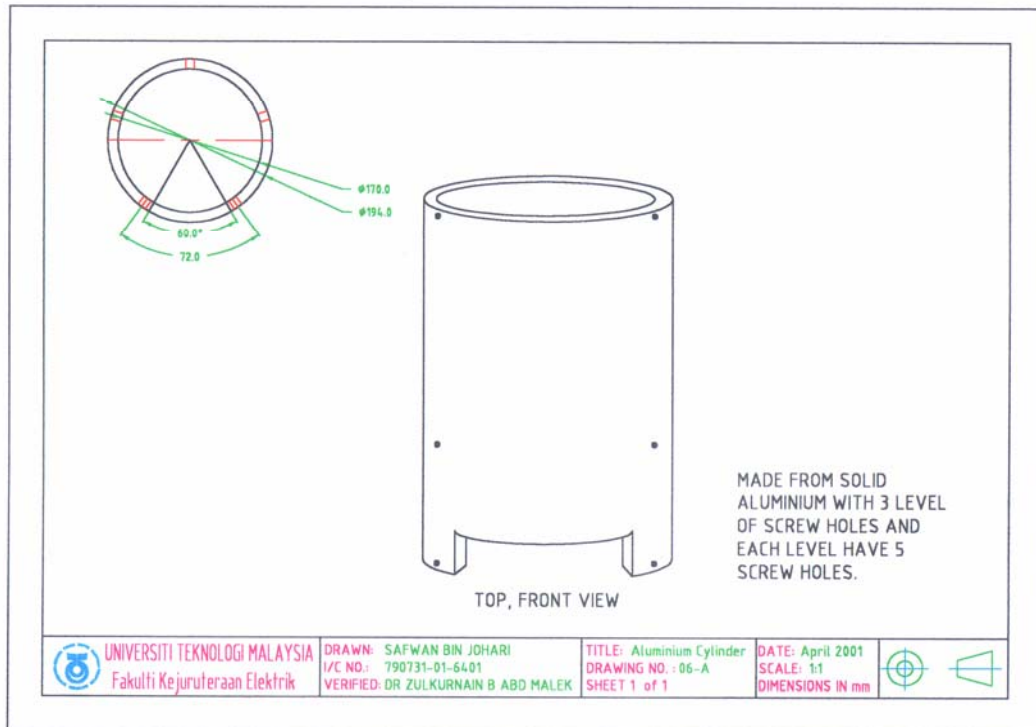

Figure 4.15 Aluminium Cylinder 1

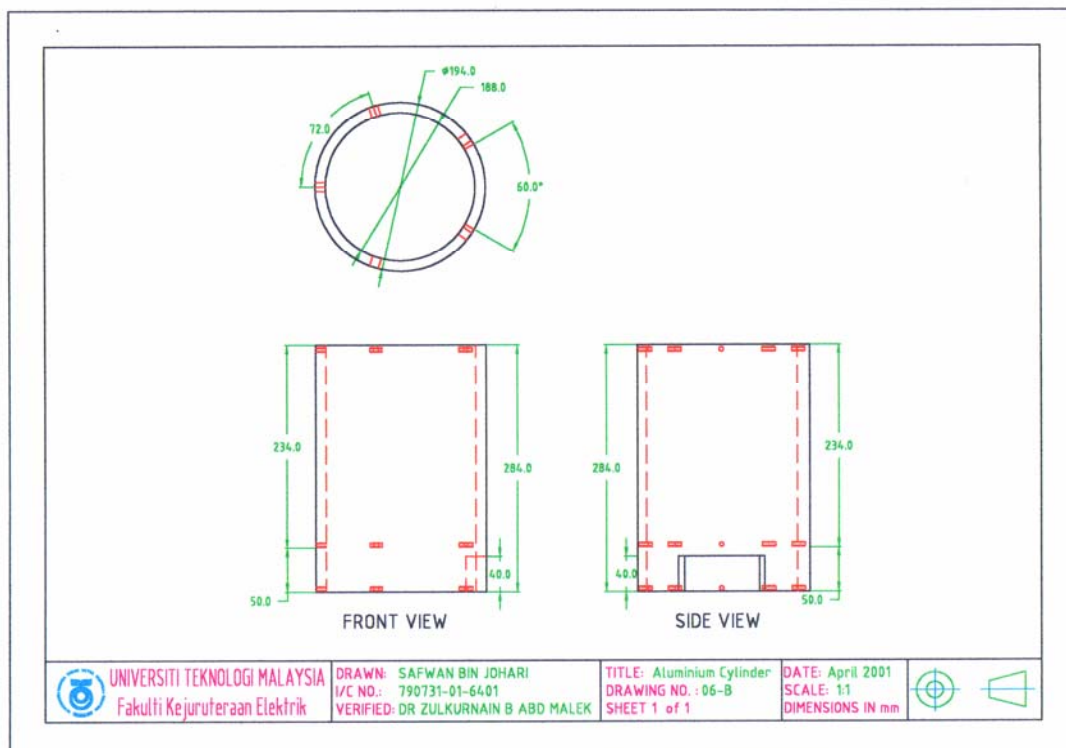

Figure 4.16 : Aluminium Cylinder 2

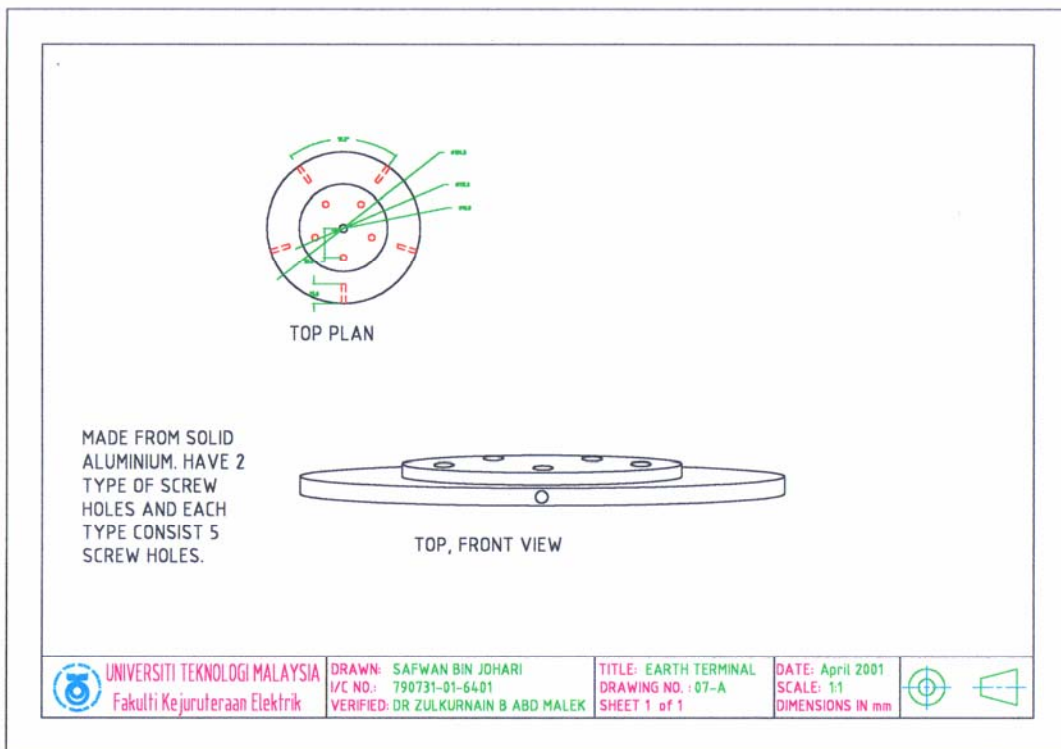

Figure 4.17 : Earth Terminal

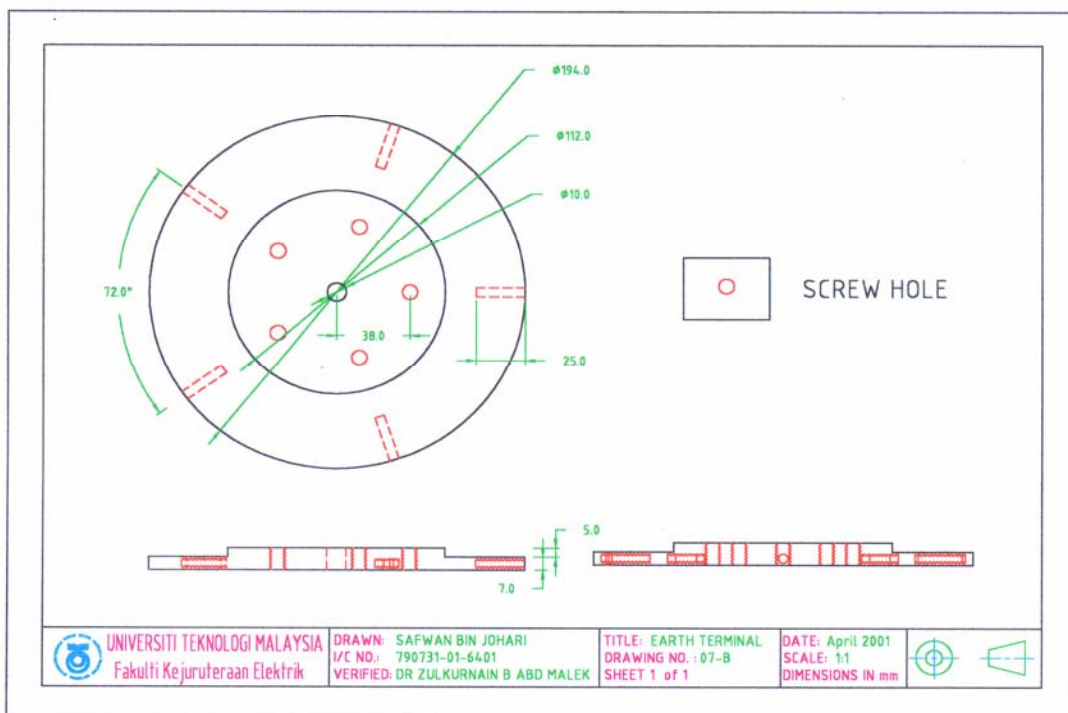

Figure 4.18 : Earth Terminal 2

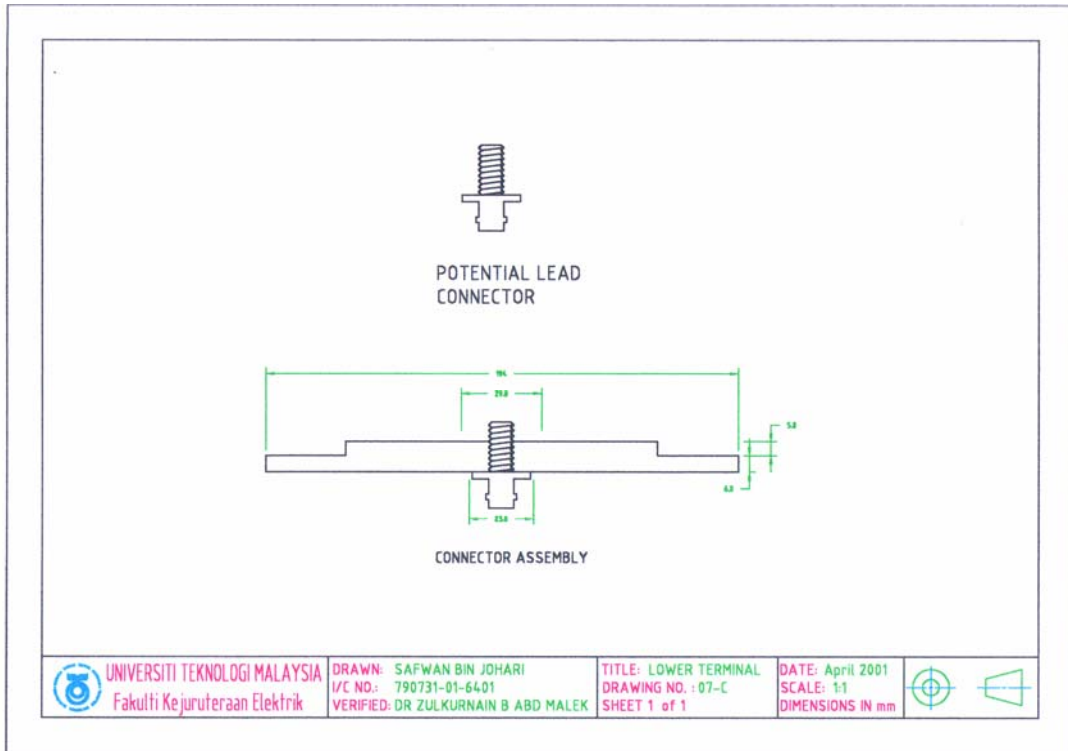

Figure 4.19 : Lower Terminal

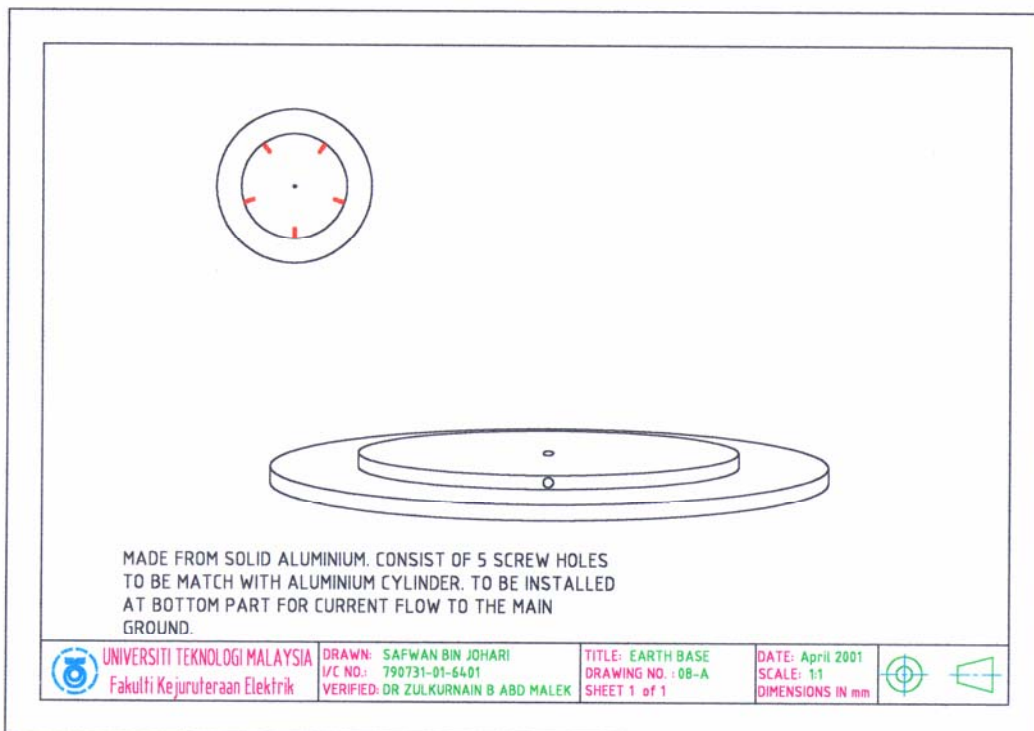
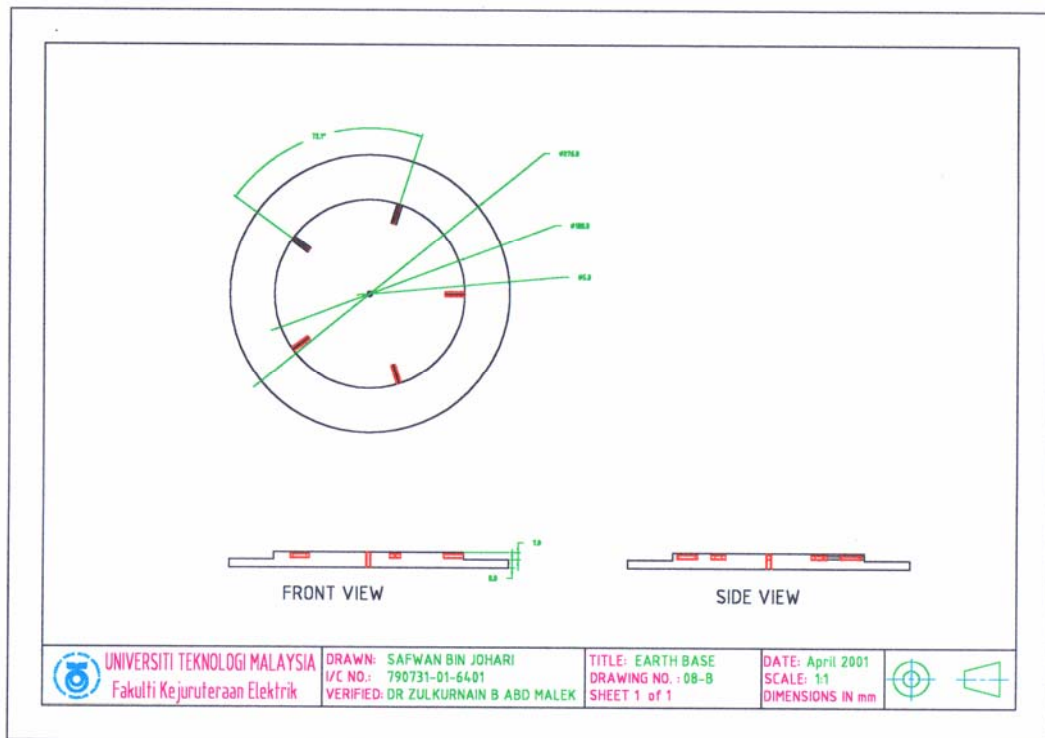

Figure 4.20 : Earth Base



**Figure 4.21 : Earth Base 2**

## CHAPTER 5

### CONCLUSIONS AND SUGGESTIONS

#### 5.1 Conclusion

This work dealt with theoretical consideration in designing resistive tubular shunt for measurement of current pulse with peak magnitude approximately 10kA and pulse duration approximately 10 $\mu$ s. The design of the 10kA impulse current shunt was successfully carried out including specific identification of materials to be used. The shunt was also successfully constructed. However, the test could not be carried out due to the insufficient resources to complete the last activity in the construction, that is, the soldering of the nickel chromium onto the aluminium.

## **5.2 Suggestion**

Due to the limited time and resources the completion of construction and the testing of the current shunt could not be carried out. It is suggested that the work is to be further continued in a future project.

## REFERENCES

- [1] O.B.Olivera, M.T.Silva and F.A.Chagas(1991). "Design, construction and performance evaluation of shunts for the measurement of high impulse current." Brasil: Centro de pesquisas de Energia Electrica.
- [2] Paul Naylor (1995). "The transient response of high voltage surge arresters." School of Engineering, Electrical Division, University of Walse, Cardiff: Phd Thesis.
- [3] G.R.Turner and I.W.Hofsajer(1999). "Rogowski coil for short duration pulsed current measurement." Johannesburg: Rand Africaans University.
- [4] D.A.Ward(1993). "Measurement of current using Rogowski coils." London: IEE Savoy Place.
- [5] L.B.Cronin and C.J.Kemp(1992). "Current shunts and resistors in use in NAMAS accredited laboratories." U.K: National Laboratory, Teddington, Middlesex.
- [6] C.M.Johnson(1981)."Current measurement using compensated coaxial shunts. "Cambridge University Department.
- [7] Alf J. Schwab (1970). "Low-resistance shunts for impulse currents."New York: IEE Power Engineering.
- [8] C.M Johnson and P.R. Palmer (1994). "Current measurement using compensated coaxial shunts."Newcastle: Department of Electrical and Electronic Engineering.
- [9] M.S.Naidu and V.Karamju(1995). "High voltage engineering." New Delhi:Mc Graw Hill.
- [10] E.Kuffel and M.Abdullah(1970). "High voltage engineering." Hungary:Pergamont Press.
- [11] E.Thornton(1992). "Diagnostic of pulse current and voltage." Soweby Reserch Centre.