

*Proceedings of the 5<sup>th</sup> Asia-Pacific Structural Engineering and Construction Conference (APSEC 2003)  
26 – 28 August 2003 Johor Bahru, MALAYSIA*

## **ULTIMATE LOAD PREDICTION FOR TIMBER BEAM - ELASTO-PLASTIC THEORY APPROACH**

Suhaimi Abu Bakar<sup>1</sup>, Abd. Latif Saleh<sup>2</sup> and Zainai B Mohamed<sup>3</sup>

<sup>1</sup>Lecturer, Universiti Teknologi Malaysia.

<sup>2</sup>Associate Professor, Universiti Teknologi Malaysia.

<sup>3</sup>Professor, Universiti Teknologi Malaysia.

**Abstract.** *Timber is one of engineering materials that behaves elasto-plastic property. However, the number of research that considers the elasto-plastic property of timber to analyse or to predict ultimate load of timber beam is limited. The application of perfectly elasto-plastic property for timber is proposed to predict the ultimate strength of solid and glulam beams. Three yield criteria for timber are introduced, i.e. yield criterion I, II and III. All criteria are developed based on orthotropic and microstructure property of timber. The existing criteria proposed by Tsai-Wu and Hill are also considered. These criteria were used to develop the theoretical model in order to predict the ultimate load of timber beams (solid and glulam). The ultimate loads predicted by perfectly elasto-plastic model (using yield criterion III) are in close agreement with experimental results. The predicted load-deflection curves using perfectly elasto-plastic model (using yield criterion III) is found to be approaching experimental load-deflection curves for most beams. Therefore this shows that the timber can be idealised as a perfectly elasto-plastic material. It can be concluded that the yield criterion III is the best criterion for solid and glulam timber beam. This new yield criterion is significant for development of theoretical model to predict ultimate load for timber beam.*

### **1. Introduction**

Simple elastic approach is normally applied to analyse timber beam structure. This approach assumes that the beam is elastic up to failure. However, timber behaves elasto-plastic property and there is a lack of research to consider this property to predict ultimate load of the beam.

Existing code of practices proposed elastic approach to predict ultimate strength of timber beam [1, 2]. In the ASTM D3737-92, the method of transformed section is proposed to predict ultimate strength and to take account the effect of inhomogeneity that present in glulam beam structure. A number of USDA researchers [3, 4, 5, 6, 7] applied a method of transformed section to predict ultimate strength of timber beam. Those researchers assumed that timber property is elastic up to failure and neglecting the actual property of timber, i.e. elasto-plastic.

A few researchers such as Nwokoye, Bazan, Zakic and Buchanan [8, 9, 10,

11] consider elasto-plastic property of timber to predict ultimate strength of timber beam. The prediction of ultimate strength is based on simplified stress-strain curves and considering force equilibrium in typical section of the beam. However, elastic analysis is still applied to predict ultimate strength. Nwokoye [8] simplified the stress-strain curve as perfectly elasto-plastic curve. Bazan and Buchanan [9,11] simplified strain-softening part of stress-strain curve as linear relationship. On the other hand, Zakic [10] simplified the elastic part as parabolic and plastic part as perfectly plastic curve.

The application of perfectly elasto-plastic theory is widely used to analyse soil structure but limited for timber structure [12]. The load predicted by this theory converges to certain amount and after that the load is remain constant. The constant load is called a limit load or a collapse load  $P_c$ . An excessive amount of deformation occurred when the load approaching  $P_c$  and the material is assumed fails at this stage. The typical load-deflection curve under perfectly elasto-plastic theory is as shown in Figure 1.

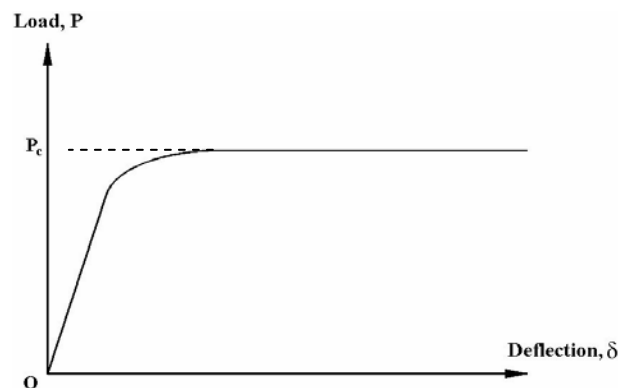

Figure 1 Typical plastic collapse phenomenon and definition of limit load

Under perfectly elasto-plastic theory, the material is assumed yield when the stress states in the yield locus diagram reaches the boundary of yield locus and depend on the type of yield criteria. There are a few types of yield criteria, but only two of them match to timber. Under Hill's criterion [13], the orthotropic property of material is considered and the material is yielding if distortion strain energy approaches a critical value. Hill proposed an ellipse shape for yield locus and centred at origin point.

The application of Hill's theory is limited for the material that not influenced by Bauschinger effect. Timber is influenced by Bauschinger effect, thus, the application of Hill's criterion is conflicted to timber property in certain case.

In order to consider the Bauschinger effect that presents in orthotropic material, Tsai and Wu [14] modified Hill's ellipse and shifted to a new position. The

centre of the ellipse is not at the origin point. The different values of uniaxial yield stresses in compression and tension are considered.

The yield criterion proposed by Tsai and Wu is an improvement to Hill's criterion. However, Tsai and Wu proposed an ellipse shape for yield locus and verified to graphite-epoxy material. From existing researches related to timber material, however, there are no reports that consider the ellipse shape of yield locus for timber material.

The elasto-plastic property of timber was documented by Suhaimi and Zainai [15]. Timber can be idealised as a perfectly elasto-plastic material. The stress-strain curves obtained from compression tests (parallel and perpendicular to grain tests) converge to perfectly elasto-plastic curves. The load-deflection curves from beam test also converge to perfectly elasto-plastic curves. The plastic property of timber is also found significant.

The idealisation of timber as perfectly elasto-plastic material and the application of perfectly elasto-plastic model to analyse timber beam structure may become the initial stage and useful part in the design of timber beam structure. The actual property (elasto-plastic) of timber is considered, thus the application of perfectly elasto-plastic model to predict the close possible value of ultimate load becomes possible.

## **2. Perfectly elasto-plastic model**

Perfectly-elasto plastic model can be represented in Figure 2. The yield locus in this figure represents the strength of timber. Any stress state ( $\sigma_x, \sigma_y, \tau_{xy}$ ) in the yield locus can not exceed the boundary of yield locus. Any stress state inside the yield locus (such as point A and B) corresponds elastic behaviour of the material. The plastic flow ( $d\epsilon^p$ ) is assumed take place when the stress state reaches yield locus (such as point C and D in Figure 2). To ensure the work increment due to external load is always positive value, the yield locus should be convex and the plastic strain increment vector,  $d\epsilon^p$ , at any point of the yield locus is normal and outward direction to the yield locus. The plastic strain increment vector,  $d\epsilon^p$ , is related to the yield function,  $f$ , as follow [12]:

$$d\epsilon_{ij}^p = \lambda \partial f / \partial \sigma_{ij} \quad (1)$$

Where  $\lambda > 0$  is a positive scalar proportionality factor. 'i' and 'j' are the parameters that relates to coordinate axes, x and y. Equation 1 is a well known as normality rule.

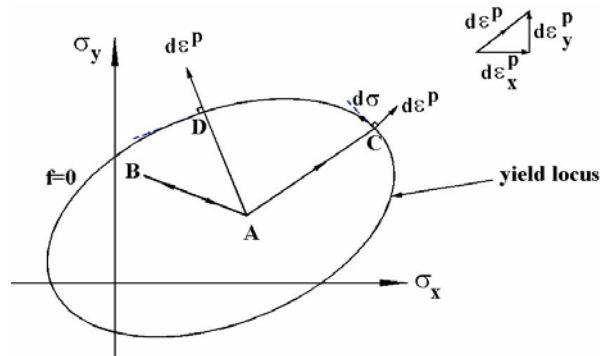

Figure 2 A pictorial representation of perfectly elasto-plastic model

The plastic work increment is assumed equal to zero and can be stated as a dot product between two vectors  $d\sigma$  and  $d\epsilon^p$ , as follow:

$$dW^p = d\sigma \cdot d\epsilon^p = 0 \quad (2)$$

Equation 2 indicates that both vectors are perpendicular. The stress increment vector,  $d\sigma$ , is perpendicular to the strain increment vector,  $d\epsilon^p$ , and its direction is along the tangential line of the yield locus (refer Figure 2). Thus, all stress states are allowed to move along the yield locus and can not exceeded outside region of the yield locus.

### 3. Possible yield criteria for timber

Three possible yield criteria for timber are introduced and namely as yield criterion I, II and III. All criteria are develop based on orthotropic property of timber or behave different value of uniaxial yield stress according to timber axes. The possible yield criteria were introduced to overcome the limitation of existing yield criteria discussed in Section 1.

#### 3.1. Yield criterion I

Yield criterion I is proposed to consider the different values of uniaxial yield stresses according to orthotropic axes and to take into account the effect of Bauschinger that presents in timber. Under a combination of stresses  $\sigma_x$  and  $\sigma_y$  (see Figure 3), the timber is assumed yield if the stress  $\sigma_x$  reaches anyone of the uniaxial yield stress  $X_c$  or  $X_t$ , or the stress  $\sigma_y$  reaches anyone of the uniaxial yield stress  $Y_c$  or  $Y_t$ . The possible yield locus diagram under yield criterion I is shown in Figure 4.

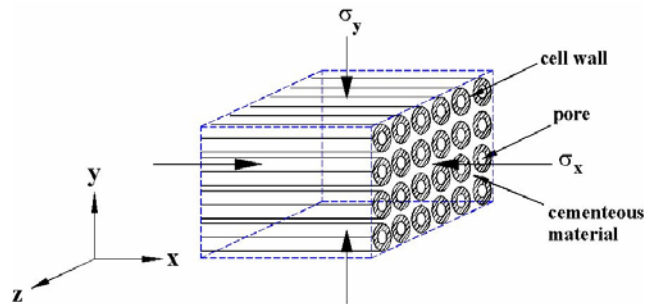

Figure 3 An element of timber subjected to normal stresses  $\sigma_x$  and  $\sigma_y$

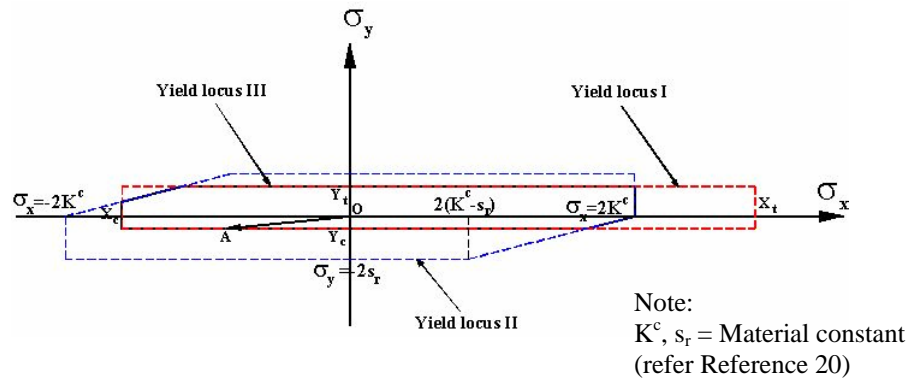

Figure 4 Yield locus I, II, III

### 3.2. Yield criterion II

Yield criterion II is developed based on Tresca's criterion and improvement has been made to consider orthotropic property of timber [16]. The material is assumed yield if the shear stress at any plane of timber's element (refer Figure 3) approach a critical value or shear strength. The shear strengths are assumed unequal value according different directions in the timber's element. The yield locus diagram under this criterion (namely as yield locus II) is shown in Figure 4.

### 3.3. Yield criterion III

A new yield locus, namely as yield locus III, is superimposed from yield locus I and yield locus II and take account of the Bauschinger effect (unequal values of compression strength and tension strength) that present in timber. It is the next possible yield locus for timber. Under yield criterion III, the material is assumed

yield if the shear stress at any plane of timber's element approaches a critical value, or normal stresses ( $\sigma_x$  or  $\sigma_y$ ) reach its yielding values. The yield locus III is shown in Figure 4. Any points on the yield locus III should be inside or at the boundary of both types yield locus I and II. For example, the point A (see Figure 4), which is on yield locus III is inside of yield locus II and at the boundary of yield locus I.

#### 4. Experimental tests

Experimental tests were conducted to verify the perfectly elasto-plastic model for timber. Four solid beams and four glulam beams made up of Meranti timber were prepared and tested according to ASTM D198-84 [17]. The beam is tested according to two point loads. The dimension of the beam is shown in Figure 5. The beam size is design so that the failure of beam occurred in the region of bending.

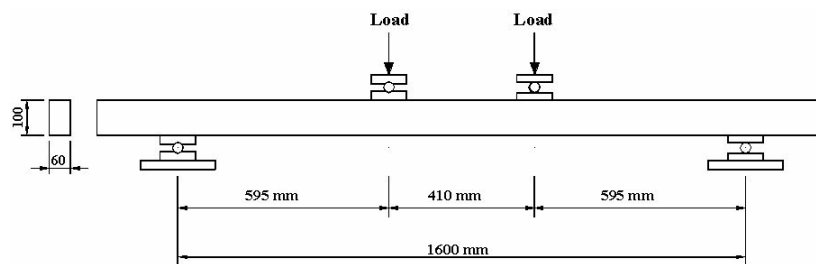

Figure 5 The beam test

#### 5. Analytical model and elasto-plastic analysis

Analytical model is developed based on boundary element method by incorporating the perfectly elasto-plastic property for timber material. The development of analytical model is discussed in detail in references [18] and [19].

The elasto-plastic analysis is applied to analyse all solid beam and glulam beam specimens. Several yield locus as outlined in Section 3 and existing yield locus as outlined in Section 1 were considered in the proposed analytical model. The typical yield locus is shown in Figure 6 and was plotted based on experimental results given in reference [18].

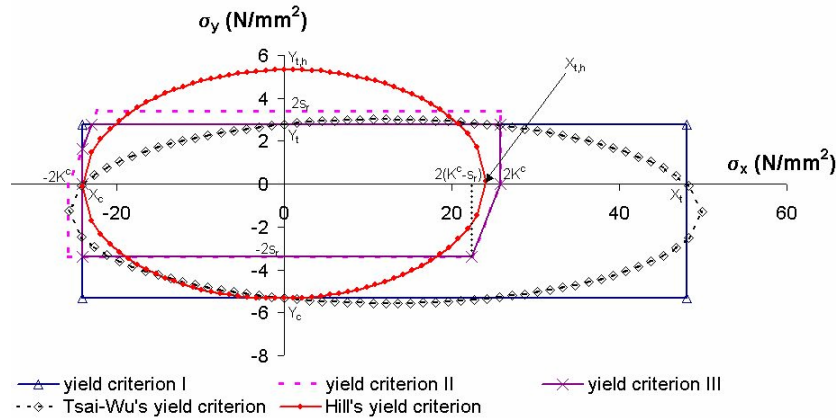

Figure 6 Typical yield locus diagram for Meranti timber

## 6. Analytical predictions and comparison with experimental results

The load-deflection curves are plotted based on the result of elasto-plastic analysis. The typical curves are shown in Figure 7. Figure 7(a) shows load-deflection curves for solid beam specimen, while Figure 7(b) shows load-deflection curves for glulam beam specimens. Five load-deflection curves were plotted in each diagram. The first curve is plotted based on yield criterion I prediction, while other curves are plotted based on the predictions using yield criteria II, III and existing yield criteria proposed by Tsai-Wu and Hill. The load-deflection curve from experimental data is also plotted in each diagram for comparison and to verify the perfectly elasto-plastic model for timber.

From Figure 7, the load-deflection curves from perfectly elasto-plastic predictions are linear at elastic stage and non-linear at plastic stage. At the linear stage, the load-deflection curves (for all types of yield criteria) coincide with experimental curve. The slope of load-deflection curves decreased at non-linear stage. At a certain part of load-deflection curves, the slope approach to zero and the curves extends toward horizontal direction. At this stage, the limit load is reached.

It is found that the value of limit loads varies according to the types of yield criteria and shows that the values of limit load are dependent to the type of yield criterion. The limit load is greater for yield criterion I and Tsai-Wu's then followed Hill's criterion and yield criteria II or III. The limit loads from yield criteria I and Tsai-Wu are approximately equal. On other hand, the limit load from yield criteria II and III

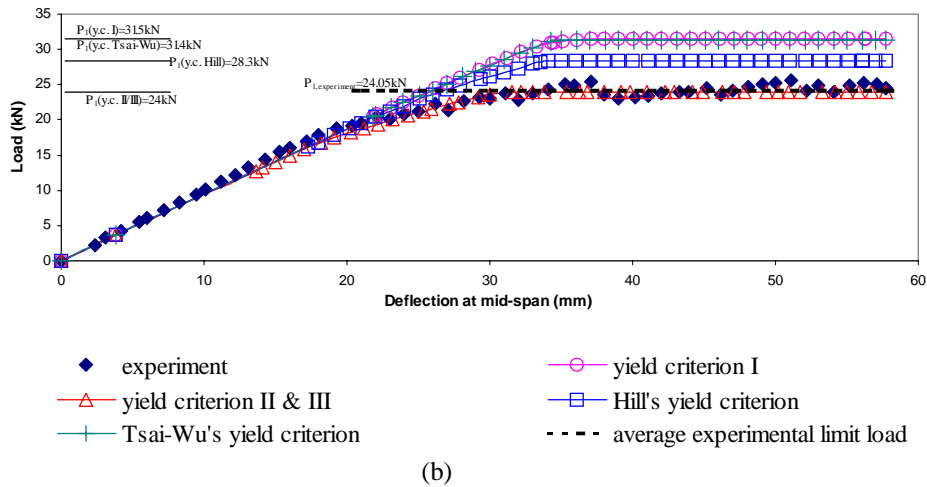
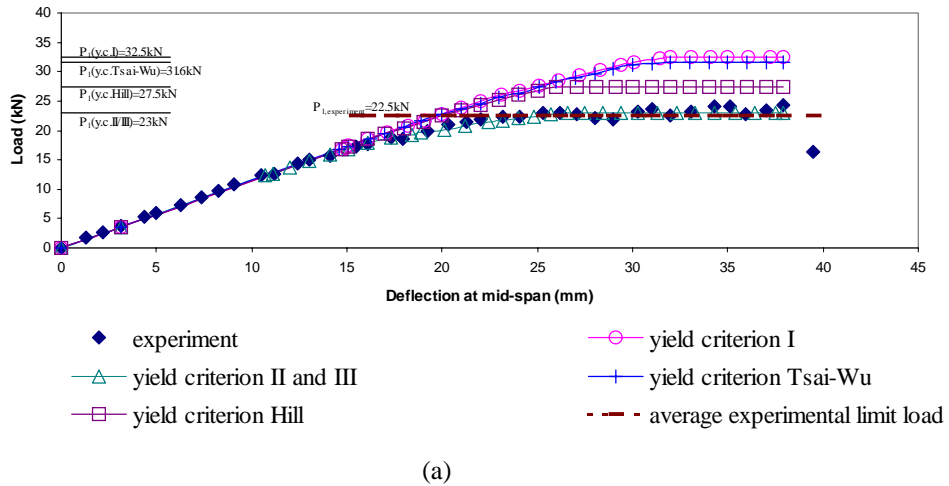

Figure 7 Typical load-deflection curves for (a) solid, (b) glulam beam specimens

are almost equal. In addition, the load-deflection curves from yield criteria II and III are seen coincide.

For solid and glulam beams, the load-deflection curve from yield criteria II and III are found approaching to experimental curve at elastic and plastic stage. The limit load from these criteria is approaching to experimental limit load. The load-deflection curves from other yield criteria give bad predictions in comparison with experimental curve.

By referring to Figure 6, yield locus II and III are approximately coincide and shows that the yielding of timber material under yield criteria II and III are



approximately equal. Thus, the limit load prediction using yield criteria II and III gives same result. However, yield criterion III is much reliable due to the consideration of Bauschinger effect (refer Section 3.3).

The prediction of ultimate load using perfectly elasto-plastic model (using yield criteria III) is found good for Meranti beam. Based on reference [18], the predictions of ultimate load using yield criterion III are capable to give good result for most solid and glulam beam specimens. The mathematical errors for ultimate load is relatively small compared with actual ultimate load for most beam specimens. The application of perfectly elasto-plastic model using yield criterion III is proposed for Meranti beam.

## **7. Concluding remarks**

To conclude this paper, the following remarks are noted:

1. The comparison of perfectly elasto-plastic prediction and experimental results can strengthen the idealisation of Meranti timber as perfectly elasto-plastic material.
2. Based on load-deflection curve, the plastic property of timber is found significant.
3. The ultimate load prediction using perfectly elasto-plastic model (using yield criterion III) is in close agreement with actual ultimate load. The load-deflection curve predicted by this model almost coincides with experimental curve.
4. The prediction of ultimate load using perfectly elasto-plastic model is found good and proposed for Meranti beam. This model considers actual elasto-plastic property of timber and capable to give exact prediction for ultimate load.

## **References**

1. British Standard Institution (Part 2), *Structural Use of Timber: Part 2. Code of practice for permissible stress design, materials and workmanship*, London (BS 5268), 1991.
2. American Society for testing and materials, *Standard test Method for Establishing Stresses for Structural Glued Laminated Timber (Glulam)*, ASTM D3737-92, 1992, pp. 486-501.
3. Rammer, D.R., 'Shear strength of glued-laminated timber beams and panels', *Research Report*, Forest Products Laboratory, USDA Forest Service, 1996.
4. Shedlauskas, J.P., Manbeck, H.B., Janowiak, J.J., Hernandez, R., Moody, R.C., Labosky Jr., P., Blankenhorn, P.R., 'Efficient use of red oak for glued-laminated beams', *ASAE Paper No. 94-4575*, Vol. 39, No. 1, 1996, pp. 203-209.
5. Hernandez, R., Moody, R.C., 'Analysis of glulam timber beams with mechanically graded (E-rated) outer laminations', *Proceedings of the international wood engineering conference*, Vol. 1, 1996, pp. 144-150.

6. Manbeck, H.B., Janowiak, J.J., Blankenhorn, P.R., Labosky Jr., P., Moody, R.C., Hernandez, R., 'Efficient hardwood glued-laminated beams', *Int. Wood Engineering Conference*, Vol. 1, 1996, pp. 283-290.
7. Janowiac, J.J., Manbeck, H.B., Hernandez, R., Moody, R.C., 'Red Maple lumber resources for glued-laminated timber beams', *Forest Products Journal*, Vol. 47, No. 4, 1997, pp. 55-64.
8. Nwokoye, D.N., 'An investigation into an ultimate beam theory for rectangular timber beams - solid and laminated', *Research Report E/RR/34*, 1972.
9. Bazan, I.M.M., *Ultimate bending strength of timber beams*, PhD Theses, 1980.
10. Zakic, B.D., 'Inelastic bending of wood beams', *Journal of the Structural Division*, Vol. 99, No. ST10, 1973, pp. 2079-2095.
11. Buchanan, A.H., 'Bending strength of lumber', *Journal of Structural Engineering*, Vol. 116, No. 5, 1990, pp. 1213-1229.
12. Chen, W.F., *Limit Analysis and Soil Plasticity*, Elsevier Scientific Publishing Company, 1975.
13. Hill, R., *The Mathematical Theory of Plasticity*, Oxford (1951)
14. Tsai, S.W., Wu, E.M., 'A General Theory of Strength for Anisotropic Materials', *J. Comp. Mat.*, Vol. 5, No. 1, 1971, pp. 58-80.
15. Suhaimi, A.B., Zainai, M., 'The possibility to idealise structural timber as a perfectly elastic-plastic material', *Malaysian science and Technology Congress 2000*, COSTAM, 2000.
16. Suhaimi, A.B., Abd Latif, S. and Zainai M., 'An Improvement of Tresca's criterion for the Analysis of Timber Structure', *5th Asia Pacific Structural Engineering & Construction Conference*, 2003.
17. D198-84, *Standard Methods of Static Tests of Timbers in Structural Sizes*, 1992 Annual Book of ASTM Standards.
18. Suhaimi, A.B., *Ramalan kekuatan muktamad bagi rasuk kayu padu dan rasuk glulam - Penggunaan teori elastik-plastik (Ultimate strength prediction of solid timber beam and glulam beam - Elasto-plastic theory approach)*, PhD Theses, UTM, 2003.
19. Suhaimi, A.B., Zainai M., Abd Latif, S., 'An improved strain incremental formulation in boundary element method applied to a timber beam at the moment of failure', *4th Asia Pacific Structural Engineering & Construction Conference*, 2000.