

Enhancing the Performance of a 125 cc Single-cylinder, Air-cooled, Gasoline Two-stroke Engine

A. Abdul Aziz, Z. Abdul Latiff, M. Fawzi Mohd Ali, M. Farid Mohammad Said & M. Said

Automotive Development Centre (ADC)

Faculty of Mechanical Engineering

Universiti Teknologi Malaysia (UTM)

azhar@fkm.utm.my

Abstract: A unique stepped-piston engine was developed by a group of researchers at UTM. The development work engulfs design, prototyping and testing over a predetermined period of time. The aim is to demonstrate environmental-friendly capability producing comparable output with low-fuel consumption. In its carbureted version, it incorporates a three-port transfer system and a dedicated crankcase breather. These features will enable the prototype to have high induction efficiency and to behave very much a two-stroke engine but equipped with a four-stroke crankcase lubrication system. In the final stage of development it was subjected to a series of laboratory trials. It was also tested on a small watercraft platform with promising indication of its flexibility of use as a prime mover in mobile platform. In an effort to further enhance its technology features, the researchers have embarked on the development of an add-on auxiliary system. The system comprises of an engine control unit (ECU), a direct-injector unit, a dedicated lubricant dispenser unit and an embedded common rail fuel unit. This support system was incorporated onto the engine to demonstrate the finer points of environmental-friendly and fuel economy features. The outcome of this complete package is described in the paper, covering the methodology and the final characteristics of the mobile power plant.

Keywords: stepped, gasoline, two-stroke, injector and single

1. Introduction

Two-stroke engines have been in used for sometimes in automotive and stationary applications since early 1900. The advantages of two-stroke engines are i) lighter, ii) simpler and iii) less expensive to manufacture. Two-stroke engines also have the potential to pack almost twice the power into the same space because there are twice as many power strokes per revolution. The combination of lightweight and twice the power gives two-stroke engines a great power-to-weight ratio compared to many four-stroke engine designs. However due to the short-circuiting of the fuel before combustion, this has resulted in deterioration in overall performances especially poor combustion efficiency and high white smoke emission problem. Coupled with the improvement in the four-stroke engine technology, the former has overcomes the latter in being the choice for mobile platform applications. With the problem of high fuel cost and the need to explore the use of other fuel sources, most notably hydrogen, the two-stroke engine design has been revisited by a number of researchers and engine developers where hydrogen utilization is said to be ideal for use with the incorporation of some new features [1].

An engine design and development program was initiated in UTM (2002 to 2005) to develop local R&D capabilities in small power-train engineering. The exercise evolved around the development of an air-cooled single cylinder stepped-piston engine concept. The changes to the original design were made, as there were rooms for improvements. In addition the modifications are able to provide innovative scope of work from design to testing activities [2]. The program eventually leads to the incorporation of features, which will enhance its performance as well as emission. This is in anticipation of producing a working prototype with multiple non-automotive and automotive platform applications.

The gasoline stepped-piston engine is a relatively new design concept for small mobile power plants. It is an engine that operates on a two-stroke cycle but is infused with four-stroke engine features. It has a build-in supercharger mechanism that improves the scavenging process thus improve combustion efficiency. As a result of these operating characteristics, the engine has all the attributes of a low emission, high-efficiency power plant that eliminates many of the major weaknesses associated with the Otto four-stroke engine and with modern two-stroke engines.

2. Engine Concept

The work on stepped-piston engines was known to be undertaken by Bernard Hooper [1]. The unique feature lies in the piston geometry i.e. two concentric pistons combined into one solid piece.

Figure 1 (a) and (b) illustrate the engine design in detail. The double diameter pistons work inside a cylinder, which is correspondingly bored to two different diameters, the smaller providing a normal piston-ported 2-stroke cylinder and combustion chamber and the larger annular pumping chamber. The intake charge is drawn into the annual space through a reed valve, which will close automatically when the piston reaches BDC and starts to ascend again. It is then discharges through the transfer ports into the combustion chamber of the other cylinder, scavenging any exhaust residuals in the process, until the exhaust ports are closed by the rising piston and compression starts.

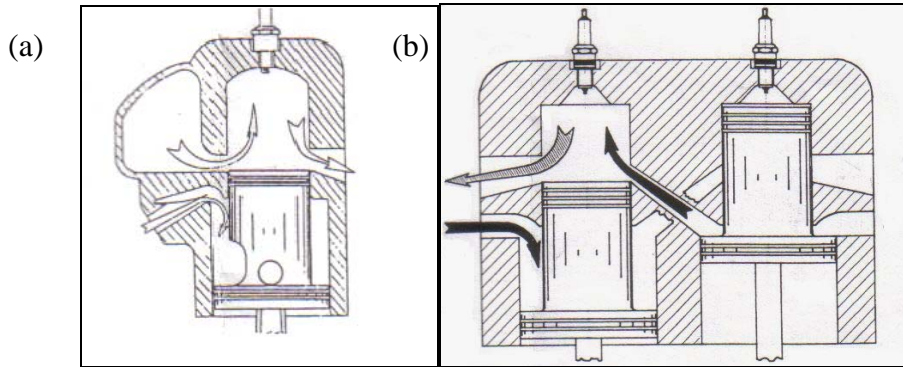

Figure 1: (a) Single-cylinder and (b) multi-cylinder arrangements [2].

Figure 2 illustrates the configuration made by the UTM researcher on the single cylinder stepped-piston design by passing through a parallel arrangement of intricate portings, leading to the main combustion chamber.

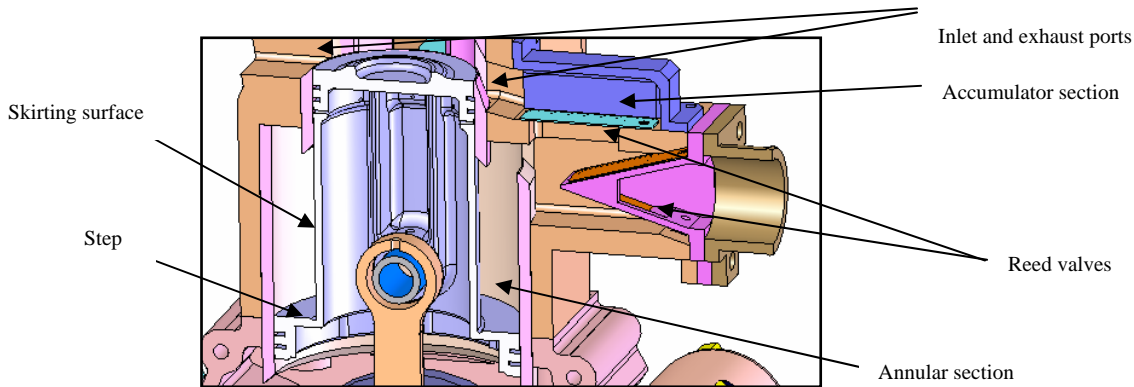

Figure 2: The cross-sectional area of the engine.

The step and the skirting surface of the piston combined to act as a pump to induce fresh mixture during the expansion stroke. During the compression-stroke the mixture will be compressed and pass through a set of reed valves and to the transfer ports into the main combustion chamber. When the piston surface covers completely the inlet ports, the trapped air in the annular section will be guided to a set of simple accumulators (not shown) which will dampen the pressure surge and the which the air now trapped will expel completely the exhaust gas of the previous cycle.

The research group has made some innovative changes to the design proposed by Hopper. The major changes are i) a three-port transfer system ii) shallow bowl-in-piston geometry, iii) air-charge system and iv) port timings. The engine will be incorporated with a direct fuel injector (DFI) position perpendicular to the flat surface of the piston. The spark plug is positioned 30° in relation to the vertical axis. This is to provide an ideal configuration in providing a stratified-charge combustion feature if lean-burn combustion strategy is to be use effectively in this engine. The detail of the engine design, timing and its specifications are given in Figure 3, Figure 4 and Table 1 as shown below.

Table 1: General specifications

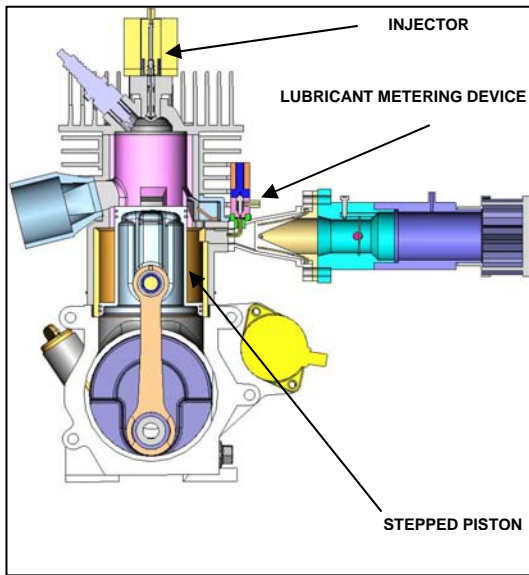

Figure 3: (a) The stepped-piston engine cross-sectional area.

Parameter	Size/Feature
Capacity (cc)	125
Bore (mm)	54.2
Stroke (mm)	54.2
Compression ratio	9.6
Ignition system	Capacitive-Discharge
Fuel/scavenging systems	Direct-fuel injection/ multi-port loop scavenge
Cooling	Air-cooled
Starting	Starter motor
Max. power, kW@rpm	7.6@7500
Calc max. torque, Nm@rpm	12.5@5000
Power-weight ratio (kW/kg)	0.46

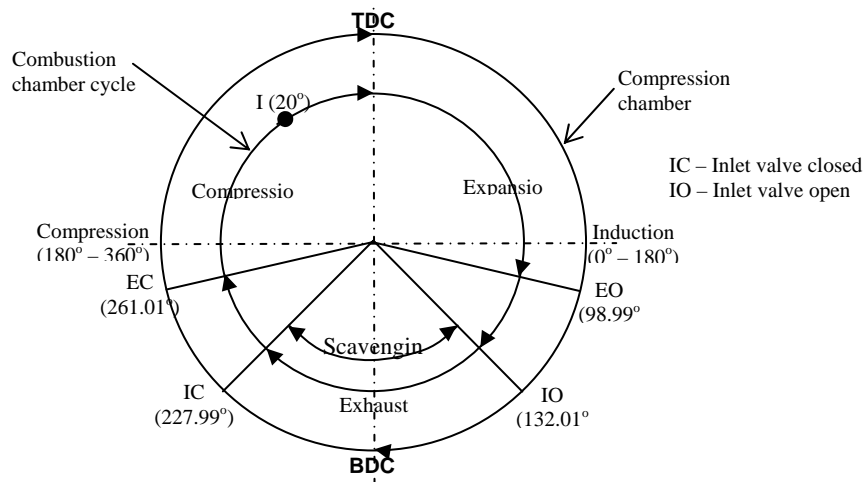

Figure 4: Engine timing diagram

3. Engine Sub-Systems

The improvised version of the engine features the incorporation of the following in-house technologies:

Lubricant-dispensing unit. This is a built-in unit incorporated in the engine crankcase and synchronized with the engine crankshaft. Its sole purpose is to dispense an exact amount of lubricant onto the surface of the piston skirt. It is important to highlight that the metering is done not for every engine cycle but periodically. In doing so, will minimize the 'carry-over' effect of the lubricant into the combustion chamber thus drastically reduce the emission of heavy unburnt hydrocarbons. The engine's electronic control unit controls the timing for the dispensing.

Breather unit. The purpose of its installation is to trap the carry-over in the air charge of the engine crankcase during operation. Since the engine partially behaves like a four-stroke engine, the lubricant in the crankcase is periodically subjected to induction (via vent hole) and compression. As such crankcase air will leave the crankcase with substantial

amount of lubricant with it. Very soon the lubricant will be left to a minimum level and this will be catastrophic to the moving parts within the crankcase. To avoid this a dedicated breather unit was constructed and upon extensive evaluation was found to have a trapping efficiency of 99.3%.

Electronic Fuel Injector Controller (EFIC). The unit is designed as a compact unit and installed directly to the engine. It contains a printed circuit board (PCB) with electronic components. The CPU with onboard RAM and ROM will minimize the interface components. Pulse width modulation (PWM) for the fuel injector is done by a timer, which has been programmed to control the output pulse width. A multi terminal plug connects the EFIC to its sensors, injector, as well as to its power supply. The EFIC must withstand high temperature, humidity and physical stresses. The input signals for this EFIC are the engine speed, top dead center (TDC) marking and manifold absolute pressure (MAP). The MAP will be calibrated with the air-fuel-ratio (AFR) through experimental results. Performing thorough engine testing does the calibration process. The results then will be used as a look-up table, which will be programmed within the EFIC. Through sensors input, the best AFR will then be defined and correct mass of fuel will be injected to the combustion chamber. The amount of fuel injected will be control by PWM (output of the EFIC), which actuate the injector solenoid.

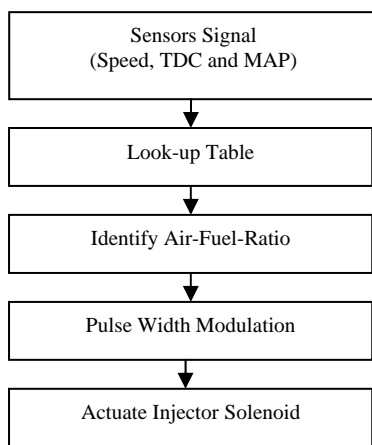

Figure 5: EFIC Flowchart



Figure 6: The prototype gasoline direct-injector

Fuel injection system. Figure 6 shows the gasoline direct injector developed for the engine. It consists of solenoid, casing, spring, needle, swirler, nozzle and lock. It features a hollow cone spray and capable of generating less than 20 micron droplet size. Also shown (Figure 7) is the dedicated direct fuel-injection system for the prototype engine. Here the fuel is pressurized by an axial-type mechanical pump, which is driven via the engine crankshaft. A pressure relief valve is attached to the high-pressure fuel line to maintain the fuel pressure at 5.0 MPa while excessive fuel is returned back to gasoline tank. To reduce the fluctuation of the fuel pressure, a small fuel accumulator is also attached to the high-pressure fuel line. The fuel injector used is a prototype pressure-swirl injector with a static flow rate of 480 cc/min rated at 5.0 MPa. The spray produced by this type of injector is a hollow-cone and its nominal spray half-cone angle is 32°. The injector is driven by control module located in the Electronic Fuel Injector Controller (EFIC). Connected to the EFIC are i) speed sensor, ii) crank angle sensor, and iii) manifold absolute pressure (MAP). These sensors serve as input parameter for the EFIC to determine the correct injection timing and pulse width at any speeds.

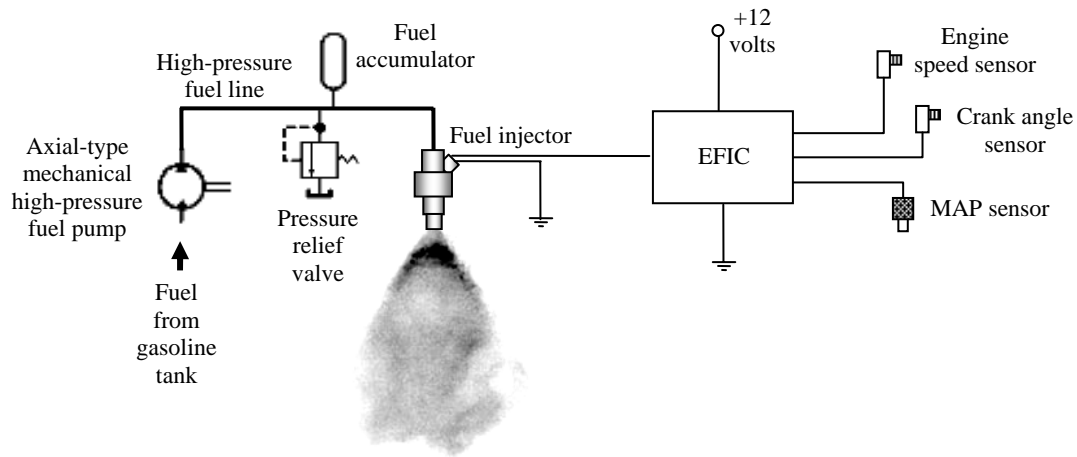

Figure 7: The schematic of the direct fuel injection system.

4. Laboratory and Field Trials

A 19-inch rack exhaust gas analyzer system (*TOCSIN IGD 300*), complete with a 3-meter sampling probe was used for emissions measurements. The engine was directly coupled to an eddy-current *MAGTROL* dynamometer equipped with a load controller. The engine, dynamometer and other auxiliary items are mounted on a seismic steel bed (2m x 4m) to cushion the excessive engine vibration emitted during the trial. Fuel consumption measurements were made using a precision *Ono Sokki* gravimetric fuel flow meter (the FP series, DF 0400/FM-2500). The BS 7698-1: 1993 standard for reciprocating engine test was used in the evaluation of engine performance parameters. The emission tests were conducted in parallel to the experimental work on the engine.

The results of the engine full load tests and emissions are shown in Figure 8 and 9 respectively. Figure 8 (a) indicates the profiles of specific fuel consumption parameter for the two engine versions. The results indicate the improvements made in fuel consumption, ranging from 5% to 7%, when the engine is equipped with the GDI fuelling system. This goes to explain that a small quantity of fuel saving can be made when precise metering is made with delivery directly into the engine's combustion chamber. The incorporation of the fuel injection system has also resulted in the improvement in the engine output, particularly from the mid-speed range onwards as shown in Figure 8 (b).

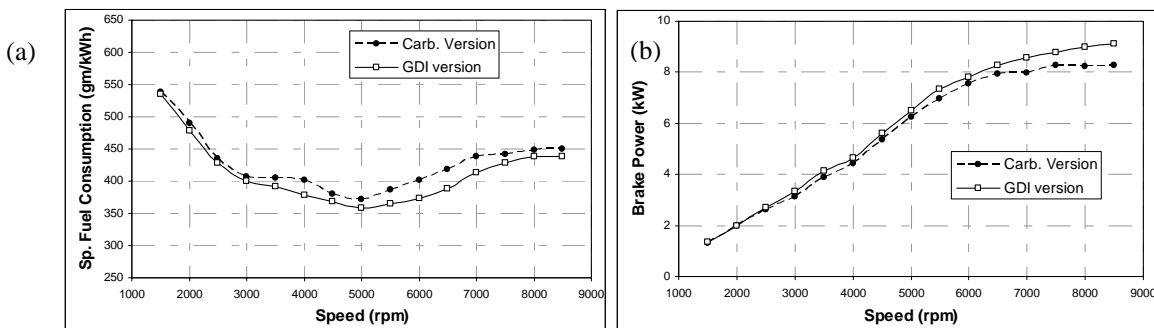

Figure 8: Fuel consumptions and engine outputs.

With gasoline engines combustion the critical emission by-products are i) carbon monoxide (CO) and unburnt hydrocarbon. These parameters were observed based on the numerous data gathered. With the incorporation of the injector unit onto the engine and with precise timing and metering the reduction of these two emission parameters is obvious. Reduction of CO concentration ranges from 25% to 30% from low to high speed (Figure 9 (a)). Similarly the reduction in unburnt hydrocarbon emission (Figure 9 (b)) is also pronounced. The reduction of these two toxic components of the emission is attributed to i) high utilization of air for combustion, ii) improve combustion efficiency and iii) reduction in fuel loss.

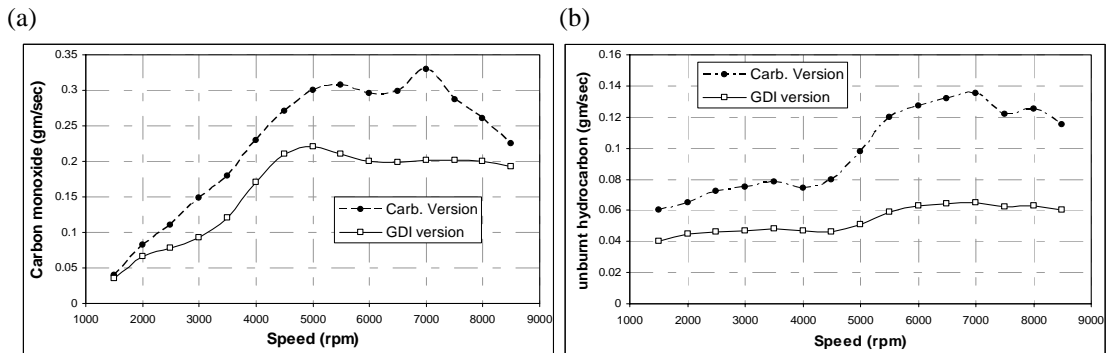

Figure 9: CO and unburnt HC concentrations.

To ascertain the practicality of the newly developed engine it was put on trial in a somewhat small-unmanned water surface craft (refer Figure 10). This is a craft, which is controlled remotely with coverage of 1 km in radius. The craft was tested for sometimes and has proven to be reliable and practical for use in non-automotive sector such as this. However the trials were made on the carbureted version rather than the direct-injection version due to some constrains.

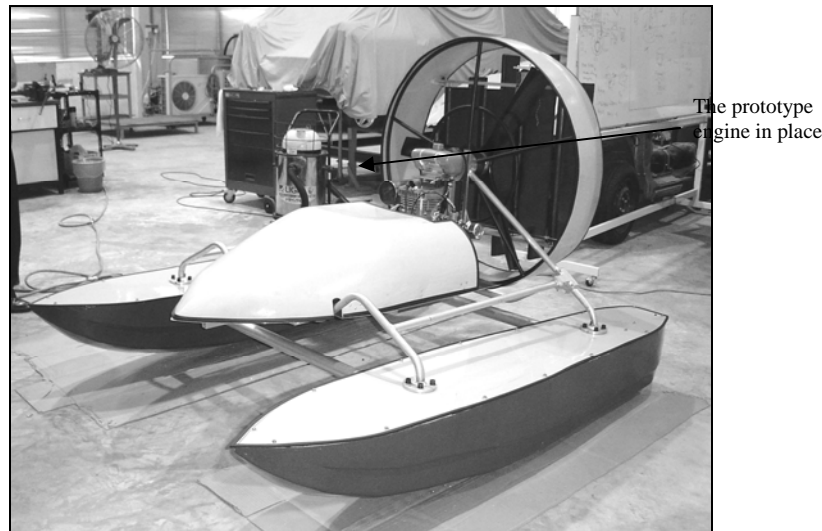

Figure 10: Mounting of the prototype engine onto a remotely piloted water surface craft.

5. Conclusions

The following conclusions are hereby derived:

1. A small-size gasoline engine of stepped-piston design has been successfully developed both for carbureted - and fuel-injection versions.
2. The improvements made on the carbureted version have strong indications of fuel having fuel economy and environmental-friendly features.
3. The incorporation of four new features have improved the engine performance and HC and CO emissions
4. The engine design has been shown to demonstrate well in a mobile platform.

Further refinements are being made to improve its power-to-weight ratio, to turn it into an attractive engine package for many applications, namely in the non-automotive sectors.

6. Acknowledgements

The financial grant extended by the Malaysian Ministry of Science, Technology & Innovation (MOSTI, grant no.:03-02-0000PR0005/03) and the assistance from all parties are gratefully acknowledged.

7. References

- [1] S.Scott Goldsborough and P. Van Blaringan, “ Optimizing the Scavenging System for a Two-Stroke Cycle, Free Piston Engine for High Efficiency and Low Emissions: A Computational Approach” SAE Paper No.: 2003-01-0001, 2003.
- [2] Patent Number 4,522,163, United State Patent, 11th. June 1985.