

**AN INTELLIGENT DECISION SUPPORT SYSTEM FOR MACHINE TOOL
SELECTION**

By
EMRAH ÇİMREN

Submitted to the Graduate School of Engineering and Natural Sciences
In partial fulfillment of
the requirements for the degree of
Master of Science

SABANCI UNIVERSITY

July 2004

**AN INTELLIGENT DECISION SUPPORT SYSTEM FOR MACHINE TOOL
SELECTION**

APPROVED BY:

Assistant Prof. Dr. Bülent Çatay
(Thesis Supervisor)

Associate Prof. Dr. Erhan Budak
(Thesis Supervisor)

Assistant Prof. Dr. Gürdal Ertek

Assistant Prof. Dr. Hüsnü Yenigün

Assistant Prof. Dr. Kerem Bülbül

DATE OF APPROVAL:

ACKNOWLEDGMENTS

I would like to express my deepest appreciation to my advisors, Associate Prof. Dr. Erhan Budak and Assistant Prof. Dr. Bülent Çatay, for the guidance, encouragement, and feedback they provided me during the thesis process.

Abstract

The selection of appropriate machines and equipments is one of the most critical decisions in the design and development of a successful production environment. Considering the detailed specifications related to the functional requirements, productivity, quality, flexibility, cost, etc., and the number of available alternative machine tools in the market, the selection procedure can be quite complicated and time consuming.

In this thesis, a user-friendly decision support system called Intelligent Machine Tool Selection is developed for machine tool selection. The software guides decision-maker in selecting available machines via effective algorithms: Analytic Hierarchy Process (AHP). It has some special features which may not be included in other decision support systems. The user does not need to have detailed technical knowledge as he is guided by simple questions throughout the selection process. The user first determines the relevant criteria to be considered (such as productivity, flexibility, etc.) and then makes a pair-wise comparison of each criterion to the others. There are many sub-criteria such as machine power, spindle speed, tool magazine capacity, etc. which are used to determine the scores for each criterion. If desired, some important requirements for an application, such as power and force, can be determined using process models which are also integrated to the software. The software can store the relevant new information associated with the user so that it can be made available to facilitate the successive decision-making processes. After a list of machines with their specifications is retrieved from the database based upon the user specified requirements, the selected criteria are considered in the AHP process. The application of the system is presented through several examples.

Furthermore, sensitivity analysis is used to determine the most critical criterion and the most critical measure of performance. Cost analysis is carried out for the purchasing decision of a selected machine tool and its additional options. Reliability and precision analysis guide decision-maker selection of suitable machines.

Özet

Uygun tezgahların seçilmesi verimli bir üretim ortamının tasarımı ve geliştirilmesinde verilmesi gereken önemli kararlardan biridir. Makinelerin fonksiyonel gereklilikleri, üretkenlikleri, kalitesi, esneklikleri, maliyeti, pazarda satışa sunulan uygun makine alternatifleri vs. gibi kısıtlara bakıldığında makine seçim problemi karmaşık ve çözümü için zaman gerektiren bir hal alır.

Bu çalışmada takım tezgahi seçiminde kullanılan, kullanıcı uyumlu bir karar destek sistemi geliştirilmiştir. Gelistirilen yazılım, Analytic Hierarchy Process (AHP) yöntemini kullanarak, karar vericiye edeki makine alternatifleri arasından uygun makineleri seçmesi için yol gösterir. Yazılım diğer karar sistemlerinden farklı olarak bazı özelliklere sahiptir. Bunlardan en önemlisi, seçim aşamasının sadece basit sorulardan oluşması nedeniyle, kullanıcının makine teknik bilgisine sahip olmasa bile karar verme işlemini gerçekleştirebilmesini sağlamasıdır. Takım tezgahi seçim süreci esnasında ilk olarak istenilen tezgahta bulunması gereken ana kriterler (üretkenlik, esneklik vs.) tanımlanır. Daha sonra bu ana kriterler aralarında karşılaştırılır. Bu ana kriterlere bağlı olan güç, takım magazin kapasitesi, tezgah boyutları gibi alt kriterlerde, seçilen ana kriterlerin önemini belirlemek için kendi aralarında kıyaslanırlar. Eğer istenirse yazılıma sonradan entegre edilecek modeller ile seçim işlemi için gerekli olabilecek tezgah güç ve kuvvet bilgilerinin hesaplanabilir. Karar destek sistemi yazılımı kullanıcıyla ilgili her türlü bilgiyi saklama ve kullanıcının bir sonraki seçim işlemlerinde bunları kullanabilmesine olanak verme özelliğine sahiptir. Aralarında seçim yapılacak takım tezgahi alternatifleri yazılım veri tabanında saklanır ve karar verici tarafından belirlenen özelliklere ve AHP işlemi sonucuna göre uygun tezgahlar buradan çağırılır.

Ayrıca, duyarlılık analizi yardımı ile takım tezgahi seçim aşamasında seçilen kriterlerden en önemlisi belirlenebilir. Maliyet analizi ile alternatif tezgahların ve buna ilave edilebilecek tezgah özelliklerinin ekonomik karşılaştırmaları yapılır. Güvenilirlik ve kesinlik analizleri de karar vericinin alternatifleri güvenilirlik ve kesinlik değerlerine göre incelemesine olanak verir.

TABLE OF CONTENTS

1.	INTRODUCTION	1
2.	BACKGROUND	3
	2.1. Review on Decision-Making for Machine Selection Literature	3
	2.2. Multi-Criteria Decision-Making	6
	2.2.1. The Weighted Sum Model Method.....	9
	2.2.2. The Weighted Product Model Method.....	9
	2.2.3. Analytic Hierarchy Process	10
	2.2.3.1. Structuring a Decision Problem.....	11
	2.2.3.2. The Philosophy of the Analytic Hierarchy Process.....	11
	2.2.4. Revised AHP	16
	2.3. Sensitivity Analysis	16
	2.4. Cost Analysis	17
	2.4.1 Cost Evaluation Methods	17
	2.4.1.1. The Present Worth Method.....	17
	2.4.1.2. The Future Worth Method	18
	2.4.1.3. The Annual Worth Method.....	18
	2.4.2. The Analysis Period	19
	2.4.3. Decision-Making When Useful Lives are Different among The Alternatives	19
	2.5. Machine Precision and Reliability	20
	2.5.1. Precision	20
	2.5.2. Reliability	21
	2.6. Application Environment	22
	2.6.1. Implementation Tool.....	22
	2.6.2. Database	22

2.6.3. Database Management	24
2.7 Summary.....	24
3. DECISION METHODOLOGY	26
3.1. Decision Criteria and Machine Specifications	26
3.1.1. Decision Criteria	26
3.1.2. Classification of Machines (Database Structure).....	27
3.2. The Analytic Hierarchy Process	32
3.3. Selecting the Best Machine.....	37
3.3.1. Eliminating Alternatives	37
3.3.2. Applying Scores on the Alternatives	37
3.3.3. Cost Analysis	39
3.3.4. Reliability Analysis	40
3.3.5. Precision Analysis	41
3.3.6. Final Selection.....	42
3.4. Sensitivity Analysis	43
3.5. Summary.....	44
4. IMPLEMENTATION.....	45
4.1. Software.....	45
4.2. Summary.....	62
5. CONCLUSION.....	63
REFERENCE LIST	65

LIST OF TABLES

Table 2.1 Scale Of Relative Importance (Triantaphyllou [14]).....	13
Table 2.2 Data For Cost Analysis	20
Table 3.1 Simple Criteria	27
Table 3.2 Detailed Criteria.....	27
Table 3.3 Simple Machining Center Specifications	28
Table 3.4 Detailed Machining Center Specifications	29
Table 3.5 Sub-Criteria Comparisons For Productivity	33
Table 3.6 Sub-Criteria Comparison Values For Productivity	33
Table 3.7 Sub-Criteria Normalized Comparison Values For Productivity.....	34
Table 3.8 Relative Weights For Productivity	34
Table 3.9 Sub-Criteria Comparisons For Flexibility	34
Table 3.10 Sub-Criteria Normalized Comparison Values For Flexibility	35
Table 3.11 Relative Weights For Flexibility.....	35
Table 3.12 Main Criteria Comparisons.....	35
Table 3.13 Main Criteria Normalized Comparison Values	36
Table 3.14 Main Criteria Comparison Values	36
Table 3.15 Main Criteria Comparison Values	36
Table 3.16 Machine Alternatives	37
Table 3.17 Normalized Machine Alternative Values.....	38
Table 3.18 Machine Alternatives	38
Table 3.19 Machine Ranking As A Result Of Ahp	39
Table 3.20 Cost Values For Machines	40
Table 3.21 Machine Ranking As A Result Of Cost Analysis.....	40
Table 3.22 Reliability Analysis Comparisons	40
Table 3.23 Machine Reliability Values.....	41
Table 3.24 Machine Ranking As A Result Of Reliability Analysis	41
Table 3.25 Comparisons For Precision Analysis	41
Table 3.26 Precision Values Of Machine Alternatives.....	42
Table 3.27 Machine Ranking As A Result Of Precision Analysis	42
Table 3.28 Rankings For Machine Alternatives	42
Table 3.29 Comparisons For Sensitivity Analysis.....	43
Table 3.30 New Machine Ranking As A Result Of Sensitivity Analysis	44

LIST OF FIGURES

Figure 2.1 A Taxonomy Of Mcdm Methods (Triantaphyllou [15])	7
Figure 2.2 A Typical Decision Matrix	8
Figure 2.3 A Three Level Hierarchy (Saaty [10]).....	12
Figure 2.4 A Pairwise Comparison Matrix	13
Figure 2.5 A Consistent Pair-Wise Comparison Matrix	14
Figure 3.1 Machine Spindle	28
Figure 3.2 Machining Center	30
Figure 3.3 Three Axis Machining Center	30
Figure 3.4 Three Axis Horizontal Machining Center (3 Linear Axes).....	31
Figure 3.5 Four Axis Machining Center (3 Linear And 1 Rotary Axes).....	31
Figure 3.6 Five Axis Machining Center (3 Linear And 2 Rotary Axes)	32
Figure 3.7 Machine Rankings	43
Figure 4.1 Machine Selection Screen.....	46
Figure 4.2 Machine Selection Second Step Screen (Database Search)	47
Figure 4.3 Machine Selection 2nd Step Screen (Guiding)	47
Figure 4.4 Machine Selection 2nd Step Screen (Guiding2)	48
Figure 4.5 Machine Selection 3rd Step Screen.....	49
Figure 4.6 Machine Selection 4th Step Screen	49
Figure 4.7 Machine Selection 5th Step Screen (Ahp)	50
Figure 4.8 Machine Selection 6th Step Screen (Ahp)	51
Figure 4.9 Machine Selection 7th Step Screen (Ahp)	51
Figure 4.10 Machine Selection 8th Step Screen (Ahp).....	52
Figure 4.11 Machine Selection Results	52
Figure 4.12 Machine Selection Results Properties	53
Figure 4.13 Reliability Analysis Part 1 And 2.....	54
Figure 4.14 Reliability Analysis Part 3.....	54
Figure 4.15 Reliability Analysis Part 4.....	55
Figure 4.16 Precision Analysis Part 1.....	55
Figure 4.17 Precision Analysis Part 2.....	56
Figure 4.18 Precision Analysis Part 3.....	56

Figure 4.19 Precision Analysis Part 4.....	57
Figure 4.20 Cost Analysis Part 1	57
Figure 4.21 Cost Analysis Part 2	58
Figure 4.22 Cost Analysis Part 3	58
Figure 4.23 Report	59
Figure 4.24 Sensitivity Analysis Part 1.....	59
Figure 4.25 Sensitivity Analysis Part 2.....	60
Figure 4.26 Sensitivity Analysis Part 3.....	61
Figure 4.27 Define A New Machine Manufacturer	61
Figure 4.28 Define A New Machine	62

**AN INTELLIGENT DECISION SUPPORT SYSTEM FOR MACHINE TOOL
SELECTION**

By
EMRAH ÇIMREN

Submitted to the Graduate School of Engineering and Natural Sciences
In partial fulfillment of
the requirements for the degree of
Master of Science

SABANCI UNIVERSITY

July 2004

**AN INTELLIGENT DECISION SUPPORT SYSTEM FOR MACHINE TOOL
SELECTION**

APPROVED BY:

Assistant Prof. Dr. Bülent Çatay
(Thesis Supervisor)

Associate Prof. Dr. Erhan Budak
(Thesis Supervisor)

Assistant Prof. Dr. Gürdal Ertek

Assistant Prof. Dr. Hüsnü Yenigün

Assistant Prof. Dr. Kerem Bülbül

DATE OF APPROVAL:

ACKNOWLEDGMENTS

I would like to express my deepest appreciation to my advisors, Associate Prof. Dr. Erhan Budak and Assistant Prof. Dr. Bülent Çatay, for the guidance, encouragement, and feedback they provided me during the thesis process.

Abstract

The selection of appropriate machines and equipments is one of the most critical decisions in the design and development of a successful production environment. Considering the detailed specifications related to the functional requirements, productivity, quality, flexibility, cost, etc., and the number of available alternative machine tools in the market, the selection procedure can be quite complicated and time consuming.

In this thesis, a user-friendly decision support system called Intelligent Machine Tool Selection is developed for machine tool selection. The software guides decision-maker in selecting available machines via effective algorithms: Analytic Hierarchy Process (AHP). It has some special features which may not be included in other decision support systems. The user does not need to have detailed technical knowledge as he is guided by simple questions throughout the selection process. The user first determines the relevant criteria to be considered (such as productivity, flexibility, etc.) and then makes a pair-wise comparison of each criterion to the others. There are many sub-criteria such as machine power, spindle speed, tool magazine capacity, etc. which are used to determine the scores for each criterion. If desired, some important requirements for an application, such as power and force, can be determined using process models which are also integrated to the software. The software can store the relevant new information associated with the user so that it can be made available to facilitate the successive decision-making processes. After a list of machines with their specifications is retrieved from the database based upon the user specified requirements, the selected criteria are considered in the AHP process. The application of the system is presented through several examples.

Furthermore, sensitivity analysis is used to determine the most critical criterion and the most critical measure of performance. Cost analysis is carried out for the purchasing decision of a selected machine tool and its additional options. Reliability and precision analysis guide decision-maker selection of suitable machines.

Özet

Uygun tezgahların seçilmesi verimli bir üretim ortamının tasarımı ve geliştirilmesinde verilmesi gereken önemli kararlardan biridir. Makinelerin fonksiyonel gereklilikleri, üretkenlikleri, kalitesi, esneklikleri, maliyeti, pazarda satışa sunulan uygun makine alternatifleri vs. gibi kısıtlara bakıldığında makine seçim problemi karmaşık ve çözümü için zaman gerektiren bir hal alır.

Bu çalışmada takım tezgahi seçiminde kullanılan, kullanıcı uyumlu bir karar destek sistemi geliştirilmiştir. Gelistirilen yazılım, Analytic Hierarchy Process (AHP) yöntemini kullanarak, karar vericiye edeki makine alternatifleri arasından uygun makineleri seçmesi için yol gösterir. Yazılım diğer karar sistemlerinden farklı olarak bazı özelliklere sahiptir. Bunlardan en önemlisi, seçim aşamasının sadece basit sorulardan oluşması nedeniyle, kullanıcının makine teknik bilgisine sahip olmasa bile karar verme işlemini gerçekleştirebilmesini sağlamasıdır. Takım tezgahi seçim süreci esnasında ilk olarak istenilen tezgahta bulunması gereken ana kriterler (üretkenlik, esneklik vs.) tanımlanır. Daha sonra bu ana kriterler aralarında karşılaştırılır. Bu ana kriterlere bağlı olan güç, takım magazin kapasitesi, tezgah boyutları gibi alt kriterlerde, seçilen ana kriterlerin önemini belirlemek için kendi aralarında kıyaslanırlar. Eğer istenirse yazılıma sonradan entegre edilecek modeller ile seçim işlemi için gerekli olabilecek tezgah güç ve kuvvet bilgilerinin hesaplanabilir. Karar destek sistemi yazılımı kullanıcıyla ilgili her türlü bilgiyi saklama ve kullanıcının bir sonraki seçim işlemlerinde bunları kullanabilmesine olanak verme özelliğine sahiptir. Aralarında seçim yapılacak takım tezgahi alternatifleri yazılım veri tabanında saklanır ve karar verici tarafından belirlenen özelliklere ve AHP işlemi sonucuna göre uygun tezgahlar buradan çağırılır.

Ayrıca, duyarlılık analizi yardımı ile takım tezgahi seçim aşamasında seçilen kriterlerden en önemlisi belirlenebilir. Maliyet analizi ile alternatif tezgahların ve buna ilave edilebilecek tezgah özelliklerinin ekonomik karşılaştırmaları yapılır. Güvenilirlik ve kesinlik analizleri de karar vericinin alternatifleri güvenilirlik ve kesinlik değerlerine göre incelemesine olanak verir.

TABLE OF CONTENTS

1.	INTRODUCTION	1
2.	BACKGROUND	3
2.1.	Review on Decision-Making for Machine Selection Literature	3
2.2.	Multi-Criteria Decision-Making	6
2.2.1.	The Weighted Sum Model Method.....	9
2.2.2.	The Weighted Product Model Method.....	9
2.2.3.	Analytic Hierarchy Process	10
2.2.3.1.	Structuring a Decision Problem.....	11
2.2.3.2.	The Philosophy of the Analytic Hierarchy Process.....	11
2.2.4.	Revised AHP	16
2.3.	Sensitivity Analysis	16
2.4.	Cost Analysis	17
2.4.1	Cost Evaluation Methods	17
2.4.1.1.	The Present Worth Method.....	17
2.4.1.2.	The Future Worth Method	18
2.4.1.3.	The Annual Worth Method.....	18
2.4.2.	The Analysis Period	19
2.4.3.	Decision-Making When Useful Lives are Different among The Alternatives	19
2.5.	Machine Precision and Reliability	20
2.5.1.	Precision	20
2.5.2.	Reliability	21
2.6.	Application Environment	22
2.6.1.	Implementation Tool.....	22
2.6.2.	Database	22

2.6.3. Database Management	24
2.7 Summary.....	24
3. DECISION METHODOLOGY	26
3.1. Decision Criteria and Machine Specifications	26
3.1.1. Decision Criteria	26
3.1.2. Classification of Machines (Database Structure).....	27
3.2. The Analytic Hierarchy Process	32
3.3. Selecting the Best Machine.....	37
3.3.1. Eliminating Alternatives	37
3.3.2. Applying Scores on the Alternatives	37
3.3.3. Cost Analysis	39
3.3.4. Reliability Analysis	40
3.3.5. Precision Analysis	41
3.3.6. Final Selection.....	42
3.4. Sensitivity Analysis	43
3.5. Summary.....	44
4. IMPLEMENTATION.....	45
4.1. Software.....	45
4.2. Summary.....	62
5. CONCLUSION.....	63
REFERENCE LIST	65

LIST OF TABLES

Table 2.1 Scale Of Relative Importance (Triantaphyllou [14]).....	13
Table 2.2 Data For Cost Analysis	20
Table 3.1 Simple Criteria	27
Table 3.2 Detailed Criteria.....	27
Table 3.3 Simple Machining Center Specifications	28
Table 3.4 Detailed Machining Center Specifications	29
Table 3.5 Sub-Criteria Comparisons For Productivity	33
Table 3.6 Sub-Criteria Comparison Values For Productivity	33
Table 3.7 Sub-Criteria Normalized Comparison Values For Productivity.....	34
Table 3.8 Relative Weights For Productivity	34
Table 3.9 Sub-Criteria Comparisons For Flexibility	34
Table 3.10 Sub-Criteria Normalized Comparison Values For Flexibility	35
Table 3.11 Relative Weights For Flexibility.....	35
Table 3.12 Main Criteria Comparisons.....	35
Table 3.13 Main Criteria Normalized Comparison Values	36
Table 3.14 Main Criteria Comparison Values	36
Table 3.15 Main Criteria Comparison Values	36
Table 3.16 Machine Alternatives	37
Table 3.17 Normalized Machine Alternative Values.....	38
Table 3.18 Machine Alternatives	38
Table 3.19 Machine Ranking As A Result Of Ahp	39
Table 3.20 Cost Values For Machines	40
Table 3.21 Machine Ranking As A Result Of Cost Analysis.....	40
Table 3.22 Reliability Analysis Comparisons	40
Table 3.23 Machine Reliability Values.....	41
Table 3.24 Machine Ranking As A Result Of Reliability Analysis	41
Table 3.25 Comparisons For Precision Analysis	41
Table 3.26 Precision Values Of Machine Alternatives.....	42
Table 3.27 Machine Ranking As A Result Of Precision Analysis	42
Table 3.28 Rankings For Machine Alternatives	42
Table 3.29 Comparisons For Sensitivity Analysis.....	43
Table 3.30 New Machine Ranking As A Result Of Sensitivity Analysis	44

LIST OF FIGURES

Figure 2.1 A Taxonomy Of Mcdm Methods (Triantaphyllou [15])	7
Figure 2.2 A Typical Decision Matrix	8
Figure 2.3 A Three Level Hierarchy (Saaty [10]).....	12
Figure 2.4 A Pairwise Comparison Matrix	13
Figure 2.5 A Consistent Pair-Wise Comparison Matrix	14
Figure 3.1 Machine Spindle	28
Figure 3.2 Machining Center	30
Figure 3.3 Three Axis Machining Center	30
Figure 3.4 Three Axis Horizontal Machining Center (3 Linear Axes).....	31
Figure 3.5 Four Axis Machining Center (3 Linear And 1 Rotary Axes).....	31
Figure 3.6 Five Axis Machining Center (3 Linear And 2 Rotary Axes)	32
Figure 3.7 Machine Rankings	43
Figure 4.1 Machine Selection Screen.....	46
Figure 4.2 Machine Selection Second Step Screen (Database Search)	47
Figure 4.3 Machine Selection 2nd Step Screen (Guiding)	47
Figure 4.4 Machine Selection 2nd Step Screen (Guiding2)	48
Figure 4.5 Machine Selection 3rd Step Screen.....	49
Figure 4.6 Machine Selection 4th Step Screen	49
Figure 4.7 Machine Selection 5th Step Screen (Ahp)	50
Figure 4.8 Machine Selection 6th Step Screen (Ahp)	51
Figure 4.9 Machine Selection 7th Step Screen (Ahp)	51
Figure 4.10 Machine Selection 8th Step Screen (Ahp).....	52
Figure 4.11 Machine Selection Results	52
Figure 4.12 Machine Selection Results Properties	53
Figure 4.13 Reliability Analysis Part 1 And 2.....	54
Figure 4.14 Reliability Analysis Part 3.....	54
Figure 4.15 Reliability Analysis Part 4.....	55
Figure 4.16 Precision Analysis Part 1.....	55
Figure 4.17 Precision Analysis Part 2.....	56
Figure 4.18 Precision Analysis Part 3.....	56

Figure 4.19 Precision Analysis Part 4.....	57
Figure 4.20 Cost Analysis Part 1	57
Figure 4.21 Cost Analysis Part 2	58
Figure 4.22 Cost Analysis Part 3	58
Figure 4.23 Report	59
Figure 4.24 Sensitivity Analysis Part 1.....	59
Figure 4.25 Sensitivity Analysis Part 2.....	60
Figure 4.26 Sensitivity Analysis Part 3.....	61
Figure 4.27 Define A New Machine Manufacturer	61
Figure 4.28 Define A New Machine	62

1. INTRODUCTION

Today's fierce market conditions force companies to make very careful decisions. Any waste of resources such as money, time, workforce, etc. due to wrong decisions directly increases companies' costs, which, in turn, is reflected to the customer. Also, improperly selected machines decrease the overall performance of a production system. Since the selection of new machines is a time consuming and difficult process requiring advanced knowledge and experience, it may cause several problems for engineers, managers, and for machine manufacturers. If the customer selects the machines which are not suitable for the manufacturing environment, she will need to change the factory layout even if it is costly. If a machine tool with excess capacity is selected, it will increase initial investment and cause low utilization. However, if a machine tool has less capacity, the company will be faced with unsatisfied demand. If the customer would like to increase manufacturing level, quality, and product type in the future and selects less flexible machine tools, it will cause several problems such as decreasing competition power in the market. The lack of a standard format in machine catalogues, the large number of factors to be considered, and continuous introduction of new machine tools together with the advancements in the technology complicate the problem further. Proper and effective machine selection needs to analyze a large amount of data and consider many factors. Therefore, machine database should be large and selection criteria should be well defined. In decision-making problems for machine selection, the decision-maker should be an expert or at least be very familiar with the machine properties to select the most suitable machine among the alternatives.

Most of the companies are not aware of the academic work in selecting the new technology. This clearly indicates need for a simplified and practical approach for the machine selection process.

Decision support systems (DSS) aim at helping decision-makers in making accurate decisions. DSS are interactive computer-based systems for solving decision-making problems using data, applying, heuristics or decision-making methods, and building a model using a combination of methods and data.

Multi-criteria decision-making methods such as weighted sum, weighted product, AHP, and revised AHP are reviewed for the machine selection problem. These approaches may be used in different decision-making problems and have different performance. For example, for machine tool selection problem, in order to use weighted sum decision-making method, decision-maker should be experienced about machine properties to assign proper weights. In this study, AHP is used as the decision-making method since it only depends on simple qualitative pair-wise comparisons.

The selection process consists of five steps. In the first step, decision-maker decides on machine specifications such as machine type, horse power, cutting feed, etc. and eliminates machines that do not meet these specifications. The type of the necessary machine directly depends on the part that will be manufactured. Considering the product, the decision-maker defines manufacturing process and machine properties in this step. In the second step, the decision-maker determines main and sub-criteria. Then, she makes pair-wise comparisons between these main and sub-criteria by assigning qualitative values. These values may differ from one company to another and for a variety of production environment. In the third step, AHP is performed to determine the best machine, and machines are ranked from best to worst. After obtaining the machines that best satisfy the user requirements, in the fourth step, cost, precision and reliability analyses are applied in order to re-evaluate the machines with higher score. In the fifth step, sensitivity analysis is performed. The sensitivity analysis determines the smallest change in current weights of the criteria which can alter the existing ranking of the alternatives. Sensitivity analysis is also applied for the determination of the most critical measure of performance. As a result of selection methodology, decision-maker has four different machine rankings and selects machine(s) based on these rankings.

A DSS is implemented using the selection methodology that described above.

2. BACKGROUND

This chapter presents the background information that is necessary to understand the machine selection problem. First, the decision-making literature for machine selection is reviewed. Second, the AHP is addressed. Third, sensitivity analysis is presented with examples. Fourth, cost analysis is examined by using engineering economics tools. Last, tools and knowledge that are necessary for the application environment are presented.

2.1. Review on Decision-Making for Machine Selection Literature

A decision is a choice made from two or more alternatives. Decision-making is the process of sufficiently reducing uncertainty and doubt about alternatives to allow a reasonable choice to be made among them. Researchers have addressed a variety of decision-making problems by using different decision-making methods.

The literature review has revealed that most of the work in machine selection deals with flexible manufacturing systems (FMS). AHP, fuzzy multiple-attribute decision-making models, linear and 0-1 integer programming models and genetic algorithms are used to develop a decision models to make selection in FMS environment.

Two main works are found in literature as examples of the AHP approach. Yang et al [8] study machine selection by the AHP method which is concerned with the development of a model using the AHP for the selection of the most suitable machine from a range of machines available for the manufacture of particular part types. In this study, there are four main criteria: machine procedures, lead time, labor cost, and operation shift; and three alternatives: conventional machines, NC machines and

flexible manufacturing cells. Tabucanon et al. [12] develop a decision support framework designed to aid decision-makers in selecting the most appropriate machines for FMS. The framework can be used in the pre-investment stage of the planning process, after a decision has been made, in principle, to build an FMS. The framework mainly consists of two parts. The first part is called the pre-screening stage, which narrows down all possible configurations by using the AHP. The second part uses a goal programming (GP) model to find out the satisfactory candidate from the remaining short-listed configuration. After applying the GP model, AHP is used again for sensitivity analysis. This approach helps managers explore and evaluate costs and benefits of various scenarios for each configuration separately by experimenting with different types of machines and degrees of flexibility of the system. Tabucanon et al. [12] propose an approach for the design and development of an intelligent DSS that is intended to help the selection process of alternative machines for FMS. The process consists of a series of steps starting with an analysis of the information and culminating in a conclusion —a selection from several available alternatives and verification of the selected alternative to solve the problem. The approach presented combines the AHP technique for multi-criteria decision-making with the rule-based technique for creating Expert Systems (ES). Such an approach allows the past experience, expressed as heuristics in ES, to be used. Moreover, this approach determines the architecture of the computer-based environment necessary for the decision support software system to be created. It helps the user to find the best machine on the basis of several objectives as well as subjective attributes. Oeltjenbruns et al [6] investigate the compatibility of AHP to strategic planning in manufacturing. The objective is to develop/explore different planning alternatives ranging from extending the life of existing machinery to total replacement with a new manufacturing system and to evaluate these alternatives through economical and technological criteria. Yurdakul [17] presents a model which links machine alternatives to manufacturing strategy for machine tool selection. In this study, the evaluation of investment in machine tools can model and quantify strategic considerations by using the AHP method. On the other hand, Cheng and Li [5] claim that although AHP is an effective tool for management decision-making, it can be defective if used improperly.

Wang et al. [16] suggest a fuzzy multiple-attribute decision-making model to assist the decision-maker in dealing with the machine selection problem for FMS. In implementing an FMS, decision-makers encounter the machine selection problem

which includes attributes, e.g. machine type, cost, and number of machines, floor space and planned expenditures. In addition, the membership functions of weights for those attributes are determined in accordance with their distinguishable ability and robustness when the ranking is performed.

A linear 0-1 integer programming model for machine tool assignment and operation allocation in FMS is proposed by Atmani and Lashkari [3]. The model determines the optimal machine-tool combinations, and assigns the operations of the part types to the machines (minimizing total costs of processing, material handling, and machine setups). It is assumed that there is a set of machines with known processing capabilities. Tool magazine capacity, tool life, and machine capacity constraints are considered.

Moon et al. [9] propose a model for an integrated machine tool selection and sequencing. The model which is formulated as a 0-1 integer programming determines machine visiting sequences for all part types such that the total production time for the production order is minimized and workloads among machine tools are balanced. To solve the model, GA approach based on a topological sort technique is developed. To demonstrate the efficiency of the proposed GA approach on the integrated machine tool selection and sequencing problem, a number of numerical experiments using various problem sizes are carried out. The numerical experiments show that the proposed GA approach is efficient for these problems.

Subramaniam et al. [11] propose a study which deals with the selection of machines in a job shop. In this work, it is stated that job shops, being equipped with multi-purpose machining centers, require versatile scheduling strategies to account for multiple job routes. They present machine selection rules in a dynamic job shop. With the increasing use of multi-purpose machining centers in job shops, the scheduling problem can no longer neglect multiple job routes. Existing scheduling approaches seldom address flexibility in job routes and the aim of this work is to demonstrate that significant improvements to the scheduling performance of dispatching rules can be achieved easily through the use of simple machine selection rules. Three such rules are proposed and their effectiveness is evaluated through a simulation study of a dynamic job shop. In addition, three dynamic conditions, namely the tightness of due dates, the flexibility of the job routes, and the reliability of the machines, are varied to ensure that the simulation is performed for significantly different job shop conditions. The results

of the simulation study indicate that improvements to the performance of simple dispatching rules are significantly enhanced when used with machine selection rules.

Haddock et al. [7] a DSS that assists in the specific selection of a machine that is required to process specific dimensions of a part. The selection will depend on part characteristics, which are labeled in a part code and correlated with machine specifications and qualifications. The choice of the optimal machine, vs. possible alternates, can be made by a planner comparing a criterion measure (or measures). Examples of possible criteria are the relative location of machines, machining cost, processing time, and availability of a machine (or machines).

2.2. Multi-Criteria Decision-Making

Multiple-criteria decision-making (MCDM) refers to making decisions in the presence of multiple, usually conflicting, criteria. MCDM problems are common in everyday life. In personal context, a house or a car one buys may be characterized in terms of price, size, style, safety, comfort, etc. In a manufacturing environment, selecting appropriate machines, vendor, employee or production time may be considered as examples.

The basic idea behind MCDM is the construction of a decision tree using a selection of criteria relevant to a particular decision and the weighting/scoring of the criteria and the alternatives for each different criterion.

MCDM is well-known branch of decision-making. According to Triantaphyllou [15] it is divided into multi-objective decision-making (MODM) and multi-attribute decision-making (MADM). MODM studies decision problems in which decision space is continuous. A typical example is mathematical programming problems such as “the vector maximum” problem which is attributed to Kuhn and Tucker with multiple objective functions. On the other hand, MADM concentrates on problems with discrete decision spaces in which the set of decision alternatives are predetermined. Very often the terms MADM and MCDM are used to mean the same class of models (i.e., MCDM)

There are many MCDM methods in the literature having its own characteristics. They can be classified in many ways such as the type of data used, the number of decision-makers involved in the decision process and the type of information.

MCDM methods can be classified as deterministic, stochastic or fuzzy according to the data type they use. Another classification may be made, according to the number

of decision makers involved in the decision process: single decision-maker and group decision makers (Triantaphyllou [14]).

Triantaphyllou [15] give the taxonomy of MCDM methods according to the type of information (Figure 2.1). First, methods are classified according to the type of information. Then, they are grouped according to the importance of information.

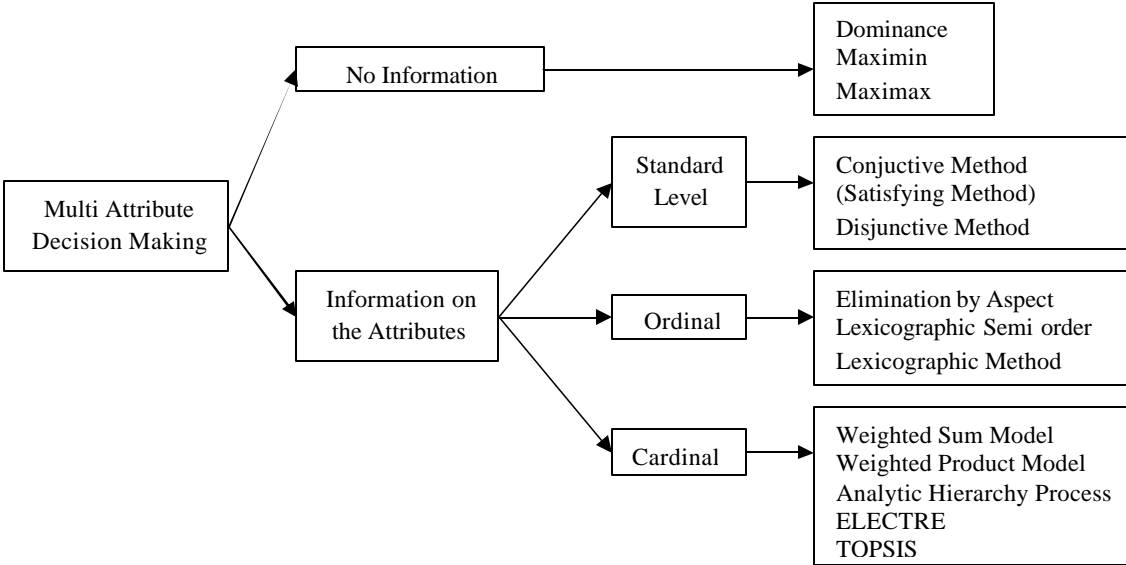

Figure 2.1 A Taxonomy of MCDM Methods (Triantaphyllou [15])

Each of the methods uses numeric techniques to help decision-makers choose among a discrete set of alternative decisions. Choosing the best MCDM method is the first step of the decision-making problem. In Triantaphyllou [14] two criteria are developed and used for evaluating some MCDM methods. The first evaluative criterion is that an MCDM method that is accurate in multi-dimensional problems should also be accurate in single-dimensional problems. The second evaluative criterion is that an effective MCDM method should not change the indication of the best alternative when an alternative (not the best) is replaced by a worse alternative (given that the relative importance of each decision criterion remains unchanged).

Traditional decision-making models are focused on values, attributes, goals, and alternatives and they are subjective. Unlike the decision-making models, MCDM is composed of the objectively defined set of alternatives and subjectively defined criteria. The criteria are independent of alternatives. In the decision-making process, the most challenging work is to clarify and further construct the criteria that are close to the alternatives. In essence, the criteria and alternatives have different characteristics.

Conceptually, the alternatives are determined by the criteria. However, the criteria are generally abstract and conceptual, and the alternatives are tangible in most of the cases. The attributes, determined by the decision context and the decision-maker's preference, are constructed in hierarchy to fill in the gap between the criteria and the alternatives. Part of the decision-making process is choosing the attributes. The chosen attributes should reflect both the measurable components of the alternatives and the decision-maker's subjective criteria.

There are six concepts that are related with MCDM. Alternatives usually represent the different choices of action available to the decision-maker. MCDM problem deals with multiple attributes, which are referred to as goals or decision criteria. In some cases, if the number of criteria is large, they can be arranged in hierarchical manner in which major criteria may be associated with several sub-criteria. Conflict among criteria occurs (i.e. cost may conflict profit) when different criteria represent different dimensions of the alternatives. Different criteria may be associated with different units of measure. This is called incommensurable units. Most of MCDM methods require weights of importance which are usually normalized to add up to one. Decision matrix is used to express an MCDM problem (Triantaphyllou [15]).

A decision matrix, A , is an $m \times n$ matrix (m alternatives and n decision criteria) in which element a_{ij} (for $i=1,2,\dots,m$ and $j=1,2,\dots,n$) indicates the performance of alternative A_i when it is evaluated in terms of decision criterion C_j . It is also assumed that the decision-maker has determined the weights of relative performance of the decision criteria (denoted as w_j).

		Criteria				
		C₁	C₂	C₃	...	C_n
Alts.		(w_1)	w_2	w_3	...	w_n)
A_1		a_{11}	a_{12}	a_{13}	...	a_{1n}
A_2		a_{21}	a_{22}	a_{23}	...	a_{2n}
.	
.	
.	
A_m		a_{m1}	a_{m2}	a_{m3}	...	a_{mn}

Figure 2.2 A Typical Decision Matrix

Three steps can be followed in utilizing any decision-making technique involving numerical analysis of alternatives:

- (i) Determine the relevant criteria and alternatives,
- (ii) Attach numerical measures to the relative importance of the criteria and to the impacts of the alternatives on these criteria,
- (iii) Process the numerical values to determine the ranking of each alternative.

Despite the criticism that multi-dimensional methods have received, some of them such as weighted sum model (WSM), the weighted product model (WPM), the AHP, revised AHP, ELECTRE and TOPSIS methods are widely used. In what follows is a brief overview of some of these methods.

2.2.1. The Weighted Sum Model Method

In single dimensional problems, the WSM is probably the most commonly used approach.

Suppose that there are m alternatives and n criteria. A_{WSM}^* which is the WSM score of the best alternative:

$$A_{WSM}^* = \max_i \sum_{j=1}^n a_{ij}w_j \quad \text{for } i = 1, 2, 3, \dots, m \quad (2.1)$$

In equation (2.1), a_{ij} is the actual value of the i^{th} alternative in terms of the j^{th} criterion, and w_j is the weight of importance of the j^{th} criterion. Additive utility assumption rules this model, i.e., the total value of each alternative are equal to the sum of the products. In single dimensional cases, WSM can be applied efficiently. However, when it is applied to multi-dimensional WSM problems, difficulty with this method emerges.

2.2.2. The Weighted Product Model Method

The WPM is very similar to the WSM. Multiplication is the main difference. In this method, ratios, which are raised to the power equivalent to the relative weight of the corresponding criterion, are set. Each alternative is compared with the others by multiplying a number of ratios. A_K and A_L , $R(A_K/A_L)$ should be calculated as follows in order to compare two alternatives:

$$R(A_K/A_L) = \prod_{j=1}^n (a_{Kj}/a_{Lj})^{w_j} \quad (2.2)$$

In a maximization problem, alternative A_K is more desirable than alternative A_L if $R(A_K/A_L)$ is greater than or equal to one.

WPM can be used in single and multi-dimensional MCDM. Instead of actual values this method can use relative ones. This option allows analyzing two alternatives which contain different values. (a_{Kj} is called relative value)

$$\frac{a_{Kj}}{a_{Lj}} \geq \frac{\frac{a_{Kj}}{\sum_{i=1}^n a_{Ki}}}{\frac{a_{Lj}}{\sum_{i=1}^n a_{Li}}} \geq \frac{a_{Kj}}{a_{Lj}} \quad (2.3)$$

An alternative approach with the WPM method is to use only products without ratios, that is:

$$P(A_K) \geq \sum_{j=1}^n (a_{Kj})^{w_j} \quad (2.4)$$

$P(A_K)$ denotes the performance value (not a relative value) of alternative A_K when all the criteria are considered under the WPM model.

2.2.3. Analytic Hierarchy Process

Hierarchy is the ordering of parts or elements of a whole from the highest to the lowest. It is the principle of control that secures the effective functioning of the organization (Saaty [10]).

The general thought is “apples and oranges can’t be compared.” Is this true? Consider a hungry person who likes apples and oranges. She can choose between a large, red, pungent, and juicy looking Amasya apple and larger, old, and pale colored orange. Which one is chosen? The apple or orange that yields, according to preferences, the greater value across all the various attributes will be selected. She uses her experiences that identify properties and establish selection criteria for apples and oranges to make tradeoffs among the properties and reach a decision.

The AHP is a multi-criteria decision-making approach first introduced by Saaty. It is a basic approach to decision-making where the decision-maker carries out simple

pair-wise comparison judgments, which are then used to develop overall priorities for ranking the alternatives.

Saaty developed AHP in early 1970s in response to the scarce resources allocation and planning needs for the military. It involves the establishment of a framework that consists of groups of elements for rating and the use of a tailor-made questionnaire to collect the perceptions from experts or decision-makers on those groups of elements (Cheng and Li [5]).

AHP has several benefits. First, it helps to decompose an unstructured problem into a rational decision hierarchy (similar to decision tree). Second, it can elicit more information from the experts or decision-makers by employing pair-wise comparison of individual groups of elements. Third, it sets the computations to assign weights to the elements. Fourth, it uses the consistency measure to validate consistency of the rating from the experts and decision-makers. Therefore, it is argued to be composed of both qualitative and quantitative substances.

2.2.3.1. Structuring a Decision Problem

In making decisions, deciding what factors to be included in the hierarchic structure is the most important task. When constructing hierarchies one must include enough relevant detail to represent the problem. Considering the environment surrounding the problem, identifying the issues or attributes that one field should contribute to the solution are all-important issues when constructing hierarchy.

The elements being compared should be homogeneous. The hierarchy does not need to be complete when an element in a given level does not have to function as criterion for all the elements in the level below. Thus, a hierarchy can be divided into sub-hierarchies sharing only a common topmost element.

2.2.3.2. The Philosophy of the Analytic Hierarchy Process

The AHP is a general theory of measurement that is used to derive ratio scales from paired comparisons from multi-level hierarchic structures. These comparisons reflect the relative strength of preferences and feelings. In the general form of AHP, several factors are taken into consideration simultaneously.

In practice, AHP has two basic applications (Cheng and Li [5]). First, its traditional use is to assign weights to a set of predetermined elements (e.g. criteria,

factors) and make a decision out of several scenarios or alternatives. For example, it can assign weights to several criteria.

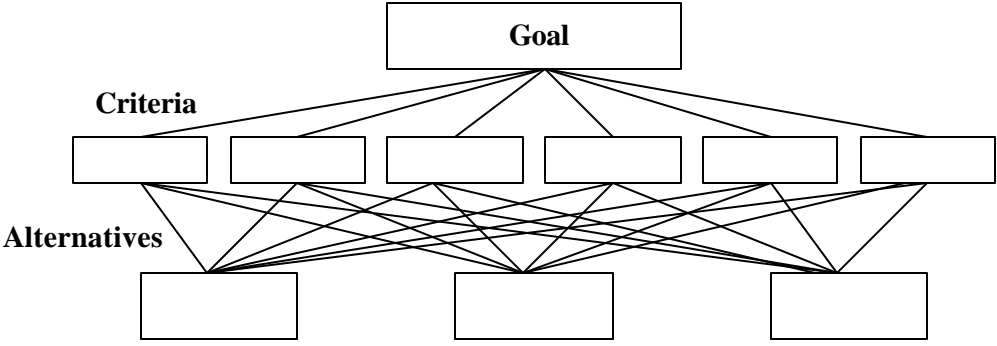

Figure 2.3 A Three Level Hierarchy (Saaty [10])

Then the assessors can give each candidate the scores to the weighted criteria and choose the one with the highest total score. Second, it can help to prioritize (rank) elements in order to identify the key elements. This application is useful for organizations in determining the allocation of resources. When an organization works on several projects simultaneously, ranking the relative importance level of individual tasks may help better allocate the resources in order to minimize the costs for storage, extra transportation, and risks of out-of-stock and stoppage.

In general, AHP has five major steps described as follows:

Step 1: Define the unstructured problem to decide AHP to be the appropriate method for solving the problem.

Step 2: Decompose the problem into a systematic hierarchical structure. This hierarchical structure attempts at decomposing an unstructured problem into several integrated dimensions (or components or elements). The problem itself is called the first level (sometimes it is called the zero level), while the first decomposed level is called the second level (when the problem is the zero level, the first decomposed level will be the first level). Each of these second-level dimensions may be decomposed into another set of elements and so on until no further decomposition is needed. That means further decompositions will generate the third level, the fourth level, and so on.

Step 3: Employ the pair-wise comparison method. Each group on the hierarchy will form a matrix. For example, if the group has five elements, it forms a 5 x 5 matrix. People (usually the decision-makers or experts) will compare each of the paired

elements in the matrices that form the questionnaire. Saaty [10] recommended the use of a nine-point scale.

Table 2.1 Scale of Relative Importance (Triantaphyllou [14])

Intensity of Importance	Definition	Explanation
1	Equal Importance	Two activities contribute equally
3	Weak Importance of one over another	Experience & Judgment slightly favor one over another
5	Essential or Strong Importance	...Strongly favor one over another
7	Very Strong and Demonstrated	...Strongly favored and its dominance demonstrated in practice
9	Absolute Importance	Evidence favoring one over another is of the highest possible order
2,4,6,8	Intermediate values between adjacent scale values	

The decision-maker carries out pair-wise comparisons in a nine-point scale then these comparisons are used to develop overall priorities for ranking the alternatives.

Let i and j be objectives. The relative importance of these objectives can be scored on a 9-point interval valued scale using Table 2.1. A value of 8 means that i is about eight times more important than j , or is midway between very strongly and absolutely more important than j .

Let $O_1, \dots, O_n, n \geq 2$, be the objectives. A pair-wise comparison matrix is an $n \times n$ matrix A with elements a_{ij} , indicating the importance value of objective i relative to objective j (Figure 2.4):

	O₁	...	O_j	...	O_n
O₁	a_{11}	...	a_{1j}	...	a_{1n}
.
.
.	.	a_{ii}	a_{ij}	a_{ik}	.
O_j	a_{j1}	a_{ii}	a_{ij}	a_{ik}	a_{in}
.
.
O_n	a_{n1}	.	a_{nj}	.	a_{nn}

Figure 2.4 A Pairwise Comparison Matrix

A pair-wise comparison matrix is consistent if and only if for all $i, j, k \in \{1, 2, \dots, n\}$:

- $a_{ii} = 1$
- $a_{ij} = 1/a_{ji}$
- $a_{ik} = a_{ij} \cdot a_{jk}$

Let A be a consistent pair-wise comparison matrix. Then A is as given in (Figure 2.5):

$$\begin{array}{c}
 \mathbf{O}_1 \\
 \mathbf{O}_2 \\
 \cdot \\
 \cdot \\
 \cdot \\
 \mathbf{O}_n
 \end{array}
 \begin{array}{c}
 \mathbf{O}_1 \quad \mathbf{O}_2 \quad \dots \quad \mathbf{O}_n \\
 \left| \begin{array}{cccc}
 \frac{w_1}{w_1} & \frac{w_1}{w_2} & \cdot & \frac{w_1}{w_n} \\
 \frac{w_2}{w_1} & \cdot & \cdot & \cdot \\
 \cdot & \cdot & \cdot & \cdot \\
 \cdot & \cdot & \cdot & \cdot \\
 \frac{w_n}{w_1} & \frac{w_n}{w_2} & \cdot & \frac{w_n}{w_n}
 \end{array} \right|
 \end{array}$$

Figure 2.5 A Consistent Pair-wise Comparison Matrix

$w_i \geq 0, i \in \{1, \dots, n\}$, denotes the weight of objective i . The weight vector $w = \{w_1, w_2, \dots, w_n\}$ for n objectives is obtained from A by finding a (non-trivial) solution to a set of n equations with n unknowns:

$$A \cdot w^T = n \cdot w^T \tag{2.5}$$

For convenience, weights are taken to sum up to 1, resulting in a unique non-trivial solution.

$$A^* w^T = \begin{array}{c}
 \frac{w_1}{w_1} \cdot w_1 + \frac{w_1}{w_2} \cdot w_2 + \dots + \frac{w_1}{w_n} \cdot w_n \\
 \cdot \quad \cdot \quad \cdot \quad \cdot \\
 \cdot \quad \cdot \quad \cdot \quad \cdot \\
 \cdot \quad \cdot \quad \cdot \quad \cdot \\
 \frac{w_n}{w_1} \cdot w_1 + \frac{w_n}{w_2} \cdot w_2 + \dots + \frac{w_n}{w_n} \cdot w_n
 \end{array}$$

$$= \begin{vmatrix} n.w_1 \\ n.w_2 \\ \cdot \\ \cdot \\ n.w_n \end{vmatrix} = n \cdot \begin{vmatrix} w_1 \\ w_2 \\ \cdot \\ \cdot \\ w_n \end{vmatrix} = n.w^T \quad (2.6)$$

In sum up the third step, suppose that there are n objectives in an AHP. An approximate weight vector is calculated as follows:

- Normalise each column j in A such that

$$\sum_i a_{ij} = 1$$

- Denote the resulting matrix by A' ;
- For each row i in A' , compute the average value

$$w_i = \frac{1}{n} \sum_j a'_{ij};$$

- w_i is the weight of objective i in the weight vector.

At the end of third step, the weights of objectives are determined.

Step 4: Carry out the consistency measure. Consistency measure is used to screen out the inconsistency of responses.

Consistency may be checked using the following procedure:

1. Compute $A.w^T$ by using equation (2.6)
2. Compute $\frac{1}{n} \sum_{i=1}^n \frac{A.w^T_{(i)}}{w^T_{(i)}}$ where $w^T_{(i)}$ is the i^{th} entry in w^T and $A.w^T_{(i)}$ is the i^{th} entry in $A.w^T$.
3. Compute the consistency index (CI)

$$CI = \frac{(\text{result from 2}) - n}{n - 1}$$

4. If $CI = 0$ then A is consistent;
 If $CI/RI_n \leq 0.1$ then A is consistent enough;
 If $CI/RI_n > 0.1$ then A is seriously inconsistent;

The Random index RI_n is the average value of CI for randomly chosen entries in A (provided that $a_{ii} = 1$ and $a_{ij} = 1/a_{ji}$, is given by:

n	2	3	4	5	6	7	...
RI_n	0	0.58	0.9	1.12	1.24	1.32	

Step 5: Use the relative weights for different purposes. For decision-making that involves a set of scenarios or alternatives, the weighted criteria will be scored by the decision-makers so that the total score can be calculated. For identifying key elements (e.g. critical factors of project success) in only one decomposed level, the elements with higher relative weights are more important.

2.2.4. Revised AHP

This method is proposed by Belton and Gear [4]. They demonstrated that a ranking inconsistency can occur when the AHP is used. Suppose that there are three alternatives ($A_i, i=1,2,3$) and three criteria. As a result of AHP suppose, three alternatives are ranked $A_2 > A_1 > A_3$. Next a new alternative, A_4 , which is the identical copy of A_2 , is introduced. Furthermore, it is also assumed that the relative weights of importance of the three criteria remain the same. For the new problem, as a result of AHP, the four alternatives are ranked as follows: $A_1 > A_2 = A_4 > A_3$. Belton and Gear claim that this result is in logical contradiction with the previous result (in which $A_2 > A_1$). When the revised AHP is applied on the new problem (that is, when the data are normalized by dividing the largest entry in each column), the desired solution is obtained ($A_2 = A_4 > A_1 > A_3$).

2.3. Sensitivity Analysis

The rate of change in the output of a model caused by the changes of the model inputs is estimated by sensitivity analysis methods. In decision-making problems, sensitivity analysis provides decision-maker to determine how critical each factor is. As a result of sensitivity analysis, “how sensitive is the actual ranking of the alternatives to the changes in the current weights of the decision criteria?” is answered.

There are two closely related sensitivity analysis problems. In the first problem, the sensitivity analysis approach determines what is the smallest change in current weights of the criteria, which can alter the existing ranking of the alternatives (is called *problem1*). In the second problem, it is determined how critical the performance

measures of the alternatives are in ranking of the alternatives (is called *problem2*). Triantaphyllou [15] discusses the solution methodologies for two problems.

2.4. Cost Analysis

Most engineering projects can be accomplished by more than one alternative. When the selection of these alternatives exclude the choice of any/others, the alternatives are called mutually exclusive. In general, the alternatives being considered require the investment of different amounts of capital, and their annual revenues and cost may vary. Sometimes the alternatives may have different useful lives. Because different levels of investment normally produce varying economic outcomes is performed an analysis to determine which one of the mutually exclusive alternatives is preferred and, consequently, how much capital should be invested.

In this part, cost analysis methods (analysis and comparison of feasible alternatives) are examined.

The problem of deciding which mutually exclusive alternative should be better if the following rule is adopted.

Rule: The alternative that requires the minimum investment of capital and produces satisfactory functional results will be chosen unless the incremental capital associated with an alternative having a larger investment can be justified with respect to its incremental benefits.

Under this rule, the acceptable alternative requiring the least investment capital is considering as the base alternative. The investment of additional capital over that required by the base alternative usually results in increased capacity, increased quality, increased revenues, decreased operating expenses, or increased life.

2.4.1 Cost Evaluation Methods

All engineering economy studies should consider the return that a given project or decision will or should produce. Three methods are described to analyze the cash flows which are used to determine economic advantages of an alternative.

2.4.1.1. The Present Worth Method

The present worth (PW) method is based on the concept of equivalent worth of all cash flows relative to some base or beginning point in time called as present. This method of an investment alternative is a measure of how much money an individual or a

firm could afford to pay for the investment in excess of its cost. It is assumed that the cash generated by the alternative is available for other uses that earn an interest of $i\%$.

$$PW(i\%) = F_0(1+i)^0 + F_1(1+i)^{-1} + F_2(1+i)^{-2} + \dots + F_k(1+i)^{-k} + \dots + F_N(1+i)^{-N} \\ = \sum_{k=0}^N F_k(1+i)^{-k} \quad (2.7)$$

Where i = effective interest rate
 k = index for each compounding period ($0 \leq k \leq N$),
 F_k = future cash flow at the end of period k , and
 N = number of compounding periods in the planning horizon (i.e. study period).

The higher the interest rate and is the further into the future a cash flow occurs the lower its PW is.

2.4.1.2. The Future Worth Method

The future worth (FW) is based on the equivalent worth of all cash inflows and outflows at the end of the planning horizon (study period) at an interest rate of $i\%$.

$$FW(i\%) = F_0(1+i)^N + F_1(1+i)^{N-1} + \dots + F_N(1+i)^0 = \sum_{k=0}^N F_k(1+i)^{N-k} \quad (2.8)$$

If $FW > 0$ for a project, it would be economically justified.

2.4.1.3. The Annual Worth Method

The annual worth (AW) of a project is an equal annual series of dollar amounts, for stated study period, that is equivalent to the cash inflows and outflows at an interest rate of $i\%$.

$$AW(i\%) = \underline{R} - \underline{E} - CR(i\%) \quad (2.9)$$

\underline{R} = annual equivalent revenues or savings,
 \underline{E} = annual equivalent expenses,
 CR = the capital recovery.

As long as the AW is greater than or equal to zero, the project is economically attractive; otherwise, it is not.

A project is the equivalent uniform annual cost of the capital invested which covers the two items, loss in value of the asset and interest on invested capital.

$$CR(i\%) = I(A/P, i\%, N) + S(A/F, i\%, N) \quad (2.10)$$

where, I = initial investment for project

S = salvage market value at end of study period

N = project study

The economic analysis of the mutually exclusive alternatives for an engineering project must be done on a comparable basis. Since each alternative meets the same functional requirements established for the project and some differences in performance capabilities, useful lives, output quality, or other factors still exist among them, the economic impacts of these differences must be included in the cash flow estimates and the analysis method (Sullivan [12]).

2.4.2. The Analysis Period

The study (analysis) period, also called as planning horizon, is the selected time period over which mutually exclusive alternatives are compared. The determination of the study period for a decision situation may be influenced by several factors such as service period required, the useful life, company policy, and so on. The key point is that the selected study period must be appropriate for the decision situation under investigation. Useful lives can be same for all alternatives or can be different. Unequal lives among alternatives somewhat complicate their analysis and comparison.

2.4.3. Decision-Making When Useful Lives are Different among The Alternatives

When the useful lives of mutually exclusive alternatives are different, it is assumed that the economic estimates for an alternative's initial useful life cycle will be repeated in all subsequent replacement cycles (repeatability assumption).

If the repeatability assumption is not applicable to a decision situation, then an appropriate study period needs to be selected (coterminated assumption). If this is the case, cash flow adjustments based on additional assumptions need to be used so that all alternatives are compared over the same study period.

Suppose that the data in Table 2.2 have been estimated for two mutually exclusive investment alternatives, *A* and *B*, associated with a small engineering project for which revenues as well as expenses are involved. They have useful lives of four and six years, respectively. Assume $i = 10\%$ per year.

Table 2.2 Data for Cost Analysis

	A	B
Capital Investment	-\$3,500	-\$5,000
Annual Revenue	1,900	2,500
Annual Expense	-645	-1,020
Useful Life	4	6
Market Value at the end of Useful Life	0	0

The least common multiple of the useful lives of alternatives *A* and *B* is 12 years. The PW slution must be based on the total study period of 12 years.

$$\begin{aligned}
 PW(10\%)_A &= -\$3,500 + \$3,500[(P/F, 10\%, 4) + (P/F, 10\%, 8)] \\
 &\quad + (\$1,900 - \$645)(P/A, 10\%, 12) \\
 &= \$1,028
 \end{aligned}$$

$$\begin{aligned}
 PW(10\%)_B &= -\$5,000 + \$5,000(P/F, 10\%, 6) \\
 &\quad + (\$2,500 - \$1,020)(P/A, 10\%, 12) \\
 &= \$2,262
 \end{aligned}$$

Based on the *PW* method, the alternative *B* is selected since it provides larger the revenue value.

2.5. Machine Precision and Reliability

2.5.1. Precision

Competitive market conditions and ever improving technology have forced manufacturers to increase quality as well as productivity. Improvement of quality is realized through the enhancement of production system precision.

Deterministic theory has provided duideliness that have yielded the highest machine tools ever realized and designed. The following statement is the basis of the

Deterministic Theory: “Automatic machine tools obey cause and effect relationship that are within our ability to understand and control and that there is nothing random or probabilistic about their behaviour” Altintas [1]. In this definition, the random means that the causes of errors are not understood and cannot be eradicated. Typically these errors are quantified statistically with a known statistical distribution. It must be understood that in all cases, machine tool errors that appear random are not random.

Generally, sources of errors may be broken into four categories: geometric errors, dynamic errors, workpiece effects, and thermal errors. Geometric errors put forwards themselves in both translational and rotational errors on a machine tool. Typical causes of such errors are lack of straightness in slideways, nonsquareness of axes, angular errors, and static deflection of the machine tool. Dynamic errors are typically caused by machine tool vibration (or chatter). They are generated by exciting resonance within the machine tool’s structure through process interaction. The workpiece can effect a machine tool’s accuracy and precision in two manners: deflection during the cutting process and inertial effects due to motion. Thermal errors are probably the most significant set of factors that cause apparent nonrepeatable errors in a machine tool. They can be reduced by improving the thermal stability of the or advanced techniques.

2.5.2. Reliability

The statistical measure of the probability that a mechanical element will not fail in use is called the reliability of that element. The reliability R can be expressed by the number having the range, $0 \leq R < 1$. A reliability of $R=0.90$ means that there is a 90 percent chance that the part will perform its proper function without failure. For example the failure of 6 parts out of every 1000 manufactured might be considered an acceptable failure rate for a certain class of products. This reliability equals to:

$$R = 1 - \frac{6}{1000} = 0.994 \text{ or } 99.4 \text{ percent.}$$

In design, first a reliability goal is determined and then materials, geometry and processes are determined according to this rate. For example, if the objective reliability is to be 99.4 percent, what combination of materials, processing, and dimensions is needed to meet this goal?

Reliability values of the machines are calculated by the machine manufacturers, and then this predefined values are used to compare alternatives.

2.6. Application Environment

Intelligent machine tool selection software, with machine database, is developed to implement decision support methodology. It uses AHP method, and runs precision, reliability and cost analysis.

2.6.1. Implementation Tool

Decision support system is implemented by using visual basic (VB). VB bases a language on one of the world's most widely known languages. Endow the language with the ability to conveniently build applications for Microsoft Windows. Make the language appropriate for implementing internet-based and World-Wide-Web-based applications, and build in the features people really need graphics, strings, graphical user interface components, error handling, multimedia, file processing and database processing. These features are precisely what businesses and organizations need to meet today's information processing requirements.

Visual Basic empowers programmers to unleash their creativity. They will quickly produce applications that go well beyond anything they would have produced in introductory programming courses in procedural languages like C, Pascal and non-visual versions of Basic.

Visual Basic is a Microsoft Windows programming language. Visual Basic programs are created in an Integrated Development Environment (IDE). The IDE allows programmer to create, run and debug Visual Basic programs conveniently. IDEs allow a programmer to create working programs in a fraction of the time that it would normally take to code programs without using IDEs.

Visual Basic is derived from the BASIC programming language. Visual Basic is a distinctly different language providing powerful features such as graphical user interfaces, event handling, and access to Win32 API, object oriented features, error handling, structured programming, and much more.

2.6.2. Database

A database is simply a collection of data, stored in an organized fashion. For example, it may be an address list, employee details or about items that make up the stock in a store. A database is composed of tables, which is structured in a way that will allow you to work with the data when and as required.

Any of the following database applications can be used and written in a Visual Basic application that accesses the data within the database:

- Microsoft Access
- DBASE
- Excel
- FoxPro
- Lotus
- Paradox
- Text-based data files

Some databases, such as Microsoft Access, store all the related database files in a single global file called the database file. Other database systems, such as dBASE, keep track of an application's files separately and each file that contains data in rows and fields is a database file.

Microsoft Access is selected for a database management system. This means that an Access database can contain several tables of data, which can be related to each other through common. Using Microsoft Access, all information can be managed from a single database file. Within the file, data can be divided into separate storage containers called tables; view, add, and updated table data using online forms; found and retrieves just the using queries and analyzed or printed in a specific layout using reports.

A record contains information about a single item in your table. For example, the details of one customer are held in that customer's record. The information is broken down into several fields. Every record in the table will have the same structure of fields. A field is a piece of data with a record, identified by a name. For example, in the customer's table, the field names maybe: first name, last name, id, address, phone number etc.

When working with MS Access, there are seven different types of objects, (tables, queries, forms, reports, pages, macros and modules) which are used to work with the data.

Tables which are used for data entry, viewing data and displaying the results of queries, are the most important object in your database. In a table, each record is displayed as a row and each field is displayed as a column. When creating tables an extra time should be spent in table design, since it can result in enormous time savings during later stages of the project. A key is a one or more field that uniquely determines the identity of the real-world object that the record is meant to represent.

Queries are used to locate specific records within tables. Forms provide the front side of your database application. It is the part of the database application that the users interact with. Reports can be used to produce various printed outputs from data in user's database.

2.6.3. Database Management

A database system involves the data itself, the hardware on which the data resides, the software (called the database management system or DBMS) that controls the storage and retrieval of data, and the users themselves.

The following lists the advantages of database systems.

- (1) Redundancy can be reduced.
- (2) Inconsistency can be avoided.
- (3) The data can be shared.
- (4) Standards can be enforced.
- (5) Security restrictions can be applied.
- (6) Integrity can be maintained.
- (7) Conflicting requirements can be balanced.

One of the most important aspects of database systems is the data independence (i.e. applications need not be concerned with how the data is physically stored or accessed). Data independence makes it convenient for various applications to have different views of the same data.

2.7 Summary

In chapter 2, the background information which is to better understand the problem, framework of the software and solution methodology are presented. First, the machine selection literature is reviewed. However, studies in machine tool selection by using AHP are limited. Most of them have examined economical side of the machine tool selection with AHP. Second, multi criteria decision-making and methods (AHP, revised AHP, the weighted-sum-model method and the weighted-product-model method) are explained and summarized. AHP methodology is explained in detail since the software based on this method. Third, sensitivity analysis is defined and the methods for determining the most critical criterion and the most critical measure of performance are reviewed. The cost analysis is necessary for comparing alternatives from economical side. Fourth, the cost analysis methods for analyzing cash flow, the present

worth method, the future worth method and the annual worth method, are reviewed, and how to compare alternatives by using these methods is described with examples. As a result, application environment is described. Software is implemented by Visual Basic by using Microsoft Access database. The advantages and objects of Microsoft Access are proposed. Moreover, database management importance and database management tools are required in order to construct efficient software.

3. DECISION METHODOLOGY

Chapter 3 presents decision methodology used in the machine selection problem. First, decision criteria and machine specifications, which are used in AHP, are demonstrated. In addition, machining terms and parts used in decision process are explained. Second, the application of the AHP is explained with the methodology that is used in the software. Fourth, a cost analysis is performed on the solution found by AHP. Fifth, reliability and precision analysis are explained and applied on the results. Sixth, the results and decision criteria are analyzed by applying sensitivity analysis on AHP results to determine the most critical criteria and the most critical measure of performance. Last, the machine selection methodology is explained step by step

3.1. Decision Criteria and Machine Specifications

This section explains decision criteria and machine specifications that are used in the decision process.

3.1.1. Decision Criteria

In general, in a machine selection process, first the user defines his preferences, and according to these preferences, the best machine from available machine data set is selected.

In this problem, there are four main categories each having different requirements. These four main criteria with sub-criteria are shown in Table 3.1 and Table 3.2. The main criterion directly depends on sub-criteria. For example, productivity depends on six sub-criteria such as speed, horsepower, cutting feed, etc. However, flexibility depends on nine factors as it is seen in Table 3.2. Safety and Environment is also an important criterion, which is important for satisfying the

standards. Adaptation is the suitability of machine to the existing environment or system. There are four adaptability criteria: taper#, space requirement, coolant type, and CNC type. For example, space requirement of the machine is a kind of adaptability measure. The selected machine must fit the manufacturing area.

Beside these main criteria, some features desired by the decision-maker are used to eliminate unnecessary machines such as machine type, manufacturer, column construction, axis, number of ranges etc.

Table 3.1 Simple Criteria

1. Productivity	speed, power, cutting feed, etc.
2. Flexibility	# of tools, rotary table, etc.
3. Safety and Environment	mist collector, safety door, fire extinguisher, etc.
4. Adaptability	CNC type, taper #, etc.

Table 3.2 Detailed Criteria

1. Productivity	2. Flexibility
P1. Max. Speed	F1. U Axis
P2. Horse Power	F2. Articulated Axis
P3. Tool to tool time	F3. No of Pallets
P4. # Of Spindles	F4. Rotary Table
P5. Rapid Traverse Speed	F5. Total # of tools
P6. Cutting Feed	F6. Head Changer
	F7. CNC or not?
	F8. Index Table
	F9. Dual Axis Rotary Table

3. Safety and Environment	4. Adaptability
SE1. Safety Door	A1. Taper #
SE2. Fire extinguisher	A2. Space requirement of the machine
SE3. Mist Collector	A3. CNC Control Type
	A4. Coolant Type

3.1.2. Classification of Machines (Database Structure)

For selecting the best machine, creating a large database which includes all machines in the market, is the first and the most important step. Before entering machines into a defined database, the fields should be determined and defined. These fields should contain machine features, which are standard in the market. Therefore, at the beginning, a standard classification, which is used for constructing database frame, is prepared as it is in the Table 3.3.

Table 3.3 Simple machining center specifications

1. General	company name, machine name, machine type, CNC type, column style type, etc.
2. Spindle	Spindle type, spindle direction type, taper number, max. Speed, power, etc.
3. Tooling	number of tools, tool diameter, etc.
4. Work Support	table size, rotary table, etc.
5. Axis	number of axis, cutting feed, rapid traverse speed, etc.
6. Dimensions and Weight	machine dimensions, machine weight, etc.

General fields identifies the general information about the machine. Machine name is a unique field, which is different for different machines. CNC type can be unique for different manufacturers. Spindle contains information about spindle specifications (Figure 3.1). Tooling keeps information about number of tools, tool diameter, tool change time, head changer etc. that are necessary to measure the machine tool performance. Work support deals with the place where the workpiece stands. Axis information about candidate machines is stored in the axis specification. In the last field, physical information about the machine such as dimensions, weight etc. are stored.

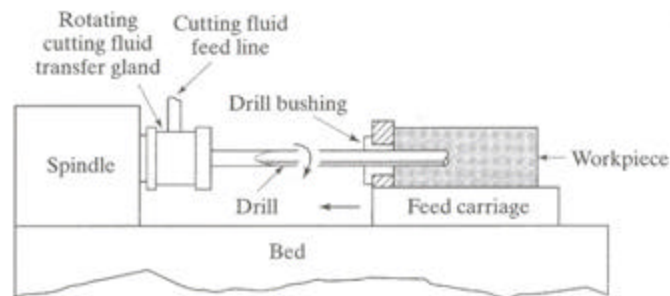

Figure 3.1 Machine Spindle

Table 3.4 Detailed Machining Center Specifications

1. General	2. Spindle	3. Tooling
G1. Company Name	S1. Type	T1. Primary Tool Carrier
G2. Machine Type	S2. Direction	T2. Number of Tools
G3. CNC Control	S3. Taper	T3. Max Tool Length
G4. Column Style	S4. Max Speed RPM	T4. Max Tool Diameter
G5. Column Construction	S5. Num of Ranges	T5. Tool Diameter Option
G6. Work Support	S6. Horse Power	T6. Max Tool Weight
G7. Machine Name	S7. Num of Spindle	T7. Tool Change Time
	S8. Articulated Axis	T8. Chip to Chip Time
	S9. U Axis	T9. Head Changer

4. Work Support	5. Axis	6. Dimensions
W1. Table Size Length	A1. Number of Axis	P1. Machine Dim. L
W2. Table Size Width	A2. X1	P2. Machine Dim. W
W3. Max Workpiece Weight	A3. Y1	P3. Machine Dim. H
W4. Auto Pallet Changer	A4. Z1	P4. Machine Weight
W5. Number of Pallets	A5. A1 (Degrees)	P5. Spindle Nose to Table (Min)
W6. Index Table	A6. B1 (Degrees)	P6. Spindle Nose to Table (Max)
W7. Index Table degrees	A7. C1 (Degrees)	P7. Spindle Center to Column
W8. Rotary Table	A8. X1 Cutting Feed	P8. Spindle to Table Center
W9. Dual Axis Rotary Table	A9. Y1 Cutting Feed	P9. Spindle to Table Edge
	A10. Z1 Cutting Feed	
	A11. A1 Cutting Feed	
	A12. B1 Cutting Feed	
	A13. C1 Cutting Feed	
	A14. X1 Rapid Traverse	
	A15. Y1 Rapid Traverse	
	A16. Z1 Rapid Traverse	
	A17. A1 Rapid Traverse	
	A18. B1 Rapid Traverse	
	A19. C1 Rapid Traverse	

A machining center is a computer controlled machine tool capable of performing a variety of cutting operations on a different surfaces and different directions on a workpiece. Figure 3.2 shows a general machining center. The workpiece in a machining center is placed on the table that can be moved in various directions. After a cutting operation is completed, it is not necessary for a workpiece to move another machine for additional operations such as drilling, reaming etc. In machining center, tools are brought to the workpiece.



Figure 3.2 Machining Center

After all cutting operations have been completed, the pallet usually automatically moves away with the finished workpiece, and another pallet containing the new workpiece to be machined is brought into position by an automatic pallet changer. All movements are computer-controlled, and pallet-changing cycle times are about 10 to 30 seconds. The machines can also be equipped with various automatic parts, such as loading and unloading devices.

The machining center is equipped with a programmable automatic tool changer. Depending on the design, up to 200 cutting tools can be stored in a magazine. Auxiliary tool storage is available on some special machining centers for more cutting tools.

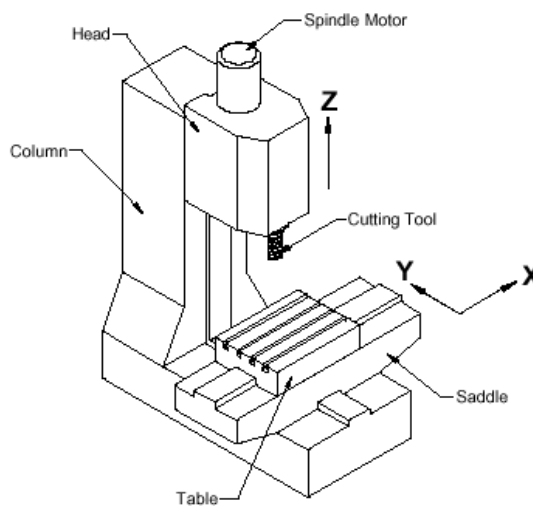

Figure 3.3 Three Axis Machining Center

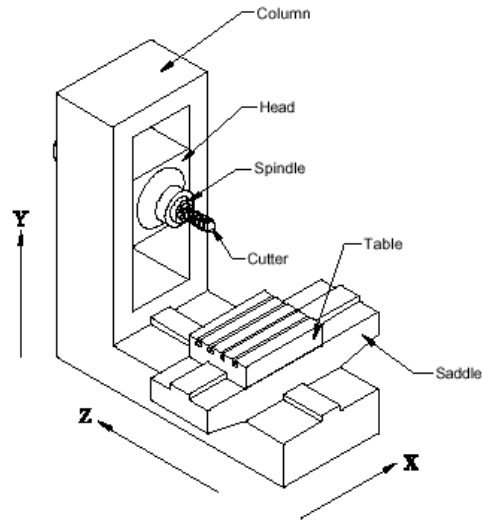

Figure 34 Three Axis Horizontal Machining Center (3 Linear Axes)

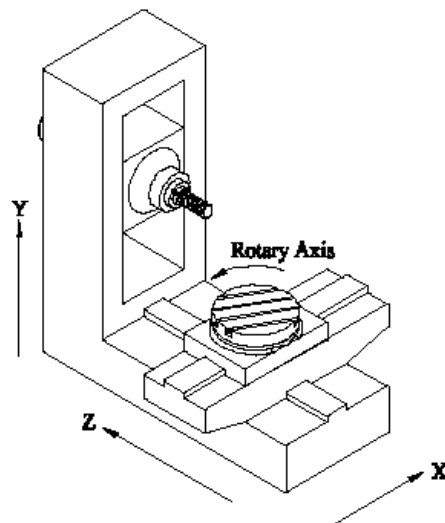

Figure 35 Four Axis Machining Center (3 Linear and 1 Rotary Axes)

Although there are various designs for machining centers, two common types are vertical spindle and horizontal spindle. Vertical-spindle machining centers (vertical machining centers) are suitable for performing various machining operations on flat surfaces with deep cavities (i.e. mold and die making). They may have four axes of motion. Three are linear motions of the table while the fourth is the table's rotary axis. Horizontal-spindle machining centers (horizontal machining centers) are suitable for

large as well as tall workpieces that require machining on a number of surfaces. Like vertical machining centers, horizontal centers may have multiple-axis table movements. Typically, the horizontal center's table rotates to present all four sides of a workpiece to the tooling. The machining centers that are both equipped with vertical and horizontal spindles are called universal machining centers. They are capable of machining all surfaces of a workpiece.

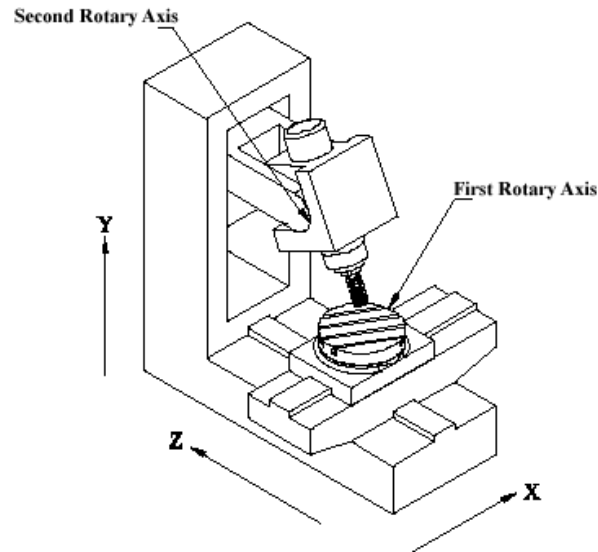

Figure 3.6 Five Axis Machining Center (3 Linear and 2 Rotary Axes)

3.2. The Analytic Hierarchy Process

Machine selection problem is selecting the best machine between numbers of alternatives under decision criteria. The AHP is used to rank machines from the best to worst. AHP is directly applied on the machine selection problem except comparing alternatives. For a typical machine selection there are more than one hundred alternatives.

AHP enables the user to determine the criteria weights by using comparison matrices. Although the determination of the criteria weights in a multi-criteria-weighted-average-method is critically important, AHP offers a simple approach given in the following.

For machine selection problem, the hierarchy tree consists three levels:

Level1: This level contains the goal, which is the selection of the best machine.

Level2: It contains four main criteria.

Level3: This level consists of sub-criteria based on the machine specifications.

The procedure of AHP for machine tool selection is the following:

Step 1: Select main criteria.

For example, the decision-maker selects productivity and flexibility.

Step 2: Select sub-criteria.

Productivity has six sub criteria such as maximum speed, main spindle power, tool-to-tool time, # of spindles, rapid traverse speed and cutting feed. Among these six, four of them are selected: maximum speed, main spindle power, tool to tool time and number of spindles.

Step 3: Compare selected sub-criteria to calculate score.

For this comparison, decision-maker asks this question “How important the maximum speed against the main spindle power?”

Decision-maker uses the following rates of importance:

Equal (1), equal-moderate (2), moderate (3), moderate-strong (4), strong (5), strong- very strong (6), very strong (7), very strong - extreme (8), extreme (9).

Table 3.5 Sub-Criteria Comparisons for Productivity

	Number of Spindles	Maximum Speed	Tool-To-Tool Time	Main Spindle Power
Number of Spindles	-	Moderate		Equal-Moderate
Maximum Speed		-		
Tool-To-Tool Time	Equal-Moderate	Strong	-	Moderate
Main Spindle Power		Equal-Moderate		-

Table 3.6 Sub-Criteria Comparison Values for Productivity

	Number of Spindles	Maximum Speed	Tool-To-Tool Time	Main Spindle Power
Number of Spindles	1	3	0.5	2
Maximum Speed	0.33	1	0.2	0.5
Tool-To-Tool Time	2	5	1	3
Main Spindle Power	0.5	2	0.33	1

Step 4: Construct pair-wise comparison matrix for sub-criteria.

Each rate of importance equals to numerical value as it can be seen above. These rates are replaced by their equivalent numerical values for the pair-wise comparison matrix.

Step 5: Normalize the pair-wise comparison matrix.

For productivity sub criteria, normalize matrix by dividing each column values by the total column sum.

Table 3.7 Sub-Criteria Normalized Comparison Values for Productivity

	Number of Spindles	Maximum Speed	Tool-To-Tool Time	Main Spindle Power
Number of Spindles	0.260	0.272	0.245	0.307
Maximum Speed	0.086	0.090	0.098	0.076
Tool-To-Tool Time	0.521	0.454	0.491	0.461
Main Spindle Power	0.130	0.181	0.163	0.153

Step 6: Calculate the scores (the relative weights) of the criteria by taking the average value of each row.

Table 3.8 Relative Weights for Productivity

	AVG
Number of Spindles	0.271
Maximum Speed	0.088
Tool-To-Tool Time	0.482
Main Spindle Power	0.157

The scores of the sub-criteria of productivity are as follows:

$$s_{P/NumberOfSpindles} = 0.271, s_{P/MaximumSpeed} = 0.088, s_{P/ToolToToolTime} = 0.482,$$

$$s_{P/MainSpindlePower} = 0.157$$

Table 3.9 Sub-Criteria Comparisons for Flexibility

	Articulated Axis	Head Changer	Total # of Tools	U Axis
Articulated Axis	-			
Head Changer	Moderate - Strong	-	Moderate	Equal-Moderate
Total # of Tools	Equal-Moderate		-	
U Axis	Moderate		Equal-Moderate	-

For flexibility, four sub-criteria (articulated axis, head changer, total number of tools and U axis) are selected. These sub criteria are rated, comparison matrix is constructed and the scores of the sub-criteria for flexibility are calculated in the steps 2-6 as shown in the following

Table 3.10 Sub-Criteria Normalized Comparison Values for Flexibility

	Articulated Axis	Head Changer	Total # of Tools	U Axis
Articulated Axis	1	0,25	0,5	0,333
Head Changer	4	1	3	2
Total # of Tools	2	0,333	1	0,5
U Axis	3	0,333	2	1
<i>Column Sum</i>	10	1,9166	6,5	3,833

Table 3.11 Relative Weights for Flexibility

	Articulated Axis	Head Changer	Total # of Tools	U Axis	AVG
Articulated Axis	1	0,25	0,5	0,333	0,098
Head Changer	4	1	3	2	0,476
Total # of Tools	2	0,333	1	0,5	0,164
U Axis	3	0,333	2	1	0,260

The scores of the sub-criteria for flexibility are:

$$s_{F/ArticulatedAxis} = 0.098, s_{F/HeadChanger} = 0.476, s_{F/Total \# \text{ of tools}} = 0.164,$$

$$s_{F/UAxis} = 0.260$$

Table 3.12 Main Criteria Comparisons

	Productivity	Flexibility
Productivity	-	Moderate - Strong
Flexibility		-

Step 7: Compare selected main criteria to calculate score.

As an example, after comparing the sub-criteria of each main criterion and calculating the scores for the sub-criteria, productivity and flexibility are compared as follows.

Step 8: Calculate score for main criteria (steps 4-6).

Construct pair-wise comparison matrix

Table 3.13 Main Criteria Normalized Comparison Values

	Productivity	Flexibility
Productivity	1	4
Flexibility	1/4	1

Calculate main criteria scores:

Table 3.14 Main Criteria Comparison Values

	Productivity	Flexibility
Productivity	1	4
Flexibility	1/4	1
<i>Column Sum</i>	1.25	5

Table 3.15 Main Criteria Comparison Values

	Productivity	Flexibility	AVG
Productivity	1	4	0,8
Flexibility	1/4	1	0,2

$$S_{\text{Productivity}} = 0.8, S_{\text{Flexibility}} = 0.2$$

After each pair-wise comparison (for both main and sub-criteria), consistency is examined. For sub criteria of productivity and flexibility, the consistency calculations are performed and the following ratios are determined, $P_{CI/RI4} = 0.0053$ and $F_{CI/RI4} = 0.014$. According to these scores, the decision matrix for productivity and flexibility are consistent enough to make a decision. Consistency check is also performed for the main criteria matrix consisting of productivity and flexibility, and $M_{CI/RI4} = 0$ was obtained which means it is consistent.

Step 9: Calculate overall score for criteria by multiplying main criteria score with sub-criteria score.

$$S_{\text{Number of Spindles}} = S_{\text{P/Number of Spindles}} * S_{\text{Productivity}} = 0.271 * 0.8 = 0,217,$$

$$S_{\text{Maximum Speed}} = S_{\text{P/Maximum Speed}} * S_{\text{Productivity}} = 0.088 * 0.8 = 0,070,$$

$$S_{\text{Tool-To-Tool Time}} = S_{\text{P/Tool-To-Tool Time}} * S_{\text{Productivity}} = 0.482 * 0.8 = 0,385,$$

$$S_{\text{Main Spindle Power}} = S_{\text{P/Main Spindle Power}} * S_{\text{Productivity}} = 0.157 * 0.8 = 0,126,$$

$$S_{\text{Articulated Axis}} = S_{\text{F/Articulated Axis}} * S_{\text{Flexibility}} = 0,098 * 0.2 = 0,019,$$

$$S_{\text{Head Changer}} = S_{\text{F/Head Changer}} * S_{\text{Flexibility}} = 0,476 * 0.2 = 0,095,$$

$$S_{\text{Total \# of tools}} = S_{\text{F/Total \# of tools}} * S_{\text{Flexibility}} = 0,164 * 0.2 = 0,032,$$

$$S_{\text{UAxis}} = S_{\text{F/UAxis}} * S_{\text{Flexibility}} = 0,260 * 0.2 = 0,052,$$

3.3. Selecting the Best Machine

As a result of AHP, decision maker's preferences are converted into the numerical value. Then, the best machine is selected among the machines in the database.

3.3.1. Eliminating Alternatives

Database contains specifications about machining centers. Some of these exact specifications are not suitable in AHP process. For example, machine name can be specified clearly. Decision-maker may want to select among machines that are produced by MAZAK. Therefore decision-maker can eliminate some machine alternatives by setting some values in Table 3.5.

3.3.2. Applying Scores on the Alternatives

After an alternative set is determined, scores are applied on these alternatives as follows:

Table 3.16 Machine Alternatives

Name	Company	TY	MS	AA	TTT	NS	UA	MSP	NT	HC
V-100	Mazak	MC	3150	Opt.	32	1	None	35	80	Std.
V-40	Mazak	MC	4000	None	20	1	None	25	30	Std.
V-515	Mazak	MC	6000	None	18	1	None	25	30	None
MX-40HA	Okuma	MC	7000	None	6	1	None	15	40	None
MX-50HB	Okuma	MC	5000	None	10	1	None	27	40	None
CTV-40	Okuma	MC	8000	None	15	1	None	10	20	None

MC=Machining Center, TY=Type, MS=Maximum Speed, AA=Articulated Axis, TTT= Tool-to-Tool Time, RTS = Rapid Traverse Speed, UA= U Axis, NS= Number of Spindles , NT= Number of Tools, HC= Head Changer.

For example, there are six machine alternatives shown in the Table 3.16. In order to calculate each machine's score, the scores that are found by AHP are used. Score for machine V-100 is calculated as follows.

Step1: Normalize values of alternatives by dividing the value to the highest.

Table 3.17 Normalized Machine Alternative Values

Name	Company	MS	AA	TTT	NS	UA	SP	NT	HC
V-100	Mazak	0,095	1	0,316	0,166	0	0,255	0,333	1
V-40	Mazak	0,120	0	0,198	0,166	0	0,182	0,125	1
V-515	Mazak	0,180	0	0,178	0,166	0	0,182	0,125	0
MX-40HA	Okuma	0,211	0	0,059	0,166	0	0,109	0,166	0
MX-50HB	Okuma	0,150	0	0,099	0,166	0	0,197	0,166	0
CTV-40	Okuma	0,2413 273	0	0,148 51485	0,166 66667	0	0,072 9927	0,083 33333	0

$$\text{Maximum Speed Score} = 0,095 * s_{\text{Maximum Speed}} = 0,095 * 0,070 = 0,006$$

$$\text{Articulated Axis Score} = 1 * s_{\text{Articulated Axis}} = 1 * 0,019 = 0,019$$

$$\text{Tool-to-Tool Time Score} = 0,316 * s_{\text{Tool-To-Tool Time}} = 0,316 * 0,032 = 0,121$$

$$\text{Number of Spindles Score} = 0,166 * s_{\text{Number of Spindles}} = 0,166 * 0,217 = 0,036$$

$$\text{U Axis Score} = 0 * s_{\text{U Axis}} = 0 * 0,052 = 0$$

$$\text{Main Spindle Power Score} = 0,255 * s_{\text{Main Spindle Power}} = 0,255 * 0,126 = 0,032$$

$$\text{Total Number of Tools Score} = 0,316 * s_{\text{Total Number of Tools}} = 0,316 * 0,141 = 0,010$$

$$\text{Head Changer Score} = 1 * s_{\text{Head Changer}} = 1 * 0,095 = 0,095$$

For other machines, the scores are as follow s;

Table 3.18 Machine Alternatives

Name	Company	MS	AA	TTT	NS	UA	SP	NT	HC
V-100	Mazak	0,006	0,019	0,121	0,036	0	0,032	0,010	0,095
V-40	Mazak	0,008	0	0,076	0,036	0	0,022	0,004	0,095
V-515	Mazak	0,012	0	0,068	0,036	0	0,022	0,004	0
MX-40HA	Okuma	0,014	0	0,022	0,036	0	0,013	0,005	0
MX-50HB	Okuma	0,010	0	0,038	0,036	0	0,024	0,005	0
CTV-40	Okuma	0,016	0	0,057	0,036	0	0,009	0,002	0

Step2: Determine which machine specification is the best. Then, calculate total score by summing. The machine which has the highest score is selected as the best machine.

In the example, there are eight machine specifications. The machine which has the highest speed, horsepower, rapid traverse speed, pallets and tools and the smallest tool-to-tool time is the best. If the machine has the rotary table and head changer, the score of these machines should be higher than other machines.

$$\text{Total Score} = \text{MS} + \text{HP} - \text{TTT} + \text{X1-RTS} + \text{NP} + \text{RT} + \text{NT} + \text{HC}$$

Table 3.19 Machine Ranking as a Result of AHP

Name	Company	Total Score	Rank (AHP)
V-100	Mazak	0,321	1
V-40	Mazak	0,242	2
V-515	Mazak	0,144	3
CTV-40	Okuma	0,122	4
MX-50HB	Okuma	0,115	5
MX-40HA	Okuma	0,092	6

As a result of machine selection, the machine V-100 is the best machine since it has the highest score.

3.3.3. Cost Analysis

For the cost analysis, combination of the present and annual worth methods are used. Each machine has different economical values such as machine life, purchasing cost, operational cost, interest rate i.e. Annual worth methods is used to determine the economical rank of the machine since each of them has different machine lives.

Let A_{kj} is the annual cost of machine k in the year j , i is the annual interest rate, P_k is the net present value of the machine k , AW_k annual worth of machine k , OC_{kj} is the operational cost of machine k in year j , MC_{kj} is the maintenance cost of machine k in year j , and n_k is the machine life of machine k . ($j=0,1,\dots,n_k$)

The annual worth of machine k is:

$$AW_k = \frac{P_k (1+i)^n + 1}{i(1+i)^n} \tag{3.1}$$

$$P_k = A_{k0}(1+i)^0 + A_{k1}(1+i)^1 + A_{k2}(1+i)^2 + \dots + A_{kn}(1+i)^n \tag{3.2}$$

$$A_{kj} = AW_k + OC_{kj} + MC_{kj} \tag{3.3}$$

For the machines in the AHP example, the following cost values occur:

Table 3.20 Cost Values for Machines

Name	Life	%i	PC	A ₁	A ₂	A ₃	A ₄	A ₅
V-100	3	5	90K	10K	15K	18K		
V-40	4	5	60K	4K	7K	9K	12K	
V-515	2	5	70K	20K	25K			
MX-40HA	3	5	80K	28K	32K	36K		
MX-50HB	5	5	50K	7K	9K	11K	14K	16K
CTV-40	3	5	95K	33K	35K	35K		

PC=Purchasing Cost, A_j=Annual Cost for Year j

If the cost calculation method is used for the machines above, the following cost values and ranking are found.

Table 3.21 Machine Ranking as a Result of Cost Analysis

Name	Annual Cost(\$)	Rank
MX-50HB	22.7K	1
V-40	24.7K	2
V-100	47.2K	3
V-515	60K	4
MX-40HA	61.2K	5
CTV-40	69.1K	6

3.3.4. Reliability Analysis

As mentioned before, reliability is the statistical measure of the probability that a mechanical element will not fail in use. The methodology that is proposed for machine tool selection uses reliability analysis to consider the reliability values of the machines. In this analysis, first AHP is performed. Then, reliability values for each candidate machine is defined and finally, machine ranking is calculated.

For the example above, first decision preferences are determined. The reliability analysis has two decision criteria, bearing failure rate and reliability of drive system. As a result of pair-wise comparison the following weight values are calculated.

Table 3.22 Reliability Analysis Comparisons

	Bearing Failure Rate	Reliability of Drive System
Bearing Failure Rate	-	Strong
Reliability of Drive System		-

Table 3.23 Machine Reliability Values

Name	Bearing Failure Rate	Reliability of Drive System
V-100	0.6	0.7
V-40	0.9	0.7
V-515	0.8	0.8
MX-40HA	0.6	0.8
MX-50HB	0.7	0.7
CTV-40	0.5	0.9

After performing AHP on the pair-wise comparison matrix, the following weights are calculated.

$$s_{\text{BearingFailureRate}} = 0.8333, s_{\text{Reliability of Drive System}} = 1.667$$

These values are used to calculate machine rankings according to the reliability values following the procedure given in section 3.3

Table 3.24 Machine Ranking as a Result of Reliability Analysis

Name	Reliability Rank
V-40	1
V-515	2
MX-50HB	3
MX-40HA	4
V-100	5
CTV-40	6

3.3.5. Precision Analysis

In order to rank machines according to their precision values, three steps are followed. First, four main criteria about machine precision (axis precision, repeatability, static and dynamic rigidity and thermal stability) are selected. Then, AHP is performed on these selected criteria in order to find the decision-maker preferences.

Table 3.25 Comparisons for Precision Analysis

	Axis Precision	Thermal Stability
Axis Precision	-	Moderate
Thermal Stability		-

Third decision maker, define the related precision values for machines in the candidate set, and according to these values and using criteria weights, machines are ranked according to their precision values.

Table 3.26 Precision Values of Machine Alternatives

Name	Axis Precision	Thermal Stability
V-100	0.9	0.6
V-40	0.7	0.8
V-515	0.8	0.9
MX-40HA	0.6	0.8
MX-50HB	0.5	0.7
CTV-40	0.8	0.9

Table 3.27 Machine Ranking as a Result of Precision Analysis

Name	Precision Rank
V-515	1
CTV-40	2
V-100	3
V-40	4
MX-40HA	5
MX-50HB	6

3.3.6. Final Selection

After cost, reliability and precision analysis, decision-maker has four machine rankings. According to his preferences, he selects the best machine. For example, technical properties of the machine can be more important than the cost, and also he would like to buy reliable machine. Under these conditions, by looking at the machine rankings the decision-maker selects the most suitable machine. At this point, to select the best, decision-maker should define his needs clearly. There are constraints in this decision-making problem such as budget, available space in manufacturing area, precision values, power needs, flexibility of the machines and etc. The aim of the decision-maker should be to select the best machine which satisfies these constraints. For the example, here, the following rankings are calculated.

Table 3.28 Rankings for Machine Alternatives

Name	AHP Rank	Cost Rank	Reliability Rank	Precision Rank
MX-50HB	5	1	3	6
MX-40HA	6	5	4	5
V-100	1	3	5	3
V-515	3	4	2	1
V-40	2	2	1	4
CTV-40	4	6	6	2

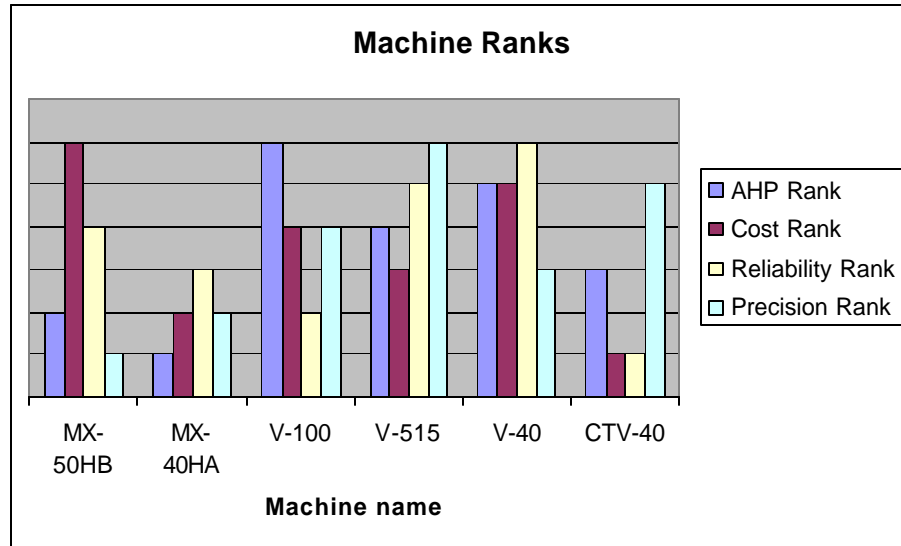

Figure 3.7 Machine Rankings

3.4. Sensitivity Analysis

Sensitivity analysis is used to improve pair-wise comparison values of main criteria during the first AHP analysis. In this part of the decision methodology, the main question; “If I assign moderate instead of strong, how will my machine ranking be affected?”. On the other hand, in the sensitivity analysis methodology, first pair-wise comparison values are increased step by step. In the example, decision-maker thinks that productivity is stronger than flexibility. This strong value is increased one step and then checked whether the machine ranking is changed. The pair-wise comparison value at which the machine ranking is changed is taken as a break point, and then the original pair-wise comparison value is decreased step by step. For example, equal-strong value is given instead of strong and it is checked, if the machine ranking is changed. If not, it is decreased one more step (equal), and so on. The values are between equal and extreme. Sensitivity analysis is performed on the results of AHP method.

Table 3.29 Comparisons for Sensitivity Analysis

	Productivity	Flexibility
Productivity	-	Strong
Flexibility		-

For the example of six machines, as a result of sensitivity analysis, the following new machine ranking list is found.

Table 3.30 New Machine Ranking as a Result of Sensitivity Analysis

Name	AHP Rank for Strong	Very Strong
MX-50HB	5	1
MX-40HA	6	3
V-100	1	2
V-515	3	4
V-40	2	6
CTV-40	4	5

3.5. Summary

In this chapter, the methodology that is necessary to solve the machine selection problem was proposed. First, four main criteria and their sub-criteria are determined. Second, the most common machine specifications are designated. Machine database was constructed using these specifications and classifications. Third, the methodology that is proposed for machine tool selection is summarized. In order to select the best machine, beside the main selection, cost, reliability and precision analysis are performed. The main steps for these analyses are also defined. In the developed methodology, AHP was proposed. The method is used to compare the criteria and machine specifications, and to rank machines from best to worst. The cost analysis is based on the annual worth method. Fifth, in order to improve pair-wise comparison values, the sensitivity analysis method was presented.

4. IMPLEMENTATION

In this part, the implementation of the developed methodology will be demonstrated. First, the application environment is demonstrated. The developed software is capable of achieving AHP application; cost, reliability, precision and sensitivity analysis. At the end of this section, all of the developed methodology will be demonstrated for possible machine selection problems.

4.1. Software

The implementation of the proposed methodology has proved to be very difficult and time consuming. Although programming with Visual Basic and Microsoft Access are very user friendly and easy, many implementation obstacles were faced such as windows and database version errors, undefined or wrong variables. However, finally, an intelligent decision support system for machine tool selection based on the proposed methodology has been developed.

First, the user should log on by entering his username, password and user type. This provides decision makers to keep track of his decision activities. For example, by entering unique username and password, each user connects to software and manages his own defaults. Default value means that, each connected user can save selection results and pair-wise comparison values for main and sub criteria. In addition, the software can remember user's ID (username and password), which provides faster connection to the software. There are three user types in the decision support system; administrator, decision-maker and guest. Administrator can manage all properties of the software, such as defining/deleting a new user, controlling user behaviors etc different

from other users. Guest can not define a machine or a machine manufacturer or make any decision. He may only investigate software properties.

After user logs on the system, he reaches on the main part. Main part of the software provides a connection between the other modules. There are four main parts of the software, machine tool selection, machines, user and administrator control. When the decision-maker connects to the system, the information about him/her (name and surname, user type and visited times) is placed at the bottom of the screen.

In order to select suitable machine, user should enter machine selection part which consists of six modules. The first one is the selection module. This module enables decision-maker to select the most appropriate machine according to his needs. Selection part uses AHP methodology in order to rank machines.

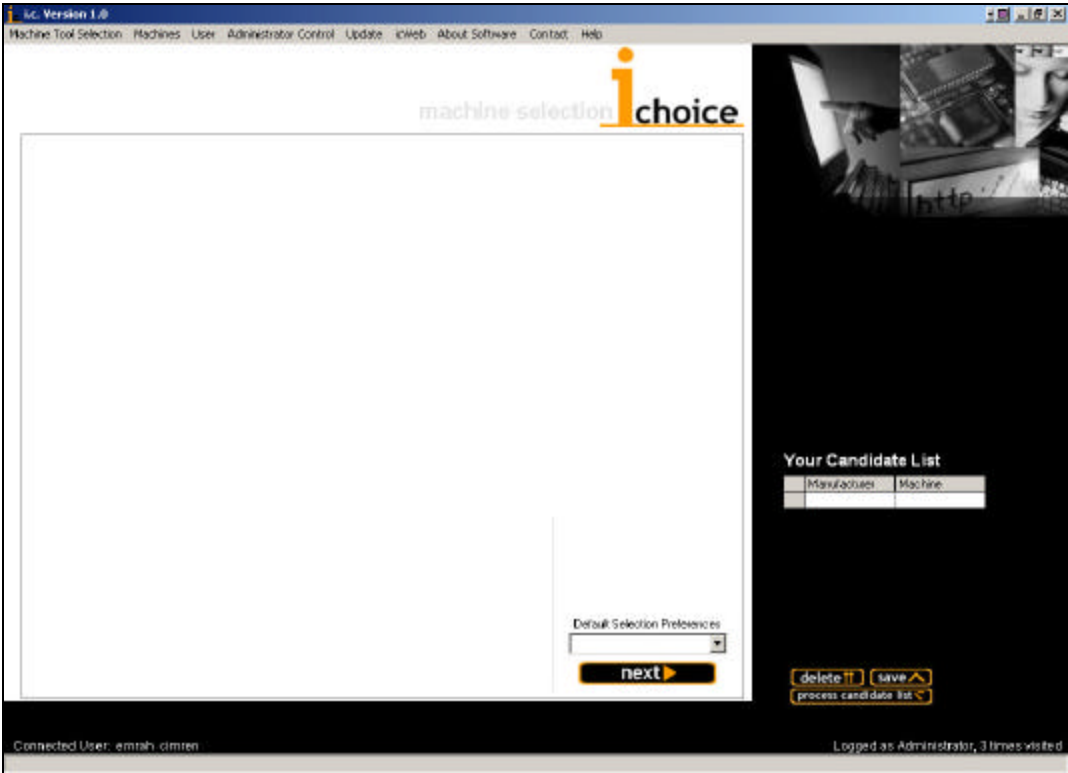

Figure 4.1 Machine Selection Screen

As it is mentioned above, the decision-maker can load predefined selection preferences. In addition, the user can add his favorite machines to the candidate list to memorize.

At the first step of the machine selection process, user defines his machine preferences. For example, user may want to select the machine, which is manufactured

by a certain company, e.g. Mazak or Okuma. In addition, user may define the speed range of the desired machine (Figure 4.2).

Figure 4.2 Machine Selection Second Step Screen (Database Search)

Figure 4.3 Machine Selection 2nd Step Screen (Guiding)

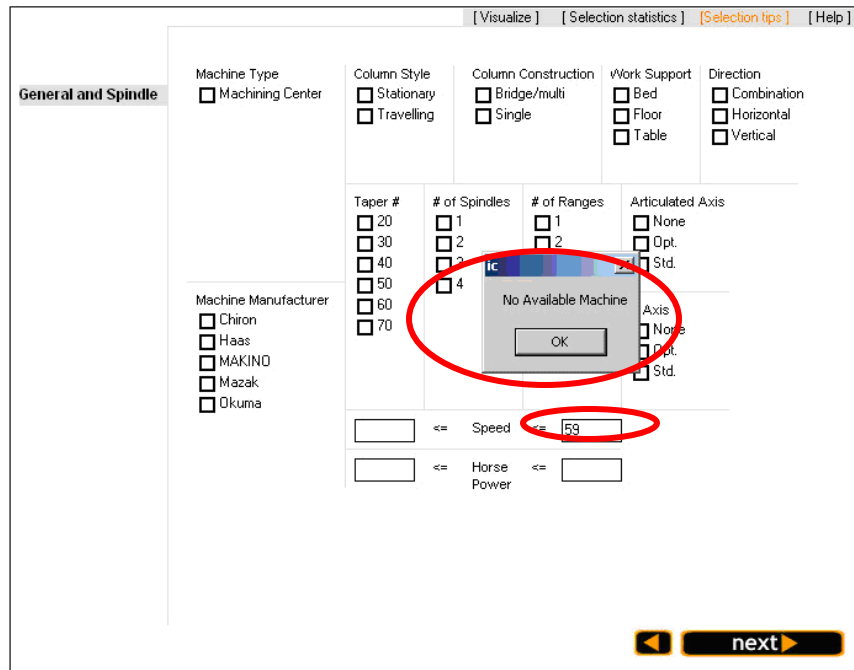

Figure 4.4 Machine Selection 2nd Step Screen (Guiding2)

Software intends to guide decision-maker during the decision process. For example, the speed value of the alternatives is between 60 and 15000. If the user enters 59 for the maximum speed, the software warns user and does not allow user to continue if he does not change the maximum speed value (Figure 4.4). If the user defines the proper values, sometimes combination of the total preferences may not give a result. In such a case, the software does not allow the user to continue. It guides user until he chooses the suitable preferences.

In the second part of the selection, user defines his choice about tooling and work support (Figure 4.5). For the next part, axis and dimension properties of the desired machine are described. So far, the software eliminates machine alternatives according to the user's needs. During this elimination process the values that are directly related to the machines such as power, dimensions, axis properties etc. are defined. As a result of the search phase, the decision-maker end up with machine alternatives.

AHP method starts after the search step. As it is seen from Figure 4.7, the decision-maker chooses the main criteria for AHP process. The software provides the user with a very user-friendly interface.

[Visualize] [Selection statistics] [Selection tips] [Help]

Tooling and Work Support

Primary Tool Carrier
 ATC

Head Changer
 None
 Opt.
 Std.

Auto Pallet Changer
 None
 Opt.
 Std.

Index Table
 None
 Opt.
 Std.

Rotary Table
 None
 Opt.
 Std.

<= # of Tools <=

<= Max Tool Length <=

<= Max Tool Diameter <=

<= Tool Diameter Option <=

<= Max Tool Weight <=

<= Tool Change Time <=

<= Chip to Chip Time <=

<= Workpiece Weight <=

<= Index Table Degrees <=

<= Table Size Length <=

<= Table Size Width <=

Dual Axis Rotary Table
 None
 Opt.
 Std.

Number of Pallets
 1
 2
 3
 4
 5
 6
 7
 8
 9

◀ next ▶

Figure 4.5 Machine Selection 3rd Step Screen

[Visualize] [Selection statistics] [Selection tips] [Help]

Axis and Dimensions

of Axis
 2
 3
 4
 5

Machine Dimensions
 <= L <=
 <= W <=
 <= H <=

Cutting Feed
 <= X1 <=
 <= Y1 <=
 <= Z1 <=

Rapid Reverse Speed
 <= X1 <=
 <= Y1 <=
 <= Z1 <=

Degrees
 <= A1 <=
 <= B1 <=
 <= C1 <=

Regular Maintenance Repair Service
 Spare Parts Training

Applied Optimization Method

◀ next ▶

Figure 4.6 Machine Selection 4th Step Screen

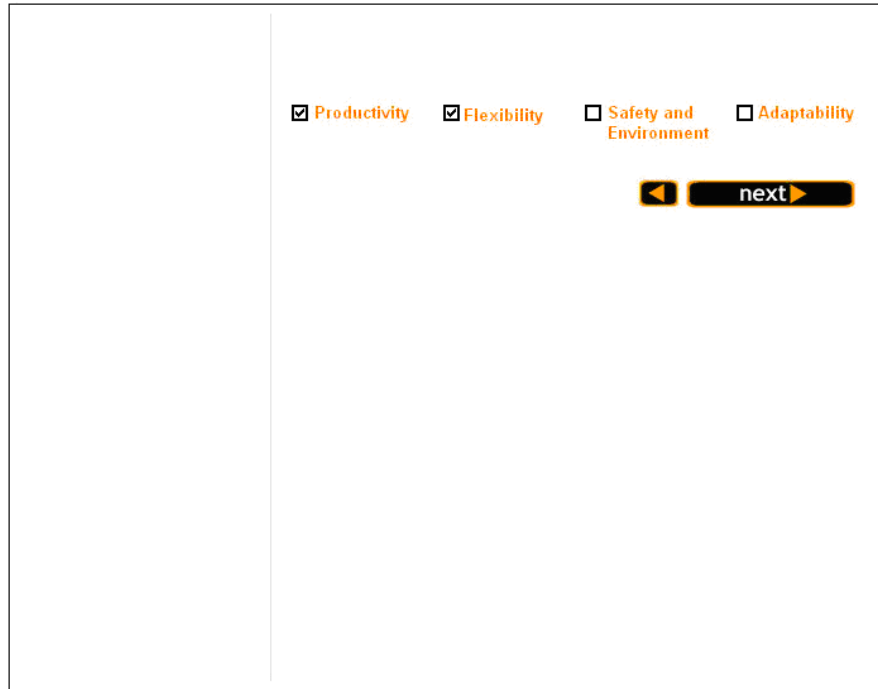

Figure 4.7 Machine Selection 5th Step Screen (AHP)

The hardest part of the selection process is the determination of the criteria and the sub-criteria, which are used during the selection process.

After determining the main criteria, the decision screen appears for each desired main criteria as seen in Figure 4.8. After the user selects the sub-criteria, he performs the pair-wise comparison for these sub-criteria (Figure 4.9). In this part, decision-maker gives qualitative values for the desired sub-criteria. Same as the first criteria, user selects the preferred sub-criteria for the second main criteria and compares these values. At the last step of the AHP method, decision-maker compares main criteria (Figure 4.10).

As a result of the selection process, the machines are ranked from the best to the worst as shown in Figure 4.11. The best machine means that the machine, which has the highest value under the defined conditions such as the machine properties, main and sub-criteria. As it is mentioned before, the user can save this result list, and the values he assigns during the selection process. These saved property values are used at the beginning of the selection process. At this point decision-maker can add the desired machines to the candidate list in order to memorize them.

After a machine selection is performed, decision-maker can apply reliability analysis, precision analysis and cost analysis on the results.

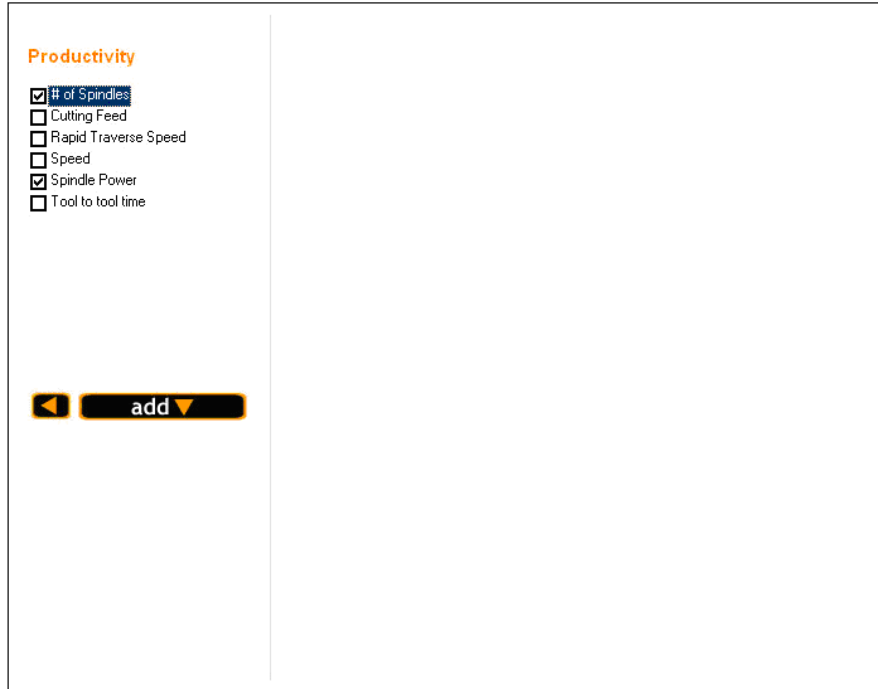

Figure 4.8 Machine Selection 6th Step Screen (AHP)

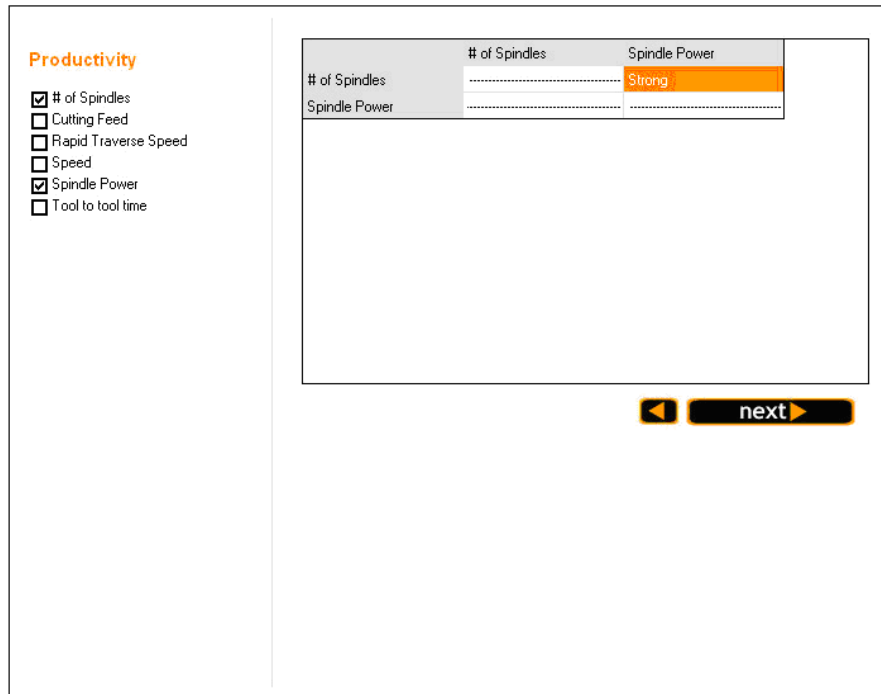

Figure 4.9 Machine Selection 7th Step Screen (AHP)

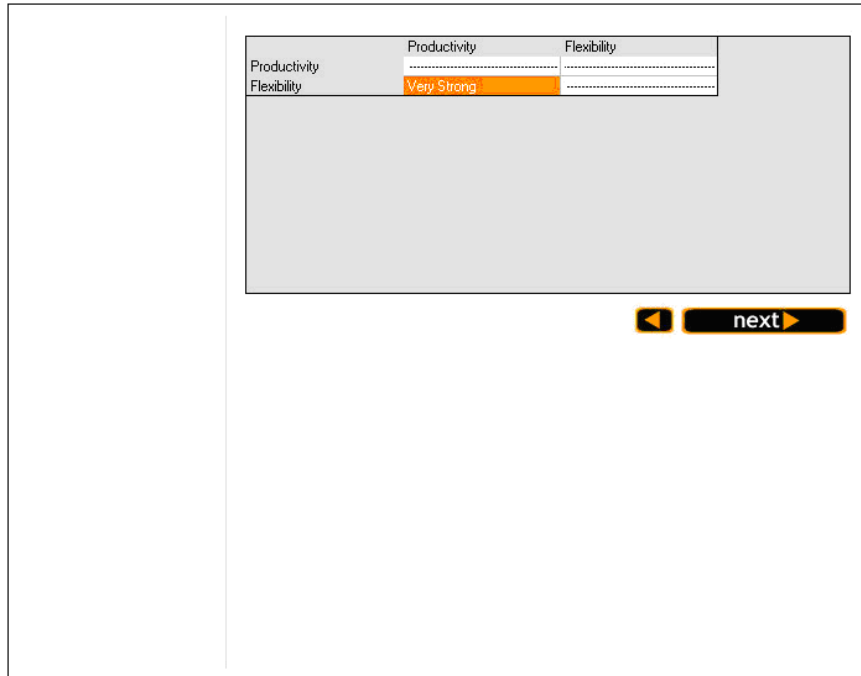

Figure 4.10 Machine Selection 8th Step Screen (AHP)

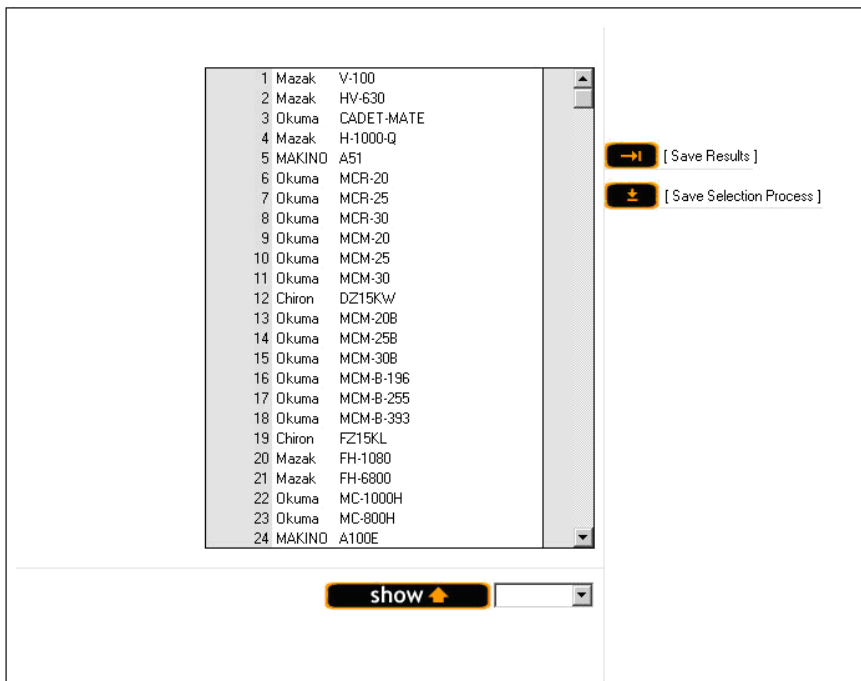

Figure 4.11 Machine Selection Results

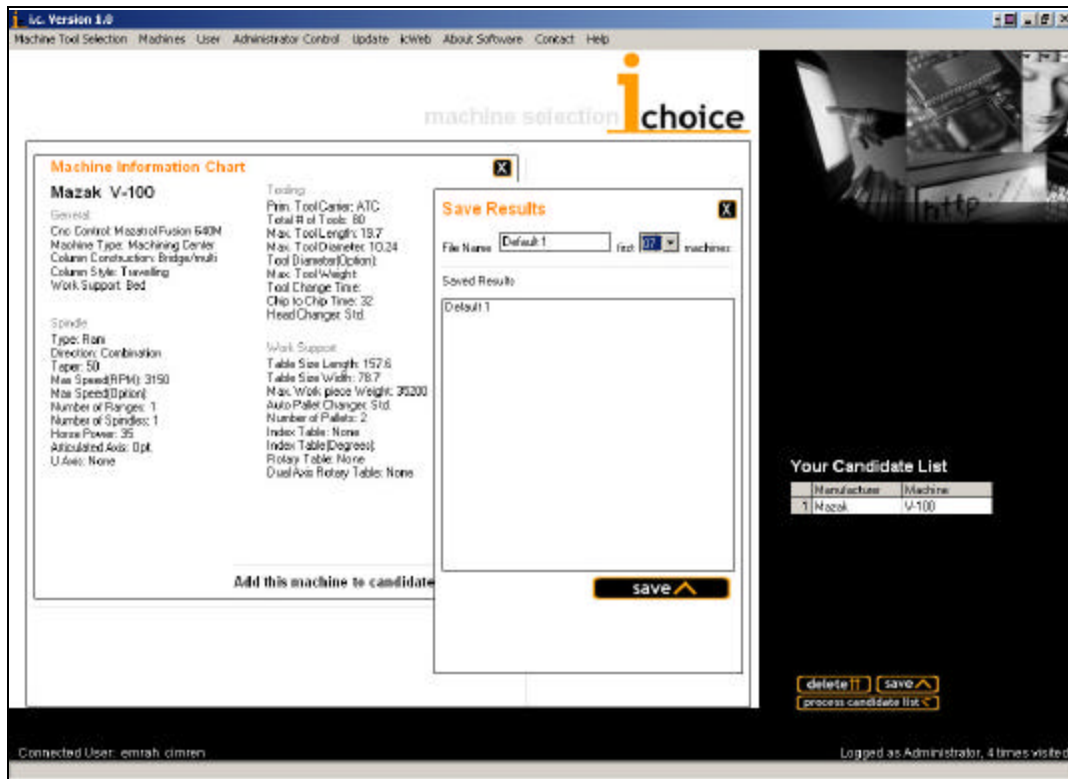

Figure 4.12 Machine Selection Results Properties

In the reliability analysis part, first user selects preferred machine results. He can load the saved machine list or machines in the candidate list or the machines that are found as a result of previous machine selection process (Figure 4.13). After loading list, decision-maker performs AHP on the reliability criteria (Figure 4.13). In order to use decision preferences coming from AHP, reliability values should be defined for each machine in the list (Figure 4.14). As a result of reliability analysis, machines are rated from the best to worst according to reliability values (Figure 4.15). At this point decision-maker can update the machines in the candidate list by considering the reliability ranking.

Decision-maker can apply precision analysis on the machine results by using the same approach in the reliability analysis. However, precision has four main criteria and decision-maker chooses according to his needs (Figure 4.16, Figure 4.17 and Figure 4.18). At the end of the precision analysis, machines are ranked according to the precision values. In the report section of the precision analysis, if reliability analysis and AHP are preformed for the machine list, rankings are analyzed for precision, reliability and AHP sections (Figure 4.19).

Cost analysis is used to evaluate alternatives by looking at cost values such as purchasing cost, operational cost and maintenance cost (Figure 4.20 and Figure 4.21).

Figure 4.13 Reliability Analysis Part 1 and 2

	Manufacturer	Machine	Bearing Failure Rate	Reliability of Drive System
1	Mazak	V-100		
2	Mazak	H-1000-Q		
3	Mazak	HV-630		
4	MAKINO	A51		
5	Okuma	MCR-20		
6	Okuma	MCR-25		
7	Okuma	MCR-30		

Figure 4.14 Reliability Analysis Part 3

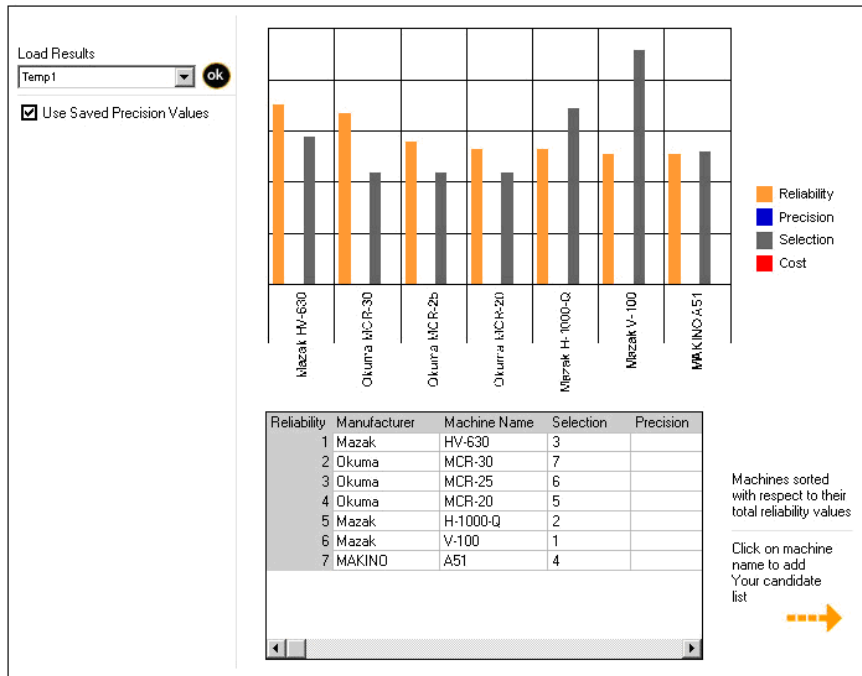

Figure 4.15 Reliability Analysis Part 4

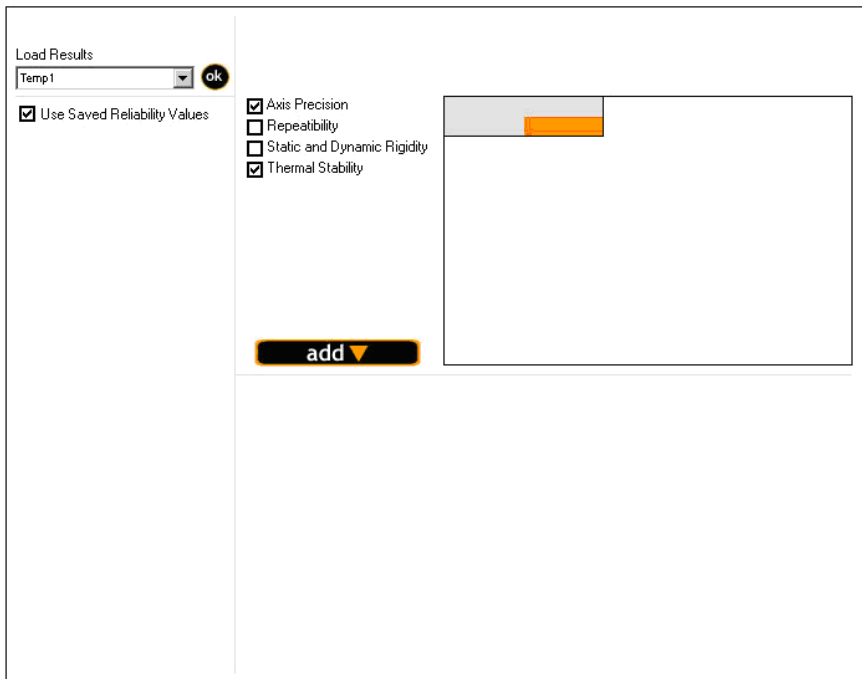

Figure 4.16 Precision Analysis Part 1

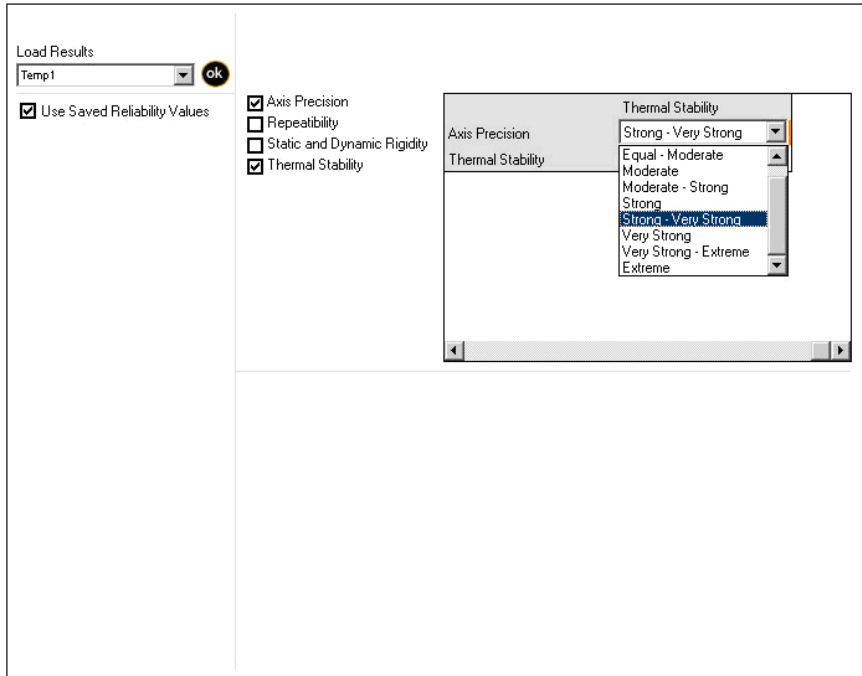

Figure 4.17 Precision Analysis Part 2

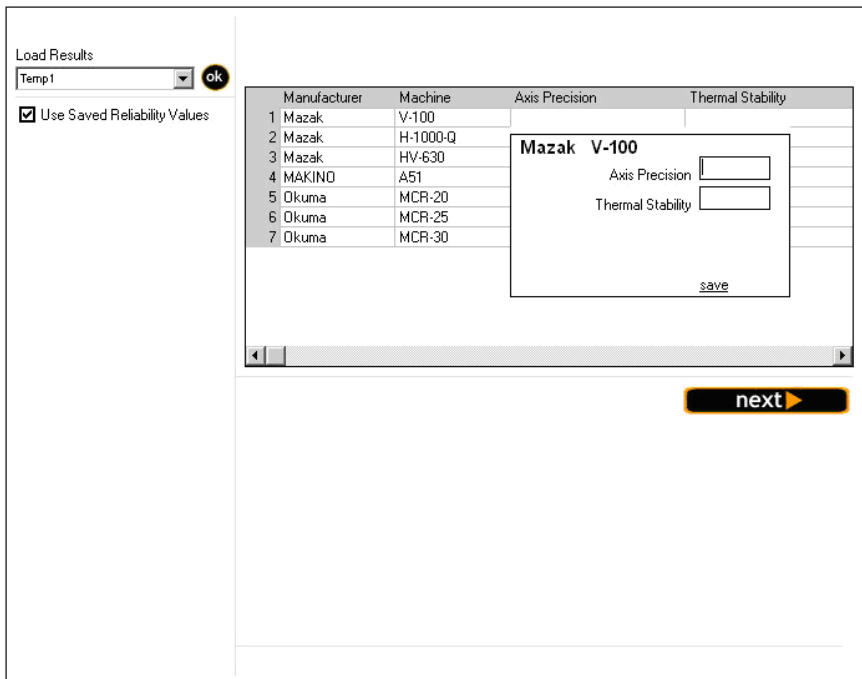

Figure 4.18 Precision Analysis Part 3

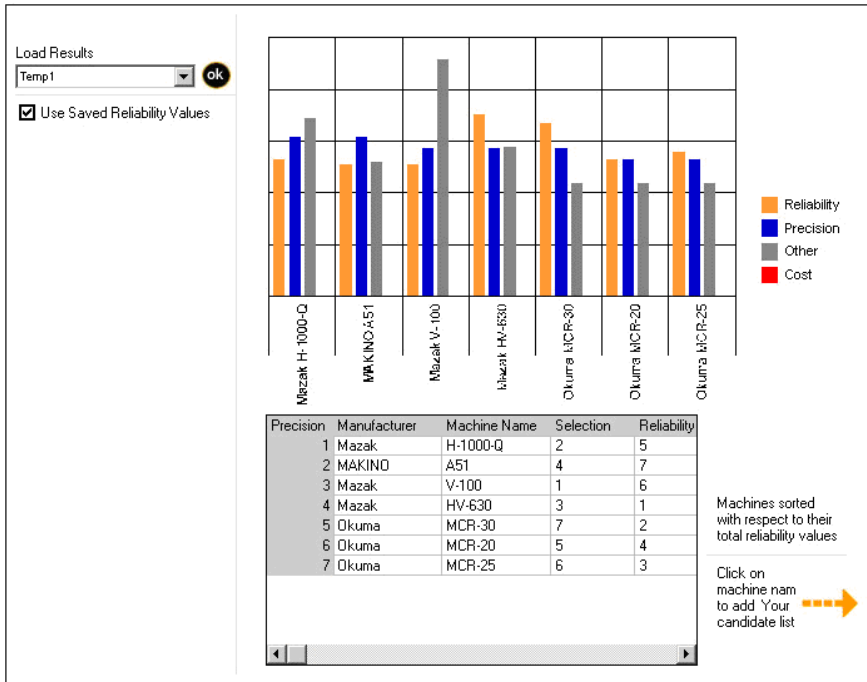

Figure 4.19 Precision Analysis Part 4

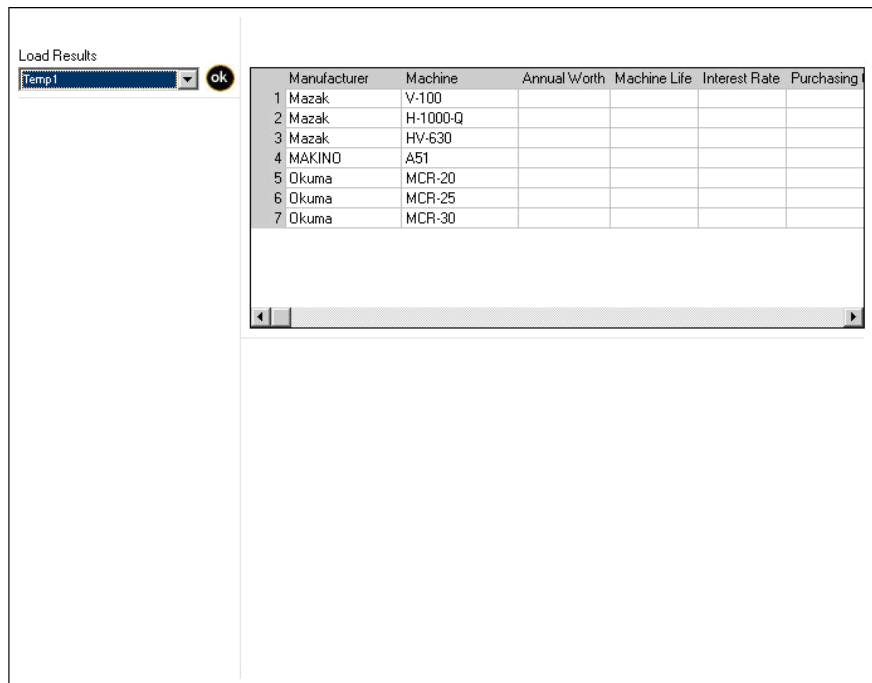

Figure 4.20 Cost Analysis Part 1

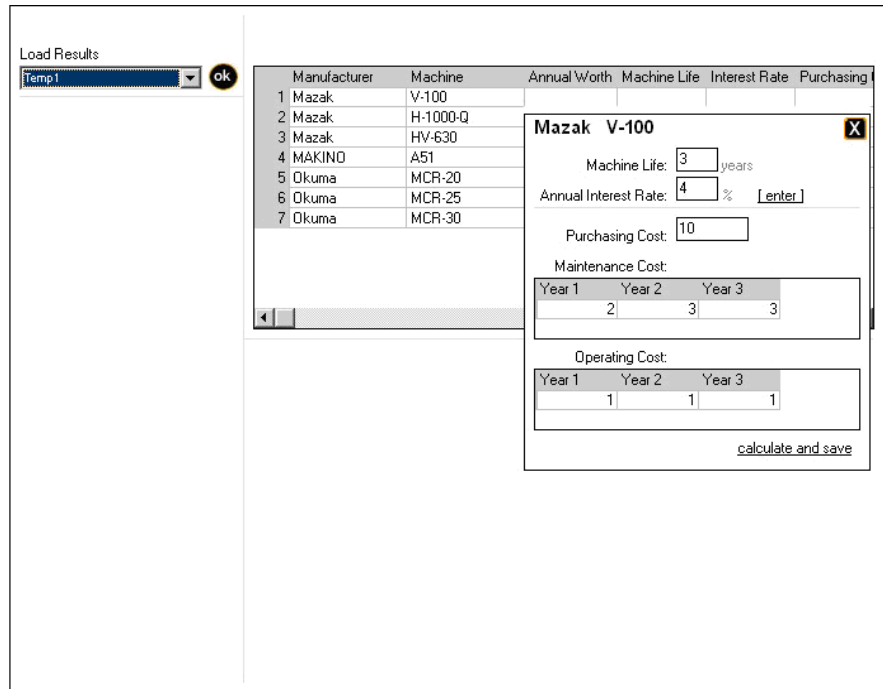

Figure 4.21 Cost Analysis Part 2

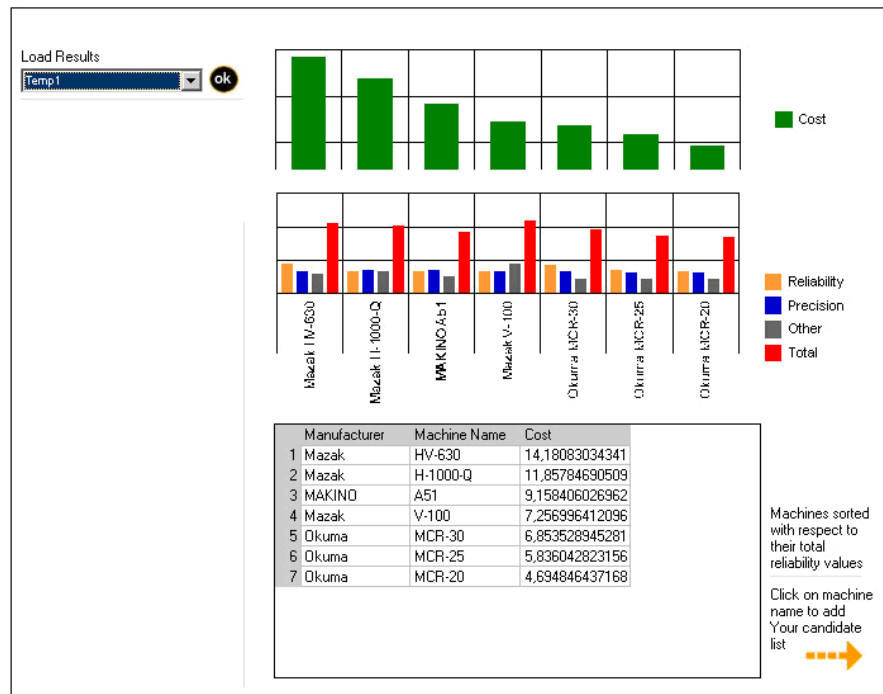

Figure 4.22 Cost Analysis Part 3

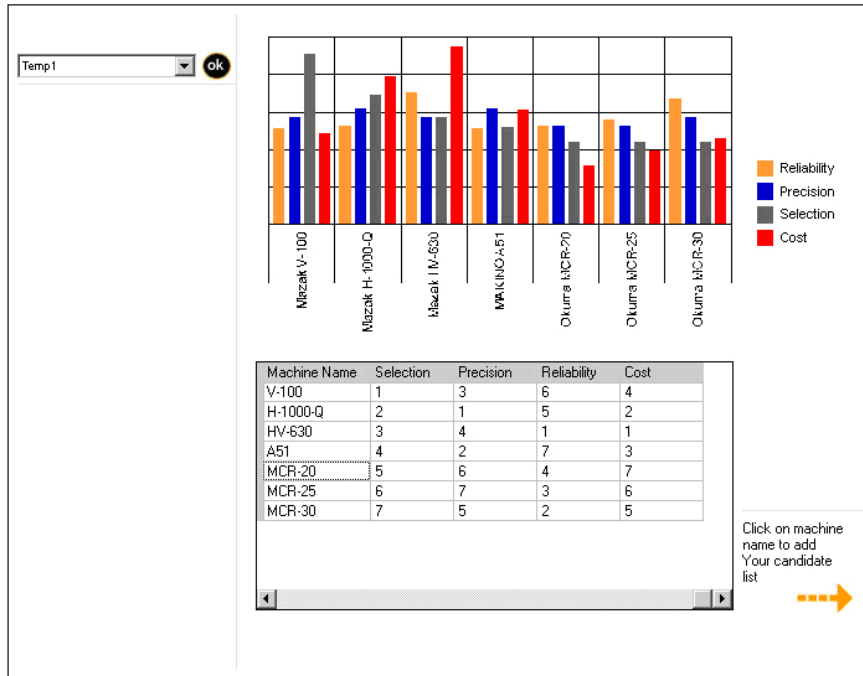

Figure 4.23 Report

Machine tool selection has also a report section as it is seen in Figure 4.23. If all analysis, AHP, reliability, precision and cost, are applied, the four machine rankings are determined for each of them. The decision maker decides which machine is selected and adds them to the candidate list.

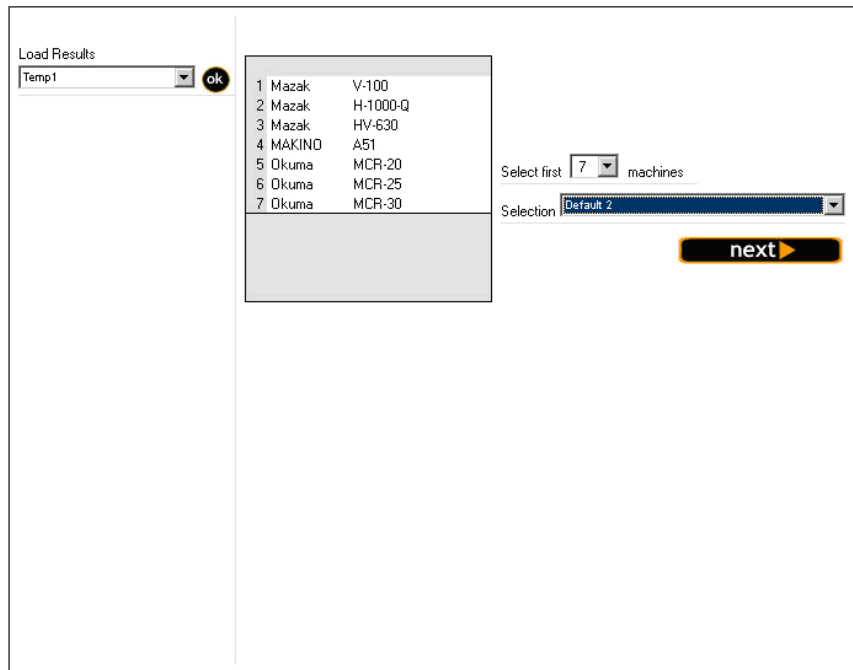

Figure 4.24 Sensitivity Analysis Part 1

The decision-maker can analyze pair-wise comparison main values in AHP by using the sensitivity analysis module. First, the user loads the desired machine results (Figure 4.24). Then, he defines the machine numbers on which the analysis performed. There are two options: analyze for the first machine position or comparison values where the machine rankings are changed (Figure 4.25). In the results, first, the analyzed value is shown in the blank part and the improvement values are placed in the next parts if the machine rankings are changed (Figure 4.26).

Beside the machine tool selection part, software contains other modules such as defining machine manufacturer and new machine. In order to define a new machine, if it is needed, the new manufacturer should be defined first (Figure 4.27). Here, user defines related information such as manufacturer name, located country, manufactured machine types, address and contact person information. Also, predefined manufacturer are listed and their related information can be edited or deleted.

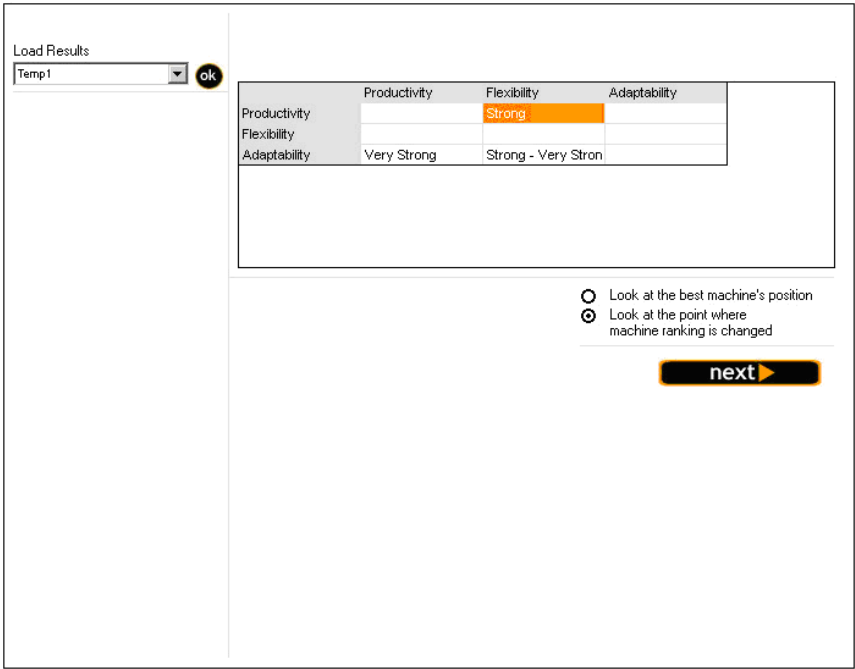

Figure 4.25 Sensitivity Analysis Part 2

Load Results

Default 2

		Strong	Strong - Very Strong	Moderate - Strong	Very Weak
1	Chiron DZ15KW		1	1	
2	Chiron FZ15KL		2	2	
3	MAKINO A77E		3	3	
4	Mazak FF-66D		5	6	
5	MAKINO A55E		6	5	
6	MAKINO A81		4	4	
7	MAKINO A66E		7	7	

Figure 4.26 Sensitivity Analysis Part 3

Chiron

General Information

Company Name:

Manufactured Machine Types: CNC Grinding Milling Turning

Located Country: Size:

Address

Address:

State/Province: Country:

Phone:

Fax:

Web:

Companies in Database

Chiron
Mazak
Haas
Okuma
MAKINO

Selected Manufacturer

Contact Person

Name - Surname:

Position:

Phone:

Fax:

e-mail:

Evaluate Company (personal)

Figure 4.27 Define A New Machine Manufacturer

For effective decision-making, the alternatives should be well defined. In the machine tool selection problem, the wider machine alternatives provide the most efficient selection. DSS software enables the decision-maker to define a new machine as it is shown in Figure 4.28.

1. General *Machine Name: <input type="text"/> *Machine Type: <input type="text"/> *Company Name: Chiron <input type="text"/> Control: <input type="text"/> Work Support: <input type="text"/> Column Style: <input type="text"/> Column Construction: <input type="text"/>		2. Spindle Type: <input type="text"/> Taper: <input type="text"/> Direction: <input type="text"/> MAX Speed RPM: <input type="text"/> Horse Power: <input type="text"/> Articulated Axis: <input type="text"/> # of Ranges: <input type="text"/> # of Spindle: <input type="text"/> U Axis: <input type="text"/>	
3. Tooling Primary Tool Carrier: <input type="text"/> Max Tool Length: <input type="text"/> Tool Diameter Option: <input type="text"/> Tool Change Time: <input type="text"/> (sec) Head Changer: <input type="text"/> # of Tools: <input type="text"/> Max Tool Diameter: <input type="text"/> Max Tool Weight: <input type="text"/>		4. Work Support Table Size Length: <input type="text"/> Max Workpiece Weight: <input type="text"/> # of Pallets: <input type="text"/> Index Table: <input type="text"/> Index Table Degrees: <input type="text"/> Auto Pallet Changer: <input type="text"/> Rotary Table: <input type="text"/> Dual Axis Rotary Table: <input type="text"/> Table Size Width: <input type="text"/> Chip To Chip Time: <input type="text"/>	
<input type="button" value="add"/>			

Figure 4.28 Define a New Machine

4.2. Summary

In this chapter, the implementation of the methodology is explained, and the developed software, its capabilities and properties are shown. First, the machine selection module based on proposed approach is explained. Then precision, reliability, cost and sensitivity analyses modules are examined with examples. Finally, other specifications of the software, machine, manufacturer and user definition, are presented.

5. CONCLUSION

Selecting the most suitable machine from the increasing number of available machines is a challenging task. Productivity, precision, flexibility, and company's responsive manufacturing capabilities all depend on the machine properties.

In this study, machine tool selection problem is addressed. First, machine tool properties are determined in order to create a machine database. Then, AHP based methodology is proposed. In order to apply this methodology, the machine properties and main and sub-decision criteria are investigated. The major contribution of this study is in combining the selection methodology based on AHP with reliability, precision, and cost analyses to evaluate several alternatives and make a good decision. In developed methodology, sensitivity analysis is also conducted in the determination of the most critical criterion and the most critical measure of performance. Cost/benefit analysis is also carried out to justify the purchase of the machine tool and its optional features. All of the methodology is demonstrated with the developed software.

The proposed methodology is very flexible in the sense that it can be applied to other types of selection problems, e.g. selection of a vehicle, hardware, appliances, etc. The uniqueness of the thesis is that decision-making, database management, expert and knowledge based systems, precision analysis, reliability analysis, sensitivity analysis, and cost analysis concepts are combined in order to solve machine selection problem.

There are limitations in developing and application of a decision support system for machine tool selection. First limitation is the lack of a standard format in machine catalogues. This complicates the classification of machine types and their properties

during construction of a machine database. Second limitation is the possible changes in the developed database. It is certain that, because of advances in technology, new machine tools with new specifications will be available soon. These limitations can be handled by a periodical update of the decision support system. Further development of the decision support system is still necessary.

In order to create decision support software, interpreted language Visual basic which means each line of the program is interpreted (converted into machine language) and executed when the program is run is used. Other languages (such as C, Pascal, FORTRAN, etc.) are compiled, meaning that the original (source) program is translated and saved into a file of machine language commands. This executable file is run instead of the source code. However, compiled languages run much faster than interpreted languages (e.g. compiled C++ is generally ten times faster than interpreted Java). The aim of this study not only constructs a machine selection methodology but also develop fast, user friendly decision software based on this methodology. Because of this the implementation language can be supported by Java.

The suggested methodology is a part of process planning. As a future work, this system may be integrated to the overall manufacturing planning system. The proposed decision methodology may also be used to select appropriate tools for machining, material handling system, robots, materials, etc. Such integration will construct an intelligent computer-assisted process planning system which enables the design and control of overall manufacturing activities

REFERENCE LIST

- [1] Altintas, Y., 2000, Manufacturing Automation, Cambridge University Press, New York, NY.
- [2] Arslan M., Çatay B., and Budak E., 2004, A Decision Support System for Machine Tool Selection, Journal of Manufacturing Technology Management, Volume 15, Number 1, 101-109.
- [3] Atmani, A. and Lashkari, R.S., 1998, A model of machine-tool selection and operation allocation in Flexible Manufacturing System, International Journal of Production Research, Volume 36, No.5, pages 1339-1349.
- [4] Belton, V., and Gear, T., 1983, On a Short-Coming of Saaty's Method of Analytic Hierarchies, Omega, pages 228-230.
- [5] Cheng E., Li H., and Ho D., 2002, Analytic Hierarchy Process (AHP), Measuring Business Excellence, Bradford, Vol. 6, Iss. 4; pg. 33, 5 pgs.
- [6] H. Oeltjenbruns, W.J. Kolarik, R. Schnadt-Kirschner, Strategic Planning in Manufacturing Systems—AHP Application to An Equipment Replacement Decision, Int. J. Prod. Econ. 38 (1995) 189- 197.
- [7] Haddock, J. and Hartshorn, T. A. , 1989, A Decision Support System for Specific Machine Selection, Computers and Industrial Engineering, Vol. 16, No. 2, pages 277-286.
- [8] Lin, Z.-C., and Yang, C.-B. , 1994, Evaluation of machine selection by the AHP method, Journal of Materials Processing Technology, Volume 57, pages 253-258.
- [9] Moon C, Lee M, Seo Y, and Lee YH., Sep 2002, Integrated Machine Tool Selection And Operation Sequencing with Capacity and Precedence Constraints Using Genetic Algorithm, Computers & Industrial Engineering, 43 (3): 605-621.

- [10] Saaty, T. L. and Vargas, L. G., 2001, *Models, Methods, Concepts & Applications of the Analytic Hierarchy Process*, Kluwer Academic Publishers, USA.
- [11] Subramaniam, V., Lee, G. K., Ramesh, T., Hong, G. S., and Wong, Y. S., 2000, *Machine Selection Rules in a Dynamic Job Shop*, *International Journal of Advanced Manufacturing Technology*, Vol. 16, pages 902-908.
- [12] Sullivan, W., Bontadelli, J. and Wicks, E., 2000, *Engineering Economy*, Prentice Hall, London.
- [13] Tabucanon, M. T., Batanov, D. N. and Verma, D. K., 1994, *Intelligent Decision Support System (DSS) for the selection process of alternative machines for Flexible Manufacturing Systems (FMS)*, *Computers in Industry*, Vol 25, and pages 131-143.
- [14] Triantaphyllou E., and Mann S., 1995, *Using The Analytic Hierarchy Process For Decision-making in Engineering Applications: Some Challenges*, *Inter'l Journal of Industrial Engineering: Applications and Practice*, Vol. 2, No. 1, pp. 35-44.
- [15] Triantaphyllou, E., 2000, *Multi-Criteria Decision-making Methods: A Comparative Study*, Kluwer Academic Publishers.
- [16] Wang, T.-Y., Shaw, C.-F., and Chen Y.-L. , 2000, *Machine Selection in flexible manufacturing cell: a fuzzy multiple attribute decision-making approach*, *International Journal of Production Research*, Volume 38, No.9, pages 2079-2097.
- [17] Yurdakul M., 2004, *AHP as A Strategic Decision-Making Tool to Justify Machine Tool Selection*, *Journal of Materials Processing Technology*, 146, 365–376.

REFERENCE LIST

- [1] Altintas, Y., 2000, Manufacturing Automation, Cambridge University Press, New York, NY.
- [2] Arslan M., Çatay B., and Budak E., 2004, A Decision Support System for Machine Tool Selection, Journal of Manufacturing Technology Management, Volume 15, Number 1, 101-109.
- [3] Atmani, A. and Lashkari, R.S., 1998, A model of machine-tool selection and operation allocation in Flexible Manufacturing System, International Journal of Production Research, Volume 36, No.5, pages 1339-1349.
- [4] Belton, V., and Gear, T., 1983, On a Short-Coming of Saaty's Method of Analytic Hierarchies, Omega, pages 228-230.
- [5] Cheng E., Li H., and Ho D., 2002, Analytic Hierarchy Process (AHP), Measuring Business Excellence, Bradford, Vol. 6, Iss. 4; pg. 33, 5 pgs.
- [6] H. Oeltjenbruns, W.J. Kolarik, R. Schnadt-Kirschner, Strategic Planning in Manufacturing Systems—AHP Application to An Equipment Replacement Decision, Int. J. Prod. Econ. 38 (1995) 189- 197.
- [7] Haddock, J. and Hartshorn, T. A. , 1989, A Decision Support System for Specific Machine Selection, Computers and Industrial Engineering, Vol. 16, No. 2, pages 277-286.
- [8] Lin, Z.-C., and Yang, C.-B. , 1994, Evaluation of machine selection by the AHP method, Journal of Materials Processing Technology, Volume 57, pages 253-258.
- [9] Moon C, Lee M, Seo Y, and Lee YH., Sep 2002, Integrated Machine Tool Selection And Operation Sequencing with Capacity and Precedence Constraints Using Genetic Algorithm, Computers & Industrial Engineering, 43 (3): 605-621.

- [10] Saaty, T. L. and Vargas, L. G., 2001, *Models, Methods, Concepts & Applications of the Analytic Hierarchy Process*, Kluwer Academic Publishers, USA.
- [11] Subramaniam, V., Lee, G. K., Ramesh, T., Hong, G. S., and Wong, Y. S., 2000, *Machine Selection Rules in a Dynamic Job Shop*, *International Journal of Advanced Manufacturing Technology*, Vol. 16, pages 902-908.
- [12] Sullivan, W., Bontadelli, J. and Wicks, E., 2000, *Engineering Economy*, Prentice Hall, London.
- [13] Tabucanon, M. T., Batanov, D. N. and Verma, D. K., 1994, *Intelligent Decision Support System (DSS) for the selection process of alternative machines for Flexible Manufacturing Systems (FMS)*, *Computers in Industry*, Vol 25, and pages 131-143.
- [14] Triantaphyllou E., and Mann S., 1995, *Using The Analytic Hierarchy Process For Decision-making in Engineering Applications: Some Challenges*, *Inter'l Journal of Industrial Engineering: Applications and Practice*, Vol. 2, No. 1, pp. 35-44.
- [15] Triantaphyllou, E., 2000, *Multi-Criteria Decision-making Methods: A Comparative Study*, Kluwer Academic Publishers.
- [16] Wang, T.-Y., Shaw, C.-F., and Chen Y.-L. , 2000, *Machine Selection in flexible manufacturing cell: a fuzzy multiple attribute decision-making approach*, *International Journal of Production Research*, Volume 38, No.9, pages 2079-2097.
- [17] Yurdakul M., 2004, *AHP as A Strategic Decision-Making Tool to Justify Machine Tool Selection*, *Journal of Materials Processing Technology*, 146, 365–376.