

This is an author produced version of a paper published in International Journal of Forest Engineering. This paper has been peer-reviewed and is proof-corrected, but does not include the journal pagination.

Citation for the published paper:

Lindroos, O., Gullberg, T. & Nordfjell, T. (2007) Torques from Manual Tools for Directional Tree Felling. *International Journal of Forest Engineering*. Volume: 18 Number: 2, pp 40-51.

<http://journals.hil.unb.ca/index.php/IJFE/article/view/5710>

Access to the published version may require journal subscription.  
Published with permission from: Forest Products Society



Epsilon Open Archive <http://epsilon.slu.se>

# Torques from Manual Tools for Directional Tree Felling

Ola Lindroos<sup>1</sup>, Tomas Gullberg<sup>2</sup> and Tomas Nordfjell<sup>1</sup>

<sup>1</sup>Department of Forest Resource Management, Swedish University of Agricultural Sciences, Sweden

<sup>2</sup>School of Industrial leadership, Dalarna University, Sweden

Published 2007 in *International Journal of Forest Engineering* 18(2), 40-51.

## Abstract

Motor-manual tree felling is commonly practiced in many regions of the world. Trees falling in unwanted directions cause severe accidents and extra work in motor-manual logging. Different kinds of manual tools can help force trees to fall in the desired direction, but their capacity are uncertain due to a lack of suitable evaluation methods. Reliable recommendations of felling tools' limits could help reduce human injuries and damage to property. The objective of this study was, therefore, to develop and evaluate a realistic and convenient method for studying felling tools' capacity in terms of the potential torque they can generate. A theoretical model of torque components was constructed and the mechanics of the falling tree and of the studied equipment were explained. The developed method uses real trees, which were cut at 1.65 m above stump height to create trial stems. Trial stems were anchored to a neighboring tree and then cut as if they were to be felled. Standardized forces were applied to a forestry jack, felling lever, and wedge, and their effects on the trial stem were recorded by a load cell in the anchoring line. The method proved suitable for the evaluation of forestry jacks, while it needs improvements to evaluate felling levers and wedges thoroughly. Methodological improvements are suggested and practical applications are discussed and demonstrated in terms of the forestry jack's capacity to deal with trees with unfavorable angles of inclination.

*Keywords:* Force, tree felling, forestry jack, felling lever, wedge, method development, experimental study.

## Introduction

### Background

Motor-manual tree felling is commonly practiced in many regions of the world. Even in regions with a high level of mechanized forest operations, chainsaws are used where conditions are unsuitable for mechanized work, e.g. in cases where the terrain is steep or trees with very large diameters are being cut (Nordfjell et al. 2004, Silversides and Sundberg 1989). Motor-manual operations also have clear advantages over highly mechanized operations in cases where budgetary constraints on capital investments are tight (Nordfjell et al. 2004, Silversides and Sundberg 1989). Even in Sweden, where the forestry industry is highly mechanized there are approximately 127,000 private owners who cut their trees motor-manually (Lindroos et al. 2005). Compared to global conditions, trees in the Swedish forest are small; trees with a breast height diameter on bark greater than 44 cm only account for 3% of the standing volume (National Board of Forestry 2000) and most of the trees are less than 25 m tall

(Ager et al. 1964). Nevertheless, falling trees cause fatal accidents. During the last 30 years, at least 217 fatal accidents have occurred in Swedish forestry (National Board of Forestry 1994, 2000, 2006), half of which occurred when trees were felled with chainsaws (National Board of Forestry 2000, 2006, Thelin 2002). Mechanization of industrial forestry has decreased the rates of fatal accidents by 50% (Axelsson 1998) and nowadays most casualties are private forest owners, amongst whom fatalities have remained at a constant 10 per year (Axelsson 1998, Thelin 2002). In addition, private forest owners suffer a large amount of non-fatal accidents (Engsås 1993, Wilhelmson et al. 2005). Especially unpredictable direction in which trees fall is a main contributor to both severe and fatal accidents (Gustafsson et al. 1970) and to lodged trees. The work required to bring lodged trees to the ground both reduces productivity and is hazardous (ILO 1998, Koroleff 1947).

The basic principles for safe, directional tree felling are well-established, and were developed long before the advent of the chainsaw (c.f. Fredenberg

1892). Irrespective of whether trees are being cut manually or motor-manually, several recommended cutting features have remained (Anon. 1947, Hache 1954, Husqvarna 2003), even if the terminology varies. These general features are an open notch, a felling cut and a residual wood strip between the two cuts (Fig. 1). The felling cut and the bottom of the notch are assumed to be level with each other in this article, although the spatial relationships between them inevitably vary somewhat. The residual wood strip, which has been given many different names (e.g. bridge (Koroleff 1947), holding wood (Conway 1978, Guimier 1980, Härkönen 1978), key (Brunberg et al. 1984) and breaking crest (Staafl and Wiksten 1984)) is called the hinge (FAO 1980, ILO 1998) in this paper, since the term reflects its main function. Recommended dimensions for all of these cutting features are far from uniform. The recommended thickness of the hinge ranges from a minimum of 1 cm to a relative measure of 10% of the tree's diameter at stump height on bark (dsh ob) (Anon. 1947, Husqvarna 2003, Härkönen 1978), while the recommended dimensions of the notch's depth and opening angle range from 10% to 33% of the tree's dsh ob (Anon. 1947, Conway 1978, Koroleff 1947) and from 27° to 90°, respectively (Anon. 1947, Brunberg et al. 1984).

The location of a tree's center of gravity depends on its height, biomass distribution, natural inclination and external factors such as snowload. A tree's natural felling direction is dependent on the position of its center of gravity relative to the centre of the stump. The wind may also influence the natural felling direction. If the tree can be felled in its natural felling direction, it often falls as soon as the felling cut is deep enough. However, due to various factors, including the locations of other trees, the terrain or extraction plans, other felling directions are frequently desired and the tree will thus have to be forced to fall as desired (Koroleff 1947). Since the hinge is not located in the vertical center of the stem, the gravitational force acting through the centre of gravity of even a completely straight tree and the hinge's bending resistance will counteract movement in the intended falling direction and additional force will be required to overcome them. The fall will proceed without added force if the center of gravity is sufficiently far towards the notch side of the hinge. An attempt to tip over a tree with insufficient force will result in the stem leaning, but it will return to its original position when the force is removed, because when low levels of stress are applied to the hinge for short periods of time, deformation of the wood can be described as elastic and thus follows Hooke's law (Dinwoodie 2000). The law states that stress is proportional to strain but

independent of the rate of strain, meaning that the material will regain its original shape when the stress is removed, as long as the stress is lower than the material's yield point (Timoshenko and Goodier 1970).

### Human force and felling tools

Although pushing by hand sometimes can force a tree to fall, the action can result in back strain injuries (Härkönen 1978). To prevent strain injuries and trees falling in unwanted directions, various tools have been developed for safe, controlled felling. Tools such as forestry jacks, felling levers and wedges (Fig. 3-5) all augment human force inputs, but have different working principles. Felling levers and wedges are inserted into the felling cut, while forestry jacks apply force to the stem above the felling cut. Within each of the three categories, there are several varieties. With a forestry jack, force is exerted by anchoring the tool (usually to the ground), attaching it to the tree and then extending the parts between the anchoring point and the tree by means of a winch or rack gearing (Lindroos 2004). The length of the felling levers varies and they can be either pulled by hand or pushed by foot. The mean maximum forces males can exert has been found to be approximately 440 N for standing horizontal hand pushing (Koroleff 1947, Van Kott and Kinkade 1972) and 1,200 N for leglifting (Guimier 1980), which are actions required when operating common types of forestry jacks and felling levers, respectively. Wedges mainly have fixed angles and sizes, but there are also extending wedges which work as jacks in the felling cut and are operated pneumatically or mechanically. Use of wedges involves a hitting action, the generated force being dependent on both the human force applied and the hitting tool's mass. Usually, axes and sled-gehammers are used as hitting tools. Kinetic energies of 167-296 J have been recorded when splitting wood by vertical hitting, using axes with masses between 1.4-2.8 kg and axe velocities of 13.8-14.0 m s<sup>-1</sup> (Widule et al. 1978). Previously, levers were commonly used by private forest owners in Sweden (Blom et al. 1973, Friberg et al. 1974, Gårdh 1974), and felling tools are still believed to be frequently used, but there is little reliable information to support this belief.

### Aim of the study

There is considerable uncertainty regarding felling tools' capacity to force trees to fall, due to the great natural variation in tree features (e.g. size, crown shape and leaning) and other relevant factors (e.g. proportions of felling features, wind and snow load). Reliable recommendations of felling tools' limits

are believed to help reduce both human injuries and damage to property. Theoretical knowledge of the felling tools' forces is well established and felling levers have been evaluated in several studies. The forces they generate have been explored in experimental indoor studies (Takalo 1982, Wikberg 1992) and models for predicting the generated forces based on theoretical assumptions (Carlsson 1997, Guimier 1980, Takalo 1982) have been constructed. However, there is a lack of suitable methods for testing theoretical assumptions and validating models under realistic conditions. In order to develop such a method, a theoretical model of torque components have to be constructed and the mechanics of the falling tree and the analyzed equipment have to be mathematically described. This article focuses on the initial part of the falling action, i.e. the work required to make the tree topple over. The mechanics of the subsequent fall are described elsewhere (e.g. Guimier 1980, Mikleš and Záchenský 1995).

The objective of this study was to develop and evaluate a realistic and convenient method to study felling tools' capacities in terms of the potential torque they can generate. This was done through repetitive tests on tree stems.

Theoretically, some stem movement is essential in such tests, to enable measurements to be taken, but the movement should be kept to a minimum to avoid (or at least minimize) destruction of the wood in the hinge, and thus increase the system's durability with respect to repeated testing. It was hypothesized that the testing procedures to be applied would keep the stresses on the hinge below its yield points and thus enables repeated testing.

### Mechanics of the falling tree

The general mechanics of the tree is modeled as a rigid body that is rotated around a fulcrum, located in the middle of the hinge ( $P_F$  in Fig. 2). The modeled motion takes place in a vertical plane, does not include any sideways movements and ignores several factors of importance, e.g. the tree's natural inclination and wind (Carlsson 1997, Guimier 1980, Takalo 1982). The distance between  $P_F$  and the force vectors involved are called levers and the product of a force and its lever results in a torque around the fulcrum. The tree's motion causes changes in levers that depend on the leaning angle ( $\alpha$ ) around  $P_F$ . A point ( $P_A$ ) is moved vertically as well as horizontally during the initial phase of the felling (Fig. 2). At a given  $\alpha$ , the point has been moved to  $P'_A$ . The vertical lever  $h_A$  between  $P_F$  and  $P_A$  is consequently transformed to  $h'_A$  and correspondingly the horizontal lever  $L_A$  is transformed to  $L'_A$  (Fig. 2).  $h'_A$  and  $L'_A$  are calculated from equa-

tions 1 and 2, respectively. Hereafter  $P_A$  will represent the point of application of a force.

$$h'_A = \cos(\alpha) \times h_A + \sin(\alpha) \times L_A \quad (1)$$

$$L'_A = \cos(\alpha) \times L_A - \sin(\alpha) \times h_A \quad (2)$$

### Mechanics of the forestry jack

The forestry jack is attached to the stem and a solid support, normally the ground. By extending the tool, force is applied through the two supporting ends. The tool's input force ( $F_I$ ) (Fig. 3) is the product of cranking force and the tool's transmission. The input torque ( $M_I$ ), which affects the tree, is determined by  $F_I$  and the distance to  $P_F$  (Fig. 3). Initially  $F_I$  affects the tree at the application point  $P_A$ , and when  $\alpha > 0$  at  $P'_A$  (c.f. Figs. 2 and 3).  $F_I$ 's vertical and horizontal components ( $F_{IY}$  and  $F_{IX}$ , respectively) are dependent on the angle of application ( $\varphi$ ) according to

$$F_{IY} = F_I \times \sin(\varphi) \quad (3)$$

$$F_{IX} = F_I \times \cos(\varphi) \quad (4)$$

The levers of  $F_{IY}$  and  $F_{IX}$  at a given  $\alpha$  ( $L'_A$  and  $h'_A$ , respectively, cf. Fig. 2) are computed from equations 1 and 2, while the input torque ( $M_I$ ) is determined according to equation 5 (c.f. Fig. 2 and 3).

$$M_I = F_{IY} \times L_A + F_{IX} \times h_A \quad \text{or when } \alpha > 0: \quad (5)$$

$$M_I = F_{IY} \times L'_A + F_{IX} \times h'_A$$

### Mechanics of the felling lever

When a felling lever is used, part of the tool (the tongue) is inserted into the felling cut (Fig. 4), hence  $h_A = 0$ . As its name implies, the tool transmits a force according to the laws governing levers. The felling lever is lifted vertically and the lifting force ( $F_L$ ) corresponds to  $F_{IY}$ , the vertical component of the input force ( $F_I$ ) affecting the stem, according to Eq. 6. An underlying assumption of the equation is that there is no wood deformation in the felling cut.

$$F_{IY} = F_{LY} \times L_L \times L_T^{-1} \quad (6)$$

$L_L$  is the lifting lever and  $L_T$  is the tongue lever (Fig. 4A). The relation between  $L_L$  and  $L_T$  determines the force transmitted by the tool. As the tree starts to lean, the relationship between the tool's levers changes (Fig. 4) and thus affects the input torque ( $M_I$ ). At a given tree leaning angle  $\alpha$ , the application point of  $F_I$  has moved from  $P_A$  to  $P'_A$ . The felling lever itself has rotated more than the tree, around the

tool's fulcrum ( $P_{FL}$ , located at the tip of the tool's tongue) with a rotation angle  $\beta$  according to

$$\beta = \arcsin(h'_A \times L_T^{-1}) \quad (7)$$

where  $h'_A$  is calculated from Eq. 1 with  $h_A = 0$ . In order to follow the tree's rotation,  $P_{FL}$  must move to  $P'_{FL}$  (away from  $P_F$ ) during the action (Fig. 4B). Hence,  $L_T$  and  $L_L$  are transformed to  $L'_T$  and  $L'_L$ , respectively. The tool's lever transformations are dependent on  $\beta$  and  $h_L$ , respectively, according to equations 8 and 9, where  $h_L$  is the vertical distance between  $P_A$  and the point on the felling lever where  $F_L$  is applied (at  $\alpha=0$ ).

$$L'_T = \cos(\beta) \times L_T \quad (8)$$

$$L'_L = L_L \times \cos(\beta) - \sin(\beta) \times h_L \quad (9)$$

In the initial phase of the lift, when no change in the stem's angle of inclination has occurred (Fig. 4A,  $\alpha = 0$ ),  $F_{IY}$  alone constitutes the stem-affecting force  $F_I$ . When the stem is leaning at an angle  $\alpha$ ,  $F_{IY}$  can be calculated from Eq. 6 after replacing  $L_L$  and  $L_T$  by  $L'_L$  and  $L'_T$ , respectively. In addition, stem lean adds a horizontal component ( $F_{IX}$ ) to the input force ( $F_I$ ) (Fig. 4B). The horizontal component is dependent on  $F_{IY}$  and  $\beta$ , according to Eq. 10.

$$F_{IX} = F_{IY} \times \tan(\beta) \quad (10)$$

At a given  $\alpha$ , the levers of  $F_{IY}$  and  $F_{IX}$  ( $h'_A$  and  $L'_A$ , respectively) are determined according to Eqs. 1 and 2, while the felling lever's input torque ( $M_I$ ) can be calculated from Eq. 5.

### Mechanics of the Wedge

A felling wedge is driven into the felling cut by a force generated by an object with a certain kinetic energy ( $W_K$ ) that is dependent on the object's speed and mass. Transmission of the energy results in a force that drives the wedge into the felling cut and thus lifts the tree (Fig. 5). The driving force is dependent on the friction between the wedge and the wood, and on the tree's mass, which collectively determine the wedge's resistance to forward movement. The lifting force is dependent on the relationship between the wedge's length and height, which can be described as the wedge angle  $\lambda$  (Fig. 5). A small  $\lambda$  gives a high lifting force, but may lift the tree insufficiently to cause the tree to fall. Furthermore,  $\lambda$  affects the direction of  $F_I$  and thus the vertical and horizontal components  $F_{IY}$  and  $F_{IX}$ . At  $h_A = 0$ ,  $F_{IX}$  does not substantially contribute to the input torque ( $M_I$ ), but might stress the hinge at high friction. When the wedge is forced into the felling cut,

the tree starts to lean. As for the felling lever, the application point ( $P_A$ ) for the input force ( $F_I$ ) is moved to  $P'_A$  at a leaning angle  $\alpha$  (cf. Fig. 4B) when assuming that there is no wood deformation in the felling cut. In the use of a wedge,  $\alpha$  is dependent on  $\lambda$  and the distance the wedge has been driven into the felling cut. Unless the tree starts to tip over due to the wedge being driven in,  $\alpha$  can never be larger than  $\lambda$ .

### Theoretical model of torque components

All the forces that affect the tree in the felling process can be described by a torque equation, and the torque from the tool (the input torque, ( $M_I$ )) needs to exceed the counteracting torques to cause stem movements. The surplus torque ( $M_E$ ) that causes movements can be expressed as

$$M_E = M_I - M_M - M_B - M_D - e \quad (11)$$

where  $M_M$  is the torque resulting from the tree's mass and is calculated from Eq. 12.  $M_B$  is the hinge's bending resistance,  $M_D$  includes friction and deformation of the wood in contact with the tool and  $e$  is the random error.

$$M_M = F_M \times L_{AM} \quad (12)$$

$F_M$  is the force generated by the tree's weight and  $L_{AM}$  is the horizontal lever of  $F_M$  (cf. Fig. 6). The effect of the stem's movement on  $L_{AM}$  is calculated using Eq. 2, with  $L_A$  substituted for  $L_{AM}$ .

## MATERIAL AND METHODS

### Developed method

Trees of two diameter on bark at stump height (dsh ob), 20 cm and 35 cm, were included to provide indications of the effects of the trees' diameters on the forces and torques generated by the tools. Trees were cut by chainsaw at 1.65 m above the planned felling cut, to exclude possible bias from the trees' crown shape and wind.

A chainsaw with a 50 cm guide bar was used to make notch and felling cuts, the latter with a height of 8 mm. A spirit level was used to ensure that the felling cut and the bottom of the notch were horizontal and level with each other. Notches and hinges of the desired depth and thickness, respectively, were created using a caliper-shaped tool, which indicated the correct dimensions. The notch angle was set to 60°, hence the notch depth and height were 20% and 35% of the dsh ob, respectively. The hinge thickness was set to 12.5% of the dsh ob (cf. Fig. 1). The remaining part of the tree above the

felling cut is hereafter referred to as the trial stem, and the part below it as the stump (Fig. 6).

The trial stems were horizontally attached to a neighboring tree by an anchoring line at 180° to the felling direction (Fig. 6). The anchoring line consisted of slings placed around the stems 1.6 m above the felling cut and tightened by ratchet straps. The slings and straps were made of polyester and had a loading capacity of 20 kN. Between the sling and strap, a Bofors 10 kN load cell (model KRG4) was placed to record forces. The force was amplified by a Bofors Amplifier (model BKF-1) and digitally displayed on a Caltek CM2701 Multimeter. Electricity for the measuring equipment was supplied by a portable petrol-driven generator. The instruments were electrically calibrated continuously during the study, complemented with calibration measurements before and after the study. Surplus torque ( $M_E$ ) was used as the response variable in data analysis, and was calculated according to

$$M_E = (F_E - F_{AL}) \times h_{AE} \quad (13)$$

where  $F_E$  is the recorded force,  $F_{AL}$  is the initial force in the anchoring line.  $h_{AE}$  is the anchoring line's attachment height above the felling cut (Fig. 6), and as a lever to  $P_F$  it was compensated for lean according to Eq. 1. The initial anchoring line force was 170 N prior to each tool trial and the force was released between trials. Trial stem movements were recorded by the use of an inclinometer attached to the stem.

Aspects of the method applied here resemble those applied in simulations presented by Koroleff (1947) of the effects of pushing trees by hand and poles. However, in the method presented here, real trees are used in the forest.

### Tree and trial stem features

The study was conducted during October 2003 on unfrozen Scots pine trees (*Pinus sylvestris*) in two adjacent stands in Northern Sweden (63°57'N, 20°23'E, 75 m above sea level). The site index of both stands, expressed as expected dominant height at an age of 100 years (Hägglund and Lundmark 1987), was estimated to be 22 m for Scots pine. At the start of the study the trees in the 20 cm and 35 cm classes had mean heights of 15.6 m (standard deviation (SD) 1.2 m) and 20.5 m (SD 1.9 m), respectively, and were 55 (SD 2 years) and 80 (SD 21 years) years old, respectively, according to counts of annual rings in the stumps. The bottom of the notch was 2.6 mm (SD 7.8 mm) and 9.2 mm (SD 15.3 mm) above the felling cut for the 20 cm and 35 cm classes, respectively. Mean values for other variables of the trial stems are presented in Table 1.

General linear model analysis (see *Statistical analyses*, below) showed that trial stem features within diameter classes did not vary significantly between tool orders. Trial stems' masses were recorded directly after the tests. Wood samples were taken 3.0 cm (SD 0.9 cm) and 6.5 cm (SD 1.1 cm) above the hinge from the trees in the 20 cm and 35 cm diameter classes, respectively. Wood samples were analyzed for dry wood density and moisture content, by weighing them, drying them at 105°C to constant mass, re-weighing them and then determining their volumes from their buoyancy, i.e. the difference between their absolute weight and weight when submerged in water.

### Studied felling tools

The studied tools were one model, respectively, of forestry jack, felling lever, and wedge. For each tool, standardized forces were applied consecutively without releasing the anchoring line's tension. All tools were applied 180° to the felling direction.

The forestry jack used was a Stalpen (Gränsfors Bruks AB, Sweden), which had an initial length of 1.85 m and could be extended to 2.45 m. It had a rack gearing transmission system and its mass was 14.5 kg. The tool's crank handle axis was turned with a calibrated torque wrench to 51.1, 72.2 and 95.5 Nm, corresponding to cranking forces ( $F_C$  in Fig. 3) of 255, 360 and 478 N, respectively, if the jack's 0.20 m long cranking handle had been used. The applied torques resulted in input forces ( $F_i$ , Fig. 3) of 7,014, 9,910 and 13,108 N, respectively, assuming full transmission efficiency. The tool's application angle ( $\varphi$  in Fig. 3) was 45°. The height of the application point above the felling cut ( $h_A$  in Fig. 3) ranged from 0.64 m to 1.18 m, since it was impossible to keep height constant due to variations in ground level.

The felling lever used was a Bahco 1010 lifting lever (Bahco AB, Sweden). The estimated application point ( $P_A$ ) for the force applied to the trial stem was set as far away from the tool's fulcrum ( $P_{FL}$ ) as possible. Thus, the tool's full tongue length of 0.053 m formed the tongue lever ( $L_T$ ) (c.f. Fig. 4). The relation between the lifting lever's ( $L_L$ ) length of 0.648 m and  $L_T$  gave an initial transmission (when  $\alpha=0$ , c.f. Fig. 4) of 12.2 times the applied force.  $h_L$ , the vertical distance between the applied force and  $P_A$ , was 0.225 m. The tool's mass was 1.3 kg. Lifting forces ( $F_L$  in Fig. 4) of 490, 740, 980 and 1230 N were applied to the felling lever by a manual winch hanging from a tripod (Fig. 6). The vertical lifting force was controlled by a Bofors 5 kN load cell (model KRG 4) connected to a Bofors BKI-4 amplifier.

The wedge used was a Bahco 6300 nylon wedge (Bahco AB, Sweden), which was used with its serrated ridge on the upper side. The wedge was 0.044 m wide and 0.021 m high ( $h_w$  in Fig. 5). The distance from the tip to the highest point of the wedge ( $L_w$ , Fig. 5) was 0.109 m, while its total length was 0.121 m. The wedge angle ( $\lambda$ ) was  $11^\circ$  and the wedge's mass was 0.070 kg. The wedge was hit 14 times consecutively by a flat-faced pendulum dropped perpendicular to the hitting point (Fig. 6). The mass of the pendulum used was two kg for the first seven hits and five kg for the following seven hits. The pendulum's 1 m swing arm was dropped from a horizontal position such that it was vertical when hitting the wedge, at a speed of  $4.4 \text{ m s}^{-1}$ , assuming the pendulum friction to be zero. Consequently, the wedge was hit with an estimated kinetic energy of 19.6 J seven times and 49.1 J the following seven times. The force value observed approximately 5 seconds after the hit was recorded. To include the change in pendulum mass, cumulative hit energy was used to signify the independent variable of applied force.

### Statistical analyses

Twenty-one trees were randomly chosen to represent each of the two stump diameter classes, and seven trees were randomly chosen from each of the two classes for each of the tool orders JLW, LWJ and WJL, where J, L and W denote forestry jack, felling lever and wedge, respectively. This intermix design enabled each tool to be studied as first, second and third treatments an equal number of times. The applied forces on each tool were the same for both diameter classes and all tool orders. The method used to analyze effects of treatments for a specific tool was Analysis of Variance (ANOVA), based on the model:

$$y_{klmr} = \mu + \gamma_m + \beta_l + (\gamma\beta)_{lm} + \alpha_k + (\alpha\gamma)_{km} + (\alpha\beta)_{kl} + (\gamma\alpha\beta)_{mkl} + c_{r(km)} + e_{lr(km)}$$

where  $y_{klmr}$  is the response variable (surplus torque,  $M_E$ ),  $\mu$  is the grand mean,  $\gamma_m$  is the fixed effect of diameter,  $\beta_l$  is the fixed effect of applied force,  $\alpha_k$  is the fixed effect of tool order,  $c_{r(km)}$  is the random effect of tree, nested within diameter and tool order, and  $e_{lr(km)}$  is the random error. The model also contains the four fixed interaction effects  $(\gamma\beta)_{lm}$ ,  $(\alpha\gamma)_{km}$ ,  $(\alpha\beta)_{kl}$  and  $(\gamma\alpha\beta)_{mkl}$ . To analyze effects of treatments within a specific tool and tool order, the model (Eq. 14) was used with  $\alpha_k$  and all its related interaction effects removed. Stem feature differences between tool orders were evaluated using the model (Eq. 14) with  $\beta_l$  and all its related interaction effects removed. A general linear model (GLM) was used for analyzing the ANOVA models (Minitab 14, Minitab

Ltd.). Relations between input torques compensated for lean according to Eqs. 1-10 and recorded surplus torque (Eq. 13) were analyzed by linear regression within trees. Differences between regression equations were analyzed with F-tests. Results of statistical analyses were considered significant if  $p \leq 0.05$ .

## RESULTS

### Surplus torque

The order of tool application on trial stems ( $n=21$  per diameter and tool) had a significant effect on the recorded surplus torque ( $M_E$ , Eq. 13) for the lever and wedge ( $p = 0.000$ ), but not for the jack ( $p=0.212$ ). Surplus torques for the wedge and lever were 0.4-3.8 times higher when tested after the forestry jack. The maximum leaning angle ( $\alpha$  in Fig. 2) of a trial stem was  $8.5^\circ$ . Large differences in this respect were recorded between tools, with the largest angle for the jack and the smallest for the lever, as well as between diameters; trees of the smaller diameter class having the largest angles.

Due to the effect of tool order, only results from trial stems on which each tool were studied first were analyzed further ( $n=7$  per diameter and tool). For those trial stems, both diameter and level of applied force had significant effects on recorded torque for all tools ( $p \leq 0.044$ ). For the lever and wedge there were significant interaction effects between diameter and applied force ( $p \leq 0.007$ ). The individual trees had a significant effect on the recorded surplus torque for all tools ( $p=0.000$ ).

To incorporate the effect of the leaning of the trial stems on the recorded surplus torque ( $M_E$ , Eq. 13), equations 1-11 were used, resulting in a range of input torques due to the variations in force levers. Unsurprisingly, for all tools, the ratio between surplus torque and input torque was lower for trees of the larger diameter class than for the smaller trees (Figs. 7 and 8). In figure 7, the components in the torque equation (Eq. 11) are presented as ratios of the input torque ( $M_I$ ) for each force applied to the forestry jack and felling lever. The hinge's bending resistance ( $M_B$ ), friction and deformation ( $M_D$ ) and random error collectively account for the rest of the total force in each case. The  $M_E$  ratios for the forestry jack indicate that its efficiency increased substantially as the applied force ( $M_I$ ) was increased in tests with trees in the 35 cm diameter class, but this variable had relatively little effect in tests with trees in the 20 cm class. The patterns of between-tool differences in the effects of leaning angle and tree diameter were similar to those previously described for tests in which each tool was studied first (Fig. 7).

For the highest cumulative hit energy applied to the wedge (481 J),  $M_E$  and  $M_M$  summed to 927 Nm (SD 218 Nm) and 546 Nm (SD 198 Nm) in tests with trees in the 20 and 35 cm diameter classes, respectively.

Within trees, the correlation between input torque ( $M_I$ ) and recorded surplus torque ( $M_E$ , Eq. 13) was linear (Fig. 8). For the forestry jack, the regression slopes for the 14 test trees in the two diameter classes were not significantly different ( $p=0.477$ ) and the intercepts between trees were not significantly different within diameter classes ( $p>0.128$ ). Regression lines for individual trees for the other tools differed both between trees and between diameter classes (Fig. 8). The orders of individual tree's regression lines were not obviously correlated to differences in hinge features, wood density or tree age.

## DISCUSSION

### Internal validity

The results of the study show that individual trees with a given diameter were homogenous enough to provide consistent testing material. This conclusion is supported by the uniform linear relation between input torque and surplus torque for trees that were tested first by the forestry jack (Fig. 8). Small variations in linear relations were found, and are believed to reflect the difficulties in computing the torque interactions rather than indicating substantial variations in the test material. The felling lever and wedge both operated in the felling cut, and the torques recorded for them differed between individual trees. For the felling lever, differences were probably mainly due to its complex leverage interactions with tree leaning (cf. Eq. 6-10), which are further discussed below. For the wedge, however, the fan-shaped pattern in Fig. 8 indicates that the between-tree differences between input and surplus torque were much more constant, and probably mainly due to variations in friction between the wedge and the wood. The results suggest that friction-affecting factors, such as chain oil from the chain saw and frozen wood, should be controlled in future studies.

The evaluated method was not suited for repeated measurements of felling tools' torque on the same trial stem. Stem leaning movements ( $\alpha > 1^\circ$ ; cf. Fig. 2) caused differences in subsequent tests, probably due to hinge wood destruction. For the forestry jack more material could have been used ( $n=21$  per diameter class) in the evaluation. However, that possibility was not pursued partly because it was believed that the lack of a tool order effect in this case was masked by the jack's higher torque level com-

pared to that of the other tools and partly to ensure consistency in the methodology evaluation. To some extent destruction probably also affected the evaluation of different applied forces for the tools that were applied first to the trial stems. The felling lever parameters seemed to be especially sensitive to stem leaning movements, which is not surprising since even small movements and wood deformations cause large changes in its force transmission and thus changes in the input torque. In practical tree felling, the movements and elasticity of the stem are well known (and exploited) phenomena. A tree that cannot be tipped over directly can often be swayed until it falls. The swaying causes both a build up of kinetic energy and, as the results indicate, destruction of hinge wood, both of which reduce resistance. Thus, if movement and elasticity variables were fully integrated in the method, even more realistic conditions could be achieved. The movements in the study derived from the anchoring line's inherent elasticity and elasticity in the anchoring tree. To decrease the latter the stability of the anchor trees should be reinforced in further studies. In addition, a higher initial tension force would make the anchoring more static, and thus improve the method's suitability for repeated measurements, at least when testing tools that develop similar torque levels. However, the levels applied in this study tallied with the expected tension from real trees. Other aspects of initial tension force in the anchoring line are considered below.

Concerning trial stems' felling features, the vertical relationship between felling cut and bottom of the notch varied somewhat in the study due to free hand sawing. In the analysis the two cuts were, however, considered to be level with each other for practical reasons. This discrepancy could influence the torque calculations and should benefit from future research.

For the wedge, the applied kinetic energy (the cumulative hit energy) was known, while the input torque ( $M_I$  in Fig. 5) was not quantified. However, the sum of the recorded torque and mass torque provide an indication of the minimum  $M_I$  value that the cumulative hit energy generated, based on Eq. 11, in accordance with which additional torque is required to overcome the hinge's bending resistance ( $M_B$ ), deformation ( $M_D$ ) and random errors. The applied energy was 6-8.5 times lower in this study compared to previous studies on the kinetic energy in axe strikes (Widule et al. 1978). It is, however, doubtful that all of the energy from an axe strike intended to split wood could be used in the work of hitting a wedge, due to the differences in swing and aiming factors. Nevertheless, trials intended to provide realistic tests for wedges would need to further consider the applied energy.



To fully understand the potentials of the felling tools, it is necessary to understand the mechanics of the falling tree as well as those of the tools. For the felling lever, an important issue to address is the point of application of the input force along the felling lever's tongue. Use of the full tongue length as the lever minimizes the input force and thus prevents over-estimations. If the application point of the input force is moved from the tongue's full length to its middle, the resulting halving of the tongue lever would theoretically double the input force when  $\alpha=0$ . In the input torque calculations (Eq. 5), the stump lever ( $L_A$ ) would consequently decrease, but normally far from enough to compensate for the increased input force. It is quite possible that the input force's point of application on the tongue changes as the stem leans. Furthermore, at a very low stem leaning angle ( $\alpha$ ), the tongue lever is likely to exert pressure over an area rather than at a discrete fulcrum ( $P_A$  and  $P_{FL}$  in Fig. 4). Consequently, assumptions regarding the input force's properties can substantially affect the torque equation's outcome in terms of the tool's efficiency. Nevertheless, the presented method enables surplus torque development in relation to human input to be evaluated despite the uncertainties regarding input torque.

#### External validity

The surplus torque recorded in this study for the felling lever in tests with trees in the 20 cm class was 3 % higher to 19% lower compared to torques derived from results presented by Wikberg (1992). Wikberg studied the forces generated by three felling levers applied to fresh birch (*Betula sp.*) wood plates with a hinge thickness of 0.020 m, but did not present any torque calculations or consider the effects of tree diameter and hinge thickness. In comparison to results presented in a study in which felling levers were pressed on metal, and thus the effects of hinge resistance and deformations were excluded (Takalo 1982), the current study's values were, as expected, much (>63%) lower. From Wikberg's data, Carlsson (1997) computed that there was a 30% deficit compared to theoretical values, which was ascribed to wood deformation and friction between the lifting tongue and the wood. The corresponding deficits in the present study were similar for the 20 cm class (>32%), but much higher (>72%) for the 35 cm class and dependent on the applied force (Fig. 7). Consequently, the deficits are dependent on the tree's diameter (and thus hinge features) and applied force. The latter conclusion is not surprising, since the current study allowed a certain level of stem movement and thus work associated with bending the hinge.

#### Tools' capacity

According to Eq. 11, the only additional variable that needs to be accounted for to calculate the recorded surplus torque's sufficiency in the work to fell a real tree is the torque generated by the tree's mass. Given the study's cutting feature proportions, the mass of a straight Scots pine with a dsh ob of 35 cm requires 490 Nm (derived from Ager et al. (1964)) to be pushed over. The corresponding torque for a tree with a dsh ob of 20 cm is 79 Nm. The surplus torque's sufficiency can then be calculated using our data and model by deducing the trial stem's mass and adding the tree's theoretical mass torque. The forestry jack gave the most consistent results and is used as an example in Fig. 9, which addresses the initial part of the felling process ( $\alpha=0$ ). In the left part of the figure the tool's efficiency is plotted as the two diameter classes' regression functions from Fig. 8 with the theoretical tree mass torques added to the constants. The right hand side of the figure shows how the surplus torque can be assessed for its capacity to deal with factors that counteract the desired felling direction. Possible factors are e.g. wind, snowload and, as illustrated in Fig. 9, leaning in an opposite direction to the desired felling direction. With a maximum human input force of 0.44 kN (Koroleff 1947, Van Kott and Kinkade 1972) on the forestry jack handle, the input torque for a tree of 35 cm dsh ob is 10.5 kNm according to Eqs. 3-5 with tree features as in Table 1. The input torque level is more than sufficient to overcome the hinge's bending resistance, tree's mass torque, friction and deformation, resulting in a torque surplus of almost 5 kNm. This surplus would be sufficient to fell Scots pines trees with unfavorable natural angles of inclination up to almost 7 degrees (thin dotted line in Fig. 9). Comparing the tensile strength parallel to the grain in fresh wood (Anon. 1999) with the tensile stress from the tree's mass, the hinge would cope with this lean without being pulled apart. A similar input force for a Scots pine with a dsh ob of 20 cm would result in a surplus of some 8.5 kNm, which would be sufficient to counter any possible tree lean opposite to the desired felling direction. For the felling lever, the study's highest applied force of 1,230 N matched the maximum human lifting force (Van Kott and Kinkade 1972). After deducting theoretical tree mass torques from the 20 cm and 35 cm diameter classes' mean recorded surplus torques, the remaining 0.8 kNm and 0.7 kNm would suffice for trees leaning by 5° and 1°, respectively. The wedge is strongly affected by the real tree's mass, so analysis of the current study's results in terms of capacity for leaning trees is questionable due to the anchoring line's elasticity. Ignoring this limitation, the mean

maximum recorded surplus torque after deducting theoretical trees' masses would suffice for trees in the 20 cm and 35 cm classes with leans of 6° and 0°, respectively.

Capacity is an important factor in evaluations of tools for practical forest work, which, however, also need to consider ergonomic aspects. For instance can the inappropriate use of felling levers cause back strains (Härkönen 1978) and a strive to minimize equipment weight might talk against the powerful but 14.5 kg heavy forestry jack.

#### Further research

This article provides evidence that the proposed method can be used in evaluations of the torque generated by felling tools and should be seen as a first attempt to develop a standardized procedure. Due to its pioneering character, the article had to be based on simplifying assumptions. Our hope is that this first step towards a working methodology opens the field for further research and on a greater detailed level. To further develop and evaluate the method, a crucial variable to address is the anchor line's flexibility and its initial tension, since it seems to influence the method's suitability for repeated testing. However, systematic variation of the anchoring line tension would provide opportunities to simulate the effects of different tree loads, due to variations in variables such as biomass, wind, leaning and snow. The relationship between the hinge's bending resistance and leaning angle also warrants further examination. Furthermore, studying different categories of tools generating the same range of input torques would enable efficiency comparisons, which were not possible in this study. For the studied tools, the felling lever's force development needs further research and the forces applied to wedges and the resulting torques would benefit from further elaboration.

#### Conclusions and applications of the method

Theoretically, a tree tips over when a surplus torque is created, i.e. when the input torque exceeds the sum of the tree's mass torque and the hinge's bending resistance. When using felling tools, wood deformation between the tool and wood also needs to be accounted for. The present method included all factors except the tree's mass torque when recording surplus torque and proved to be suitable for testing felling tools' capacities. The method in its present form is, however, destructive and only allows a small number of tests to be performed per trial stem. The method has potential for practical use in repeated measurements in at least three different forms. The most laboratory-based form would be to vary initial tension to evaluate a tool's capacity to

generate surplus torque using vertically anchored stems simulating real trees. The stem could be attached to a known resistance (e.g. a hanging weight) and the stem's movement would indicate the surplus torque, i.e. successful tool work. A more field-adapted version could be developed if the hinge resistance could be compensated for in post-test calculations. The hinge resistance could then be minimized by cutting a thinner than normal hinge and stem leaning movements prior to trials and repeated measurements could be applied under similar conditions for different tools, especially if the weakest tools were tested first. A more elaborate version would be to use simulated tree trunks with hinges with torque wrench characteristics, to enable resistance to be adjusted and calibrated. Irrespective of the potential applications, a well developed and validated standardized testing method could provide reliable recommendations of felling tools' limits, as illustrated in Fig. 9, and thus help to reduce both human injuries and damage to property.

#### ACKNOWLEDGEMENTS

This study was conducted as part of the *FOR-programme*, which aims to improve private forest owners' working conditions, and was financed by the Faculty of Forest Sciences at the Swedish University of Agricultural Sciences. The Regional Forestry Board in Västerbotten, Bahco AB and Gränsfors Bruks AB kindly provided testing material. Francesco Petronzi, Marie Hansson and Marcus Åström are thanked for help with the field work. Thanks are also due to Annika Moström, Gun Lidestav and three anonymous reviewers for valuable comments on a previous manuscript, to Sören Holm for statistical advice and to Sees-Editing Ltd. for revising the English.

#### Literature cited

- Ager, B., Nilsson, N.-E. and von Segebaden, G. 1964. Description of some for logging operations important characteristics of forest stands, trees and terrain in Sweden. *Studia Forestalia Suecia* 20. Skogshögskolan. Stockholm. 159 pp. [In Swedish with English summary].
- Anon. 1947. *Forstgerechtes Baumfällen* [Correct Tree Felling in Forestry]. Hannover Gesellschaft für forstliche Arbeitswissenschaft e. V. 79 pp. [In German].
- Anon. 1999. *Wood handbook - Wood as an Engineering Material*. General Technical Report FPL-GTR-113. U.S. Department of Agriculture, Forest Service, Forest Products Laboratory, Madison, WI. 463 pp.
- Axelsson, S.-Å. 1998. The mechanization of logging operations in Sweden and its effects on occupational

- safety and health. *Journal of Forest Engineering* 9(2), pp. 25-31.
- Blom, J.-E., Johansson, B. and Öhlund, T. 1973. Arbetskydd vid avverkningsarbete bland självverksamma skogsägare. En undersökning i L, X och BD län [Worker safety in logging among self-employed forest owners. A survey in L, X and BD county]. Report No. 16. Statens Skogsmästarskola. Skinnskatteberg, Sweden. 22 pp. [In Swedish].
- Brunberg, B., Gårdh, R. and Lindgren, P. 1984. Felling Manual. The Forest Operations Institute of Sweden. Stockholm. 28 pp.
- Carlsson, S. 1997. Lifting levers. The design, use and performance of lifting levers for felling with special reference to experience and recent studies. *Small Scale Forestry* 2:1997, pp. 14-18. Infoskog-Inforest. Garpenberg, Sweden.
- Conway, S. 1978. *Timber Cutting Practices*. 3 revised edition. Miller Freeman Publications, Inc. San Francisco, USA. 192 pp.
- Dinwoodie, J. M. 2000. *Timber: Its nature and behaviour*. 2 ed. E & FN Spon. London. 257 pp.
- Engsås, J. 1993. Accidents in small-scale forestry - prerequisites for accident prevention among private wood-lot owners. Research Notes No. 251. Department of Operational Efficiency, Swedish University of Agricultural Sciences. Garpenberg. 121 pp.
- FAO 1980. *Chainsaws in Tropical Forests*. FAO Training Series. Vol. 2. Food and Agriculture Organization of the United Nations. Rome, Italy. 95 pp.
- Fredenberg, K. 1892. Om stämpling, huggning och utforsling och mätning af sågtimmer [About marking, cutting and extraction and measuring of saw timber]. Afhandlingar och prisskrifter, Andra häftet. Föreningen för skogsvård i Norrland. Stockholm. 44 pp. [In Swedish].
- Friberg, V., Delin, G. and Ottosson, S. 1974. Arbetskydd och arbetsteknik vid huggningsarbete bland självverksamma skogsägare [Work safety and work technique in logging among self-employed forest owners]. Report No. 12. Statens Skogsmästarskola. Skinnskatteberg. 24 pp. [In Swedish].
- Guimier, D. Y. 1980. *Tree-Falling Mechanics*. Technical Report TR-42. Forest Engineering Research Institute of Canada. 28 pp.
- Gustafsson, L., Lagerlöf, E. and Pettersson, B. 1970. Analys av olyckstillbud vid huggning [Analysis of near accidents in cutting]. Research Notes No. 37. Department of Operational Efficiency, Royal College of Forestry. Stockholm. 19 pp. [In Swedish].
- Gårdh, R. 1974. Arbetskydd och arbetsteknik vid huggning på Gotland [Worker safety and work technique in cutting on Gotland]. Report No. 18. Statens Skogsmästarskola. Skinnskatteberg. 31 pp. [In Swedish].
- Hache, F. E. 1954. *Die Motorkettensäge*. Handbuch für die forstliche Praxis [The Motor Chainsaw. Handbook for the Forest Praxis]. Deutscher Bauernverlag. Berlin. 148 pp. [In German].
- Husqvarna 2003. *Arbete med motorsåg*. Manual för säker och effektiv användning av motorsåg [Work with Chain Saw. Manual for Safe and Efficient Use of Chain Saw]. Huskvarna, Sweden. 82 pp. [In Swedish].
- Hägglund, B. and Lundmark, J.-E. 1987. *Handledning i bonitering med Skogshögskolans boniteringssystem* [Manual for Site Quality Assessment with the Skogshögskolan System]. 3 ed. National Board of Forestry. Jönköping, Sweden. 53 pp. [In Swedish].
- Härkönen, P. 1978. *The Chainsaw - Use and Maintenance*. The National Forestry Board of Sweden. Jönköping, Sweden. 65 pp.
- ILO 1998. *Safety and Health in Forestry Work: An ILO Code of Practice*. 1:st ed. International Labour Office. Geneva, Switzerland. 166 pp.
- Koroleff, A. 1947. Pulpwood cutting. Efficiency of technique. Woodland Section 630 (B-7-a). Canadian Pulp and Paper Association. Montreal. 130 pp.
- Lindroos, O. 2004. Sammanställning av småskalig skogsutrustning [Compilation of small scale forestry equipment]. Department of Silviculture, Swedish University of Agricultural Sciences. Umeå. 197 pp. [In Swedish]. Also available at <http://www.ssko.slu.se/~diwa/FOR.htm>, 2007-05-09.
- Lindroos, O., Lidestav, G. and Nordfjell, T. 2005. Swedish non-industrial private forest owners - self-employment and equipment investments. *Small-Scale Forest Economics, Management and Policy* 4(4), pp. 409-426.
- Mikleš, M. and Záchenský, O. 1995. Simulation of tree fall in the process of logging. *Lesnictvi - Forestry*, 41(9), pp. 408-414. [In Slovak with English summary].
- National Board of Forestry 1994. *Statistical Yearbook of Forestry 1994*. Jönköping, Sweden. 349 pp. [In Swedish].
- National Board of Forestry 2000. *Statistical Yearbook of Forestry 2000*. Jönköping, Sweden. 345 pp. [In Swedish].
- National Board of Forestry 2006. *Swedish Statistical Yearbook of Forestry 2006*. Jönköping, Sweden. 337 pp. [In Swedish].
- Nordfjell, T., Bacher, M., Eriksson, L., Kadlec, J., Stampfer, K., Suadicani, K., Suwala, M. and Talbot, B. 2004. Operational Factors Influencing the Efficiency in Conversion. In Spiecker, H. et al (eds), *Norway Spruce Conversion - Options and Consequences*. European Forest Institute Research Report 18: Koninklijke Brill NV. Leiden, The Netherlands. 269 pp.
- Silversides, C. R. and Sundberg, U. 1989. *Operational Efficiency in Forestry*. Volume 2: Practice. Kluwer Academic Publishers. Dordrecht, The Netherlands. 169 pp.
- Staaf, K. A. G. and Wiksten, N. A. 1984. *Tree Harvesting Techniques*. Martinus Nijhoff Publishers. Dordrecht, The Netherlands. 371 pp.
- Takalo, S. 1982. Kaadon apuvälinet [Felling aids]. *Koneviesti* 9(1982), pp. 26-27. [In Finnish].
- Thelin, A. 2002. Fatal accidents in Swedish farming and forestry, 1988-1997. *Safety Science* 40(6), pp. 501-517.
- Timoshenko, S. P. and Goodier, J. N. 1970. *Theory of Elasticity*. 3 ed. McGraw-Hill Inc. Tokyo. 567 pp.

Van Kott, H. P. and Kinkade, R. G., eds. 1972. Human Engineering Guide to Equipment Design. 2 ed. U.S. Government Printing Office: Whashington, D.C. 752 pp.

Widule, C. J., Vernard, F. and Demo, G. 1978. Dynamics of the Axe Swing. *Ergonomics*, 21(11) pp. 925-930.

Wikberg, G. 1992. Brytjärn för säkrare fällning - ergonomisk granskning [Felling levers for safer felling - ergonomical examination]. Arbetsdokument/Intern stencil No. 4 1992. Department of Operational

Efficiency, Swedish University of Agricultural Sciences. Garpenberg. 28 pp. [In Swedish].

Wilhelmson, E., Staal Wästerlund, D., Burström, L. and Bylund, P.-O. 2005. Public health effects of accidents in self-employed forestry work. *Small-scale Forest Economics, Management and Policy* 4(4), pp. 427-436.

## Tables and Figures

Table 1. Trial stem and hinge features

Feature	Diameter class			
	20 cm (n=21)		35 cm (n=21)	
	Mean	SD	Mean	SD
Trial stem				
Height (m)	1.67	0.02	1.69	0.26
Diameter at stump <sup>1)</sup> ub (mm)	170	8	312	15
Diameter at top ub (mm)	147	8	249	27
Bark thickness at stump (mm)	14	3	17	4
Notch height <sup>2)</sup> (mm)	59	7	106	9
Notch depth <sup>3)</sup> ub (mm)	29	6	58	10
Felling cut depth <sup>4)</sup> ub (mm)	115	7	212	30
Mass (kg)	32.3	3.2	94.9	10.3
Vertical distance from center of gravity to felling cut <sup>5)</sup> (mm)	803	17	800	19
Hinge				
Inner length of hinge <sup>6)</sup> ub (mm)	160	10	301	18
Outer length of hinge <sup>7)</sup> ub (mm)	127	15	246	35
Thickness of hinge <sup>8)</sup> (mm)	25	2	42	3
Dry density (kg m <sup>-3</sup> )	523.9	36.5	508.0	27.6
Moisture content (% of raw mass)	52.1	3.4	50.5	4.4

ub = under bark, <sup>1)</sup> dsh in Fig. 1, <sup>2)</sup> H<sub>N</sub> in Fig. 1, <sup>3)</sup> L<sub>N</sub> in Fig. 1, <sup>4)</sup> L<sub>F</sub> in Fig.1, <sup>5)</sup> h<sub>AM</sub> in Fig. 6, <sup>6)</sup> L<sub>HI</sub> in Fig. 1, <sup>7)</sup> L<sub>HO</sub> in Fig. 1, <sup>8)</sup> L<sub>HT</sub> in Fig. 1.

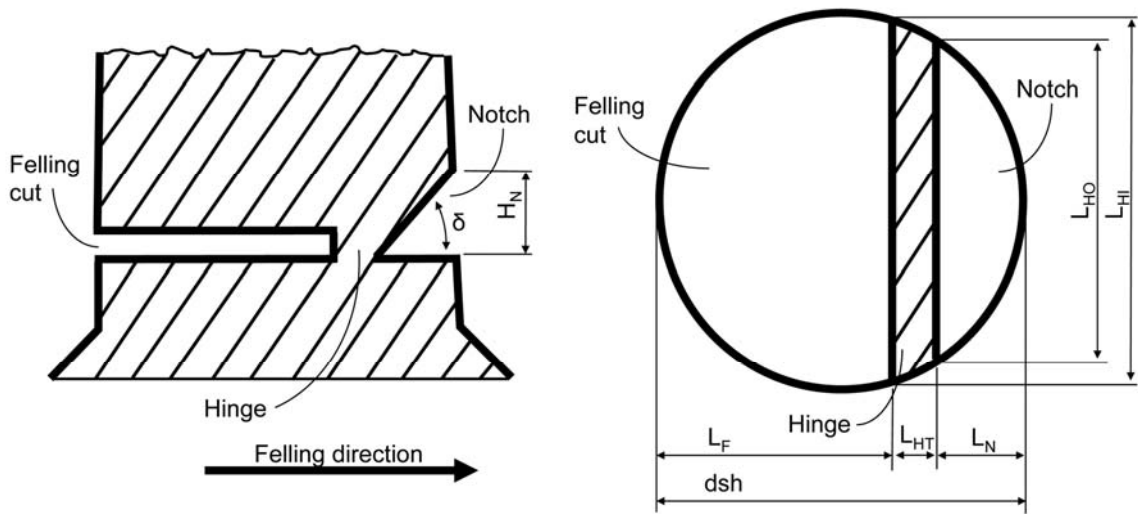

Figure 1. Schematic diagram of a tree stump and typical felling cut features; (left panel) side view:  $H_N$  = notch height,  $\delta$  = notch angle; (right panel) top view:  $L_F$  = felling cut depth,  $dsh$  = diameter at stump height,  $L_N$  = notch depth,  $L_{HT}$  = hinge thickness,  $L_{HI}$  = inner length of hinge,  $L_{HO}$  = outer length of hinge.

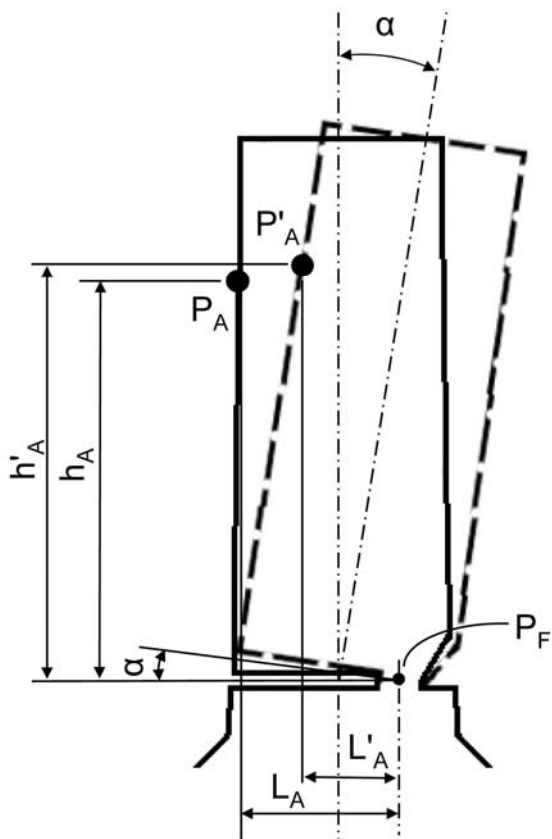

Figure 2. The effect on levers between a point  $P_A$  on the tree (here represented only in section) and the fulcrum ( $P_F$ ) as the stem leans. At a given leaning angle  $\alpha$ ,  $P_A$  is moved to  $P'_A$  and the initial levers  $h_A$  and  $L_A$  are transformed to  $h'_A$  and  $L'_A$ , respectively.

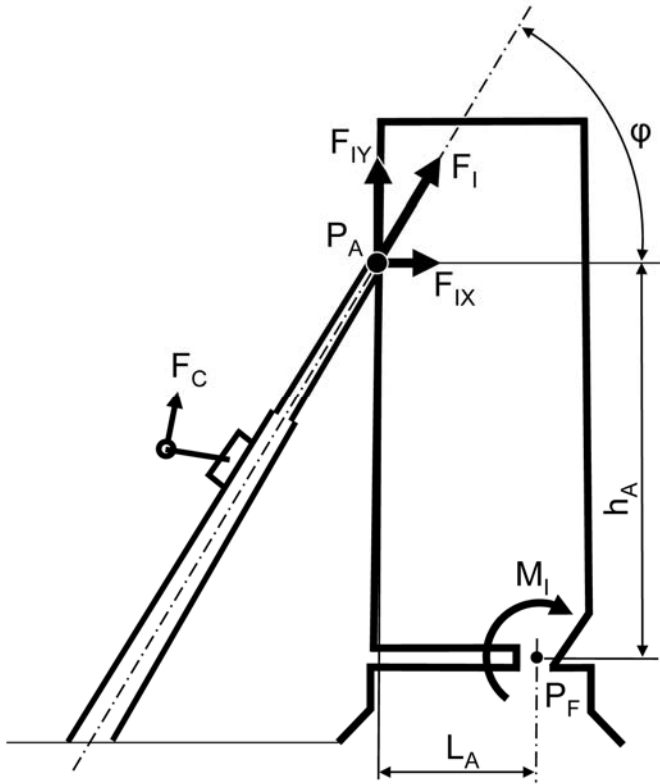

Figure 3. Forces, lever and angles involved in the use of a forestry jack.  $F_C$  = cranking force;  $F_I$  = input force that affects the stem;  $F_{IY}$  and  $F_{IX}$  =  $F_I$ 's vertical and horizontal components, respectively;  $M_I$  = input torque that affects the stem;  $P_F$  = stem's fulcrum;  $P_A$  = application point of  $F_I$ ;  $\phi$  = angle of application;  $L_A$  and  $h_A$  =  $P_F$  levers to  $P_A$ .

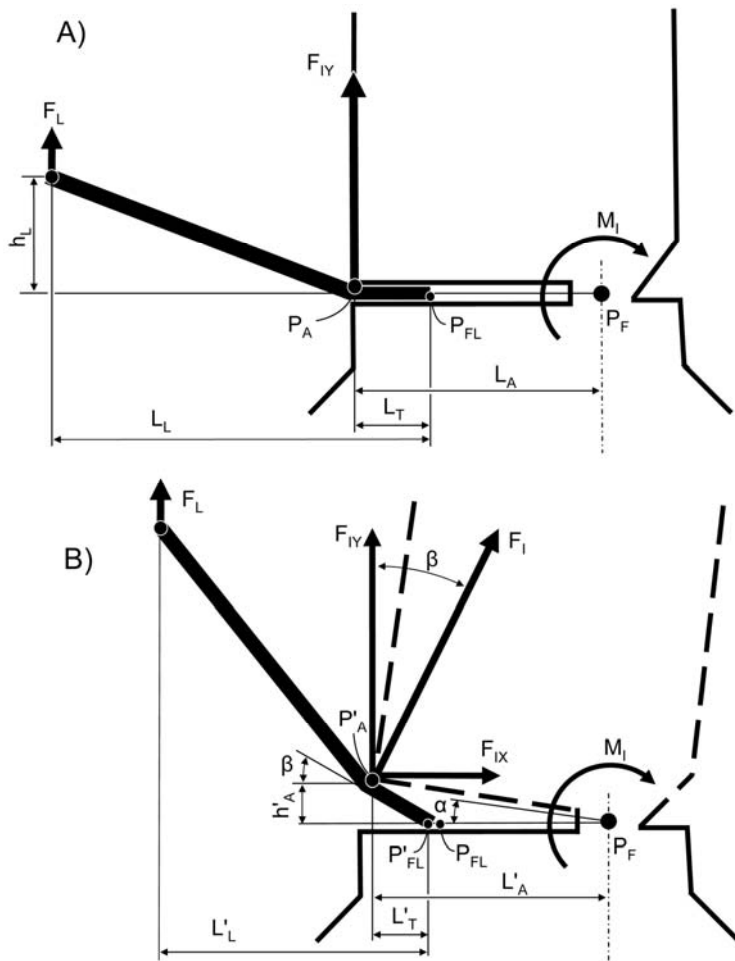

Figure 4. Effects on felling lever mechanics as the stem leans. The upper (A) and lower (B) figures illustrate the situations before and after stem movement, respectively. Symbols with a prime (') signify positions after movement.  $F_L$  = force applied to the felling lever;  $F_I$  = input force that affects the stem;  $F_{IY}$  and  $F_{IX}$  =  $F_I$ 's components;  $M_I$  = input torque that affects the stem;  $P_F$  = stem's fulcrum;  $P_A$  = application point of  $F_I$ ;  $P_{FL}$  = felling lever's fulcrum;  $\alpha$  = stem's leaning angle;  $\beta$  = felling lever's rotation angle around  $P_{FL}$ ;  $L_T$  and  $L_L$  = felling lever's lever components;  $L_A$  and  $h_A = P_F$  levers to  $P_A$ ;  $h_L$  = vertical distance between  $P_A$  and  $F_L$ .

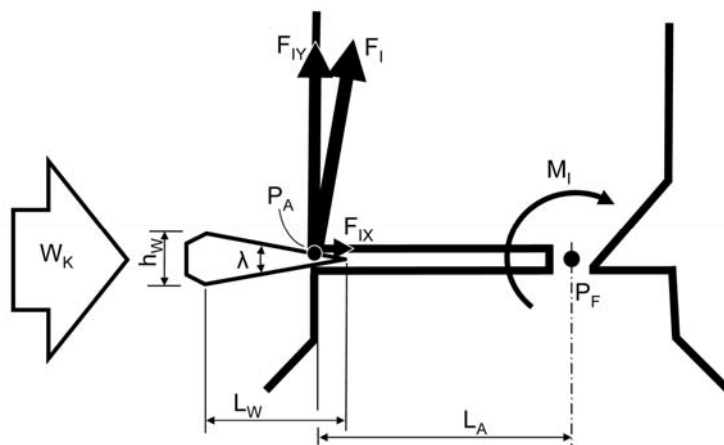

Figure 5. Forces, levers and angles involved in the use of a wedge.  $W_K$  = Kinetic energy;  $F_I$  = input force that affects the stem;  $F_{IY}$  and  $F_{IX}$  =  $F_I$ 's components;  $M_I$  = input torque that affects the stem;  $P_F$  = stem's fulcrum;  $P_A$  = application point of  $F_I$ ;  $\lambda$  = wedge angle;  $L_A$  = stem's lever;  $L_w$  = wedge's length;  $h_w$  = wedge's height.

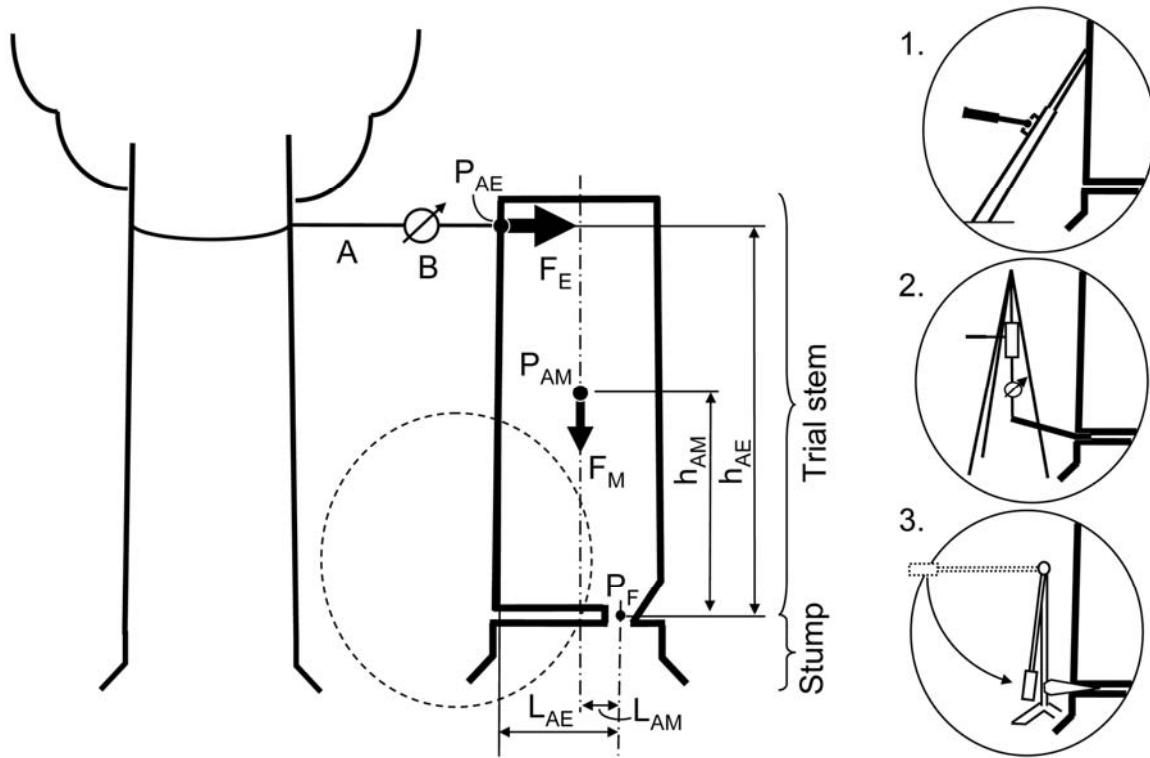

Figure 6. Experimental design. A = anchoring line, B = load cell;  $F_E$  = recorded force;  $F_M$  = gravitational force of the trial stem;  $P_F$  = stem's fulcrum;  $P_{AE}$  = application point of  $F_E$ ;  $P_{AM}$  = application point of  $F_M$ ;  $L_{AE}$  and  $h_{AE}$  = levers of  $F_E$ ;  $L_{AM}$  and  $h_{AM}$  = levers of  $F_M$ . Side figures: 1, forestry jack with torque wrench; 2, felling lever with tripod, hand winch and load cell; 3, wedge with pendulum.

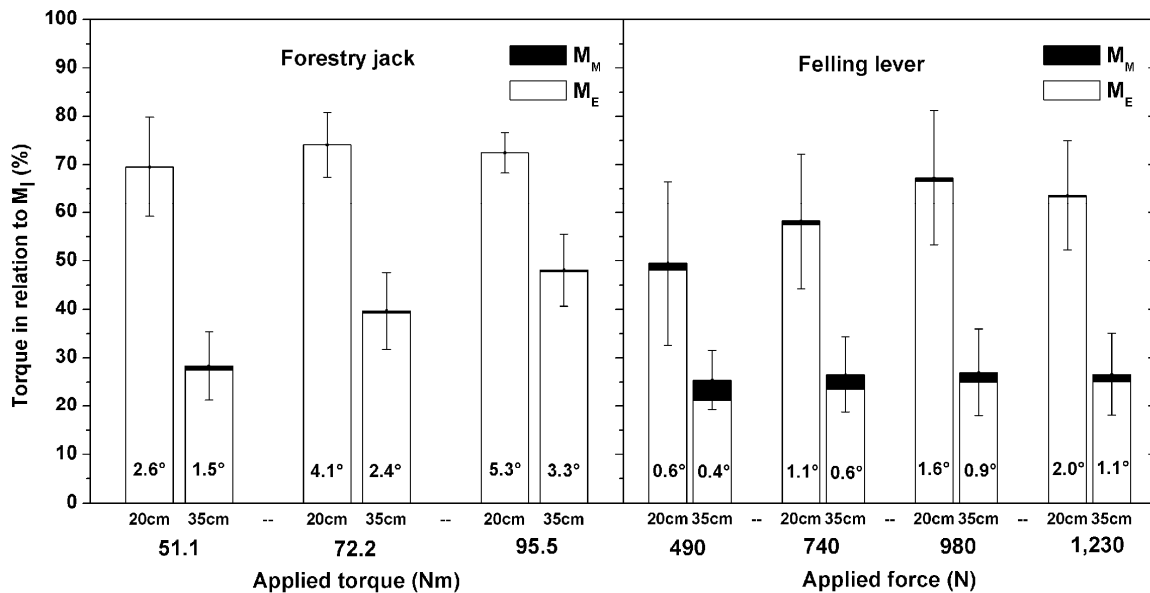

Figure 7. Surplus torque ( $M_E$ , Eq. 13) and tree weight torque ( $M_M$ ) as ratios of input torque ( $M_I$ ), by diameter class and torque applied to the forestry jack's crank handle axis or lifting force applied to the felling lever ( $F_L$  in Fig. 4).  $M_I = 100\%$  on the y-axis. Standard deviations are presented for the sums of  $M_E$  and  $M_M$ . The trial stems' mean leaning angle ( $\alpha$ ) is presented for each column.



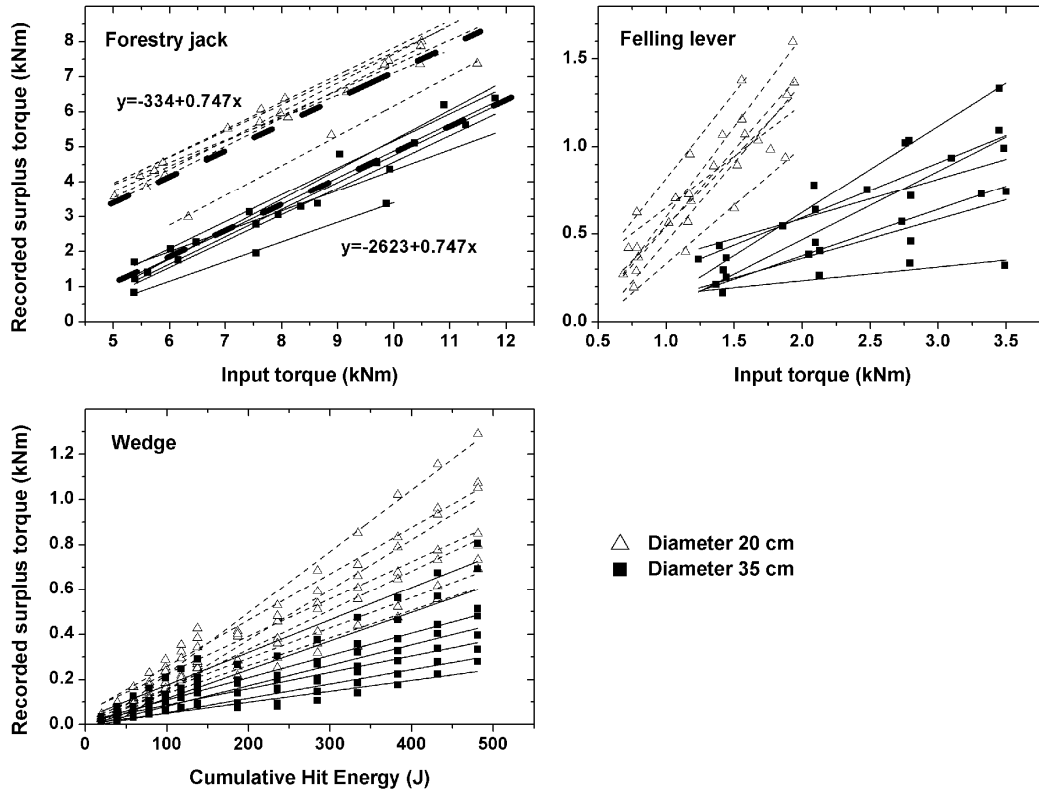

Figure 8. Recorded surplus torque ( $M_E$ , Eq. 13) for each of the felling tools as a function of input torque and cumulative hit energy (cf. Eqs. 1-10). The regressions originate from three observations per tree for the forestry jack, four for the felling lever and 14 for the wedge. For the forestry jack, the common regression line within diameter class is plotted in bold. For other tools, no common significant regression was found. Note the differences in the scales of the x- and y-axes.

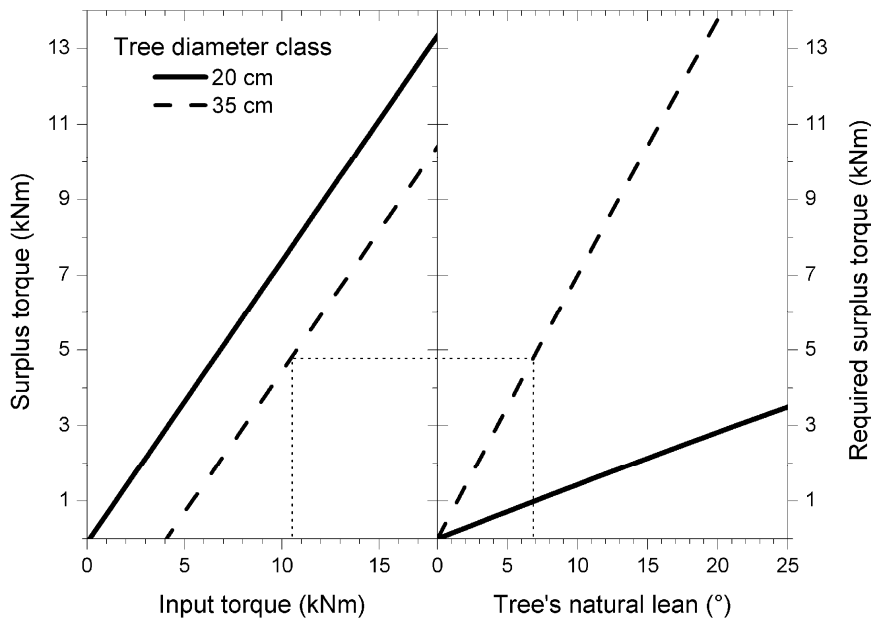

Figure 9. The forestry jack's capacity for the initial part of the felling process ( $\alpha=0$ ). The input torque required to fell a tree with a specific leaning angle can be estimated by transposing x-axes values with equivalent y-values between the two figures. For the 35 cm diameter class, for example, an input torque of 10.5 kNm generates a surplus torque of almost 5 kNm (thin dotted line), which is sufficient for trees leaning by almost 7 degrees.