



UNIVERSITÀ DEGLI STUDI DI SASSARI

SCUOLA DI DOTTORATO IN

**RIPRODUZIONE, PRODUZIONE, BENESSERE ANIMALE E
SICUREZZA DEGLI ALIMENTI DI ORIGINE ANIMALE**

Direttore Prof. Giovanni Garippa

**INDIRIZZO IN: RIPRODUZIONE, PRODUZIONE, BENESSERE ANIMALE
XXII CICLO**

(coordinatore: prof. Sergio Ledda)

**INVESTIGATION ON THE *BMP1B*, *BMP15* AND *GDF9* GENES
POLYMORPHISM AND ITS ASSOCIATION WITH
PROLIFICACY IN FIVE SHEEP BREEDS
REARED IN TUNISIA**

Docente Guida

Chiar.mo Prof. Giuseppe Massimo Vacca

Direttore

Prof. Giovanni Garippa

Tesi di dottorato della

Dott.ssa Anissa Dhaouadi

ANNO ACCADEMICO 2008 - 2009

Index

1	Introduction	”	3
2	Aim of the research	”	52
3	Materials and methods	”	55
4	Results and discussion	”	65
5	Conclusions	”	87
6	References	”	90

1. Introduzione

1. Introduction

1.1 Sheep as a genetic resource and its evolution

Sheep were probably first domesticated in the Fertile Crescent, approximately 8000 to 9000 years ago. Archaeological information suggests two independent areas of sheep domestication in Turkey (the upper Euphrates valley in eastern Turkey), and central Anatolia (Peters et al., 1999). The origin of the modern domestic sheep (*Ovis aries*) is still uncertain. Several wild sheep species or subspecies have been proposed as the ancestors of domestic sheep (Ryder, 1984) or are believed to have contributed to specific breeds. Most notably Urial (*O. vignei*) and Mouflon (*O. musimon* or *O. orientalis*) sheep have been suggested as the ancestor of modern breeds, but Argali (*O. ammon*) contributions have also been discussed (Zeuner, 1963).

Extensive cytogenetic studies conducted by Nadler et al. (1971) and Woronzow et al. (1972) of the wild sheep populations of Iran, Turkmenia, Tadschikistan, and Kazakhstan established the chromosome number of several mouflon ($2n = 54$), urial ($2n = 58$), and argali ($2n = 56$) populations. The authors concluded that their

chromosome data did not agree with ideas regarding the mouflon as the source of most domestic breeds, because European and Central Asian breeds of domestic sheep have $2n = 54$. This suggests the mouflon group as the ancestral stock from which domestic strains were derived. However, wild sheep populations with different chromosome number ($2n = 54$ and $2n = 58$) hybridize and give rise to animals with $2n = 55, 56,$ or 57 , which may have normal fertility (Nadler et al. 1971). Argali mouflon hybrid ewes with $2n = 55$ produce ova with 27 chromosomes. This suggests prezygotic selection toward a lower chromosome number and shows that the 54 chromosomes of modern domestic sheep need not have come solely from the mouflon (Hiendleder et al., 1998).

Sheep and goats lineages, diverged approximately 5-7 million years ago (MYA) (Maddox and Cockett., 2007). The origin of the *Ovis* genus is estimated to have occurred approximately 3 MYA, with the early *Ovis* prototypes giving origin to the North American bighorn sheep and Dall sheep. Bunch et al. (2006) reported that *Ovis aries* sheep lineage diverged from other sheep lineage such as *Ovis canadensis* and *Ovis dalli* about 1.4 million years ago. The argali diverged from the domestic sheep between 0.4 and 1.3 MYA.

Recently, Arnaud et al. (2007) and Chessa et al., (2009) brought new knowledge about the evolution of domestic sheep by studying

vertical transmission of endogenous retroviruses (ERVs) from generation to generation; these retroviruses are related to the exogenous and pathogenic Jaagsiekte sheep retrovirus (enJSRV). It has been established that the sheep genome contains at least 27 copies of ERVs (Arnaud et al., 2007). Analysis of distribution of each enJSRV provirus in domestic sheep and in other species within the subfamily Caprinae produced important data on virus-host coevolution and into the history of sheep domestication. Based on the combination of insertionally polymorphic enJSRV (retrotype), Chessa et al., have shown that during evolution of the genus *Ovis*, two distinct migration events occurred, directed from Southwest Asia towards Europe and Africa, and the rest of Asia, which lead to the presence of primitive sheep carrying a characteristic retrotype such as the Mediterranean Mouflon and the Soay sheep, considered as relicts of the first migration, and modern sheep breeds, with improved production traits, with a more recent retrotype.

1.2 Sheep breeds diffusion and production

The first agricultural systems, based on the cultivation of cereals, legumes, and the rearing of domesticated livestock, developed within

Southwest Asia ~11,000 years before present (yr B.P.) (Zeder et al., 2008; Colledge et al., 2005). By 6000 yr B.P., agro-pastoralism introduced by the Neolithic agricultural revolution became the main system of food production throughout prehistoric Europe, from the Mediterranean north to Britain, Ireland, and Scandinavia (Price, 2000); south into North Africa (Barker, 2002); and east into West and Central Asia (Harris et al., 1996).

Sheep and goats are reported to be the first domestic animals that were used for food production (Gentry et al., 2004) and they are also widely used for other products such as wool, hair and skin. They are both domesticated approximately 8000-11,000 years ago, and both were domesticated in at least two or three different geographical regions (Luikart et al., 2006; Topio et al., 2006).

There are currently more than 1300 breeds of sheep and more than 500 breeds of goats (Scherf, 2000).

Taking into account the distribution of the world's mammalian breeds by species, we can assert that sheep breeds contribute 25% to the total number of recorded mammalian breeds in the world, while goat contribute 12% and cattle 22% (FAO, 2007).

According to 2007 Food Agricultural Organisation (FAO) data, the total number of sheep reared in the world is estimated to be more than 1,112 billion, with 266 million being reared in Africa (23.9%), of

which 103 million in North Africa. In the last 10 years, the total number of sheep heads reared in Tunisia has increased by 17.40%, reaching 7,6 million heads in 2007 (FAOSTAT, 2009).

Table 1. Number of sheep reared in Tunisia

Year	1997	1998	1999	2000	2001	2002	2003	2004	2005	2006	2007
Total sheep	6239	6544	6576	6926	6860	6833	6613	6949	7213	7848	7618
Total female	3972	3943	3962	4053	4110	3990	3924	3963	4044	4095	4181

Source: Ministre de l'Agriculture et des Ressources Hydrauliques. Direction Générale de la Planification, du Développement et des Investissements agricoles, 2007

Figure 1. Evolution of sheep breeds in Tunisia (1997-2007)

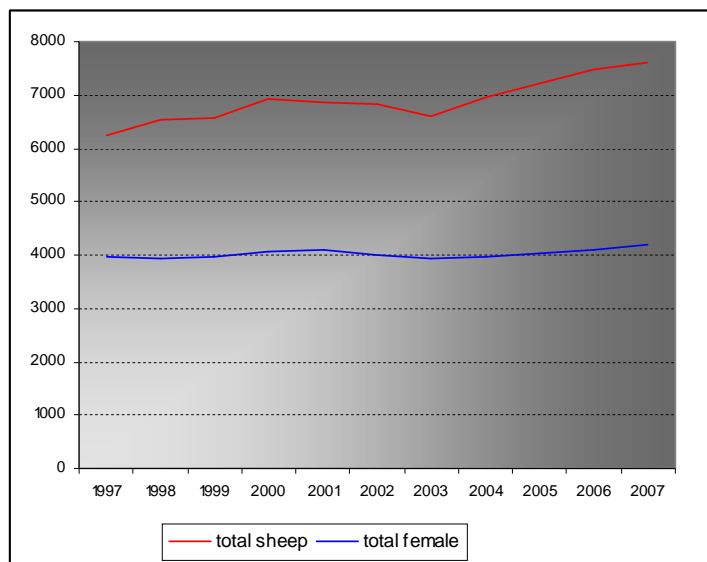

Sheep meat production has correspondingly increased by 17,50% accounting for 22.35% of red meat consumed (FAOSTAT, 2009). The

contribution of sheep to red meat production in Tunisia is remarkable, mainly in the regions of the Centre and South, where it reaches 65% (FAO, 2007).

2. Tunisian sheep breeds

As with most Mediterranean countries, particularly those on the southern shore, in Tunisia sheep production holds an important place in the economy.

Small ruminant production in Tunisia represents an important activity in the agricultural environment, particularly through its contribution to national meat production and its repercussion on the rural physical and social backgrounds (Bedhiaf-Romdhani et al., 2008).

The diversity of the breeds, their wide geographical distribution and their integration into agricultural production systems whether extensive or intensive, are the main attributes of the sector's potential in the country. The sector is largely dominated by the indigenous Barbarine and Queue Fine de l'Ouest meat breeds. These two breeds assume a national importance as they will continue to be the main meat providers to Tunisian commercial channels, and will

significantly contribute to meeting the objectives of the national strategy aimed at red meat self-sufficiency. Nevertheless, other indigenous breeds, the Noire de Thibar sheep and the Sicilo-sarde sheep ensure a regional importance that needs to be preserved for milk and meat production (Rekik et al., 2002).

Other than the indigenous breeds of sheep, small nuclei of introduced breeds are the Comisana, Moroccan Sardi and Lacaune, which exist mainly in numbers of one or two flocks of about 200 breeding ewes each. These flocks exist on state or cooperative farms. The most significant introduction of an exogenous sheep breed in Tunisia is that of the D'man. This breed was introduced in Tunisia for the first time in 1994 as a flock of two hundred breeding ewes and rams.

2.1. Geographic Breed Distribution and Associated Ecosystems

Sheep breeding is spread throughout the country, with mixed farms rearing cattle, sheep and goats in the North, and sheep and goats in the South, corresponding to the semi-arid and arid bioclimatic zones (FAO, 2007).

Indigenous sheep breeds in Tunisia are widely distributed. The Barbarine and the Queue Fine de l'Ouest are more heavily concentrated in the country's center while the Noir de Thibar and the Sicilo-Sarde are northern breeds because of their higher nutritional requirements and their no tolerance of the prevailing harsher conditions in the central and southern areas of the country (figure 3).

Figure 2. Geographic distribution of sheep breeds in Tunisia

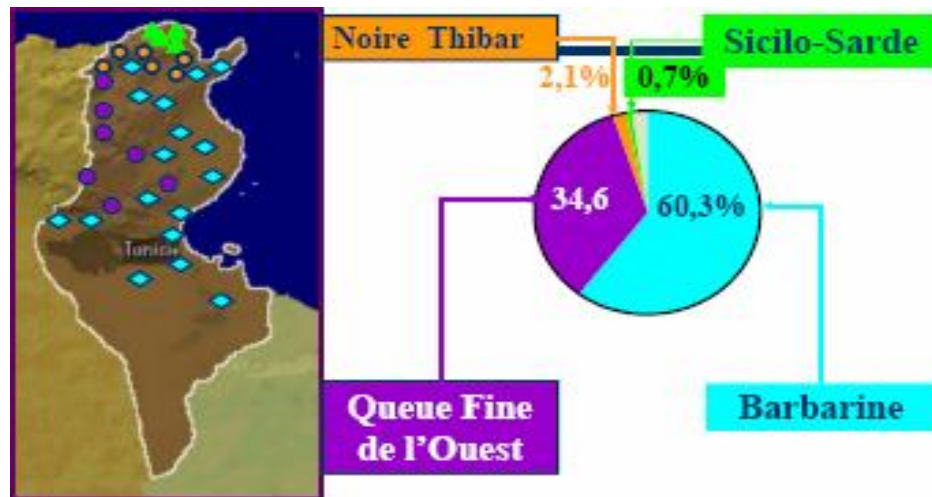

Source: Tunisie: Rapport National sur les Ressources Génétiques Animales

Furthermore, the D'man breed, a highly prolific sheep originating from Morocco, is now reared in Tunisia, being disseminated in the oasis of the south, and in 2000 its population was estimated to be around 3.500 breeding ewes (The Bureau of Livestock and Pastures: Office de l'Elevage et des Pâturages, 2001, Personal communication).

Figure 3. Number of sheep in the different Tunisian region

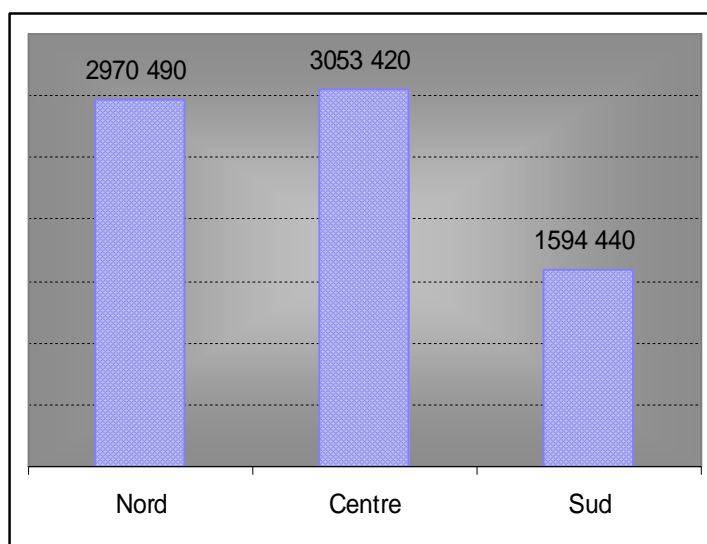

Source: Ministre de l'Agriculture et des Ressources Hydrauliques. Direction Générale de la Planification, du Développement et des Investissements agricoles, 2007

The ecosystem, where different breeds of small ruminants are distributed according to the diversity of the prevalent climate types, are defined through the central part of the country in the Mediterranean region for ever 7° latitude, linking the temperate regions in the north to the Sahara in the south. A large number of ecosystems used by sheep correspond to these different types of climate, making Tunisia a vast sheep producing area in the North Africa.

Three main distinct natural regions exist:

- a) Northern area; corresponds to the tell region. It is the most favourable part with a total area of 26,400 km². This part of the country includes the Dorsal Mountain Chain that gradually slopes downward to the east, the mountain Kroumirie and Mogds in the northwest and the fertile plains in the north. The climate is typically Mediterranean. Average annual rainfall varies between 500 and 1000 mm with a dry during the summer. Temperatures vary between 0 and 40° C. From west to east, the natural vegetation cover gradually passes from dense forests of *Quercus coccifera* (Cork-oak) to clear forests of *Pinus halepensis* (Aleppo pine), *Thuja oxycedru* (Thuja timbering), and bushes of *Ziziphus jujube*.
- b) Central region: corresponds to the steppe. This region covers an area of 41,100 km² and is limited in the north by the southern edge of the Dorsale Mountains that descend sharply by a series of plateau, and in the south by the Schott of Djerid and the Schott of Fedjedj. Average annual rainfall ranges between 400 and 500 mm from north to south and is dispersed sporadically throughout the year. The natural vegetation from north to south is typical of an arid climate: relics of *Pinus halepensis* (pine) and *Juniperus phoeniceaa* (common juniper) forests that are extended by bushy vegetation of *Stipa*

tenecissima (needlegrass), *Spartina spp* (cordgrass) and *Artemisia campestris* (sagebrush).

- c) Southern region: corresponds to Sahara. This region extends over 65,500 km² with a very dry and hot climate. Average annual rainfall varies between 50 and 200 mm and thermal range is large with temperatures varying between -7° C to 55° C in some areas. The frequent and continuous drought allows only a scarce and poor natural steppe vegetation to grow.

2.2. Sheep Breed Characterization

2.2.1 Barbarine Sheep

The Barbarine is the most characteristic type of sheep in Tunisia. It is now certain that the breed originates from the Asiatic steppes and it has been documented that its history in Tunisia was marked by two major waves of introduction. The first is associated to the Phoenicians about 400 B.C., and the second took place at the time of the Arab invasion around 900 A.D. (Khaldi, 1989). The breed is also called Najdi or Arbi.

- a) Breed appearance

It is a medium sized meat-type sheep characterised by creamy wool, cooper-red or black faces and legs, wide and pendulous ears, a flat and slightly concave forehead and usually the absence of horns. The head and legs are bare and the wool varies from coarse and kempy to medium-fine and wavy. The Barbarine sheep are known for their hardiness and their ability to adapt to either warm or cold climates. The height of adults animals ranges from 60 cm to 80 cm in males and from 55 cm to 70 cm in females.

The main physical feature of Barbarine animals is the presence of the fat tail, a bilobed sack of fat resulting from an accumulation of fat reserves on each side of the coccygeal vertebra. The fat tail presents large variations in shape and size due to genetic and other environmental factors (physiological stage, feeding level, etc.) and could reach up 15% of the total carcass weight in well-shaped adult animals. The fat tail represents a natural obstacle to free mating and shepherd assistance is required to lift it at copulation time.

b) Reproduction performance

The Barbarine is a seasonal breeder with a moderate depth anoestrus. This means that a variable proportion of ewes remain sexually active during anoestrus, with, however, dissociation between ovulation and oestrus. As a result, the mean duration of the breeding

season is longer than for temperate breeds, lasting 242 days and extending from mid-July to late February. Ovulation rate also shows seasonal variation, being highest during the natural breeding season (from June to January) at 1.60 and lowest during the anoestrus breeding season (from March to May) at 1.10, with an annual mean average of 1.32.

2.2.2 Queue Fine de l'Ouest Sheep

The Queue Fine de l'Ouest is derived from Ouled Djellal Sheep population in Algeria's eastern plateau and the breed is considered to be indigenous to western areas of Tunisia. The breed is also called Bergui.

a) Breed appearance

It is a medium-sized meat sheep characterized by uniformly white body, with sometimes a black or brown face. The animal has wide and pendulous ears, a flat forehead, and the head and legs are bare. The head has rectilinear profile. Females are polled, but males can be polled or horned. The wool is coarse to medium wool. Mature body weight varies between 65 and 80 kg for males and from 45 to 55 kg for females; size ranges from 60 to 75 cm. The Queue Fine de l'Ouest

is an alert and active, long-legged breed with a great ability to graze on uneven fields.

Figure 4. Queue Fine de l'Ouest Sheep



b) Reproduction performance

Seasonal Queue Fine de l'Ouest reproductive activity variations show patterns very similar to those reported for the Barbarine. The annual average ovulation of the breed stands at 1.16 ± 0.11 , reaching

a mean of 1.20 +/- 1.12 during the breeding season and dropping to 1.12 +/- 0.09 during the anoestrus season.

2.2.3 Noir de Thibar Sheep

Beginning in 1912, the breed was developed through a crossbreeding scheme involving the local Queue Fine de l'Ouest and the imported Merinos de la Crau breeds. This crossbreeding step was then followed by a series of highly inbred mating and strict selection to fix the black colour as the breed was developed in northern, sub-humid Tunisia. In this region photosensitization following consumption of *Hypericum perforatum* (hamra) by white animals, caused major economic losses to sheep farmers. The breed fixation was achieved by Catholic monks and was completed in 1945. The breed is all black with a white patch on the head appearing in 5% of the animals.

a) Breed appearance

The breed has an elongated, expressive head particularly at the level of the forehead. The head is flat, presenting a tuft of hair and is hornless in both males and females. The nostrils are fairly large and open; the muzzle is black and slightly wrinkled. The animal has wide,

pendulous ears and a short neck. The profile is rectilinear and the body is plain with large chest and back. The legs are bare, moderately long and fine. The leg is round and well developed. Rams have an average size between 66 cm and 70 cm, a chest measurement between 98 cm and 112 cm and weight from 70 kg to 80 kg. The size of the ewe varies between 60 cm and 65 cm and its body weight ranges from 50 kg to 60 kg. The wool is uniformly black, homogenous, medium fine and is in high demand for traditional carpet and clothing manufacturing because of its colour. The fleece is relatively heavy, weighing 4 kg to 5 kg in males and 2 kg to 3 kg in females.

Figure 5. Noir de Thibar sheep



b) Reproduction performance

Studies on reproductive seasonality have demonstrated that like the other meat producing breeds, namely the Barbarine and the Queue Fine de l'Ouest, the Noir de Thibar is an intermediate seasonal breeder with a variable proportion of ewes continuing the cycle throughout the year. The studies also brought evidence that that the breed has a higher ovulation rate than the two other breeds. Ovulation rate averages an annual mean value of 1.39 ± 0.25 reaching a maximum

between August and February, with an average of 1.53 +/- 0.20 and a minimum between March and July with a mean value of 1.25 +/- 0.23.

2.2.4 Sicilo-Sarde sheep

The Sicilo-Sarde breed, also called Siciliene in reference to its Italian origins, is the only milk sheep in Tunisia. The breed results from a poorly documented crossbreeding scheme between the Sarda and the Comisana, two dairy breeds originating from Sardinia and Sicily (Italy), respectively. The breed was created in the early 20th century with the aim of producing sheep cheese for the Italian community. Further crossings with the black strain of the Sarda were later carried out as the breed was established in the north where white faced animals were struck by photosensitization following the consumption of *Hypericum perforatum* (hamra).

a) Breed appearance

As a result of the abovementioned crossings and others with Noir de Thibar (in order to improve lamb conformation and growth) the colour of the breed is very heterogeneous varying from all white to all black. Totally white animals represent 10.30%, while animals with

coloured muzzle and nostrils represent 33.4%, gray animals with coloured muzzle and nostrils represent 15.8% and black animals with coloured muzzle and nostrils represent 12.7%. Spots of different colours around the eyes, nose, belly and legs are quite common. The breed has a coarse, non homogeneous wool quality and, in general, an elongated and polled head. The size of the animals varies from 70 cm to 80 cm, adult males weighing 70 kg and adult females weighing 45 kg. The body is regular and long with a thin tail and long, fine members.

Figure 6. Sicilo-Sarde sheep



b) Reproduction performance

In comparison with the meat-producing breeds, far less information is available on the reproductive characteristics of the Sicilo-Sarde. The *Office de l'Élevage et des Paturages* (OEP) database related to flocks in the selection base give average figures of 81.3%, 1.29% and 6.2%, respectively, for fertility rate, litter size/ewe and lamb death rate, measured in 12 flocks between 1987 and 1990. We could, however, hypothesize that the breed has a shallow anoestrus like most other sheep breeds in the country, as farmers continue to mate their animals in spring.

2.2.5 D'man sheep

This breed was introduced in Tunisia for the first time in 1994 as a flock of two hundred breeding ewes and 12 rams. The breed has been reared in the oases of the south, and in 2000 its population was estimated to be around 3.500 breeding ewes (Bureau of Livestock and Pastures: Office de l'Élevage et des Paturages, 2001, Personal communication). The D'man is a very special breed confined to the sub-Saharan oases (palmeraies) in the southeast of Morocco between the high Atlas and the Sahara. Its origin was in the Tafilalet (in the Ziz valley) and it has spread to the Dades valley and the Dra valley, because of the traditional exchange of animals between the Draoui and the Filali tribes, in Morocco.

a) Breed appearance

The name D'man came from the general black colour of the breed. Although animals can be black, brown, white or variegated. Both male and female are polled, and the neck sometimes carries wattles. The fleece of variable quality is covering mainly the back, the face always being completely bare.

Figure 7. D'man sheep



b) Reproduction performance

The D'man has a precocious puberty (219-229 d), a short post partum anoestrus (34-64 d), non seasonality of breeding and high prolificacy (2.86), with an ovulation rate (OR) of 2.85. D'man ewes are considered among the most prolific breed as this OR approaches that of other prolific breeds (Romanov 2.86, Booroola 2.68) (Lahlou-Kassi et al., 1988)

3. Sheep reproductive anatomy and physiology

Sheep is a polyestral seasonal species, with periods of sexual activity varying in function of the environment, the breed and feeding. The photoperiod plays an important role in this context, as the variation of the day length affects the production of melatonin. The reasons for this physiological system are related to the need of the animals to give birth during periods favorable to the survival of offspring.

Indeed, in the northern regions of our hemisphere, where the climate is rather cold, spring is the only favourable season for lambing, therefore the duration of sexual activity is limited. In temperate areas, however, where the best time for the birth is more prolonged, the sexual cycle of animals occur in a wider time frame (Bittante et al., 2005). At the latitudes of the Mediterranean area, estrous cycles are concentrated in the autumn, while breeds raised in areas near the equator come into heat (estrus) throughout the year, on the other hand, some English breeds such as Suffolk, are sexually active for only 2-3 months.

Reproduction is a sequence of events beginning with the development of the animal's reproductive tract. After birth, the animal must reach puberty to be able to produce fertile gametes (De Rensis, 2001). Puberty denotes the phase of growth in which full reproductive function is reached, which in the female leads to

the production of fertile eggs. Ewe lambs reach sexual maturity at about 120-180 days: the first heat usually occurs between 4 and 7 months, depending on the breed, when the young female reaches a live weight of 40-60% its final weight. The first heat is usually silent, not associated to the classic sexual behavior. This is due to the fact that the ewe lamb requires a previous exposure to progesterone, which should sensitize the ovaries to stimulation by pituitary hormones.

Nutrition is one of the main factors influencing the age of the onset of sexual activity, because insufficient intakes of nutrients may delay the development of the reproductive tract and hence the appearance of the first heat. Another factor that influences the onset of puberty is the photoperiod, because the seasonality is not limited to sexually mature animals.

Figure 8. Organs of principal reproductive importance in the ewe

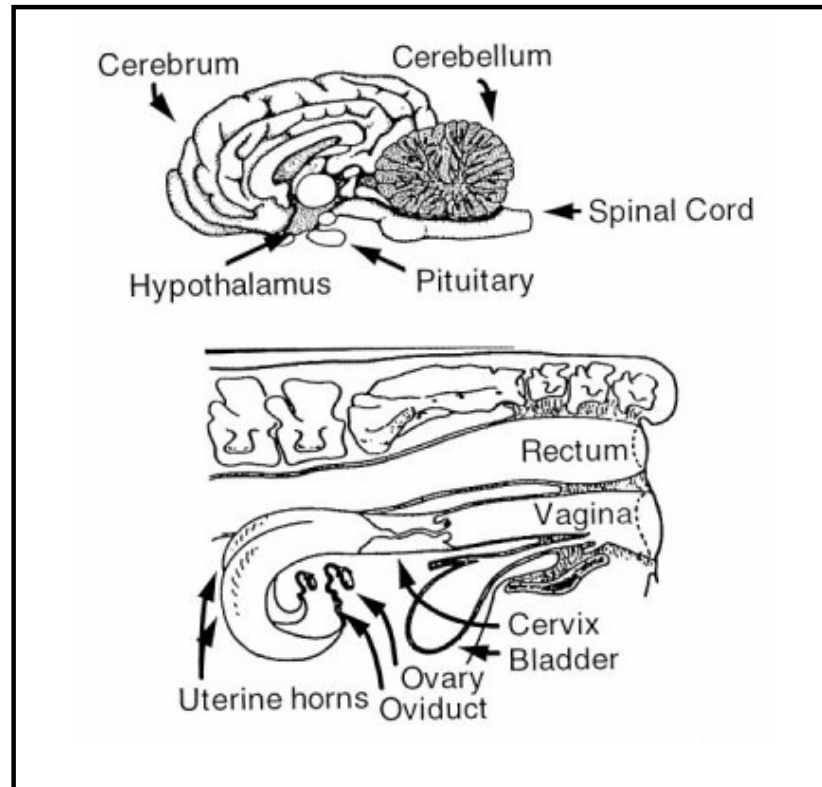

The estrous cycle. The sheep estrous cycle lasts an average of 17 days (ranging between 14-19), and the duration of oestrus is approximately 30-60 hours with variations from 24 to 48 hours. The estrous cycle is generally shorter in ewe lambs, at their first breeding season; it is also of shorter duration in the early and in the final stages of the sexual season. The estrous cycle seems to be shorter when rams constantly live in contact with ewes, rather than when the contact is discontinuous.

Ovulation usually occurs in the second half of the estrous cycle, with the rupture of 1-3 follicles, usually observed before the end of the oestrus cycle and it is more closely related to the end rather than the beginning of the heat. In sheep, the number of ovulations increases up to 4-5 years of age in relation to the earliness with which the breed reaches sexual maturity, then decreases. Ovulation shows, among the various sheep breeds, substantial variations due to genetic factors. For example, the Australian Merino breed give birth at an older age, predominantly a single lamb, while the Finnish-Landrace or the Finn breeds give birth on average three lambs, and litters of 4 to 5 lambs are likely to occur. Genetic factors influence both the number of ovulations and the number of births (Hafez, 1984).

Neuroendocrine control of reproduction. Reproductive activity is under hormonal and nervous control, it is a complex process that relies on many feedback mechanisms. All the mechanisms that govern follicular development are regulated mainly by endocrine factors. The activity of the gonads is controlled by the hypothalamus and the anterior pituitary gland. The hypothalamus is located at the base of the brain, it is composed of several symmetrical nuclei which are capable of secreting several peptide hormones for the control of the pituitary activity.

Through the hypothalamo-hypophyseal portal system and also directly through the axons of neurons, hypothalamic hormones are carried to the pituitary (Hafez, 1984; Cunningham, 2006). There is not only a blood flow from the hypothalamus to the pituitary gland, but part of the venous blood returns from the anterior pituitary to the hypothalamus, with retrograde flow. Consequently, the hypothalamus is exposed to high concentrations of pituitary hormones that pass in a retrograde direction.

The physiological importance of these mechanisms is remarkable, since they allow a negative feedback regulation of the hypothalamus, by the pituitary hormones (Hafez, 1984). The gonadotropin-releasing hormone (GnRH) is the most important product of the hypothalamus, it is a releasing factor that controls the release of pituitary gonadotropins: LH and FSH, which regulate the development of the follicle, ovulation and corpus luteum formation.

The pituitary gland is structurally and functionally divided into two portions: the adenohypophysis or anterior lobe, and the neurohypophysis or posterior lobe. The adenohypophysis is an endocrine gland, responsible for the synthesis and secretion of several protein hormones with various systemic functions.

Among these hormones, the most important for the control of reproduction, are two hormones called gonadotropins, FSH and LH. FSH or follicle stimulating hormone is the hormone that starts ovarian activity, as it determines the selection, initiation of growth and the maturation of ovarian follicles. LH or luteinizing hormone, presides in synergy with FSH, follicular development, furthermore it is responsible of ovulation and corpus luteum formation and maintenance. Gonadotropins then act at ovarian level (Aguggini et al., 1992).

Ovarian cycle. The sheep ovarian cycle can be divided in a luteal phase, characterized by the presence of a corpus luteum and high blood levels of progesterone, and a follicular phase, characterized by the final stages of maturation of follicles, ovulation, high levels of estrogens, absence of corpus luteum and low levels of progesterone.

The folliculogenesis concerns all the processes of growth and maturation of the ovarian follicles between the stage of primordial follicle and the ovulation. Its biological purpose is the production of ovocytes able to the fertilization and the development. It begins from the 70th day of gestation to the ovine foetus, that is as soon as the first primordial follicles are formed.

Lambs possess between 100 thousand and 200 thousand follicles at birth (Land, 1970).

Primary follicles become preovulatory Graafian follicles which, with their dehiscence, allow ovulation to occur. The Graafian follicles are formed by proliferation of follicular cells, which form the granulosa cells: the layer of these cells closely adherent to the oocyte is known as corona radiata.

The oocyte is surrounded by the corona radiata and by the follicular antrum, produced by the granulosa cells. The follicle is surrounded by the theca interna and theca externa (derived from ovarian stroma cells), which contribute to the formation of the corpus luteum after ovulation (Aguggini et al. 1992).

In order to continue the follicular development beyond the preantral stage, the granulosa and theca cells must develop receptors for gonadotropins. The receptors for FSH are developed on the theca cells, and those for LH on granulosa cells.

The preovulatory LH peak starts 24 hours before ovulation, and in the follicle determines the beginning of the critical changes that determine the release of the oocyte. The resumption of meiosis results in the first meiotic division (meiosis I), and the formation of the first polar body, which is completed before ovulation.

The oocyte, still surrounded by cumulus oophorus, is expelled along with follicular fluid and is collected from the oviduct (follicular dehiscence). Subsequently, the collapsed follicular cavity is filled by a tissue rich in blood vessels. Granulosa cells predominantly, but also those of the theca, proliferate and undergo hypertrophy and transformation: quickly a new endocrine organ is formed, the corpus luteum, which has the main function to secrete progesterone, a hormone which prepares uterus for the arrival of a developing embryo and the early stage and the maintenance of pregnancy (Aguggini et al, 1992; Cunningham, 2006).

Figure 9. Principal stage of ovarian development follicules

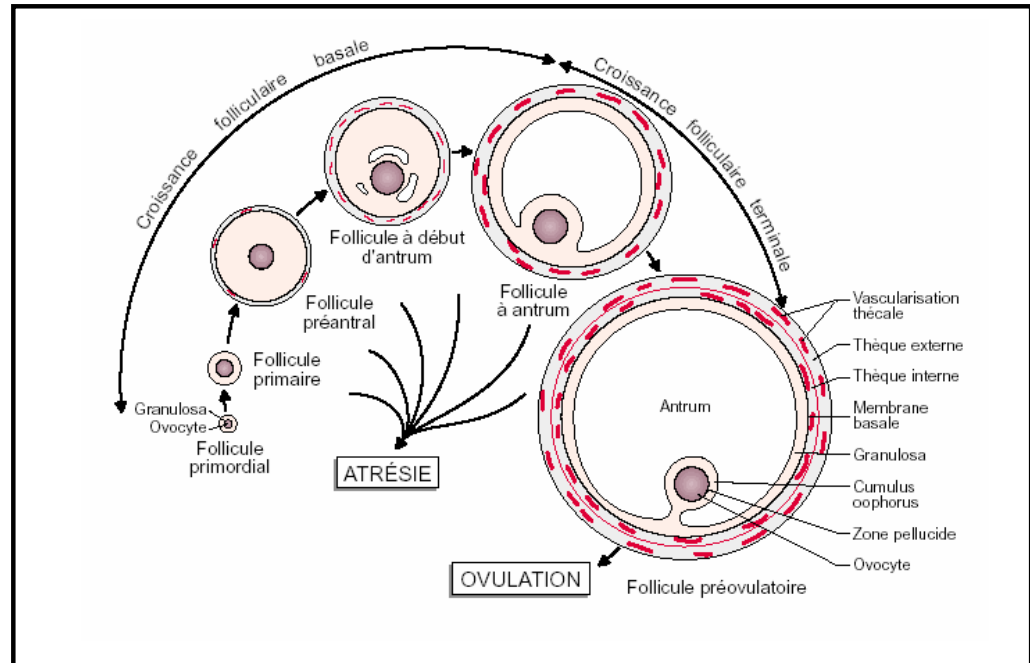

4. Prolificacy and genetic polymorphism affecting ovulation rate in sheep

Prolificacy is measured by the ewe's ability to produce multiple lambs e.g. twins and triplets, through high ovulation rate and high embryo survival. There are several factors affecting ovulation rate of ewes:

- genetics
- stress levels
- animal health
- pasture type and quality
- ewe weight
- ewe age, (Kareta et al., 2006)

Notter (2000) confirmed, also, in his study that prolificacy was affected by age of the ewe and was higher for ewes lambing between 4 and either 7 (Polypay) or 8 (Targhee and Suffolk) years of age.

Studies of the inheritance patterns of ovulation rate and litter size into programmes of genetic selection in sheep, whose main objective is to improve prolificacy, have indicated that litter size can be genetically regulated either by a set of different genes each having a small effect, as in the Romanov breeds (Ricoardeau et al., 1990), or alternatively by the action of single genes with major effect, named

fecundity (Fec) genes. In this respect, sheep has been considered as a model species to identify genes involved in mechanisms controlling ovulation rate. Thus, for the past two decades, geneticists have created informative families for segregation studies and fine mapping for some of the major genes affecting ovulation rate. Concomitantly, physiologists have largely investigated endocrine regulations of the reproductive axis (hypothalamus-pituitary-ovary) in low, compared to high ovulation rate breeds. The common goal was to identify key genes and physiological regulations that determine ovulation rate in ovine species (Fabre et al., 2006).

Recently, studies in mutant sheep have shown that members of the transforming growth factor β (TGF β) superfamily and their related cell-surface receptors are important intra-ovarian regulators of development and/or of ovulation rate (Galloway et al. 2000; Mulsant et al. 2001; Souza et al. 2001; Wilson et al. 2001). Some of the key growth factors and related receptors that have been identified thus far are inhibin, anti-Mullerian hormone, growth differentiation factor 9 (GDF9), bone morphogenetic protein 15 (BMP15; also known as GDF9B) and bone morphogenetic receptor type 1B (BMPR 1B; also known as ALK-6).

Figure 10. Relationship between BMP system and ovulation rate in sheep

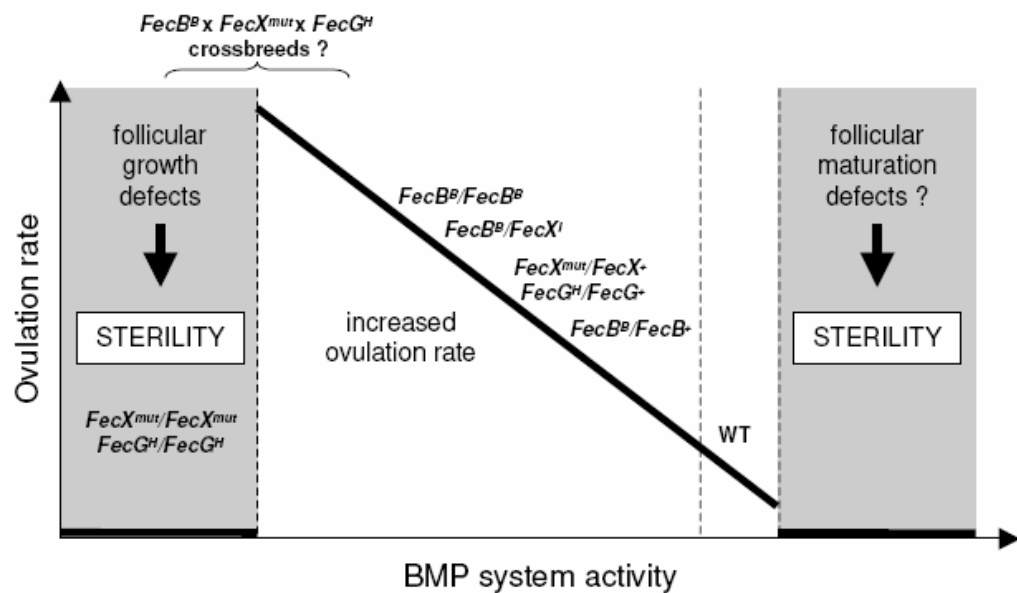

4.1 Bone Morphogenetic Proteins (BMP)

Bone morphogenetic proteins (BMPs) are multi-functional growth factors that belong to the transforming growth factor beta (TGF β) superfamily (Zhu et al., 2008). The roles of BMPs in embryonic development and cellular functions in postnatal and adult animals have been extensively studied in recent years. Signal transduction studies have revealed that Smad1, 5 and 8 are the immediate downstream molecules of BMP receptors and play a central role in

BMP signal transduction. Studies from transgenic and knockout mice and from animals and humans with naturally occurring mutations in BMPs and related genes have shown that BMP signaling plays critical roles in heart, neural and cartilage development. BMPs also play an important role in postnatal bone formation. BMP activities are regulated at different molecular levels. Preclinical and clinical studies have shown that BMP-2 can be utilized in various therapeutic interventions such as bone defects, non-union fractures, spinal fusion, osteoporosis and root canal surgery. To date, around 20 BMP family members have been identified and characterized (Chen et al., 2004).

4.2 Transforming Growth Factor- β (TGF β) superfamily

The transforming growth factor- β (TGF β) superfamily contains over 35 members, many of which have been shown to be important for regulating fertility (Knight and Glister, 2001; Chang et al., 2002; Lin et al., 2003; Juengel et al., 2004). The TGF β growth factors are multifunctional proteins that act through specific receptors to regulate growth and differentiation in many cell types, including those within the ovary (Elvin et al., 2000; Otsuka et al., 2001). Members of this family play essential roles during embryogenesis in mammals,

amphibians and insects as well as in bone development, wound healing, haematopoiesis, and immune and inflammatory responses.

They also play critical roles in the fertility of mammals with the growth factors, GDF9 and GDF9b, localized in the oocyte (Young et al., 2008), and BMP receptors expressed in the ovary (Wilson et al., 2001).

Some of them may activate signalling from the cell surface through binding to receptor complexes called type I and type II serine/threonine receptors (Gilboa et al., 2000; Gouedard et al., 2000). The activated receptor complexes then stimulate intracellular messenger, called Smad proteins, to propagate the cell-surface signal to downstream substrates. Signal specificity is determined by the specific ligand and cell surface receptor subtype (e.g. ALK-I to ALK-6) and by different Smad proteins (Wilson et al, 2001, Souza et al, 2001).

4.3 Mutations in the Bone Morphogenetic Protein Receptor 1B (BMPR 1B)

Litter size and lamb growth are important economic values in sheep breeding and reproduction.

Mulsant et al. (2001), Souza et al. (2001), Wilson et al. (2001) and Davis et al., (2006) reported that a specific mutation occurring at the *BMPR 1B* gene, also known as ALK-6 (Activin Receptor-Like Kinase-6) is responsible for the high prolificacy associated with the *FecB* genotype in Booroola Merino sheep.

a) History of the Booroola gene or Fec B

The term “Booroola” was taken from the name of the ranch in Australia where sheep carrying the single gene for prolificacy were first discovered. Originators of the Booroola Merino were the Seears Brothers; Messrs. Jack and Dick Seears, of “Booroola”, Cooma, who established, within their Egelabra flock, a multiple-birth group, selected on the ewe side only.

The Seears Brothers donated to CSIRO (Commonwealth Scientific and Industrial Research Organisation) two quintuplets rams in 1958 and 1959, and a sextuplet ewe in 1960. CSIRO purchased 12 triplet and quadruplet ewes in 1958, plus one with triplets at her first lambing. In 1965, a further group of 91 multiple-born ewes was purchased. Selection on both sexes has been practised with marked response.

The suggestion is made that, as the Egelebra stud can be traced back to the flocks of the Rev. Samuel Marsden, they may carry genes

derived from the first sheep breeds in New South Wales (Cape or/and Bengal), which are the early records to be prolific (Turner, 1982).

The mutation has recently been found in native sheep breeds in India, China and Indonesia and it's likely that the FecB in Australian Booroola Merino was derived from importation of Garole sheep from India in 1792 and 1793 (Notter, 2008; Fogarty, 2009).

b) Booroola genotype

The FecB (Booroola) mutation in sheep results in dysregulation of the normal mechanisms of follicles election in this species and has been the subject of intensive research for more than 30 yr (Bindon, 1984; McNatty et al., 2004; Campbell et al., 2007).

The fecundity gene, FecB, was the first major gene for prolificacy identified in sheep (Gootwine et al., 2008). It is a single autosomal locus, which causes higher prolificacy in sheep and was mapped to a narrow region (around 4 cM) on sheep chromosome 6 (6q23-31) using polymorphic microsatellites and known gene markers (Wilson et al., 2001; Liu et al., 2003). The region is homologue to human chromosome 4 (4q21-25) (Montgomery et al., 2002; Montgomery et al., 2003).

Figure 11. The comprehensive map of sheep chromosome 6 and the lod 3 support region for Fec B. Intermarker distances are also shown in kosambi cM. Chromosome 6 marker data from the Booroola half-sib families, backcross families, and from the international mapping flock were combined, and a comprehensive linkage map created using CRI-MAP (Wilson et al., 2001)

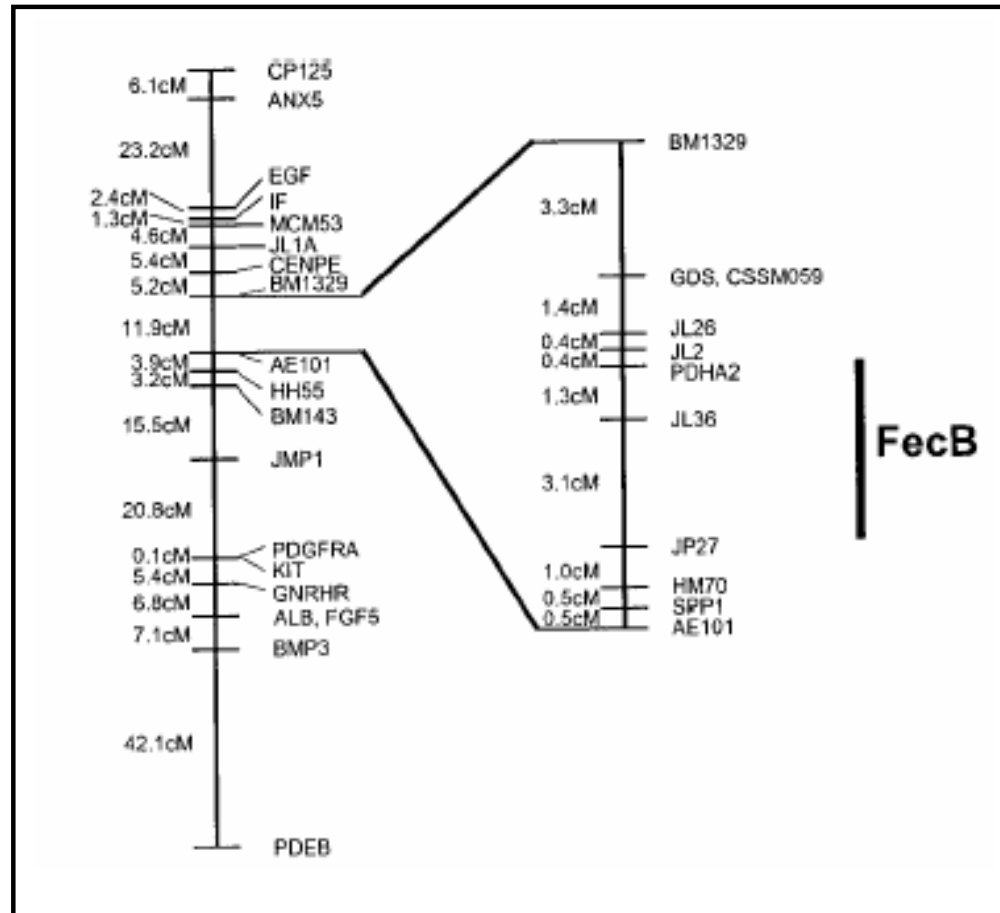

The Fec B locus is situated in the region of ovine chromosome 6q23-31 corresponding to the human chromosome 4q22-23, (Pardeshi et al., 2005; Chu et al., 2007).

In Fec B animals, a single A to G substitution at nucleotide 746 of BMPR 1B cDNA resulting in the non conservative substitution Q249R (arginine replacing a glutamine) in a highly conserved intracellular kinase signalling domain of the receptor protein (Wilson et al., 2001; McNatty et al., 2001; Feng et al., 2007).

The BMPR 1B receptor protein is expressed in oocytes in primordial and pre-antral follicles and in granulosa cells from the primary stage of growth as well as in corpora lutea. Ewes carrying the FecB^B mutation are characterized by 'precocious' differentiation of ovarian follicles associated with an earlier proliferation and differentiation of granulosa cells (Driancourt et al., 1985; Henderson et al., 1987; Gonzales-Bulnes et al., 2007) leading to the production of large numbers of ovulatory follicles that are smaller in diameter than wild-type follicles (Souza et al., 2003).

Figure 12. Schematic representation of the effects of a mutation in fecundity (Fec) gene, on folliculogenesis and ovulation rate, in sheep. (Fabre et al., 2006)

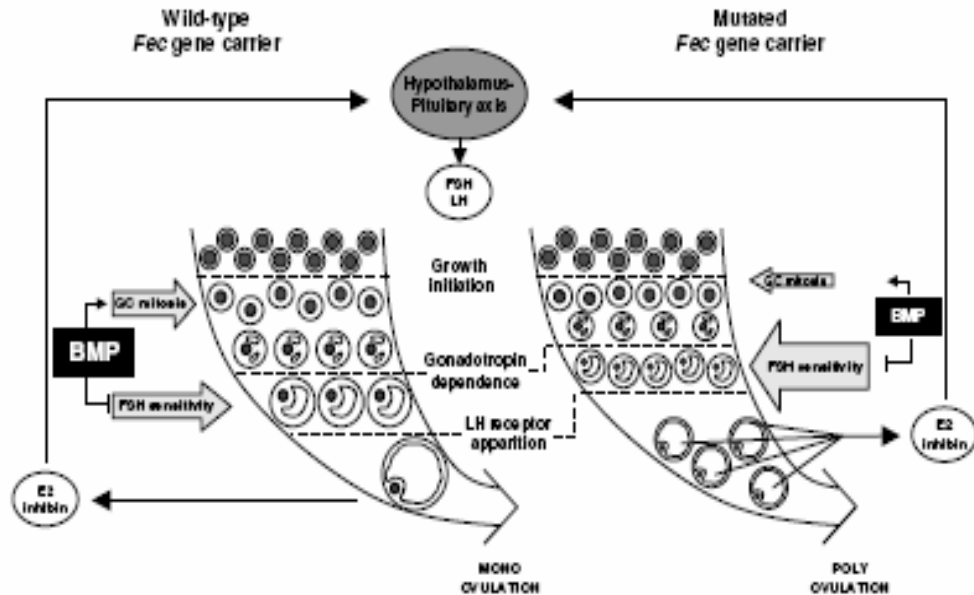

This mutation can be detected directly by forced PCR restriction fragment length polymorphism (PCR-FRFLP) approach based on the reports described by Souza et al. (2001) and Davis et al. (2002).

It has been reported that the effect of the Booroola allele ($FecB^B$) is additive for ovulation rate and each copy of the allele increases ovulation rate by about 1.6 and approximately one to two extra lamb in Booroola Merino (Guan et al., 2005; Kumar et al., 2008).

No major effects on the $FecB$ mutation have been observed in males (Smith et al., 1996).

4.4 Mutation on Bone Morphogenetic Protein 15 (GDF9B)

In recent years, many studies on the genetics of prolificacy in sheep lead to highlight the importance of major genes other than *BMP1B*, namely *BMP15* and *GDF9*, which have been shown to affect litter size and ovulation rate through different mechanisms (Davis, 2005).

The Bone Morphogenetic Protein 15 (*BMP15*) is a growth factor and a member of the TGF β superfamily that is specifically expressed in oocytes.

Sheep *BMP15* gene maps to chromosome X, the full length coding sequence of 1179 nucleotides is contained in two exons, separated by an intron of about 5.4 kb, and encodes a prepropeptide of 393 amino acid residues. The active mature peptide is 125 amino acids long. (Hanrahan et al., 2004).

Figure 13. Best position genetic linkage map of the sheep X chromosome. Distances are in cM and were estimated using the Kosambi mapping function (Galloway et al., 2002)

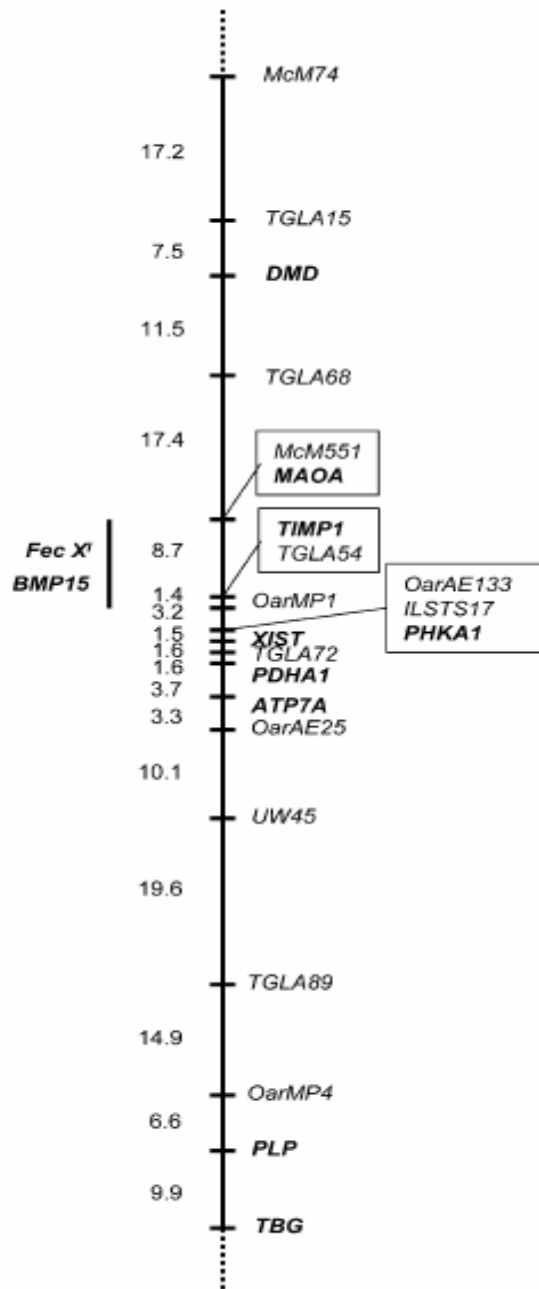

BMP15 regulates granulosa cell proliferation and differentiation by promoting granulosa cell mitosis, suppressing follicle-stimulating hormone receptor expression and stimulating kit ligand expression, all of which play a pivotal role in female fertility in mammals (Juengel et al., 2002; Moore and Shimasaki, 2005; Chu et al., 2007).

BMP15 is produced as precursor protein with the biologically active portion of the protein residing in the C-terminus.

Six mutations, labelled FecX^R (Rasa Aragonesa) (Monteagudo et al., 2009), FecX^H (Hanna) and FecX^I (Inverdale) (Galloway et al., 2000), FecX^L (Lacaune) (Bodin et al., 2007), FecX^G (Galway) and FecX^B (Belclare) (Hanrahan et al., 2004) have been detected so far within the BMP15 gene. All these mutations show the same phenotype: homozygous carrier ewes are sterile due to ovarian hypoplasia caused by the inability of ovarian follicles at the primary stage to develop, heterozygous carriers show increased ovulation rate, between 0.8 and 2.4 above that of the respective non-carrier flocks (Davis et al., 2006; Monteagudo et al., 2009).

Two of the five BMP15 mutations have premature stop codons, one of these (FecX^G in Belclare and Cambridge sheep) is at amino acid position 29 in the proregion of exon 2 before the mature region, thus no mature protein is produced and the other is the Hanna mutation (FecX^H), which is a V31D substitution at amino acid 23 of the mature

protein rendering it inactive. Another two mutations are nonconservative amino acid substitutions within the mature protein at amino acid positions 31 (Inverdale; FecX^I) and S99I substitution at amino acid 99 (Belclare; FecX^B). The fifth identified mutation has been reported in Lacaune ewes. This mutation was found as a co-dominant mutation in an animal with an autosomal gene, localized in the chromosome 11 and affecting ovulation rate.

Inverdale gene as the second major gene affecting ovulation rate

The inheritance pattern of the Inverdale gene (FecX^I) was discovered in 1990 in a screened prolific flock among descendants of Romney ewe, which had produced 33 lambs in 11 lambing in a Banks Peninsula flock. In the mid 1990's in the Romney flock of Mac Hanna in Waikato, a gene showing the same inheritance pattern and phenotype as Inverdale was found (Davis et al., 2001).

The observation that in both Inverdale and Hanna sheep a carrier ram passed the gene to all daughters but to none of his sons was the first indication that in both flocks a prolificacy gene was inherited on the X chromosome. In contrast, carrier ewes passed the gene to half their progeny of each sex (Davis, 2004).

One copy of the Inverdale (FecX^I) allele or Hanna (FecX^H) allele increase litter size by about 0.6 lambs per ewe lambing. However, homozygous ewes inheriting alleles from both parents have small

undeveloped ovaries and are infertile (Liu et al., 2003; Hanrahan et al., 2004; Chu et al., 2005; McNatty et al., 2005; Bodin et al., 2007).

The FecX I+ (single copy of the gene in heterozygosis) ewes appear indistinguishable from their non-carrier counterparts, but infertile FecX II (homozygous) ewes show severe disruption of their normal ovarian function and have ovaries which are “streak-like” in appearance (Galloway et al., 2002).

In the late 1990's, a DNA marker test for the Inverdale gene was developed and had a similar accuracy to the early Booroola marker test (Galloway et al., 1999). The test also relied on three DNA markers and needed information on the Inverdale status of parents of the sheep under test. In 2000, research at the Ag Research Molecular Biology Unit in collaboration with researchers at Wallaceville and Finland, showed that Inverdale sheep have a mutation in an ovary-derived growth factor gene (BMP15).

The FecX^R Rasa Aragones genotype

Monteagudo et al. (2008) presented a novel mutation in the second exon of the ovine BMP15 gene, found in the Spanish breed Rasa Aragonesa. It consists of a 17 bp deletion resulting in displacement of the open reading frame and premature stop codons. As a consequence, nearly 85% of the sequence of the wild type aminoacidic chain in the second exon of the BMP15 pro-protein is modified or suppressed as

only the first 45 amino acids are conserved of the 245 original. The mature peptide is lost. The ewes heterozygous for this deletion present very high prolificacy (2.66 lambs/birth) when compared to a mean flock prolificacy of 1.36 lambs. The deletion causes a complete lack of functionality of the second exon of BMP15, comparable to the effect of premature stop codons in other mutations. Therefore, homozygous females for the deletion are expected to present primary ovarian failure. This mutation was named FecX^R as it is described in the Rasa Aragonesa breed.

4.5 Mutation on Growth Differentiation factor 9 (GDF9)

GDF9 is a growth factor and is also a member of TGFβ superfamily that is secreted by oocytes in growing ovarian follicles (Nilson et al., 2002). Bodensteiner et al. (1999) reported the nucleotide sequence of the ovine GDF9 gene (GenBank accession number AF078545). Sheep GDF9 was mapped to chromosome 5, (Sadighi et al., 2002). Like the human and mouse genes, ovine GDF9 spans approximately 2.5 kilobases (kb) and contains 2 exons separated by a single 1126-base pair (bp) intron. GDF9 is produced as precursor and encodes a prepropeptide of 453 amino acid residues. The active

mature peptide is 135 amino acids long. (Bodensteiner et al., 1999; Juengel et al., 2004). GDF9 is essential for ovarian follicular development and normal ovulation and/or corpus luteum formation in sheep (Knight and Glister, 2006). GDF9 mRNA and protein are present in germ cells during follicular and in oocytes of primordial follicles and at all subsequent stage of follicular growth (Juengel et al., 2002).

Eight single nucleotide polymorphisms have been identified so far in sheep GDF9, indicated G1 to G8. Only the G8 change has been associated with the prolificacy phenotype, it was labeled FecG^H (High Fertility). The FecG^H allele corresponds to a C/T transition at nt 1184 of the cDNA, leading to the aminoacid substitution S395F in GDF9 protein, or to the aminoacid position 77 of the mature protein region (Moore et al., 2004). The ovarian phenotype in animals homozygous for this mutation is different than that for the BMP15 mutations in that ovarian follicles continue to develop to the antral stages although most, if not all, are abnormal with respect to oocyte morphology and the arrangement and appearance of the granulosa and cumulus cell-types (McNatty et al., 2005).

Animal homozygous for this mutation are anovulatory and thus sterile, whereas heterozygous animals have means ovulation rates about 2.0 greater than that the wild type (McNatty et al., 2005).

Figure 14. Linkage map position GDF9 in the central portion of the sheep chromosome 5 on the framework map. Map distances are kosambi centiMorgans

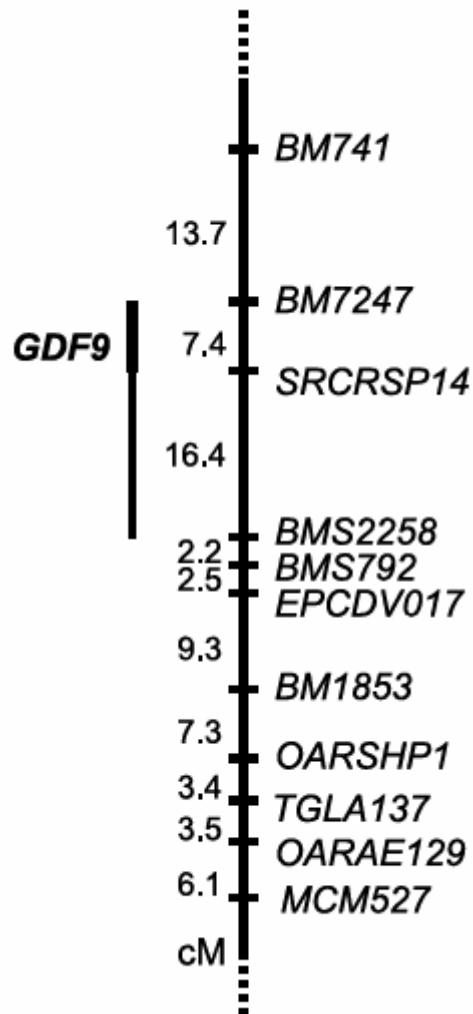

3.Aim of the Research

Aim of the research

Sheep occupy a special niche in the Tunisian agricultural production system and are important for the rural economy. Genetic improvement of sheep for meat production is one of the important development priorities. Enhancing reproductive rate is a logical approach to improve economic efficiency of meat production by producing more lambs from the same number of ewes.

High prolificacy is a desirable trait in sheep raised under intensive management systems where adequate care is provided for the ewes and their lambs (Gootwine et al., 2007), so one approach to identify factors regulating ovulation rate is to find mutations that influence the target phenotype.

Genetic mutations with major effects on ovulation rate and litter size in sheep were recently identified in three genes belonging to the TGF β superfamily: the BMP receptor type 1B, the bone morphogenetic protein15 (BMP15) and the growth differentiation factor (GDF9) (Bodin et al., 2007).

Several breeding programmes are currently active in Tunisia for the genetic improvement of meat sheep, where the objective of selection is the improvement of meat quality, growth performance, adaptation to difficult environmental conditions and prolificacy (FAO, 2007). In

this context, information about sheep genotype in relation to major genes affecting prolificacy would be of great interest. The aim of this research was to investigate the genetic structure of *BMPR 1B*, *BMP15* and *GDF9* genes in five sheep breeds reared in Tunisia.

4. Materials and Methods

Materials and methods

1. Animals

Five Tunisian sheep breeds were tested for the presence of genes with large effects on ovulation rate. The breeds used were Barbarine, Noir de Thibar, Sicilo-Sarde, Queue Fine de l'Ouest and D'man.

The experimental procedures reported in this study were carried out on 204 representative animals belonging to 5 farms, from different areas of Tunisia, not derived from Booroola strains, with data on litter size in the first, second and third parity. Barbarine and Queue Fine de l'Ouest animals were from the north east (Zaghouan), Noir de Thibar and Sicilo-Sarde were from the north west (Beja) and D'man animals were from the south (Gabes) of Tunisia. The ewes of the Barbarine, Queue Fine de l'Ouest, Noire de Thibar and Sicilo-Sarde breeds were chosen at random from flocks of 180 to 250 ewes, and were the progeny of 8-20 rams. Part of the D'man ewes were chosen at random from a flock of 100 ewes, sired by 5 rams; the sampled D'man sheep also comprised the 5 rams, their daughters (three for each ram), and the dam of each daughter.

2. Blood samples collection and DNA extraction

Venous jugular blood samples were collected in 10 ml vacutainers tubes using Na₂EDTA as an anticoagulant. Genomic DNA was extracted from leucocytes with a commercial kit (Puregene, GENTRA) and kept at -20°C.

DNA concentration and purity were evaluated by determination of the spectrophotometric absorbance at wavelength $\lambda = 260$ and of the 260/280 ratio, respectively.

3. Genotyping

3.1.1 BMPR 1B gene

The FecB (Booroola) mutation is due to an A/G transition at position 830 of BMPR 1B cDNA, causing a Gln/Arg change at residue 249 of the protein. This mutation was investigated by means of PCR-Forced Restriction Fragment Length Polymorphism (PCR-FRFLP). The method involves amplification of a 140 bp long DNA region, spanning the 6th exon of BMPR 1B gene, with the primer pair

F12/FRFLP (all the primer pairs utilised are described in Table 2). The sequence of the reverse primer is modified in order to introduce a restriction site for the *AvaII* enzyme, which allows the identification of the Booroola genotype, PCR products from non carriers lack this site (Wilson et al., 2001).

Genomic DNA was amplified in 25 µl reaction volume. For the reaction, 25-50 ng genomic DNA were amplified with 0.2 µM each primer, 1,5 mM MgCl₂, 0,2 mM dNTPs, 1X reaction buffer (20mM Tris-HCl, pH 8.4, 50mM KCl) and 1U Taq Polimerase (Platinum[®] *Taq* DNA Polymerase, Invitrogen).

PCR thermal conditions, performed on a Mastercycler[®] epGradientS Thermal Cycler (Eppendorf), consisted of an initial denaturation step at 94°C for 2,30 minutes, followed by 31 cycles at 94°C for 20 seconds, 63°C for 30 seconds and 72°C for 10 seconds, and concluded with a final extension step at 72°C for 10 minutes. The PCR product (20µl) was digested with *AvaII* restriction enzyme at 37°C for 2 h and the resulting products were separated on a 2.0% agarose gel, visualised with ethidium bromide and detected by UV transilluminator.

3.1.2 Analysis of the sequence variability of BMPR 1B 5' and 3' flanking regions

PCR primers specific for the sheep BMPR 1B gene were designed using the Primer 3 software (<http://frodo.wi.mit.edu/primer3/>). PCR primer pair targeting the sheep promoter region were designed based on the bovine BMPR 1B gene retrieved from the Ensemble Genome Browser (<http://www.ensembl.org/>), while the two primer pairs targeting the sheep 3'UTR were designed based on the GenBank acc. no. AF357007. The specificity of the primer pairs designed in our laboratory was tested by sequencing the amplification product.

PCR was performed in a reaction mixture of 25µl final volume, using the same reaction conditions as those previously reported for the FecB mutation detection, except for the annealing temperatures which were: 61° C, 59° C and 55° C for Cow1F/R, BoncF/R and Bo13F/R primer pairs respectively.

The putative regulatory motifs were searched by AliBaba 2.1 software (<http://www.gene-regulation.com/pub/programs.html>).

Table 2
Primer sequences used for PCR and for SSCP analysis

Gene	Primer name	Primer sequence (5'-3')	Reference	DNA analysis
BMPR 1B	F12	GTCGCTATGGGGAAGTTTGGATG	Wilson et al., 2001	PCR-FRFLP*
	FRFLP	CAAGATGTTTTTCATGCCTCATCAACACGGTC		PCR-SSCP**
	BONCF	5'-TCCCAGGACATTAAGCTCTGA-3'	This research	PCR-SSCP
	BONCR	5'-AAGGCAATCCCAAAATACCG-3'		
	BO13F	5'-TGACAGCCCTACGGGTAAAG-3'	This research	PCR-SSCP
	BO13R	5'-ATGAGGAATCCGTGCTTCTG-3'		
	COW1F	5'-GGTTTATGAGAACTTCTAGTGAGACCT-3'	This research	PCR-SSCP
	COW1R	5'-CTTCTTGGTGCCACACTT-3'		
BMP15	UpperF	CATGATGGGCCTGAAAGTAAC	Davis, 2002	PCR-SSCP
	LowerR	GGCAATCATACCCTCATACTCC		
	MP15F	CTCTGAGACCAAACCGGGTA	Monteagudo et al., 2009	PCR PCR-SSCP
	MP15R	CATGCCACCAGAACTCAAGA		
	B2F	CACTGTCTTCTTGTTACTGTATTTCAATGAGAC	Hanrahan et al., 2004	PCR-FRFLP PCR-SSCP
	B26R	GATGCAATACTGCCTGCTTG		
	B4F	GCCTTCCTGTGTCCCTTATAAGTATGTTCCCCTTA	Hanrahan et al., 2004	PCR-FRFLP PCR-SSCP
	B4R	TTCTTGGGAAACCTGAGCTAGC		
GDF9	G7F	GCCTCTGGTTCCAGCTTCAGTC	Hanrahan et al., 2004	PCR-FRFLP PCR-SSCP
	G7R	CAGTATCGAGGGTTGTATTGTGTGGGGCCT		
	G8F	CTTTAGTCAGCTGAAGTGGGACAAC	Hanrahan et al., 2004	PCR-FRFLP PCR-SSCP
	G8R	ATGGATGATGTTCTGCACCATGGTGTGAACCTGA		

*Polymerase Chain Reaction-Forced Restriction Fragment Length Polymorphism

**PCR-Single Strand Conformation Polymorphism

3.2 BMP15 gene

The FecX^R allele is characterized by a 17 bp deletion in the second exon of the ovine BMP15 gene. This variation was investigated by PCR utilizing primer pair MP15F/MP15R (Monteagudo et al., 2009). A 312 bp amplification product is expected from the wild type sequence, while the FecX^R variant gives a 295 bp long product.

The FecX^H, FecX^I and FecX^L alleles were investigated by PCR-SSCP utilizing the primer pair UpperF/LowerR (Davis et al., 2002). This primer pair amplifies a DNA region of 312 bp localized in the second exon of the BMP15 gene, spanning from nt 850 to nt 1161 of cDNA, in which these mutations are localised.

PCR-FRFLP method was also used to investigate the FecX^G (primer pair B2F/B2R) and FecX^B (primer pair B4F/B4R) mutations, which includes digestion with restriction enzymes HinfI and DdeI respectively. The FecX^G mutation is due to a C/T transition at nucleotide 718 of BMP15 cDNA, which leads to the formation of a premature stop codon instead of the 239 coding residue Gln (Q).

The FecX^B mutation is characterized by the G/T transversion at nucleotide 1100 of the BMP15 cDNA, causing the aminoacid change Ser (S)-Ile (I) at the coding residue 367, which corresponds to the mature peptide residue 99 (Hanrahan et al., 2004).

3.3 GDF9 gene

The FecG^H (also known as G8) mutation is due to a C/T transition at nucleotide 1184 of GDF9 cDNA, which causes an aminoacid change at the coding residue 395, corresponding to residue

77 of the mature peptide. The FecG^H mutation was investigated by PCR-FRFLP utilizing the primer pair G8F/G8R, the restriction enzyme was DdeI. In order to obtain further information about GDF9 gene variability in North African sheep breeds, the G7 mutation was also investigated by PCR-FRFLP utilizing the primer pair G7F/G7R and the restriction enzyme MseI, although this mutation is considered not to affect fertility. This mutation is characterized by a G/A transition at nucleotide 1111 of GDF9 cDNA, causing the aminoacid change Val (V)-Met (M) at the coding residue 371, which corresponds to the residue 53 of the mature peptide (Hanrahan et al., 2004).

4. Sequencing

The identity of DNA fragments from 10-20 DNA samples of each genotype was confirmed by direct sequencing in both forward and reverse directions. Thirty µl of each PCR product were purified with the ChargeSwitch[®] PCR Clean Up Kit (Invitrogen) and eluted in 30 µl of TE buffer. Sequencing was performed on an ABI 3730 XL DNA sequencer (Applied Biosystem). Analysis of nucleotide sequences and deduced aminoacid sequences was performed with Bioedit (www.mbio.ncsu.edu/BioEdit/) software. Comparison among

sequences and multiple alignments were accomplished using ClustalW software (<http://align.genome.jp/>).

5. SSCP analysis

The sequence variability of all the described DNA segments utilised for genotyping was further investigated by Single Stranded Conformation Polymorphism (SSCP). All the SSCP analysis were carried out on a D-Code Universal Mutation Detection System (BioRad), as follows: 2.5 µL of PCR product was added to 7.5 µL of denaturing solution (1mg/ml xylene-cyanol, 1mg/ml bromophenol blue, and 10mM EDTA in 80% deionized formamide). After denaturation at 94° C for 3 min, the samples were rapidly chilled on ice and then run on acrylamide: bisacrylamide gels (37,5 : 1) in 0.5× Tris-borate-EDTA (TBE) buffer, at 25 W. Gel concentration ranged from 8% to 12%; time of the run ranged from 2 to 8 hours and the controlled temperature of the run was 12° C to 15° C. The DNA fragments showing different patterns on SSCP gels were sequenced. Analysis of nucleotide sequences and deduced aminoacid sequences was performed with Bioedit software (www.mbio.ncsu.edu/BioEdit/).

6. Statistical Analysis

Genotypic data were analyzed with the GenePop software (<http://genepop.curtin.edu.au/>) for allele and genotype frequencies and Hardy-Weinberg equilibrium.

4. Results and Discussion

Results and discussion

1. Sheep prolificacy

Mean litter size of the analysed subjects averaged from 1.14 (Queue Fine de L'Ouest) to 2.72 (D'man) (Table 3). In the Queue Fine de L'Ouest, Noire de Thibar and Sicilo-Sarde breeds, litter sizes were up to 2; in the Barbarine breed only one subject (4207) gave litters of three lambs; conversely, 54% of D'man breed ewes considered in this research gave litters of 3 or 4 lambs.

Table 3. Mean litter size, sampling site and breed origin of tested sheep and of the breed

Breed	No. tested ^a	Mean litter size ^a	Sampling site ^a	Breed mean litter size
Barbarine	41	1.24	Zaghouan	1.17 ^b
Queue Fine de l'Ouest	31	1.14	Zaghouan	1.19 ^b
Noire de Thibar	34	1.32	Beja	1.21 ^b
Sicilo-Sarde	51	1.52	Beja	not available
D'man	47	2.72	Gabes	1.53 – 2.27 ^c

^a sheep tested in this research; ^b(Rekik et al., 2005); ^c(Darfaoui, 1999)

2. Genotyping of *BMPR 1B*, *BMP15* and *GDF9*

Genotyping revealed that the investigated mutations at the *BMPR 1B*, *BMP15* and *GDF9* genes were absent in all five breeds analysed (Table 4).

Table 4. Genotyping and SSCP analysis of the 204 sheep analysed

Gene	Primer pair	Allele	Genotype	SSCP
<i>BMPR 1B</i>	F12/FRFLP	FecB ^B	++	no variation
<i>BMP15</i>	UpperF/LowerR	FecX ^H , FecX ^L , FecX ^L	++	no variation
	MP15F/MP15R	FecX ^R	++	no variation
	B2F/B2R	FecX ^G	++	variation
	B4F/B4R	FecX ^B	++	variation
<i>GDF9</i>	G7F/G7R	G5, G6, G7	++	no variation
	G8F/G8R	FecG ^H	++	no variation

2.1 *BMPR 1B*

In figure Xa is represented the result of PCR-FRFLP analysis of the 6th exon of *BMPR 1B* gene, the *AvaII* digestion performed in this region allows to detect the presence of the A nucleotide, characterizing the FecB⁺ allele, or the presence of the G nucleotide, characterizing the FecB^B allele, at position 161 of the 6th exon. PCR-

FRFLP analysis at the *BMPR 1B* gene revealed that the *FecB* (Booroola) mutation was absent in all five breeds analysed. The DNA fragment amplified with the F12/FRFLP primer pair was also analysed by SSCP, with the aim of detecting any polymorphism occurring within the entire sequence, but this search also did not reveal any variation (Figure 15).

Figure 15. Analysis of DNA fragments amplified with the primer pairs specific for the *BMPR 1B* gene

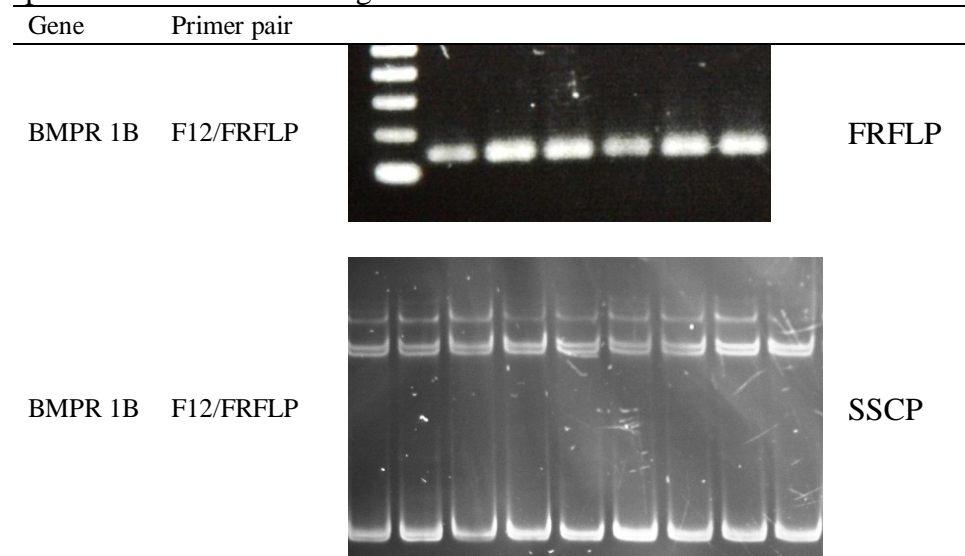

This result was confirmed by sequencing twenty randomly chosen DNA samples, in both forward and reverse directions. All sequences corresponded to the Acc. No. AF312016. The *FecB^B* allele has been detected so far in many prolific breeds such as the Indian Garole, the Indonesian Javanese sheep (Davis et al., 2002), and in the

Chinese highly prolific breeds Hu, Huiyang, Small Tailed Han and Chinese Merino prolific strain, considered as having a common origin with the Australian Booroola Merinos (Davis et al., 2006). Several investigations show that the $FecB^B$ allele is absent in low prolific sheep breeds (Chu et al., 2007; Hua et al., 2009), but it is also absent in many prolific sheep, such as Olkuska, Thoka and Woodlands breeds, where the high prolificacy phenotype is probably due to the effect of major genes other than *BMPR 1B*, *BMP15* or *GDF9* (Davis, 2005). As in the four Tunisian sheep breeds, also in the D'man breed, in which we had subjects with litter sizes of up to 4, the $FecB^B$ allele was not detected. Similar results have also been reported for highly prolific D'man ewes reared in Morocco (Davis et al., 2006).

2.2 *BMP15*

The $FecX^R$ genotype, found in the Rasa Aragonesa breed, is characterized by the deletion of 17 bp in the second exon of the *BMP15* gene. Ewes heterozygous for this deletion have very high prolificacy: up to 2.66 lambs/birth (Martinez-Royo et al., 2008; Monteagudo et al., 2009). Agarose gel electrophoresis did not reveal any size variation within this amplicons in the 204 analysed subjects.

We always obtained a 312 bp long fragment, instead of 295 bp (Figure Xa).

The genotypes $FecX^H$, $FecX^I$ and $FecX^L$ (Figure 16a) were investigated by SSCP utilising the UpperF/LowerR primer pair (Davis et al., 2002), which amplified a 311 bp long DNA region in the second exon of the BMP15 gene (nt 850-1161 of cDNA). The $FecX^H$ genotype is due to a C/T transition at nt 871 of the coding sequence. The Inverdale $FecX^I$ allele, identified in a flock of Romney sheep in New Zealand (Davis et al., 1991), is due to the transition T/A at nt 896 of the BMP15 cDNA sequence (Fabre et al., 2006; Galloway et al., 2000). The $FecX^L$ (Lacaune) genotype is due to a G/A transition at nt 962 of the cDNA (Bodin et al., 2007). The SSCP analysis of the DNA samples amplified with the UpperF/LowerR primer pair did not reveal any variation within this amplicon. This result was confirmed by sequencing twenty randomly chosen DNA samples in both forward and reverse directions. All sequences corresponded to the Acc. No. AF236079.

Figure 16 (next page). Analysis of DNA fragments amplified with the primer pairs specific for the BMP15 gene. The DNA sample in picture (c) lane 4 is from ewe 1255 (Noir de Thibar breed) carrying the B3 mutation in heterozygosis. The DNA sample in picture (d) lane 4 is from ewe 2094 (Barbarine breed) carrying the B5 mutation in heterozygosis.

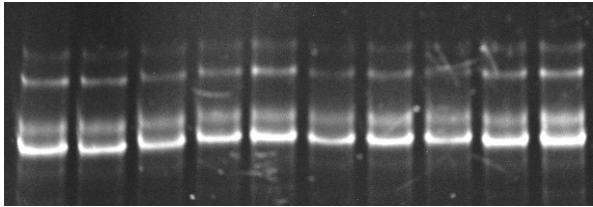
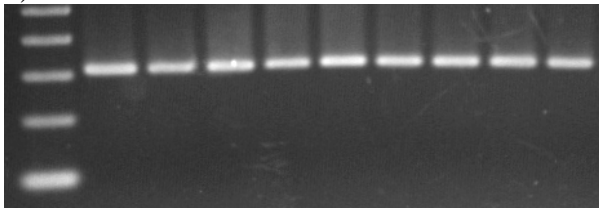
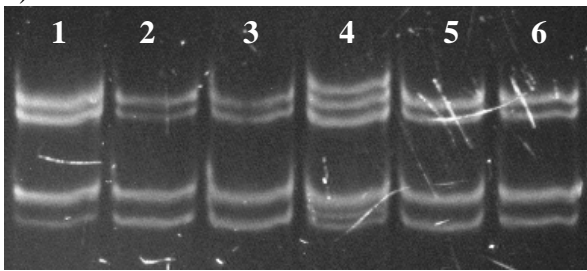
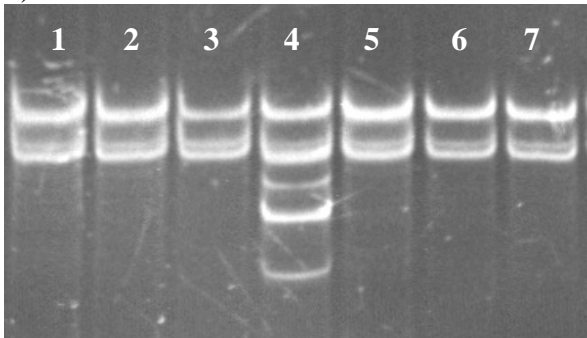
Gene	Primer pair		
		a)	
BMP15	UpperF/LowerR		SSCP
		b)	
BMP15	MP15F/MP15R		PCR
		c)	
BMP15	B2F/B2R		SSCP
		d)	
	B4F/B4R		SSCP

The $FecX^G$ genotype is caused by the mutation C/T at nt 718 of the BMP15 gene and it was first evidenced in the Belclare and Cambridge breeds (Hanrahan et al., 2004). We did not find any subject carrying the $FecX^G$ genotype. The 141 bp amplicon produced by the primer pair B2F/B2R was also analysed by SSCP (Figure 16c). This analysis revealed the presence of one subject (ewe no. 1255, Noir de Thibar breed) showing a different band pattern compared to all the other samples. Sequencing in both forward and reverse directions of the differing sample revealed the occurrence of the B3 mutation, corresponding to a T/C transition at nt 747 of BMP15 cDNA, in heterozygosis. Sequencing of twenty samples, all showing the same banding pattern, revealed that they had the same sequence of the Acc. No. AF236079.

The 1255 ewe gave a mean litter size = 1, confirming the results obtained for other breeds, such as F700-Belclare (Hanrahan et al., 2004) where this mutation does not affect prolificacy.

Another important genotype of BMP15 gene is $FecX^B$, which corresponds to a G/T transversion at nt 1100 of the BMP15 cDNA. No subject carrying this mutation was found in the population analysed. The SSCP analysis of the 153 bp long DNA fragment amplified with the primer pair B4F/B4R revealed the presence of sequence variability

only in one subject (ewe no. 2094) showing a polymorphic pattern different from all the others (Figure 16d).

Sequencing of the DNA sample of the no. 2094 ewe revealed the occurrence of a nucleotide change GCC/ACC at nt 1159 of BMP15 cDNA in heterozygosis (Figure 17), causing the aminoacid change Ala119Thr in the mature peptide (Figure 18). The sequence was submitted to the GenBank database and was given accession number GU117618. Sequencing of twenty randomly chosen DNA samples showing the same SSCP pattern, showed that they corresponded to the published sequence: Acc. No. AF236079. The no. 2094 ewe was from the Barbarine breed, and it gave a litter size of 1 lamb. The only Barbarine ewe (no. 4207) of our sample giving litters of up to three did not carry this allele. This mutation, which we label B5 (following nomenclature of Hanrahan et al., 2004), presumably replaces an hydrophobic non polar group (Ala) with an uncharged polar group (Thr) at residue 119 of the mature peptide. For this reason, it is likely to affect the activity of the mature protein. In this case, it is necessary to carry out further studies in order to better understand the importance of this mutation, which has never been described in other breeds.

Figure 17. Nucleotide substitution of the BMP15 B5 mutation compared with wild-type sheep sequence.

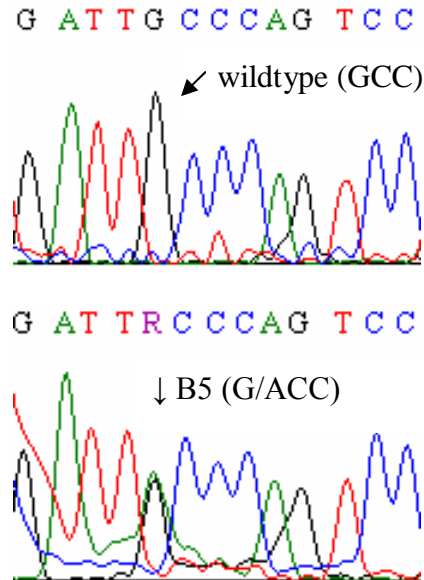

Fig. 18. Barbarine sheep BMP15 sequence. Putative sequence of sheep BMP15 protein. Numbers in parentheses indicate amino acid positions in the mature peptide. The filled triangle separates aminoacids encoded by the first and by the second exon. The position of the B2 (FecX^G) and B4 (FecX^B) mutations associated with sterility are underlined (Hanrahan et al., 2004). The position of the B5 mutation is underlined and bolded.

1	MVLLSILRIL	LWGLVLFMEH	RVQMTQVGQP	SIAHLPEAPT	LPLIQELLE
51	APGKQQRKPR	VLGHPLRYML	ELYQRSADAS	GHPRENRTIG	ATMVRLVRPL
		▼			
101	ASVARPLRGS	WHIQTLDFPL	RPNRVAYQL	VRATVVYRHQL	HLTHSHLSCH
151	VEPWVQKSPT	NHFPSSGRGS	SKPSLLPKTW	TEMDIMEHVG	QKLWNHKGRR
					Q239Ter[B2]
201	VLRLRFVCQQ	PRGSEVLEFW	WHGTSSLDTV	FLLLYFNDTQ	SVQKTKPLPK
			(1)		
251	GLKEFTEKDP	SLLLRARQA	GSIASEVPGP	SREHDGPESN	QCSLHPFQVS
301	FQQLGWDHWI	IAPHLYTPNY	CKGVCPRVLH	YGLNSPNHAI	IQNLVSELVD
			S367I[B4]	A387T[B5]	(125)
351	QNVQPSCVP	YKYVPISILL	IEANGSILYK	EYEGMIAQSC	TCR

2.3 GDF9

The most important mutation of the GDF9 gene is G8 or FecG^H. This mutation was absent in all the analysed subjects. The 139 bp amplicon obtained with the G8F/G8R primer pair was further analysed by SSCP, but all the subjects showed the same banding pattern (Figure 19a). Sequencing in both directions of twenty randomly chosen samples revealed that the sequence corresponded to the published Acc. No. AF078545. The primer pair G7F/G7R were utilised to investigate the mutation G7 by PCR, but in this case also no subject carried the mutation. This amplicon also contains the nucleotide positions G5 and G6 (Hanrahan et al., 2004), but the SSCP analysis did not reveal any variation within this sequence (Figure 19b). Sequencing of twenty DNA samples in both directions revealed that the sequence corresponded to acc. No. AF078545.

Figure 19. Analysis of DNA fragments amplified with the primer pairs specific for the GDF9 gene.

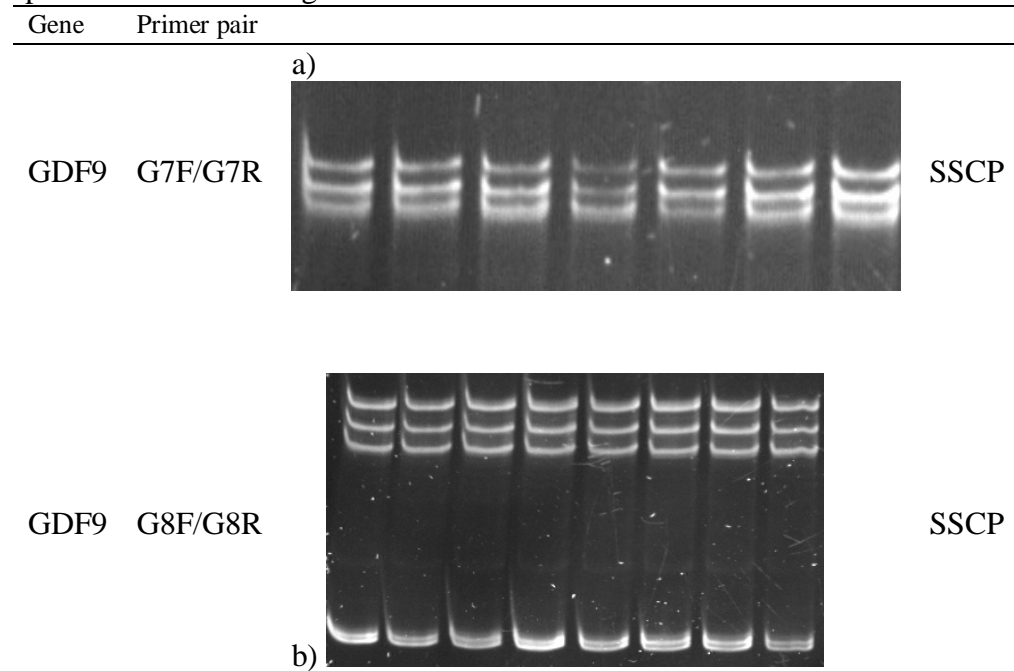

3. Variability of the 5' and 3' flanking regions of the *BMPR 1B* gene

The bone morphogenetic protein receptor 1B gene has not been sequenced yet in sheep, although it is known to be a major gene for prolificacy. For this reason, the primers for the promoter region were designed based on the bovine *BMPR 1B* sequence retrieved from the Ensembl Genome Browser (<http://www.ensembl.org/index.html>).

The bovine *BMPR 1B* gene extends over 51.94 kbp, including 3479 bp of exonic regions (corresponding to ten exons) and 48461 bp of intronic regions. The comparison between the sheep and cattle coding sequence reveals that they have the same structure. The similarity between the sheep coding sequence and the corresponding bovine sequence is 95%.

The investigation into the sixth exon of the *BMPR 1B* gene showed the absence of variability in the population analyzed. Therefore, for more information about the gene, we analyzed the 5' and 3' flanking regions, whose variability plays an important role in the regulation of expression and transcription of genes.

By using genomic DNA as template, we sequenced 227 nucleotides of the 5' flanking region and 279 nucleotides of the 3' flanking region, along with the partial sequence of the first and the tenth and last exon of the *BMPR 1B* gene. The resulting sequence is available on the GenBank database with accession number GU117619.

The comparison between the bovine and sheep promoter region is shown in figure 20.

Figure 20 (next page). Comparison of DNA sequence of the *BMPR 1B* promoter region from sheep and cattle. Number +1 indicates the beginning of the coding sequence. Stars indicate nucleotides identical between the two sequences. The first exon is underlined. The nucleotide variations occurring in the sheep sequence compared to the bovine one are bolded. Dashes indicate gaps, inserted to improve the alignments.

```

bovine          -172
                GGT T T T A T G A G A A C T T C T A G T G A G A C C T A T C T A T A T T G T A G A G A A A G T A T A G T T T T C A T A
ovine -227      GGT T T T A T G A G A A C T T C T A G T G A G A C C T A T C T A T A T T G T A G A G A A A G T A T A G T T T T C C A T A
                *****
                -164          -147   -141-137          -122-118
bovine          TC A G A A C A T C A G A A T G T G T T C T C T G T T T A T A T C T T T A A G T G T C A T G A A T A C T T A C T A T T T
ovine -167      TC A C A A C A T C A G A A T G T G T T T T C T C T G T A T G T C T T T A A G T G T C A C A A A T C C T T A C T A T T T
                *** ***** * * * * * ***** * * * *****
                -70          -55
bovine          T G T T T A A C A T C A T A A T T C T T T G G A C A G A A G A C T G T G G T T G G G C T A T C C C A A A T A T G C T T A
ovine -107      T G T T T A A C A T C A T A A T T C T T T G G A C A G A A G A C T G T G G C T G G G C T A T C C C A A A G A T G C T T A
                *****
                -46 -42          +1
bovine          A - - - - A T T C T T A C T C T T T C T C T T T T C A G C A A A C T T C C T T G A T A A C A T G C T T T T G C G A A
ovine -47      A G T T A A A T T C T T A C T C T T T C T T T T C A G C A A A C T T C C T T G A T A A C A T G C T T T T G C G A A
                *          *****

bovine          G T T C A G G A A A T T A A G T G T G G G C A C C A A G A A A
ovine +45      G T T C A G G A A A T T A A G T G T G G G C A C C A A G A A A
                *****

```

Compared to the bovine counterpart, the promoter sequence of the sheep *BMP1B* gene shows 11 Single Nucleotide Polymorphisms (SNP) and a 5 bp insertion corresponding to nucleotides – 46/–42 of the sheep sequence (Table 5).

Table 5. Sequence variations between cattle and sheep

Variation	Nucleotide positions
GTAA	-46/-42
T/G	-55
T/C	-70
A/C	-118
G/A	-122
T/C	-123
A/G	-137
T/G	-141
G/C	-143
C/T	-147
G/C	-164
T/C	-172

These sequence variations between the cattle and sheep promoter may affect putative binding sites for transcription factors (Figure 21).

Figure 21. Sheep promoter sequence with potential binding sites. Variations in relation to the bovine sequence are bolded and blue coloured. Potential binding sites are underlined.

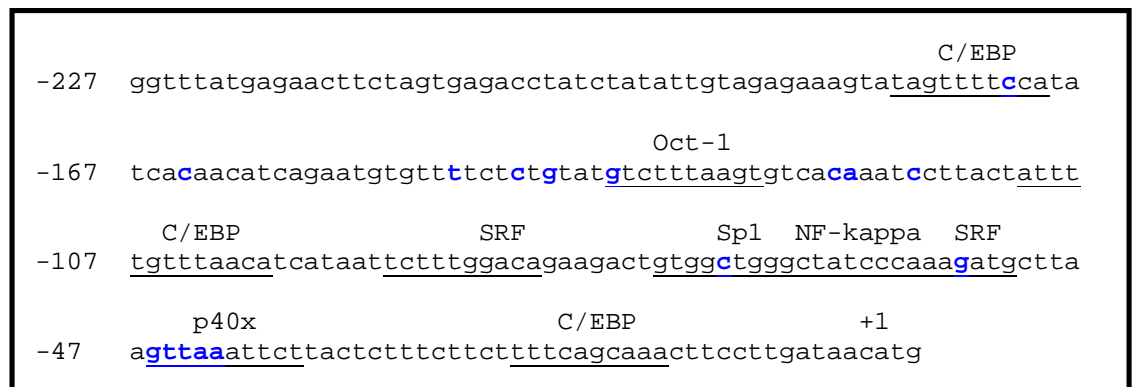

Apparently, the sheep *BMPR 1B* gene does not show a TATA Box within 25-30 nucleotides upstream of the first nucleotide of the first exon. In detail, the 5' end of the gene shows three CCAAT/enhancer binding protein (C/EBP, -14/-23, -99/-111 and -170/-179) sites (Raught et al., 1995), a p40x (-37/-46), and two SRF (-52/-61 and -82/-91). Other DNA cis-acting elements are a NF-kappa (-59/-68), a Sp1 (-65/-74) and a Nuclear Factor Octamer-1 (NF Oct-1) site located at -128/-137 (Bohmann et al., 1987).

In sheep DNA, as compared to cattle DNA, the two more proximal C/EBP sites and the SRF and NF-kappa sites appear to be more highly conserved than the others. In contrast, the 5 bp insertion (-42/-46) eliminates a TATA box and a potential binding site for TBP, which is recognized in the analysis of transcription factors putative binding sites of the bovine sequence (not reported).

In order to assess the degree of variability within the ovine species we performed an SSCP analysis of the promoter region of the *BMPR 1B* gene, applied to the 204 samples (five breeds). Results are shown in figure 22, where it is possible to see that no variation was found in this region. This result was confirmed by sequencing twenty randomly chosen DNA samples, in both forward and reverse directions. The absence of variability in the samples analysed evidences that this important regulatory region is highly conserved within this species.

Figure 22. SSCP of DNA fragments amplified with the primer pairs specific for the *BMPR 1B* 5' flanking region.

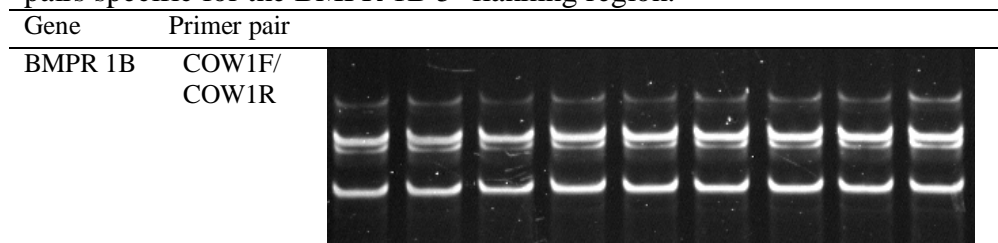

3' UTR region

In order to assess the degree of variability of the 3'UTR region (the transcribed but not translated region, within the 10th exon) PCR primers were designed based on the sheep *BMP1B* cDNA sequence (available on the GenBank database with acc. no. AF357007). The two primer pairs, which we labelled BoncF/BoncR and Bo13F/Bo13R, amplify two partially overlapping DNA fragments and allowed the sequencing of an overall 344 bp DNA fragment including 65 nucleotides of the 10th exon coding sequence and 279 nt of the 10th exon 3'UTR region. Two samples of each fragment were sequenced in both forward and reverse directions in order to test the specificity of the primers.

The PCR amplified DNA fragments were analyzed by SSCP, a method that has shown, as explained below, a high polymorphism level. The polymorphic profiles of the DNA fragment amplified with the primer pair BoncF/R are shown in figure 23. Four different conformation patterns are distinguishable in this picture, easily identifiable by the number of bands and their relative positions, which allow to group the samples of lanes 1, 2, 9, 10, characterized by two upper bands, samples in the lanes 3, 4, 5, 8, 11, showing four bands, while the sample in lane 6 with more than four bands and the subject in lane number 7 showing two lower bands.

Figure 23. SSCP of DNA fragments amplified with the primer pairs specific for the *BMPR 1B* gene.

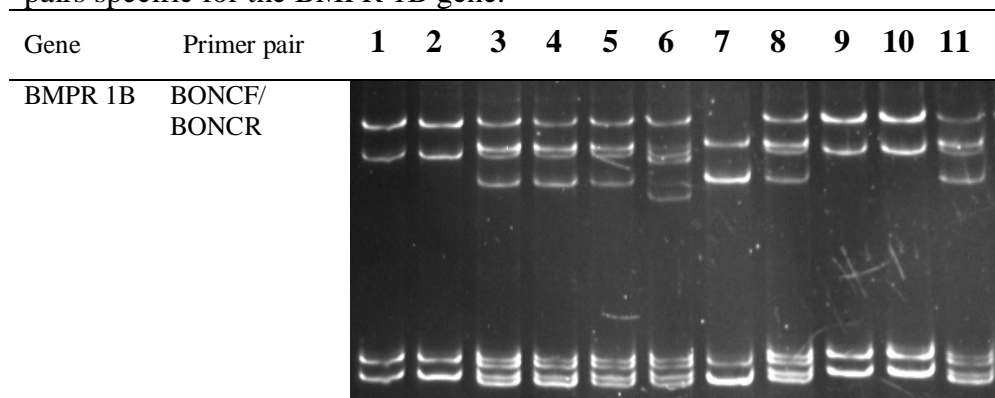

SSCP analysis of the fragment amplified with the primer pair Bo13F/R allowed to distinguish different single-stranded conformation patterns of DNA (Figure 24). The subjects in lanes 1, 4, 5, 6, 7, 8 and 11 show a banding pattern, which distinguishes them from samples in lanes 2, 3 and 9, and from the sample shown in lane 10.

Figure 24. SSCP of DNA fragments amplified with the primer pairs specific for the *BMPR 1B* gene.

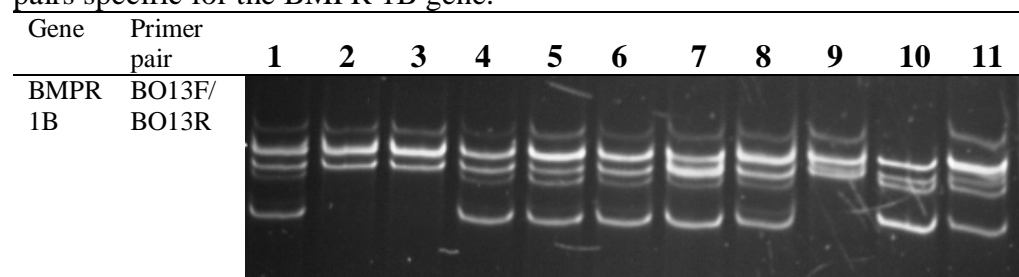

Sequencing of the polymorphic profiles found in SSCP allowed to translate the observed variability in variations of the nucleotide sequence. This investigation revealed the presence of a total of 4 nucleotide changes, described in Table 6. The changes occurring in the 3' untranslated region will be indicated by a * and numbered from the first nucleotide (* 1) following the translation stop codon (Dunnen et al., 2000).

Table 6. Sequence variants at *BMPR 1B* locus in Tunisian sheep. Reference sequence AF357007

BMPR 1B	nt variation
Exon 10	g. 87C>A
Exon 10 3'UTR	g. *132A>C
	g. *133T>A
	g. *168G>A

The nucleotide change that we found at position 87 of the 10th exon (A), can be also found in the bovine sequence, while the reference sheep sequence (Acc. No. AF357007) shows a (C). This nucleotide change occurs on the third base of the codon, and corresponds to a silent mutation: ACC→Thr, ACA→Thr. Being it

equal to the bovine sequence, then it may be considered phylogenetically more ancient than the reference sequence.

Based on SSCP analysis and based on the sequencing results, allele and genotype frequencies of the nucleotide changes occurring in the 3' UTR region of the 204 sampled sheep were assessed (Table 6 and 7).

Table 6. Genotype frequencies of mutations found at the 3'UTR region

Breed	Genotype frequencies								
	AA	AC	CC	AA	TA	TT	GG	GA	AA
Barbarine	84.6	10.3	5.1	2.6	12.8	84.6	100	-	-
Q. Fine Ouest	67.7	32.3	-	-	32.3	67.7	100	-	-
Noir de Thibar	91.2	8.8	-	-	8.8	91.2	100	-	-
Sicilo-Sarde	81.8	15.9	2.3	2.3	15.9	81.8	100	-	-
D'man	41.3	45.7	13.0	10.9	47.8	41.3	87.0	13.0	-
nt change	g. *132A>C			g. *133T>A			g. *168G>A		

Table 7. Allele frequencies of mutations found at the 3'UTR region

Breed	Allele frequencies					
	A	C	A	T	A	G
Barbarine	0.90	0.10	0.09	0.91	-	1
Q. Fine Ouest	0.84	0.16	0.16	0.84	-	1
Noir de Thibar	0.96	0.04	0.04	0.96	-	1
Sicilo-Sarde	0.90	0.10	0.10	0.90	-	1
D'man	0.64	0.36	0.35	0.65	0.07	0.93
nt change	g. *132A>C		g. *133T>A		g. *168G>A	

Analysis of Hardy Weinberg (HW) equilibrium revealed that the Barbarine breed was shown to be in disequilibrium ($P < 0.05$) for the g. *133T>A locus, while this breed respected the HW equilibrium for

all the others loci. The remaining four breeds were in HW equilibrium for all the analysed loci.

4. Final considerations

The absence of the currently known prolificacy genotypes in the Tunisian sheep breeds implies the possibility that these important mutations affecting prolificacy may be introduced in these breeds by genetic introgression. Indeed genetic introgression can be very beneficial because it allows the introduction of a genotype selectively advantageous in a breed already adapted to the environment in which it is reared (Gootwine et al., 2008; Hua and Yang, 2009). Two examples among many, the *FecB* mutation has been introgressed from Garole sheep into Deccani and Bannur sheep, improving the reproductive performance of local non prolific breeds (Pardeshi et al., 2005) and the crossbreeding of Garole x Malpura allowed the introgression of the *FecB* genotype carried by Garole sheep into the non prolific Malpura, improving the mean litter size of the crossbreds (Kumar et al., 2006). It has been evidenced that the simultaneous presence of the mutated genotypes at *BMPR 1B* gene and *BMP15* (in

heterozygosis) may have a multiplicative effect on ovulation rate, higher than that exerted by each single mutation (Davis, 2004).

The choice of the mutation to be used will depend on the breeding scheme. The mutations at *BMP15* and *GDF9* genes require more complex breeding schemes, because both carrier rams and non-carrier ewes need to be maintained in a crossbreeding system (Van der Werf, 2007). The incorporation of a major gene for prolificacy into a flock can be achieved using marker assisted selection, artificial insemination and embryo transfer programmes, and the source of these mutations may be progeny tested or DNA tested rams of different breeds carrying major genes for prolificacy (Davis et al., 2005).

All these information can be utilised for the improvement of Tunisian sheep breeding, to be applied in those areas of the country where environmental conditions allow to take advantage from the improvement of prolificacy.

5. Conclusions

Conclusions

The current study was designed to detect single nucleotide polymorphism within *BMPR1B*, *BMP15* and *GDF9* genes. Five sheep breeds, Brabarine, Queue Fine de L'Ouest, Noir de Thibar, Sicilo-Sarde and D'man, were used in this study.

The result showed that the prolificacy genotypes at genes *BMPR 1B*, *BMP15* and *GDF9* found so far in the genomes of many prolific breeds throughout the world, were absent in the five sheep breeds reared in Tunisia we examined.

A non functional mutation (B3) was found at *BMP15* gene, in Noir de Thibar sheep, derived by the crossbreeding between Queue Fine de L'Ouest x Merino de la Crau, this mutation has been first detected in sheep of British origin.

A new *BMP15* genotype (labelled B5) was detected in the Brabarine breed, which causes aminoacid change in the putative mature peptide, but further studies are necessary to understand its effects.

The highly prolific D'man ewes were monomorphic for the absence of all the known prolificacy alleles. The D'man sheep is reported to show high variation of ovulation rate (Lahlou-Kassi and Marie, 1985), this leads to hypothesize that a segregating major gene

affecting prolificacy exists in this breed, and it should be different from the ones detected up to now in prolific sheep breeds.

Analysis of a segment of the proximal promoter region of the *BMPR 1B* gene has shown that this region is highly conserved in sheep. In fact, there were no changes in the sequence of the five breeds studied.

In contrast, the 3'UTR region of the *BMPR 1B* gene has been shown to be highly variable, in fact, four SNPs were identified in the short segment examined, one of which was present only in the D'man breed.

6. References

1. **Arnaud** F., Caporale M., Varela M., Biek R., Chessa B., Alberti A., Golder M., Mura M., Zhang Y.P., Yu L., Pereira F., De Martini J.C., Leymaster K., Spencer T.E., Palmarini M. (2007). A Paradigm for Virus-Host coevolution: Sequential counter-adaptations between endogenous and exogenous retrovirus. *Plos Pathogens*, 3: 170.

2. Bittante, G., Andrighetto, I., Ramanzin, M. 2005. *Tecniche di produzione animale*. De Agostini Scuola SpA, Novara.

3. **Barker**, G. (2002). In: *Examining the Farming/Language Dispersal Hypothesis*, Bellwood P., Renfrew C. pp. 151-162. Eds. McDonald Institute Monographs, Cambridge.

4. **Barzegari**, A., Atashpaz, S., Ghabili, K., Nemati, Z., Rustaci, M., and Azarbaijani, R. (2009). Polimorphisms in *GDF9* and *BMP15* associated with fertilità and ovulation rate in Moghani and Ghezel sheep in Iran. *Reprod. Domest. Anim*, 10: 1439-0531.

5. **Bedhiac-Romdhani**, S., Djemali, M., Bello, A.A. (2008). Inventaires des différents ecotypes de la race Barbarine en Tunisie. *Agri*, 43: 41-47.

6. **Bindon**, B. (1984). Reproductive biology of the Booroola Merino sheep. *Aust. J. Biol. Sci*, 37: 163-189.

7. **Bodensteiner** K.J., Clay, C.M., Moeller, C.L., and Sawyer, H.R. (1999). Molecular cloning of the ovine growth differentiation factor 9 gene and expression of growth differentiation factor 9 in ovine and bovine ovaries. *Biol. Reprod*, 60 (2): 381-386.

8. **Bodin** L., Di Pasquale E., Fabre S., Bontoux M., Monget P., Persani L., Mulsant P. (2007). A novel mutation in the Bone Morphogenetic Protein 15 gene causing defective protein secretion is associated with both increased ovulation rate and sterility in Lacaune sheep. *Endocrinology*, 148 (1): 393-400.

9. **Bodin, L., Lecerf, F., Pisselet, C., San Cristhal, M., Bibe, M., and Mulsant, P. (2003).** How many mutations are associated with increased ovulation rate and litter size in progeny of Lacaune meat sheep. In: Proceedings of the International Workshop on Major Genes and QTL in sheep and Goat 2-11. Publisher INRA, Toulouse, France.
10. **Braw-Tal, R., McNatty, K.P., Smith, P., Heath, D.A., Hudson, N.L., Philips, D.J., McLeod, B.J., and Davis, G.H. (1993).** Ovaries of ewes homozygous for the X-linked Invedale gene ($FecX^1$) are devoid of secondary and tertiary follicles but contain many abnormal structures. *Biology of Reproduction*, 49: 895-907.
11. **Bunch, T.D., Wu, C., Zhang, Y.P., and Wang, S. (2006).** Phylogenetic analysis of snow sheep (*ovis nivicola*) and closely related taxa. *J. Hered.*, 79: 21-30.
12. **Campbell, B.K., Baird, D.T., Souza, C.J.H., and Webb, R. (2003).** The Fec^B (Booroola) gene acts at the ovary: in vivo evidence. *Reproduction*, 126: 101-111.

13. **Campbell**, B.K., Souza, C.J.H., Skinner, A.J., Webb, R., and Baird, D.T. (2007). Enhanced response of granulosa and theca cells from sheep carriers of the FecB mutation in vitro to gonadotropins and bone morphogenetic protein-2, -4, and -6. *Endocrinology*, 147: 1608-1620.

14. **Chang**, H., Brown, C.W., and Matzuk, M.M. (2002). Genetic analysis of the mammalian transforming growth factor- β superfamily. *Endocr. Rev*, 23: 787-823.

15. **Chen**, D., Zhao, M., and Mundy, G.R. (2004). Bone Morphogenetic proteins. *Growth Factors*, 22(4): 233-41.

16. **Chessa** B., Periera F., Arnaud F., Amorim A., Goyache F., Mainland I., Kao R.R., Pemberton J., M., Beraldi D., Stear M.J., Alberti A., Pittau M., Lannuzzi L., Banabazi M.H., Kazwala R.R., Zhang Y.P., Arranz J.J., Ali Bahy, A., Wang Z., Uzun M., Dione M.M., Olsaker I., Holm L.E., Saarma U., Ahmad S., Marzanov N., Eythorsdottir E., Holland M.J., Ajmone-Marsan P., Burford M.W., Kantanen J., Spencer

T.E., and Palmarini M. (2009). Revealing the history of sheep domestication using retrovirus integrations. *Science*, 324: 532.

17. Chu, M.X., Li, B.X., Wang, J.Y., Ye, S.C., and Fang, L. (2004). Association between PCR-SSCP of growth differentiation factor 9 Gene and high prolificacy in Small Tail Han Sheep. *Animal Biotechnology*, 15: 111-120.

18. Chu, M.X., Liu, Z.H., Jiao, C.L., He, Y.Q., Fang, L., Ye, S.C., Chen, G.H., and Wang, J.Y. (2007). Mutations in *BMPR-IB* and *BMP15* genes are associated with litter size in Small Tailed Han Sheep (*Ovis aries*). *J. Anim. Sci*, 85: 598-603.

19. Chu, M.X., Sang, L.H., Fang, L., and Ye, S.C. (2005). Study on *BMP15* and *GDF9* as candidate genes of prolificacy of Small Tail Han sheep. *Yi Chuan Xue Bao*, 32: 38-45.

20. Colledge, S., Conolly, J, and Shennan, S. (2005). *J. Archaeol*, 8: 137.

21. **Cunningham, J.** 2002. Textbook of veterinary physiology. Saunders Company, Philadelphia, U.S.A.

22. **Darfaoui, E.M.,** 1999. D'man sheep breeding programme in Morocco. In: Galal, S., Boyazoglu, J., Hammond, K. (Eds.), Proceedings of the Workshop on Developing Breeding Strategies for Lower Input Animal Production Environments, Bella, Italy, 22–25 September 1999, ICAR Technical Series 3, pp. 319–330.

23. **Davis G.H.** (2004). Major genes affecting ovulation rate in the sheep. *Genet. Sel. Evol*, 37: S11-S23.

24. **Davis G.H., Dodds K.G., Wheeler R. and Jay N.P.** (2001). Evidence that an imprinted gene on the X chromosome increases ovulation rate in sheep. *Biology of Reproduction*, 64: 216-221.

25. **Davis G.H., Galloway S.M., Ross I.K., Gregan Scott M., Ward J., Bon N., Pradip G.M., Nimbkar C., Gray D.,**

Subandriyo G., Inounu I., Tiesnamurti B., Martyniuk E., Eythordottir E., Mulsant P., Lecerf F., Hanrahan J.P., Bradford E.G., and Wilson T. (2002). DNA Test in Prolific Sheep from Eight Countries Provide New Evidence on Origin of the Booroola (FecB) Mutation. *Biology of Reproduction*, 66: 1869-1874.

26. Davis, G.H., Balakrishnan, L., Ross, I.K., Wilson, T., Galloway, S.M., Lumsden, B.M., Hanrahan, J.P., Mullen, M., Mao, X.Z., Wang, G.L., Zhao, Z.S., Zeng, Y.Q., Robinson, J.J., Mavrogenis, A.P., Papachristoforou, C., Peter, C., Baumung, R., Cardyn, P., Boujenane, I., Cockett, N.E., Eythorsdottir, E., Arranz, J.J. and Notter, D.R. (2006). Investigation of the Booroola (FecB) and Inverdale (FecX¹) mutations in 21 prolific breeds and strains of sheep sampled in 13 countries. *Animal Reproduction Science*, 92: 87-96.

27. Davis, G.H., Galloway, S.M., Ross, I.K., Gregan, S., Ward, J., Nimbkar, B.V., Ghalsasi, P.M., Nimbkar, C., Gray, G.D., Subandriyo, D.R., Inounu, I., Tiesnamurti, B., Martyniuk, E., Eythorsdottir, E., Mulsant, P., Lecerf, F.,

Bradford, G.E., Hanrahan, S.P., and Wilson, T. (2002). DNA tests for the Booroola (FecB) and Inverdale (FecX¹) mutations in eight breeds of sheep carrying putative major genes for prolificacy. *Biol. Reprod*, 66: 1869-1874.

28. De Rensis, F. 2001. *Fisiologia degli animali domestici*. Cristiano Giraldi Editore.

29. Driancourt, M.A., Cahill, L.P. and Bindon, B.M. (1985). Ovarian follicular populations and preovulatory enlargement in Booroola and control Merino ewes. *Journal of Reproduction and Fertility*, 73: 93-107.

30. Elvin, J.A., Yan, C., and Malsuk, M.M. (2000). Oocytes-expressed TGF-beta superfamily members in female fertility. *Mol. Cell. Endocrinol*, 159: 1-5.

31. Fabre S., Pierre A., Mulsant P., Bodin L., Di Pasquale E., Persani L., Monget P., and Monniaux D. (2006). Regulation of ovulation rate in mammals: contribution of

sheep genetics models. *Reproductive Biology and Endocrinology*, 4: 20.

32. FAO, (2007). Tunisie: rapport national sur les ressources génétiques animales. In: *The state of the World's animal genetic resources for food and agriculture*, edited by Barbara Rischkowsky & Dafydd Pilling, Rome.

33. Feary E., S., Juengel J.L., Smith P., French M.C., O'Connell A.R., Lawrence S.B., Galloway S.M., Davis G.H., and McNatty K.P. (2007). Patterns of expression of messenger RNAs encoding GDF9, BMP15, TGFBR1, BMPR1B and BMPR2 during follicular development and characterization of ovarian follicular populations in ewes carrying the Woodlands FecX2^W mutation. *Biology of Reproduction*, 77: 990-998.

34. Fogarty, N.M. (2009). A review of the effects of the Booroola gene (FecB) on sheep production. *Small Rum. Res.*, 85: 75-84.

- 35. Galloway, S.M, McNatty, K.P, Cambridge, L.M, Laitinen, M.P.E, Juengel, J.L, Jokiranta, S., McLaren, R.J., Luiro, K., Dodds, K.G., Montgomery, G.W., Beattie, A.E., Davis, G.H., and Ritvos, O. (2000). Mutations in an oocyte-derived growth factor gene (BMP15) cause increased ovulation rate and infertility in a dosage-sensitive manner. Nat. Genet, 25: 279-283.**
- 36. Galloway, S.M., Cambridge, L.M., Henry, H.M., van Stijin, T. C., and Davis, G.H. (1999). A genetic test to identify carriers of the ovine Inverdale fecundity gene. Proc. N. Soc. Anim. Prod., 59: 114-116.**
- 37. Galloway, S.M., Gregan, S.M., Wilson, T., McNatty, K.P., Juengel, J.L., Ritvos, O., and Davis, G.H. (2002). Bmp15 mutations and ovarian function. Molecular and Cellular Endocrinology, 191: 15-18.**
- 38. Gentry, A., Clutton-Brock and Groves, C. (2004). The naming of wild animal species and their domestic derivatives. J. Archaeol. Sci, 31: 645-651.**

39. Gilboa, L., Notte, E., Geissendorfer, T., Sebald, W., Henis, Y.L. and Knaus, P. (2000). Bone morphoetic protein receptor complexes on the surface of live cells: a new oligomerization mode for serine threonine kinase receptors. *Mol. Biol. Cell*, 11: 1023-35.

40. Gonzalez-Bulnes A, Souza C.J.H., Campbell B.K. and Baird DT. (2007). Effect of ageing on hormone secretion and follicular dynamics in sheep with and without the Booroola gene. *Endocrinology* 145 (6): 2858-2864.

41. Gootwine E., Reicher S. and Rozov A. (2008). Prolificacy and lamb survival at birth in Awassi and Assaf sheep carrying the FecB (Booroola) mutation. *Animal Reproduction Science*, 108: 402-411.

42. Guan F., Liu S.R., Shi G.Q. and Yang L.G. (2007). Polymorphism of FecB in nine sheep breeds or strain and its effects on litter size, lamb growth and development. *Animal Reproduction Science*, 99: 44-52.

43. Guedard, I., Chen, Y.G., Thevenet, I., Racine, C., Borie, S., Larnarre, I., Josso, N., Massague, J. and Di Clemente, N. (2000). Engagement of bone morphogenetic protein type IB receptor and Smad I signaling by anti-Muellerian hormone and its type II receptor. *J. Biol. Chem*, 275 (27): 973-8.

44. Hafez, E.S.E. (1984). *Reproduction in farm animals*. Lea & Febiger, Pennsylvania, U.S.A.

45. Hanrahan J.P., Gregan S.M., Mulsant P., Mullen M., Davis G.H., Powell R., and Galloway S.M. (2004). Mutations in the genes for oocytes-derived growth factors GDF9 and BMP15 are associated with both increased ovulation rate and sterility in Cambridge and Belclare sheep (*Ovis aries*). *Biology of Reproduction*, 70: 900-909.

46. Harris, D.R., and Gosden C. (1996). The origins and spread in agricultural and pastoralism in Eurasia. pp. 370-389. Harris D. Ed. (UCL Press, London).

- 47. Henderson, K.M., McNatty, K.P., O’Keeffe, L.E., Lun, S., Heath, D.A., and Prisk, M. (1987).** Differences in gonadotrophin stimulated cyclic AMP production by granulosa cells from Booroola x Merino ewes which were homozygous, heterozygous or non-carriers of a fecundity gene influencing their ovulation rate. *J. Reprod. Fertil*, 81: 395-402.
- 48. Hiendleder S., Lewaslski H., Wassmuth R. and Janke A. (1998).** The complete Mitochondrial DNA sequence of the domestic sheep (*Ovis aries*) and comparison with the other major ovine haplotype. *J. Mol. Evol*, 47: 441-448.
- 49. Hiendleder, S., Mainz, K., Plante, Y., and Lewaslski, H. (1998).** Analysis of mitochondrial DNA indicates that domestic sheep are derived from two different ancestral maternal sources: No evidence for contributions from Urial and Argali sheep. *Journal of Heredity*, 89: 113-120.
- 50. Hua G.H., Chen S.L., Ai J.T. and Yang L.G. (2008).** None of polymorphism of ovine fecundity major genes FecB

and FecX was tested in goat. *Animal Reproduction Science*, 108: 279-286.

51. Juengel J.L., Bibby A.H., Reader K.L., Stan L., Quirke L.D., Haydon L.J., McNatty K.P. (2004). The role of transforming growth factor-beta (TGF-beta) during ovarian follicular development in sheep. *Reproductive Biology and Endocrinology*, 2: 78.

52. Juengel, J.L., Bodensteiner, K.L., Heath, D.A., Hudson, N.L., Moeller, C.L., Smith, P., Galloway, S.M., Davis, G.H., Sawyer, H.R., and McNatty, K.P. (2004). Physiology of GDF9 and BMP15 signalling molecules. *Animal Reproduction Science*, 82-83: 447-460.

53. Juengel, J.L., Hudson, N.L., Heath, D.A., Smith, P., Reader, K.L., Lawrence, S.B., O'Connell, A.R., Laitinen, M.P., Granfield, M., Groome, N.P., Ritvos, O. and McNatty, K.P. (2002). Growth differentiation factor 9 and bone

morphogenetic protein 15 are essential for ovarian follicular development in sheep. *Biol. Reprod*, 67: 1777-1789.

54. Kareta, W., Korman, K. and Cegla, M. (2006). Ovulation level and prolificacy in ewes depending on their age, birth type and percentage of prolific genotype. *Reprod. Biol*, 6, suppl 2: 73-8.

55. Khaldi, G. (1989). Barbary sheep. *Small Ruminants in the Near East, vol; III, North Africa, FAO Anim. Prod. Heal. Paper*, 74: 96-135.

56. Knight P.G., and Glister C. (2006). Focus on TGF- β Signalling: TGF- β superfamily members and ovarian follicle development. *Reproduction*, 132: 191-206.

57. Knight, P.G., and Glister, C. (2001). Potential local regulatory functions of inhibins, activins and follistatin in the ovary. *Reproduction*, 121: 503-512.

- 58. Kumar, S., Kolte, A.P., Mishra, A.K., Arora, A.L, and Singh, V.K. (2006).** Identification of the Fec B mutation in garole X Malpure sheep and its effect on litter size. *Small Ruminant Research*, 64: 305-310.
- 59. Kumar, S., Mishra, A.K., Kolte, A.P., Arora, A.L. and Singh, D. (2008).** Effects of the Booroola (FecB) genotypes on growth performance, ewe's productivity efficiency and litter size in Garole x Malpure sheep. *Animal Reproduction Science*, 105: 319-331.
- 60. Lahlou-Kassi, A., Benlamlih, S., Boukkliq, R., Tibary, A., and Boujenane, I. (1988).** Reproduction and adaptation characteristics in D'man Sheep. *Journal of Agricultural Science in Finland*, 60: 566-575.
- 61. Land, R.B. (1970).** Number of oocytes present at birth in the ovaries of pure and Finish Landrace cross blackface and welsh sheep. *J. Reprod Fertil*, 21: 517-21

- 62. Lecferf, F., Foggia, L., Mulsant, P., Bonnet, A., and Hately, F. (2001).** A novel method to isolate the common fraction of two DNA samples: hybrid specific amplification (HSA). *Nucleic Acids Research*, 29: 87.
- 63. Lin, S.Y., Morrison, J.R, Philips, D.J, and de Krester, D.M. (2003).** Regulation of ovarian function by the TGF- β superfamily and follistatin. *Reproduction*, 126: 133-148.
- 64. Liu, S.F, Yan, Y.C, and Du, L.X. (2003).** Advances on localization and molecular mechanism of FecB gene. *Yi Chuan*, 25: 93-96.
- 65. Luikart, G., Fernandez, H., Marshkour, M, England, P.R, and Taberlet, P. (2006).** Origin and diffusion of domestic goats inferred from DNA markers: example analyses of mtDNA, Y chromosomes and microsatellites, documenting domestication. pp. 294-305. In: Zeder, M.A, Bradley, D.G, Emshwiler, E., Smith, B.D. (Eds), *New Genetic and Archaeological Paradigms*. University of California Press.

- 66. Maddox, J.F and Cockett, N.E. (2007).** An update on sheep and goat linkage maps and other genomic resources. *Small Ruminant Research*, 70: 4-20.
- 67. Martinez-Royo, A., Jurado, J.J., Snulders, J.P., Marti, J.I., Alabart, J.L., Roche, A., Fantova, E., Bodin, L., Mulsant, P., Serrano, M., Folch, F., and Calvo, J.H. (2008).** A deletion in the Bone Morphogenetic protein 15 gene causes sterility and increased prolificacy in Rasa Aragonesa sheep. *Animal Genetics*, 9: 294-27.
- 68. McNatty K.P., Galloway S.M., Wilson T., Smith P., Hudson N.L., O'Connell A., Bibby A.H., Heath D.A., Davis G.H., Hanrahan J.P., and Juengel J.L. (2005).** Physiological effects of major genes affecting ovulation rate in sheep. *Genet. Sel. Evol*, 37: S25-S38.
- 69. McNatty, K.P., Juerguel, J.L., Wilson, T., Galloway, S.M., and Davis, G.H. (2001).** Genetic mutations influencing ovulation rate in sheep. *Repro. Fertil. Dev.*, 13: 549-555.

- 70. McNatty, K.P., Smith, P., Moore, L.G., Reader, K., Lun, S., Hanrahan, J.P., Groome, N.P., Laitinen, M., Ritvos, O., Juengel, J.L. (2005).** Oocyte-expressed genes affecting ovulation rate. *Molecular and Cellular Endocrinology*, 234: 57-66.
- 71. Monniaux, D., Mandon-Pepin, B., and Monget, P. (1999).** L'atrésie folliculaire, un gaspillage programmé. *Médecine Sciences*, 15: 157-166.
- 72. Monteagudo, L.V., Ponz, R., Tejedor, M.T., Laviña, A., Sierra, I., (2009).** A 17 bp deletion in the Bone Morphogenetic Protein 15 (BMP15) gene is associated to increased prolificacy in the Rasa Aragonesa sheep breed. *Anim. Reprod. Sci.* 110, 139–146.
- 73. Montgomery G.W., Lord E.A., Penty J.M., Dodds K.G., Broad T.E., Cambridge L., Sunden S.L.F., Stone R.T. and Crawford A.M. (2002).** The Booroola fecundity (FecB) gene maps to sheep chromosome 6. *Genomics*, 22: 148-153.

- 74. Moore, R.K and Shimasaki, S. (2003).** Molecular biology and physiological role of the oocyte factor, BMP15. *Mol. Cell. Endocrinol*, 234: 67-73.
- 75. Moore, R.K., Erickson G.F. and Shimasaki S. (2004).** Are BMP-15 and GDF-9 primary determinants of ovulation quota in mammals. *Trends in Endocrinology and Metabolism*, 15, 8.
- 76. Mulsant P., Lecerf F., Fabre S., Schibler L., Monget P., Lanneluc I., Pisselet C., Riquet J., Monniaux D., Callebaut I., Crihiu E., Thimonier J., Teyssier J., Bodin L., Cognié Y., Chitour N., and Elsen J.M. (2001).** Mutation in bone morphogenetic protein receptor-IB is associated with increased ovulation rate in Booroola Mérimos ewes. *PNAS*, 98: 5104-5109.
- 77. Mulsant, P., Lecerf L., Fabre S., Bodin L., Thimonier J., Monget P., Lanneluc I., Monniaux D., Teyssier J., Elsen, J.M. (2003).** Prolificacy genes in sheep: the French genetic programmes. *Reprod. Suppl*, 61: 353-9.

- 78. Nadler, C., Lay, D.M., and Hassinger, J.D. (1971).** Cytogenetic analyses of wild sheep populations in northern Iran. *Cytogenetics*, 10: 137-152.
- 79. Nilson, E.E, Skinner, M.K. (2002).** Growth and differentiation factor 9 stimulate progression of early primary but not primordial rat ovarian development. *Biol. Reprod*, 67 (3): 1018-1024.
- 80. Notter, D.R. (2000).** Effects of ewe age and season of lambing on prolificacy in US Targhee, Suffolk, and Polypay sheep. *Small Rum. Res.*, 38: 1-7.
- 81. Notter, D.R. (2008).** Genetic aspects of reproduction in sheep. *Reprod. Dom. Anim*, 43: 122-128.
- 82. Otsuka, F., Yao, Z., Lee, T., Yamamoto, S., Erickson, G.F. and Shimasaki, S. (2000).** Bone morphogenetic protein-15: identification of target cells and biological functions. *J. Biol. Chem*, 275 (39): 523-528.

- 83. Pardeshi, V.C., Sainani, M.N., Maddox, J.F., Ghalsasi, P.M., Nimbkar, C., and Gupta, V.S. (2005).** Assessing the role of *FecB* mutation in productivity of Indian sheep. *Current Science*, 89: 887-890.
- 84. Pierre A., Fabre S., Mulsant P., Elsen J.M., Pisselet C., Monniaux D., and Monget P. (2002).** Ces bone morphogenetic proteins qui régulent le quota ovulatoire. *Nouvelles Magasine*, 18 : 1195-1196.
- 85. Pierre A. (2004).** Les Bone Morphogenetic Proteins dans l'ovaire. Contribution à l'étude de leurs mécanismes d'action dans les cellules de la granulosa. Thèse pour obtenir le grade de Docteur de l'Université de Tour. INRA.
- 86. Piper, L.R. and Bindon, B.M. (1982).** The Booroola Merino and the performance of medium non-Peppin crosses at Armidale. In the Booroola Merino, pp 9-20. Eds LR Piper, BM Bindon, RD Nethery. Melbourne: Ed. CSIRO.
- 87. Price, T.D. (2000).** Europe's first farmers. Cambridge Univ. Press, Cambridge.

88. Rekik, M., Ben Salem, I., Ben Hamouda, M., Diallo, H., Ammar, H., and Aloulou, R. (2005). Productivité numérique et pondérale des brebis produites du croisement entre la D'man et la race locale Queue fine de l'Ouest. *Revue Elev. Méd. Vét . Pays trop*, 58 (1-2) : 81-88.

89. Rekik, M., Lassoued, N., and Yacoubi, C. (2002). Reproductive performances in ewe lambs of the Queue Fine de l'Ouest and their D'man crosses following synchronisation. *Small Rum. Res.*, 45: 75-78.

90. Ricordeau, G., Thimonier, J., Polvey, I.P., Driancourt, M.A., Hochereau-de-Reviers, M.T., and Tchamitchian, L.: INRA. Research on the Romanov sheep breed in France: a review. *Livest. Prod. Sci*, 24: 305-332.

91. Ryder, M.L. (1984). Sheep. pp. 63-85. In: *Evolution of domesticated animals* (Mason SL, ed). London: Longman.

92. Sadighi, M., Bodensteiner, K.J, Beattie, A.E, and Galloway, S.M. (2002). Genetic mapping of ovine growth differentiation factor 9 (GDF9) to sheep chromosome 5. *Animal Genetics*, 33: 224-248.

93. Scherf, B.D. (2000). World Watch List for Domestic Animal Diversity, 3. FAO, 58.

94. Smith, P., Hudson, N.L., Corrigan, K.A, Shaw, L., Smith, T. Philips, D.J., and McNatty, K.P. (1996). Effects of Booroola gene (FecB^B) on body mass, testis development and hormone concentrations during fetal life. *J. Reprod. Fertil*, 108; 253-261.

95. Souza, C.J.H., Campbell, B.K., McNeilly, A.S., and Baird, D.T. (2003). Bone morphogenetic proteins and folliculogenesis: lessons from the Booroola mutation. *Reproduction Supplement*, 61: 361-370.

- 96. Souza, C.J.L., MacDougall, C., Campbell, B.K., McNeilly, A.S., and Baird, D.T. (2001).** The Booroola (FecB) phenotype is associated with a mutation in the bone morphogenetic receptor type 1 B (BMPR1B) gene. *Journal of Endocrinology*, 169: R1-R6.
- 97. Tapio, M., Marzanov, N., Ozerov, M., Cinkulov, M., Gonzarenko, G., Kiselyova, T., Murawski, M., Viinalass, H. and Kantanen, J. (2006).** Sheep mitochondrial DNA variation in European, Caucasian and Central Asian areas. *Mol. Biol. Evol*, 23; 1776-1783.
- 98. Thimonier J. (2006).** Gène Booroola de prolificité chez les ovins. Du rêve à la réalité : 20 ans.
- 99. Turner H.N. (1982).** Origins of the CSIRO Booroola, in: Piper, L.R., Bindon, B.M., Nethery, R.D. (Eds), *The Booroola Merino, Proceeding of a Workshop, Armidale, 24-25 August 1980*, CSIRO, 1982, pp. 1-7.

100. Van der Werf, J.H.J., 2007. Marker assisted selection in sheep and goats. In: E.P. Guimaraes, J. Ruane, B.D. Scherf, A.R. Sonnino & J.D. Dargie (eds.), Marker-assisted selection: current status and future perspectives in crops, livestock, forestry and fish. FAO (Publisher), Rome, Italy, pp. 229-247.

101. Wilson T., Wu X.Y., Juengel J.L., Ross I.K, Lumsden J.M., Lord E.A., Dods K.G., Walling G.A., McEwan J.C., O'Connell A.R., McNatty K.P., and Montgomery G.W. (2001). Highly prolific Booroola sheep have a mutation in the intracellular kinase domain of Bone Morphogenetic Protein IB Receptor (Alk-6) that is expressed in both oocytes and granulosa cells. *Biology of Reproduction*, 64: 1225-1235.

102. Woronzow, N.M., Korobizgna, K.W., Nadler, C.F., Hofman, R., Esalojnitskow, T.N., and Gorelow, J.K. (1972). Chromossomi dikich baranow I proisschojdjenjedomaschnich owjez. *Lriroda* 3: 74-81.

103. Young J.M., Juengel J.L., Dodds K.G., Laird M., Dearden P.K., McNeilly A., McNatty K.P., and Wilson T. (2008). *Journal of Endocrinology*, 196: 251-261.

104. Zeder, M.A. (2008). *Proc. Natl. Acad. Sci. U. S. A.*, 105: 11597.

105. Zeuner, F.E. (1963). *A history of domesticated animals*. London: Hutchinson.

106. Zhu G., Guo B., Pan D., Mu Y. and Feng S. (2008). Expression of bone morphogenetic proteins and receptors in porcine cumulus-oocyte complexes during *in vitro* maturation. *Animal Reproduction Science*, 104: 275-283.