

Interference Alignment at Intermediate SNR with Perfect or Noisy CSI

FEDERICO MIATTON



KTH Electrical Engineering

Master's Degree Project
Stockholm, Sweden
May 2010

XR-EE-KT 2010:004

Abstract

Interference alignment is a new technique combining transmitter precoding and receiver interference suppression to achieve the optimal multiplexing gain in interference networks by exploiting knowledge of channel state information of all transmission links. So far closed form solutions for the transmit filters have only been found in certain cases. Also the feasibility of interference alignment schemes based on symbol extensions, over a limited number of signalling dimensions, is still an open problem.

In this work we investigate the performance in terms of bit error rates, of interference alignment schemes at intermediate signal-to-noise ratios, through Monte Carlo simulations. We focus our attention on the three and four users time-varying interference channel, using both the closed form solutions known at present as well as iterative algorithms. We then investigate the impact of noisy channel state information on the performances of some of the interference alignment systems considered.

In the single input single output interference channel the closed form solutions of the interference alignment cause considerably different bit error rates for the different nodes in the network. In the multiple input multiple output interference channel we exhibit that bit error rate saturates at moderate signal-to-noise ratios when interference alignment schemes are infeasible and even when they are feasible, some of the analyzed algorithms show unpredictable behaviors by deteriorating the performance as the signal-to-noise ratio exceeds a threshold. Further refinements are necessary in order to obtain better bit error rates in these cases. We evince that additional improvements are also needed to the original interference alignment schemes in order to mitigate their sensitivity to noisy channel state information.

Contents

Abstract	i
List of Tables	v
List of Figures	vi
List of Abbreviations	vii
1 Introduction	1
1.1 Motivation	3
1.2 Outline	3
2 Preliminaries	5
2.1 Interference Channels	5
2.2 CSIT and Transmit Precoding	6
2.3 Introduction to Interference Alignment	8
2.4 Channel Model	10
2.5 System Model	11
3 Interference Alignment	15
3.1 Interference Alignment	15
3.1.1 The alignment of interference	16
3.2 Interference Alignment for SISO Systems	19
3.2.1 Closed form original beamforming design	21
3.2.2 Closed form efficient beamforming design	24
3.2.3 On the optimality of IA for SISO systems	27

3.3	Interference Alignment for MIMO Systems	29
3.3.1	Closed form beamforming design for three users MIMO	29
3.3.2	Iterative Interference Alignment	31
3.4	Feasibility of IA	37
4	Interference Alignment with Noisy CSIT	39
4.1	CSIT	40
4.2	System Model	42
4.2.1	Perfect and Noisy CSIT	43
5	Simulation Results	45
5.1	System model and practical implementation	45
5.2	Numerical computation of the feasibility of IA schemes	48
5.3	Simulation results with perfect CSI	50
5.3.1	SISO-IC: three nodes single antenna with $n^* = 0$	51
5.3.2	MIMO-IC: three nodes with two antennas sending one stream	54
5.3.3	MIMO-IC: three nodes with four antennas sending two streams	56
5.3.4	MIMO-IC: four nodes with four or five antennas sending two streams	58
5.3.5	MIMO-IC: Performances of the <code>Max_SINR</code> algorithm	61
5.3.6	Performances of the closed form expressions of the beamforming matrices for the SISO-IC and MIMO-IC	62
5.4	Simulation results with noisy CSI	63
5.4.1	SISO-IC: three nodes single antenna with $n^* = 0$	63
5.4.2	MIMO-IC: three nodes with two antennas sending one stream	63
6	Conclusions and Future Work	65
	Bibliography	67

List of Tables

5.1	SISO-IC: three nodes single antenna with $n^* = 0$	51
5.2	MIMO-IC: three nodes with two antennas sending one stream. System parameters and explicit expressions of the beamforming matrices.	55
5.3	MIMO-IC: three nodes with four antennas sending two streams. System parameters and explicit expressions of the beamforming matrices.	56
5.4	MIMO-IC: four nodes with four antennas sending two streams. System parameters.	59
5.5	MIMO-IC: four nodes with five antennas sending two streams. System parameters.	59

List of Figures

2.1	System with transmit precoding.	6
2.2	CSIT obtained using the reciprocity principle.	7
2.3	CSIT obtained by feedback.	7
2.4	Interference network with $K = 3$ pairs of transmitter-receiver.	12
3.1	Perfect alignment at receiver i of the interference caused by transmitters j and k	17
4.1	Noisy $\tilde{\mathbf{V}}$ and $\tilde{\mathbf{U}}$ cause some interference remaining in the desired signal subspace.	42
5.1	The model implemented to carry out our simulations.	46
5.2	Percentage of interference in desired signal subspace in the three users and four users MIMO-IC.	49
5.3	SISO-IC: three nodes single antenna with $n^* = 0$	53
5.4	MIMO-IC: three nodes with two antennas sending one stream.	55
5.5	MIMO-IC: three nodes with four antennas sending two streams.	57
5.6	MIMO-IC: <code>Max_SINR</code> algorithm in a four nodes network.	60
5.7	MIMO-IC: performances of the <code>Max_SINR</code> algorithm.	61
5.8	SISO-IC and MIMO-IC: three user closed form expressions.	62
5.9	SISO-IC with Noisy CSI: three nodes single antenna with $n^* = 0$	64
5.10	MIMO-IC with Noisy CSI: three nodes with two antennas sending one stream, closed form solutions of IA.	64

List of Abbreviations

3GPP	Third Generation Partnership Project
AWGN	Additive White Gaussian Noise
BER	Bit Error Rate
BMAP	Bit Mapper
CSI	Channel State Information
CSIR	Channel State Information at the Receiver
CSIT	Channel State Information at the Transmitter
FDMA	Frequency Division Multiple Access
IA	Interference Alignment
IBMAP	Inverse Bit Mapper
IC	Interference Channel
LTE	Long Term Evolution
MIMO	Multiple Input Multiple Output
MIMO-IC	Multiple Input Multiple Output Interference Channel
ML	Maximal-Length
MMSE	Minimum Mean Square Error
OFDM	Orthogonal Frequency Division Multiplexing
PN	Pseudo-Noise
QPSK	Quadrature Phase Shift Keying
RVQ	Random Vector Quantization
SISO	Single Input Single Output
SISO-IC	Single Input Single Output Interference Channel
SINR	Signal-to-Interference-plus-Noise Ratio
SNR	Signal-to-Noise Ratio
SVD	Singular Value Decomposition
TDMA	Time Division Multiple Access
WLI	Weighted Leakage Interference

Introduction

Interference is one of the fundamental characteristics of wireless communication systems, in which multiple transmissions occur simultaneously over a common communication channel. Since interference is one of the limiting features of a wireless network, how to deal with it optimally is one of the most important aspects of communication in a multiuser scenario.

In most existing wireless communication systems interference is handled by coordinating the users to orthogonalize the channel access or by increasing the transmission power and treating the interference from other transmitters as noise. The first approach is the basis of time or frequency division medium access schemes while, in the second case, single user encoding/decoding usually suffices if interference is weak. When interference is strong, the decodability of the desired signals can be affected so that it might be necessary to resort multi-user detection techniques. In most of the cases, however, the complexity of such techniques prevents their applicability in practice [20].

In the last times research has focused on how to intelligently exploit

the knowledge of any characteristics of the channel (e.g. the realizations of the channel or only their statistics) in order to improve the reliability and the throughput of wireless communication systems, at both the receiver and the transmitter sides. Knowledge of the channel state at the transmitter side, particularly, permits to substantially improve the overall performances [23]. Since the presence of a feedback channel between the receiver and the transmitter is often a reasonable assumption, further research has also been accomplished in order to optimize and reduce the amount of feedback necessary to be fed back at the transmitter [29]. A large number of techniques using only partial or quantized channel information at the transmitter side have therefore been presented (e.g. [30]).

An overview of several approaches for handling interference in multicell multiple input multiple output (MIMO) systems is given in [24], while a summary of the last interference management techniques available for 4G orthogonal frequency division multiplexing (OFDM) systems with an emphasize on Long Term Evolution (LTE) can be found in [31]. For an overview of the LTE and LTE-Advanced standards we refer to [32], [33], [34].

While most of the work, both theoretical (e.g. in terms of capacity characterizations) and practical (e.g. in terms of transmit and receive techniques), since the introduction of multiple antennas in wireless communications refers to the MIMO multiple-access channel and the MIMO broadcast channel [20], more recently a new interest for the interference channel (IC) has come back.

The interference channel [1] is the mathematical model for a communication network where the transmission medium is shared by a number of pairs of transmitter and receiver, and each sender communicates information only to its receiver and generates interference to all the others. The capacity region of the interference channel is difficult to obtain and remains still unknown in general. In the last two years, however, the research has moved to the multiplexing gain characterization of interference networks and a new technique called interference alignment has been presented.

Interference alignment is basically a combination of linear precoding at

the transmitters and interference suppression at the receivers that permits to achieve the optimal multiplexing gain of interference networks. After the work presented in [2] a large number of publications on interference channels and interference alignment came to light [3]–[16].

1.1 Motivation

Interference alignment permits to achieve the optimal multiplexing gain of interference networks. At the present, the optimality of this scheme has been reported only for some specific cases and exact solutions on its achievability are yet unknown in general. Furthermore in some cases the optimality is guaranteed only in the high signal-to-noise (SNR) ratios regime.

The main insight of this work is to evaluate, through Monte Carlo simulations, the performances at intermediate SNR values of interference alignment schemes employing both the only exact form solutions of interference alignment known at the present, as well as some iterative algorithms present in literature. We also evaluate the impact of noisy channel state information (CSI) on the performances of some of the implemented systems.

At the time of starting of this work, all the works present in literature had characterized this new scheme only in terms of sum capacity, showing its optimality in the high SNR regime, and no other performance metrics had been given. This has motivated us to evaluate interference alignment in terms of bit error rates when perfect or noisy CSI are available.

1.2 Outline

This thesis is organized as follows. In Chapter 2 we present the technical background materials needed to understand the following. We assume however that the reader is familiar with some basic notions of linear algebra and matrix calculus. In Chapter 3 we discuss in detail the interference alignment

technique, giving the general expressions of the known closed form solutions at the present and exhibiting the iterative algorithms used in the simulations. Chapter 4 presents the general model of the noisy channel state information that we use through this work. Finally in Chapter 5 we explain the model used for our simulations specifying the general expressions introduced in the previous chapters and we discuss the results of our simulations. We conclude our work with some last remarks in Chapter 6.

Preliminaries

In this chapter we present the context in which this work takes place and furthermore we give the technical background needed to understand the following. We start providing a brief overview of interference channels and systems that employ transmitter precoding. We then introduce the interference alignment scheme, presenting the main characteristics of this technique. We conclude the chapter by presenting the channel model and the system model that have been used in this work.

2.1 Interference Channels

The interference channel is a mathematical model for a communication network where the transmission medium is shared by a number of pairs of transmitter and receiver. Each transmitter communicates information only to its desired receiver and subsequently generates interference to all the receivers. The interference channel has been defined for the first time in [1] and since then there has been a lot of research in order to establish the capacity limits

of interference networks. However the capacity region has been found only in special cases and it remains unknown in general. In a K user interference network a one-to-one correspondence exists between all the transmitters and the receivers so that there are K principal links and $K(K - 1)$ interfering links. An example of interference network is given by Figure 2.4.

When all the nodes in the network are equipped with only one antenna the interference channel is usually referred to as single input single output interference channel (SISO-IC). Similarly, we denote as multiple input multiple output interference channel (MIMO-IC) an interference network in which the nodes are equipped with multiple antennas. In the latter case, if the transmitters exploit the available multiple antennas to send independent data streams to their respective receivers, each of these streams will also undergo interference from the other streams of the same transmitter in addition to the interference caused by the other transmitters in the network.

2.2 CSIT and Transmit Precoding

The benefits of channel knowledge at the transmitter side are well established. When channel state information are available to the transmitter (CSIT) it is possible to adapt the transmitting signal to the channel conditions so that significant improvements of the performance are obtainable [23]. The broad class of processing techniques that permits to exploit the availability of channel state information at the transmitter, is referred to as transmit precoding or beamforming. The processing is performed just before transmitting the signal over the channel. A simple model for a system with transmit precoding is depicted in Figure 2.1.

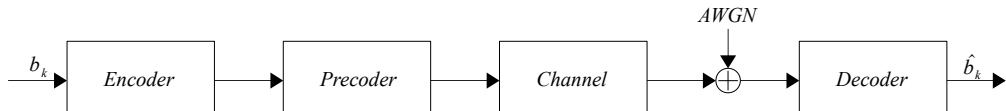

Figure 2.1: System with transmit precoding.

There are mainly two ways for obtaining CSIT: invoking the reciprocity principle for wireless communications or using a feedback channel from the receiver to the transmitter. The two methods are illustrated in Figure 2.2 and Figure 2.3.

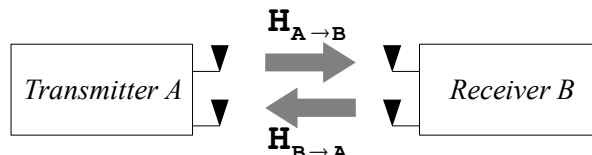

Figure 2.2: CSIT obtained using the reciprocity principle.

The reciprocity principle states that the transfer function of the channel between the transmitting antenna and the receiving antenna at time t is identical to the transpose of the channel between the receiving and the transmitting one at time t , provided that the two channels use the same frequency. This is not possible in real full duplex communication systems as the forward and the reverse channel cannot use the same frequency, time and spatial coordinates. Nevertheless the principle can still hold if the differences in any of those are sufficiently small compared to the channel variations in the same dimensions.

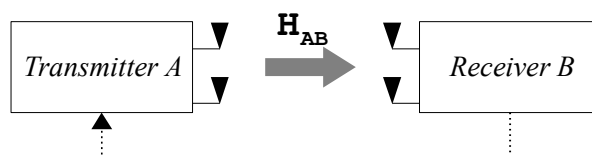

Figure 2.3: CSIT obtained by feedback.

Another way to obtain CSIT is using feedback. In this case the forward channel between the transmitter and the receiver is measured using, for instance, pilot symbols known at both sides and the estimate of the real channel is then sent back to the transmitter. Even if more attractive in practice, this method imposes additional use of transmission resources and complexity at both sides. Typical ways of communicating CSIT are piggybacking or using a dedicated feedback channel, which is often assumed to be limited by,

for example, some rate constraints. Techniques for reducing the amount of feedback to be transmitted have been extensively investigated and are still objectives of research [23], [25], [29], [30].

In general, in a system that employs transmit precoding, at the sender side the encoder is followed by the precoder which processes the information signal before sending it over the channel. Analogously, the receiver is equipped with a decoder which gives an estimate of the original signal. The cascade of precoder and channel acts as an effective channel and the receiving signal is therefore simply the output signal of the cascade corrupted by white Gaussian noise.

2.3 Introduction to Interference Alignment

Interference Alignment is a new scheme employing both linear precoding at the transmitters and interference suppression at the receivers that permits to achieve the optimal multiplexing gain of interference networks [2]. With some fundamental distinctions, interference alignment can be applied to both networks comprised of single antenna nodes and multiple antenna nodes.

We now recall some useful definitions. The capacity region $\mathcal{C}(\rho)$ of the K user interference channel is the set of all achievable rate vectors $\mathbf{R}(\rho) = (R_1(\rho), R_2(\rho), \dots, R_K(\rho))$ for which all the users at the same time can reliably communicate over the K principal links. Here, ρ indicates the signal to noise ratio, defined as the total power across all the transmitters when the power of the noise at each node is normalized to unity. The multiplexing gain r of an interference network is defined as [17], [20]:

$$r = \lim_{\rho \rightarrow \infty} \frac{C_\Sigma(\rho)}{\log(\rho)}, \quad (2.1)$$

where C_Σ is an achievable sum rate at signal to noise ratio ρ . The multiplexing gain is also denoted degrees of freedom or capacity pre-log factor of the network.

As we stated before, the capacity characterization of interference networks is unknown in general and very difficult to obtain. Despite this, a great deal of effort has recently permitted to characterize the optimal multiplexing gains of interference networks and to show how to achieve them with a new form of transmit beamforming called interference alignment [2]. The novelty brought by the paper is that, instead of analyzing directly the capacity region, the resource of interest being considered is the number of signalling dimensions that each user can utilize to communicate without interference. The total number of interference-free dimensions available for all the users thereby determines the capacity pre-log factor of the network.

In the specific case of the interference alignment scheme, the transmit precoding matrix processes d_i information streams in order to form the transmit signal to be sent over the wireless channel. We indicate with (d_1, d_2, \dots, d_K) the degrees of freedom distribution of the network or in other terms the number of independent information streams transmitted per channel use by transmitters $1, 2, \dots, K$. At the receiver, assuming that all the interference is aligned in the same subspace, in a sense that will be clear later, the elimination of the interference is possible simply multiplying the received signal by a zero-forcing interference suppression matrix.

To introduce the main features of the interference alignment scheme, consider a single pair of transmitter and receiver. Since there is no interference, communication using all available resources is possible. Let us say now that another pair of transmitter and receiver wants to communicate over the same medium. The most fair solution for each user is to communicate without interference using only half the available resources, for example for half the time or using half the available bandwidth. The question addressed is how this result can be extended to more than two users. The answer proposed by traditional orthogonal schemes like the time division multiple access (TDMA) or the frequency division multiple access (FDMA) is that, if interference is to be avoided in a medium shared between K users, each user has to get access to a fraction $1/K$ of the available resources.

The main contribution of [2] is to show that, regardless of the number of the users, everyone can communicate without interference using half of the available resources. Thus, with interference alignment, no more than half of the total degrees of freedom is lost because of the interference, either with single antenna nodes or with multiple antenna nodes. While the optimum is achieved exactly in certain schemes when nodes have multiple antenna nodes, the optimum is reached only asymptotically for high SNR for networks composed of single antenna nodes.

Note that there interference alignment schemes can be constructed in any dimensions such as time, either through propagation delays or coding across time varying channels, frequency, either through Doppler shifts or coding across different bands over frequency selective channels, and space, through beamforming over different antennas. In this work we will consider only interference alignment schemes constructed in signal space. Thus we will not deal with schemes where the alignment of interference is constructed in signal scale through, for instance, lattice codes [7].

2.4 Channel Model

The model for the wireless channel used throughout this work is the Rayleigh fading channel model [17]. In a multipath environment the received signal is given by a number of replicas of the transmitted signal, each of which reaches the receiver with a different delay and experiences a different attenuation and phase rotation due the differences in the path lengths and the reflections.

A discrete-time baseband channel model consists of a number of taps [17], [18]. The assumption at the basis of the Rayleigh fading model is that in a rich scattering environment the number of the reflected and scattered paths that contributes to each of the taps of the channel is large. In addition, it is reasonable to assume that the scatterers are located far away from the receiver and the distance travelled by the replicas are much larger than the wavelength corresponding to the frequency of the transmitted signal. There-

fore the phases of different paths are independent and each of the phases is uniformly distributed between 0 and 2π .

Since each tap is given by the sum of a large number of independent random variables, by the Central Limit Theorem both the real part and the imaginary part of all the taps are therefore Gaussian random variable and each tap is in turn a circularly symmetric complex random variable. The presence of a line-of-sight component will result in a nonzero channel mean and the channel envelope will have Rician statistics, while if no line-of-sight component is present the random variables will have zero mean and the channel envelope will have Rayleigh statistics. In order to avoid degenerate situations we will assume that the channel gains are bounded between a minimum nonzero value a maximum finite value.

Furthermore, in the MIMO scenarios considered in this work we assume also that the antennas are sufficiently spaced from each other to ensure decorrelation of the channel elements. This is generally true since in a rich scattering environment the antenna spacing required for decorrelation is typically $\lambda/2$ where λ is the wavelength of the transmitted signal [20].

For simplicity we also assume that the channel is flat-fading so that the channel is characterized by a single tap and the convolution operation reduces to a simple multiplication. This model, however, can be also applied in a frequency-selective environment by dividing the transmission band into multiple narrow bands so that the fading experienced within each of these subbands is still flat. In addition, due to changes in the surrounding environment the channel realizations will vary with time.

2.5 System Model

We consider a generic K user interference channel system where K transmitters are sending independent information streams to K receivers simultaneously so that, besides the desired signal, each receiver experiences interference

from $K(K - 1)$ transmitters. Figure 2.4 depicts an interference system with $K = 3$ couples of transmitters and receivers.

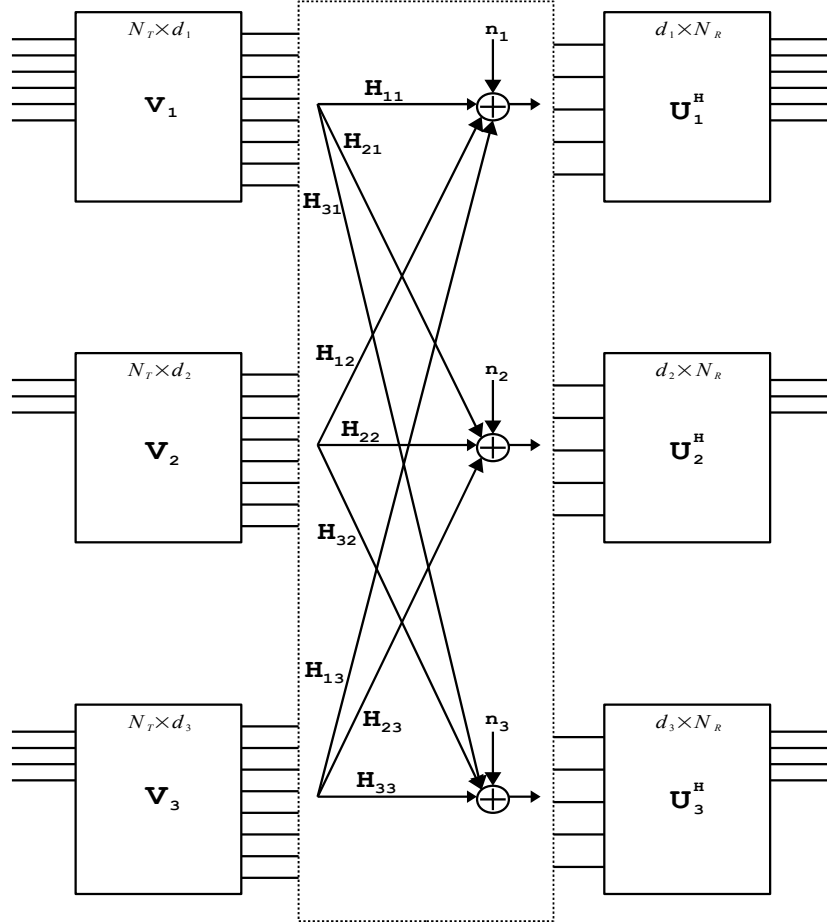

Figure 2.4: Interference network with $K = 3$ pairs of transmitter-receiver.

Each transmitter is equipped with N_T antennas and each receiver has N_R antennas. The channel between the transmitter j and the receiver i at time t is modeled by the $N_R \times N_T$ channel matrix $\mathbf{H}_{ij}(t)$. As we said before, we can construct interference alignment scheme in time or frequency dimensions, so the channel use index t can be used to describe equivalently one of these dimension.

However to clarify the exposition we consider here that the index t indicates the time and the channel coefficients are time-varying independent

complex Gaussian random variables with zero means and unit variances. In fact, in a rich scattering environment, a frequency-flat MIMO channel can be modelled as a time-varying matrix with complex Gaussian coefficients [17], [20]. A zero mean corresponds to a channel with Rayleigh statistics, while a nonzero channel mean takes into account a direct line-of-sight path and corresponds to the Rician statistics.

In this work we do not indicate explicitly the time index to avoid cumbersome notation.

We define with \mathbf{x}_i the $d_i \times 1$ information vector for the i th transmitter at time t , where d_i is the number of information streams transmitted per time slot by the transmitter in question. Note that it must be $d_i \leq N_T$.

Also, defining the $N_T \times d_i$ transmit beamforming matrix for transmitter i as \mathbf{V}_i , the transmit signal is then given by $\mathbf{s}_i = \mathbf{V}_i \mathbf{x}_i$. The columns of \mathbf{V}_i indicate the signaling vectors and represent the directions along which the data symbols are beamformed before being transmitted over the channel.

The signal power at transmitter i is given by $\mathbb{E}[\mathbf{s}_i^H \mathbf{s}_i] = P_i$ and since we assume that the transmit filter is normalized to unit power so that $\mathbb{E}[\mathbf{V}_i^H \mathbf{V}_i] = \mathbf{I}$ we can further write that $\mathbb{E}[\mathbf{s}_i^H \mathbf{s}_i] = \mathbb{E}[\mathbf{x}_i^H \mathbf{x}_i] = P_i$, where we indicate with P_i the available power at transmitter i .

The received signal vector at receiver i is hence given by

$$\mathbf{r}_i = \mathbf{H}_{ii} \mathbf{V}_i \mathbf{x}_i + \sum_{j=1, j \neq i}^K \mathbf{H}_{ij} \mathbf{V}_j \mathbf{x}_j + \mathbf{n}_i, \quad (2.2)$$

where the first term is the desired signal, the second summation comprises all the interference caused by the other transmitters and \mathbf{n}_i is the $N_R \times 1$ additive white Gaussian noise (AWGN) vector, modelled as an independent and identically distributed complex Gaussian vector with zero mean and covariance matrix $\mathbb{E}[\mathbf{n}_i^H \mathbf{n}_i] = \sigma_{n_i}^2 \mathbf{I}_{N_R}$, $\forall i \in \{1, 2, \dots, K\}$. For simplicity we assume that the noise power at each node is normalized to unit so that $\sigma_{n_i}^2 = 1$, $\forall i \in \{1, 2, \dots, K\}$ and the noise covariance matrix reduces to the identity matrix: $\mathbb{E}[\mathbf{n}_i^H \mathbf{n}_i] = \mathbf{I}_{N_R}$, $\forall i \in \{1, 2, \dots, K\}$.

We indicate the decoding $N_R \times d_i$ matrix, also called interference suppression matrix, for the receiver i as \mathbf{U}_i . We will later assert that the multiplication of the received signal by \mathbf{U}_i^H permits to suppress all the interference at receiver i and also decouples the d_i transmitted streams.

Finally, the $d_i \times 1$ signal vector after interference suppression can be expressed as

$$\mathbf{y}_i = \mathbf{U}_i^H \mathbf{H}_{ii} \mathbf{V}_i \mathbf{x}_i + \sum_{j=1, j \neq i}^K \mathbf{U}_i^H \mathbf{H}_{ij} \mathbf{V}_j \mathbf{x}_j + \mathbf{U}_i^H \mathbf{n}_i. \quad (2.3)$$

Assuming that at receiver i the interference from all the unintended transmitters is perfectly aligned, in a sense that will be clarified later, the multiplication by the interference suppression matrix eliminates all the interference so that the second term is nullified, and we can write

$$\mathbf{y}_i = \mathbf{U}_i^H \mathbf{H}_{ii} \mathbf{V}_i \mathbf{x}_i + \bar{\mathbf{n}}_i \quad (2.4)$$

where $\bar{\mathbf{n}}_i = \mathbf{U}_i^H \mathbf{n}_i$ is the effective noise after the suppression of interference. We also note that the cascade of beamforming matrix, channel and interference suppression matrix acts as an effective channel $\bar{\mathbf{H}}_{ii} = \mathbf{U}_i^H \mathbf{H}_{ii} \mathbf{V}_i$ and we can further write

$$\mathbf{y}_i = \bar{\mathbf{H}}_{ii} \mathbf{x}_i + \bar{\mathbf{n}}_i. \quad (2.5)$$

It is now possible to apply the zero-forcing channel equalizer to get a replica of the transmitted symbols corrupted by the Gaussian noise amplified by the interference suppression filter and the zero-forcing equalizer:

$$\hat{\mathbf{x}}_i = \mathbf{x}_i + \left[(\bar{\mathbf{H}}_{ii}^H \bar{\mathbf{H}}_{ii})^{-1} \bar{\mathbf{H}}_{ii}^H \right] \mathbf{U}_i^H \mathbf{n}_i, \quad (2.6)$$

where we have implicitly defined with $\mathbf{C}_i = (\bar{\mathbf{H}}_{ii}^H \bar{\mathbf{H}}_{ii})^{-1} \bar{\mathbf{H}}_{ii}^H$ the zero-forcing equalizer for the effective channel.

Interference Alignment

In this chapter we present in detail the interference alignment schemes that have been addressed in this thesis. We first introduce the main features of this scheme and some of difficulties connected with the alignment of the interference in a multi-user network. We then specify the general system model introduced previously in the two main cases studied here, networks composed of nodes equipped with one antenna and networks of multiple antenna nodes. Closed form solutions of the interference alignment problem are specified and for the case of multiple antenna nodes two iterative algorithms have also taken into account. We conclude the chapter with an analysis of the feasibility of interference alignment schemes.

3.1 Interference Alignment

As introduced before, recently the investigation on the interference channel has moved to the multiplexing gain characteristics of interference networks and new results have been achieved in terms of approximate capacity char-

acterizations. One of the main contributions has been given by [2], which establishes a new bound for the sum capacity of the K user interference channel with time or frequency varying channel coefficients and proves its achievability through a new technique called interference alignment.

The basic idea of interference alignment, abbreviated as IA, is to construct transmit signals in such a way that the interference caused at all the unintended receivers overlaps onto the same subspace while they still remain separable at the receivers where they are desired [2]. If this happens, interference suppression is possible simply by zero-forcing the interference at each receiver. Interference alignment is thus a combination of transmit precoding at the transmitters and interference suppression at the receivers, though the core of this method basically resides in the design of the transmit beamforming matrices.

3.1.1 The alignment of interference

The core of interference alignment schemes is the design of the beamforming matrices in such a way that, at each receiver in the network, the interference caused by all the unintended transmitters is aligned in the same subspace so that its elimination is possible by simply projecting the received signal onto the orthogonal complement of this subspace, which is accomplished through the multiplication by the interference suppression matrix.

To clarify this concept and introduce the problem, consider Figure 3.1 that shows the situation at receiver i , assuming that there are two other transmitters, j and k , present. Here we consider a MIMO scenario, with $N_T = N_R = 2$ and $d_i = d_j = d_k = 1$. The dimension of the receive signal space is equal to the number N_R of receiving antennas, two in this case.

Figure 3.1 depicts the perfect alignment of the interference at receiver i . In fact, the interference caused by transmitters j and k perfectly aligns in a one dimensional subspace and, indicated with $\text{span}(\mathbf{A})$ the column space of the matrix \mathbf{A} or rather the subspace spanned by the columns of \mathbf{A} , we write:

$$\text{span}(\mathbf{H}_{ij}\mathbf{V}_j) = \text{span}(\mathbf{H}_{ik}\mathbf{V}_k). \quad (3.1)$$

Therefore the suppression of all the interference is possible by projecting the received signal \mathbf{y}_i onto the orthogonal space of the interference. Denote the null space¹ of the matrix \mathbf{A} by $\text{null}(\mathbf{A})$, and assuming that (3.1) is satisfied, the interference suppression matrix for the receiver i is given by

$$\mathbf{U}_i = \text{null}([\mathbf{H}_{ij}\mathbf{V}_j]^H) = \text{null}([\mathbf{H}_{ik}\mathbf{V}_k]^H), \quad (3.2)$$

where the transpose operation is necessary since we are looking for the left null space of the interference that is the orthogonal complement of the column space. On the other hand the energy of the signal part that lays in the interference subspace is lost after the projection on \mathbf{U}_i^H .

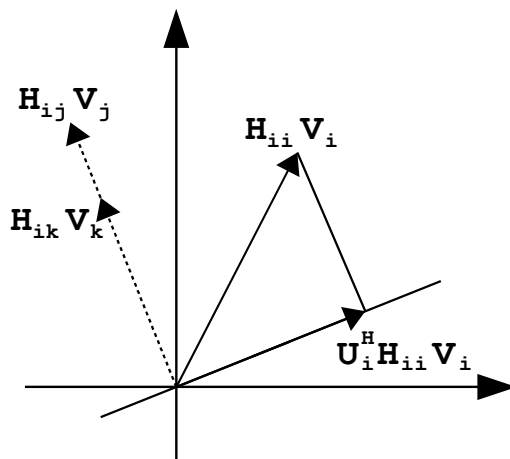

Figure 3.1: Perfect alignment at receiver i of the interference caused by transmitters j and k .

Consider now a generic K user interference channel. In order to understand the problem of interference alignment, we focus our attention on two particular transmitters, for instance 1 and 2, and two receivers where they cause interference, for instance 3 and 4. Interference alignment implies that,

¹The null space of an $m \times n$ matrix \mathbf{A} is the set of the solutions of the homogeneous equation $\mathbf{A}\mathbf{x} = \mathbf{0}$, i.e. $\text{null}(\mathbf{A}) = \{\mathbf{x} \in \mathbf{R}^n : \mathbf{A}\mathbf{x} = \mathbf{0}\}$

at receivers 3 and 4, the following constraints should be satisfied:

$$\text{span}(\mathbf{H}_{31}\mathbf{V}_1) = \text{span}(\mathbf{H}_{32}\mathbf{V}_2) \quad (3.3)$$

$$\text{span}(\mathbf{H}_{41}\mathbf{V}_1) = \text{span}(\mathbf{H}_{42}\mathbf{V}_2). \quad (3.4)$$

Considering equal number of dimensions at all nodes, as it will be clear further on, the channel matrices are square and thus invertible, and, solving the above relationships for \mathbf{V}_1 and \mathbf{V}_2 respectively, we have

$$\text{span}(\mathbf{V}_1) = \text{span}(\mathbf{H}_{31}^{-1}\mathbf{H}_{32}\mathbf{V}_2) \quad (3.5)$$

$$\text{span}(\mathbf{V}_2) = \text{span}(\mathbf{H}_{42}^{-1}\mathbf{H}_{41}\mathbf{V}_1) \quad (3.6)$$

and, substituting for \mathbf{V}_2 in the first one and introducing the transformation $\tilde{\mathbf{T}}_1 = \mathbf{H}_{31}^{-1}\mathbf{H}_{32}\mathbf{H}_{42}^{-1}\mathbf{H}_{41}$, we can further write

$$\text{span}(\mathbf{V}_1) = \text{span}(\mathbf{H}_{31}^{-1}\mathbf{H}_{32}\mathbf{H}_{42}^{-1}\mathbf{H}_{41}\mathbf{V}_1) = \text{span}(\tilde{\mathbf{T}}_1\mathbf{V}_1). \quad (3.7)$$

Analogously, the same should happen with all the other transmitters and receivers so that each alignment constraint implies a new constraint on \mathbf{V}_1 like (3.7), that must be satisfied at the same time, so that:

$$\text{span}(\mathbf{V}_1) = \text{span}(\tilde{\mathbf{T}}_1\mathbf{V}_1) = \text{span}(\tilde{\mathbf{T}}_2\mathbf{V}_1) = \dots = \text{span}(\tilde{\mathbf{T}}_L\mathbf{V}_1) \quad (3.8)$$

for an increasing number of constraints L as the number of users K increases. For further details we refer to [2] and [7].

At the time of writing of this thesis, closed form solutions of the interference alignment problem are not known in general and exist only in certain cases. In the following, we investigate closed form solutions for the K user interference channel, when the nodes are equipped with only one or more antennas. The solution for the former case is established on beamforming over multiple symbol extensions of the original channel, while the solution in the latter resorts to eigenvectors and exist only for the three user channel. When the nodes are equipped with multiple antennas we also consider distributed algorithms that permit to achieve the alignment of interference iteratively.

3.2 Interference Alignment for SISO Systems

We first consider an interference network consisting of K single antenna nodes. In order to construct interference alignment schemes in a network with nodes equipped with one antenna, we must consider symbol extensions of the original channel.

Following [2], we first denote the M symbols transmitted over M time (or frequency) slots as a supersymbol. According to the notation of Section 2.5 and indicating explicitly the time index t , the symbol extensions of the transmitted symbol s_i is hence defined as:

$$\mathbf{s}_i(t) = \begin{bmatrix} s_i(M(t-1)+1) \\ s_i(M(t-1)+2) \\ \vdots \\ s_i(Mt) \end{bmatrix}. \quad (3.9)$$

Analogously, considering the M symbol extensions of the original channel between each transmitter and receiver, each channel path between every couple of transmitter and receiver is described by a $M \times M$ diagonal matrix. The elements on the diagonal are independent identically distributed complex Gaussian random variables with zero means and unit variances, bounded between a nonzero minimum value and a finite maximum value, representing the channel fading coefficient in each time slot or frequency band.

There is no distinction if symbols extensions are considered in the time domain (in which case they represent different time slots in a time-varying channel) or in the frequency domain (where they represent orthogonal frequency bands in a frequency-selective channel). From the degrees of freedom point of view, the optimality of this scheme is then achieved only asymptotically, requiring long symbol extensions [2].

As in Section 2.5 we indicate the number of information streams transmitted by transmitter i as d_i . The beamforming matrix \mathbf{V}_i has dimensions $M \times d_i$ and similarly the interference suppression matrix \mathbf{U}_i^H is $d_i \times M$.

In the extended channel the d_i independent data symbols transmitted at time t , given by $x_i^{(k)}(t)$ $k = 1, 2, \dots, d_i$ are precoded with the $M \times d_i$ matrix $\mathbf{V}_i(t)$. In other words, the k th column vector of the matrix $\mathbf{V}_i(t)$, indicated by $\mathbf{V}_{i[\star k]}(t)$, indicates the beamforming vector along which the k th symbol, out of d_i , is sent. We can further write:

$$\mathbf{s}_i(t) = \sum_{k=1}^{d_i} x_i^{(k)}(t) \mathbf{V}_{i[\star k]}(t) = \mathbf{V}_i(t) \mathbf{x}_i(t). \quad (3.10)$$

At receiver 1, in order to obtain d_1 interference-free dimensions from a total of M , we must ensure that the total interference does not spread over more than $M - d_1$ dimensions. In order to have this, the interference from transmitters $\{2, 3, \dots, K\}$ must be perfectly aligned at receiver 1, which is expressed by the following condition:

$$\mathbf{H}_{12} \mathbf{V}_2 = \mathbf{H}_{13} \mathbf{V}_3 = \mathbf{H}_{14} \mathbf{V}_4 = \dots = \mathbf{H}_{1K} \mathbf{V}_K. \quad (3.11)$$

At receiver 2, to obtain d_2 interference-free dimensions, we must ensure that the subspace spanned by the interference from transmitter 1 contains all the interference caused by the others $K - 2$ transmitters. This is expressed by the following conditions:

$$\begin{aligned} \mathbf{H}_{23} \mathbf{V}_3 &\prec \mathbf{H}_{21} \mathbf{V}_1 \\ \mathbf{H}_{24} \mathbf{V}_4 &\prec \mathbf{H}_{21} \mathbf{V}_1 \\ &\vdots \\ \mathbf{H}_{2K} \mathbf{V}_K &\prec \mathbf{H}_{21} \mathbf{V}_1 \end{aligned} \quad (3.12)$$

where $\mathbf{A} \prec \mathbf{B}$ means that the column space of \mathbf{A} is included in that of \mathbf{B} . Conditions similar to (3.12) must be satisfied at all the remaining $K - 2$ receivers, so that all the interference at each of these receivers lays in the same d_1 dimensional subspace. In other words, the following relations must be satisfied:

$$\mathbf{H}_{ij} \mathbf{V}_j \prec \mathbf{H}_{i1} \mathbf{V}_1, \quad \forall i = \{3, 4, \dots, K\}, j \neq \{1, i\}. \quad (3.13)$$

Once we find precoding matrices that verify the above conditions, we ensure that all the interference vectors are aligned at each receiver. However this is not enough as we must also verify that the components of the desired signal are linearly independent of the components of interference at all the receivers, so that decoding of the original information streams is possible by simply zero-forcing the interference.

At the i th receiver, the components containing the desired signal are indicated by $\mathbf{H}_{ii}\mathbf{V}_i$ while the interference is given by $\mathbf{H}_{ij}\mathbf{V}_j \forall j \neq i$. If we assume that (3.11)–(3.13) are satisfied, it must be verified that the columns of the $M \times M$ dimensional matrix

$$[\mathbf{H}_{ii}\mathbf{V}_i \quad \mathbf{H}_{ij}\mathbf{V}_j] \quad (3.14)$$

are linearly independent for a given j . For instance, at the first receiver we should show that the square matrix $[\mathbf{H}_{11}\mathbf{V}_1 \quad \mathbf{H}_{12}\mathbf{V}_2]$ has rank M and similarly we should do at the second receiver with the matrix $[\mathbf{H}_{22}\mathbf{V}_2 \quad \mathbf{H}_{21}\mathbf{V}_1]$ and so on at all the remaining receivers. It is here that the assumption of varying channels is needed since without that it would not be possible, in the SISO case, to prove the independence of the vectors carrying the desired signal from the interference vectors. For the detailed proof, we refer the interested reader to [2].

3.2.1 Closed form original beamforming design

We show in this section the beamforming design as originally presented in the original paper [2].

It is important to note that it is not possible to construct an interference alignment scheme for any given multiplexing gains (d_1, d_2, \dots, d_K) over any M dimensional signal space. In fact, all the dimensions of interest are dependent on the number of users in the system and, as the number of users increase, the dimension of the space over which we are aligning the interference must increase as well.

Assuming that a nonnegative integer n is given, the following relations hold for a K users interference alignment system:

$$N = (K - 1)(K - 2) - 1 \quad (3.15)$$

$$M = (n + 1)^N + n^N \quad (3.16)$$

$$d_1 = (n + 1)^N \quad (3.17)$$

$$d_i = n^N \quad i = 2, 3, \dots, K. \quad (3.18)$$

Note that $d_1 > d_2 = d_3 = \dots = d_K$, as equations (3.11)–(3.13) imply.

In order to find precoding matrices that obey the constraints for the alignment of interference stated above, we now express these conditions in an equivalent form. First of all we define:

$$\mathbf{B} = (\mathbf{H}_{21})^{-1} \mathbf{H}_{23} \mathbf{V}_3 \quad (3.19)$$

$$\mathbf{S}_j = (\mathbf{H}_{1j})^{-1} \mathbf{H}_{13} (\mathbf{H}_{23})^{-1} \mathbf{H}_{21} \quad \forall j = \{2, 3, \dots, K\} \quad (3.20)$$

$$\mathbf{T}_j^{[i]} = (\mathbf{H}_{i1})^{-1} \mathbf{H}_{ij} \mathbf{S}_j \quad \forall i, j = \{2, 3, \dots, K\}, j \neq i, \quad (3.21)$$

Note that since here we are building an interference alignment scheme using symbols extensions, the channel matrices \mathbf{H}_{ij} are diagonal and full rank [2], so they are certainly invertible. Similarly, the $\mathbf{T}_j^{[k]}$ are full rank $\forall j, k$ and moreover $\mathbf{T}_a^{[b]} \neq \mathbf{T}_c^{[d]}$ for $a \neq c$ or $b \neq d$, since the channel coefficients on the diagonal are assumed to be drawn i.i.d. from a Gaussian distribution. We can now equivalently formulate (3.11)–(3.13) as:

$$\text{At the first receiver:} \quad \mathbf{V}_j = \mathbf{S}_j \mathbf{B} \quad \forall j = \{2, 3, \dots, K\} \quad (3.22)$$

$$\text{At the second receiver:} \quad \left\{ \begin{array}{l} \mathbf{T}_3^{[2]} \mathbf{B} = \mathbf{B} \prec \mathbf{V}_1 \\ \mathbf{T}_4^{[2]} \mathbf{B} \prec \mathbf{V}_1 \\ \vdots \\ \mathbf{T}_K^{[2]} \mathbf{B} \prec \mathbf{V}_1 \end{array} \right. \quad (3.23)$$

$$\text{At the } k\text{th receiver: } \left\{ \begin{array}{l} \mathbf{T}_2^{[k]} \mathbf{B} \prec \mathbf{V}_1 \\ \mathbf{T}_3^{[k]} \mathbf{B} \prec \mathbf{V}_1 \\ \vdots \\ \mathbf{T}_{k-1}^{[k]} \mathbf{B} \prec \mathbf{V}_1 \\ \mathbf{T}_{k+1}^{[k]} \mathbf{B} \prec \mathbf{V}_1 \\ \vdots \\ \mathbf{T}_K^{[k]} \mathbf{B} \prec \mathbf{V}_1 \end{array} \right. \quad \forall k = \{3, 4, \dots, K\}. \quad (3.24)$$

We now wish to pick matrices \mathbf{V}_1 and \mathbf{B} so that they satisfy the $(K-2)$ conditions in (3.23) and the $(K-2)(K-2)$ conditions expressed by (3.24), for a total of $(K-2)(K-1) = N+1$ constraints, and then use Equation (3.22) to specify $\mathbf{V}_2, \mathbf{V}_3, \dots, \mathbf{V}_K$.

The goal is therefore choosing $d_1 = (n+1)^N$ column vectors for \mathbf{V}_1 and $d_3 = n^N$ columns vectors for \mathbf{B} so that $\mathbf{T}_j^{[i]} \mathbf{B} \prec \mathbf{V}_1 \quad \forall i, j = \{2, 3, \dots, K\}, j \neq i$. The matrices \mathbf{B} and \mathbf{V}_1 are hence chosen to be:

$$\mathbf{B} = \left\{ \left(\prod_{k,l \in \{2,3,\dots,K\}, k \neq l, (k,l) \neq (2,3)} \left(\mathbf{T}_l^{[k]} \right)^{\alpha_{kl}} \right) \mathbf{w} \mid \forall \alpha_{kl} \in \{0, 1, 2, \dots, n-1\} \right\} \quad (3.25)$$

$$\mathbf{V}_1 = \left\{ \left(\prod_{k,l \in \{2,3,\dots,K\}, k \neq l, (k,l) \neq (2,3)} \left(\mathbf{T}_l^{[k]} \right)^{\alpha_{kl}} \right) \mathbf{w} \mid \forall \alpha_{kl} \in \{0, 1, 2, \dots, n\} \right\}. \quad (3.26)$$

For instance, if $K=3$ we get $N=1$ and \mathbf{B} and \mathbf{V}_1 are given by:

$$\mathbf{B} = \left[\mathbf{w} \quad \mathbf{T}_2^{[3]} \mathbf{w} \quad \left(\mathbf{T}_2^{[3]} \right)^2 \mathbf{w} \quad \dots \quad \left(\mathbf{T}_2^{[3]} \right)^{n-1} \mathbf{w} \right] \quad (3.27)$$

$$\mathbf{V}_1 = \left[\mathbf{w} \quad \mathbf{T}_2^{[3]} \mathbf{w} \quad \left(\mathbf{T}_2^{[3]} \right)^2 \mathbf{w} \quad \dots \quad \left(\mathbf{T}_2^{[3]} \right)^n \mathbf{w} \right] \quad (3.28)$$

Instead, if $K=4$ we get $N=5$. Assuming $n=1$, \mathbf{B} has $n^N = 1$ column and

\mathbf{V}_1 has $(n+1)^N = 32$ columns, and we have

$$\begin{aligned} \mathbf{B} &= \begin{bmatrix} \mathbf{w} \end{bmatrix} \\ \mathbf{V}_1 &= \begin{bmatrix} \mathbf{w} & \mathbf{T}_2^{[3]}\mathbf{w} & \mathbf{T}_4^{[2]}\mathbf{w} & \mathbf{T}_4^{[3]}\mathbf{w} & \mathbf{T}_3^{[4]}\mathbf{w} & \mathbf{T}_2^{[4]}\mathbf{w} \\ \mathbf{T}_2^{[3]}\mathbf{T}_4^{[2]}\mathbf{w} & \mathbf{T}_2^{[3]}\mathbf{T}_4^{[3]}\mathbf{w} & \dots & \mathbf{T}_2^{[3]}\mathbf{T}_2^{[4]}\mathbf{w} \\ \mathbf{T}_2^{[3]}\mathbf{T}_4^{[2]}\mathbf{T}_4^{[3]}\mathbf{w} & \dots & \mathbf{T}_2^{[3]}\mathbf{T}_4^{[2]}\mathbf{T}_4^{[3]}\mathbf{T}_3^{[4]}\mathbf{T}_2^{[4]}\mathbf{w} \end{bmatrix}. \end{aligned} \quad (3.29)$$

$$(3.30)$$

so that the column vectors of \mathbf{V}_1 assume the form:

$$(\mathbf{T}_2^{[3]})^{\alpha_{32}} (\mathbf{T}_4^{[2]})^{\alpha_{24}} (\mathbf{T}_4^{[3]})^{\alpha_{34}} (\mathbf{T}_3^{[4]})^{\alpha_{43}} (\mathbf{T}_2^{[4]})^{\alpha_{42}} \mathbf{w} \quad (3.31)$$

where all $\alpha_{32}, \alpha_{24}, \alpha_{34}, \alpha_{43}, \alpha_{42}$ take values 0 or 1, for a total of $2^5 = 32$ possible combinations. Once we have determined \mathbf{B} and \mathbf{V}_1 , we select $\mathbf{V}_j = \mathbf{S}_j \mathbf{B}$, $\forall j = \{2, 3, \dots, K\}$, so that the conditions for the alignment of the interference at all the receivers are satisfied.

Assume that there exist \mathbf{V}_k , $\forall k = 1, 2, \dots, K$ verifying the conditions in (3.22)–(3.24) and the parameters of the system are determined by equations (3.15)–(3.18). When each transmitter sends d_k information streams using the corresponding beamforming matrix \mathbf{V}_k , and each receiver decodes the desired streams zero-forcing the interference using the corresponding \mathbf{U}_k^H , the multiplexing gain of

$$r^{[0]} = \frac{(K-1)d_3 + d_1}{d_3 + d_1} = \frac{(K-1)n^N + (n+1)^N}{n^N + (n+1)^N} \quad (3.32)$$

is achievable for any nonnegative integer n in the K user SISO fading interference channel. As n tends to infinity, the interference alignment scheme asymptotically achieves the optimal multiplexing gain of $K/2$.

3.2.2 Closed form efficient beamforming design

The motivation for the efficient beamforming design presented in [5] comes directly from the (3.19)–(3.24). On one part these equations facilitate the

investigation and the construction of the beamforming matrices, on the other part they are clearly redundant and recursive. As a matter of fact, the $\mathbf{T}_j^{[i]}$ are defined through the \mathbf{S}_j , and also the conditions for the alignment of the interference at each receiver are given using the $\mathbf{T}_j^{[i]}$ and the matrix \mathbf{B} , which is in turn specified through \mathbf{V}_3 .

To further motivate the efficient beamforming design that we are presenting here, consider for now only the first three nodes in the network. The constraints that must be satisfied are:

$$\text{At the first receiver:} \quad \mathbf{H}_{12}\mathbf{V}_2 = \mathbf{H}_{13}\mathbf{V}_3 \quad (3.33)$$

$$\text{At the second receiver:} \quad \text{span}(\mathbf{H}_{23}\mathbf{V}_3) = \text{span}(\mathbf{H}_{21}\mathbf{V}_1) \quad (3.34)$$

$$\text{At the third receiver:} \quad \text{span}(\mathbf{H}_{32}\mathbf{V}_2) = \text{span}(\mathbf{H}_{31}\mathbf{V}_1). \quad (3.35)$$

Merging the first and the third together, we have:

$$\begin{aligned} \text{span}(\mathbf{V}_1) &= \text{span}(\mathbf{H}_{31}^{-1}\mathbf{H}_{32}\mathbf{V}_2) \\ &= \text{span}(\mathbf{H}_{31}^{-1}\mathbf{H}_{32}\mathbf{H}_{12}^{-1}\mathbf{H}_{13}\mathbf{V}_3) \\ &= \text{span}(\widehat{\mathbf{T}}_3^{[2]}\mathbf{V}_3) \end{aligned} \quad (3.36)$$

where we have introduced $\widehat{\mathbf{T}}_3^{[2]} = \mathbf{H}_{31}^{-1}\mathbf{H}_{32}\mathbf{H}_{12}^{-1}\mathbf{H}_{13}$. Since we assume that $d_1 > d_i \forall i \in \{2, \dots, K\}$, Equation (3.36) is rewritten as $\widehat{\mathbf{T}}_3^{[2]}\mathbf{V}_3 \prec \mathbf{V}_1$ so it should be clear that resorting to matrices \mathbf{S}_j , $\mathbf{T}_j^{[i]}$ and \mathbf{B} introduced in the previous section is not necessary. We wish now to find interference alignment conditions equivalent to the original ones (3.11)–(3.13) that permit to specify the precoders without using auxiliary matrices.

We first define:

$$\widehat{\mathbf{T}}_j^{[k]} = (\mathbf{H}_{k1})^{-1}\mathbf{H}_{kj}(\mathbf{H}_{1j})^{-1}\mathbf{H}_{13}, \quad \forall j, k = \{2, 3, \dots, K\}, j \neq k \quad (3.37)$$

and then, repeating what we have done in (3.36) for all the receivers or alternatively rewriting the (3.22)–(3.24) using the just defined $\widehat{\mathbf{T}}_j^{[k]}$, we find the following equivalent conditions.

$$\text{At the first receiver:} \quad \mathbf{V}_i = (\mathbf{H}_{1i})^{-1}\mathbf{H}_{13}\mathbf{V}_3 \quad \forall i \neq \{1, 3\} \quad (3.38)$$

$$\text{At the second receiver: } \left\{ \begin{array}{l} \widehat{\mathbf{T}}_3^{[2]} \mathbf{V}_3 \prec \mathbf{V}_1 \\ \widehat{\mathbf{T}}_4^{[2]} \mathbf{V}_3 \prec \mathbf{V}_1 \\ \vdots \\ \widehat{\mathbf{T}}_K^{[2]} \mathbf{V}_3 \prec \mathbf{V}_1 \end{array} \right. \quad (3.39)$$

$$\text{At the } k\text{th receiver: } \left\{ \begin{array}{l} \widehat{\mathbf{T}}_2^{[k]} \mathbf{V}_3 \prec \mathbf{V}_1 \\ \widehat{\mathbf{T}}_2^{[k]} \mathbf{V}_3 \prec \mathbf{V}_1 \\ \vdots \\ \widehat{\mathbf{T}}_{k-1}^{[k]} \mathbf{V}_3 \prec \mathbf{V}_1 \\ \widehat{\mathbf{T}}_{k+1}^{[k]} \mathbf{V}_3 \prec \mathbf{V}_1 \\ \widehat{\mathbf{T}}_{k+2}^{[k]} \mathbf{V}_3 \prec \mathbf{V}_1 \\ \vdots \\ \widehat{\mathbf{T}}_K^{[k]} \mathbf{V}_3 \prec \mathbf{V}_1 \end{array} \right. \quad \forall k \neq \{1, 2\}. \quad (3.40)$$

The beamforming matrices for the efficient interference alignment that satisfy the equivalent conditions (3.38)–(3.40) are therefore given by:

$$\mathbf{V}_3 = \left\{ \left(\widehat{\mathbf{T}}_3^{[2]} \right)^{-1} \prod_{k,l \in \{2, \dots, K\}, k \neq l, (k,l) \neq (2,3)} \left(\left(\widehat{\mathbf{T}}_3^{[2]} \right)^{-1} \widehat{\mathbf{T}}_l^{[k]} \right)^{n_{kl}} \mathbf{w} \mid \sum_{k,l \in \{2, \dots, K\}, k \neq l, (k,l) \neq (2,3)} n_{kl} \leq n^* \right\} \quad (3.41)$$

$$\mathbf{V}_1 = \left\{ \prod_{k,l \in \{2, \dots, K\}, k \neq l, (k,l) \neq (2,3)} \left(\left(\widehat{\mathbf{T}}_3^{[2]} \right)^{-1} \widehat{\mathbf{T}}_l^{[k]} \right)^{n_{kl}} \mathbf{w} \mid \sum_{k,l \in \{2, \dots, K\}, k \neq l, (k,l) \neq (2,3)} n_{kl} \leq n^* + 1 \right\} \quad (3.42)$$

$$\mathbf{V}_i = \left(\mathbf{H}_{1i} \right)^{-1} \mathbf{H}_{13} \mathbf{V}_3 \quad \forall i \neq \{1, 3\}. \quad (3.43)$$

Here as before, the parameters of the system are related to each other through relations similar to the (3.15)–(3.18). Assuming that the nonnegative

integer n^* is given, the following constraints hold:

$$N = (K - 1)(K - 2) - 1 \quad (3.44)$$

$$M = 2n^* + N + 2 \quad (3.45)$$

$$d_1 = \binom{n^* + N + 1}{N} \quad (3.46)$$

$$d_i = \binom{n^* + N}{N} \quad \forall i = \{2, 3, \dots, K\}. \quad (3.47)$$

Assume that there exist $\mathbf{V}_k, \forall k = 1, 2, \dots, K$ verifying the conditions in (3.38)–(3.40) and the parameters of the system are determined by equations (3.44)–(3.47). When each transmitter sends d_k information streams using the corresponding beamforming matrix \mathbf{V}_k , and each receiver decodes the desired streams zero-forcing the interference using the corresponding \mathbf{U}_k^H , the multiplexing gain of

$$r^{[1]} = \frac{(K - 1)d_3 + d_1}{d_3 + d_1} = \frac{(K - 1)(n^* + 1) + n^* + N + 1}{2n^* + N + 2} \quad (3.48)$$

is achievable for any nonnegative integer n^* in the K user SISO fading interference channel. As n^* tends to infinity, the interference alignment scheme asymptotically achieves the optimal multiplexing gain of $K/2$.

The beamforming design criterion that we have presented in this section is more efficient than the original one presented in Section 3.2.1 when $K \geq 4$. For any given number of channel uses, the achievable multiplexing gain $r^{[1]}$ is strictly higher than the original one $r^{[0]}$ since the transmit precoding matrices are designed such that d_1/d_3 becomes closer to 1, while satisfying the interference alignment conditions.

3.2.3 On the optimality of IA for SISO systems

When the K nodes in the network are equipped with only one antenna, the sum capacity per user is $\frac{1}{2} \log(\rho) + o(\log(\rho))$ so that, at high SNR we can achieve 1/2 degrees of freedom per user, so that the optimal multiplexing gain of the network is $K/2$, at high SNR. In the previous sections we have shown

that the construction of interference alignment schemes based on beamforming over multiple symbol extensions is necessary when we are dealing with networks comprised of single antenna nodes.

The interference alignment schemes described here do not exactly attain the optimal multiplexing gain when the beamforming is built over finite symbol extensions but instead they approach arbitrarily close to the optimal bound by increasing the length of the symbol extensions.

Consider for instance an interference network with $K = 3$ users. Using the original beamforming design criterion, it has been shown that the multiplexing gain (3.32) of the network is equal to $\frac{3n+1}{2n+1}$ for any integer n . With $n = 1$, for example, the first user transmits two independent symbols per channel use while the other two transmit only one symbol. Thus four degrees of freedom are attainable over a three symbol extensions of the channel so that a total multiplexing gain of $4/3$ is achieved per channel use.

As stated in [2], in order to achieve $1/2$ degrees of freedom per user, each receiver must be able to split the signal space in two subspaces, one containing only the desired signal while all the interference lays in other one. Intuitively, the suboptimality of the scheme can be explained saying that when we construct interference alignment schemes with finite values of n , not all the interference terms align perfectly at each receiver within exactly half of the total signal space.

Moreover, nothing or very little have been reported on the practical realization of interference alignment schemes in networks composed of single antenna nodes and on its intrinsic difficulties, which are mainly related with the dimensionality of the matrices when n is large and with the unavoidable limit of dealing, in real systems, with finite values of SNR.

3.3 Interference Alignment for MIMO Systems

We consider now a network whose nodes are equipped with multiple antennas. The three user interference channel is particularly attractive as, unlike the case of single antennas nodes where the optimal multiplexing gain is achievable only asymptotically, it is proved in [2] that the three user interference channel with M antennas at each node has exactly $3M/2$ degrees of freedom. In other words we do not need to recur to symbol extensions in order to achieve the optimal value.

The system model of Section 2.5 is still valid here and we further assume that at each node the number of transmitting antennas is equal to the number of receiving antennas, so that $N_T = N_R = M$. The number of interference-free information streams available for each pair of transmitter and receiver is equal to $M/2$, so we set $d_i = M/2 \forall i$.

Similarly to what we did in Section 3.2, we wish to find the beamforming matrices \mathbf{V}_i so that the dimension of interference is equal to $M/2$ at all the receivers. Since the only closed form solutions found for the MIMO interference channel are for the case of $K = 3$ users, we henceforth focus on this case.

3.3.1 Closed form beamforming design for three users MIMO

In a three user interference channel when the nodes are equipped with M antennas, the multiplexing gain of $\frac{3M}{2}$ is exactly achievable without the need of symbol extensions. The i th transmitter sends $\frac{M}{2}$ independent streams \mathbf{x}_i , that are beamformed over the M available antennas using the $M \times \frac{M}{2}$ matrix \mathbf{V}_i , and received by receiver k through the channel described by the $M \times M$ matrix \mathbf{H}_{ki} . The i th receiver decodes the desired $\frac{M}{2}$ streams from the $M \times 1$ received signal vector, zero-forcing the interference with the $\frac{M}{2} \times M$ matrix \mathbf{U}_i^H .

In order to decode $\frac{M}{2}$ data streams, the interference at each receiver

should have no more than $\frac{M}{2}$ dimensions over a total signal space of M dimensions and be linearly independent with the desired signal, conditions ensured by three interference alignment constraints expressed as:

$$\text{At the first receiver:} \quad \text{span}(\mathbf{H}_{12}\mathbf{V}_2) = \text{span}(\mathbf{H}_{13}\mathbf{V}_3) \quad (3.49)$$

$$\text{At the second receiver:} \quad \text{span}(\mathbf{H}_{21}\mathbf{V}_1) = \text{span}(\mathbf{H}_{23}\mathbf{V}_3) \quad (3.50)$$

$$\text{At the third receiver:} \quad \text{span}(\mathbf{H}_{31}\mathbf{V}_1) = \text{span}(\mathbf{H}_{32}\mathbf{V}_2). \quad (3.51)$$

Then, in order to find explicit forms for the beamforming matrices, the above are restricted as

$$\text{span}(\mathbf{H}_{12}\mathbf{V}_2) = \text{span}(\mathbf{H}_{13}\mathbf{V}_3) \quad (3.52)$$

$$\mathbf{H}_{21}\mathbf{V}_1 = \mathbf{H}_{23}\mathbf{V}_3 \quad (3.53)$$

$$\mathbf{H}_{31}\mathbf{V}_1 = \mathbf{H}_{32}\mathbf{V}_2 \quad (3.54)$$

which in turn, solving the last two equations for \mathbf{V}_3 and \mathbf{V}_2 respectively, and substituting for them in the first one, become

$$\text{span}(\mathbf{V}_1) = \text{span}(\mathbf{E}\mathbf{V}_1) \quad (3.55)$$

$$\mathbf{V}_2 = (\mathbf{H}_{32})^{-1}\mathbf{H}_{31}\mathbf{V}_1 \quad (3.56)$$

$$\mathbf{V}_3 = (\mathbf{H}_{23})^{-1}\mathbf{H}_{21}\mathbf{V}_1 \quad (3.57)$$

where

$$\mathbf{E} = (\mathbf{H}_{31})^{-1}\mathbf{H}_{32}(\mathbf{H}_{12})^{-1}\mathbf{H}_{13}(\mathbf{H}_{23})^{-1}\mathbf{H}_{21}. \quad (3.58)$$

Let $\mathbf{e}_1, \mathbf{e}_2, \dots, \mathbf{e}_M$ be the M eigenvectors of \mathbf{E} , then we set \mathbf{V}_1 to be:

$$\mathbf{V}_1 = [\mathbf{e}_1 \ \mathbf{e}_2 \ \dots \ \mathbf{e}_{M/2}]. \quad (3.59)$$

Then \mathbf{V}_2 and \mathbf{V}_3 are consequently determined by (3.56)–(3.57).

The respective interference suppression matrices are then obtained as in the SISO case computing the null space of the received interference.

3.3.2 Iterative Interference Alignment

When the nodes in the network are equipped with multiple antennas, solutions to the interference alignment problem, in the form of closed form expressions for the transmit precoding matrices, are still unknown for networks with more than three users. Despite this, there exist algorithms that permit to iteratively solve the interference alignment problem. In [3] two distributed algorithms has been proposed in order to find the beamforming precoders and the interference suppression matrices that align the interference at all the receivers in networks with an arbitrary number of nodes and multiple antennas at each node.

The key idea exploited in the design of these algorithms is the reciprocity of the propagation channel. The reciprocal network is simply obtained by switching the roles of the transmitters and the receivers. Assuming reciprocity, in particular, we ensure that the same set of signal-to-interference-plus-noise (SINR) ratios are achievable in the reciprocal network with the same transmit power and that the signalling directions along which a receiver undergoes the least interference from the undesired transmitters are the same directions along which this node will cause the least interference to its undesired receivers in the reciprocal network. The approach taken here is cognitive as each transmitter in the network tries to generate the least interference possible to the other nodes in the network rather than simply trying to do its best for its desired receiver.

Furthermore, the algorithms that we are going to present require only local channel knowledge at each receiving node that is, specifically, the direct channel matrix to its desired transmitter and the effective noise covariance matrix, consisting of the AWGN noise and the effective interference due by all the other undesired transmitters. These algorithms are distributed since at each iteration they globally update the interference suppression matrices of all the receivers until convergence is achieved. Convergence is achieved iteratively by switching between the original and the reciprocal networks and updating at each iteration only the receiving filters.

While the goal of the first algorithm is to attain perfect alignment by minimizing the total interference experienced by all the receivers, the second algorithm maximizes the SINR at each receiver. Before presenting the algorithm, we introduce some notations and definitions that we will use later. As before, the received signal at receiver k after interference suppression is given by

$$\mathbf{y}_i = \mathbf{U}_i^H \mathbf{H}_{ii} \mathbf{V}_i \mathbf{x}_i + \sum_{j=1, j \neq i}^K \mathbf{U}_i^H \mathbf{H}_{ij} \mathbf{V}_j \mathbf{x}_j + \mathbf{U}_i^H \mathbf{n}_i \quad (3.60)$$

and in parallel we can define the received signal in the reciprocal network as

$$\overleftarrow{\mathbf{y}}_i = \overleftarrow{\mathbf{U}}_i^H \overleftarrow{\mathbf{H}}_{ii} \overleftarrow{\mathbf{V}}_i \overleftarrow{\mathbf{x}}_i + \sum_{j=1, j \neq i}^K \overleftarrow{\mathbf{U}}_i^H \overleftarrow{\mathbf{H}}_{ij} \overleftarrow{\mathbf{V}}_j \overleftarrow{\mathbf{x}}_j + \overleftarrow{\mathbf{U}}_i^H \overleftarrow{\mathbf{n}}_i \quad (3.61)$$

where all the variables $\overleftarrow{\mathbf{U}}_i$, $\overleftarrow{\mathbf{H}}_{ij}$, $\overleftarrow{\mathbf{V}}_i \forall i, j$ have the same meaning as their counterpart in the original network. In particular the channel matrices in the reciprocal network are defined as: $\overleftarrow{\mathbf{H}}_{ij} = \mathbf{H}_{ji}^H$. We assume the transmit power of transmitter i in the reciprocal network to be equal to the transmit power in the original network $\mathbb{E}[\overleftarrow{\mathbf{x}}_i^H \overleftarrow{\mathbf{x}}_i] = \overleftarrow{P}_i = P_i$ where P_i is the transmit power at transmitter i in the original channel. In order to exploit the reciprocity later we will also impose $\overleftarrow{\mathbf{U}}_i = \mathbf{V}_i$ and $\overleftarrow{\mathbf{V}}_i = \mathbf{U}_i \forall i$.

The total interference leakage at each receiver is the power of the interference remaining in the desired signal subspace after the interference suppression filter is applied. It can therefore be viewed as a measure of the quality of the interference alignment scheme and ideally we want it to be zero. The total interference leakage at receiver i is defined as

$$I_i = \text{Tr}[\mathbf{U}_i^H \mathbf{Q}_i \mathbf{U}_i] \quad (3.62)$$

where \mathbf{Q}_i is the interference covariance matrix at receiver i :

$$\mathbf{Q}_i = \sum_{j=1, j \neq i}^K \frac{P_j}{d_j} \mathbf{H}_{ij} \mathbf{V}_j \mathbf{V}_j^H \mathbf{H}_{ij}^H \quad (3.63)$$

We now define the SINR of the k th stream of the i th receiver as

$$\text{SINR}_{ik} = \sum_{j=1, j \neq i}^K \frac{P_j \mathbf{U}_{i[\star k]}^H \mathbf{H}_{ii} \mathbf{V}_{i[\star k]} \mathbf{V}_{i[\star k]}^H \mathbf{H}_{ii}^H \mathbf{U}_{i[\star k]}}{d_i \mathbf{U}_{i[\star k]}^H \mathbf{B}_{ik} \mathbf{U}_{i[\star k]}} \quad \forall i = 1, \dots, K, \forall k = 1, \dots, d_i \quad (3.64)$$

where we use again the notation $\mathbf{A}_{[\star k]}$ to denote the k th column of the matrix \mathbf{A} . The numerator indicates the power of the considered k th stream of the i th receiver after filtering by the interference suppression matrix and the denominator is the sum of the powers of interference and noise, after the suppression of the interference. The matrix \mathbf{B}_{ik} is the interference plus noise covariance matrix for the considered stream:

$$\mathbf{B}_{ik} = \sum_{j=1}^K \frac{P_j}{d_j} \sum_{k=1}^{d_j} \mathbf{H}_{ij} \mathbf{V}_{j[\star d]} \mathbf{V}_{j[\star d]}^H \mathbf{H}_{ij}^H - \frac{P_i}{d_i} \mathbf{H}_{ii} \mathbf{V}_{i[\star k]} \mathbf{V}_{i[\star k]}^H \mathbf{H}_{ii}^H + \mathbf{I}_{N_T} \quad \forall i = 1, \dots, K, \forall k = 1, \dots, d_i. \quad (3.65)$$

In the above equation, the first term is the total power of the streams transmitted in the network by all the transmitters to which it must be subtract the power of the desired stream. The third term indicates the power of the noise and it is given by the identity matrix since we are assuming that the noise variances at each node are normalized to unit. If this does not hold, the variance of the noise $\sigma_{n_i}^2$ at node i will compare as a multiplicative factor in front of the identity matrix. Beside these we can define the analogous quantities with the same meanings in the reciprocal network.

An important consideration that comes from the duality approach taken here is that setting $\overleftarrow{\mathbf{U}}_i = \mathbf{V}_i$ and $\overleftarrow{\mathbf{V}}_i = \mathbf{U}_i \forall i$ the feasibility conditions in the reciprocal network turn to be the same as the feasibility conditions in the original network. To depict this, consider the feasibility conditions in the reciprocal network and substitute for $\overleftarrow{\mathbf{U}}_i$, $\overleftarrow{\mathbf{V}}_i$ and $\overleftarrow{\mathbf{H}}_{ij}$. We get:

$$\begin{aligned} \overleftarrow{\mathbf{U}}_i^H \overleftarrow{\mathbf{H}}_{ij} \overleftarrow{\mathbf{V}}_j &= 0 \iff \mathbf{V}_i^H \mathbf{H}_{ji}^H \mathbf{U}_j = 0 \quad \forall j \neq i \\ \text{rank}(\overleftarrow{\mathbf{U}}_i^H \overleftarrow{\mathbf{H}}_{ii} \overleftarrow{\mathbf{V}}_i) &= d_i \iff \text{rank}(\mathbf{V}_i^H \mathbf{H}_{ii}^H \mathbf{U}_i) = d_i \quad \forall i = 1, \dots, K \end{aligned} \quad (3.66)$$

which are equivalent to the feasibility conditions for the original channel, given by:

$$\begin{aligned} \mathbf{U}_i^H \mathbf{H}_{ij} \mathbf{V}_j &= 0 \quad \forall j \neq i \\ \text{rank}(\mathbf{U}_i^H \mathbf{H}_{ii} \mathbf{V}_i) &= d_i \quad \forall i = 1, \dots, K. \end{aligned} \quad (3.67)$$

As a consequence of this consideration is the reciprocity property of alignment which states that if a degrees of freedom distribution is feasible in the original interference channel then it is also feasible in the reciprocal network when the transmit filter and receive filter in the dual network are chosen to be respectively the receive filters and the transmit filters of the original channel.

Note that if the condition on the suppression of all the interference is satisfied, the condition on the rank of the direct effective channel is immediately satisfied as a consequence, since the MIMO channel matrices considered here are full-rank with elements randomly picked up from a continuous distribution. This is not verified in general for the interference alignment schemes constructed over time-extensions, since in this case the channel matrices have a diagonal structure.

Both the iterative algorithms presented alternate between the original and the reciprocal networks in order to progressively attain the alignment of the interference. At each step the algorithms update only the interference suppression filters in the considered network and then the communication direction is inverted. In the next step the interference suppression filters used in the previous iteration become the new precoding filters and the receive filters are set as the transmit filters used in the step before. The algorithms continue until convergence is achieved.

The first algorithm presented and indicated here as “Min_WLI” achieves perfect interference alignment by iteratively reducing the weighted leakage interference (WLI), defined as the sum, over all the receivers, of the powers of the interference experienced by each receiver, weighted on their transmit

power when they have the role of transmitter in the reciprocal network [3]:

$$\text{WLI} = \sum_{k=1}^K \sum_{j=1, j \neq k}^K \frac{\overleftarrow{P}_k}{d_k} \frac{P_j}{d_j} \text{Tr} \left[\mathbf{U}_k^H \mathbf{H}_{kj} \mathbf{V}_j \mathbf{V}_j^H \mathbf{H}_{kj}^H \mathbf{U}_k \right]. \quad (3.68)$$

It is a measure of the quality of the alignment of interference at all the receivers in the network and ideally it should be zero.

The weighted leakage interference is iteratively reducing by choosing, at each receiver within each network, the interference suppression filters as to minimize the remaining interference in the desired signal subspace after the filters are applied. The d_i columns of the i th receiver interference suppression matrix are therefore set to be the eigenvectors corresponding to the d_i smallest eigenvalues of the interference covariance matrix \mathbf{Q}_i :

$$\mathbf{U}_{i[\star k]} = \nu_k[\mathbf{Q}_i] \quad \forall k = 1, \dots, d_i \quad (3.69)$$

where $\nu_k[\mathbf{A}]$ denotes the eigenvector corresponding to the k th smallest eigenvalues of the matrix \mathbf{A} .

In this way the algorithm finds an interference-free subspace which is designed for the desired signal. Since at each step the value of WLI is monotonically reduced the convergence of the algorithm is guaranteed. Furthermore choosing an arbitrarily small value of WLI for which the algorithm stops, we can enhance the quality of the interference alignment scheme at the price of a higher number of iterations. The iterative procedure of the algorithm is summarized as the following:

Min_WLI

1. Start with arbitrary precoding matrices $\mathbf{V}_i \forall i = 1, \dots, K$ so that the column vectors of each precoding matrices are orthonormal to each other.
2. Compute the interference covariance matrices \mathbf{Q}_i at all the receivers $\forall i = 1, \dots, K$ using Equation (3.63).

3. Calculate the interference suppression matrices $\mathbf{U}_i \forall i = 1, \dots, K$ using Equation (3.69).
4. Reverse the communication direction, passing to the reciprocal network, and set $\overleftarrow{\mathbf{V}}_i = \mathbf{U}_i \forall i = 1, \dots, K$.
5. In the reciprocal network calculate the interference covariance matrices $\overleftarrow{\mathbf{Q}}_i$ at all the receivers $\forall i = 1, \dots, K$.
6. Reverse the communication direction, returning to the original network, and set $\mathbf{V}_i = \overleftarrow{\mathbf{U}}_i \forall i = 1, \dots, K$.
7. Continue till convergence.

The second algorithm introduced is denoted with “Max.SINR”. Before presenting this algorithm we remind that each of the columns of the precoding matrix \mathbf{V}_i represents the beamforming vector of each of the d_i streams transmitted by the i th transmitter with power $\frac{P_i}{d_i}$. Similarly, at the receiver side, the columns of the matrix \mathbf{U}_i^H are the combining vectors of the corresponding data streams.

Instead of minimizing the leakage interference in the signal subspace, this algorithm maximizes the SINR of the single data streams, allowing for some remaining interference in the signal subspace. The column vectors of the receiving interference suppression matrix that maximizes the SINR of the l th streams of the k th receiver are given by:

$$\mathbf{U}_{i[\star k]} = \frac{(\mathbf{B}_{ik})^{-1} \mathbf{H}_{ii} \mathbf{V}_{i[\star k]}}{\|(\mathbf{B}_{ik})^{-1} \mathbf{H}_{ii} \mathbf{V}_{i[\star k]}\|} \quad \forall i = 1, \dots, K, \quad \forall k = 1, \dots, d_i. \quad (3.70)$$

The iterative procedure is summarized as the following:

Max_SINR

1. Start with arbitrary precoding matrices $\mathbf{V}_i \forall i = 1, \dots, K$ so that the column vectors of each precoding matrices are linearly independent to each other.

2. Compute the interference plus noise covariance matrices \mathbf{B}_{ik} for the k th stream of the i th receiver, $\forall i = 1, \dots, K, \forall k = 1, \dots, K$.
3. Calculate each of the d_i columns of the interference suppression matrices $\mathbf{U}_{i[\star k]}$ with Equation (3.70), $\forall i = 1, \dots, K, \forall k = 1, \dots, d_i$.
4. Reverse the communication direction, passing to the reciprocal network, and set $\overleftarrow{\mathbf{V}}_i = \mathbf{U}_i \forall i = 1, \dots, K$
5. In the reciprocal network compute the interference plus noise covariance matrices $\overleftarrow{\mathbf{B}}_{ik}$ similarly to 2.
6. In the reciprocal network calculate each column of the interference suppression matrices $\overleftarrow{\mathbf{U}}_{i[\star k]}$ similarly to 3.
7. Reverse the communication direction, returning to the original network, and set $\mathbf{V}_i = \overleftarrow{\mathbf{U}}_i \forall i = 1, \dots, K$.
8. Continue till convergence.

Further details on the presented algorithms and the omitted proofs can be found in the original paper [3].

Both the algorithms start the iteration procedure with arbitrary precoding matrices. However there is a slightly difference in the initializations of them in the two cases. While the `Min_WLI` algorithm assumes that the columns of each beamforming matrix are orthonormal to each other, in the `Max_SINR` algorithm the columns are assumed to be only linearly independent.

3.4 Feasibility of IA

An interference alignment scheme is said to be feasible with multiplexing gains (d_1, d_2, \dots, d_K) if and only if there exist $N_T \times d_i$ precoding matrices \mathbf{V}_i and $N_R \times d_i$ interference suppression matrices \mathbf{U}_i such that they verify the

following interference alignment conditions, for $i = 1, \dots, K$:

$$\begin{aligned} \mathbf{U}_i^H \mathbf{H}_{ij} \mathbf{V}_j &= 0 \quad \forall j \neq i \\ \text{rank}(\mathbf{U}_i^H \mathbf{H}_{ii} \mathbf{V}_i) &= d_i. \end{aligned} \quad (3.71)$$

Determine the feasibility of an interference alignment scheme is a problem that has been addressed in different ways. Particularly, [6] explains the correct way to count the number of equations and variables in MIMO interference alignment systems. The scope of the paper is to divide them into two categories which are called proper and improper systems. An intuitive understanding that proper systems are feasible while improper are not is finally given.

Moreover, in [3] the iterative algorithm presented in the previous section is used to check numerically the theoretical feasibility of an interference alignment system with a given number of streams per user. An interference alignment scheme is feasible when the interference power in the desired signal subspace is zero so that, at receiver i it must be verified that $\sum_{k=1}^{d(i)} \lambda_k[\mathbf{Q}_i] = 0$ for perfect interference alignment, where $\lambda_k[\mathbf{A}]$ denotes the k th smallest eigenvalue of \mathbf{A} and $\lambda_k[\mathbf{Q}_i]$ represents the interference power in the desired signal space.

The percentage of interference in the desired signal subspace at receiver i is therefore given by [3]

$$p_i = \frac{\sum_{k=1}^{d(i)} \lambda_k[\mathbf{Q}_i]}{\text{Tr}[\mathbf{Q}_i]} \quad (3.72)$$

and the fraction equals to zero when the interference alignment is feasible.

Interference Alignment with Noisy CSIT

In this chapter we present the model that we have used in this work in order to characterize the impact on the performance when only noisy channel state information are available at the transmitter or at the receiver side.

In the previous chapter we have shown the working principles of the new technique called interference alignment, a combination of precoding at the transmitter and interference suppression at the receiver that permits to achieve the optimal multiplexing gain in wireless interference networks. This, however, comes at the price that each node must have complete and accurate channel state information at each instant. In other words all the nodes must perfectly know all the channel matrices between all the transmitters and the receivers for all the channel uses.

It is often reasonable to assume that the receivers have a good approximation of the instantaneous channel knowledge gained, for instance, by estimation of the wireless medium condition through the use of pilot symbols inserted in the information signal and known both by the transmitter and the

receiver. This is true for instance in the new generation of cellular systems, 3G and 4G [36], [37], and in numerous standards for broadband wireless networks, within the 802.16 family.

The knowledge of the channel matrices at the transmitters is attested to considerably improve the performances of the communication [23], [25] and it is a necessary condition to implement transmit beamforming techniques, such as interference alignment. As nothing comes for free, many difficulties have to be faced in order of taking advantage of the enhancement of the performances promised by having channel state information available at the transmitter side.

4.1 CSIT

Since our goal is a study on interference alignment we will not deal with many serious practical problems, such as the delay for obtaining feedback, and other difficulties that can severely affect the performances of feedback techniques, such as the mobile speed which is influenced also by the carrier frequency used for the transmission, or the channel Doppler spread. The effects of outdated channel state information, feedback delay and error have been studied for various precoding techniques in 3GPP and are proven to have a serious impact on the performances [35].

The CSIT is usually modelled as an estimate of the channel mean together with the estimation error covariance, both dependent on a parameter which is in turn dependent on the time delay when of the channel observation and the Doppler spread. This parameter then indicates the quality of the CSIT, and permits to study the various situations ranging from perfect CSIT to pure statistics [23].

Since in order to implement an interference alignment scheme all the transmitters and the receivers must have the knowledge of all the channel matrices at all instants, in our analysis we do not use this modelling but

instead we utilize directly the channel realizations. Therefore the ideal case of perfect channel state information knowledge here means that all the nodes know the realizations of all the channels between all the transmitters and the receivers, at each instant.

In practice, the amount of feedback that the transmitter can communicate to its receiver is usually limited, mainly by the coherence time of the channel but also by the resolution of the quantizer and the number of parameters being quantized. The first idea that comes to mind when dealing with limited feedback is quantizing the channel matrices with a resolution that depends on the constraints stated above. Beamforming based on limited feedback has been intensively studied for single user MIMO communications and a large number of techniques has been presented [29], [30].

Some of those include the possibility for the transmitter to choose among difference signalling techniques or improving the quantized information needed to the transmitter, for instance communicating only the quantized version of the singular values instead of all the channel matrix. More complex techniques include random vector quantization (RVQ) and Grassmanian quantization of each user's channel [29], in which the precoding matrices are picked up between a random selection of possible choices, so that the distance between the spaces spanned by the precoding matrices is maximized. A recent work combines Grassmanian quantization and interference alignment showing that, at high SNR, interference alignment still remains the optimal way to achieve the maximal multiplexing gain in interference networks with single antenna nodes, even with a limited rate feedback channel [13].

Here we use the name of a matrix without subscripts to indicate the set of all the matrices of the same type. For instance, we indicate with \mathbf{H} the shorten notation for the set of all the channel matrices $\mathbf{H}_{ij} \forall i, j$, and similarly for \mathbf{U} and \mathbf{V} to indicate the set of the \mathbf{V}_i and $\mathbf{U}_i \forall i$, respectively. With this notation, we stress that perfect CSIT is equivalent to the perfect knowledge of \mathbf{H} at all the transmitters and the receivers.

4.2 System Model

To investigate the impact of the noisy channel state information on the performance of interference alignment schemes considered, following [4], we introduce the channel measurement error \mathbf{E} which is due to use of outdated channel matrices, estimation error and time variation of the channel. The noisy estimates of the channel matrices are therefore given by

$$\tilde{\mathbf{H}} = \mathbf{H} + \mathbf{E} \quad (4.1)$$

and we assume that all the nodes undergo the same estimation error. \mathbf{E} is modelled as a complex Gaussian circularly symmetric random matrix with i.i.d. elements of variance σ_E^2 . The precoding matrices and the interference suppression matrices computed using the noisy estimates of the channel matrices $\tilde{\mathbf{H}}$ are indicated by $\tilde{\mathbf{V}}$ and $\tilde{\mathbf{U}}$. Note that when symbol extensions are used, and the channel matrices have a diagonal structure, then the channel error matrix \mathbf{E} is diagonal as well.

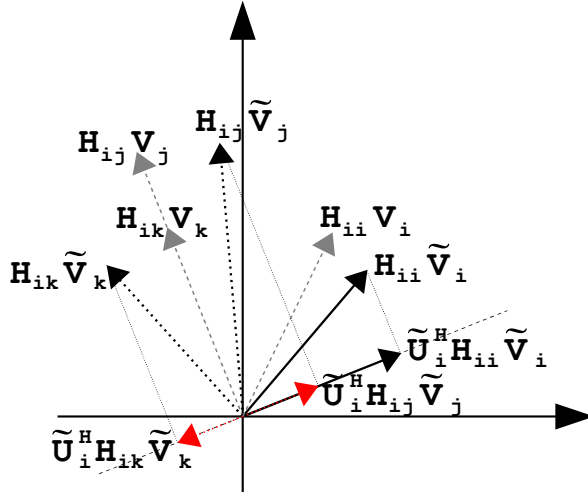

Figure 4.1: Noisy $\tilde{\mathbf{V}}$ and $\tilde{\mathbf{U}}$ cause some interference remaining in the desired signal subspace.

The situation at receiver i is depicted in Figure 4.1 assuming there are two other transmitters j and k in the network. We highlight that the interference

vectors $\mathbf{H}_{ij}\tilde{\mathbf{V}}_j$ and $\mathbf{H}_{ik}\tilde{\mathbf{V}}_k$ are now not aligned and therefore it is not possible to completely suppress all the interference from the desired signal subspace since $\tilde{\mathbf{U}}_i^H\mathbf{H}_{ij}\tilde{\mathbf{V}}_j \neq 0$ and $\tilde{\mathbf{U}}_i^H\mathbf{H}_{ik}\tilde{\mathbf{V}}_k \neq 0$.

The receive signal of user i after interference suppression is thus given by

$$\begin{aligned} \mathbf{y}_i &= \tilde{\mathbf{U}}_i^H\mathbf{H}_{ii}\tilde{\mathbf{V}}_i\mathbf{x}_i + \sum_{j=1, j \neq i}^K \tilde{\mathbf{U}}_i^H\mathbf{H}_{ij}\tilde{\mathbf{V}}_j\mathbf{x}_j + \tilde{\mathbf{U}}_i^H\mathbf{n}_i \\ &= \tilde{\mathbf{U}}_i^H(\tilde{\mathbf{H}}_{ii} + \mathbf{E}_{ii})\tilde{\mathbf{V}}_i\mathbf{x}_i + \sum_{j=1, j \neq i}^K \tilde{\mathbf{U}}_i^H(\tilde{\mathbf{H}}_{ij} + \mathbf{E}_{ij})\tilde{\mathbf{V}}_j\mathbf{x}_j + \tilde{\mathbf{U}}_i^H\mathbf{n}_i \quad (4.2) \end{aligned}$$

and introducing the effective noise vector $\tilde{\mathbf{n}}_i$ and the $d_i \times d_j$ effective error matrices $\tilde{\mathbf{E}}_{ij} = \tilde{\mathbf{U}}_i^H\mathbf{E}_{ij}\tilde{\mathbf{V}}_j$ and using the fact that $\tilde{\mathbf{U}}_i^H\tilde{\mathbf{H}}_{ij}\tilde{\mathbf{V}}_j = 0 \forall i \neq j$ we can further write:

$$\begin{aligned} \mathbf{y}_i &= (\tilde{\mathbf{U}}_i^H\tilde{\mathbf{H}}_{ii}\tilde{\mathbf{V}}_i + \tilde{\mathbf{E}}_{ii})\mathbf{x}_i + \sum_{j=1, j \neq i}^K \tilde{\mathbf{E}}_{ij}\mathbf{x}_j + \tilde{\mathbf{n}}_i \\ &= (\tilde{\tilde{\mathbf{H}}}_{ii} + \tilde{\mathbf{E}}_{ii})\mathbf{x}_i + \sum_{j=1, j \neq i}^K \tilde{\mathbf{E}}_{ij}\mathbf{x}_j + \tilde{\mathbf{n}}_i \quad (4.3) \end{aligned}$$

where $\tilde{\tilde{\mathbf{H}}}_{ii} = \tilde{\mathbf{U}}_i^H\tilde{\mathbf{H}}_{ii}\tilde{\mathbf{V}}_i$ is the $d_i \times d_i$ effective estimated channel matrix at the i th receiver.

4.2.1 Perfect and Noisy CSIR

Throughout our work we have considered two possible scenarios when noisy channel state information are available at the transmitters (CSIR). Clearly, since the transmitters have only noisy channel state information, in both cases the beamforming matrices are calculated from the noisy versions of the channel matrices, however in the first case we have assumed that the receivers can track the channel matrices perfectly (Perfect CSIR) while in the second case we have assumed that also the receivers have only noisy channel state information available (Noisy CSIR).

The first scenario can be a case in which the receivers manage to track the channel matrices perfectly through, for instance, channel estimation using

pilot symbols known at both the side of the communication and the channel state information at the transmitter are noisy because the feedback channel is in a bad condition. In this situation, the beamforming matrices are calculated using the noisy estimates while the interference suppression matrices are calculated using $\tilde{\mathbf{V}}$ and the perfect channels \mathbf{H} . The zero-forcing equalizer is also calculated using the perfect channel matrices \mathbf{H} .

The second scenario, instead, can be caused by imperfect channel estimation at the receivers which in turn communicate the noisy channels at the transmitters. For the sake of simplicity we consider in this case that the same noisy channel matrices $\tilde{\mathbf{H}}$ are used by the transmitters and receivers. In this situation the beamforming matrices, the interference suppression matrices and the zero-forcing equalizers are computed using the noisy channel estimates.

Our performed simulations have shown that the performances in the first case are slightly better than in the second case, however in order make the discussion easier, in Chapter 5 we will show the results only for the second scenario (Noisy CSIR), when all the parameters of the system at both sides of the communication are affected by noisy channel state information.

Simulation Results

In order to compare the performances of the interference alignment systems presented in the previous sections, Monte Carlo simulations have been performed. The general model of Section 2.5 is specified here for the two considered scenario of SISO and MIMO systems.

5.1 System model and practical implementation

The model that we have implemented to carry out our simulations is depicted in Figure 5.1 for the transmitter i and its desired receiver, also denoted by i . Given the large number of matrix inversions necessary to perform in order to compute the transmit and receive filters, the chosen simulation environment is Matlab because of its native feature to operate with matrices. On the other hand we have paid the price of a slower execution of the cycles present in the iterative algorithms. We now explain in detail each component of our simulation model.

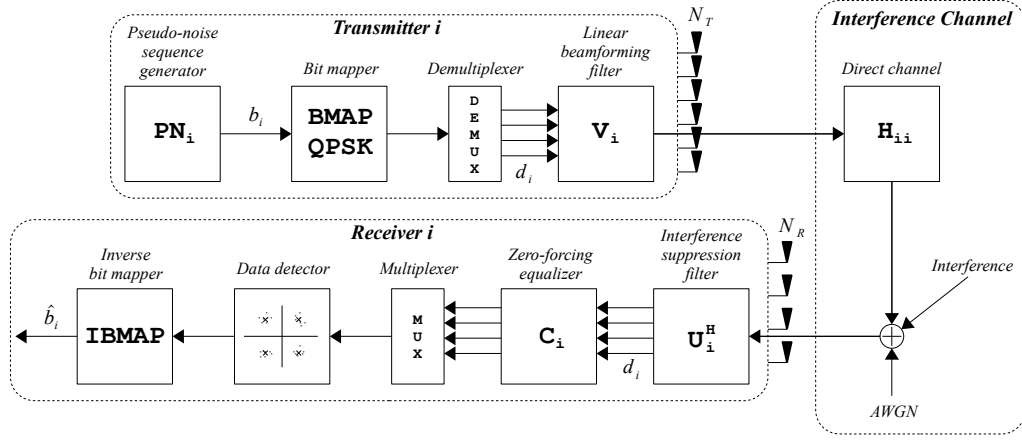

Figure 5.1: The model implemented to carry out our simulations.

To ensure the randomness of the transmitted symbols, the sequence of information bits b_i at the input of the bit mapper (BMAP) is generated as a pseudo-noise (PN) sequence. In our simulations we use maximal-length (ML) sequence generated recursively as shown in [18, Appendix 3.A] with period $L = 2^{20} - 1 = 1048575$ and different initial conditions for all the users in the network.

The bit mapper maps the information bits in sequences of symbols and the modulation used here is the quadrature phase shift keying (QPSK). In order to highlight the performance of the interference alignment schemes considered we assume that neither coding nor interleaving are performed on the information data.

The symbols sequence is then demultiplexed in d_i information streams which are in turn passed as input to the linear precoder and beamformed with the matrix \mathbf{V}_i to obtain the signal to be transmitted over the channel. In the following of this chapter we will give the explicit expressions used in the simulations for the closed form expressions of the beamforming matrices introduced in general in Section 3. The columns of \mathbf{V}_i are normalized in order to satisfy the power constraint of each transmitter. In all the simulations involving the iterative algorithms, the normalization of the beamforming matrices is accomplished at each iteration, before switching to

the reciprocal network.

Note that, since the multiplexer preserves the independence of the input symbols [19], for the purpose of the simulation the use of a multiplexer has no relevance and is equivalent of having d_i different random bit generators followed by the same number of QPSK modulators.

The transmitted power is assumed to be equal for all the transmitters and, in the case of transmission of multiple streams, equally distributed between the various streams.

The channel is assumed Rayleigh flat-fading as described in Section 2.4 and a new realization is generated for each channel use. The desired signal undergoes interference from the other transmitters in the network as well as AWGN.

The received signal is then processed with the interference suppression matrix \mathbf{U}_i and filtered with the zero-forcing equalizer defined in Equation (2.6) which has the task of nullifying the effects of the effective channel given by the cascade of precoder, channel and interference suppression filter. Different interference suppression matrices and zero-forcing equalizers will lead to different amplifications of the noise at the decision point.

The interference suppression matrices are computed iteratively for the distributed algorithms shown in Section 3.3.2. When the closed form solutions are used for the beamforming matrices, the receive filters are computed using (3.2). In our simulations the null space of the received interference is computed using the Matlab `null(.)` function which in turn resorts to the `svd(.)` function which gives the singular value decomposition (SVD) of the input matrix.

We briefly explain how the null space of a matrix is calculated. Let $[\mathbf{U}_A, \mathbf{S}_A, \mathbf{V}_A] = \text{svd}(\mathbf{A})$ be the singular value decomposition of \mathbf{A} , where \mathbf{U}_A and \mathbf{V}_A are unitary matrices and \mathbf{S}_A is a diagonal matrix of the same size of \mathbf{A} whose elements on the diagonal are called singular values. Then the

columns of \mathbf{V}_A corresponding to the zero singular values form an orthonormal basis of the null space of \mathbf{A} . Specifically, in Matlab the singular values are considered zero when are less than an arbitrary small tolerance.

The obtained replicas of the transmitted streams are then multiplexed in a single stream and then passed to the data detector, implemented as a threshold detector with thresholds determined by the QPSK constellation used in our simulations. The subsequent inverse bit mapper (IBMAP) performs the inverse function of the bit mapper, translating detected symbols into the recovered information bits \hat{b}_i .

Comparing the original transmitted bits and the detected bits at the receiver, the bit error rate (BER) for user i is then computed as:

$$\text{BER}_i = \frac{\text{number of bits received with errors}}{\text{total number of received bits}}. \quad (5.1)$$

5.2 Numerical computation of the feasibility of IA schemes

It is possible to investigate numerically the feasibility of an interference alignment scheme, for a given number of transmit and receive antennas, by plotting the percentage of interference in the desired signal subspace versus the total number of transmitted streams in the network. An interference alignment scheme is feasible when the interference in the desired signal subspace is zero, within numerical errors. We recall here Equation (3.72) taken from [3], that shows how to calculate the interference percentage at node i :

$$p_i = \frac{\sum_{k=1}^{d(i)} \lambda_k[\mathbf{Q}_i]}{\text{Tr}[\mathbf{Q}_i]}.$$

Note that the value of p_i does not depend on the transmitted power, since it is normalized by the trace of \mathbf{Q}_i . However, in order to give consistent results, the calculated values of the interference are averaged over a large number of channel realizations and also over the values of SNR of interest in our simulations.

Once we calculate the percentage of interference p_i at each node i , $\forall i = 1, \dots, K$, two criteria are used to get a single value that summarizes the value of the interference for the specific scheme analyzed. The first is to average between the values of all the p_i calculated, and the second is to take the maximum value. The results using the two criteria are given in Figure 5.2 for networks comprised of three and four users with variable number of antennas at each node.

(a) Three nodes: average of the p_i .(b) Three nodes: maximum value of the p_i .(c) Four nodes: average of the p_i .(d) Four nodes: maximum value of the p_i .

Figure 5.2: Percentage of interference in desired signal subspace in the three users and four users MIMO-IC.

The above Figure 5.2(a) and Figure 5.2(b) suggest that a maximum of four streams can be transmitted without interference in a three users interference channel when the nodes are equipped with three antennas and a total of six streams can be transmitted in a three users network when four antennas are available at each node. Note that for the three users interference

channel with two antennas at each node a maximum of three streams can be transmitted without interference.

We then infer from Figure 5.2(c) and Figure 5.2(d) that in order to transmit a total of eight streams in a four users interference network, the nodes must be equipped with five antennas. If four antennas are available at each node instead the maximum number of interference free streams achievable is six.

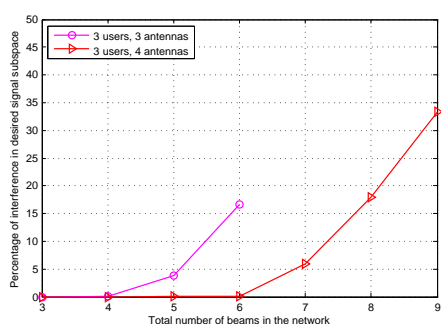
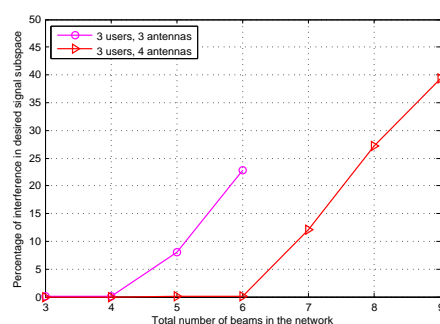
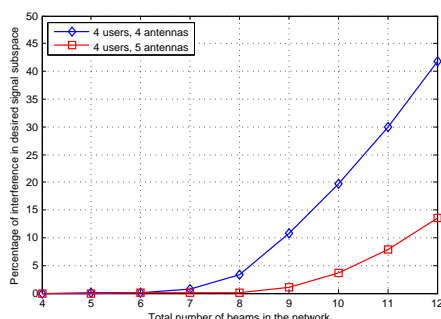
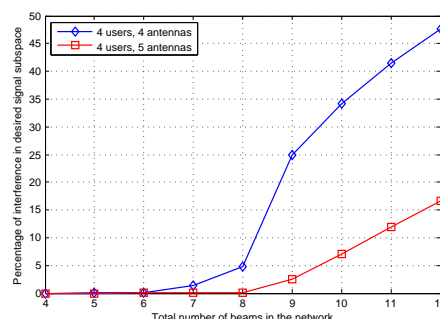
5.3 Simulation results with perfect CSI

Using the model introduced in the previous sections, we now show the results of our simulations. Simulations show that the simulated bit error rates are different for each nodes in the SISO-IC and very similar in the MIMO-IC for the reasons that we will explain later. Hence, in our graphs we plot the BER of each user in the SISO-IC and the average of all the BERs in the MIMO-IC.

To simulate the performance of the SISO-IC we use in our simulations the efficient beamforming design explained in Section 3.2.2 since it is equivalent to the original one presented in 3.2.1 while having less redundancy in the definition of the transmit matrices. We indicate with “Node i ” the transmitter using the beamforming matrix \mathbf{V}_i .

For the MIMO-IC, as stated in Section 3.3, closed form solutions of the beamforming matrices exist only for the three user interference channel. When the network is comprised with more than three users, it is necessary to resort to iterative algorithms in order to find the transmit and the receive filters.

We remind that symbol extensions are necessary in order to construct an interference alignment scheme in the SISO-IC but not in the MIMO-IC.

5.3.1 SISO-IC: three nodes single antenna with $n^* = 0$

For the three users interference channel with single antenna nodes, a total of 9 channel matrices $\mathbf{H}_{ij}, \forall i, j = 1, 2, 3$ are generated at each channel use. Table 5.1 summarizes the characteristics of the three users SISO-IC and shows the values assumed by the parameters of the system and the dimensionality of the matrices when $n^* = 0$. Note that $n^* = 0$ of the efficient beamforming design is equivalent to $n = 1$ in the original presented scheme. The simulated bit error probabilities for each user are given in Figure 5.3.

Alignment constructed over symbol extensions of the original channel			
Number of nodes:	$K = 3$	\implies	$N = 1$
Arbitrary nonnegative integer:	$n^* = 0$		
Dimensionality of the space:	$M = 3$		
Degrees of freedom of the nodes:	$d_1 = 2$	$d_2 = 1$	$d_3 = 1$
Achieved network multiplexing gain:	$r = \frac{4}{3}$		
Dimensionality of the diagonal matrices:	$\mathbf{H}_{ij} \quad \forall i, j$	3×3	
	$\mathbf{V}_1, \mathbf{U}_1$	3×2	
	$\mathbf{V}_2, \mathbf{U}_2$	3×1	
	$\mathbf{V}_3, \mathbf{U}_3$	3×1	

Table 5.1: SISO-IC: three nodes single antenna with $n^* = 0$.

We stress that the number of streams transmitted is equal to two for the first node and equal to one for the other two nodes and the transmitted power is the same at all the transmitters and equally divided between the transmitted streams. As a consequence each of the two streams transmitted by the first user have half the power of the single stream transmitted by the each of the other two users.

Two transformations $\widehat{\mathbf{T}}_j^{[k]}$ are generated at each channel use:

$$\begin{aligned}\widehat{\mathbf{T}}_3^{[2]} &= (\mathbf{H}_{21})^{-1} \mathbf{H}_{23} \\ \widehat{\mathbf{T}}_2^{[3]} &= (\mathbf{H}_{31})^{-1} \mathbf{H}_{32} (\mathbf{H}_{12})^{-1} \mathbf{H}_{13}.\end{aligned}$$

The beamforming matrices assume the form:

$$\begin{aligned}\mathbf{V}_1 &= \begin{bmatrix} \mathbf{w}, & \mathbf{H}_{21}(\mathbf{H}_{23})^{-1}(\mathbf{H}_{31})^{-1}\mathbf{H}_{32}(\mathbf{H}_{12})^{-1}\mathbf{H}_{13}\mathbf{w} \end{bmatrix} \\ \mathbf{V}_3 &= \begin{bmatrix} \mathbf{H}_{21}(\mathbf{H}_{23})^{-1}\mathbf{w} \end{bmatrix} \\ \mathbf{V}_2 &= \begin{bmatrix} (\mathbf{H}_{12})^{-1}\mathbf{H}_{13}\mathbf{H}_{21}(\mathbf{H}_{23})^{-1}\mathbf{w} \end{bmatrix}\end{aligned}$$

and the beamforming matrices are calculated using:

$$\begin{aligned}\mathbf{U}_1 &= \text{null}\left(\begin{bmatrix} \mathbf{H}_{13}\mathbf{V}_3 \end{bmatrix}^{\text{H}}\right) \\ \mathbf{U}_2 &= \text{null}\left(\begin{bmatrix} \mathbf{H}_{21}\mathbf{V}_1 \end{bmatrix}^{\text{H}}\right) \\ \mathbf{U}_3 &= \text{null}\left(\begin{bmatrix} \mathbf{H}_{31}\mathbf{V}_1 \end{bmatrix}^{\text{H}}\right).\end{aligned}$$

The main point to note in Figure 5.3 is that, as anticipated before, the simulated bit error rates are different for the three users in the network. We focus our analysis on the second and the third nodes since they both send one stream with the same transmit power but they undergo different bit error rates.

During our simulations we have checked by inspection in Matlab the quality of the interference alignment scheme and we noticed that the suppression of the interference effectively works that is $\mathbf{U}_i^{\text{H}}\mathbf{H}_{ij}\mathbf{V}_j = 0$ within numerical errors, $\forall j \neq i$. Hence we cannot attribute this difference to different qualities of the alignment of interference.

Furthermore, the channel matrices are diagonal and the elements on the diagonal are drawn from a continuous distribution and have zero mean and unitary variances. The transmit precoding filters are normalized to have unitary power equally distributed between the transmitted streams at each node and the Matlab `null(·)` function used in our simulations in order to find the interference suppression filters always return matrices whose columns have unitary power.

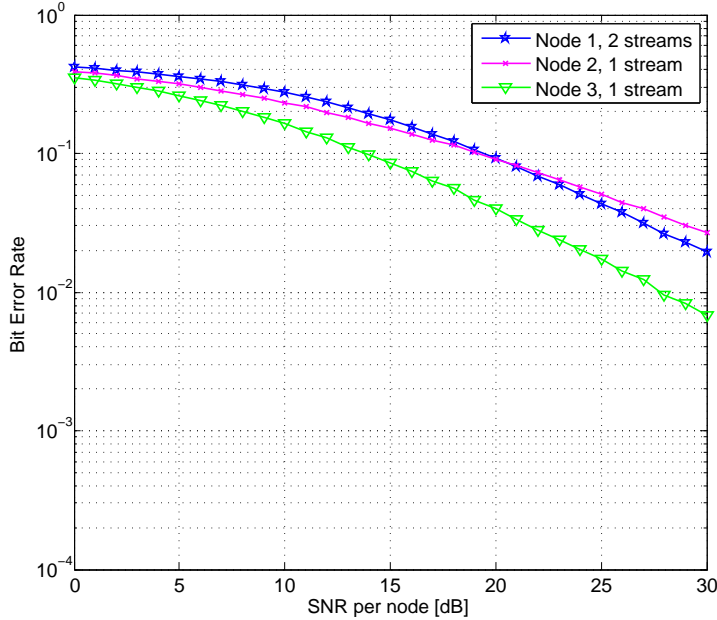

Figure 5.3: SISO-IC: three nodes single antenna with $n^* = 0$.

It is known from the theory of channel equalization [18] that different values of the power of the zero-forcing equalizer can lead in fact to different amplification of the noise at the decision point, causing therefore different bit error rates. This has led us to consider more in depth the zero-forcing equalizer defined in Equation (2.6) that for the second and the third node simply reduces to a single complex number since $d_2 = d_3 = 1$.

We have noticed, by inspection in Matlab, that the power of the zero-forcing equalizer of the third node is less than the power of the zero-forcing equalizer of the node 2 $\|(\mathbf{U}_3^H \mathbf{H}_{33} \mathbf{V}_3)^{-1}\|^2 > \|(\mathbf{U}_2^H \mathbf{H}_{22} \mathbf{V}_2)^{-1}\|^2$ with probability around 0.66.

After a more careful insight we have noticed, again by inspection, that this is caused because $\|(\mathbf{U}_3^H \mathbf{V}_3)^{-1}\|^2 > \|(\mathbf{U}_2^H \mathbf{V}_2)^{-1}\|^2$ for almost the same probability (differences are justified by the random nature of the direct channel matrices \mathbf{H}_{33} and \mathbf{H}_{22}) despite that the vectors taken individually have unitary power.

Giving a rigorous mathematical proof of what we have pointed out is not easy at all. Even if the channel matrices are diagonal, their diagonal elements are drawn independently from a continuous distribution. In addition the interference suppression matrices are calculated as the null space of the product of random diagonal channel matrices and their inverses and the beamforming matrices as well are given by the product of channel matrices and their inverses.

In our opinion the reason might be attributable to the specific beamforming and interference suppression matrices used and, in the light of [7], we do not exclude that the reason might be sought only by carefully examining the relation between the subspaces spanned by them. However finding a rigorous justification of what we have noticed above goes beyond the scope of this work.

5.3.2 MIMO-IC: three nodes with two antennas sending one stream

We specify in Table 5.2 the values of the system parameters for an interference network comprised of three pairs of transmitter-receiver when each node is equipped with two antennas. We also rewrite explicitly the closed form expressions of the beamforming matrices. Figure 5.4 shows the performances of the various beamforming design methods previously described.

The distributed `Min_WLI` algorithm permits to find precoding matrices that performs in the same manner as the precoding matrices calculated using the exact closed form expressions. The `Max_SINR` algorithm, maximizing the desired stream for each receiver, outperforms the others between five and eight dB. In the three users two antennas MIMO-IC, within the SNR range of analysis, an increase of the transmit power always causes an decrease in the BER. In other words the power of interference does not increase so that to cause a degradation of the overall performance of the system.

Number of nodes:	$K = 3$		
Number of antennas per node:	$M = 2$		
Degrees of freedom of the nodes:	$d_1 = 1$	$d_2 = 1$	$d_3 = 1$
Achieved network multiplexing gain:	$r = 3$		
Dimensionality of the matrices:	$\mathbf{H}_{ij} \quad \forall i, j$	2×2	
	$\mathbf{V}_1, \mathbf{U}_1$	2×1	
	$\mathbf{V}_2, \mathbf{U}_2$	2×1	
	$\mathbf{V}_3, \mathbf{U}_3$	2×1	
Closed form expressions of the beamforming matrices:			
	$\mathbf{e}_1 = \text{eig} \left[(\mathbf{H}_{31})^{-1} \mathbf{H}_{32} (\mathbf{H}_{12})^{-1} \mathbf{H}_{13} (\mathbf{H}_{23})^{-1} \mathbf{H}_{21} \right]$		
	$\mathbf{V}_1 = \mathbf{e}_1$		
	$\mathbf{V}_2 = (\mathbf{H}_{32})^{-1} \mathbf{H}_{31} \mathbf{V}_1$		
	$\mathbf{V}_3 = (\mathbf{H}_{23})^{-1} \mathbf{H}_{21} \mathbf{V}_1$		

Table 5.2: MIMO-IC: three nodes with two antennas sending one stream. System parameters and explicit expressions of the beamforming matrices.

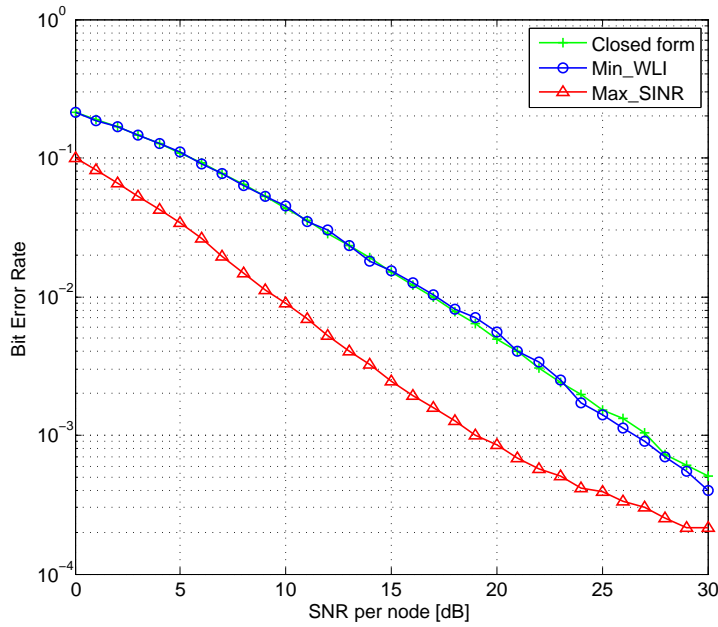

Figure 5.4: MIMO-IC: three nodes with two antennas sending one stream.

5.3.3 MIMO-IC: three nodes with four antennas sending two streams

The relations of Table 5.3 are valid in a three users interference channel when the nodes are equipped with four antennas. The simulated bit error rates for the beamforming design techniques are then given in Figure 5.5.

Number of nodes:	$K = 3$		
Number of antennas per node:	$M = 4$		
Degrees of freedom of the nodes:	$d_1 = 2$	$d_2 = 2$	$d_3 = 2$
Achieved network multiplexing gain:	$r = 6$		
Dimensionality of the matrices:	$\mathbf{H}_{ij} \quad \forall i, j$	4×4	
	$\mathbf{V}_1, \mathbf{U}_1$	4×2	
	$\mathbf{V}_2, \mathbf{U}_2$	4×2	
	$\mathbf{V}_3, \mathbf{U}_3$	4×2	
Closed form expressions of the beamforming matrices:			
	$\begin{bmatrix} \mathbf{e}_1, & \mathbf{e}_2 \end{bmatrix} = \text{eig} \left[(\mathbf{H}_{31})^{-1} \mathbf{H}_{32} (\mathbf{H}_{12})^{-1} \mathbf{H}_{13} (\mathbf{H}_{23})^{-1} \mathbf{H}_{21} \right]$		
	$\mathbf{V}_1 = \begin{bmatrix} \mathbf{e}_1, & \mathbf{e}_2 \end{bmatrix}$		
	$\mathbf{V}_2 = (\mathbf{H}_{32})^{-1} \mathbf{H}_{31} \mathbf{V}_1$		
	$\mathbf{V}_3 = (\mathbf{H}_{23})^{-1} \mathbf{H}_{21} \mathbf{V}_1$		

Table 5.3: MIMO-IC: three nodes with four antennas sending two streams. System parameters and explicit expressions of the beamforming matrices.

Compared to the previous case, when the nodes are equipped with four antennas we note an overall degradation in the performances for all the beamforming methods considered. The bit error rates are in general higher compared to as before, since we are using the more antennas available only to double our transmission rates and we are not using the additional degree of freedom available to enhance the diversity of the communication. It is well known the fundamental trade-off [27] between diversity and multiplexing in multiple antenna channels. We would expect to obtain lower bit error rates by sending two replica of the same data stream instead of two independent and using a suitable receive filter, for instance employing a minimum mean square error (MMSE) receiver.

Here, we note that the closed-form expressions of the beamforming design give higher bit error rates compared to the `Min_WLI` and this difference increases as the transmit power of the nodes increases. Again, the `Max_SINR` highly outperforms both the other algorithms, as its aim is to maximize the SINR at each receiver at the price of permitting some interference leakage in the desired signal subspaces.

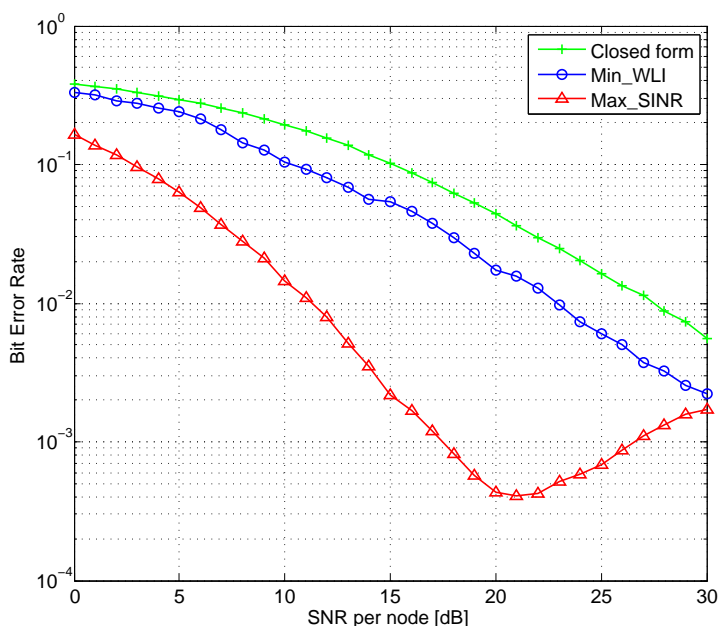

Figure 5.5: MIMO-IC: three nodes with four antennas sending two streams.

The curve of the bit error rate of the `Max_SINR` algorithm shows an interesting trend. Before the SNR at each node reaches twenty dB the bit error rate is constantly reduced, which indicates that for high transmit powers the interference in the desired signal subspace becomes progressively predominant over the desired signal, causing a degradation of the performance.

Since the aim of this distributed algorithm is not to reduce the total interference experienced by the nodes in the network, this result does not disagree with Figure 5.2(a) and Figure 5.2(b) that show that eight degrees of freedom are achievable with four antennas nodes in the three users interference

channel. In fact, from Figure 5.5, we also note that the other distributed algorithm `Min_WLI` leads to a constant reduction of the bit error rate as the transmit power increases.

5.3.4 MIMO-IC: four nodes with four or five antennas sending two streams

When the number of users in the network is more than three, no closed form solutions of the beamforming matrices are known at the present and we must resort to the iterative algorithms to find the transmit filters. We consider two possible scenarios of the four user interference network: nodes equipped with four or five antennas. In both cases the transmitters send two independent data streams.

We underline since now that a total number of eight streams are not achievable in the four users network when the nodes are equipped with four antennas. As a matter of fact, analyzing the previous Figure 5.2(c) and Figure 5.2(d), it is clear that the percentage of interference in the desired signal subspace is not zero and according to the criterion previously introduced this interference alignment scheme is not feasible.

The reason that motivates us to take this scheme into account is to show how the infeasibility reflects in the bit error rates curves. Clearly, as this configuration is not achievable, we cannot use the `Min_WLI` algorithm since it would never converge. We also do not run `Min_WLI` in the second scenario of four nodes equipped with five antennas because the number of iterations needed to align the interference at each node and the convergence time of the algorithm are such as to make the utilization of this algorithm not feasible in practice. Additionally, in the light of the obtained results in the previously considered scenarios, we do not expect this algorithm to have such performances to justify its complexity.

For all of these reasons, for the four nodes interference channel we focus only on the performances of the `Max_SINR` algorithm. We give in Table 5.4

and Table 5.5 the values of the parameters of an interference channel with four nodes equipped with four or five antennas at each node, respectively. Figure 5.6 shows the performances of the **Max.SINR** algorithm in the two scenarios.

Number of nodes:	$K = 4$
Number of antennas per node:	$M = 4$
Degrees of freedom of the nodes:	$d_1 = 2 \quad d_2 = 2 \quad d_3 = 2 \quad d_4 = 2$
Achieved network multiplexing gain:	$r = 8$
Dimensionality of the matrices:	$\mathbf{H}_{ij} \quad \forall i, j \quad 4 \times 4$ $\mathbf{V}_1, \mathbf{U}_1 \quad 4 \times 2$ $\mathbf{V}_2, \mathbf{U}_2 \quad 4 \times 2$ $\mathbf{V}_3, \mathbf{U}_3 \quad 4 \times 2$ $\mathbf{V}_4, \mathbf{U}_4 \quad 4 \times 2$
No closed form solutions known of the beamforming matrices.	

Table 5.4: MIMO-IC: four nodes with four antennas sending two streams. System parameters.

Number of nodes:	$K = 4$
Number of antennas per node:	$M = 5$
Degrees of freedom of the nodes:	$d_1 = 2 \quad d_2 = 2 \quad d_3 = 2 \quad d_4 = 2$
Achieved network multiplexing gain:	$r = 8$
Dimensionality of the matrices:	$\mathbf{H}_{ij} \quad \forall i, j \quad 5 \times 5$ $\mathbf{V}_1, \mathbf{U}_1 \quad 5 \times 2$ $\mathbf{V}_2, \mathbf{U}_2 \quad 5 \times 2$ $\mathbf{V}_3, \mathbf{U}_3 \quad 5 \times 2$ $\mathbf{V}_4, \mathbf{U}_4 \quad 5 \times 2$
No closed form solutions known of the beamforming matrices.	

Table 5.5: MIMO-IC: four nodes with five antennas sending two streams. System parameters.

We first focus on the scenario with four antennas which we said to be infeasible. As the figure highlights, the infeasibility is shown by the fact that the bit error rate saturates slightly before the SNR assumes the value

of twenty dB. From this point onwards the bit error rate exhibits a constant trend, indicating that the limit of the system has been reached and a further increasing of the transmit does not enhance the performance.

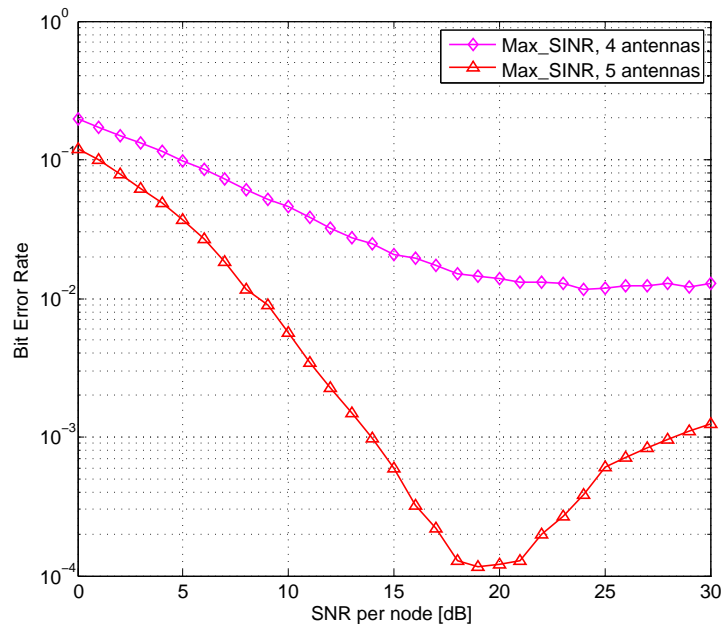

Figure 5.6: MIMO-IC: Max_SINR algorithm in a four nodes network.

When the nodes are equipped with five antennas and the transmitters send two independent streams to their desired receivers, the interference alignment is feasible (Figure 5.2(c) and Figure 5.2(d)). The bit error rate of the Max_SINR algorithm is substantially smaller than with only four antennas per node, confirming the feasibility of this configuration.

We note, however, a similar trend to the one noted in Figure 5.5. In this case as well there exist a value of SNR, roughly nineteen dB, after which, further increases in the transmit power generate only more interference to the other nodes causing a degradation of the performance.

5.3.5 MIMO-IC: Performances of the Max_SINR algorithm

We summarize in Figure 5.7 the performances, again in terms of bit error rate versus the SNR, of the distributed Max_SINR algorithm in all the scenario considered hitherto.

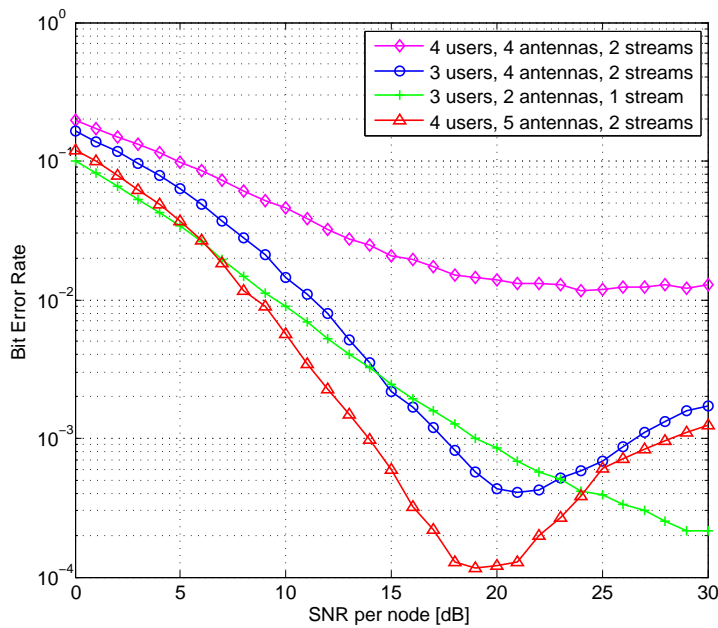

Figure 5.7: MIMO-IC: performances of the Max_SINR algorithm.

It is interesting to note that the values of SNR after which additional transmit power generates only interference are similar for the three users four antennas scenario and the four users five antennas case when the transmitter send two streams, and this value is around twenty dB. Furthermore for approximately the same value of SNR we also achieve the BER limit of the infeasible interference alignment scenario of four users equipped with four antennas sending two streams.

5.3.6 Performances of the closed form expressions of the beam-forming matrices for the SISO-IC and MIMO-IC

Finally, in Figure 5.8 we compare the performances of the interference alignment schemes for which there exist a closed form expression of the beam-forming matrices. Since the bit error rates are different for each user in a single antenna nodes interference channel, in this case we take the average of the values of the simulated BERs.

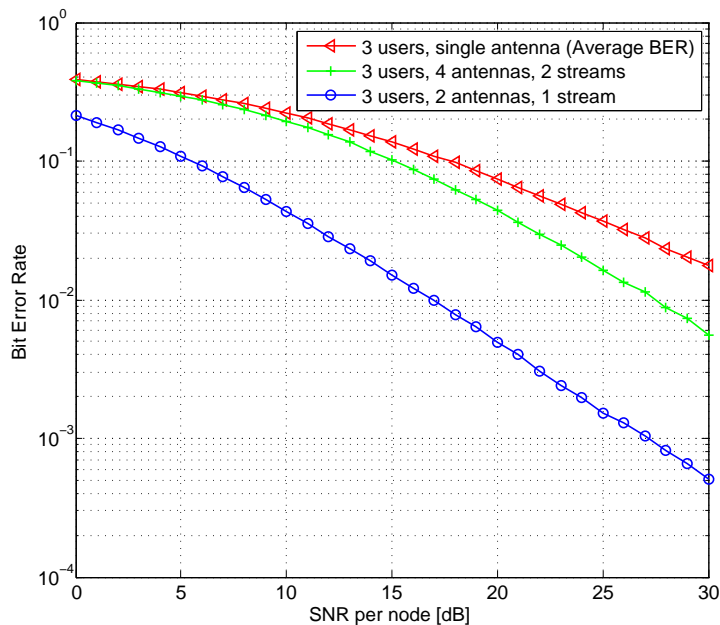

Figure 5.8: SISO-IC and MIMO-IC: three user closed form expressions.

We highlight that, for the system configuration that we are investigating, additional antennas used to send multiple streams can sometimes lead to a degradation of the performances, as it is the case of the three users interference network by doubling the number of antennas and the number of transmitted streams, from two to four and from one to two, respectively.

As stated before, in our opinion the higher bit error rate resulting in the three users four antennas case, is caused by the fact that we are using the additional antennas to increment the multiplexing gain of the network,

sending two streams instead of one, instead of providing additional diversity gain to enhance the reliability of the transmission.

5.4 Simulation results with noisy CSI

We investigate in this section the impact of noisy CSI on interference alignment systems. We will evidence the results only for the closed form solutions of the beamforming matrices. We remark that all the parameters of the system at both sides of the communication are calculated using the noisy versions $\tilde{\mathbf{H}}$ of the channel matrices.

The results are given as function of the ratio $\sigma_{\mathbf{H}}^2/\sigma_{\mathbf{E}}^2$, where \mathbf{H} indicates the original channel and \mathbf{E} the noise affecting the channel matrices. In all the following considered schemes simulations have shown that for values of $\sigma_{\mathbf{H}}^2/\sigma_{\mathbf{E}}^2$ approximately larger than twenty or thirty dB these schemes perform very close to the ideal condition of perfect CSI. We therefore give here the results only for noise variances below this value.

5.4.1 SISO-IC: three nodes single antenna with $n^* = 0$

All the three nodes in the network have shown to be affected by the noisy CSI in about the same manner so for the sake of clarity we plot in Figure 5.9 the average of the simulated BERs.

5.4.2 MIMO-IC: three nodes with two antennas sending one stream

We obtain the results depicted in Figure 5.10 for the MIMO-IC with three users equipped with two antennas. The use of two antennas instead of one at all the nodes make the system less sensitive to noisy channel state information. For values of SNR less than twenty dB and a noise variance such that $\sigma_{\mathbf{H}}^2/\sigma_{\mathbf{E}}^2 = 15$ dB the system still performs very close to the ideal case of perfect CSI.

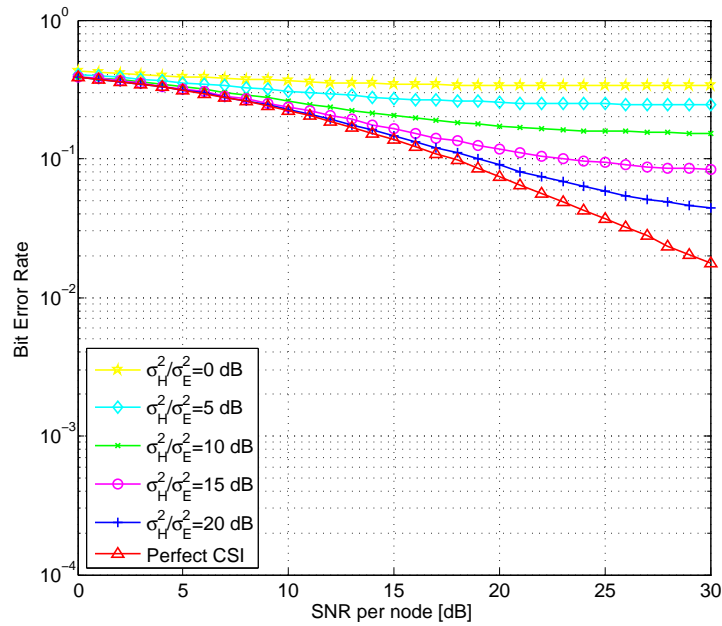

Figure 5.9: SISO-IC with Noisy CSI: three nodes single antenna with $n^* = 0$.

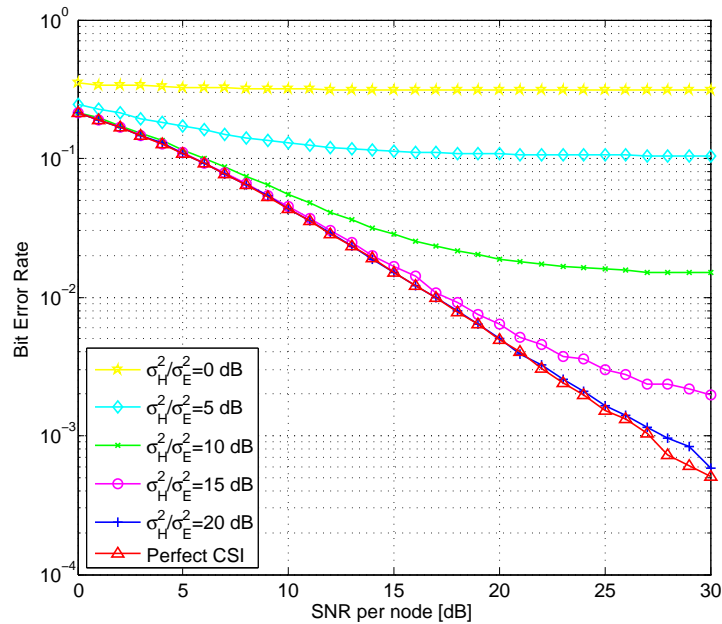

Figure 5.10: MIMO-IC with Noisy CSI: three nodes with two antennas sending one stream, closed form solutions of IA.

Conclusions and Future Work

In our work we have taken into account both closed form solutions of interference alignment, as well as distributed algorithms that permit to find the beamforming matrices iteratively. We have focused our attention on interference networks with three or four nodes equipped with single or multiple antennas.

The main contributions given by this work can be summarized as follows and for each point we briefly point out the further research directions that might arise from them.

1. We have extensively simulated the bit error rates of the implemented interference alignment schemes with three or four users at intermediate SNR values with perfect or noisy CSI (Chapter 5).
2. We have shown that in the three users SISO-IC the nodes experience different bit error rates and this difference cannot be simply attribute to different powers of transmit or receive filters. A more advanced analysis is needed, for instance by careful examining the relation between

the subspaces spanned by the transmitting and the receiving matrices (Section 5.3.1).

3. In the three users MIMO-IC with four antennas at each node we have exhibited that using additional antennas can cause more interference in the desired signal therefore deteriorating the bit error rates if techniques (e.g. a MMSE receiver) to exploit the additional diversity gain available are not used (Section 5.3.3).
4. We demonstrate the infeasibility of the MIMO-IC with four nodes equipped with four antennas sending two data streams by showing that, using the `Max_SINR` algorithm, the bit error rate saturates at moderate SNR values (Section 5.3.4), confirming the results on the numerical feasibility of interference alignment (Section 5.2).
5. Comparing the performance of the `Max_SINR` algorithm in the considered scenarios we infer that in some cases even if the interference alignment is feasible, the performances deteriorate when the SNR exceeds a threshold and further refinements (e.g. power control) to the original algorithm are needed (Section 5.3.5).
6. Based on simulations, we have estimated the sensitivity of certain interference alignment schemes to noisy CSI, showing that in three users interference networks the presence of two antennas instead on one make these schemes slightly more robust, however still a lot of research must be conducted in this direction in order to have interference alignment systems sufficiently robust to noisy CSI (Section 5.4).

Bibliography

- [1] A. B. Carleial, "Interference channels," in *IEEE Transactions of Information Theory*, vol. 24, no. 1, pp. 60-70, January 1978.
- [2] V. R. Cadambe and S. A. Jafar, "Interference alignment and the degrees of freedom for the K -user interference channel," in *IEEE Transactions of Information Theory*, vol. 54, no. 8, pp. 3425-3441, August 2008.
- [3] K. Gomadam, V. R. Cadambe and S. A. Jafar, "Approaching the capacity of wireless networks through distributed interference alignment," in *IEEE Global Telecommunications Conference 2008, GLOBECOM'08*, pp. 1-6, November 2008.
- [4] R. Tresh and M. Guillaud, "Cellular interference alignment with imperfect Channel Knowledge," in *IEEE International Conference on Communications 2009, ICC'09*, pp. 1-5, June 2009.
- [5] S. W. Choi, S. A. Jafar and S.-Y. Chung, "On the beamforming design for efficient interference alignment," in *IEEE Communications Letter*, vol. 13, no. 11, pp. 847-849, November 2009.
- [6] C. M. Yetis, S. A. Jafar and A. H. Kayran, "Feasibility conditions for interference alignment," in *IEEE Global Telecommunications Conference 2009, GLOBECOM'09*, pp. 1-6, November 2009.
- [7] V. R. Cadambe and S. A. Jafar, "Reflections of interference alignment and the degrees of freedom of the K user interference channel," in *IEEE Theory Society Newsletter*, vol. 59, no. 4, pp. 5-9, December 2009.

- [8] H. Sung, S.-H. Park K.-J. Lee and I. Lee, “Linear precoder designs for K-user interference channels,” in *IEEE Transactions of Wireless Communications*, vol. 9, no. 1, pp. 291-301, January 2010.
- [9] B. Li, Y. Luo and H. Shen, “A new precoding scheme using interference alignment on modulation signal for multi-user MIMO downlink,” in *IEEE International Conference on Wireless Communications and Signal Processing 2009, WCSP’09*, pp. 1-5, November 2009.
- [10] S. W. Peters and R. W. Heath Jr., “Interference alignment via alternating minimization,” in *IEEE International Conference on Acoustics, Speech and Signal Processing, ICASSP’09*, pp. 2445-2448, April 2009.
- [11] S. Gollakota, S. D. Perli and D. Katabi, “Interference alignment and cancellation,” in *ACM Special Interest Group on Data Communications Conference 2009, SIGCOMM’09*, August 2009.
- [12] M. Shen, A. Host-Madsen and J. Vidal, “An improved interference alignment scheme for frequency selective channels,” in *IEEE International Symposium on Information Theory 2008, ISIT’08*, pp. 559-563, July 2008.
- [13] H. Bolcskei and I. J. Thukral, “Interference alignment with limited feedback,” in *IEEE International Symposium on Information Theory 2009, ISIT’09*, pp. 1759-1763, July 2009.
- [14] K.-M. Zuleita Ho, M. Kaynia and D. Gesbert, “Distributed power control and beamforming on MIMO interference channels,” in *Proceedings of the European Wireless Conference 2010, EWC’10*, April 2010.
- [15] K.-M. Zuleita Ho and D. Gesbert, “Balancing egoism and altruism on the interference channel: The MIMO case,” in *Proceedings of the IEEE International Conference on Communications, ICC’10*, May 2010.
- [16] H. Shen, B. Li, M. Tao and Y. Luo, “The new interference alignment scheme for the MIMO interference channel,” in *Proceedings of the IEEE Wireless Communications and Networking Conference, WCNC’10*, April 2010.
- [17] D. Tse and P. Viswanath, *Fundamentals of Wireless Communication*, Cambridge University Press, Cambridge, UK, 2005.
- [18] N. Benvenuto and G. Cherubini, *Algorithms for Communications Systems and their Applications*, John Wiley & Sons, Chichester, UK, 2002.
- [19] G. Cariolaro, *La Teoria Unificata dei Segnali*, 2nd ed., UTET, Torino, Italy, 1996.

- [20] E. Biglieri, R. Calderbank, A. Constantinides, A. Goldsmith, A. Paulraj and H. V. Poor *MIMO Wireless Communications*, Cambridge University Press, Cambridge, UK, 2007.
- [21] O. E. Ayach, S. W. Peters and R. W. Heath Jr., “The feasibility of interference alignment of measured MIMO-OFDM channels,” submitted to the *IEEE Transactions on Vehicular Technology*, November 2009.
- [22] M. Joham, W. Utschick and J. A. Nossek, , “Linear transmit processing in MIMO communications systems,” in *IEEE Transactions of Signal Processing*, vol. 53, no. 8, pp. 2700-2712, August 2005.
- [23] M. Vu and A. Paulraj, “MIMO wireless linear precoding,” in *IEEE Signal Processing Magazine*, vol. 4, no. 5, pp. 86-105, September 2007.
- [24] J. G. Andrews, W. Choi, R. W. Heath Jr., “Overcoming interference in spatial multiplexing MIMO cellular networks,” in *IEEE Wireless Communications Magazine*, vol. 14, no. 6, pp. 95-104, December 2007.
- [25] D. Gesbert, M. Kountouris, R. W. Heath Jr., Chan-Byoung Chae and T. Sälzer, “Shifting the MIMO paradigm,” in *IEEE Signal Processing Magazine*, vol. 24, no. 5, pp. 36-46, September 2007.
- [26] E. G. Larsson, “MIMO detection methods: how they work,” in *IEEE Signal Processing Magazine*, vol. 26, no. 3, pp. 91-95, May 2009.
- [27] L. Zheng and D.N.C. Tse, “Diversity and multiplexing: a fundamental trade-off in multiple-antenna channels,” in *IEEE Transactions of Information Theory*, vol. 49, no. 5, pp. 1073-1096, May 2003.
- [28] Q. H. Spencer, C. B. Peel, A. L. Swindlehurst and M. Haardt, “An introduction to the multi-user MIMO downlink,” in *IEEE Communications Magazine*, vol. 42, no. 10, pp. 60-67, October 2004.
- [29] D. J. Love, R. W. Heath, Jr., W. Santipach and M. L. Honig, “What is the value of limited feedback for MIMO channels?,” in *IEEE Communications Magazine*, vol. 42, no. 10, pp. 54-59, October 2009.
- [30] M. Trivellato, S. Tomasin and N. Benvenuto, “Channel quantization and feedback optimization in multiuser MIMO-OFDM downlink systems,” in *IEEE Global Telecommunications Conference 2008, GLOBECOM'08*, pp. 1-5, November 2008.
- [31] G. Boudreau, J. Panicker, N. Guo, R. Chang, N. Wang and S. Vrzic, “Interference coordination and cancellation for 4G networks,” in *IEEE Communications Magazine*, vol. 47, no. 4, pp. 74-81, April 2009.

- [32] D. Astély, E. Dahlman, A. Furuskär, Y. Jading, M. Lindström and S. Parkvall, "LTE: The evolution of mobile broadband," in *IEEE Communications Magazine*, vol. 47, no. 4, pp. 44-51, April 2009.
- [33] S. Parkvall, E. Dahlman, A. Furuskär, Y. Jading, M. Olsson, S. Wänstedt, and K. Zangi, "LTE-Advanced - Evolving LTE towards IMT-Advanced," in *IEEE Vehicular Technology Conference 2008, VTC'08*, pp. 1-5, September 2008.
- [34] P. E. Mogensen, T. Koivisto, K. I. Pedersen, I. Z. Kovacs, B. Raaf, K. Pajukoski and M.J. Rinne, "LTE-Advanced: The path towards gigabit/s in wireless mobile communications," in *IEEE International Conference on Wireless Communication, Vehicular Technology, Information Theory and Aerospace and Electronic Systems Technology 2009, VITAE'09*, pp. 147-151, May 2009.
- [35] A. Hottinen, O. Tirkkonen and R. Wichman, *Multi-Antenna Transceiver Techniques for 3G and Beyond*, John Wiley & Sons, Chichester, UK, 2003.
- [36] H. Holma and A. Toskal, *WCDMA for UMTS: Radio Access for Third Generation Mobile Communications*, John Wiley & Sons, Chichester, UK, 2004.
- [37] E. Dahlman, S. Parkvall, J. Sköld and P. Beming, *3G Evolution: HSPA and LTE for Mobile Broadband*, 2nd ed., Academic Press, Oxford, UK, 2008.