

**Synthetic Receptors for the
Differentiation of Phosphorylated
Peptides
and
Synthesis and Use of Tetrahydrofuran
Amino Acids**

Dissertation

zur Erlangung des Doktorgrades der Naturwissenschaften

(Dr. rer. nat.)

an der Fakultät für Chemie und Pharmazie

der Universität Regensburg



vorgelegt von

Andreas Grauer

aus Neu-Ulm

2009

The experimental part of this work was carried out between October 2005 and December 2008 at the Institute for Organic Chemistry, University of Regensburg, Germany and the Shanghai Institute for Organic Chemistry, Shanghai, P. R. China under the supervision of Prof. Dr. B. König.

The PhD – thesis was submitted on:

25. February 2009

The colloquium took place on:

27. March 2009

Board of Examiners:

Prof. Dr. A. Göpferich

(Chairman)

Prof. Dr. B. König

(1st Referee)

Prof. Dr. O. Reiser

(2nd Referee)

Prof. Dr. A. Pfitzner

(Examiner)

*To Nicki
and my family*

Acknowledgements

I would like to express my sincere gratitude to Prof. Dr. B. König, for his continued guidance, advice and encouragement throughout this work.

For the chance to spend a two month internship at the Shanghai Institute of Organic Chemistry (SIOC) in China I would like to thank Prof. Dr. Dawei Ma. My special thanks go to all the Coworkers of the working group and to Dr. Sascha Breeger for their assistance, good collaboration and the friendly atmosphere.

Thanks are extended to the analytical departments of the University of Regensburg for the prompt and accurate measurement of my numerous, often difficult samples. Special thanks to Dr. T. Burgemeister and the rest of the NMR-department, Mr. J. Kiermaier and Mr. W. Söllner (MS), Mr. G. Wandinger and Mr. H. Schüller (elemental analysis) and Dr. R. Vasold (HPLC). I thank also the Prof. Dr. O. S. Wolfbeis and Dr. Axel Dürkop for the use of the CD spectrometer and the group of Prof. O. Reiser for the use of the IR spectrometer. Special thanks to Dr. M. Zabel and Ms. S. Stempfhuber from the X-ray crystallography for the measurement and interpretation of numerous crystals.

For the good collaboration within the scope of joint research projects I want to thank the groups of Dr. T. Berg (Max Planck Institut Martinsried), Dr. W. Diederich (Philipps-Universität Marburg) and in special Prof. Dr. C. Cabrele (Ruhr-Universität Bochum).

I would like to thank all my colleagues, past and present, for making the working environment positive, constructive as well as relaxed.

My special thanks go to:

Brian Moran, Allison Cheung and Claudia Stubinitzky for their efforts during their research periods in my laboratory.

My lab colleagues Dr. Stefan Ritter, Benjamin Gruber and Alexander Riechers for making sure that the days in the lab are lively and never boring or ordinary, for the discussions and great laughs.

Britta Badziura, Jens Geduhn and Carolin Fischer for their help with the "Practical Course Combinatorial Chemistry". Without you this course would have never worked so smoothly.

Dr. Giovanni Imperato for all the crazy stuff, lots of fun and the delicious Italian food.

Our great secretary Ms. L. Liebl for always keeping an eye on us and for her help with all the administrative hurdles.

My very special thanks go to:

Alexander Riechers for his cooperation leading to a great paper and for proofreading my papers and this work. Thanks also for lots of fun, countless discussions about chemistry and our projects but also about whisky and other non-chemical stuff. Thanks a lot, man!

Andreas Späth for an endless number of good discussion and in special for our great time in Shanghai and Münster.

Florian Schmidt for all the private discussions, the nice games of Worms and for all the fun we had.

Dr. Georg Dirscherl for all the discussions about sports and other things and for the fun time in and outside the lab.

Harald Schmaderer and Robert Lechner for always creating a good atmosphere in our group, for the nice trip to Italy and also for their constructive help in any situation.

My most and special thanks go to Nicole Schwarz for showing me that there is more in life than chemistry and working. Thanks for never letting me down, for your patience and your love.

My parents and my grand mother for their support and love.

*Basic research is what I'm doing
when I don't know what I'm doing.*

Wernher von Braun, 1912 - 1977

German rocket scientist

Content

A. Synthetic Receptors for the Differentiation of Phosphorylated Peptides	1
1. Introduction	1
1.1. Protein Phosphorylation	1
1.2. Analysis of Protein Phosphorylation	3
1.2.1. Chromatographic and Surface Device Techniques	3
1.2.1.1. Immobilized Metal-Ion Affinity Chromatography (IMAC)	3
1.2.1.2. Electrophoresis	4
1.2.1.3. Microarray Technology	6
1.2.2. GFP-FRET	7
1.2.3. Synthetic Metal Containing Receptors	8
2. Receptor Development	11
2.1. Potential Targets	12
2.1.1. The C-Terminal Domain of RNA Polymerase II	12
2.1.2. The Signal Transducers and Activators of Transcription	13
2.1.3. Target Peptide Sequences	15
2.2. Binding Sites	16
2.2.1. The Bis(Zn(II)-Cyclen) Triazine Complex 16	16
2.2.2. The Zn(II)-NTA Complex 17	19
2.2.3. The Guanidinium Moiety 20	20
2.3. Receptor Design	22
2.3.1. Receptors With Two Bis(Zn(II)-Cyclen) Triazine Complexes	23
2.3.2. Receptors With One Bis(Zn(II)-Cyclen) Triazine Complex and One Guanidine Moiety	24
3. Receptor Synthesis	26
3.1. Synthesis of the Tetra(Zn(II)-Cyclen) Receptors	26
3.2. Synthesis of the Fluorescent Tetra(Zn(II)-Cyclen) Receptors	33
3.3. Synthesis of the Bis(Zn(II)-Cyclen)-Guanidine-Receptors	41
4. Binding Studies	46
4.1. Binding Affinities Towards Different STAT Proteins	47
4.1.1. Binding Assay	47
4.1.2. Binding Results and Discussion	47

4.1.2.1. Inhibitory Effect Against the P1 -STAT1-Complex	48
4.1.2.2. Inhibitory Effect Against the P2 -STAT3-Complex	49
4.1.2.3. Inhibitory Effect Against the P3 -Gst-Lck-Complex	50
4.1.2.4. Summary	51
4.2. Binding Affinities Towards the Peptides P7 and P8	52
4.2.1. Binding Assay	52
4.2.2. Binding Results	53
4.2.3. Discussion of the Binding Results	58
5. Conclusion	61
6. Experimental Part	62
B. Synthesis and Use of Tetrahydrofuran Amino Acids	100
1. Introduction	100
1.1. Proteins	100
1.1.1. Protein-Protein Interactions	101
1.1.2. Protein Design	102
1.2. Peptidomimetics	105
1.2.1. Amino Acid Modifications	106
1.2.1.1. Side Chain Modification	106
1.2.1.2. Backbone Modification	109
1.2.2. Introduction of Global Restrictions	115
1.2.3. Synthetic Backbone Scaffolds	119
2. Synthesis of Novel C^α-tetrasubstituted α-Amino Acids	121
2.1. Introduction	121
2.2. Orthogonal Protecting Groups for the THF Amino Acid	124
2.3. Enantioselective Ring Formation	126
2.4. Aliphatic THF Amino Acids	128
2.5. Experimental Part	133
3. Stable Right- and Left-handed Peptide Helices	152
3.1. Introduction	152
3.2. Synthesis of the Peptides	153
3.2.1. Synthesis of Peptides Containing <i>S</i> -Valine	154
3.2.2. Synthesis of Peptides Containing <i>R</i> -Valine	156
3.3. Structure Analysis of the Synthesized Peptides	159
3.3.1. Solid State Structure Analysis	159
3.3.2. Solution Structure Analysis using NMR	163

3.3.3. Solution Structure Analysis using Circular Dichroism	169
3.4. Conclusion	173
3.5. Experimental Part	174
4. Derivatization of TAAs and the Synthesis of Cyclic Peptides	216
4.1. Introduction	216
4.2. Synthesis	218
4.2.1. Development of the CuI-Catalysis Reaction Conditions	218
4.2.2. Synthesis of Cyclic Tripeptide Mimics via C-N Arylation	223
4.2.3. Synthesis of Cyclic Tripeptide Mimics via C-O Arylation	226
4.3. Conclusion	229
4.4. Experimental Part	230
C. Abbreviations	273
D. References	277
E. Appendix	293

A. Synthetic Receptors for the Differentiation of Phosphorylated Peptides

1. Introduction

1.1. Protein Phosphorylation

Since the first isolation of phosphoserine (first described as serine phosphoric acid) in 1932 by *Levene* and *Lipmann*, protein phosphorylation has turned out to be one of the most biologically relevant and ubiquitous posttranslational modifications of proteins. Phosphorylation is a reversible modification affecting the folding and function of proteins, regulating nearly every basic cellular process, including metabolism, growth, division, differentiation, motility, organelle trafficking, membrane transport, muscle contraction, immunity, learning and memory.^{1,2} Protein kinases catalyze the transfer of the γ -phosphate from ATP to specific amino acids in proteins. In eukaryotes, these are usually the side chains of Ser, Thr and Tyr.

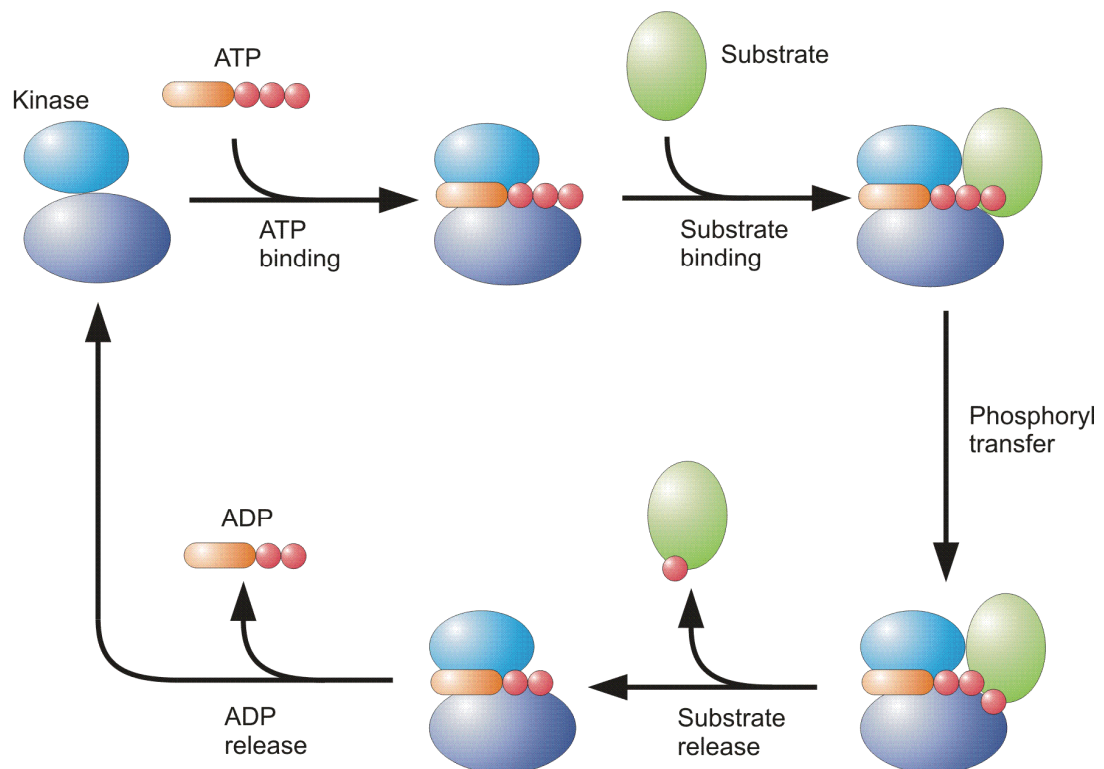

Figure 1: The basic catalytic cycle for substrate phosphorylation by a kinase (adapted from literature³).

According to comprehensive databases, the estimated number of phosphorylation sites in the mammalian proteome could be as high as 10^5 . 30-50 % of the entire proteome are estimated to be phosphorylated on at least one point.^{4, 5} If it is assumed that there are about 10,000 different proteins in a typical eukaryotic cell, with an average length of about 400 amino acids (of which 8.5 % are Ser, 5.7 % Thr and 3.0 % Tyr residues⁶), then there are approx. 700,000 potential phosphorylation sites for any given kinase. It is estimated that about 2 - 3 % of the eukaryotic genome is involved in phosphorylation processes, this fact additionally underlines the importance of protein phosphorylation.^{7, 8} For example, about 2 % of the human and also of the mouse genomes encode protein kinases with 518 and 540 distinct protein kinases found in human¹ and mouse,⁸ respectively. The analysis of the genome of *Saccharomyces cerevisiae* (baker's yeast) has revealed the presence of 123 protein kinases and 40 protein phosphatases, constituting approximately 2 % of the expressed yeast proteins.⁹ The interplay of kinases and phosphatases precisely regulates protein phosphorylation and dephosphorylation.

Among the amino acids which can be phosphorylated, serine, threonine and tyrosine are by far the most important. The occurrence of phosphorylation on Ser and Thr residues is more frequent than on Tyr residues, with the ratio pSer/pThr/pTyr in the order of 1800:200:1.¹⁰ The phosphoamidates of arginine, histidine and lysine also occur in nature, although they are less abundant.¹¹

1.2. Analysis of Protein Phosphorylation

Due to the biological importance, the analysis of protein phosphorylation is of paramount importance.¹² A variety of analytical tools are available for scientists to investigate, monitor or specifically inhibit the phosphorylation of proteins. These methods include radioisotope labeling, phosphoamino acid selective antibodies,¹³ chromatographic, staining or surface device techniques (see Chapter 1.2.1). Several biosensors for protein kinase activity based on GFP-FRET probes (see Chapter 1.2.2) or synthetic fluorescent probes¹⁴ which typically signal their own phosphorylation or dephosphorylation have also been reported. Recently, the group of *Hamachi et al.* reported a fluorescent dinuclear zinc complex for the detection of peptide phosphorylation and extended the concept to a hybrid receptor (see Chapter 1.2.3).¹⁵

In the following some of the above mentioned analytical methods will be discussed briefly.

1.2.1. Chromatographic and Surface Device Techniques

1.2.1.1. Immobilized Metal-Ion Affinity Chromatography (IMAC)

IMAC is the most frequently used technique for the separation and purification of phosphopeptides and phosphoproteins. It is based on interactions between metal ions immobilized on a solid support and biopolymers in solution. It was originally introduced for the purification of His-tagged proteins.¹⁶ Phosphorylated peptides or proteins are bound to an IMAC stationary phase by electrostatic interactions of the negatively charged phosphate group with positively charged metal cations bound to the resin beads via chelating groups like nitrilotriacetic acid (NTA), iminodiacetic acid (IDA) and tris(carboxymethyl)ethylenediamine (TED).¹⁷ Immobilized Fe(III), Ca(II) and Al(III) have been demonstrated to show high binding affinities towards phosphopeptides.¹⁸ Recently, immobilized Zr(IV) has been reported to bind phosphopeptides with high specificity.¹⁹ One of the major drawbacks of IMAC-based strategies is the nonspecific binding of peptides containing the acidic amino acids Glu and Asp, and the overly strong binding of multiply phosphorylated peptides. Nonspecific binding of acidic peptides can be reduced by esterification of carboxylic acids to methyl esters using HCl-saturated dried methanol, however this is obviously a denaturing step which is often undesired.²⁰

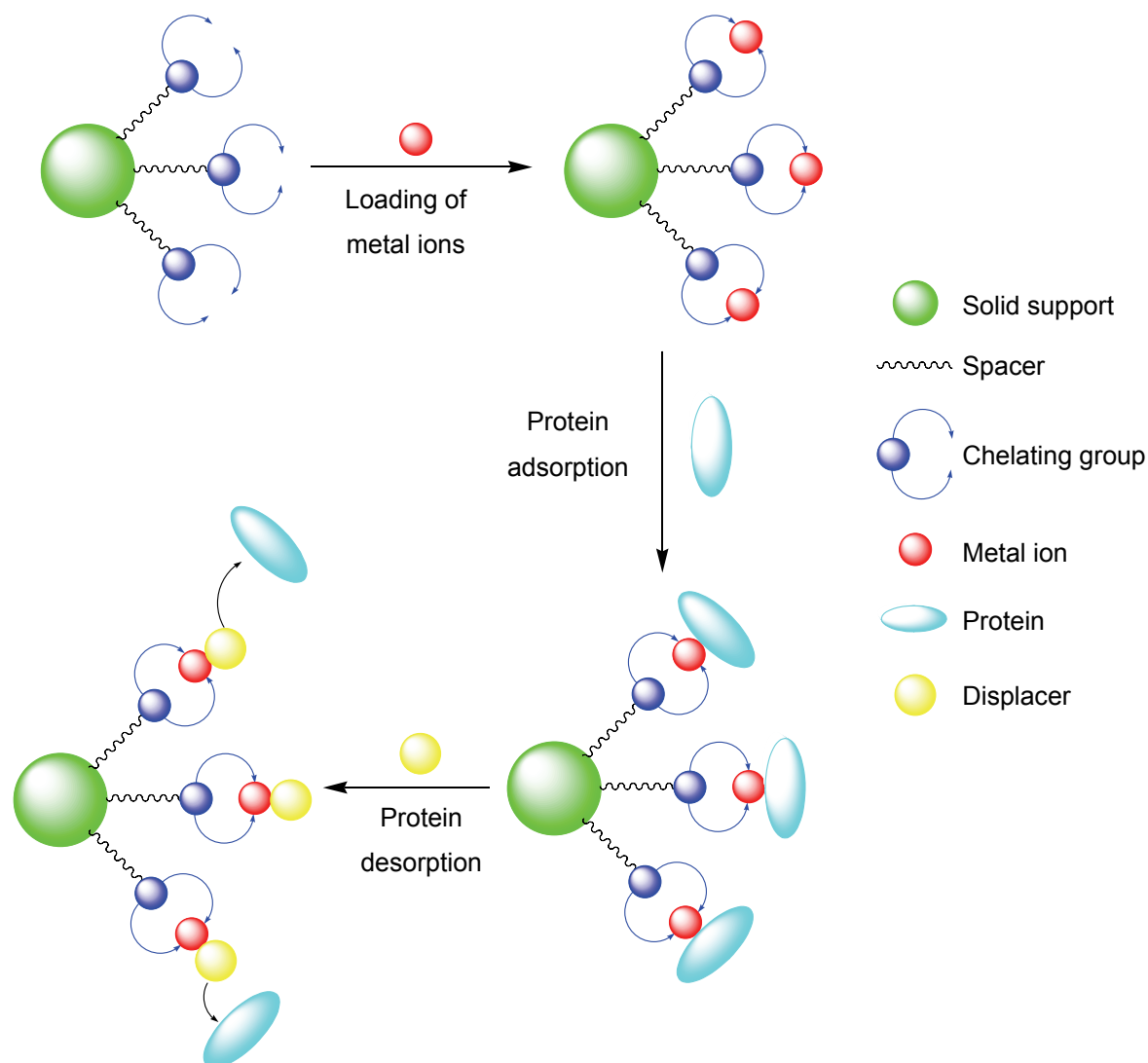

Figure 2: Schematic principle of the IMAC technique, adapted from literature.²¹

IMAC procedures have become very popular rapidly due to their good compatibility with other separation and detection techniques such as LC-ESI-MS/MS and MALDI-MS.²²

1.2.1.2. Electrophoresis

Kinoshita and coworkers developed a dinuclear metal complex (*i.e.* 1,3-bis[bis(pyridine-2-ylmethyl)amino]propan-2-olatodizinc(II) complex) which acts as a phosphate-binding tag (called Phos-tag) in an aqueous solution and is commercially available. The Phos-tag has vacancies on two metal ions that are suitable for binding of phosphatemonoester dianions as bridging ligands. Its high selectivity for phosphatemonoester dianions lead to the development of procedures for MALDI-TOF-MS,²³ IMAC²⁴ and surface plasmon resonance (SPR).²⁵

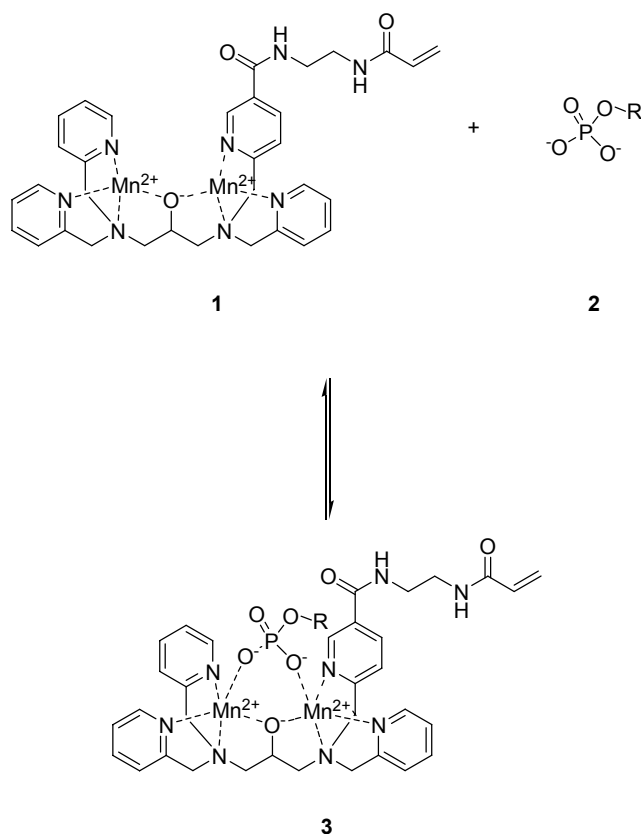

Figure 3: Structure of the Mn(II) Phos-tag complex **1** and scheme of the reversible capturing of a phosphatemonoester dianion **2**.

Recently, another application using complex **1** was reported by the same group. They were able to separate a phosphorylated protein from the corresponding nonphosphorylated one using a novel phosphate affinity sodium dodecyl sulfate-polyacrylamide gel electrophoresis (SDS-PAGE) technique. The dinuclear Mn(II) complex **1** was used as a gel additive to enhance the phosphate affinity of the SDS-PAGE. The principle of this method is as follows: phosphorylated proteins coordinate to the Mn(II)-Phos-tag ligand copolymerized into the gel and move therefore slower in the SDS-PAGE than the corresponding nonphosphorylated forms. This novel technique was successfully used to detect different proteins containing phosphorylated Ser, Thr and Tyr residues.²⁶ In addition, it was possible to perform an *in vitro* kinase activity profiling for the analysis of phosphoprotein isotypes derived from various kinases as well as an *in vivo* kinase activity profiling for the analysis of extracellular signal-dependent protein phosphorylation.²⁷

A similar metal complex based on a tyrosine was developed by König *et al.* The advantage of compound **4** is the in comparison to the previously synthesized Phos-tags more facile synthesis. They successfully used the Mn(II) complex as gel additive to separate phosphorylated proteins from unphosphorylated ones.²⁸

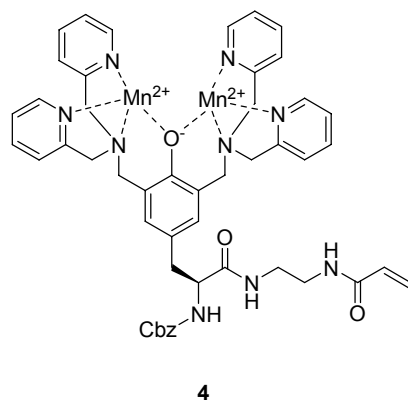

Figure 4: Structure of the acrylamide-pendant Mn(II) complex **4**.

In general, the Mn(II)-Phos-tag SDS-PAGE technique offers the significant advantages: (i) No radioactive or chemical labels are needed. (ii) The amino acid sequence plays no role for the phosphate binding specificity. (iii) A downstream procedure, such as Western blotting analysis, is possible. (iv) The procedure is almost identical to that of the general SDS-PAGE.²⁹

1.2.1.3. Microarray Technology

A method available for profiling the proteome without the use of separation techniques such as liquid chromatography, two-dimensional gel electrophoresis, or mass spectrometry is the use of microarray technology.³⁰ This new method offers the possibility to investigate the biochemical activities of proteins in a high-throughput and systematic manner.³¹ However, one limitation of antibody-based arrays is the difficulty to recognize isoforms of particular proteins that result from post-translational modifications, such as phosphorylation.³²

The feasibility of a microfluidic chip-based assay for measurements of cAMP-dependent protein kinase activity has been reported.³³ The lab-on-a-chip system is based on the phosphorylation of a fluorescein-labeled peptide. The additional negative charges from the phosphate group allow the separation of the phosphorylated from unphosphorylated peptides by capillary electrophoresis. The system could be used in the screening of protein kinase activators and inhibitors. Proof-of-concept studies for the detection of the phosphorylation of substrates by protein kinases on glass slides have been demonstrated using cAMP-dependent protein kinase, casein kinase II and p42 mitogen-activated protein (MAP) kinase.³⁴ Immobilized peptide chips for the quantitative analysis of protein kinase activity have recently been reported as well.³⁵ Additionally, the study demonstrated the feasibility of detecting protein kinase activity on these chips using an antibody raised

against phosphotyrosine in combination with surface plasmon resonance (SPR) or fluorescence microscopy.³⁶

1.2.2. GFP-FRET

Another technique to monitor protein phosphorylation in living cells is the use of fluorescent indicators. This method was developed to visualize second messengers such as Ca(II),³⁷ diacylglycerol,³⁸ cAMP³⁹ and cGDP.⁴⁰ The measurements based on these fluorescent indicators have been found to provide high spatial and temporal resolution sufficient for dissecting the single-cell events of the second messengers.⁴¹

In the last years, this method was also adopted for the study of kinase and phosphatase functions.

The principle of this method is shown schematically in Figure 5. A target substrate domain for a kinase of interest is connected with a phosphorylation recognition domain via a flexible linker sequence. The resulting substrate/linker/recognition unit is sandwiched between two differently-colored fluorescent proteins, cyan fluorescent protein (CFP) and yellow fluorescent protein (YFP). They are mutants of the green fluorescent protein (GFP) and serve as the donor and the acceptor fluorophores for fluorescence resonance energy transfer (FRET).⁴²

Phosphorylation of the substrate domain and subsequent binding of the phosphorylated substrate domain with the adjacent phosphorylation recognition domain induces FRET between the two fluorescent units and this in turn brings about the phosphorylation-dependent changes in fluorescence emission ratios of the donor and acceptor fluorophores. Upon activation of phosphatases, the phosphorylated substrate domain is dephosphorylated and the FRET signal is decreased.

This method has been used for the investigation of the phosphorylation kinetics in living cells by the use of a genetically encoded A-kinase activity reporter.⁴³ Another example is the use of the GFP-FRET technique for the *in vivo* analysis of CrkII phosphorylation by employing the property that CrkII changes its conformation upon intramolecular binding of the Src homology (SH) 2 domain to phosphorylated Tyr²²¹. Using this probe allowed the visualization of the rapid and transient phosphorylation of CrkII in living cells.⁴⁴

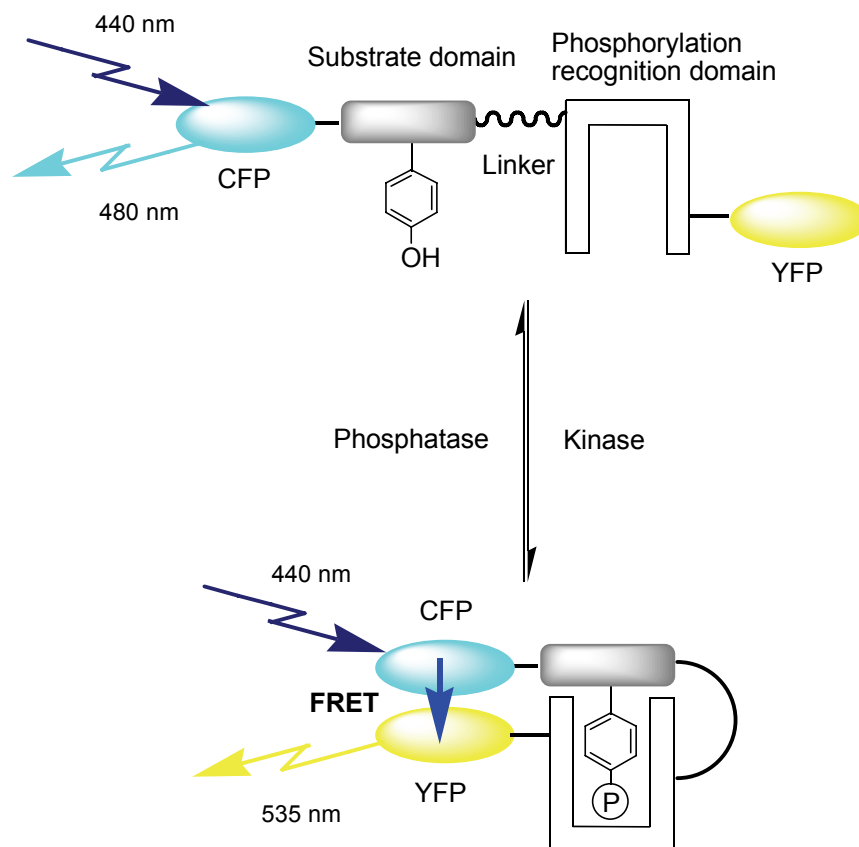

Figure 5: Fluorescent indicator for protein phosphorylation in living cells. Upon phosphorylation of the substrate domain by a kinase, the phosphorylation recognition domain binds to the phosphorylated substrate domain, which results in a change in the FRET intensity. (adapted from literature⁴⁵)

1.2.3. Synthetic Metal Containing Receptors

In 2002 *Hamachi et al.* introduced the Zn(II)-dipicolylamine (DPA) conjugated anthracene fluorophores **5** and **6** which can be applied to probing phosphorylated tyrosine and also phosphorylated peptides in aqueous media with association constants $\log K$ in the range of 4.1 - 7.3. The probes are based on suppression of the photoinduced electron transfer (PET) process. The fluorescence of **5** and **6** is increased four to five fold after recognition of a tyrosine-phosphorylated peptide having an overall negative charge. This, in turn, was not the case for the corresponding non-phosphorylated peptide.⁴⁶

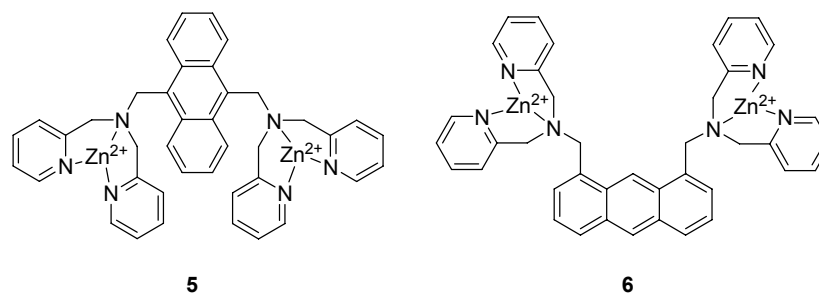

Figure 6: Fluorescent receptors **5** and **6** for the recognition of mono-phosphorylated peptides.

In an expansion of their previous work, *Hamachi et al.* developed the receptor **7** based on the Zn(II)-DPA recognition unit for the detection of a multiple-phosphorylated peptide in aqueous solution. In contrast to the above shown receptors **5** and **6**, the receptor **7** shows a decrease in fluorescence intensity after addition of the bis-phosphorylated target peptide. This is also the case when adding a mono-phosphorylated peptide but to a much lesser extent. An unphosphorylated peptide causes no change in fluorescence at all.⁴⁷

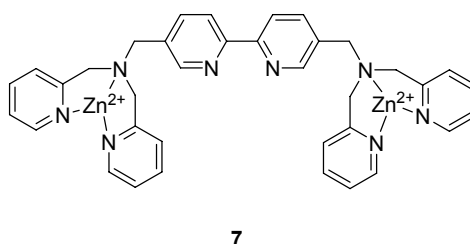

Figure 7: Fluorescent receptor **7** for the recognition of multiply-phosphorylated peptides.

Another probe, **8**, based on the Zn(II)-DPA motif was subsequently developed. It was employed to investigate the selectivity of the so-called Pin1 protein to the multiphosphorylated C-terminal domain (CTD) repeat sequence of RNA polymerase II via the phosphoprotein binding domain (WW domain). It was shown by X-ray crystallographic analysis that the Pin1 WW domain only interacts with one (pSer5) of two phosphate groups on a serine phosphorylated CTD peptide.

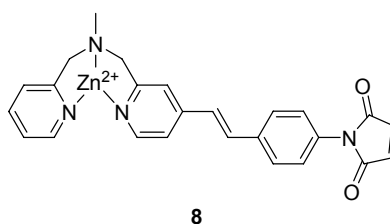

Figure 8: Artificial Zn(II)-DPA chemosensor.

It was intended to improve the binding affinity of the Pin1 WW domain for the CTD peptide by the introduction of the artificial probe **8**. The maleimide group of compound **8** was used to link it to a cystein residue which was introduced by mutation into the protein sequence of the WW domain. After addition of the bisphosphorylated CTD peptide the fluorescence intensity increased by about 60 %. The developed receptor was also used to establish real-time fluorescence monitoring of CDK9-catalyzed phosphorylation.^{15, 48}

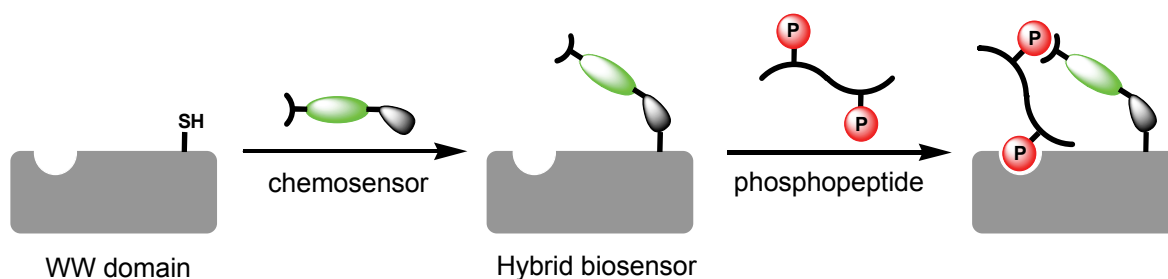

Figure 9: Construction of the hybrid biosensor with **8** and fluorescence sensing of a doubly phosphorylated peptide. (adapted from literature^{15a})

Another interesting approach towards the use of Zn(II) complexes for molecular recognition of phosphorylated compounds was presented by the groups of Kimura and König (see Chapter 2.2.1).

2. Receptor Development

The above shown examples are interesting and versatile, but the number of artificial systems for the specific recognition of phosphorylated peptides is still limited. Especially interesting is the work of *Hamachi et al.* with their ditopic receptor showing micromolar affinity and selectivity towards diphosphorylated peptides derived from sequences of the C-terminal domain of RNA polymerase II. This approach is appealing, but has the limitation of being only applicable for peptide sequences which show two phosphorylated amino acid side chains in close proximity to each other. We now seeked to expand this concept towards the synthesis of synthetic ditopic receptors which are able to bind phosphorylated peptide sequences, which in addition to the phosphate have a second amino acid residue present in the peptide that can also be bound by the ditopic receptor. Besides the phosphorylated amino acid, glutamic and aspartic acids as well as histidine were chosen as secondary recognition motif.

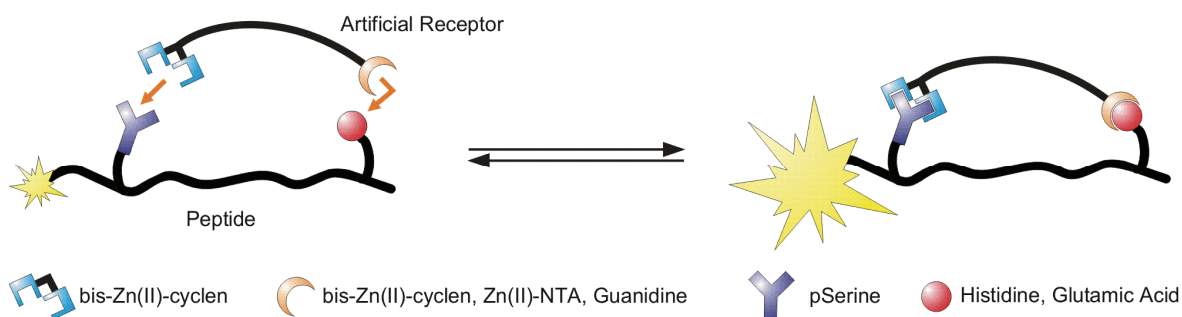

Figure 10: Exemplary binding event of the artificial ditopic receptors to their target peptides. The affinity can be determined for example by an enhanced fluorescence of the labeled peptide as shown in the cartoon. For further information about the selected binding sites of the receptors see Chapter 2.2.

2.1. Potential Targets

We chose peptide sequences resembling the C-terminal domain of RNA polymerase II and the signal transducers and activators of transcription for our ditopic receptors because of their great biological relevance.

2.1.1. The C-Terminal Domain of RNA Polymerase II

The synthesis of mRNA by the RNA polymerase II (Pol II) requires precise regulation of the different transcription steps as there are the initiation, elongation and termination processes. The transcription elongation process is affected in part by the binding of regulatory factors to the phosphorylated C-terminal domain (CTD) of the Pol II.⁴⁹ The binding of these factors depends on a specific CTD phosphorylation pattern, which changes during the transcription cycle, due to the action of CTD-modifying enzymes and coordinates events of nuclear mRNA biogenesis.⁵⁰

The CTD is linked to the Pol II via a flexible linker and forms an extension from the Pol II. Due to the high mobility of the linker and the CTD, they are not visible in the crystal structures of yeast Pol II.⁵¹ The CTD sequence consists of heptapeptide repeats of the sequence Tyr-Ser-Pro-Thr-Ser-Pro-Ser. The number of repeats depends on the species and is 26 in yeast and 52 in human. At least eight repeats are required for yeast viability.

52, 53

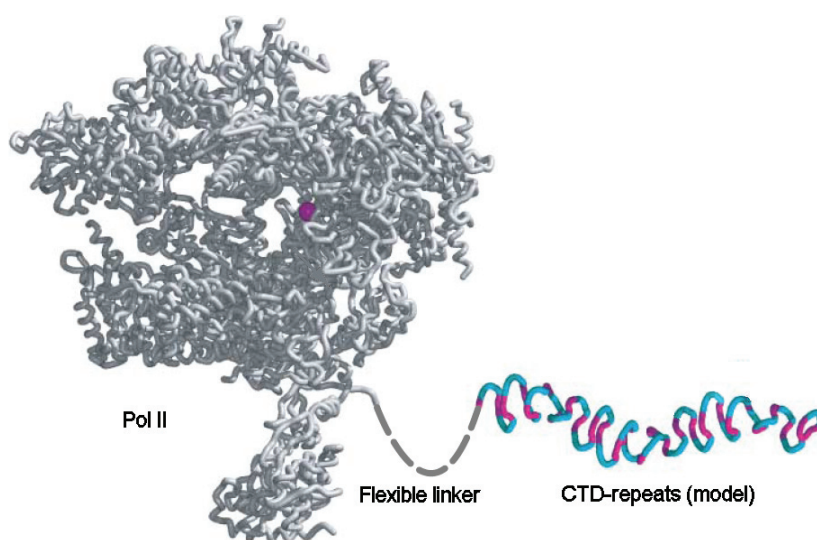

Figure 11: Pol II crystal structure and CTD β -spiral model. (adapted from literature⁵⁴)

The CTD can be modified at five of the seven side chains of one consensus repeat. However, CTD phosphorylation occurs mainly at Ser2 and Ser5 and these two phosphorylations are not equivalent in function.^{55, 56}

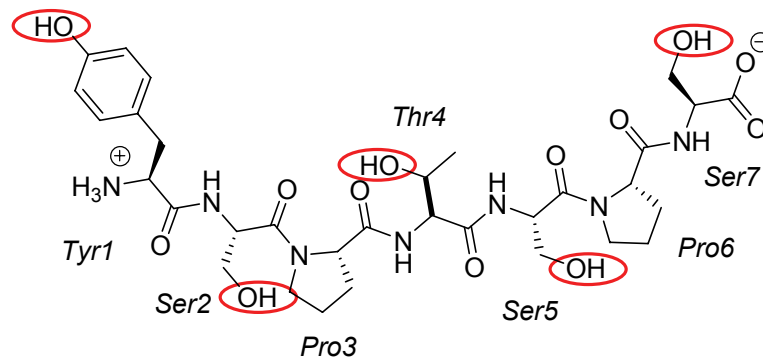

Figure 12: Structure of the diphosphorylated heptapeptide in complex.

Phosphorylation at Ser2 and Ser5 results in four different phosphorylation states of one CTD repeat. The phosphorylated form of Pol II carries, on average, one phosphate per repeat.⁵⁷ The exact phosphorylation state results from the balanced action of CTD kinases on the one side and phosphatases on the other side. During the transcription cycle the phosphorylation pattern changes, resulting in activation of specific RNA-processing factors. For example the CTD becomes phosphorylated at Ser5 during transcription initiation, while the adjacent transcription elongation is triggered by CTD phosphorylation at Ser2 residues.⁵⁸ Thus, it seems that the different CTD phosphorylation patterns connect distinct stages of the transcription cycle to the associated RNA-processing events.⁵⁹ During or after transcription termination, the CTD is dephosphorylated, resulting in Pol II recycling.

2.1.2. The Signal Transducers and Activators of Transcription

Other targets of interest were the signal transducers and activators of transcription (STATs). This family of transcription factors transduce signals from the surface of a cell to the nucleus.⁶⁰ Up to now, seven members of the STAT family were identified. STATs bind to activated cytokine receptors or to growth factor receptors via their Src homology 2 (SH2) domain. Upon ligand-induced receptor dimerisation, receptor-associated Janus kinases (JAKs) phosphorylate the cytokine receptors to create binding sites for the STATs. The STATs are phosphorylated after binding by JAKs or other cytoplasmic tyrosine kinases. This phosphorylation of STATs induces dimerisation by reciprocal phosphotyrosine-SH2 domain interactions. The so formed STAT dimers are then able to translocate to the nucleus, where they play an important role in the regulation of gene

expression.⁶¹ Due to the fact that the intracellular location of STATs depends on their activation state, they are often referred to as “latent cytoplasmic” transcription factors (see Figure 13).⁶²

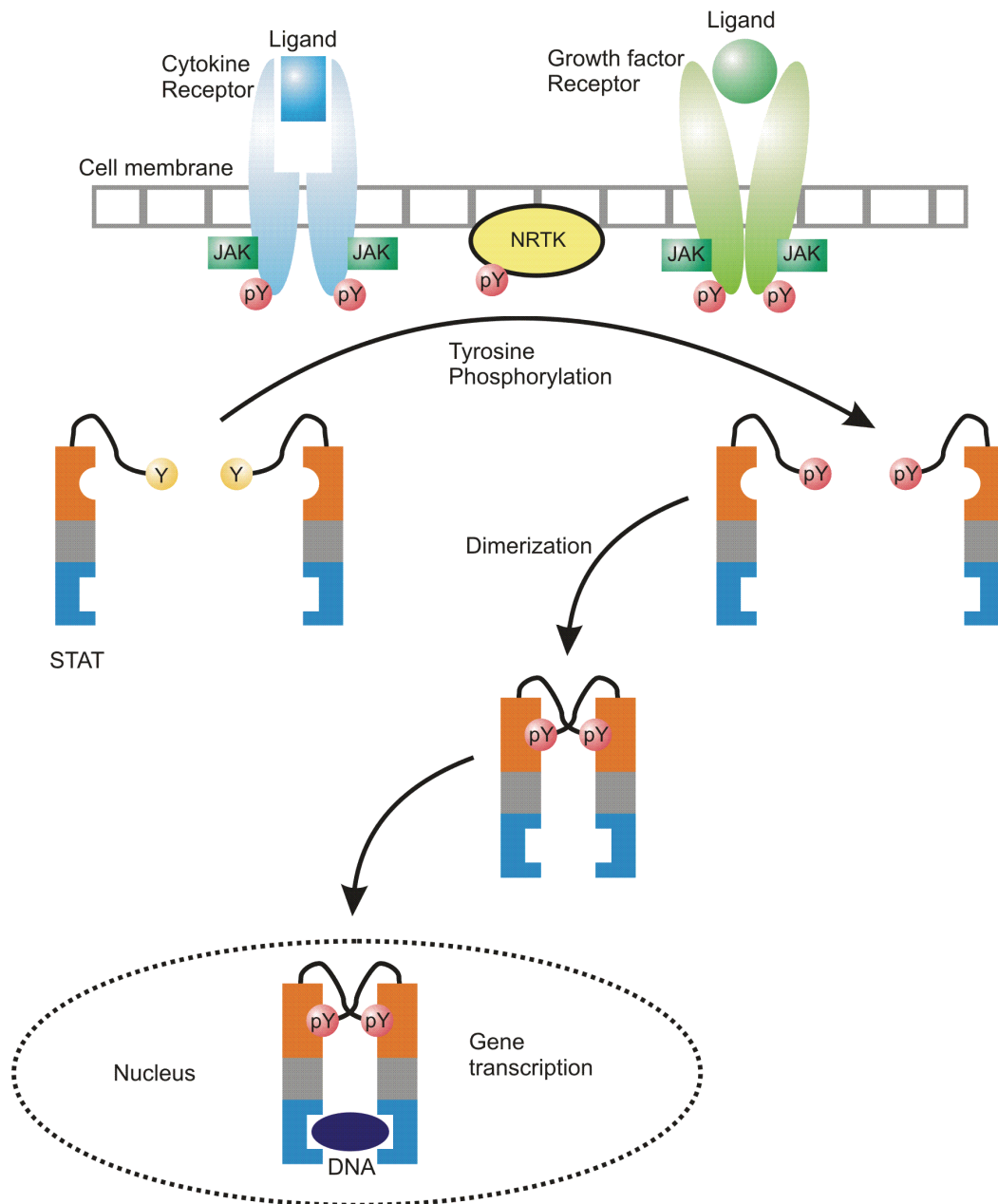

Figure 13: Simplified model of signal transduction via STATs. (adapted from literature⁶³)

One member of the STAT family, STAT3, has proven to be overactive in numerous of primary human tumors and also in tumor-derived cell lines.⁶⁴ Inhibition of constitutively active STAT3 results in growth inhibition and apoptosis of the tumor cell lines.⁶⁵ In common with other STAT proteins, also the STAT3 binds to phosphotyrosines at two stages in the activation of STAT3: firstly prior to the phosphorylation the binding of the activated kinase occurs and secondly the dimerisation of the phosphorylated STAT3

proteins takes place (see Figure 13). Therefore, small molecules like the complexes shown in this work could potentially be used as inhibitors for the STAT activation.

2.1.3. Target Peptide Sequences

After the STAT and the CTD proteins were chosen as the potential targets for the ditopic receptors, in the next step some target peptide sequences were chosen as starting point for the receptor development.

In the following some short peptide sequences derived from the CTD and STAT proteins are presented which were selected as potential targets for the receptors. All of the peptides have at least two amino acids with functional groups which could serve as binding partners for the different receptor moieties presented in the following Chapter 2.2. All peptides have a phosphorylated tyrosine, threonine or serine and in addition a second function like a glutamic acid, aspartic acid, histidine or a second phosphorylated amino acid. They were derived either from the active centers of kinases known to be involved in the STAT phosphorylation process (**P1** – **P5**) or from the CTD sequence (**P6**).

- | | | |
|----|---|------|
| a) | Carboxyfluorescein–Gly-pTyr-Asp-Lys-Pro-His-Val-Leu-OH | (P1) |
| b) | 5-Carboxyfluorescein–Gly-Phe-Asp-pThr-Tyr-Leu-Ile-Arg-Arg-OH 5- | (P2) |
| c) | 5-Carboxyfluorescein–Gly-pTyr-Glu-Glu-Ile-Pro-OH | (P3) |
| d) | 5-Carboxyfluorescein–Gly-pTyr-Leu-Val-Leu-Asp-Lys-Trp-OH | (P4) |
| e) | 5-Carboxyfluorescein–Gly-pTyr-Leu-Pro-Gln-Thr-Val-NH ₂ | (P5) |
| f) | H-Tyr-pSer-Pro-Thr-pSer-Pro-Ser-OH | (P6) |

The red marked phosphorylated tyrosine, threonine or serine residues can be bound by the bis(Zn(II)-cyclen) complex. As a secondary binding site, histidine (marked in green) in the sequence of **P1** could be coordinated by the bis(Zn(II)-cyclen) complex or the blue marked glutamic or aspartic acids (sequences **P1** - **P5** which might be bound by a guanidinium moiety or a Zn(II)-NTA complex are possible targets.

In addition, peptides **P1** - **P5** are labeled with the fluorescent dye 5-carboxyfluorescein, thus making it possible to use fluorescence intensity or fluorescence polarization spectroscopy as method for the determination of the binding affinities.

2.2. Binding Sites

After the target peptides were selected and with that also the side chains which could be bound by our ditopic receptors (pSer, pTyr, pThr, His, Asp and Glu), the receptor binding sites for those amino acids were chosen.

The bis(Zn(II)-cyclen) triazine complex **16** was selected as the binding site for the phospho amino acids and the histidine side chain. The Zn(II)-NTA complex **17** and a guanidinium moiety **20** were chosen to bind the side chains of the glutamic and aspartic acids.

2.2.1. The Bis(Zn(II)-Cyclen) Triazine Complex **16**

1,4,7,10-Tetraaza-cyclododecane (also [12]aneN₄ or cyclen) is able to incorporate a metal ion into its center. The metal cation is bound by the free electron pairs of the four ring nitrogen atoms. Such complexes are known of a variety of metals like Zn(II), Ni(II), Cu(II), Cd(II), Co(III) but also Rh(III) and Ru(II).⁶⁶ Of special interest is here Zn(II) because complexes of this ion with cyclen have proven their ability to bind phosphate monoesters in several tests. Ni(II), Cu(II) and Cd(II) in the contrary show no affinity towards phosphate monoesters.^{66, 67}

It was also already shown that phosphate esters can coordinate up to three Zn(II) cyclen complexes at the same time.⁶⁸ This offers the possibility to create a receptor by linking two or even three cyclen complexes with each other. Such a molecule should have an increased selectivity and also a higher binding constant. *Kimura et al.* were able to show that the affinity constant of a Zn(II)-cyclen complex containing receptor towards 4-nitrophenyl phosphate (NPP²⁻) and also phenyl phosphate (PP²⁻) increases by incorporating more complexes into the receptor.⁶⁹

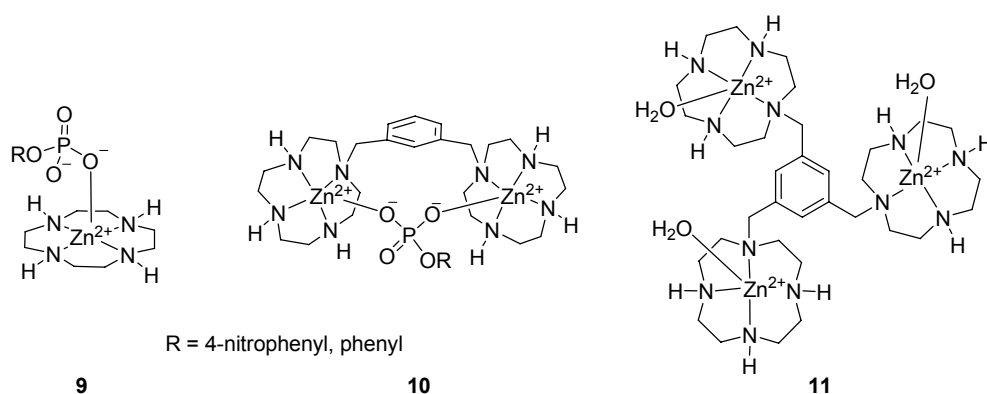

Figure 14: Mono-, bi- and tridentate complexes of Zn(II)-cyclen used by *Kimura et al.* Counter ions were omitted for clarity.

The affinity constants ($\log K$) for the Zn(II)-cyclen **9** towards NPP^{2-} and PP^{2-} are 3.1 for the former and 3.5 for the latter. Those determined for the bis-Zn(II)-cyclen **10** are 4.0 and 4.6, respectively. For the tris-Zn(II)-cyclen **11** the binding constants are even higher with 5.8 for the coordination of NPP^{2-} and 6.6 for the binding to PP^{2-} .⁷⁰

In addition to the affinity of bis-Zn(II)-cyclen complexes towards phosphate-monoesters, these complexes also have proven to be able to bind nitrogen containing compounds like barbital,⁷¹ thymidine 3'-monophosphate⁷² and imidazole.^{73, 74}

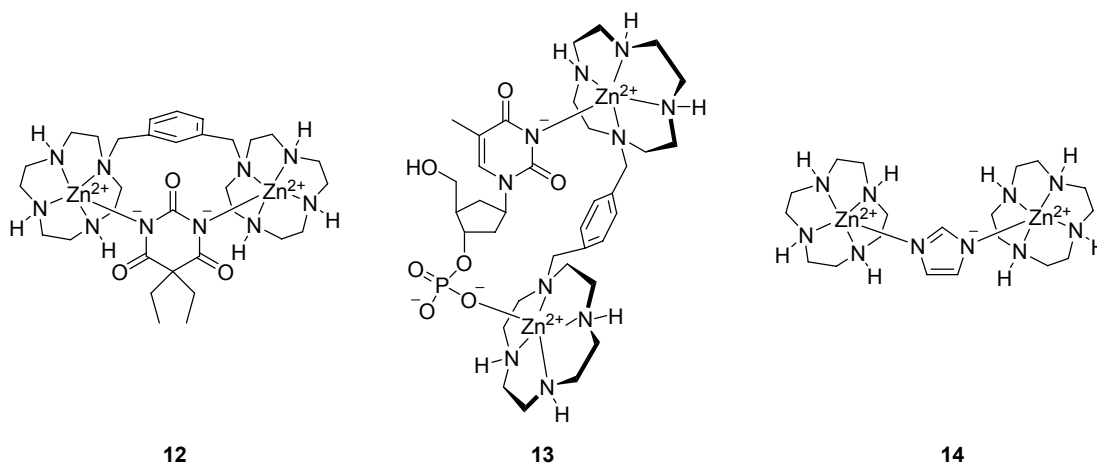

Figure 15: Binding of barbital and thymidine 3'-monophosphate to bis(Zn(II)-cyclen) (left and center); drawing of a complex of two Zn(II)-cyclens coordinated to one imidazole (right). Counter ions were omitted for clarity.

The binding constants of the bis(Zn(II)-cyclen) complex **10** towards their targets are in a range of $\log K = 5.5 - 6.4$ as determined by potentiometric titrations which is nearly two orders of magnitude higher than the affinity of the mono(Zn(II)-cyclen) **9**.⁷⁵

As binding moiety, we selected the bis-cyclen compound **15** developed by our group¹⁰⁵ because it is rigid and the triazine has an additional site available for further functionalization.

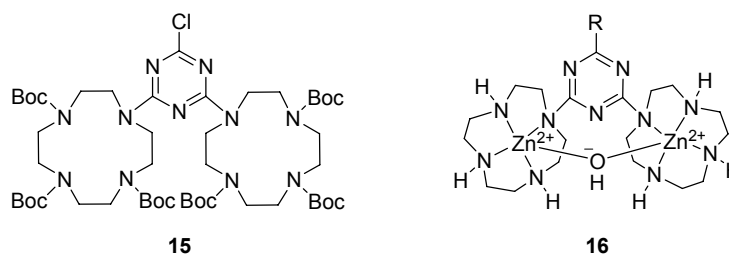

Figure 16: Protected ligand **15** developed by our group (left) and the resulting bis(Zn(II)-cyclen) triazine complex **16** (right) after deprotection and complexation of two Zn(II) ions. Counter ions were omitted for clarity.

The bis(Zn(II)-complex) **16** was previously used in a rational approach to control molecular recognition of phosphate, nucleobases, and nucleotides on 2-D templates presenting amphiphilic bis(Zn(II)-cyclen) assembled at the air/water and water/solid interfaces. In these systems, the metal-complexes act as highly specific divalent hosts for phosphate and imide groups.⁷⁶

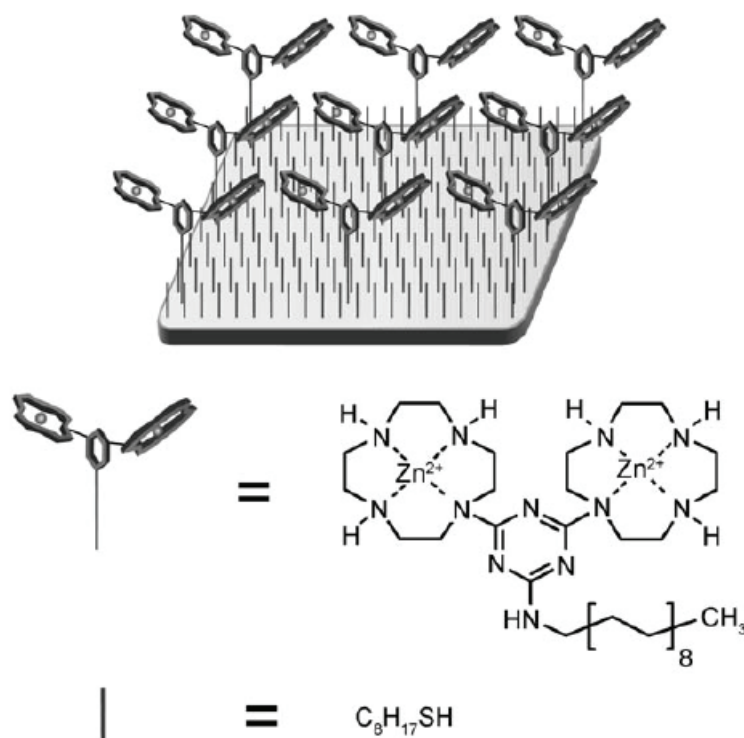

Figure 17: Schematically drawn structure of a SAM-supported monolayer of bis(Zn(II)-cyclen) on a gold-coated surface.⁷⁶

The amphiphilic bis(Zn(II)-cyclen) derivatives are ordered into a planar matrix through Langmuir-Blodgett (LB) transfer of bis(Zn(II)-cyclen) monolayers from an aqueous subphase onto a gold-coated surface covered with a loosely packed self-assembled monolayer (SAM) of octanethiol (see Figure 17). This combination of SAM and LB techniques preserves the uniform order of the precursor monolayer and gives a stable, interdigitated bilayer with macrocyclic fragments exposed to the solution. The bis(Zn(II)-cyclen) immobilized in such a film is capable of binding nucleotide constituents modeled with uracil and an inorganic phosphate dianion while no binding to adenine or monoanionic phosphates was observed.⁷⁷

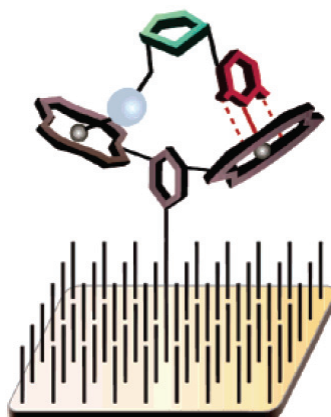

Figure 18: Schematic illustration of the divalent binding mode for 5'-UMP attached to the SAM/bis(Zn(II)-cyclen) surface.⁷⁷

2.2.2. The Zn(II)-NTA Complex 17

Nitrilotriacetic acid (NTA) has been widely used as a chelate for more than 60 metal ions.⁷⁸ Most common are NTA complexes of Al(III),⁷⁹ Cu(II),⁸⁰ Ni(II),⁸¹ Zn(II),⁸² Cr(II and III)⁸³ and Fe (II and III).⁸⁴

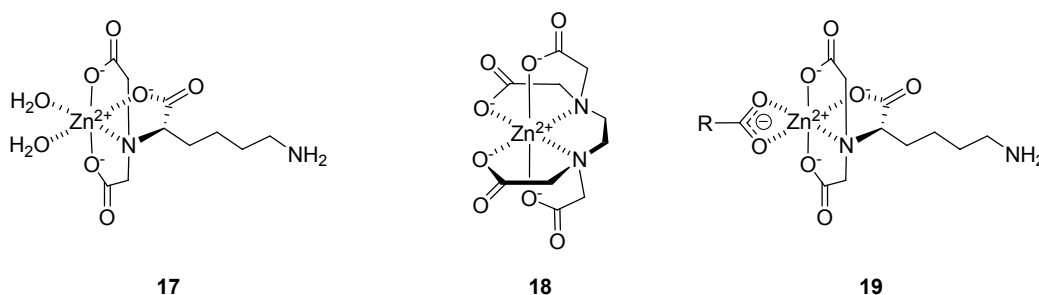

Figure 19: Zn(II) complex **17** of the lysine NTA derivative used in this work with the two free valences (left), Zn(II)-EDTA complex **18** (center) and the expected Zn(II)-NTA complex **19** coordinated to a carboxylate (right).

As metal ion, Zn(II) was chosen because unlike Cu(II)- and Ni(II)-NTA complexes which bind imidazole and are widely used for the purification of His-tagged proteins by immobilized metal affinity chromatography (IMAC),^{85, 86} the binding affinity of Zn(II)-NTA complexes for imidazole is significantly reduced.⁸⁷ However, the NTA ligand also represents a truncated EDTA motif which itself is known to bind Zn(II) with an affinity of $\log K = 16.5$.⁸⁸ Accordingly, it can be expected that a carboxylate can coordinate to the two unoccupied coordination sites in the Zn(II)-NTA complex intramolecularly, thus completing

a mimic of an EDTA coordination sphere.⁸⁹ Intermolecularly, this interaction has already been described.⁹⁰

As shown in Figure 19, the NTA ligand forms an octahedral complex with the Zn(II) as central ion, in which the nitrilotriacetic acid's three carboxylic acid groups and the tertiary amine form a tetradentate chelation around the metal cation. This leads to the formation of three five-membered rings.⁹¹ The two free valences which are left after the coordination of the NTA to the metal ion are occupied in the free complex by non-chelating oxygen atoms from other $[\text{Zn}(\text{NTA})]^-$ ions and can be used for the binding to the carboxylic side chain of amino acids like glutamic or aspartic acid.⁹²

2.2.3. The Guanidinium Moiety **20**

The guanidinium moiety is a common motif in biology and is widely used as mediator of specific non-covalent binding⁹³ of different enzyme substrates (e.g. like lactate by the enzyme lactate dehydrogenase) or the base pairing in nucleic acids (guanine is an acylated guanidine).

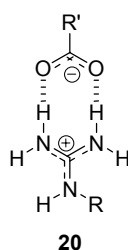

Figure 20: Diagram of a protonated planar guanidinium group, showing 2 hydrogen bonds to a carboxylic acid.

Based on its important role in nature, the guanidinium group has attracted much attention especially from the supramolecular community.⁹⁴ However, most investigations were limited to organic solvents of low polarity, due to the fact that the ion pairs between guanidinium cations and oxoanions are normally stable only in this kind of media. In aqueous solutions, the competing solvation of both donor and acceptor sites significantly reduces the ion pair stability.⁹⁵ Of course, this is no problem for nature because of the rather hydrophobic interior of proteins where such ion pairing normally occurs.⁹⁶ However, for synthetic receptors the weak binding of ion pairs in polar solvents represents a severe limitation. This is especially the case for any application of such supramolecular systems. Nevertheless, in the recent years different guanidinium based compounds were synthesized which show high affinities to oxoanions even in water.^{97, 98}

One example of oxoanion binding guanidinium cations and additional binding sites in water is shown in Figure 21. *Schmuck et al.* used a focused combinatorial library to find a hit for their target tetrapeptide, Ac-Val-Val-Ile-Ala-OH **22**.⁹⁹ This short peptide represents the C-terminal sequence of the amyloid- β -peptide ($A\beta$) which is responsible for the formation of protein plaques within the brain of patients suffering from Alzheimer's disease.¹⁰⁰ An artificial receptor such as **21** could be useful to derive more information about the molecular basis of the self-aggregation of the amyloid-peptide.¹⁰¹ To identify which amino acid side chain in the receptor is most important, a library of 512 different but structurally related receptors **21** was synthesized and screened.^{102, 103} The binding affinity of the best hits from the screening was afterwards determined in buffered water. The data showed that exceptionally strong binding occurred with association constants of up to 10^4 M^{-1} for the best receptors.^{99a}

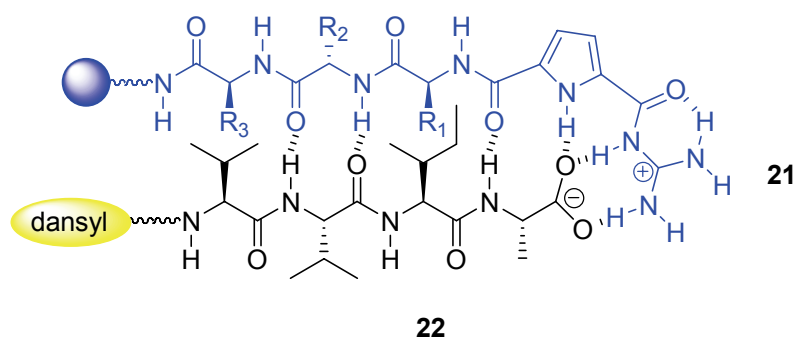

Figure 21: A tripeptide based library of cationic guanidinocarbonyl pyrrole receptors **21** (blue) designed for the binding of Dansyl-Val-Val-Ile-Ala-OH **22**, a tetrapeptide model representing the C-terminus of $A\beta$ (black).

2.3. Receptor Design

As previously shown, three different types of receptor moieties, the bis(Zn(II)-cyclen) triazine complex **16**, the Zn(II)-NTA complex **17** and the guanidinium moiety **20** have been combined in different ways to form ditopic receptors with an increased affinity and selectivity in comparison to the single receptors. As all potential target peptides possess a phosphorylated amino acid either a tyrosine, a serine or a threonine, every receptor has as one recognition functionality a bis(Zn(II)-cyclen) triazine complex **16**. As additional binding unit, a second bis(Zn(II)-cyclen) triazine complex **16**, a Zn(II)-NTA complex **17** or a guanidinium moiety **20** were chosen. This led to three groups of receptors which were expected to be able to selectively recognize different patterns in phosphorylated peptide sequences.

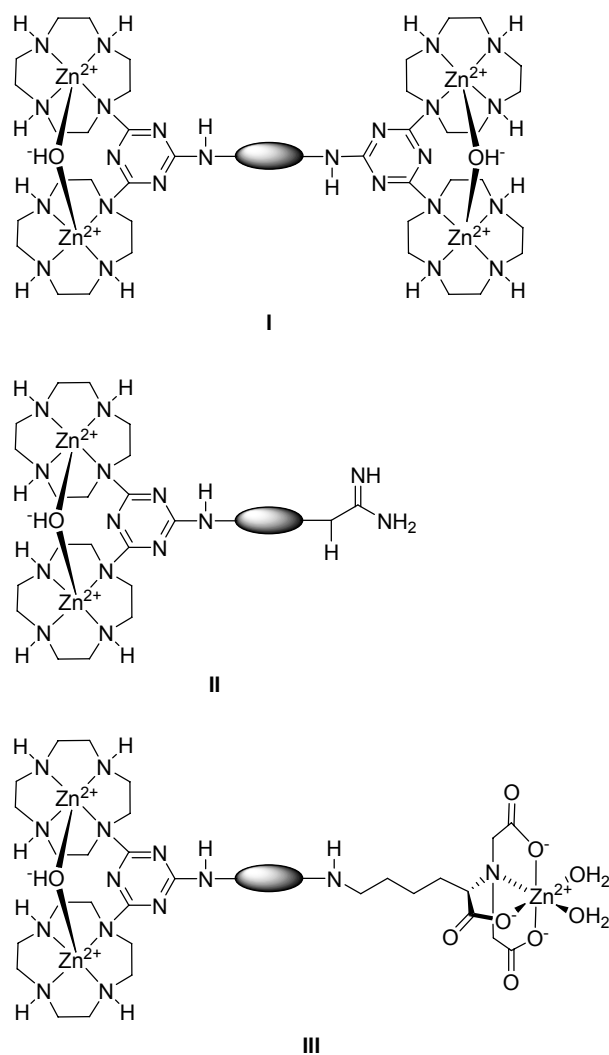

Figure 22: The three different groups of receptors, all of which contain a bis(Zn(II)-cyclen) triazine complex **16** and as second binding site a second bis(Zn(II)-cyclen) triazine complex **16**, a Zn(II)-NTA complex **17** or a guanidinium moiety **20**.

The receptor group **I** was expected to selectively bind to peptides containing either two phosphorylated amino acids in the side chain or a combination of one phosphate mono ester and an imidazole group. The second group **II** in which a guanidine is incorporated instead of the second bis(Zn(II)-cyclen) triazine complex **16** should have a high affinity to peptides containing one phosphorylated amino acid and in addition a glutamic or aspartic acid as binding partner for the guanidinium group **20**. The third and last group **III** where a bis(Zn(II)-cyclen) triazine complex **16** and a Zn(II)-NTA **17** complex form the receptor should bind to phosphorylated peptides containing a glutamic or aspartic acid as a second group. The synthesis of this last group will not be presented here as these compounds were already prepared in the scope of my diploma thesis.¹⁰⁴

2.3.1. Receptors With Two Bis(Zn(II)-Cyclen) Triazine Complexes

For the receptor group **I** a spacer molecule containing two amine functionalities which would offer the possibility to introduce both protected bis-cyclen triazines **15** in one step was synthesized. A variety of spacers with different lengths and functionalities, for example fluorescent groups is possible.

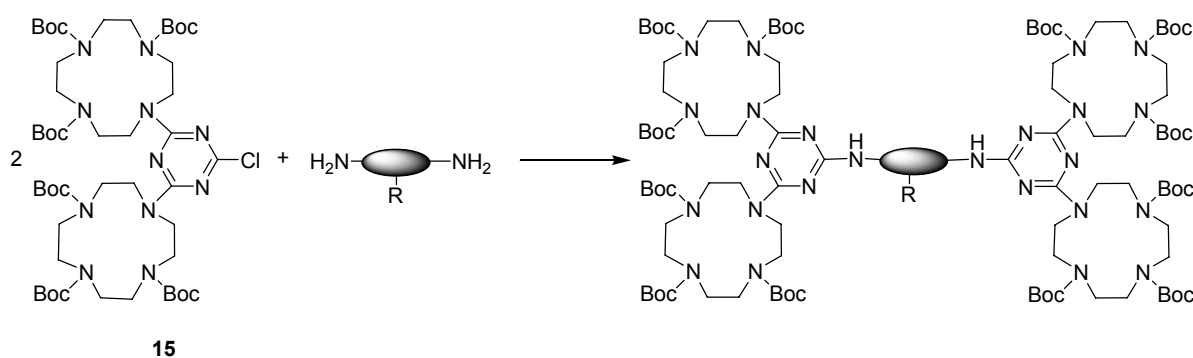

Figure 23: Synthesis of group **I** receptors.

As spacers between the two binding sites several diamines were chosen. The shortest spacer was the commercially available butane-1,4-diamine **23**. For the longer linkers **24** and **25** ethylenediamine in combination with glycine or glycyglycine were used. Due to the amide bonds introduced into the chain these spacers are more rigid than the alkyl diamines of the same length. Additionally this modular synthesis of the linkers offered the possibility to introduce other amino acids instead of the glycine. One example is the diamine **26**. Here glycine was replaced by a lysine which makes it possible to add a further functionality to the receptor. The introduction of a fluorescent group like the dansyl unit would allow the use of fluorescence spectroscopy for the determination of the binding abilities of the several receptors.

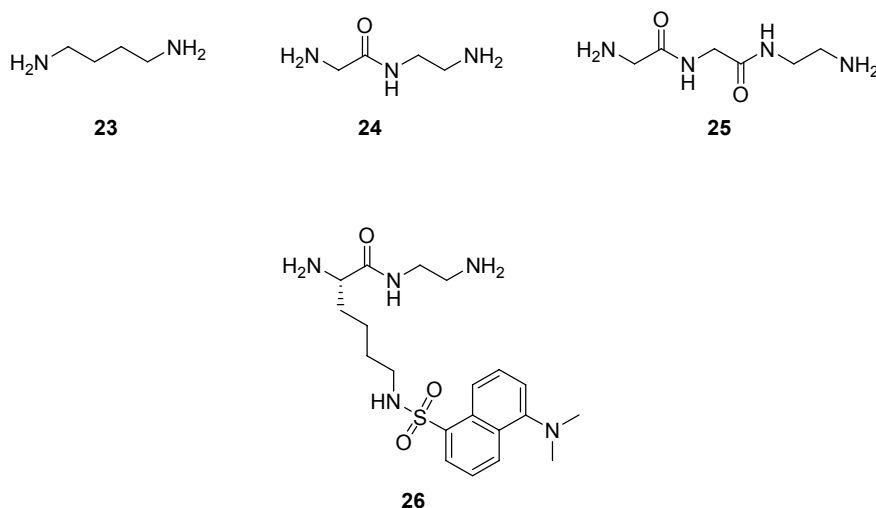

Figure 24: Spacer molecules.

In addition to above shown flexible linkers also two spacer molecules were chosen which are very rigid, resulting in receptors with defined distance of the two recognition moieties. These spacers are fluorescent due to their large conjugated ring system, offering the possibility to study also peptide sequences like **P6** which are not labeled with a dye. Two fluorescent aromatic dianhydrides, the naphthalene-1,4,5,8-tetracarboxylic dianhydride **27** and the perylene-3,4,9,10-tetracarboxylic dianhydride **28** were chosen. With these dianhydrides the synthesis had to be changed as the two spacer molecules do not bear any amine functions necessary for the substitution reaction shown in Figure 23. Therefore it was decided to functionalize the protected bis-cyclen triazine **15** with ethylene diamine before using it in the reaction with the dianhydrides **27** and **28**.

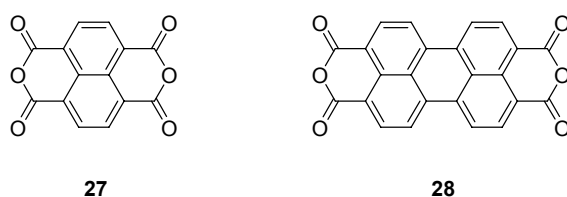

Figure 25: Rigid, fluorescent spacer molecules.

2.3.2. Receptors With One Bis(Zn(II)-Cyclen) Triazine Complex and One Guanidine Moiety

For the receptors containing a protected bis-cyclen triazine **15** and a guanidine moiety, similar spacer molecules were chosen. But as two different binding sites needed to be coupled to the linker this could not be performed in one single step. Therefore it was

necessary to first introduce the guanidine and then afterwards couple it with the protected bis-cyclen triazines **15**.

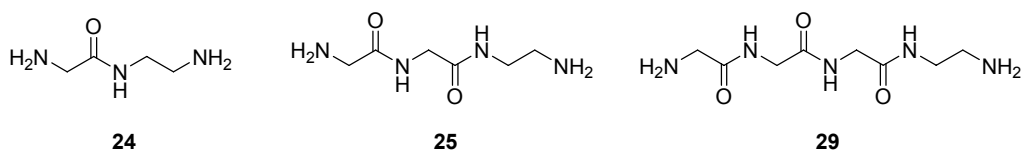

Figure 26: Spacer molecules.

3. Receptor Synthesis

The protected bis-cyclen triazine **15** can be easily synthesized in two steps starting from commercially available cyclen which is first threefold protected by the use of di-tert-butyl dicarbonate and afterwards is coupled to 2,4,6-trichloro-1,3,5-triazine with an over all yield of 80 %.¹⁰⁵

3.1. Synthesis of the Tetra(Zn(II)-Cyclen) Receptors

The reaction leading to the smallest receptor containing two bis(Zn(II)-cyclen) triazine moieties started with a substitution reaction in which two equivalents of the precursor **15** were brought to reaction with butane-1,4-diamine **23**. The reaction mixture was refluxed for three days and gave the product **30** in 67 % yield. In the following step the Boc-protecting groups were cleaved quantitatively with ice-cold HCl saturated diethyl ether. The resulting hydrochloride salt of the product was deprotonated over a strongly basic ion exchanger column. The obtained ligand was complexated using $\text{Zn}(\text{ClO}_4)_2 \cdot 6 \text{H}_2\text{O}$, giving the product **31** after recrystallization from a water/methanol mixture in 17 % yield.

Scheme 1: Synthesis of complex **31** containing two bis(Zn(II)-cyclen) triazine moieties.

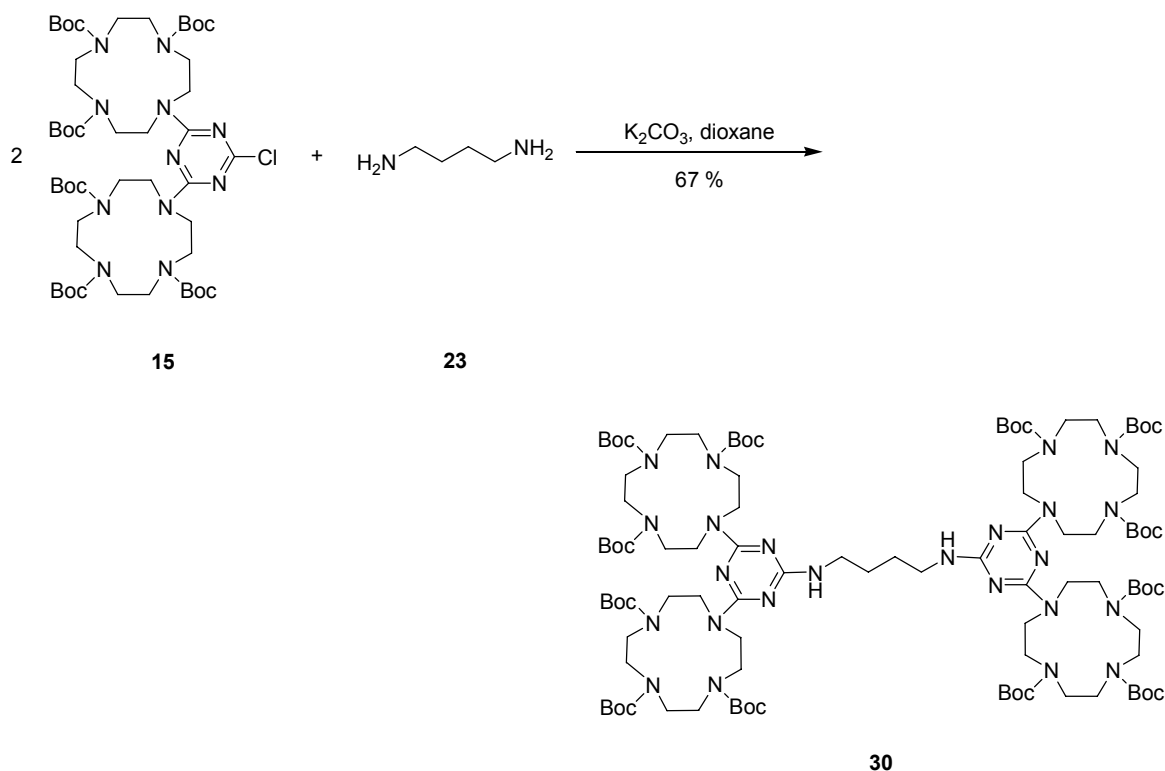

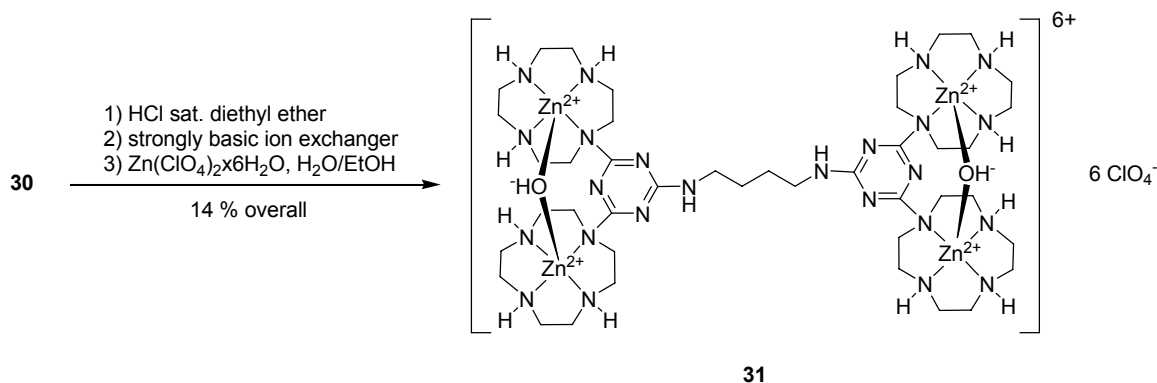

For the longer homologue of **31**, a spacer molecule was prepared from Boc-protected glycine **32** and mono Boc-protected ethylene diamine **33**. As coupling reagents for the peptide coupling reaction EDC and HOBt were used. The protected diamine was deprotected with ice-cold HCl saturated diethyl ether to give the hydrochloride salt **34** in 57 % yield over two steps. The salt **34** was used for the substitution reaction without further purification. Compound **35** was formed after three days of refluxing in dioxane in a yield of 67 %. After the protecting groups of compound **35** were cleaved, again by the use of ice-cold HCl saturated diethyl ether, the resulting hydrochloride salt was purified over a strongly basic ion exchange column. The resulting free amine was used in the complexation reaction together with $\text{Zn}(\text{ClO}_4)_2 \cdot 6 \text{ H}_2\text{O}$ to form the complex **36** in a yield of 14 % over three steps.

Scheme 2: Synthesis of the diamine **34** used as linker in the receptor **36**.

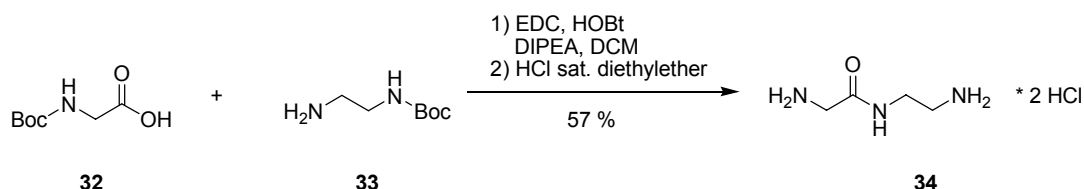

Scheme 3: Synthesis of complex **36** containing two bis(Zn(II)-cyclen) triazine moieties and the diamine **24** as linker.

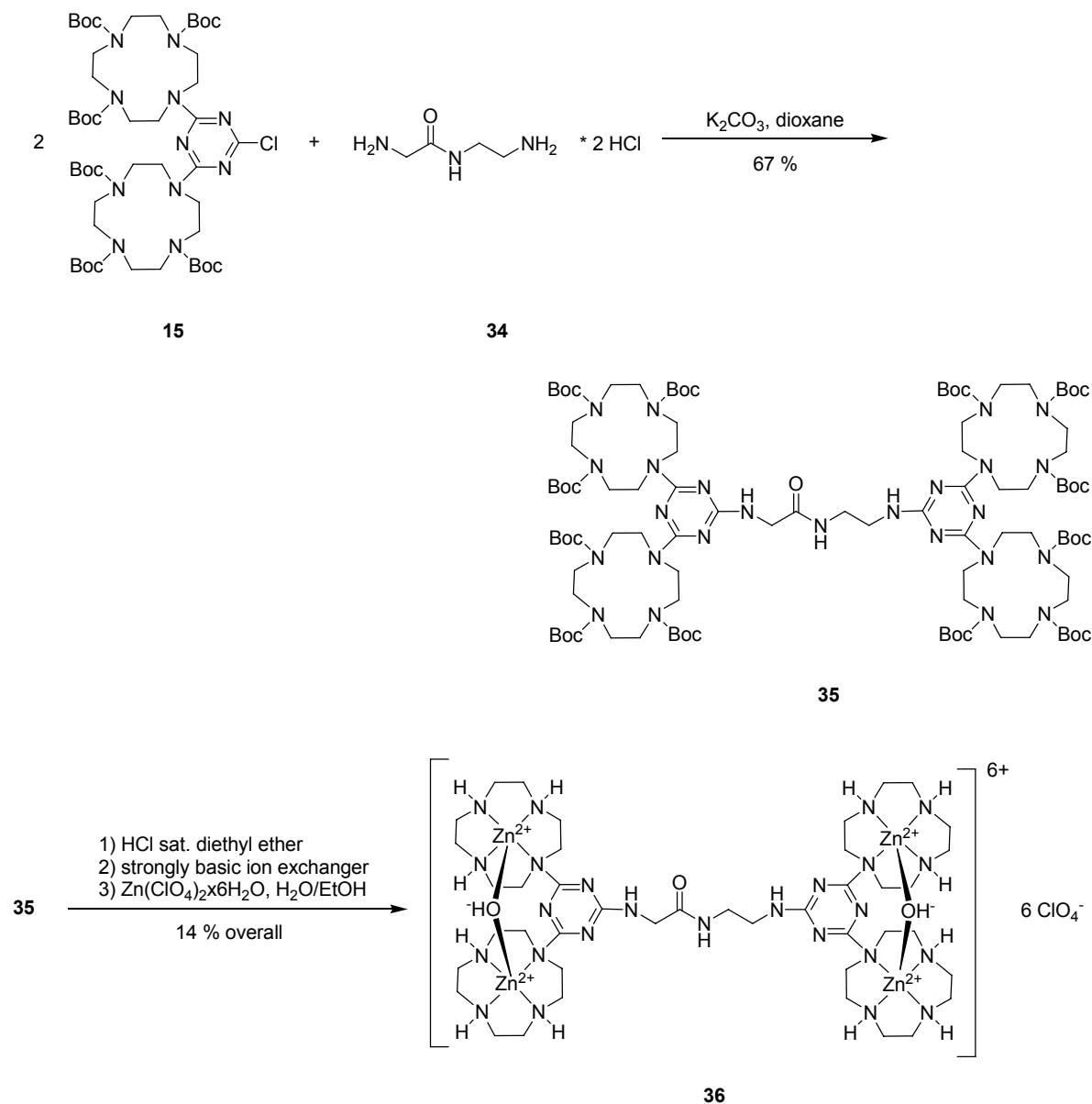

For the third and longest receptor with two bis(Zn(II)-cyclen) triazine moieties, the linker was prepared starting from Boc-protected glycine **32** which was coupled to glycine methyl ester hydrochloride **37** by the use of EDC and HOBT as coupling reagents. After the ester saponification using a 1M aqueous NaOH solution in combination with methanol as solvent, the resulting free acid **38** was used in a second peptide coupling reaction with Boc-protected ethylene diamine **33**. The resulting precursor was deprotected using ice-cold HCl saturated diethyl ether to give the hydrochloride salt **39**. This was then used directly without further purification for the formation of the fully protected receptor **40**. After cleavage of the protecting groups with HCl saturated diethyl ether and purification over a strongly basic ion exchange column the complexation was performed using Zn(ClO₄)₂ ·

6 H₂O. After recrystallization from a water/methanol mixture the pure complex **41** was obtained in 63 % yield over three steps.

Scheme 4: Synthesis of complex **41** containing two bis(Zn(II)-cyclen) triazine moieties and the diamine **25** as linker.

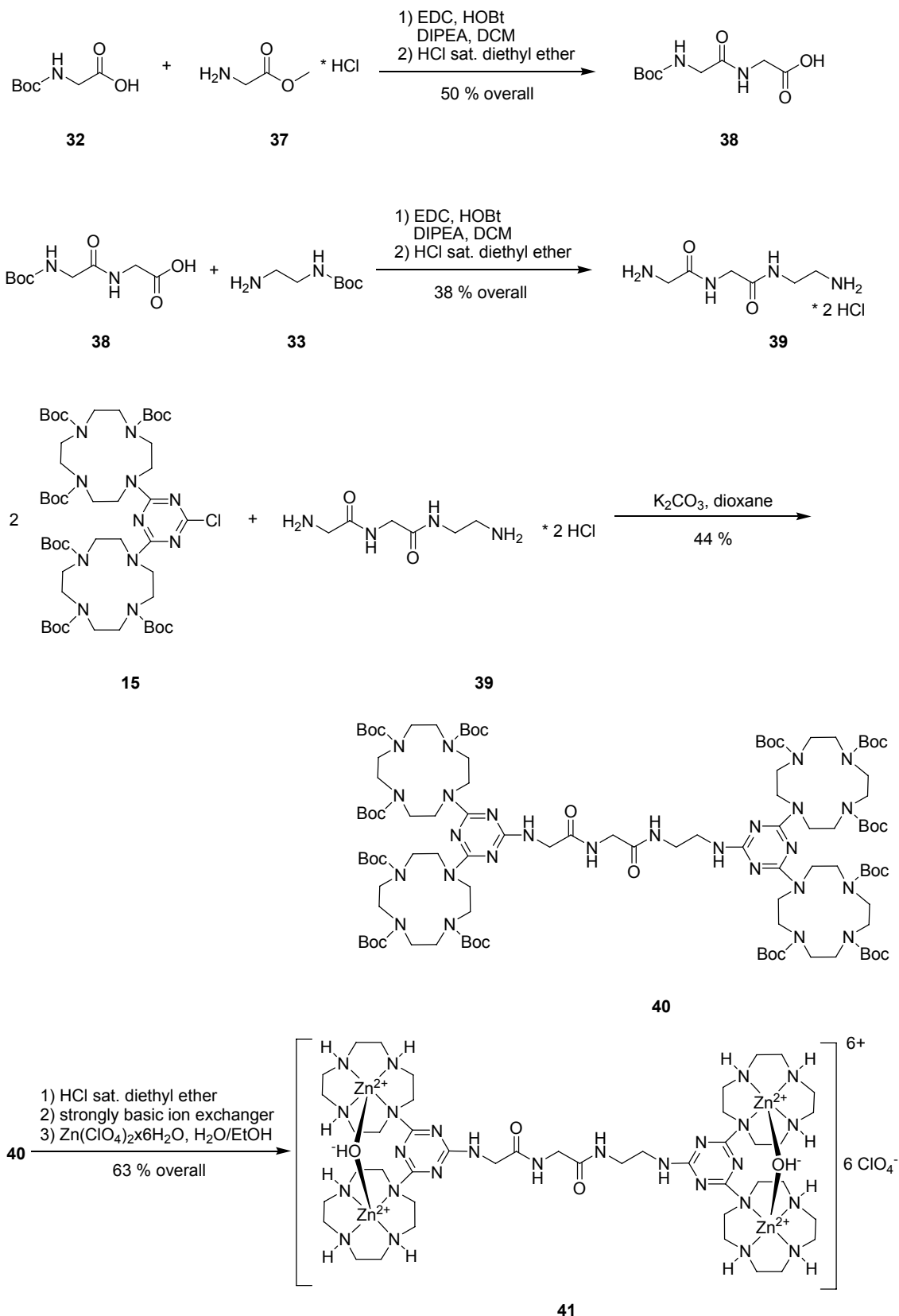

The synthesis of the fluorescently labeled receptor precursor **46** followed a similar pathway. The linker was prepared by a peptide coupling reaction of *N*-terminally Boc- and side chain Cbz-protected lysine **42** with Boc-protected diethyl amine **33** using EDC and

Scheme 5: Synthesis pathway leading to a dansyl labeled receptor precursor **46**.

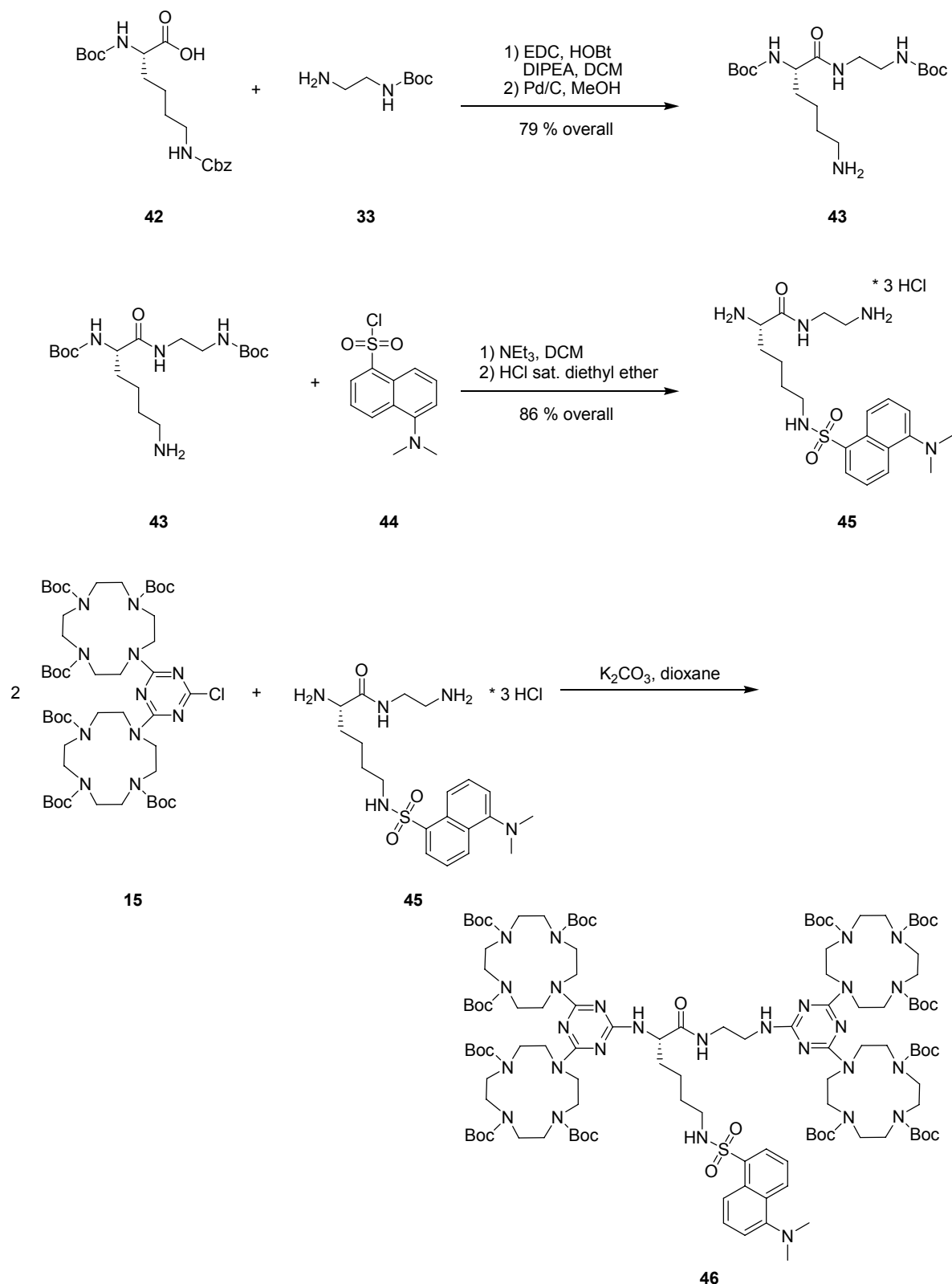

HOBt as reagents to activate the carboxylic acid **42**. The product was deprotected after purification using palladium on activated charcoal under an atmosphere of hydrogen. This gave compound **43** in a good yield of 79 % over two steps. The dansyl moiety was introduced in a substitution reaction by the use of dansyl chloride **44** and NEt_3 as organic base. The resulting yellow compound was Boc-deprotected, giving the linker **45** in 86 % yield and ready for the last substitution reaction. The following reaction, which should have provided the fully protected fluorescent precursor **46** of the desired complex unfortunately did not yield product in sufficient amounts. The reaction was tested in dioxane under reflux and also in DMF under reflux. In dioxane, traces of the desired product were formed but the main product was the mono substitution product. The same reaction in DMF showed only decomposition products.

One reason causing the reaction to fail could have been a change in reactivity of the diamine **45** caused by the dansyl unit, therefore the reaction was tried again with the still Cbz-protected diamine **48**. Unfortunately, this reaction also gave a mixture of different compounds with only traces of product **49**. This indicates that it is not the dansyl unit causing the substitution reaction to fail. However, the presence of the lysine side chain seems to change the reactivity of the linker in a way that the twofold substitution can not take place anymore.

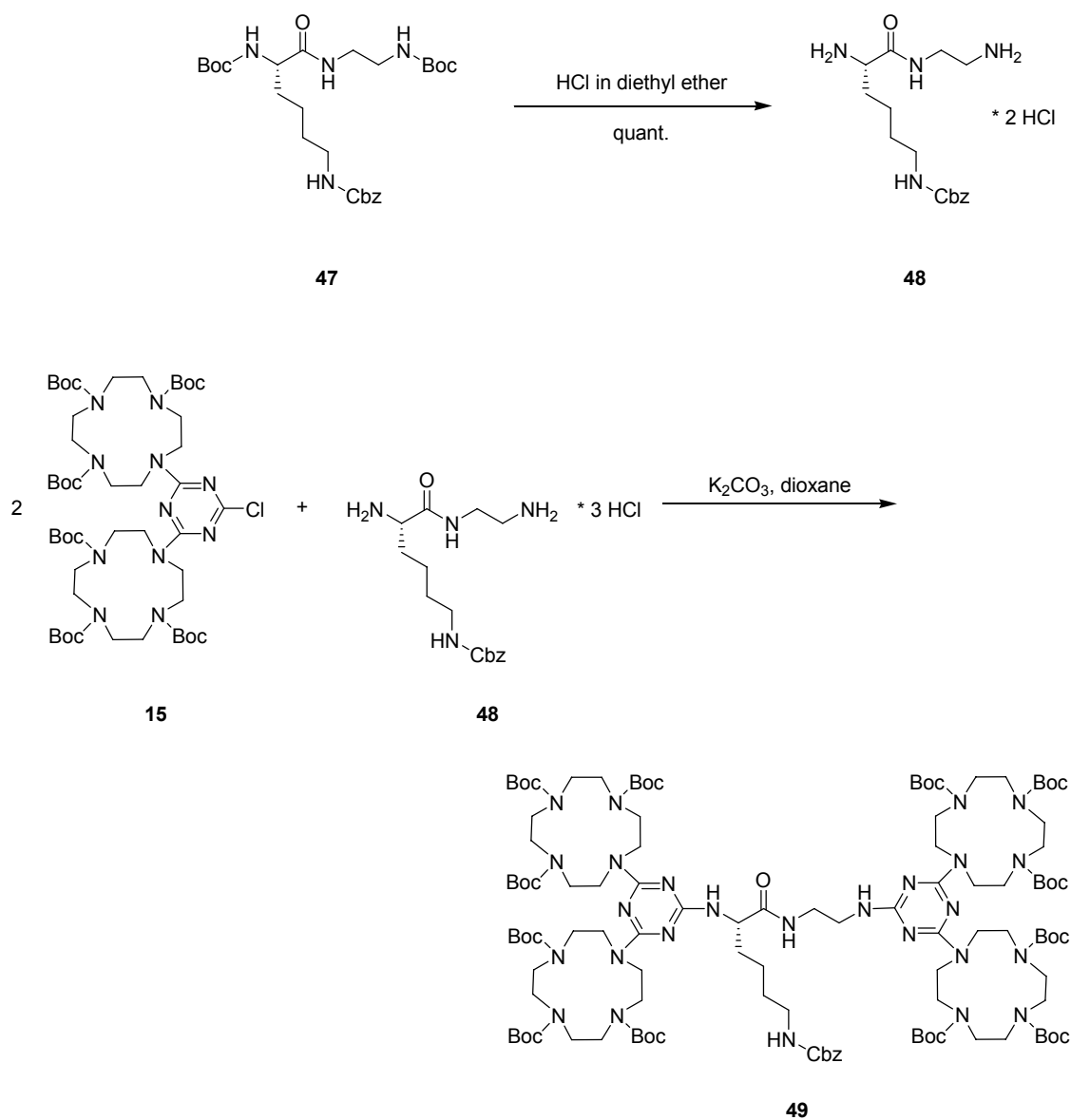
Scheme 6: Alternative synthesis pathway leading to the dansyl labeled receptor precursor **49**.

Due to the fact that the synthesis of the dansyl labeled lysine containing receptors proved to be difficult and also because of the poor fluorescence properties of the dansyl motif, namely the low quantum yield and also the short excitation wavelength λ_{ex} of about 337 nm. Therefore, it was decided to discontinue the synthesis of this kind of receptor. Further reasons were that with the compounds **55** and **56** presented in Chapter 3.2 fluorescently labeled receptors were available.

3.2. Synthesis of the Fluorescent Tetra(Zn(II)-Cyclen) Receptors

The precursor necessary for the formation of the diimides **53** and **54** was synthesized by a substitution reaction between the protected bis-cyclen triazine **15** and the previously prepared Cbz-protected diethyl amine **50**. The reaction carried out in dioxane under reflux gave the product after three days in 84 % yield.

Scheme 7: Synthesis of the precursor **52**.

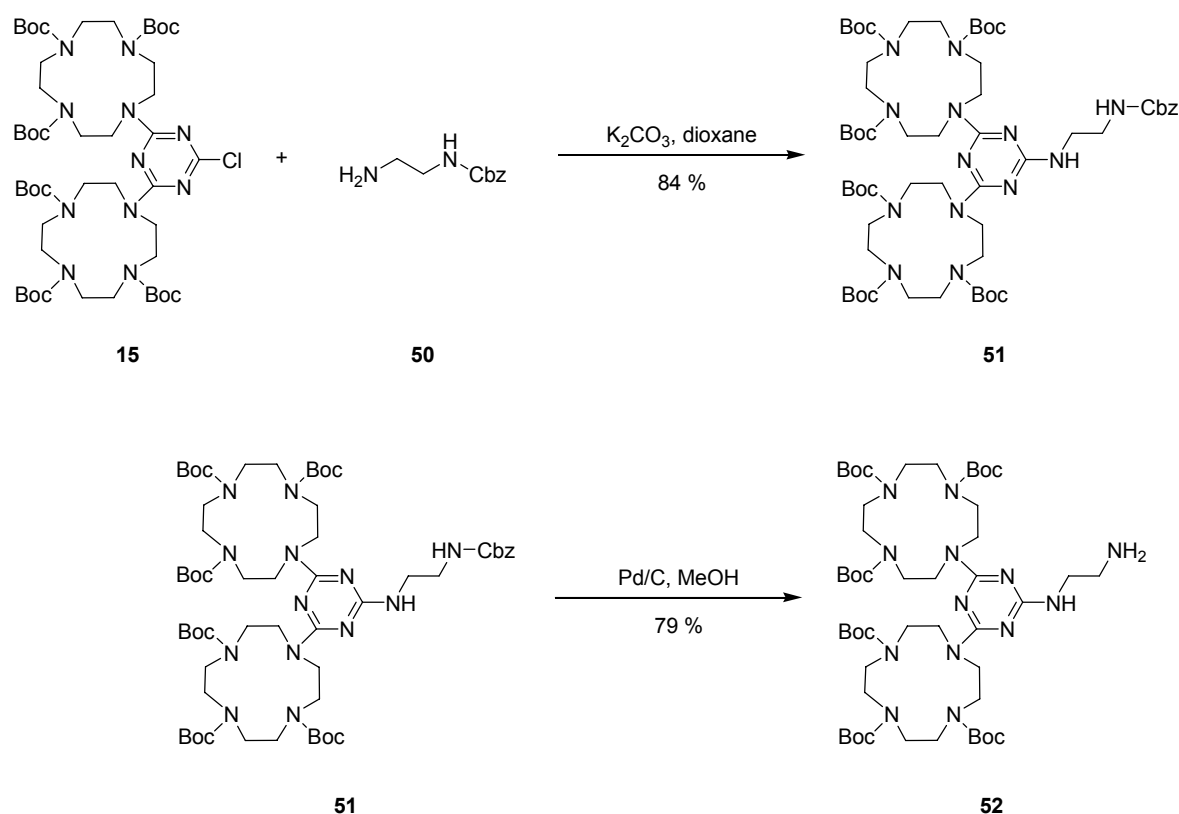

The cleavage of the Cbz group did not work under the normally applied conditions of palladium on activated charcoal as catalyst and stirring the mixture over night under 10 bar of hydrogen. The Cbz protecting group of this compound is more stable and can only be cleaved by 30 bar of hydrogen atmosphere and a reaction time of three days. Although this led to a partial decomposition, it still gave the product **52** in a good yield of 79 %.

To form the complex precursor **53**, one equivalent of naphthalene-1,4,5,8-tetracarboxylic dianhydride **27** was stirred together with 2.2 equivalents of **52** and DIPEA as base for 24 hours at 100 °C in toluene.¹⁰⁶ The product was formed in a yield of 94 % after column chromatography. The reaction giving the larger compound **54** proved to be more challenging than the one leading to compound **53**. The major difficulty was the extremely low solubility of the perylene-3,4,9,10-tetracarboxylic dianhydride **28** in nearly every solvent. A variety of organic solvents (methanol, DMSO, MeCN, toluene, dioxane) was

tested, but in all of them the dianhydride was not soluble enough to perform the reaction. In the end, a very unusual solution for the problem was found in literature.^{107, 108} It is possible to perform diimide formation reactions in an imidazole melt. To do so, the starting materials, in this case compound **52** and naphthalene-1,4,5,8-tetracarboxylic dianhydride **28**, were mixed with solid imidazole in a Schlenk tube. The mixture was then heated with a heat gun until the imidazole had completely melted and put into a hot oil bath preheated to 120 °C. The mixture was stirred with a conventional stirring bar for 24 hours. The addition of a base was not necessary due to the basicity of the imidazole. After the reaction was completed, the hot mixture was poured into water and extracted with ethyl acetate. Using this method, the imidazole remained in the aqueous phase and only the product **54** and some starting materials were extracted with the organic phase. This procedure gave the product **54** in 68 % yield.

Scheme 8: Synthesis of the protected receptor precursor **53**.

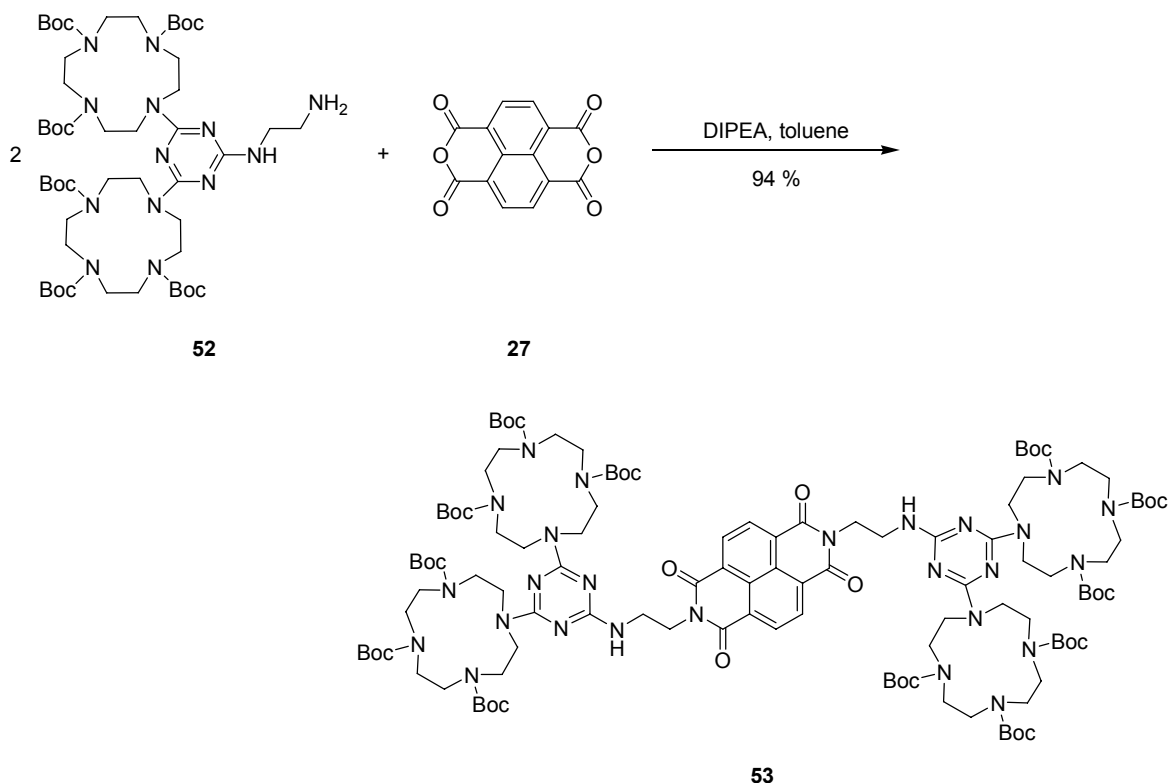

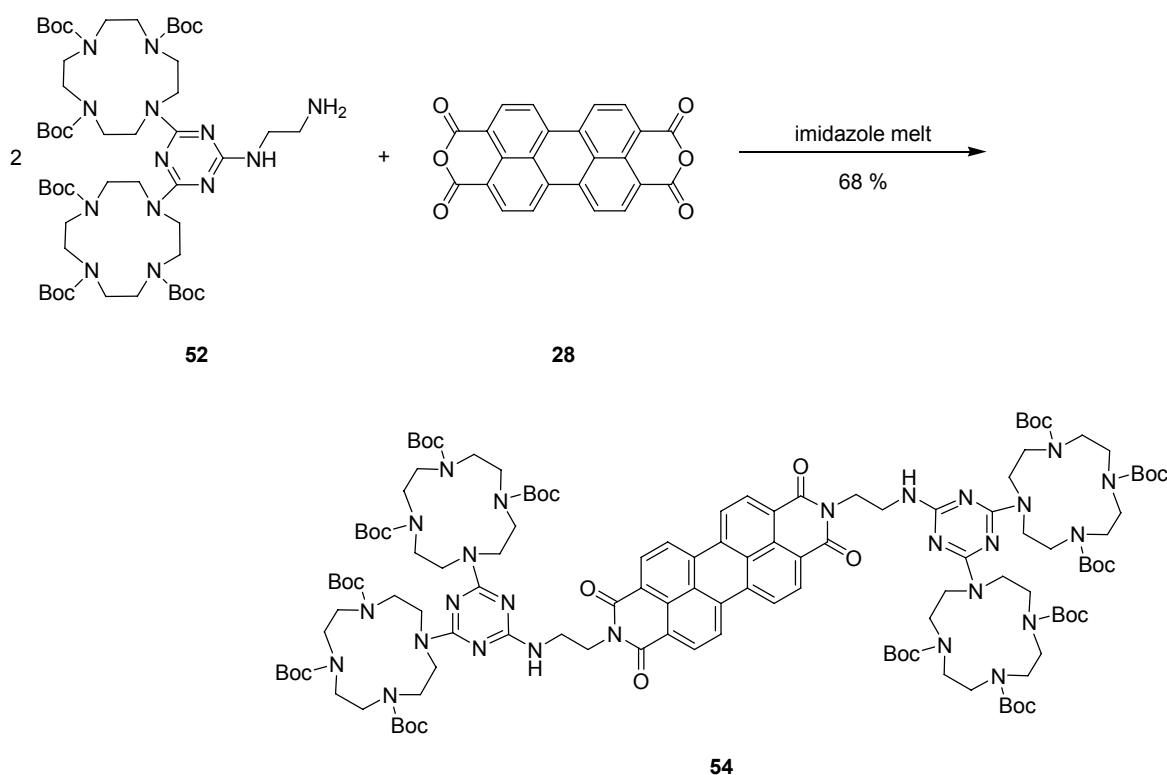
Scheme 9: Synthesis of the protected receptor precursor **54**.

Both receptor precursors **53** and **54** were analyzed for their UV and fluorescence properties. Both molecules show characteristic UV patterns with three maxima. For the smaller fluorophore the maxima occur at 338 nm, 356 nm and 376 nm. For the larger aromatic system, the maxima are red-shifted and appear at 456 nm, 484 nm and 521 nm.

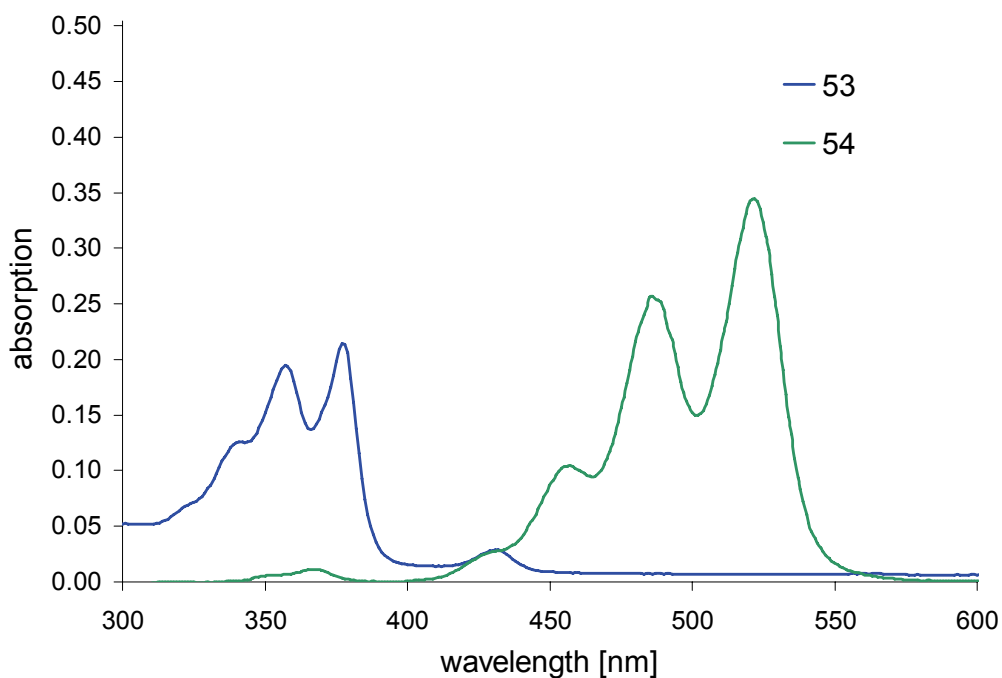

Figure 27: UV spectra of compounds **53** and **54** at a concentration of $1 \cdot 10^{-5}$ M in MeCN.

Additionally, the fluorescence properties of both compounds **53** and **54** were investigated, where it was found that only compound **54** is fluorescent. The smaller precursor **53** did not show any fluorescence. The reason could be some kind of intramolecular quenching due to a photoelectron transfer. Despite this, the synthesis of the complex **55** was performed in the hope that structural and electronical changes upon complexation might lead to a reappearance of the fluorescence.

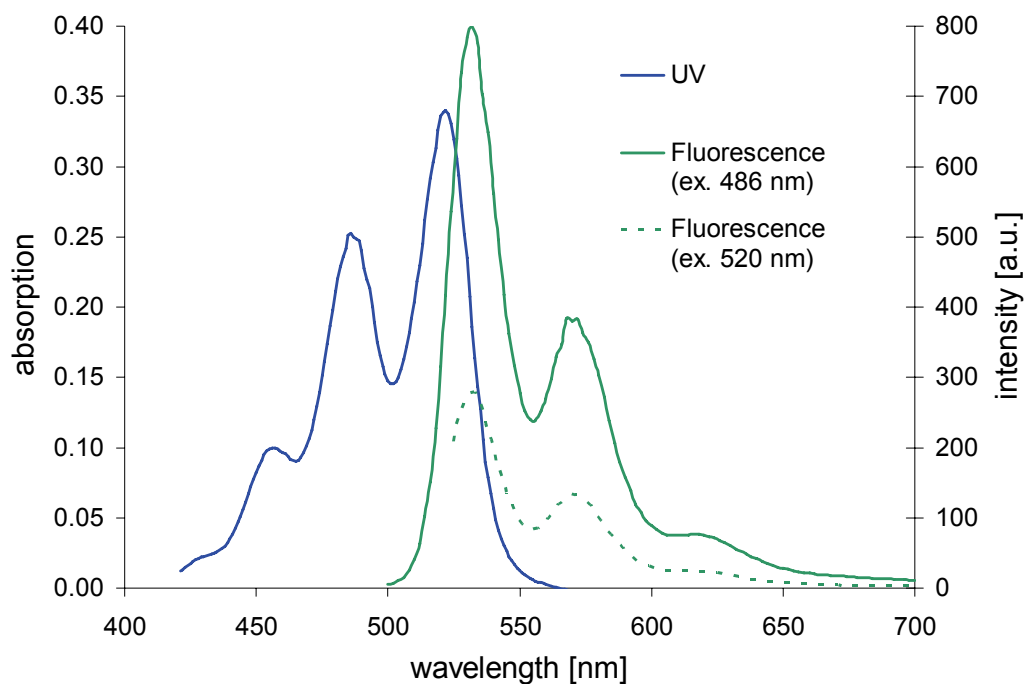

Figure 28: UV and fluorescence spectra of the protected receptor **54** at a concentration of $1 \cdot 10^{-5}$ M in MeCN.

The fluorescence of compound **54** was measured at two different excitation wavelengths of 486 nm and 520 nm. The emission maxima are at 532 and 570 nm. For measurements, the excitation at 486 nm is better suited than the one at 520 nm due to the higher emission intensity and because of the fact that the entire emission peak at 532 nm can be recorded. When exciting at the higher wavelength, the Stokes shift is so small that the first emission maximum can not be recorded entirely. Additionally, the quantum yield is lower for an excitation at 520 nm compared to an excitation at 486 nm resulting in a comparable lower fluorescence output of the system.

Perylene bisimide dyes and their derivatives are known to form stackings through their planar π -systems. This effect is well documented in crystal structures.^{109, 110} Only recently has the aggregation of these dyes also been studied in solution.¹¹¹ These π - π -aggregates could possibly create some artifacts in the binding assays of receptor **56** and the model peptides. It is possible to analyze the aggregation process by UV/Vis-spectroscopy. Therefore, concentration-dependent spectra of compound **54** were recorded in toluene in

a concentration range of 10^{-6} – 10^{-4} M. Indication for aggregation would be the appearance of red-shifted peaks in the UV/Vis-spectra with increasing concentration. The recorded spectra (see Figure 29) show no shift of the peaks at all, indicating that in the measured concentration range and below only the monomeric species of compound **54** exists. Above a concentration of 10^{-4} M, the absorption is so high that UV/Vis-spectroscopy cannot be used for a proper characterization of the aggregation properties.¹¹²

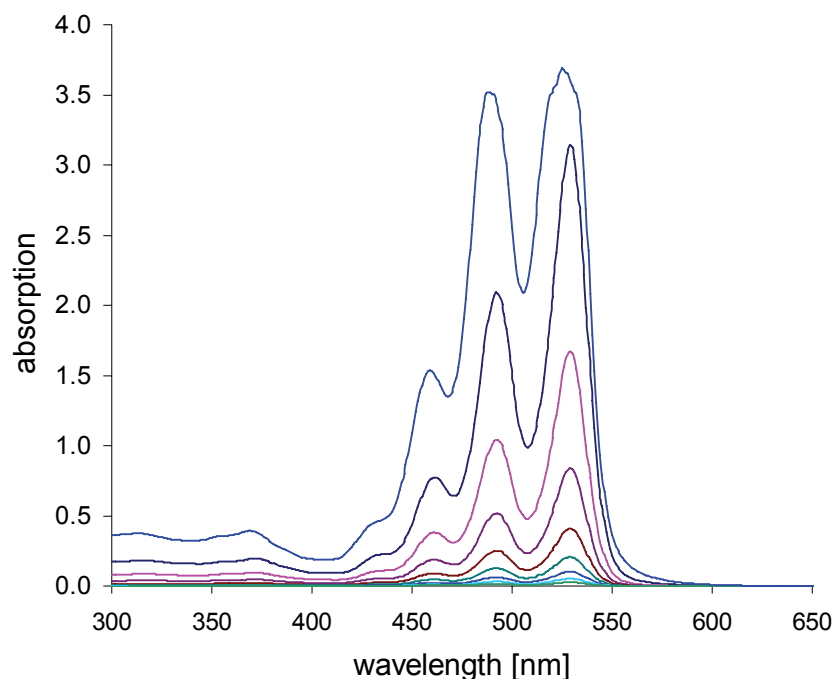

Figure 29: Concentration-dependent UV spectra of **54** in toluene recorded in a concentration range between $1 \cdot 10^{-4}$ and $1 \cdot 10^{-6}$ M.

However when different solutions in a concentration range of 10^{-7} – 10^{-2} M were excited on a UV-table at 316 nm, a marked shift in emission was observed (see Figure 30). With increasing concentration, the luminescence changes from green for the de-aggregated species to yellow, orange and even to red for the aggregated dyes.

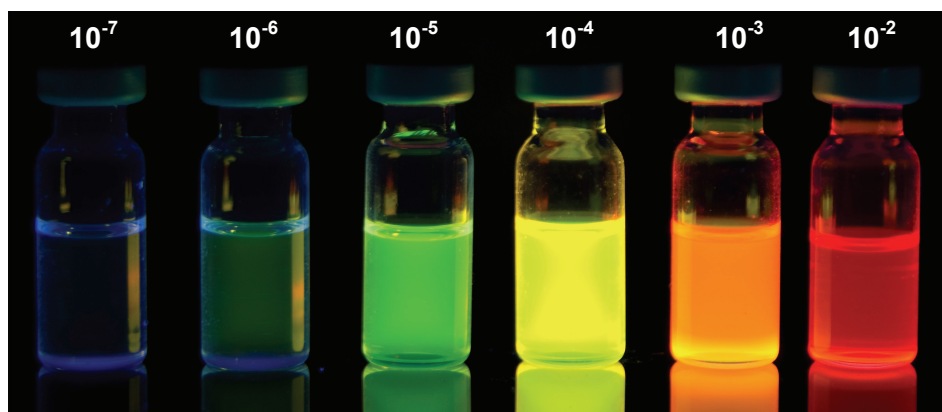
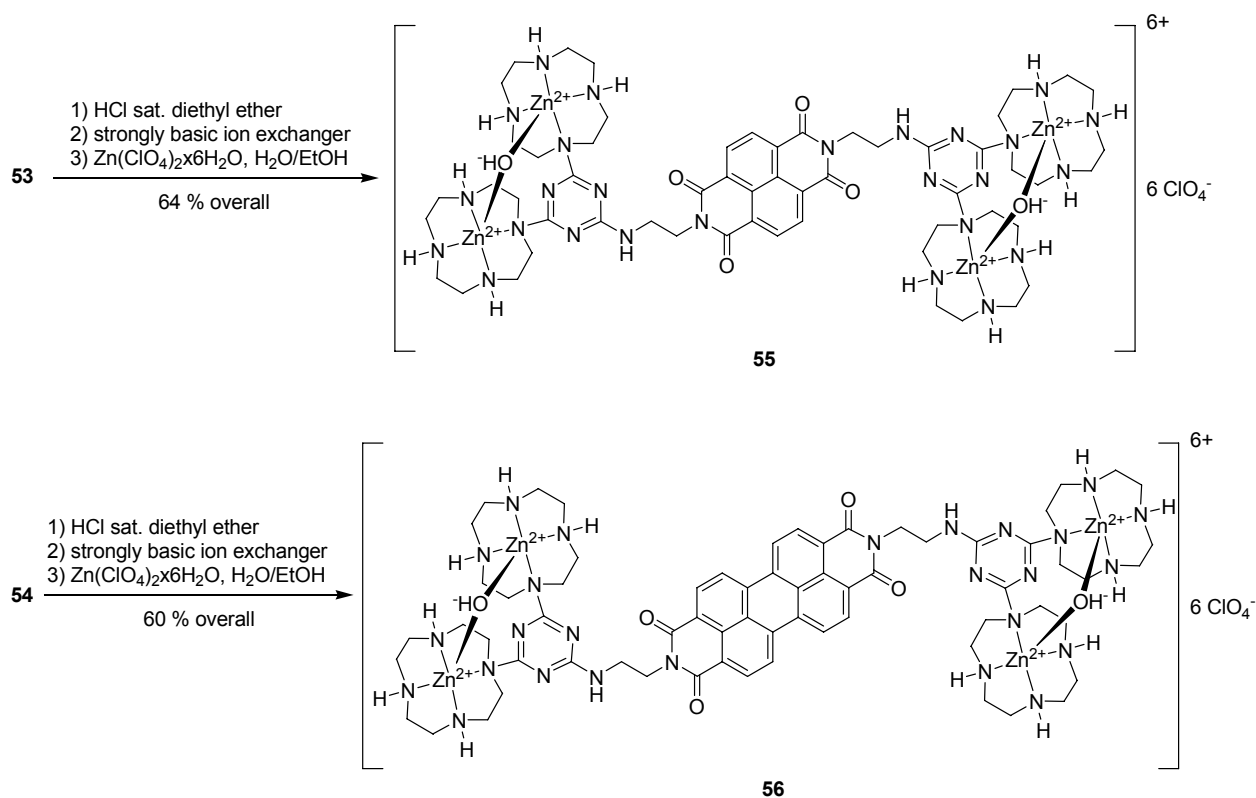

Figure 30: Concentration-dependent luminescence of **54** in toluene irradiated at 316 nm. The concentrations from left to right are: 10^{-7} , 10^{-6} , 10^{-5} , 10^{-4} , 10^{-3} , 10^{-2} M.

After the analysis of the spectral properties of compounds **53** and **54**, both were used for the synthesis of the metal complexes **55** and **56**. Accordingly, the protecting groups were cleaved with ice-cold HCl saturated diethyl ether the resulting HCl salts were purified over a strongly basic ion exchanger column followed by the complexation using $\text{Zn}(\text{ClO}_4)_2 \cdot 6 \text{H}_2\text{O}$. After recrystallization from a water/methanol mixture the pure complex **55** was obtained in 64 % yield over three steps and complex **56** was obtained in 60 % yield.

Scheme 10: Synthesis of the two Zn(II) complexes **55** and **56**.



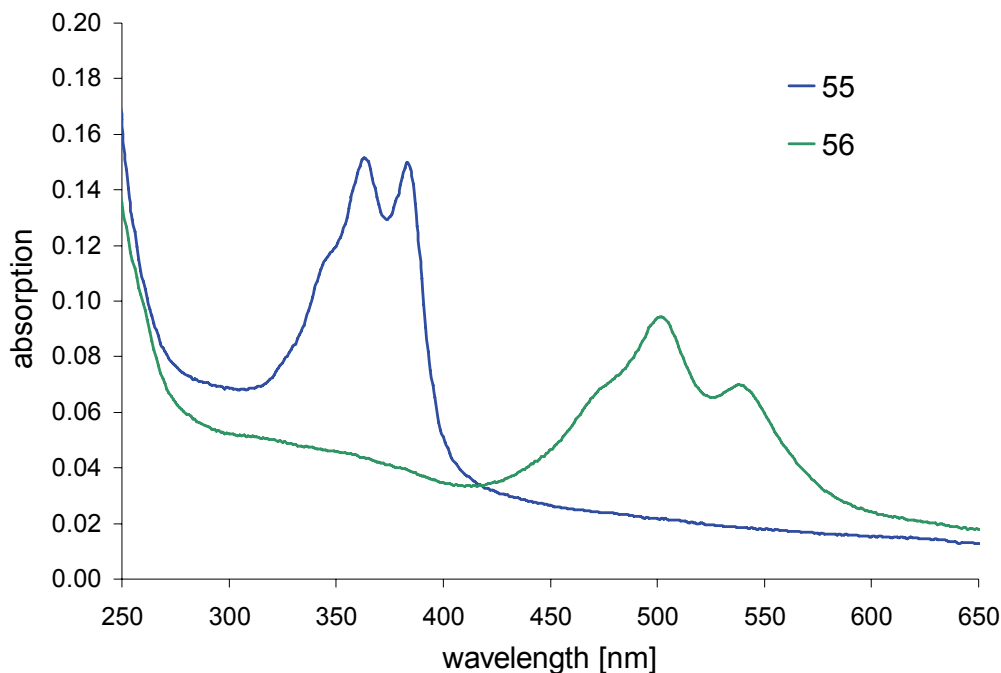

Figure 31: UV spectra of the metal complexes **55** and **56** at a concentration of $1 \cdot 10^{-5}$ M in HEPES buffered aqueous solution at pH 7.4.

The fluorescence spectra of the water-soluble perylene complex **56** was measured in HEPES pH 7.4 and displays qualitatively the same features as those found for the corresponding protected precursor **54**. The only differences are drastically decreased emission intensity and a red-shift of the whole spectrum showing now two peaks, at 550 nm and 594 nm. The fluorescence of compound **56** was measured at two different excitation wavelengths of 497 nm and 520 nm. Again, for measurements, the excitation at 497 nm is better suited than the one at 520 nm due to the higher emission and because of the fact that the whole emission spectra can be recorded.

Obviously, the metal complex **56** can also potentially aggregate at higher concentrations, which might lead to artifacts in the fluorescence titrations as explained before. But due to the previous results showing that there is no aggregation at concentrations below $1 \cdot 10^{-5}$ and $1 \cdot 10^{-6}$ M this is no problem for the binding assays because those titrations are carried out in a concentration range which is at least two orders of magnitude below the concentration necessary for an aggregation.

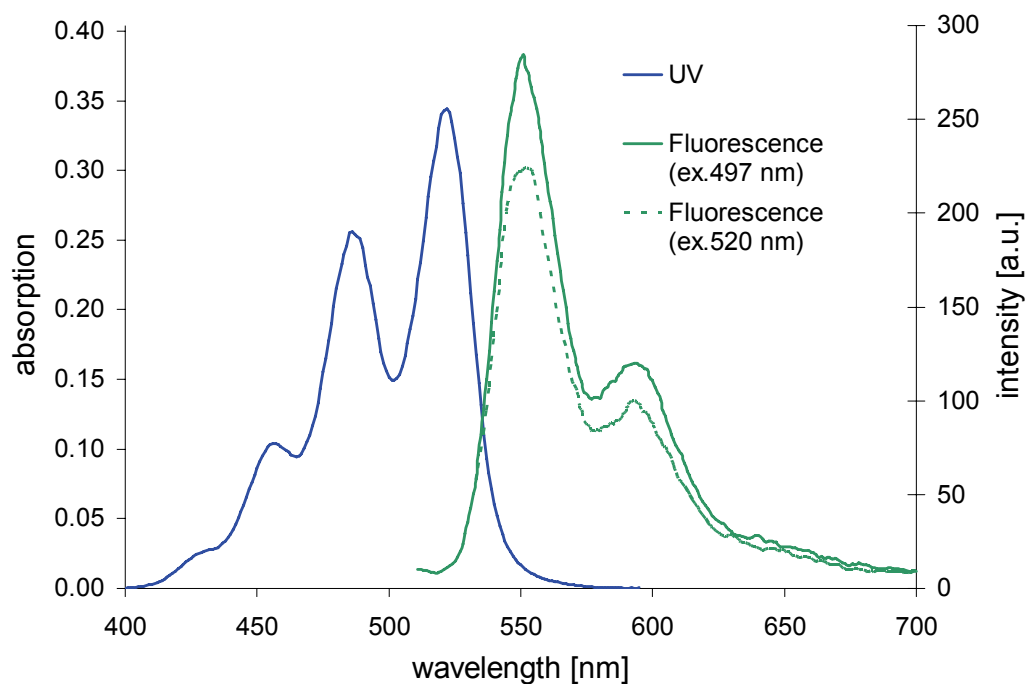

Figure 32: UV (blue) and fluorescence spectra (green) of the metal complex **56** at a concentration of $1 \cdot 10^{-5}$ M in HEPES buffered aqueous solution at pH 7.4.

Again, the smaller compound **55** did not show any fluorescence at a concentration of $1 \cdot 10^{-5}$ M or lower in water, thus making it unsuitable for binding studies with un-labeled peptides but still this rigid molecule could be used for the analysis of fluorescent peptides. However, the fact that compound **55** shows no fluorescence at all was very surprising, as similar complexes containing the naphthalene diimide were previously used as chemoselective sensors for phosphate esters.¹¹³

3.3. Synthesis of the Bis(Zn(II)-Cyclen)-Guanidine-Receptors

For the synthesis of compound **60**, *t*-butyl 2-aminoethylcarbamate **33** was used in a substitution reaction together with the commercially available Cbz-protected guanidine precursors **57**. After the coupling reaction, the Boc-group was removed by the use of ice-cold HCl saturated diethyl ether giving the salt **58** in a very good yield of 91 % over the two steps. In the following, a peptide coupling reaction using EDC and HOBT as coupling reagents was performed to link the amine **58** with Boc-Gly-OH **32**. Again, the Boc-group was cleaved and the salt **59** was obtained in very good yield (83 % over two steps). The amine **59** was now ready for the substitution reaction which should result in the Boc and Cbz protected precursor **60**. Unfortunately only decomposition products emerged from the reaction and the desired product was not obtained.

Scheme 11: Attempted synthesis of the protected precursor **60**.

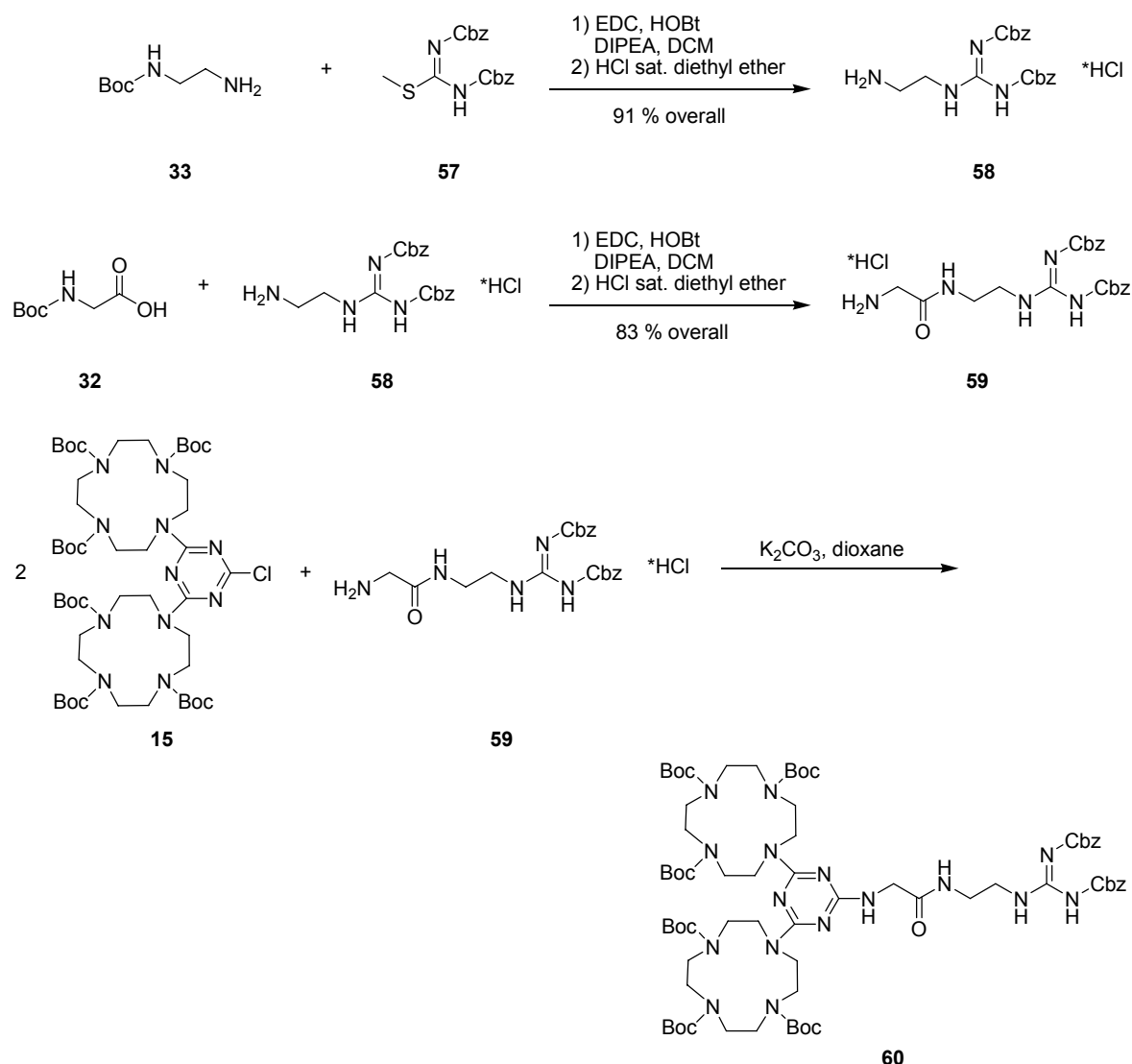

These results made a complete change in the reaction pathway necessary. As it was possible to obtain the ethylene diamine functionalized bis-cyclen triazine **52** in very good yields, it was decided to change the last step of the formation of the protected receptor precursor **60** from a substitution reaction to a peptide coupling reaction. This meant that the guanidine functionalized free acid **64** had to be synthesized which would then be coupled in the last step to the amine **52**. Because no Boc protecting groups would be needed during the synthesis of the guanidine acid **64**, the Cbz groups protecting the guanidine **57** were replaced by Boc groups to reduce the final deprotecting steps from two to one.

In the first step, S-methylisothiurea sulfate **61** was two-fold protected to give 1,3-bis(Boc)-2-methyl-2-thiopseudourea **63** in a yield of 98 % after column chromatography. The substitution reaction was performed with H-Gly-OMe **37** and after saponification of the methyl ester the acid **64** was obtained in good yield. The peptide coupling reaction gave the receptor precursor **65** in a yield of 25 % by the use of EDC and HOBt as coupling reagents. The precursor **65** was then Boc-deprotected with ice-cold HCl saturated diethyl ether, deprotonated over a strongly basic ion exchange column and afterwards used in the complexation reaction with $\text{Zn}(\text{ClO}_4)_2 \cdot 6 \text{H}_2\text{O}$ to give complex **66** in an overall yield of 63 %.

Scheme 12: Synthesis of the precursor **64**.

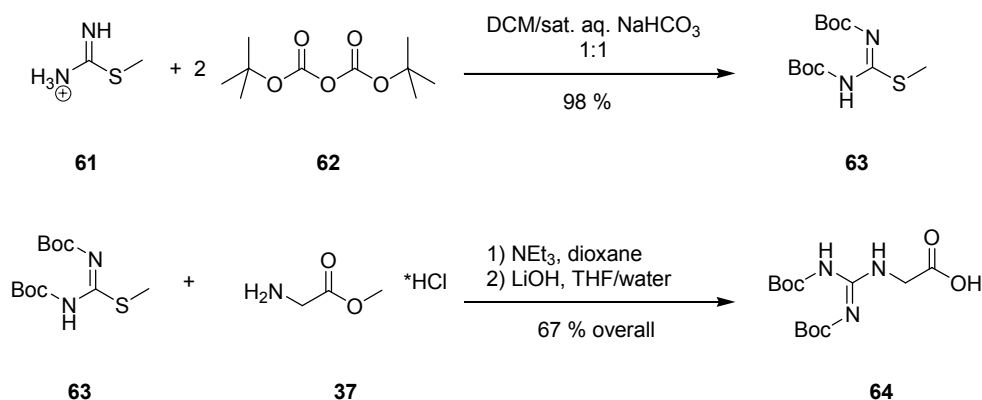

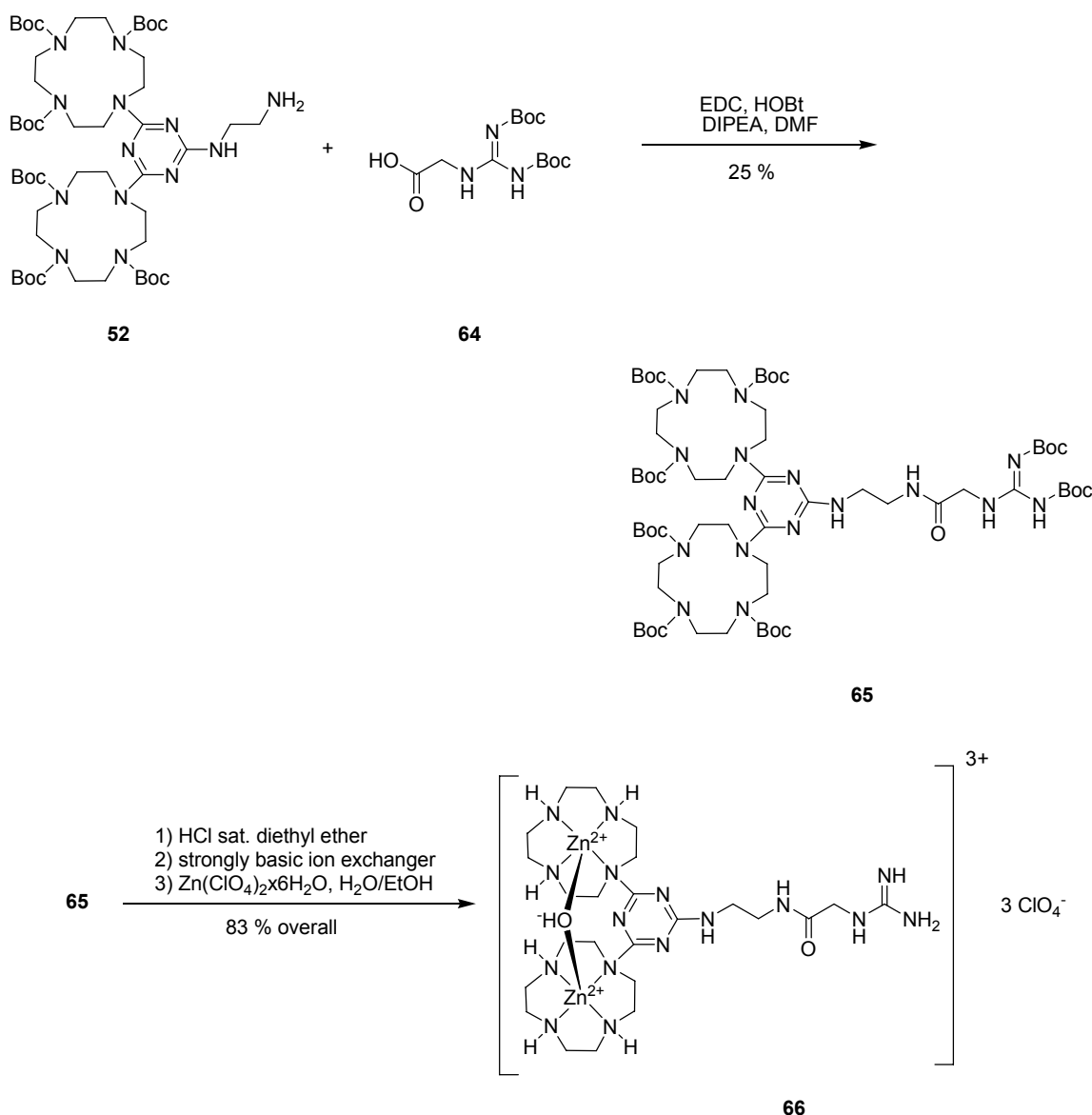
Scheme 13: Synthesis of complex **66**.

The receptor precursor **69** with the spacer **25** was synthesized in a similar way as compound **65** shown above. Glycylglycine methylester hydrochloride **67** was used for the substitution reaction at the compound **63**. After saponification of the resulting ester, the free acid **68** was obtained in 67 % yield over two steps. The following peptide coupling reaction gave the protected receptor precursor **69** in 23 % yield by the use of EDC and HOBT as coupling reagents. The precursor **69** was then Boc-deprotected with ice-cold HCl saturated diethyl ether, deprotonated over a strongly basic ion exchange column and afterwards used in the complexation reaction with $\text{Zn}(\text{ClO}_4)_2 \cdot 6 \text{H}_2\text{O}$ to give the complex **70** in an overall yield of 63 %.

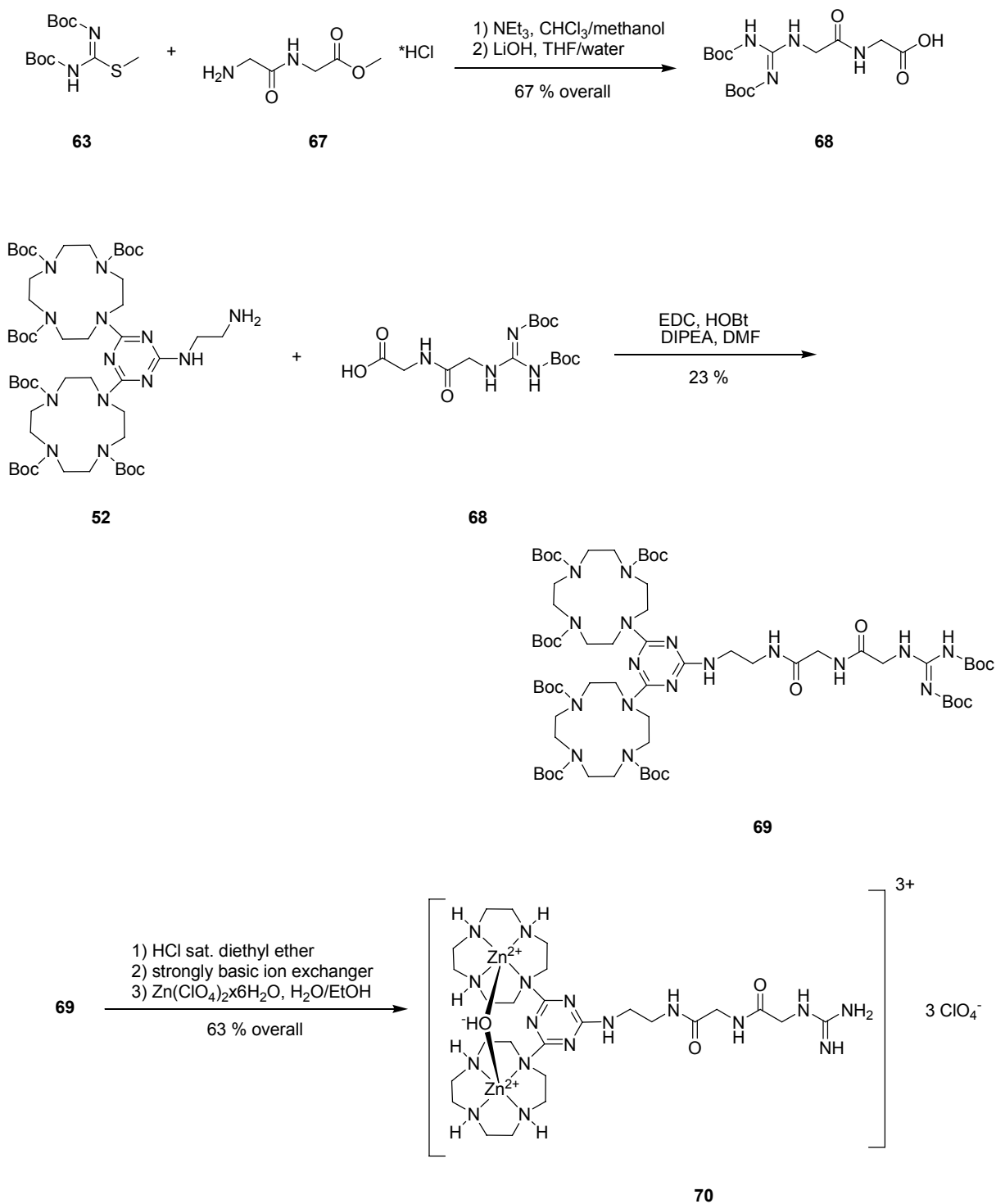
Scheme 14: Synthesis of complex **70**.

The receptor **74** containing a bis($\text{Zn}(\text{II})$ -cyclen) triazine and a guanidine moiety was synthesized like the receptors shown before. The glycine tripeptide methylester precursor **69** was coupled in a substitution reaction with compound **64** to give the free acid **72** after saponification of the methyl ester in 24% yield over the two steps. The following peptide coupling reaction gave the protected receptor precursor **73** in 50% yield by the use of

EDC and HOBt as coupling reagents. The precursor **73** was then Boc-protected with ice-cold HCl saturated diethyl ether, deprotonated over a strongly basic ion exchange column and afterwards used in the complexation reaction with $\text{Zn}(\text{ClO}_4)_2 \cdot 6 \text{H}_2\text{O}$ to give the complex **74** in a overall yield of 26 %.

Scheme 15: Synthesis of complex **74**.

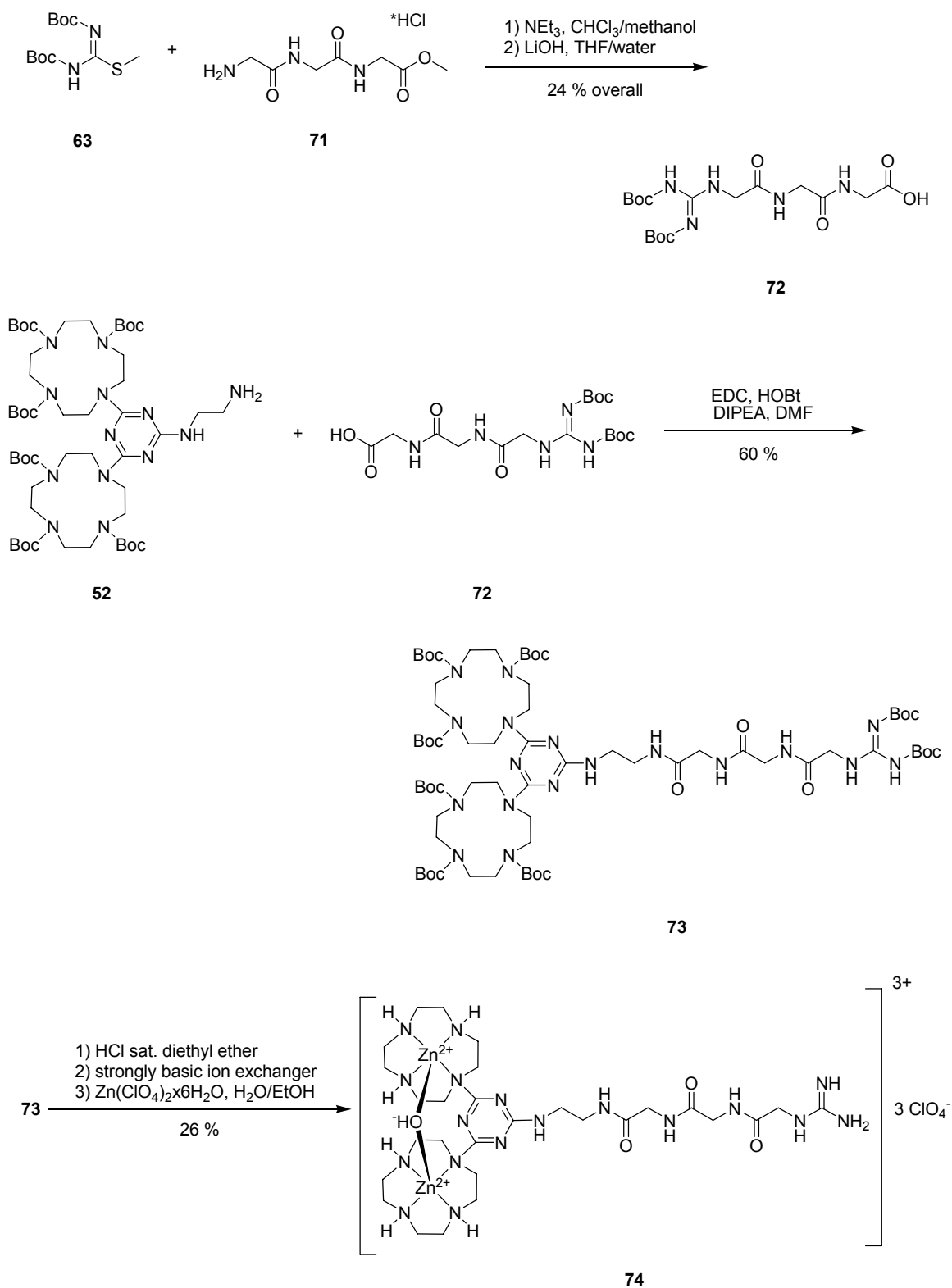

4. Binding Studies

In addition to the receptors **31**, **36**, **41**, **55**, **66**, **70** and **74**, the previously synthesized¹⁰⁴ receptors **75** – **78** were also used in different assays. Beside the bidentate receptors the complexes **80** and **81** which represent receptor substructures were also measured to derive information about the contribution of the second binding site to the affinity of the receptors.

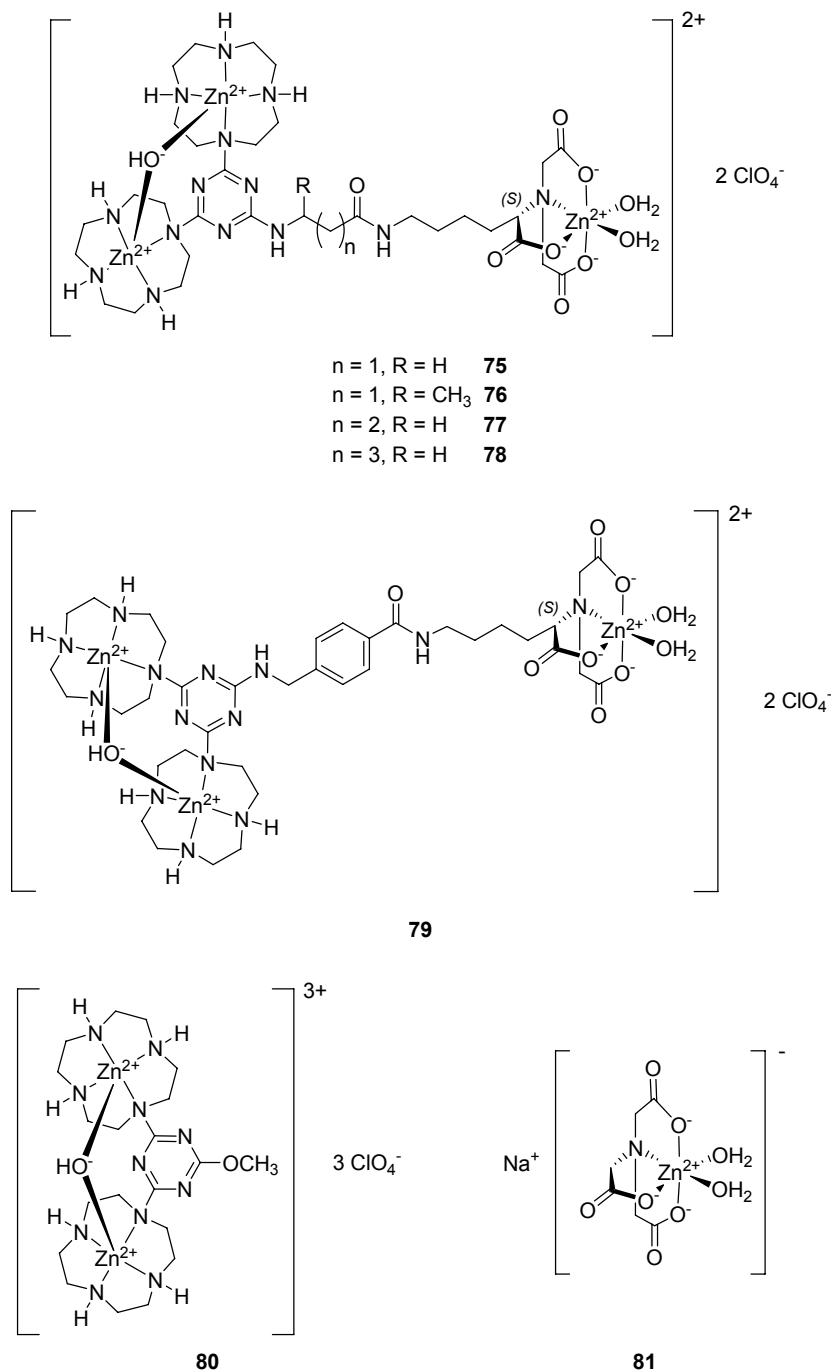

Figure 33: Bis(Zn(II)-cyclen) triazine Zn(II)-NTA complexes **75** – **78** and complexes **80** and **81** representing receptor substructures.

4.1. Binding Affinities Towards Different STAT Proteins

4.1.1. Binding Assay

The group of *T. Berg* has developed a high-throughput fluorescence polarization assay which allows the screening of small molecules that can bind to the STAT SH2 domain and thereby inhibit its activity. This assay is based on the binding of small fluorescein-labeled phosphotyrosine-peptides to unphosphorylated STAT. In nature, the unphosphorylated STAT binds to kinases and is then phosphorylated by them. This tyrosine phosphorylation of STATs induces dimerisation and with that activates the STAT. If the binding of STAT to the kinase is inhibited, the activity of the STAT is blocked.

The developed polarization assay is based on this interaction. At first, an unphosphorylated STAT is incubated with a short fluorescein-labeled phospho-peptide (such as peptides **P1** – **P5**) with a sequence derived from the active site of kinases known to interact with the STAT. A small molecule inhibitor can displace the peptide bound to STAT protein. The bound peptide exhibits a decrease in fluorescence polarization due to its significantly reduced molecular mass.¹¹⁴

4.1.2. Binding Results and Discussion

The binding affinities of receptors **66**, **70**, **74** and **77** – **79** towards the different peptides **P1**, **P2** and **P3** were investigated.¹

- a) 5-Carboxyfluorescein–Gly-pTyr-Asp-Lys-Pro-His-Val-Leu-OH (P1)
- b) 5-Carboxyfluorescein–Gly-Phe-Asp-pThr-Tyr-Leu-Ile-Arg-Arg-OH (P2)
- c) 5-Carboxyfluorescein–Gly-pTyr-Glu-Glu-Ile-Pro-OH (P3)

The complexes **66**, **70**, **74** and **77** – **79** are potential receptors for the peptides because all have a phosphorylated amino acid side chain (pTyr or pThr) and an aspartic or glutamic acid as a second binding motif in their sequence.

¹ Peptides were synthesized by Dr. F. Freudenmann. Binding investigations were performed by Bianca Sperl under the supervision of Dr. Thorsten Berg (Max Planck Institute of Biochemistry, Martinsried).

4.1.2.1. Inhibitory Effect Against the P1-STAT1-Complex

The influence of the metal complexes **66**, **70**, **77** – **79** on the binding between **P1** and STAT1 was investigated by the detection of the fluorescence polarization change of the system upon addition of the receptors. The diagram in Figure 34 shows the dependence of the peptide – protein binding on the concentration of added receptor. (The y-axis shows the ratio of **P1**-STAT1-complex in %, the x-axis the receptor concentration in μM) As a reference, the receptor substructure complex **80** was used for all measurements. The influence of this receptor (**80**) should appear at higher concentrations when compared to the other receptors as it consists of only one binding site and should therefore have a lower affinity. All measurements were conducted in duplicates under the same conditions

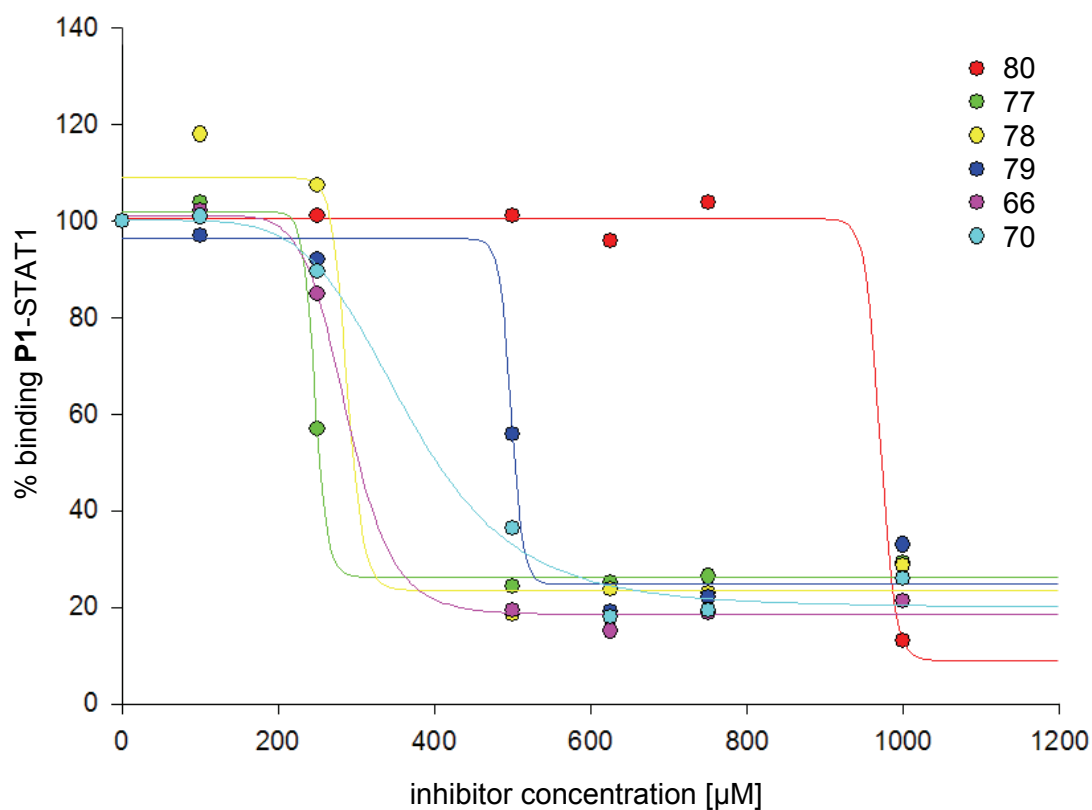

Figure 34: Titration curves of receptors **66**, **70**, **77** – **79** and the reference compound **80** in the fluorescence polarization assay with the **P1**-STAT1-complex.

The measurements revealed that receptors **66**, **77** and **78** have an influence on the **P1**-STAT1 binding at a concentration of about 300 μM while slightly higher concentrations of receptors **70** and **79** are needed to show the same effect (400 μM and 500 μM , respectively). The reference compound **80** inhibits the complex formation at a concentration of nearly 1 mM. These results indicate that the structure of the complexes has little influence on their inhibitory effect. Only the two largest compounds **70** and **79** of each group are slightly less active than their smaller homologues.

The results show that all bidentate receptors have an increased inhibitory effect when compared to the monodentate substructure **80**. The complexes **66**, **77** and **78** show the same effect at a threefold lower concentration while the complexes **70** and **79** do so at half the inhibitory concentration of **80**. This shows that the synthetic receptors with two binding sites have a higher affinity to the target peptide in the competitive binding than the one with only one binding site. However, the kind of the second binding site is not decisive, as comparable results were obtained regardless of whether the second binding site is a guanidine moiety (receptors **66** and **70**) or a Zn(II)-NTA complex (receptors **77** – **79**).

4.1.2.2. Inhibitory Effect Against the **P2**-STAT3-Complex

Additionally, titration experiments with the peptide-protein complex **P2**-STAT3 were performed. Nearly the same results as for the **P1**-STAT1 inhibition were obtained in these experiments. The bidentate receptors showed an influence on the **P2**-STAT3 binding at an inhibitor concentration of 300 - 400 μM while a slightly higher concentration of receptor **80** was needed to result in the same effect (600 μM).

As before, the length and also the kind of the second binding site of the receptors did not play an important role for the activity of the receptors. The bidentate receptors have an increased inhibitory effect being active at half of the inhibitory concentration when compared to the monodentate substructure **80**. Interestingly, when comparing peptide **P1** to peptide **P2**, the inhibitor concentration necessary for an influence on the **P2**-STAT3 binding when using receptors **66**, **70**, and **77** – **79** is nearly the same while for the complex **80** the concentration is reduced from about 1000 μM for the **P1**-STAT1-complex to 600 μM for the **P2**-STAT3-complex.

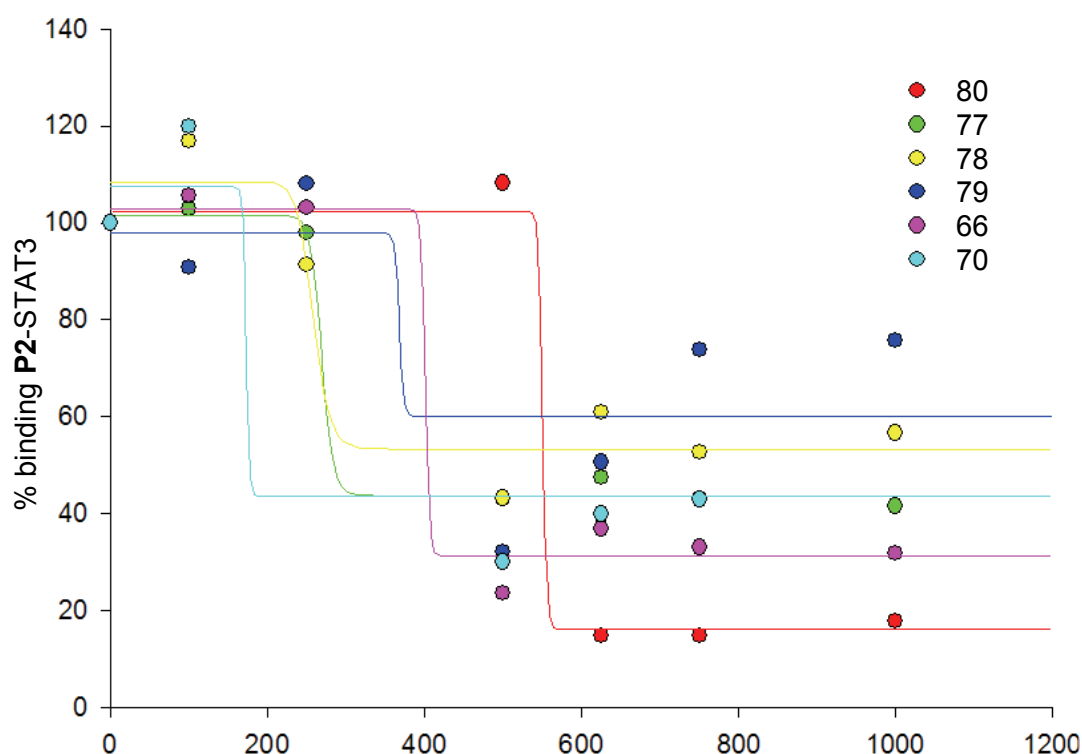

Figure 35: Titration curves of receptors **66**, **70**, **77 – 79** and the reference compound **80** in the fluorescence polarization assay with the **P2-STAT3**-complex.

4.1.2.3. Inhibitory Effect Against the **P3-Gst-Lck-Complex**

The titration experiments with the bidentate ligands **66**, **70**, **74** and the reference complex **80** with the **P3-GST-Lck**-complex were performed in analogy to the systems shown before. In contrast to peptides **P1** and **P2**, **P3** bears two carboxyl side chain functionalities in close proximity to the phosphorylated amino acid. Therefore it was expected to be a good binding partner for the receptors containing the bis(Zn(II)-cyclen) triazine complex and the guanidinium moiety. However, the measurements revealed almost no difference between the bidentate inhibitors **66**, **70** and **74** and the reference complex **80**. The concentrations of all complexes at 50 % of the **P3-GST-Lck**-complex were found to be in the range of 500 – 600 μM . This indicates that only one binding moiety of the bidentate receptors **66**, **70** and **74** can interact with the **P3-GST-Lck**-complex. Therefore they show the same inhibitory effect as the reference compound **80**.

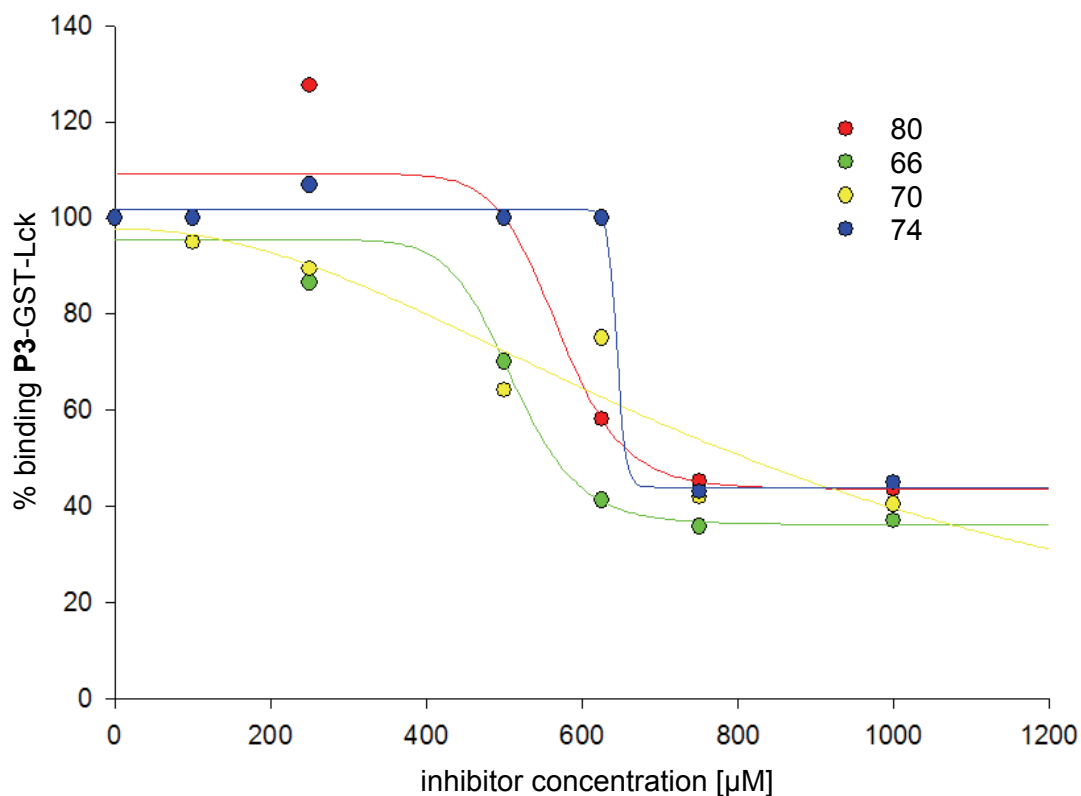

Figure 36: Titration curves of receptors **66**, **70**, **74** and the reference compound **80** in the fluorescence polarization assay with the **P3-GST-Lck**-complex.

4.1.2.4. Summary

In conclusion the results of the titration experiments showed that the bidentate receptors **66**, **70** and **77 – 79** show an insignificantly higher inhibitory effect than the reference compound **80**, at least for the peptide protein complexes **P1-STAT1** and **P2-STAT3**. For the **P3-GST-Lck**-complex this is not the case. Further, no relationship between the structure of the receptor and the binding affinity could be determined.

Because these indirect measurements based on the influence of the metal complexes on the inhibition of the interaction between the short fluorescein-labeled peptides **P1 - P3** with their natural partners (STAT1, STAT3 and GST-Lck) were not entirely successful, it was decided to determine the affinity of the metal complexes towards different peptides directly through fluorescence measurements.

4.2. Binding Affinities Towards the Peptides P7 and P8

Because the ditopic receptors used in the STAT assay did not show a significantly increased activity when compared to the receptor substructure complex **80** and also because the results from the inhibitor assay showed a high deviation and a bad reproducibility, it was decided to determine the binding of complexes **31**, **36**, **41**, **55**, **66**, **70** and **74 – 79** towards peptides with two side chain functionalities. As target peptides, the molecules **P7** and **P8** were selected in analogy to sequences of the human STAT proteins and prepared by standard solid-phase peptide synthesis. The peptides were *N*-terminally labeled with 5/6-carboxyfluorescein to allow the measurement of the binding constants by fluorescence emission and fluorescence polarization spectroscopy.²

- a) 5/6-Carboxyfluorescein–Gly–pSer–Ala–Ala–His–Val–NH₂ (P7)
- b) 5/6-Carboxyfluorescein–Gly–pSer–Ala–Ala–Glu–Val–NH₂ (P8)

The two potential binding sites of peptide **P7** are a phosphorylated serine and a histidine. Therefore the receptors **31**, **36**, **41** and **55** comprising of two bis(Zn(II)-cyclen) triazine complexes should show a higher affinity towards **P7** than towards **P8** which, with its pSer, presents only one possible binding site for the receptors **31**, **36**, **41** and **55**. In contrast the receptors **66**, **70** and **74** consisting of one bis(Zn(II)-cyclen) and a guanidinium moiety should show a higher affinity towards peptide **P8** with its two possible binding sites, namely the pSer and the glutamic acid. Like receptors **66**, **70** and **74** also receptors **75 – 79** bearing one bis(Zn(II)-cyclen) triazine and one Zn(II)-NTA complex should bind peptide **P8** with a higher binding constant than peptide **P7**.

4.2.1. Binding Assay

All binding studies were conducted in buffered aqueous solution (50 mM HEPES buffer, pH 7.5, 154 mM NaCl) with an excitation wavelength of $\lambda_{\text{ex}} = 494$ nm at a constant temperature of 298 K. A Varian Cary Eclipse fluorometer was used for the emission titrations. The cuvette with peptide **P7** or **P8** in HEPES buffer was titrated stepwise with small amounts (beginning with 0.13 eq) of the receptor solution. After each addition the solution was allowed to equilibrate for 2 min before the fluorescence intensity and the UV

² The synthesis of peptides **P7** and **P8** and the binding investigations were performed by Alexander Riechers under the supervision of Prof. Dr. Burkhard König (Institute of Organic Chemistry, University of Regensburg, Regensburg).

spectrum (where permitted by the concentration range) were recorded. The stoichiometries were determined by Job's plots calculated from the titration data. To determine the binding constants, the obtained fluorescence intensities at 520 nm were volume corrected, plotted against the concentration of receptor and evaluated by nonlinear fitting.

Fluorescence polarization titrations were conducted under identical conditions using an ISS K2 Multifrequency Phase Fluorometer.

4.2.2. Binding Results

Fluorescence titration results of the receptors **31**, **36**, **41**, **55**, **66**, **70**, **74** – **79** and the receptor substructures **80** and **81** against the test peptides **P7** (shown on the left) and **P8** (shown on the right) are printed below in Figure 37 - Figure 50. The blue and red dashed lines represent the measured data while the solid black lines represent the non linear fitting of the data.

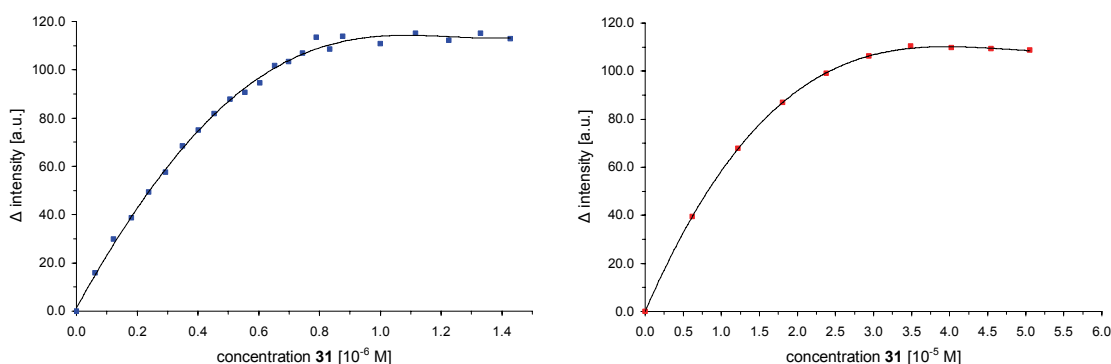

Figure 37: Emission titrations of receptor **31** against peptides **P7** (left) and **P8** (right).

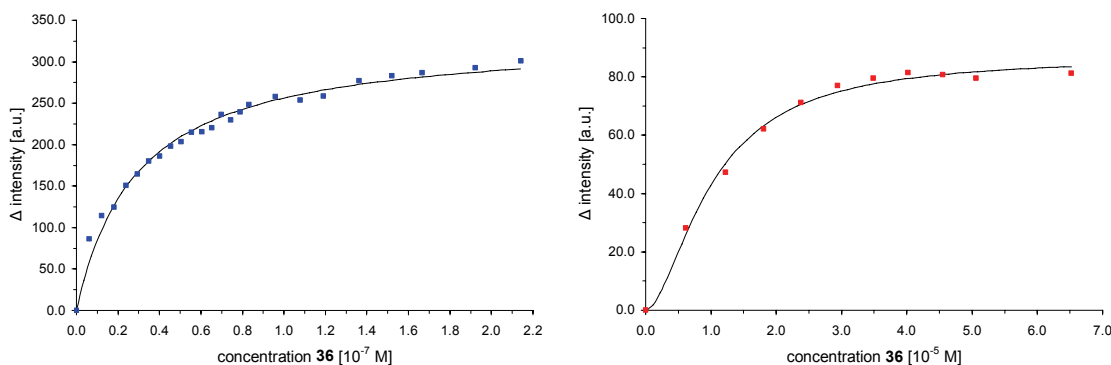

Figure 38: Emission titrations of receptor **36** against peptides **P7** (left) and **P8** (right).

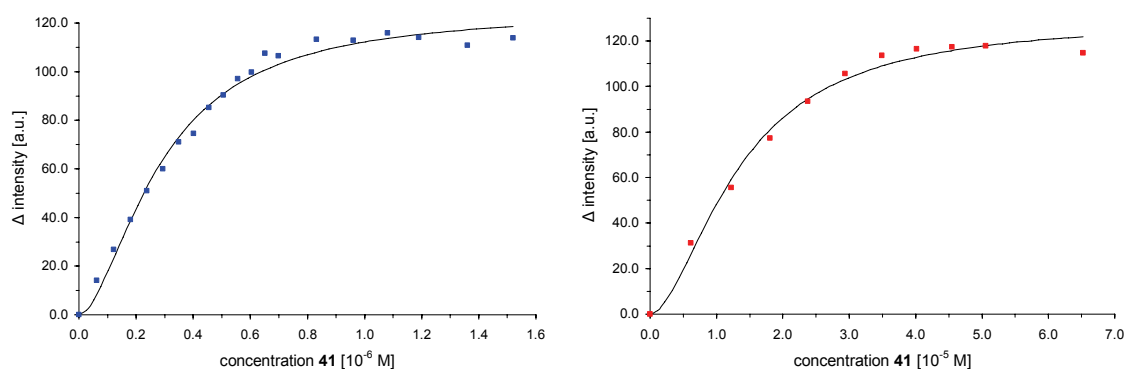

Figure 39: Emission titrations of receptor **41** against peptides **P7** (left) and **P8** (right).

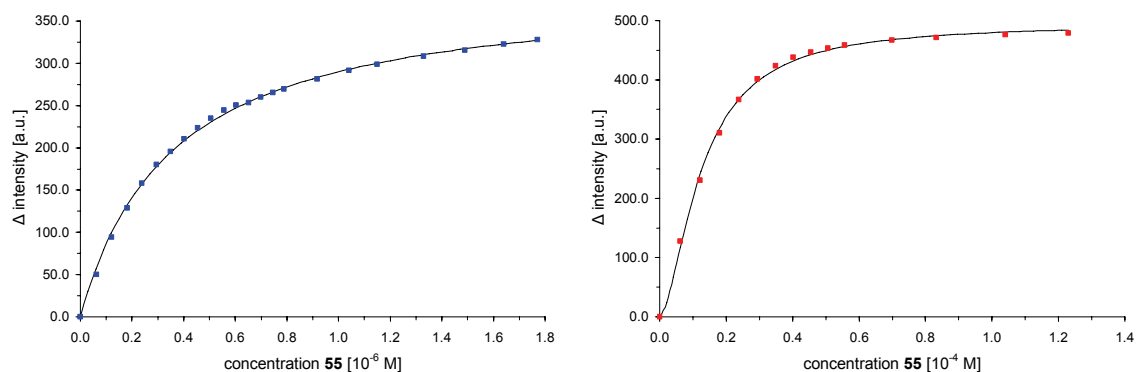

Figure 40: Emission titrations of receptor **55** against peptides **P7** (left) and **P8** (right).

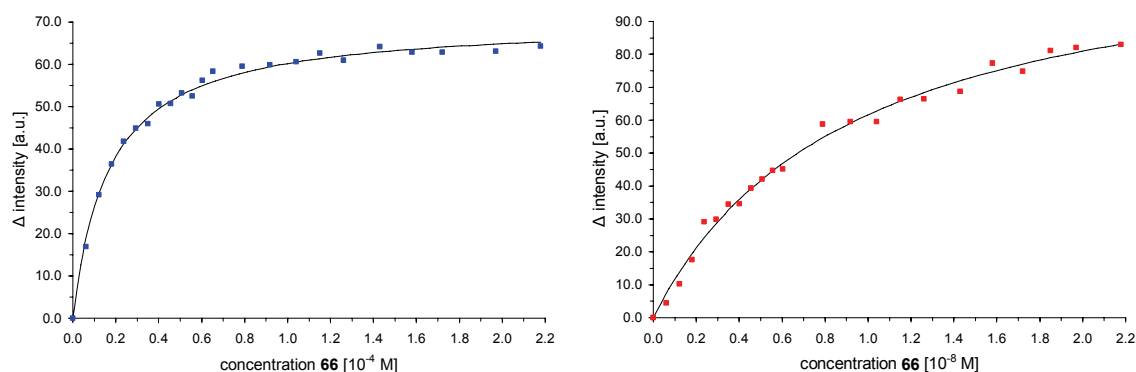

Figure 41: Emission titrations of receptor **66** against peptides **P7** (left) and **P8** (right).

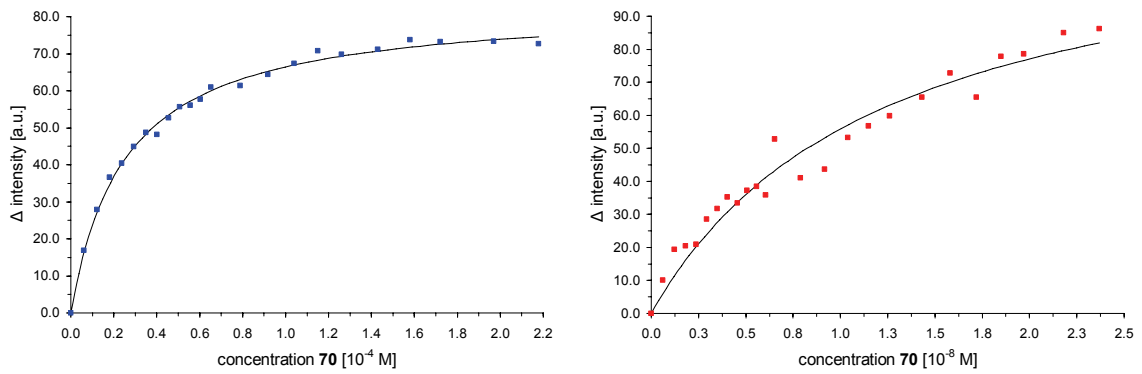

Figure 42: Emission titrations of receptor 70 against peptides P7 (left) and P8 (right).

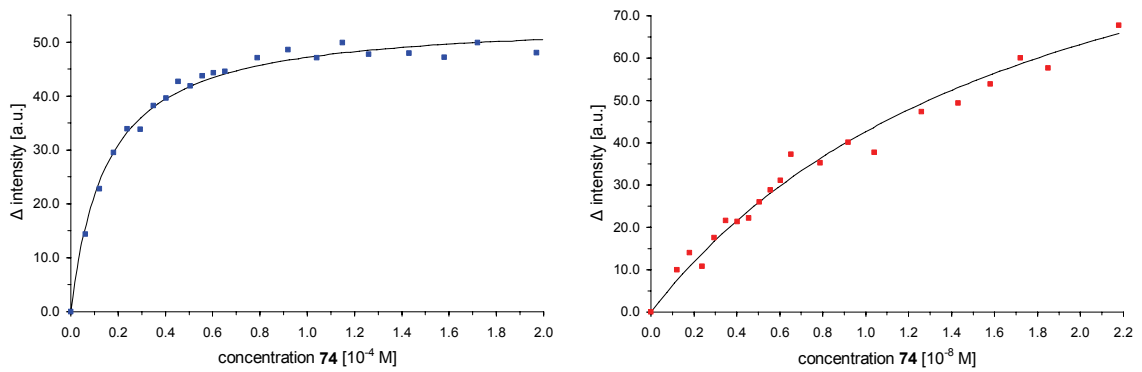

Figure 43: Emission titrations of receptor 74 against peptides P7 (left) and P8 (right).

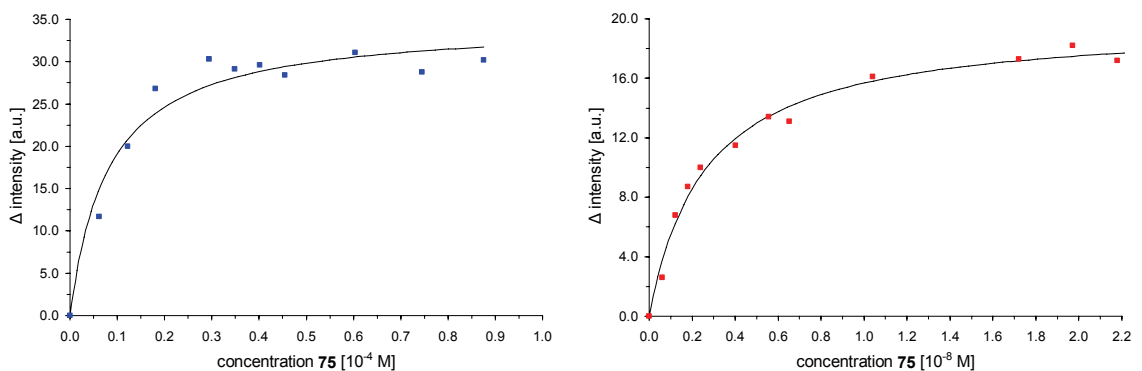

Figure 44: Emission titrations of receptor 75 against peptides P7 (left) and P8 (right).

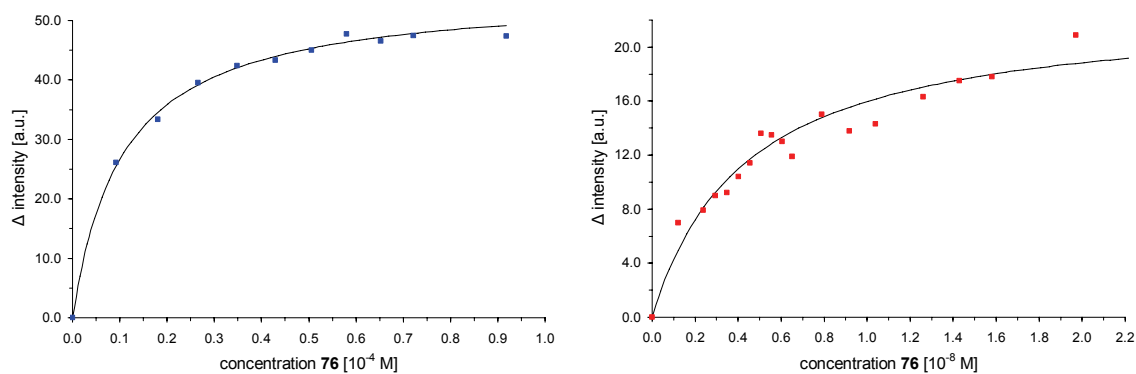

Figure 45: Emission titrations of receptor **76** against peptides **P7** (left) and **P8** (right).

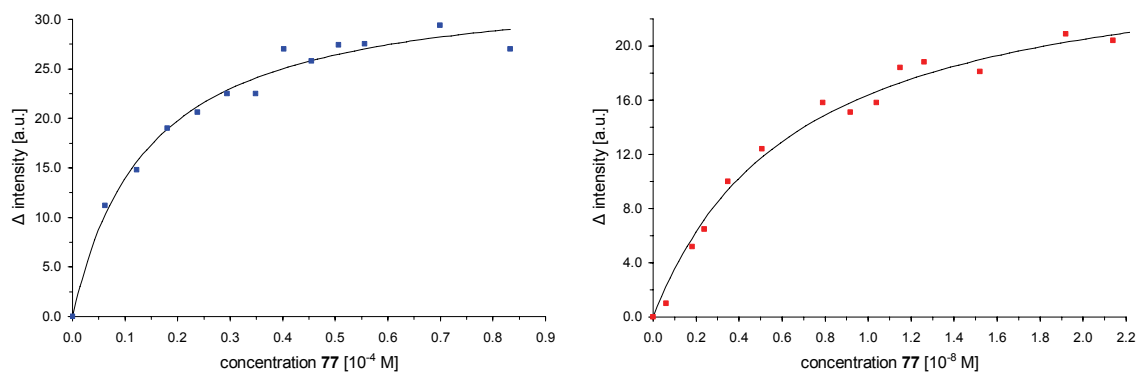

Figure 46: Emission titrations of receptor **77** against peptides **P7** (left) and **P8** (right).

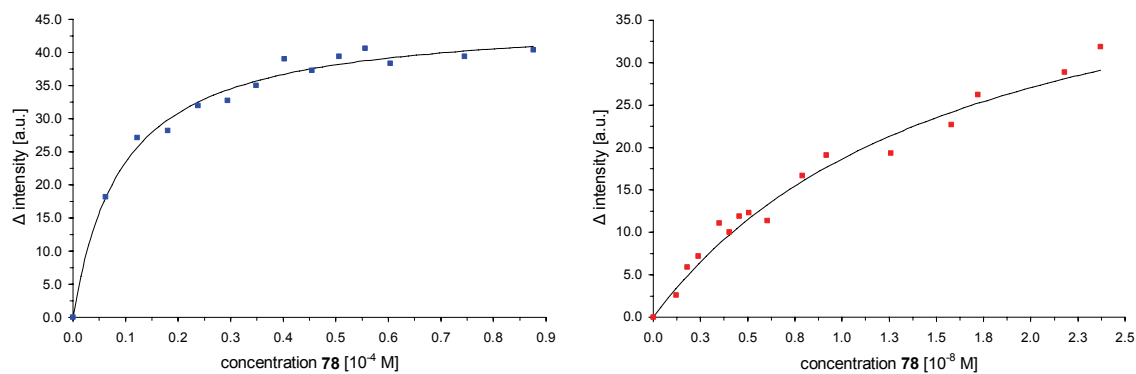

Figure 47: Emission titrations of receptor **78** against peptides **P7** (left) and **P8** (right).

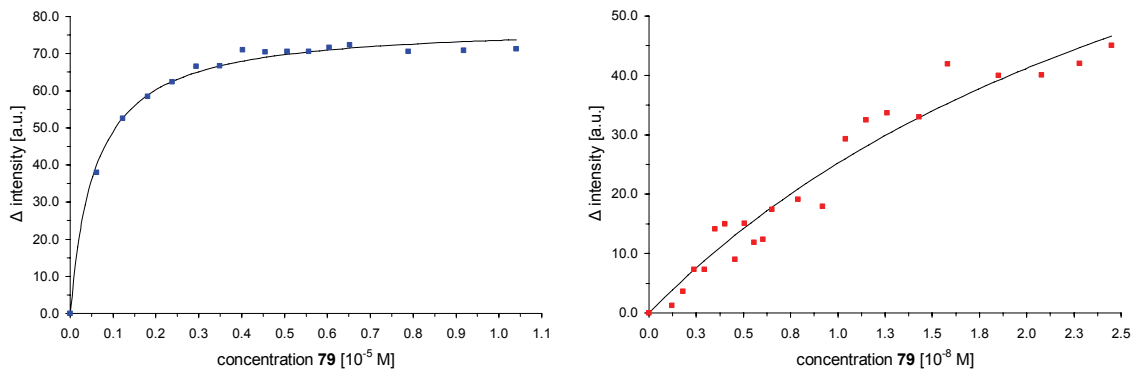

Figure 48: Emission titrations of receptor **79** against peptides **P7** (left) and **P8** (right).

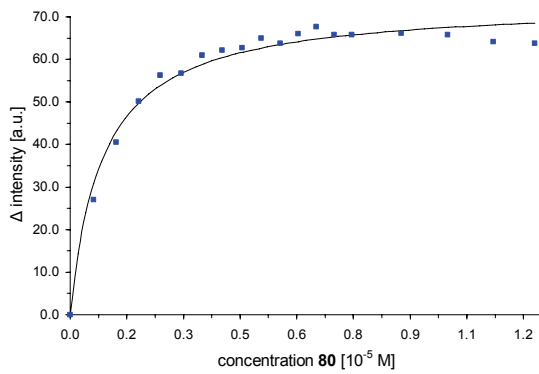

Figure 49: Emission titration of complex **80** representing a receptor substructure against peptide **P7**.

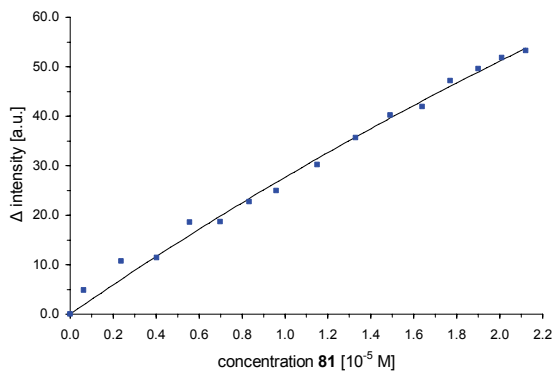

Figure 50: Emission titration of complex **81** representing a receptor substructure against peptide **P7**.

4.2.3. Discussion of the Binding Results

Binding constants of receptors **31**, **36**, **41**, **55**, **66**, **70**, **74** – **79** to peptides **P7** and **P8** were determined by fluorescence emission titrations and non-linear fitting of the data. Job's plots were used to determine the binding stoichiometry, which was found to be 1:1 for all experiments. For comparison, the affinity of complexes **80** and **81**, representing the separate binding sites, to peptides **P7** and **P8** were measured. Table 1 summarizes the results.

Table 1: Binding affinities of complexes **31**, **36**, **41**, **55**, **66**, **70**, **74** and **75** – **81** to peptides **P7** and **P8**.

entry	receptor	binding affinity [logK]	
		peptide P7	peptide P8
1	31	6.5	5.0
2	36	7.5	5.0
3	41	6.5	4.9
4	55	6.5	4.9
5	66	4.8	8.0/8.0 ^a
6	70	4.6	7.9
7	74	4.8	7.8
8	75	5.1	8.3
9	76	4.8	8.2
10	77	5.0	8.4
11	78	5.0	7.8
12	79	5.2	7.5
13	80	4.8	4.8
14	81	< 3	n.d.

^a Reference value from fluorescence polarization titrations.

The tetra(Zn(II)-cyclen) receptors **31**, **36**, **41** and **55** show affinities for the histidine containing peptide 5/6-carboxyfluorescein–Gly–pSer–Ala–Ala–His–Val–NH₂ (**P7**) of $\log K = 6.5 - 7.5$, while the binding to peptide **P8** is one to two orders of magnitude weaker ($\log K = 4.9 - 5.0$). The interaction of the second bis(Zn(II)-cyclen) triazine with the imidazole side chain contributes to the aggregate's stability. Additional entropic stabilization comes from the bivalent structure of **31**, **36**, **41** and **55** with two identical binding sites, in our eyes an example of positive cooperativity in enthalpy.¹¹⁵ The reverse binding selectivity is observed for the receptors **66**, **70** and **74**: The glutamic acid containing peptide **P8** is bound three orders of magnitude stronger ($\log K = 8.0, 7.9$ and 7.8 , respectively) than peptide **P7** ($\log K = 4.8, 4.6$ and 4.8 , respectively). This is in accordance with our expectations, as the interaction of the guanidine binding site with the glutamate carboxylate of peptide **P7** is significantly stronger than with the imidazole side chain of peptide **P8** due to electrostatic attraction. The selectivity of complexes **66**, **70** and **74** is even more pronounced than in the case of the receptors **31**, **36**, **41** and **55** containing two bis(Zn(II)-cyclen) triazine complexes. The bis(Zn(II)-cyclen) triazine Zn(II)-NTA complexes **75 - 79** again show a pronounced selectivity towards peptide **P8** with $\log K = 7.5 - 8.3$. The binding to peptide **P7** is about one thousand fold weaker ($\log K = 4.8 - 5.2$) and we attribute the selectivity to the interaction of the Zn(II)-NTA with the glutamate carboxylate.

Generally, strong cooperativity of binding in the “matched” cases was found, a behavior which has been described before for artificial receptors.¹¹⁶

A comparison of the peptide binding affinities of bis(Zn(II)-cyclen) triazine complex **80** to receptors **31**, **36**, **41**, **55**, **66**, **70**, **74** and **75 - 79** reveals the contribution of the second binding site to the overall affinity. Complex **80** binds to both peptides with identical strength ($\log K = 4.8$), which shows that the interaction of the phosphate ester with the bis(Zn(II)-cyclen) binding site is not affected by the peptide sequence. The binding affinities of receptors **31**, **36**, **41** and **55** to peptide **P8** are similar to this value. This leads to the conclusion that only one bis(Zn(II)-cyclen) complex is involved in the binding of peptide **P8** while both are involved in the binding of peptide **P7**, leading to remarkably higher affinity compared to peptide **P8**. A similar result can be found for the receptors **66**, **70** and **74** which show a similar affinity to **P7** as the receptor substructure **80** does, leading to the conclusion that the interactions of the guanidinium moiety to peptide **P7** are negligible. The same applies to the interaction of receptors **75 - 79** with peptide **P7**: The Zn(II)-NTA – imidazole interaction does not contribute to the receptor affinity as the Zn(II)-NTA – carboxylate binding does. This is confirmed by the binding data of Zn(II)-NTA complex **81** to peptides **P7** and **P8**. A weak, but significant interaction was observed with peptide **P8**, while no interaction was found with peptide **P7**.

The influence of the length and type of the linkers was also analyzed. The smallest and the largest tetra(Zn(II)-cyclen) complexes with a diamine linker **31** and **41** show exactly the same binding affinities to peptide **P7** ($\log K = 6.5$). The naphthalene containing tetra(Zn(II)-cyclen) complex **55** also has the same binding affinity of $\log K = 6.5$ towards **P7**. Only the medium sized complex **41** has a 10-fold higher affinity with $\log K = 7.5$. Reason for this could be that the recognition moieties of receptor **41** have the right distance to match the pSer and the *i*+3 glutamic acid side chains of peptide **P7**. Although the receptors **66**, **70** and **74** have different lengths, the spacer of **66** contains one glycine while **70** has two and **74** three glycines in the linker, this has nearly no influence on the binding constants ($\log K = 8.0, 7.9$ and 7.8 , respectively). Similarly, for the Zn(II)-NTA containing receptors **75** - **79** only a very slight difference of the binding constants towards peptide **P8** was observed. The three receptors **75** – **77** which have nearly the same length have also nearly the same binding affinities ($\log K = 8.3, 8.2$ and 8.4 , respectively). For the longer receptor **78** the affinity decreases to $\log K = 7.8$, again it seems that the receptor becomes too large for an optimal fit to the peptide binding sites. The affinity of receptor **79** is even more reduced because this receptor is even larger than complex **78** and in addition has an aromatic ring in the linker reducing the flexibility of the spacer and with that the affinity towards peptide **P8**. In summary, it was found that the length or type of the linkers connecting the two receptor binding sites has little or no influence on the binding affinity. This is not surprising as the short peptides display no stable secondary structure in solution and the receptors' linkers are highly flexible. This means the binding selectivity and affinity of the receptor molecules rely on the presence of complementary functional groups for non-covalent interaction in reach and not on their exact spatial position.

To verify the results from the emission titrations by an independent method, fluorescence polarization titrations were conducted under identical conditions as the emission titrations. The value determined for receptor **66** (see Table 1) is in good agreement with the result from the emission titration. Fluorescent labels may falsify binding results by contributing to the peptide affinity. To exclude interactions of the label with the receptors, fluorescein sodium was titrated with a receptor of each binding motif showing no emission changes even at large receptor excess.

5. Conclusion

The combination of bis(Zn(II)-cyclen) triazine metal complex binding sites with guanidinium moieties or Zn(II)-NTA complexes leads to artificial receptors for the differentiation of phosphorylated peptides which contain either a histidine side chain or a glutamic acid side chain as a second binding site.

General methods for the synthesis of such bidentate receptors consisting either of two bis(Zn(II)-cyclen) triazine complexes (**31**, **36**, **41**, **55**) or of one bis(Zn(II)-cyclen) triazine complex and a guanidinium moiety (**66**, **70**, **74**) were developed and several receptors varying in length were synthesized.

These complexes in combination with previously prepared complexes consisting of a bis(Zn(II)-cyclen) triazine complex in combination with a Zn(II)-NTA complex (**75** – **79**) were tested in a fluorescence polarization assay against the peptide-protein interaction of different peptides **P1** – **P3** and their corresponding proteins STAT1, STAT3 and GST-Lck. All receptors were found to be active showing an influence on the peptide-protein binding at receptor concentrations of 200 – 600 μM . Unfortunately, it was also found that the incorporation of a second binding site into the receptors did not alter the activity of the compounds significantly.

In addition, the synthesized complexes were used to determine their binding affinities towards the fluorescently labeled peptides 5/6-Carboxyfluorescein–Gly–pSer–Ala–Ala–His–Val–NH₂ (**P7**) and 5/6-Carboxyfluorescein–Gly–pSer–Ala–Ala–Glu–Val–NH₂ (**P8**).

The right combination of binding moieties leads to nanomolar peptide binding affinities in aqueous media at physiological pH. To the best of our knowledge these are the highest affinities of phosphopeptide binding by artificial receptors reported so far. Depending on the second functional group (His or Glu/Asp) beside the phosphate ester, selectivities of up to three orders of magnitude of the binding constant are observed.

Although the bidentate receptors did not show the supposed increased activity in the STAT assay, their remarkably high binding affinities and also selectivities to certain peptide sequences could make them a versatile tool for the inhibition of peptide-protein interactions. Therefore further effort should be undertaken to test the receptors in other biologically relevant systems.

6. Experimental Part

General

All reactions were performed under an inert atmosphere of N₂ using standard Schlenk techniques if not otherwise stated. A Varian Cary BIO 50 UV/VIS/NIR Spectrometer was used. A 1 cm quartz cell was purchased from Hellma and Uvasol solvents from Merck or Baker. IR spectra were recorded on a Bio-Rad FT-IR FTS 155 and a Bio-Rad FTS 2000 MX FT-IR using a Specac Golden Gate Mk II ATR accessory where stated. NMR spectrometers used were: Bruker Avance 600 (¹H: 600.1 MHz, ¹³C: 150.1 MHz, T = 300 K), Bruker Avance 400 (¹H: 400.1 MHz, ¹³C: 100.6 MHz, T = 300 K) and Bruker Avance 300 (¹H: 300.1 MHz, ¹³C: 75.5 MHz, T = 300 K). The chemical shifts are reported in δ [ppm] relative to external standards (solvent residual peak). The spectra were analyzed by first order, the coupling constants are given in Hertz [Hz]. Characterization of the signals: s = singlet, d = doublet, t = triplet, q = quartet, m = multiplet, bs = broad singlet, psq = pseudo quintet, dd = double doublet, dt = double triplet, ddd = double double doublet. Integration is determined as the relative number of atoms. Assignment of signals in ¹³C-spectra was determined with DEPT-technique (pulse angle: 135°) and given as (+) for CH₃ or CH, (-) for CH₂ and (C_{quat}) for quaternary C. Error of reported values: chemical shift: 0.01 ppm for ¹H-NMR, 0.1 ppm for ¹³C-NMR and 0.1 Hz for coupling constants. The solvent used is reported for each spectrum. Mass spectra were recorded on Varian CH-5 (EI), Finnigan MAT 95 (CI; FAB and FD) and Finnigan MAT TSQ 7000 (ESI). Xenon served as the ionization gas for FAB. Melting Points were determined on a Büchi SMP-20 melting point apparatus and are uncorrected. TLC analyses were performed on silica gel 60 F-254 with a 0.2 mm layer thickness. Detection was via UV light at 254 nm / 366 nm or by staining with ninhydrin in EtOH. For preparative column-chromatography, Merck Geduran SI 60 silica gel was used. Commercially available solvents of standard quality were used. If otherwise stated, purification and drying was done according to accepted general procedures.¹¹⁷

The following compounds were synthesized according to literature known procedures: complex **10**,¹¹⁸ bis-cyclen triazine **14**,¹⁰⁵ benzyl 2-aminoethylcarbamate **35**,¹¹⁹ *tert*-butyl 2-aminoethylcarbamate **45**,¹²⁰ complexes **74** – **78**,¹⁰⁴ bis(Zn(II)-cyclen) triazine complex **79**¹¹⁸ and Zn(II)-NTA **80**.⁷⁴

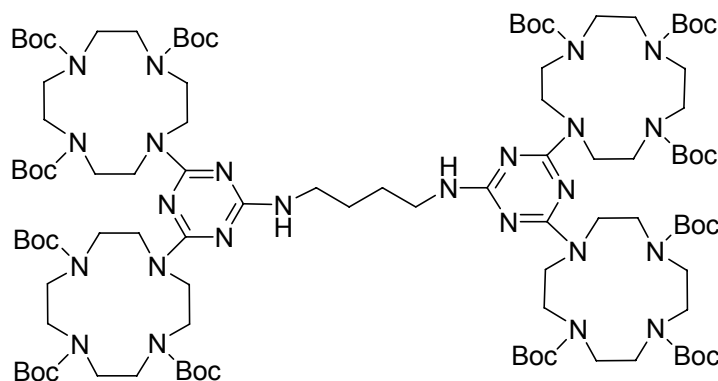

*N*¹,*N*²-Bis(4,6-bis-(tri-Boc-cyc)-1,3,5-triazin-2-yl)butane-1,2-diamine (**30**):

1,4-Diaminobutane **23** (125 mg, 1.42 mmol) was suspended in dioxane and potassium carbonate (785 mg, 5.68 mmol) was added. To the mixture compound **15** (3.00 g, 2.84 mmol) was added and the solution was refluxed for three days under vigorous stirring. The potassium carbonate was filtered off and the solution was evaporated to dryness. The crude product was purified by chromatography on silica gel with EtOAc ($R_f = 0.76$) as eluent to give the product as colorless solid (2.01 g, 0.95 mmol, 67 %).

MP 139-141 °C. – **¹H-NMR** (300 MHz, CDCl₃): $\delta = 1.43$ (s, 108 H, Boc-CH₃), 1.56 (s, 4 H, NH-CH₂-CH₂), 2.93-3.92 (m, 68 H, Cyclen-CH₂ + NH-CH₂), 4.73 (bs, 2 H, NH). – **¹³C-NMR** (75 MHz, CDCl₃): $\delta = 27.5$ (-, 2 C, NH-CH₂-CH₂), 28.5 (+, 36 C, Boc-CH₃), 40.4 (-, 2 C, NH-CH₂), 50.3 (-, 32 C, Cyclen-CH₂), 79.7 (C_{quat}, 12 C, OC(CH₃)₃), 156.4 (C_{quat}, 12 C, Boc-CO), 165.8 (C_{quat}, 6 C, Ar-C). – **MS** (ES, DCM/MeOH + 10 mmol/l NH₄OAc): m/z (%) = 1065.0 (100) [M + 2 H⁺], 2129.1 (9) [MH⁺]. – **Elemental analysis** calcd. (%) for C₁₀₂H₁₈₂N₂₄O₂₄ (2128.68) + H₂O: C 57.07, H 8.64, N 15.66; found: C 57.04, H 8.76, N 15.44. – **IR** (neat) [cm⁻¹]: $\tilde{\nu} = 2980, 2932, 2909, 2863, 1689, 1538, 1466, 1408, 1364, 1245, 1157, 1103, 970, 775$. – **MF** C₁₀₂H₁₈₂N₂₄O₂₄. – **MW** 2128.68.

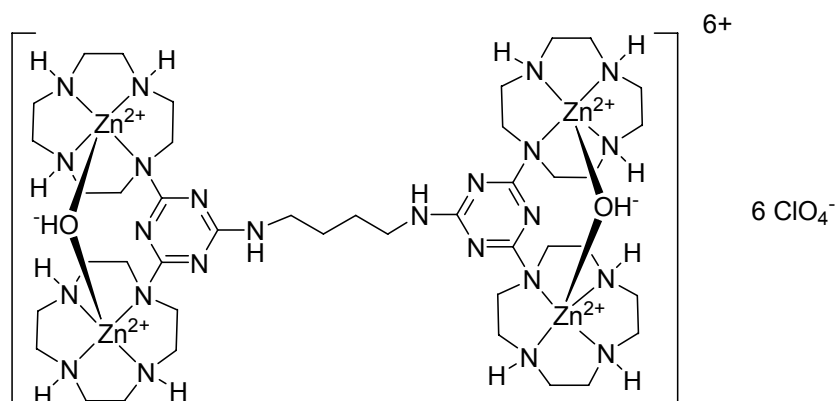
**Complex 31:**

Compound **30** (1.80 mg, 0.85 mmol) was dissolved in methanol and cooled to 0 °C in an ice bath. To the solution HCl saturated diethyl ether (0.7 ml/mmol Boc-group) was added. The mixture was allowed to warm to room temperature and was stirred over night. The solvent was evaporated and the crude product was dissolved in water and purified over an ion exchanger column using a strongly basic ion exchanger to give a colorless solid after freeze drying. Two solutions, one containing the obtained colorless solid from the column in water and a second containing $\text{Zn}(\text{ClO}_4)_2 \cdot 6 \text{H}_2\text{O}$ (655 mg, 1.76 mmol) in absolute ethanol were prepared. These two solutions were simultaneously added to 80 °C hot water. The resulting mixture was stirred at 90 °C over night. The solution was freeze dried and the product was recrystallized from a water methanol mixture to give the complex **31** as colorless solid in 17% yield. (250 mg, 0.14 mmol)

MP > 250 °C. – **MS** (ES, DCM/MeOH + 10 mmol/l NH_4OAc) ($\text{K}^{8+} = \text{C}_{42}\text{H}_{88}\text{N}_{24}\text{Zn}_4$) : m/z (%) = 257.7 (72) [$\text{K}^{8+} + 3 \text{Cl}^-$], 282.7 (62) [$\text{K}^{8+} + \text{Cl}^- + 2 \text{ClO}_4^-$], 446.1 (100) [$\text{K}^{8+} + 2 \text{OH}^- + 2 \text{Cl}^- + \text{CH}_3\text{COO}^-$], 477.4 (81) [$\text{K}^{8+} + 2 \text{OH}^- + \text{CH}_3\text{COO}^- + \text{ClO}_4^-$], 1393.9 (2) [$\text{K}^{8+} + 2 \text{OH}^- + 3 \text{OH}^- + \text{Cl}^- + \text{ClO}_4^-$]. – **IR** (neat) [cm^{-1}]: $\tilde{\nu} = 3277, 2943, 2843, 2366, 2335, 1550, 1420, 1343, 1066, 1055, 962, 809, 621$. – **MF** [$\text{C}_{42}\text{H}_{86}\text{N}_{24}\text{Zn}_4$] $^{8+}(\text{ClO}_4)_6(\text{OH}^-)_2$. – **MW** 1819.54.

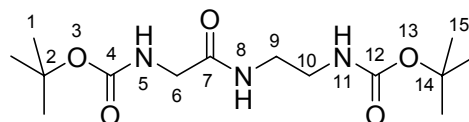

2-(Boc-amino)-N-(2-(Boc-amino)ethyl)acetamide (**82**):

Boc-Gly-OH (**32**) (1.0 g, 5.7 mmol), HOBt (0.85 g, 6.3 mmol) and DIPEA (1.9 ml, 11 mmol) were dissolved in DCM (15 ml). To the solution tert-butyl 2-aminoethylcarbamate (**33**) (1.1 g, 6.9 mmol) was added and the mixture was cooled to 0 °C in an ice bath. Then EDC (1.1 ml, 6.3 mmol) was added. The reaction was monitored by TLC (EtOAc). After 24 h the solution was added to water and extracted with DCM. The combined organic layers were washed twice with an aqueous citric acid solution (10 %) and twice with brine, the solution was dried over MgSO₄ and concentrated under reduced pressure. The crude product was purified by column chromatography on silica gel (EtOAc, R_f = 0.28) to give the product as a colorless solid (1.0 g, 3.3 mmol, 57 %).

MP 110-111 °C. – **¹H-NMR** (300 MHz, CDCl₃): δ = 1.44 (s, 18 H, 1 + 15), 3.24 (s, 2 H, 10), 3.32-3.41 (m, 2 H, 9), 3.78 (s, 2 H, 6), 5.15 (s, 1 H, 11), 5.34 (s, 1 H, 5), 6.91 (s, 1 H, 8). – **¹³C-NMR** (75 MHz, CDCl₃): δ = 28.3 (+, 3 C, 1/15), 28.4 (+, 3 C, 1/15), 40.4 (-, 2 C, 9 + 10), 44.3 (-, 1 C, 6), 79.7 (C_{quat}, 1 C, 2/14), 80.3 (C_{quat}, 1 C, 2/14), 156.1 (C_{quat}, 1 C, 4/12), 156.7 (C_{quat}, 1 C, 4/12), 170.3 (C_{quat}, 1 C, 7). – **MS** (ES, DCM/MeOH + 10 mmol/l NH₄OAc): *m/z* (%) = 318.1 (100) [MH⁺], 635.5 (16) [2 M + H⁺]. – **IR** (neat) [cm⁻¹]: $\tilde{\nu}$ = 3334, 2980, 2936, 2360, 1685, 1650, 1521, 1365, 1281, 1244, 1167, 1066, 864. – **MF** C₁₄H₂₇N₃O₅. – **MW** 317.38.

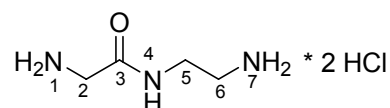

2-Amino-N-(2-aminoethyl)acetamide·2 HCl (**34**):

Compound **82** (1.0 g, 3.2 mmol) was dissolved in methanol and cooled to 0 °C in an ice bath. To this mixture 10 ml of HCl saturated diethyl ether were added. The mixture was allowed to warm to room temperature and stirred over night. The reaction progress was monitored by ¹H-NMR. The mixture was concentrated under reduced pressure and dried at high vacuum to obtain the product as a colorless solid in quantitative yield (0.60 g, 3.2 mmol).

MP > 180 °C. – **¹H-NMR** (300 MHz, D₂O): δ = 3.10 (t, ³J_{H,H} = 5.9, 2 H, 6), 3.51 (t, ³J_{H,H} = 6.0, 2 H, 5), 3.78 (s, 2 H, 2). – **¹³C-NMR** (75 MHz, D₂O): δ = 36.9 (-, 1 C, CH₂), 39.1 (-, 1 C, CH₂), 40.6 (-, 1 C, CH₂), 168.1 (C_{quat}, 1 C, CO). – **MS** (CI, NH₃): *m/z* (%) = 118.1 (100)

[MH⁺]. – IR (neat) [cm⁻¹]: $\tilde{\nu}$ = 3166, 2913, 2757, 2360, 2061, 1673, 1567, 1494, 1391, 1274, 1176, 1070, 901, 757. – MF C₄H₁₁N₃O x 2 HCl. – MW 254.07.

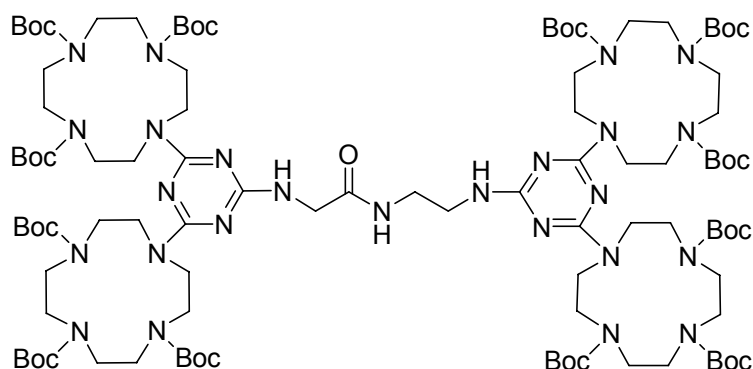

Hexa-tert-butyl 10,10'-(6-(2-(2-(4,6-bis(4,7,10-tris(tert-butoxycarbonyl)-1,4,7,10-tetraaza-cyclodo-decan-1-yl)-1,3,5-triazin-2-ylamino)acetamido)ethylamino)-1,3,5-triazine-2,4-diyl) bis(1,4,7,10-tetraazacyclododecane-1,4,7-tricarboxylate) (35):

Compound **34** (0.20 g, 1.1 mmol) was suspended in dioxane and potassium carbonate (5.8 g, 42 mmol) was added. The mixture was stirred for 30 min then compound **15** (2.2 g, 2.1 mmol) was added and the solution was refluxed for three days under vigorous stirring. The potassium carbonate was filtered off, the solution was evaporated to dryness and the crude product was purified by chromatography on silica gel with EtOAc (R_f = 0.76) as eluent to give the product **35** as colorless solid (1.5 g, 0.71 mmol, 68 %).

MP 179-180 °C. – **¹H-NMR** (300 MHz, CDCl₃): δ = 1.43 (s, 108 H, Boc-CH₃), 2.85-3.93 (m, 70 H, Cyclen-CH₂ + NH-CH₂), 5.27 (bs, 2 H, NH), 7.34 (s, 1 H, NH). – **¹³C-NMR** (75 MHz, CDCl₃): δ = 28.5 (+, 36 C, Boc-CH₃), 40.6 (-, 1 C, NH-CH₂), 42.3 (-, 1 C, NH-CH₂-CH₂), 46.4 (-, 1 C, CH₂-CO), 50.3 (-, 32 C, Cyclen-CH₂), 79.9 (C_{quat}, 12 C, OC(CH₃)₃), 156.3 (C_{quat}, 12 C, Boc-CO), 165.8 (C_{quat}, 6 C, Ar-C), 169.5 (C_{quat}, 1 C, CH₂-CO). – **MS** (ES, DCM/MeOH + 10 mmol/l NH₄OAc): m/z (%) = 1079.5 (100) [M + 2 H⁺], 2158.2 (13) [MH⁺]. – IR (neat) [cm⁻¹]: $\tilde{\nu}$ = 2974, 2932, 2359, 1686, 1539, 1466, 1408, 1364, 1246, 1158, 1105, 971, 776. – MF C₁₀₂H₁₈₁N₂₅O₂₅. – MW 2157.68.

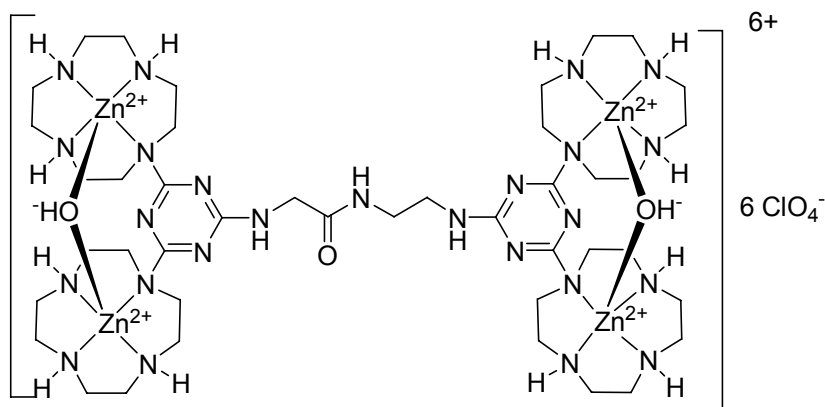

Complex **36**:

Compound **35** (0.94 g, 0.44 mmol) was dissolved in methanol and cooled to 0 °C in an ice bath. To the solution HCl saturated diethyl ether (0.7 ml/mmol Boc-group) was added. The mixture was allowed to warm to room temperature, stirred over night, the solvent was evaporated, the crude product was dissolved in water and purified over an ion exchanger column using a strongly basic ion exchanger to give the product as a colorless solid after lyophilization. Two solutions were prepared: one containing the obtained colorless solid from the column in water and a second containing $\text{Zn}(\text{ClO}_4)_2 \cdot 6 \text{H}_2\text{O}$ (0.66 g, 1.8 mmol) in absolute ethanol. The two solutions were simultaneously added to hot water (80 °C). The resulting mixture was stirred at 90 °C over night. The solution was lyophilized and the product was recrystallized from a water/methanol mixture to give the complex **36** as colorless solid in 84% yield. (0.69 g, 0.37 mmol)

MP > 250 °C. – **MS** (ES, $\text{H}_2\text{O}/\text{MeOH} + 10 \text{ mmol/l NH}_4\text{OAc}$) ($\text{K}^{6+} = \text{C}_{48}\text{H}_{93}\text{N}_{19}\text{O}_3\text{ClZn}_4$) : m/z (%) = 252.0 (50) [$\text{K}^{6+} + \text{OH}^-$], 368.9 (41) [$\text{K}^{6+} + \text{Cl}^- + \text{ClO}_4^- + \text{HClO}_4$], 484.1 (93) [$\text{K}^{6+} + \text{OH}^- + 2 \text{ClO}_4^-$], 517.7 (100) [$\text{K}^{6+} + \text{OH}^- + 2 \text{ClO}_4^- + \text{HClO}_4$], 826.0 (29) [$\text{K}^{6+} + \text{OH}^- + 3 \text{ClO}_4^- + \text{HClO}_4$]. – **IR** (neat) [cm^{-1}]: $\tilde{\nu} = 3567, 3527, 3284, 2942, 2890, 2357, 1549, 1480, 1423, 1343, 1067, 812$. – **MF** [$\text{C}_{42}\text{H}_{85}\text{N}_{25}\text{OZn}_4$] $^{8+}(\text{ClO}_4)_6(\text{OH}^-)_2$. – **MW** 1848.54.

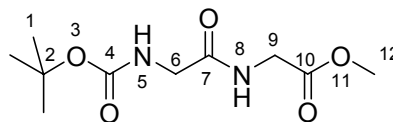

Methyl 2-(2-(tert-butoxycarbonylamino)acetamido)acetate (83):

Boc-Gly-OH (**32**) (1.2 g, 6.7 mmol), HOBt (1.1 g, 8.0 mmol) and DIPEA (1.9 ml, 11 mmol) were dissolved in DCM (20 ml). The solution was cooled to 0 °C in an ice bath and then EDC (1.4 ml, 8.0 mmol) was added. After several minutes H-Gly-OMe·HCl (**37**) was added in portions. The solution was allowed to warm to room temperature and was stirred over night. The reaction was monitored by TLC (EtOAc). After 24 h the solution was added to water, extracted with DCM, the combined organic layers were washed twice with an aqueous citric acid solution (10 %) and twice with brine. The organic layer was dried over MgSO₄, concentrated at reduced pressure and the crude product was purified by column chromatography on silica gel (EtOAc, R_f = 0.34) to give the product as a colorless oil (0.93 g, 3.8 mmol, 57 %).

¹H-NMR (300 MHz, CDCl₃): δ = 1.45 (s, 9 H, 1), 3.75 (s, 3 H, 12), 3.85 (s, 2 H, 6), 4.06 (d, ³J_{H,H} = 5.5, 2 H, 9), 5.23 (s, 1 H, 5), 6.73 (s, 1 H, 8). – ¹³C-NMR (75 MHz, CDCl₃): δ = 28.3 (+, 3 C, 1), 41.1 (-, 1 C, 9), 44.2 (-, 1 C,), 52.5 (+, 1 C, 12), 80.5 (C_{quat}, 1 C, 2), 156.1 (C_{quat}, 1 C, 4), 169.8 (C_{quat}, 1 C, 4/7), 171.8 (C_{quat}, 1 C, 4/7). – MS (CI, NH₃): m/z (%) = 147.1 (49) [MH⁺ - Boc], 164.1 (51) [MNH₄⁺ - Boc], 191.1 (16) [MH⁺ - C₄H₈], 208.1 (63) [MNH₄⁺ - C₄H₈], 247.1 (58) [MH⁺], 264.1 (100) [MNH₄⁺]. – IR (neat) [cm⁻¹]: ν̃ = 3281, 2979, 2359, 2338, 1660, 1525, 1366, 1250, 1161, 1030, 953. – MF C₁₀H₁₈N₂O₅. – MW 246.26.

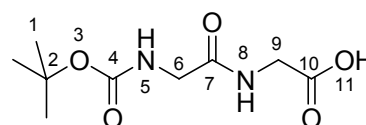

2-(2-(tert-butoxycarbonylamino)acetamido)acetic acid (38):

Boc-Gly-Gly-OMe (**83**) (0.50 g, 2.0 mmol) was dissolved in 10 ml of methanol and 4 ml of an 1 M aqueous sodium hydroxide solution was added. The solution was stirred over night and the methanol was evaporated under reduced pressure. The residue was acidified with aqueous KHSO₄ solution (5 %), the mixture was extracted three times with EtOAc, the combined organic layers were dried over MgSO₄ and concentrated under reduced pressure to give the product as a colorless solid. (0.42 g, 1.8 mmol, 88 %).

MP 115-116 °C. – ¹H-NMR (300 MHz, CDCl₃): δ = 1.28 (s, 9 H, 1), 3.63 (s, 2 H, 6), 3.81 (s, 2 H, 9). – ¹³C-NMR (75 MHz, CDCl₃): δ = 23.5 (+, 3 C, 1), 40.7 (+, 1 C, 6/9), 43.4 (+, 1 C, 6/9), 80.1 (C_{quat}, 1 C, 2), 156.5 (C_{quat}, 1 C, 4), 170.7 (C_{quat}, 1 C, 7/10), 171.4 (C_{quat}, 1 C,

7/10). – **MS** (Cl, NH₃): *m/z* (%) = 231.0 (100) [M - H⁺], 267.0 (20) [MCl], 462.8 (22) [2 M - H⁺]. – **IR** (neat) [cm⁻¹]: $\tilde{\nu}$ = 3357, 2986, 2933, 2359, 1735, 1686, 1620, 1523, 1439, 1221, 1156, 1056, 946, 857. – **MF** C₉H₁₆N₂O₅. – **MW** 232.23.

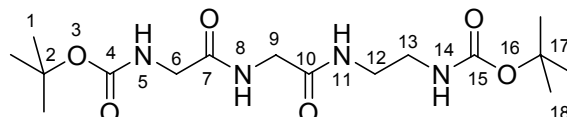

tert-Butyl 2-(2-(2-(Boc-amino)acetamido)acetamido)ethylcarbamate (**84**):

Boc-Gly-Gly-OH (**38**) (1.2 g, 5.2 mmol), HOBT (0.91 g, 6.7 mmol) and DIPEA (2.7 ml, 15 mmol) were dissolved in DCM (15 ml). To the solution tert-butyl 2-aminoethylcarbamate (**33**) (1.2 g, 7.8 mmol) was added and the mixture was cooled to 0 °C in an ice bath. Then EDC (1.1 ml, 6.7 mmol) was added and the reaction was monitored by TLC (EtOAc). After 24 h the solution was added to water and extracted with DCM. The combined organic layers were washed twice with an aqueous citric acid solution (10 %), twice with brine, the organic layer was dried over MgSO₄ and concentrated under reduced pressure. The crude product was purified by column chromatography on silica gel (EtOAc:EtOH 80:20, R_f = 0.09) to give the product as a colorless oil (0.81 g, 2.2 mmol, 42 %).

MP 116-117 °C. – **¹H-NMR** (300 MHz, CDCl₃): δ = 1.43 (s, 9 H, 1/18), 1.45 (s, 9 H, 1/18), 3.19-3.30 (s, 2 H, 13), 3.32-3.43 (m, 2 H, 12), 3.85 (s, 2 H, 6), 3.97 (d, ³J_{H,H} = 5.5, 2 H, 9), 5.31 (bs, 1 H, 14), 5.56 (bs, 1 H, 5), 7.19 (bs, 2 H, 8 + 11). – **¹³C-NMR** (75 MHz, CDCl₃): δ = 28.3 (+, 3 C, 1/18), 28.4 (+, 3 C, 1/18), 40.4 (-, 2 C, 9 + 10), 42.9 (-, 1 C, 9), 44.4 (-, 1 C, 6), 79.8 (C_{quat}, 1 C, 2/117), 80.5 (C_{quat}, 1 C, 2/17), 156.4 (C_{quat}, 1 C, 4/15), 156.8 (C_{quat}, 1 C, 4/15), 169.4 (C_{quat}, 1 C, 10), 170.4 (C_{quat}, 1 C, 7). – **MS** (ES, DCM/MeOH + 10 mmol/l NH₄OAc): *m/z* (%) = 319.1 (36) [MH⁺ - C₄H₈], 375.2 (100) [MH⁺], 392.2 (32) [MNH₄⁺]. – **IR** (neat) [cm⁻¹]: $\tilde{\nu}$ = 3280, 3184, 2983, 2360, 1677, 1660, 1569, 1464, 1262, 1178, 1108, 954, 878. – **MF** C₁₆H₃₀N₄O₆. – **MW** 374.43.

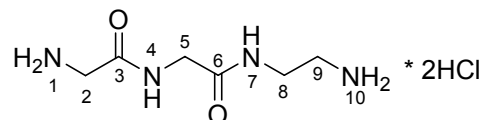

2-Amino-N-(2-(2-aminoethylamino)-2-oxoethyl)acetamide · 2 HCl (39):

Compound **84** (0.81 g, 2.2 mmol) was dissolved in methanol and cooled to 0 °C in an ice bath. To this mixture 12 ml of HCl saturated diethyl ether were added. The mixture was allowed to warm to room temperature and stirred over night. The reaction progress was monitored by $^1\text{H-NMR}$. The mixture was concentrated under reduced pressure and dried under high vacuum to obtain the product as a colorless solid in 90% yield (0.48 g, 1.9 mmol).

MP > 250 °C. – **$^1\text{H-NMR}$** (300 MHz, D_2O): δ = 3.07 (t, $^3J_{\text{H,H}}$ = 5.8, 2 H, 9), 3.45 (t, $^3J_{\text{H,H}}$ = 5.9, 2 H, 8), 3.82 (s, 2 H, 2), 3.92 (s, 2 H, 5). – **$^{13}\text{C-NMR}$** (75 MHz, D_2O): δ = 36.9 (-, 1 C, 9), 39.2 (-, 1 C, 8), 40.5 (-, 1 C, 2), 42.5 (-, 1 C, 5), 168.0 (C_{quat} , 1 C, CO), 172.2 (C_{quat} , 1 C, CO). – **MS** (Cl, NH_3): m/z (%) = 175.1 (100) [MH^+]. – **IR** (neat) [cm^{-1}]: $\tilde{\nu}$ = 3280, 2990, 2879, 2359, 2016, 1677, 1660, 1570, 1465, 1264, 1178, 1108, 1009, 906, 788. – **MF** $\text{C}_6\text{H}_{14}\text{N}_4\text{O}_2 \times 2 \text{HCl}$. – **MW** 247.12.

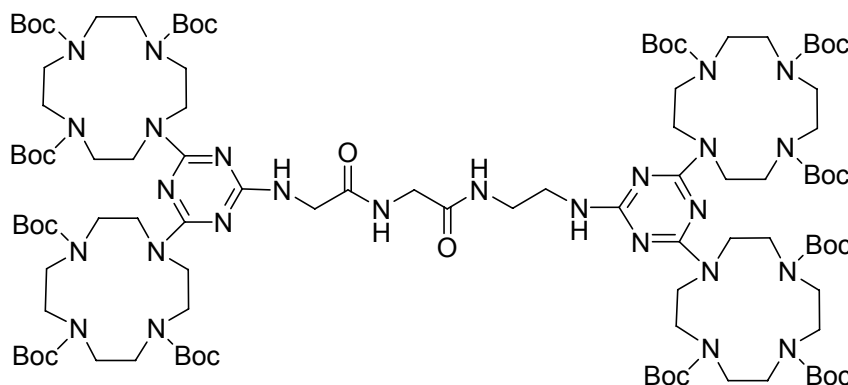

Hexa-tert-butyl 10,10'-(6-(2-(2-(2-(4,6-bis(4,7,10-tris(tert-butoxycarbonyl)-1,4,7,10-tetraazacyclododecan-1-yl)-1,3,5-triazin-2-ylamino)acetamido)acetamido)ethylamino)-1,3,5-triazine-2,4-diyl)bis(1,4,7,10-tetraazacyclododecane-1,4,7-tricarboxylate) (40):

Compound **39** (0.35 g, 1.4 mmol) was suspended in dioxane and potassium carbonate (7.9 g, 57 mmol) was added. The mixture was stirred for 30 min, then compound **15** (3.0 g, 2.8 mmol) was added and the solution was refluxed for three days under vigorous stirring. The potassium carbonate was filtered off. The solution was evaporated to dryness and the crude product was purified by chromatography on silica gel with EtOAc ($R_f = 0.30$) as eluent to give the product **40** as a colorless solid (1.9 g, 0.62 mmol, 44 %).

MP 162-163 °C. – **¹H-NMR** (300 MHz, CDCl_3): $\delta = 1.43$ (s, 108 H, Boc- CH_3), 2.85-4.08 (m, 72 H, Cyclen- CH_2 + NH- CH_2), 5.05 (bs, 2 H, NH). – **¹³C-NMR** (75 MHz, CDCl_3): $\delta = 28.5$ (+, 36 C, Boc- CH_3), 39.9 (-, 1 C, NH- CH_2), 42.8 (-, 1 C, NH- CH_2 - CH_2), 44.8 (-, 1 C, CH_2 -CO), 47.4 (-, 1 C, CH_2 -CO), 50.3 (-, 32 C, Cyclen- CH_2), 79.8 (C_{quat} , 12 C, $\text{OC}(\text{CH}_3)_3$), 156.8 (C_{quat} , 12 C, Boc-CO), 165.8 (C_{quat} , 6 C, Ar-C), 169.5 (C_{quat} , 1 C, CH_2 -CO). – **MS** (ES, DCM/MeOH + 10 mmol/l NH_4OAc): m/z (%) = 1108.5 (100) [$\text{M} + 2 \text{H}^+$], 2115.3 (8) [MH^+]. – **IR** (neat) [cm^{-1}]: $\tilde{\nu} = 2974, 2933, 2360, 2344, 1686, 1539, 1466, 1409, 1364, 1246, 1158, 971, 858$. – **MF** $\text{C}_{102}\text{H}_{184}\text{N}_{26}\text{O}_{26}$. – **MW** 2214.73.

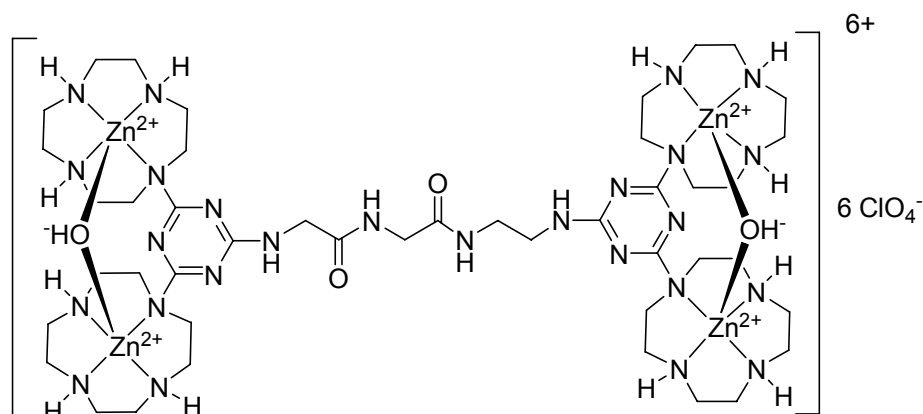
**Complex 41:**

The Boc protected compound **40** (1.4 g, 0.62 mmol) was dissolved in methanol and cooled to 0 °C in an ice bath. To this solution HCl saturated diethyl ether (0.7 ml/mmol Boc-group) was added. The mixture was allowed to warm to room temperature and was stirred over night. The solvent was evaporated, the crude product was dissolved in water and purified over an ion exchanger column using a strongly basic ion exchanger (OH⁻-form, loading 0.9 mmol/ml, 4 eq. per protonated nitrogen) to give a colorless solid after lyophilization. Then two solutions were prepared: one containing the obtained colorless solid from the column in water and a second one containing Zn(ClO₄)₂ · 6 H₂O (0.90 g, 2.4 mmol, 4.4 eq. per deprotected receptor) in absolute ethanol. These two solutions were simultaneously added drop wise to water at 80 °C under vigorous stirring. The resulting mixture was stirred at 90 °C over night, and then lyophilized. The product was recrystallized from a water methanol mixture to give the complex as a colorless solid in 63 % yield. (0.75 g, 0.39 mmol).

MP > 250 °C. – **MS** (ES, H₂O/AcN/MeOH + 10 mmol/l NH₄OAc) (K⁸⁺ = C₄₄H₈₈N₂₆O₂Zn₄) : *m/z* (%) = 377.7 (82) [K⁸⁺ + 4 CH₃COO⁻], 503.4 (52) [K⁸⁺ + OH⁻ + Cl⁻ + 3 CH₃COO⁻], 536.8 (100) [K⁸⁺ + 4 CH₃COO⁻ + ClO₄⁻], 854.5 (15) [K⁸⁺ + OH⁻ + 2 CH₃COO⁻ + 3 ClO₄⁻], 875.4 (14) [K⁸⁺ + OH⁻ + CH₃COO⁻ + 4 ClO₄⁻], 896.0 (16) [K⁸⁺ + OH⁻ + 5 ClO₄⁻]. – **IR** (neat) [cm⁻¹]: $\tilde{\nu}$ = 3585, 3387, 3296, 2943, 2894, 2360, 1652, 1548, 1480, 1424, 1343, 1286, 1232, 1067, 962, 808. – **MF** [C₄₄H₉₀N₂₆O₂Zn₄]⁸⁺(ClO₄)₆(OH)₂. – **MW** 1905.59.

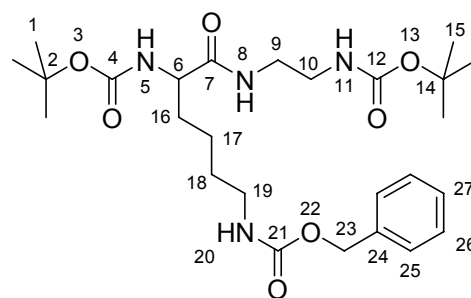

Boc-Lys(Cbz)-ED-Boc (47):

Boc-Lys(Cbz)-OH **42** (2.00 g, 5.26 mmol), HOBt (781 mg, 5.78 mmol) and DIPEA (1.80 ml, 10.5 mmol) were dissolved in DCM (15 ml). To the solution tert-butyl 2-aminoethylcarbamate **33** (1.01 g, 6.31 mmol) was added and the mixture was cooled to 0 °C in an ice bath. Then EDC (1.02 ml, 5.78 mmol) was added. The reaction was monitored by TLC (EtOAc). After 24 hours the solution was uptaken in water and extracted with DCM. The combined organic layers were then washed twice with an aqueous citric acid solution (10 %) and twice with brine. Afterwards the solution was dried over MgSO₄ and concentrated under reduced pressure. The crude product was purified by column chromatography on silica gel (EtOAc, R_f = 0.45) to give the product as colorless solid (2.31 g, 4.42 mmol, 84 %).

MP 101-102 °C. – **¹H-NMR** (300 MHz, CDCl₃): δ = 1.29-91 (m, 24 H, 1 + 15 + 16 + 17 + 18), 3.12-3.29 (m, 4 H, 10 + 19), 3.31-3.42 (m, 2 H, 9), 4.01 (m, 1 H, 6), 4.95-5.18 (m, 4 H, 11 + 20 + 23), 5.26 (s, 1 H, 5), 6.74 (s, 1 H, 8), 7.28-7.40 (m, 5 H, 25 + 26 + 27). – **¹³C-NMR** (75 MHz, CDCl₃): δ = 22.5 (-, 1 C, 17), 28.3 (+, 3 C, 1/15), 28.4 (+, 3 C, 1/15), 29.4 (-, 1 C, 18), 32.0 (-, 1 C, 16), 40.4 (-, 3 C, 9 + 10 + 19), 54.5 (-, 1 C, 6), 66.7 (-, 1 C, 23), 79.7 (C_{quat}, 1 C, 2/14), 80.1 (C_{quat}, 1 C, 2/14), 128.1 (+, 3 C, 25 + 27), 128.5 (+, 2 C, 26), 136.6 (C_{quat}, 1 C, 24), 155.9 (C_{quat}, 1 C, 4/12/22), 156.6 (C_{quat}, 1 C, 4/12/22), 156.7 (C_{quat}, 1 C, 4/12/21), 172.7 (C_{quat}, 1 C, 7). – **MS** (ES, DCM/MeOH + 10 mmol/l NH₄OAc): *m/z* (%) = 423.3 (15) [MH⁺ - Boc], 523.4 (100) [MH⁺]. – **IR** (neat) [cm⁻¹]: $\tilde{\nu}$ = 3336, 2985, 2941, 1683, 1656, 1521, 1367, 1242, 1163, 1055, 981, 694. – **MF** C₂₆H₄₂N₄O₇. – **MW** 522.63.

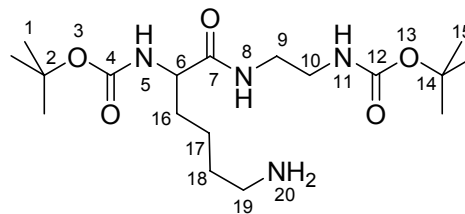
**Boc-Lys-ED-Boc (43):**

Compound **47** (1.00 g, 1.91 mmol) was dissolved in methanol. To this mixture one spatula of Pd on activated charcoal (10 % Pd) was added. The mixture was stirred under 10 bar of H₂ over night. The Pd was filtered off and the mixture was concentrated under reduced pressure and dried under high vacuum to obtain the product as colorless oil in 94 % yield (700 mg, 1.80 mmol). No further purification was necessary.

MP 44-45 °C. – **¹H-NMR** (300 MHz, CDCl₃): δ = 1.35-86 (m, 24 H, 1 + 15 + 16 + 17 + 18), 2.45 (s, 2 H, 20), 2.72 (t, ³J_{H,H} = 6.3, 2 H, 19), 3.15-3.29 (m, 2 H, 10), 3.30-3.41 (m, 2 H, 9), 4.04 (s, 1 H, 6), 5.23 (s, 2 H, 5 + 11), 7.03 (s, 1 H, 8). – **¹³C-NMR** (75 MHz, CDCl₃): δ = 22.6 (-, 1 C, 17), 28.4 (+, 6 C, 1 + 15), 32.2 (-, 1 C, 16/18), 32.4 (-, 1 C, 16/18), 40.2 (-, 2 C, 9 + 10), 41.3 (-, 1 C, 19), 54.5 (+, 1 C, 6), 79.5 (C_{quat}, 1 C, 2/14), 80.0 (C_{quat}, 1 C, 2/14), 155.8 (C_{quat}, 1 C, 4/12), 156.6 (C_{quat}, 1 C, 4/12), 172.7 (C_{quat}, 1 C, 7). – **MS** (ES, DCM/MeOH + 10 mmol/l NH₄OAc): *m/z* (%) = 389.1 (100) [MH⁺], 777.6 (31) [2M + H⁺]. – **IR** (neat) [cm⁻¹]: $\tilde{\nu}$ = 2976, 2931, 2866, 1689, 1658, 1516, 1365, 1247, 1167, 1045, 1015. – **MF** C₁₈H₃₆N₄O₅. – **MW** 388.50.

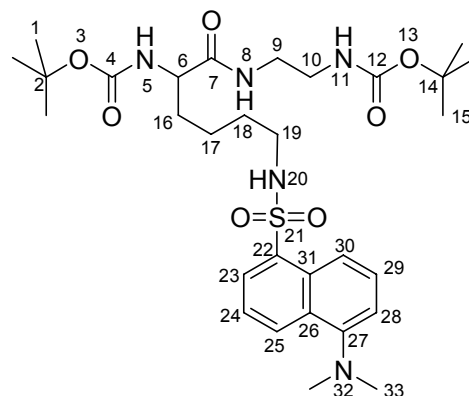

Boc-Lys(Ds)-ED-Boc (85):

Compound **43** (700 mg, 1.80 mmol) was dissolved in 10 ml of DCM and was cooled to 0 °C in an ice bath. To the solution NEt₃ (749 µl, 5.41 mmol) was added drop by drop. Then the dansyl chloride **44** (729 mg, 2.70 mmol) was added in portions. The solution was allowed to warm to room temperature and was stirred over night. The solution was uptaken in water and was extracted with DCM three times. The combined organic layers were washed twice with brine. Afterwards the solution was dried over MgSO₄ and concentrated under reduced pressure. The crude product was purified by column chromatography on silica gel (EtOAc, R_f = 0.51) to give the product as yellow solid (1.04 g, 1.67 mmol, 93 %).

MP 88-89 °C. – **¹H-NMR** (300 MHz, CDCl₃): δ = 1.24-1.78 (m, 24 H, 1 + 15+ 16 + 17 + 18), 2.83-2.95 (m, 8 H, 19 + 33), 3.19-3.41 (m, 4 H, 9 + 10), 4.00 (s, 1 H, 6), 5.16-5.32 (m, 2 H, 5 + 11), 5.46 (s, 1 H, 20), 6.80 (s, 1 H, 8), 7.19 (d, ³J_{H,H} = 7.4, 1 H, H-Ar), 7.48-7.59 (m, 2 H, H-Ar), 8.23 (dd, ³J_{H,H} = 7.4, ³J_{H,H} = 1.1, 1 H, H-Ar), 8.32 (d, ³J_{H,H} = 8.5, 1 H, H-Ar), 8.55 (d, ³J_{H,H} = 8.5, 1 H, H-Ar). – **¹³C-NMR** (75 MHz, CDCl₃): δ = 22.3 (-, 1 C, 17), 28.4 (+, 6 C, 1/15), 29.0 (-, 1 C, 18), 32.0 (-, 1 C, 16), 40.3 (-, 2 C, 9 + 10), 42.8 (-, 1 C, 19), 45.5 (+, 2 C, 33), 54.3 (+, 1 C, 6), 79.6 (C_{quat}, 1 C, 2/14), 80.1 (C_{quat}, 1 C, 2/14), 115.4 (+, 1 C, 28), 123.4 (+, 1 C, 30), 128.3 (+, 1 C, 23), 129.6 (+, 2 C, 24 + 29), 129.6 (C_{quat}, 1 C, 26), 129.7 (C_{quat}, 1 C, 31), 130.2 (+, 1 C, 25), 134.9 (C_{quat}, 1 C, 22), 155.8 (C_{quat}, 1 C, 4/12), 155.9 (C_{quat}, 1 C, 27), 156.7 (C_{quat}, 1 C, 4/12), 172.6 (C_{quat}, 1 C, 7). – **MS** (ES, DCM/MeOH + 10 mmol/l NH₄OAc): *m/z* (%) = 566.3 (34) [MH⁺ - C₄H₈], 622.4 (100) [MH⁺]. – **IR** (neat) [cm⁻¹]: $\tilde{\nu}$ = 2978, 2940, 2870, 2833, 1688, 1660, 1506, 1365, 1246, 1159, 1140, 1094, 1046, 862, 790. – **MF** C₃₀H₄₇N₅O₇S. – **MW** 622.79.

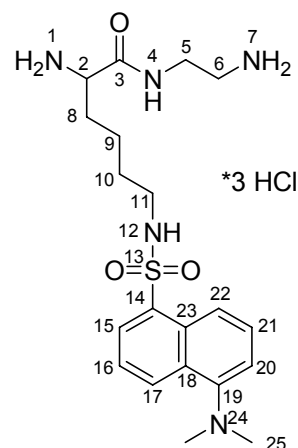

2-Amino-N-(2-aminoethyl)-6-(5-(dimethylamino)naphthalene-1-sulfonamido)hexanamide · 3 HCl (45):

Compound **85** (1.00 g, 1.61 mmol) was dissolved in methanol and cooled to 0 °C in an ice bath. To the solution HCl saturated diethyl ether (0.7 ml/mmol Boc-group) was added. The mixture was allowed to warm to room temperature and stirred over night. The reaction progress was monitored by $^1\text{H-NMR}$. The mixture was concentrated under reduced pressure and dried under high vacuum to obtain the product as colorless solid in 92 % yield (760 mg, 1.47 mmol).

MP > 180 °C. – **$^1\text{H-NMR}$** (300 MHz, $\text{MeOH-}d_4$): δ = 1.35-1.58 (m, 4 H, 9 + 10), 1.73-1.92 (m, 2 H, 8), 2.89 (t, $^3J_{\text{H,H}}$ = 6.6, 2 H, 11), 3.04-3.21 (m, 2 H, 6), 3.38-3.49 (m, 1 H, 5), 3.53 (s, 6 H, 24), 3.57-3.69 (m, 1 H, 5), 3.88 (t, $^3J_{\text{H,H}}$ = 6.6, 2 H, 2), 7.86-7.97 (m, 2 H, H-Ar), 8.18 (d, $^3J_{\text{H,H}}$ = 7.4, 1 H, H-Ar), 8.39 (dd, $^3J_{\text{H,H}}$ = 0.4, $^3J_{\text{H,H}}$ = 7.0, 1 H, H-Ar), 8.65 (d, $^3J_{\text{H,H}}$ = 8.8, 1 H, H-Ar), 8.97 (d, $^3J_{\text{H,H}}$ = 8.8, 1 H, H-Ar). – **$^{13}\text{C-NMR}$** (75 MHz, $\text{MeOH-}d_4$): δ = 22.6 (-, 1 C, CH_2), 29.1 (-, 1 C, 10), 34.0 (-, 1 C, 8), 36.6 (-, 1 C, 5/6), 39.2 (-, 1 C, 5/6), 42.7 (-, 1 C, 11), 45.4 (+, 2 C, 25), 54.8 (+, 1 C, 2), 115.2 (+, 1 C, Ar-CH), 119.0 (+, 1 C, Ar-CH), 123.2 (+, 1 C, Ar-CH), 128.2 (+, 1 C, Ar-CH), 129.1 (+, 1 C, Ar-CH), 129.6 (C_{quat} , 1 C, Ar-C), 129.8 (C_{quat} , 1 C, Ar-C), 130.2 (+, 1 C, Ar-CH), 135.1 (C_{quat} , 1 C, Ar-C), 151.1 (C_{quat} , 1 C, 19), 174.0 (C_{quat} , 1 C, 3). – **MS** (ES, DCM/MeOH + 10 mmol/l NH_4OAc): m/z (%) = 231.9 (100) [$\text{M} + 2\text{H}^+$], 422.0 (24) [MH^+]. – **IR** (neat) [cm^{-1}]: $\tilde{\nu}$ = 2943, 2864, 2832, 2793, 1655, 1574, 1307, 1139, 1092, 1075, 911, 789, 725. – **MF** $\text{C}_{20}\text{H}_{31}\text{N}_5\text{O}_3\text{S} \cdot 3 \text{HCl}$. – **MW** 530.94.

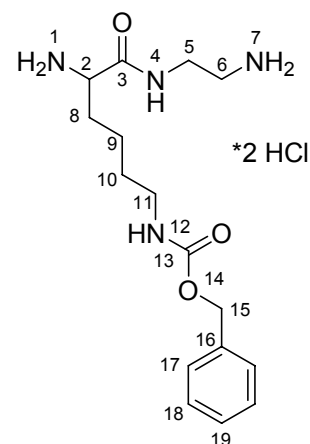

Benzyl 5-amino-6-(2-aminoethylamino)-6-oxohexylcarbamate · 2 HCl (48):

Compound **85** (500 mg, 0.96 mmol) was dissolved in methanol and cooled to 0 °C in an ice bath. To the solution HCl saturated diethyl ether (0.7 ml/mmol Boc-group) was added. The mixture was allowed to warm to room temperature and stir over night. The reaction progress was controlled by ¹H-NMR. The mixture was concentrated under reduced pressure and dried under high vacuum to obtain the product as colorless solid in quantitative yield (379 mg, 0.96 mmol).

MP > 180 °C. – **¹H-NMR** (300 MHz, MeOH-*d*₄): δ = 1.45-1.61 (m, 2 H, 10), 1.67-1.81 (m, 2 H, 9), 1.84-2.03 (m, 2 H, 8), 2.98 (t, ³J_{H,H} = 7.6, 2 H, 11), 3.05-3.24 (m, 2 H, 6), 3.44 (dt, ²J_{H,H} = 15.0, 1 H, ³J_{H,H} = 6.2, 1 H, 1 H, 5), 3.69 (ddd, ²J_{H,H} = 5.3, ³J_{H,H} = 7.2, ²J_{H,H} = 14.5, 1 H, 5), 3.97 (t, ³J_{H,H} = 6.7, 2 H, 2), 5.49 (s, 2 H, 15), 7.26-7.43 (m, 5 H, H-Ar). – **¹³C-NMR** (75 MHz, MeOH-*d*₄): δ = 23.2 (-, 1 C, 9), 28.0 (-, 1 C, 10), 31.8 (-, 1 C, 8), 38.3 (-, 1 C, 5/6), 40.4 (-, 1 C, 5/6), 40.6 (-, 1 C, 11), 54.5 (+, 1 C, 2), 67.0 (-, 1 C, 15), 129.4-129.8 (+, 5 C, 17-19), 139.4 (C_{quat}, 1 C, 16), 163.8 (C_{quat}, 1 C, 13), 171.3 (C_{quat}, 1 C, 3). – **MS** (ES, MeCN + 0.059 % TFA): *m/z* (%) = 182.7 (38) [M + MeCN + 2H⁺], 203.0 (31) [M + 2 MeCN + 2 H⁺], 323.1 (100) [MH⁺]. – **IR** (neat) [cm⁻¹]: $\tilde{\nu}$ = 2940, 2862, 2829, 2796, 1652, 1574, 1304, 1140, 1092, 1075, 909, 789. – **MF** C₁₆H₂₆N₄O₃ · 2 HCl. – **MW** 395.33.

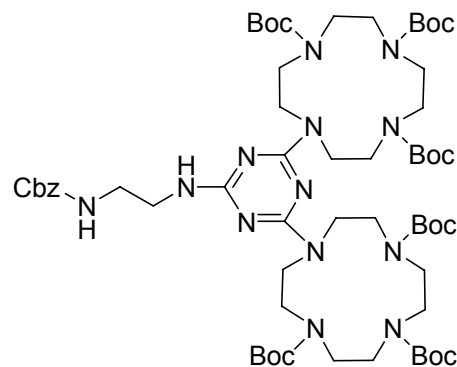

Hexa-tert-butyl 10,10'-(6-(2-(benzyloxycarbonylamino)ethylamino)-1,3,5-triazine-2,4-diyl)bis(1,4,7,10-tetraazacyclododecane-1,4,7-tricarboxylate) (**51**):

Benzyl 2-aminoethylcarbamate **50** (1.47 g, 7.6 mmol) was suspended in dioxane and potassium carbonate (42 g, 0.30 mol) was added. The mixture was stirred for half an hour, then compound **15** (5.0 g, 4.7 mmol) was added and the solution was refluxed for three days under vigorous stirring. The potassium carbonate was filtered off and the solution was evaporated to dryness. The crude product was purified by chromatography on silica gel with PE:EtOAc 80:20 (R_f (PE:EtOAc 1:1) = 0.47) as eluent to give the product as a colorless solid (4.8 g, 4.0 mmol, 84 %).

MP 134-135 °C. – **¹H-NMR** (300 MHz, CDCl₃): δ = 1.22-1.56 (m, 54 H, Boc-CH₃), 2.81-3.88 (m, 36 H, Cyclen-CH₂ + NH-CH₂-CH₂), 4.88 (s, 1 H, NH), 5.05 (s, 2 H, CH₂-Cbz), 6.67 (s, 1 H, NH), 7.27-7.37 (m, 5 H, CH-Cbz). – **¹³C-NMR** (75 MHz, CDCl₃): δ = 28.5 (+, 18 C, Boc-CH₃), 40.2 (-, 1 C, NH-CH₂), 41.0 (-, 1 C, NH-CH₂), 49.5-51.1 (-, 16 C, Cyclen-CH₂), 66.4 (-, 1 C, CH₂-Cbz), 79.8 (C_{quat}, 6 C, OC(CH₃)₃), 127.9 (+, 1 C, CH-Cbz), 128.2 (+, 1 C, CH-Cbz), 128.3 (+, 1 C, CH-Cbz), 136.9 (C_{quat}, 1 C, C-Ar-Cbz), 155.9-157.4 (C_{quat}, 7 C, Boc-CO + Cbz-CO), 166.0 (C_{quat}, 3 C, Ar-C). – **MS** (ES, DCM/MeOH + 10 mmol/l NH₄OAc): m/z (%) = 1214.9 (100) [MH⁺]. – **Elemental Analysis** calcd. (%) for C₄₉H₉₉N₁₃O₁₄ (1214.50): C 58.35, H 8.22, N 14.99. - found: C 58.33, H 8.19, N 14.79. – **IR** (neat) [cm⁻¹]: $\tilde{\nu}$ = 3350, 2974, 2932, 1685, 1538, 1409, 1364, 1246, 1158, 1105, 972, 776. – **MF** C₄₉H₉₉N₁₃O₁₄. – **MW** 1214.50.

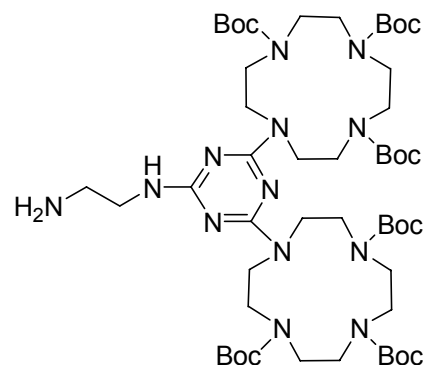

Hexa-tert-butyl 10,10'-(6-(2-aminoethylamino)-1,3,5-triazine-2,4-diyl)bis(1,4,7,10-tetraaza-cyclododecane-1,4,7-tricarboxylate) (52):

Compound **51** (4.8 g, 4.0 mmol) was dissolved in methanol. To this mixture a spatula of palladium on activated charcoal was added (10 % Pd). The mixture was stirred at 30 bars of H₂ pressure for three days. The charcoal was filtered off. The mixture was concentrated under reduced pressure and dried under high vacuum to obtain the product as a colorless solid in 79 % yield (3.4 g, 3.1 mmol). No further purification was necessary.

MP 126-127 °C. – **¹H-NMR** (300 MHz, CDCl₃): δ = 1.29-1.58 (m, 54 H, Boc-CH₃), 2.85-2.96 (m, 2 H, CH₂-NH₂), 3.13-3.86 (m, 34 H, Cyclen-CH₂ + CH₂-CH₂-NH₂). – **¹³C-NMR** (75 MHz, CDCl₃): δ = 28.5 (+, 18 C, Boc-CH₃), 41.7 (-, 1 C, CH₂), 43.0 (-, 1 C, CH₂), 50.3 (-, 16, Cyclen-CH₂), 79.9 (C_{quat}, 6 C, Boc- C_{quat}), 156.5 (C_{quat}, 6 C, Boc-CO), 166.1 (C_{quat}, 3 C, C-Ar). – **MS** (ES, DCM/MeOH + 10 mmol/l NH₄OAc): *m/z* (%) = 1081.1 (100) [MH⁺]. – **IR** (neat) [cm⁻¹]: $\tilde{\nu}$ = 2973, 2930, 1686, 1539, 1466, 1408, 1364, 1247, 1159, 1105, 971, 776. – **MF** C₅₁H₉₃N₁₃O₁₂. – **MW** 1080.36.

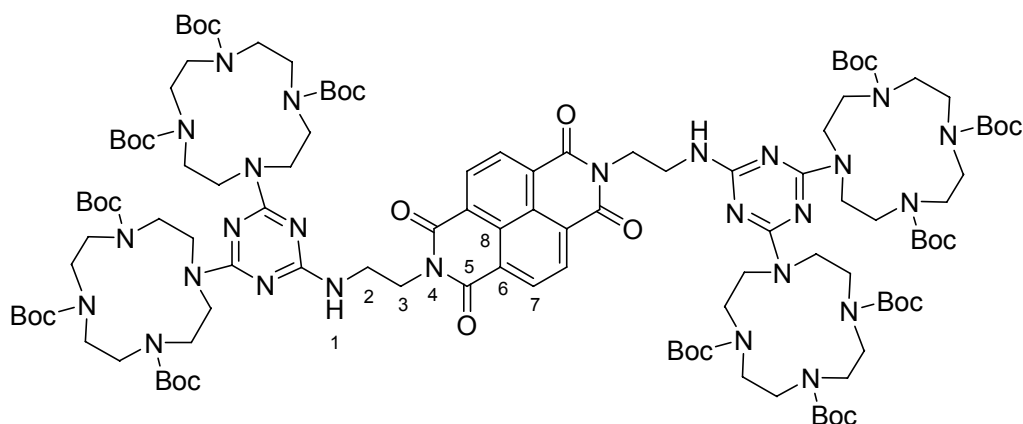
**Compound 53:**

Compound **27** (975 mg, 0.90 mmol) was suspended in 20 ml of toluene and diisopropylethyl amine (170 μ l, 0.99 mmol) was added. The mixture was stirred for half an hour then compound **52** (110 mg, 0.41 mmol) was added and the solution was stirred for one day at 100 °C. After filtration of the mixture, the solution was concentrated under reduced pressure and the crude product was purified via flash-chromatography on silica gel with EtOAc (R_f = 0.69) as eluent to give the product as pale yellow solid (940 mg, 0.39 mmol, 94 %).

MP 178-180 °C. – **¹H-NMR** (300 MHz, $CDCl_3$): δ = 1.29-1.60 (m, 108 H, Boc- CH_3), 3.12-4.02 (m, 68 H, Cyclen- CH_2 + 2), 4.41 (s, 4 H, 3), 4.93-5.22 (m, 2 H, 1), 8.74 (s, 4 H, 7). – **¹³C-NMR** (75 MHz, $CDCl_3$): δ = 28.5 (+, 36 C, Boc- CH_3), 40.4 (-, 2 C, 2), 50.3 (-, 32 C, Cyclen- CH_2), 51.0 (-, 2 C, 3), 79.7 (C_{quat} , 12 C, $OC(CH_3)_3$), 126.6 (C_{quat} , 4 C, 6), 126.8 (C_{quat} , 2 C, 8), 131.1, 126.6 (+, 4 C, 7), 155.7-157.0 (C_{quat} , 12 C, Boc-CO), 162.9 (C_{quat} , 4 C, 5), 165.9 (C_{quat} , 6 C, triacene-C). – **MS** (ES, DCM/MeOH + 10 mmol/l NH_4OAc): m/z (%) = 1197.6 (100) [$M + 2 H^+$], 2394.3 (7) [MH^+]. – **Elemental analysis** calcd. (%) for $C_{116}H_{186}N_{26}O_{28}$ (2392.88) + EtOAc: C 58.09, H 7.88, N 14.68; found: C 58.08, H 7.96, N 14.26. – **IR** (neat) [cm^{-1}]: $\tilde{\nu}$ = 2977, 2928, 1688, 1667, 1536, 1495, 1466, 1408, 1364, 1244, 1157, 1105, 972, 771. – **UV/VIS** (MeCN): λ (lg ϵ) = 338 nm (4.066), 356 nm (4.272), 376 nm (4.311). – **MF** $C_{116}H_{186}N_{26}O_{28}$. – **MW** 2392.88.

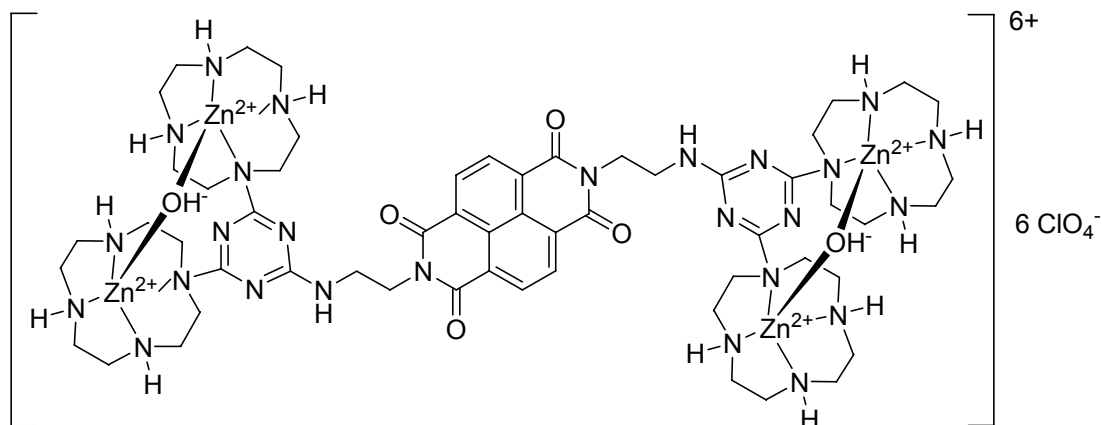

Complex 55:

Compound **53** (144 mg, 0.06 mmol) was dissolved in methanol and cooled to 0 °C in an ice bath. To the solution HCl saturated diethyl ether (0.7 ml/mmol Boc-group) was added. The mixture was allowed to warm to room temperature and was stirred over night. The solvent was evaporated and the crude product was dissolved in water and purified over an ion exchanger column using a strongly basic ion exchange resin (OH⁻-form, loading 0.9 mmol/ml, 4 eq. per protonated nitrogen) to give a colorless solid after freeze drying. Two solutions one containing the obtained colorless solid from the column in water and a second containing Zn(ClO₄)₂ · 6 H₂O (96 mg, 0.26 mmol, 4.4 eq. per deprotected receptor) in absolute ethanol were prepared. These two solutions were then simultaneously added drop wise to 80 °C hot water under vigorous stirring. The resulting mixture was stirred at 90 °C over night. The solution was freeze dried and the product was recrystallized from a water methanol mixture to give the complex as ocher solid in 64 % yield. (85 mg, 0.04 mmol).

MP > 180 °C. – **MS** (ES, DCM/MeOH + 10 mmol/l NH₄OAc) (K⁸⁺ = C₅₆H₉₀N₂₆O₄Zn₄) : *m/z* (%) = 420.8 (100) [K⁸⁺ + 4 CH₃COO⁻], 541.3 (44) [K⁸⁺ - 2 H⁺ + 3 CH₃COO⁻], 560.7 (100) [K⁸⁺ - H⁺ + 4 CH₃COO⁻], 566.7 (49) [K⁸⁺ + OH⁻, 4 CH₃COO⁻], 580.7 (73) [K⁸⁺ + 5 CH₃COO⁻], 594.0 (40) [K⁸⁺ + 4 CH₃COO⁻ + ClO₄⁻]. – **IR** (neat) [cm⁻¹]: $\tilde{\nu}$ = 3374, 3289, 3268, 2941, 2896, 1698, 1659, 1539, 1424, 1343, 1070, 965, 807, 769, 621. – **UV/VIS** (HEPES pH 7.4): λ (lg ϵ) = 362 nm (4.178), 383 nm (4.176). – **MF** [C₅₆H₉₀N₂₆O₄Zn₄]⁸⁺(ClO₄)₆(OH)₂. – **MW** 2083.74.

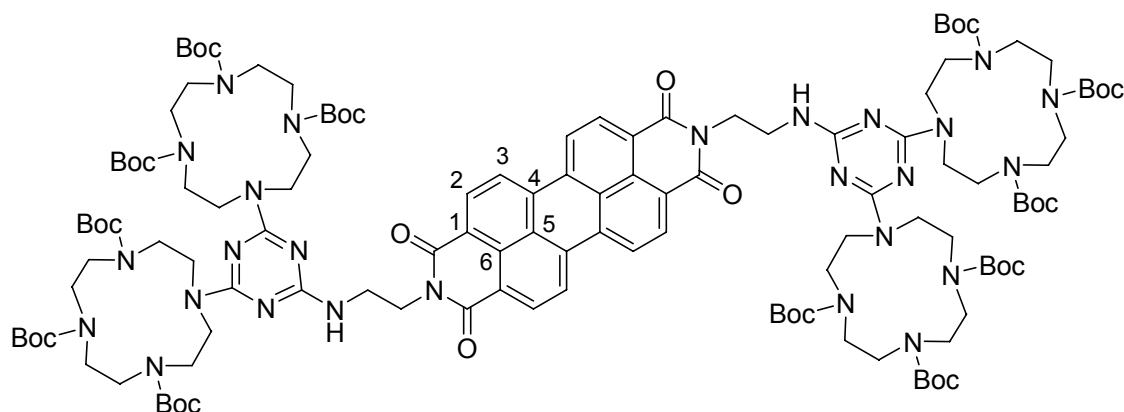
**Compound 54:**

Compounds **52** (991 mg, 0.92 mmol) and **28** (150 mg, 0.38 mmol) were mixed with 4 g of imidazole and filled into a Schlenk tube. Under an atmosphere of nitrogen the mixture was melted with a heat gun and then put into an oil bath where it was stirred at 120 °C for one day. The hot melt was poured into 20 ml of water and the product was extracted three times with 15 ml EtOAc. The combined organic layers were dried over MgSO₄ and concentrated under reduced pressure. The crude product was purified by flash-chromatography on silica gel with DCM:MeOH 97:3 ($R_{f(\text{DCM:MeOH } 97:3)} = 0,28$) as eluent to give the product as dark red solid (1.53 g, 0.71 mmol, 68 %).

MP 175-176 °C. – **¹H-NMR** (300 MHz, CDCl₃): δ = 1.23-1.53 (m, 108 H, Boc-CH₃), 2.66-3.92 (m, 68 H, Cyclen-CH₂ + CH₂), 4.39 (bs, 4 H, CH₂), 5.30 (bs, 2 H, NH), 8.30 (d, $^3J_{\text{H,H}} = 7.41$, 4 H, 2), 8.43 (d, $^3J_{\text{H,H}} = 7.68$, 4 H, 3). – **¹³C-NMR** (75 MHz, CDCl₃): δ = 28.5 (+, 36 C, Boc-CH₃), 39.5 (-, 2 C, CH₂), 40.1 (-, 2 C, CH₂), 49.5-51.5 (-, 32 C, Cyclen-CH₂), 79.7 (C_{quat}, 12 C, OC(CH₃)₃), 122.9 (C_{quat}, 2 C, 6), 123.2 (+, 4 C, 3), 125.9 (C_{quat}, 2 C, 5), 129.0 (C_{quat}, 4 C, 1), 131.2 (+, 4 C, 2), 134.2 (C_{quat}, 4 C, 4), 155.5-157.4 (C_{quat}, 12 C, Boc-CO), 163.3 (C_{quat}, 4 C, 5), 166.0 (C_{quat}, 6 C, Triacene-C). – **MS** (ES, DCM/MeOH + 10 mmol/l NH₄OAc): m/z (%) = 1259.6 (100) [M + 2 H⁺]. – **Elemental analysis** calcd. (%) for C₁₂₆H₁₉₀N₂₆O₂₈ (2517.01) + 2 H₂O: C 59.28, H 7.66, N 14.26; found: C 59.32, H 7.67, N 14.01. – **IR** (neat) [cm⁻¹]: $\tilde{\nu}$ = 3297, 2986, 2942, 2928, 2898, 2366, 2336, 1697, 1655, 1542, 1476, 1419, 1349, 1061, 1049, 965, 811, 738, 620. – **UV/VIS** (MeCN): λ (lg ϵ) = 456 nm (3.873), 484 nm (4.355), 521 nm (4.497). – **MF** C₁₂₆H₁₉₀N₂₆O₂₈ – **MW** 2517.01.

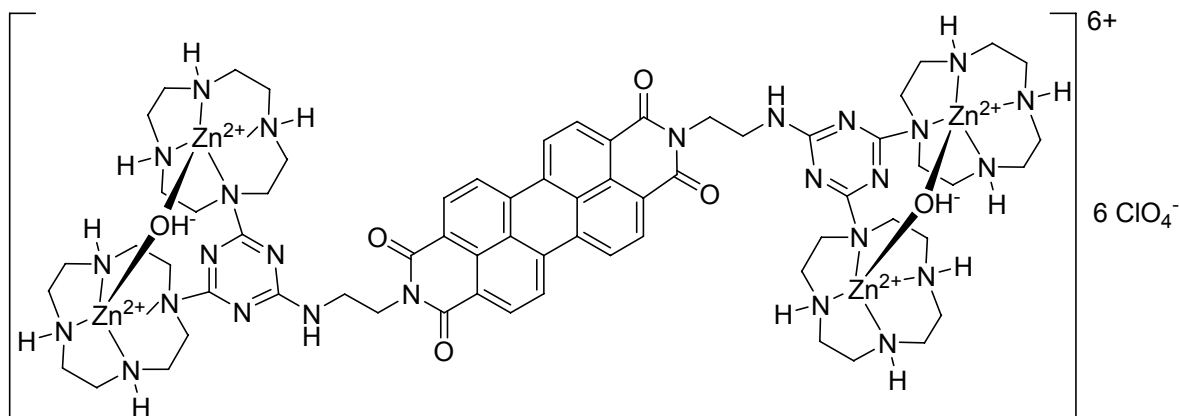

Complex 56:

Compound **54** (230 mg, 0.09 mmol) was dissolved in methanol and cooled to 0 °C in an ice bath. To the solution HCl saturated diethyl ether (0.7 ml/mmol Boc-group) was added. The mixture was allowed to warm to room temperature and was stirred over night. The solvent was evaporated and the crude product was dissolved in water and purified over an ion exchanger column using a strongly basic ion exchange resin (OH⁻-form, loading 0.9 mmol/ml, 4 eq. per protonated nitrogen) to give a colorless solid after freeze drying. Two solutions one containing the obtained colorless solid from the column in water and a second containing Zn(ClO₄)₂ · 6 H₂O (125 mg, 0.33 mmol, 4.4 eq. per deprotected receptor) in absolute ethanol were prepared. These two solutions were simultaneously added drop wise to 80 °C hot water under vigorous stirring. The resulting mixture was stirred at 90 °C over night. The solution was freeze dried and the product was recrystallized from a water methanol mixture to give the complex as violet red solid in 60 % yield. (118 mg, 0.05 mmol)

MP > 180 °C. – **MS** (ES, H₂O/MeOH + 10 mmol/l NH₄OAc) (K⁸⁺ = C₆₆H₉₂N₂₆O₄Zn₄) : *m/z* (%) = 436.3 (35) [K⁸⁺ - H⁺ + 3 CH₃COO⁻], 451.8 (100) [K⁸⁺ + 4 CH₃COO⁻], 602 (48) [K⁸⁺ - H⁺ + 4 CH₃COO⁻], 608.0 (32) [K⁸⁺ + OH⁻ + 4 CH₃COO⁻], 621.5 (36) [K⁸⁺ + 5 CH₃COO⁻]. – **IR** (neat) [cm⁻¹]: $\tilde{\nu}$ = 3276, 2926, 1692, 1654, 1558, 1438, 1361, 1347, 1089, 964, 810, 746. – **UV/VIS** (HEPES pH 7.4): λ (lg ϵ) = 500 nm (3.733), 538 nm (3.844). – **MF** [C₆₆H₉₄N₂₆O₄Zn₄]⁸⁺(ClO₄)₆(OH)₂. – **MW** 2207.88.

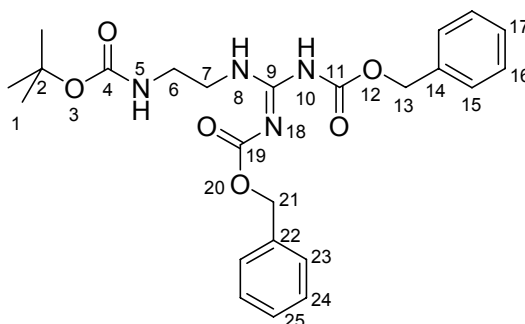

tert-Butyl 2-(2,3-bis(Cbz)guanidino) ethylcarbamate (86):

Tert-butyl 2-aminoethylcarbamate **33** (335 mg, 2.09 mmol) was dissolved in dioxane and triethylamine (0.58 ml, 4.19 mmol) was added. The mixture was stirred for 10 minutes. Then 1,3-bis(Cbz)-2-methyl-2-thiopseudourea **57** (500 mg, 1.40 mmol) was added and the mixture was stirred for 100 min at room temperature. The reaction process was controlled by TLC. The reaction mixture was uptaken in water and extracted three times with DCM. Afterwards the solution was dried over MgSO₄ and concentrated under reduced pressure. The crude product was purified by column chromatography on silica gel (EtOAc:PE 1:1, R_f = 0,56). The pure product was obtained as colorless solid in 91 % yield. (600 mg, 1.28 mmol)

MP 80-83 °C. – **¹H-NMR** (300 MHz, CDCl₃): δ = 3.25-3.39 (m, 2 H, 6), 3.50-3.61 (m, 2 H, 7), 5.06 (s, 1 H, 5), 5.13 (s, 2 H, 13/21), 5.17 (s, 2 H, 13/21), 7.27-7.44 (m, 10 H, 15-17 + 23-25), 8.54 (s, 1 H, 8), 11.77 (s, 1 H, 10). – **¹³C-NMR** (75 MHz, CDCl₃): δ = 28.3 (+, 3 C, 1), 40.2 (-, 1 C, 6), 41.3 (-, 1 C, 7), 67.3 (-, 1 C, 10/18), 68.3 (-, 1 C, 10/18), 79.5 (C_{quat.}, 1 C, 2), 128.0-128.9 (+, 10 C, 15-17 + 23-25), 134.6 (C_{quat.}, 1 C, 14/22), 136.6 (C_{quat.}, 1 C, 14/22), 153.6 (C_{quat.}, 1 C, 11/19), 156.1 (C_{quat.}, 1 C, 9), 156.3 (C_{quat.}, 1 C, 4), 163.3 (C_{quat.}, 1 C, 11/19). – **MS** (ES, DCM/MeOH + 10 mmol/l NH₄OAc): *m/z* (%) = 471 (100) [MH⁺]. – **IR** (neat) [cm⁻¹]: $\tilde{\nu}$ = 3133, 2964, 1762, 1736, 1668, 1592, 1496, 1264, 1241, 1206, 1155, 1061, 981, 915, 790, 772, 735, 693. – **MF** C₂₄H₃₀N₄O₆. – **MW** 470.52.

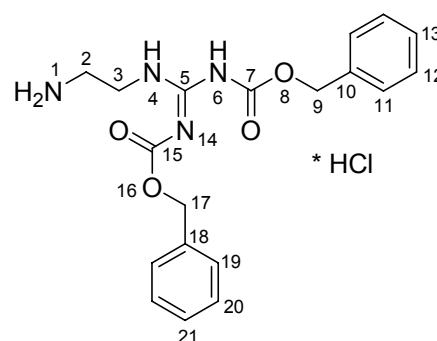

1-(2-Aminoethyl)-2,3-di(Boc)guanidine·HCl (58):

Tert-butyl 2-(2,3-bis(Cbz)guanidino) ethylcarbamate **86** (600 mg, 1.28 mmol) was dissolved in DCM and cooled to 0 °C in an ice bath. To this solution 6 ml of HCl saturated diethyl ether were added. The mixture was allowed to warm to room temperature and stirred over night. The reaction progress was monitored by ¹H-NMR. The solvent was evaporated under reduced pressure to obtain the hydrochloride salt of the product as colorless solid in quantitative yield (521 mg, 1.28 mmol).

MP > 180 °C. – **¹H-NMR** (300 MHz, MeOH-*d*₄): δ = 3.25 (t, ³J_{H,H} = 6.0, 2 H, 2), 3.85 (t, ³J_{H,H} = 5.9, 2 H, 3), 5.31 (s, 2 H, 9/17), 5.34 (s, 2 H, 9/17), 7.29-7.53 (m, 10 H, 11-13 + 19-21). – **¹³C-NMR** (75 MHz, MeOH-*d*₄): δ = 39.5 (-, 1 C, 2), 41.6 (-, 1 C, 3), 67.3 (-, 1 C, 9/17), 70.7 (-, 1 C, 9/17), 128.8-130.1 (+, 10 C, 11-13 + 19-21), 136.1 (C_{quat.}, 1 C, 10/18), 138.4 (C_{quat.}, 1 C, 10/18), 153.7 (C_{quat.}, 1 C, 7/15), 155.6 (C_{quat.}, 1 C, 7/15), 156.3 (C_{quat.}, 1 C, 5). – **MS** (ESI, MeCN/Water + 0.0059 % TFA): *m/z* (%) = 371.0 (100) [MH⁺], 741.4 (17) [M + 2 H⁺]. – **IR** (neat) [cm⁻¹]: $\tilde{\nu}$ = 3137, 2961, 1763, 1737, 1669, 1592, 1497, 1457, 1408, 1338, 1274, 1241, 1217, 1156, 1062, 982, 916, 792, 736, 694. – **MF** C₁₉H₂₂N₄O₄ · HCl. – **MW** 406.87.

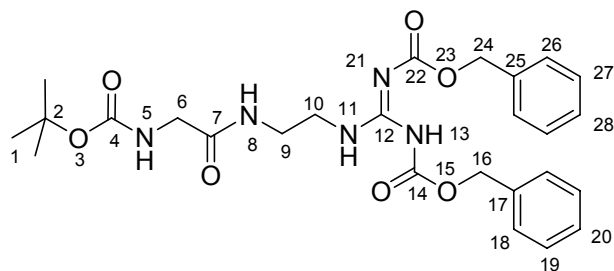
**Compound 87:**

Boc-Gly-OH **32** (744 mg, 4.25 mmol), HOBt (867 mg, 6.37 mmol) and DIPEA (2.18 ml, 12.7 mmol) were dissolved in DMF (20 ml). The mixture was cooled to 0 °C in an ice bath and EDC (1.13 ml, 6.37 mmol) was added. Then compound **58** (1.50 g, 3.54 mmol) was added slowly in portions. The reaction was monitored by TLC (EtOAc). After 24 hours the solution was uptaken in water and extracted with DCM. The combined organic layers were washed twice with an aqueous citric acid solution (10 %) and twice with brine. Afterwards the solution was dried over MgSO₄ and concentrated under reduced pressure. The crude product was purified by column chromatography on silica gel (EtOAc, R_f = 0.41) to give the product as colorless solid (1.55 g, 2.94 mmol, 83 %).

MP 122 - 124 °C. – **¹H-NMR** (300 MHz, CDCl₃): δ = 1.44 (s, 9 H, 1), 1.78 (s, 1 H, NH), 3.40-3.50 (m, 2 H, CH₂), 3.51-3.62 (m, 2 H, CH₂), 3.69-3.78 (m, 2 H, CH₂), 5.12 (s, 2 H, CH₂-Bzl), 5.19 (s, 2 H, CH₂-Bzl), 7.21 (s, 1 H, NH), 7.40-7.52 (m, 10 H, CH-Ar), 8.59 (s, 1 H, NH), 11.67 (s, 1 H, NH). – **¹³C-NMR** (75 MHz, CDCl₃): δ = 28.3 (+, 3 C, 1), 39.8 (-, 1 C, 10), 40.7 (-, 1 C, 9), 44.1 (-, 1 C, 6), 67.3 (-, 1 C, 16), 68.4 (-, 1 C, 24), 80.0 (C_{quat}, 1 C, 2), 127.8-128.9 (+, 10 C, CH-Ar), 134.5 (C_{quat}, 1 C, 17/25), 136.5 (C_{quat}, 1 C, 17/25), 153.6 (C_{quat}, 1 C, 4/14/22), 156.0 (C_{quat}, 1 C, 4/14/22), 156.9 (C_{quat}, 1 C, 4/14/22), 163.3 (C_{quat}, 1 C, 12), 170.2 (C_{quat}, 1 C, 7). – **MS** (ESI, MeCN/Water + 0.0059 % TFA): *m/z* (%) = 528.1 (100) [MH⁺], 1055.7 (10) [M + 2 H⁺]. – **IR** (neat) [cm⁻¹]: $\tilde{\nu}$ = 3340, 3298, 1726, 1639, 1586, 1534, 1380, 1317, 1269, 1217, 1150, 1128, 1055, 916, 811, 769, 745, 695, 658. – **MF** C₂₆H₃₃N₅O₇. – **MW** 527.57.

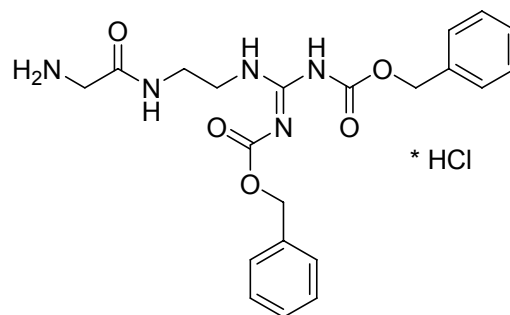
**Compound 59:**

Compound **87** (775 mg, 1.47 mmol) was dissolved in DCM and cooled to 0 °C in an ice bath. To this solution 8.5 ml of HCl saturated diethyl ether were added. The mixture was allowed to warm to room temperature and stirred over night. The reaction progress was monitored by ¹H-NMR. The solvent was evaporated under reduced pressure to give the hydrochloride salt of the product as colorless solid in quantitative yield (681 mg, 1.47 mmol).

MP > 180 °C. – **¹H-NMR** (300 MHz, MeOH-*d*₄): δ = 3.51 (bs, 2 H, CH₂), 3.77 (bs, 2 H, CH₂), 4.59 (s, 2 H, CH₂), 5.26 (s, 2 H, Bzl-CH₂), 5.33 (s, 2 H, Bzl-CH₂), 7.22-7.52 (m, 10 H, Ar-CH). – **¹³C-NMR** (75 MHz, MeOH-*d*₄): δ = 41.8 (-, 1 C, CH₂), 42.4 (-, 1 C, CH₂), 48.3 (-, 1 C, CH₂), 70.0 (-, 1 C, Bzl-CH₂), 70.9 (-, 1 C, Bzl-CH₂), 128.8-130.2 (+, 10 C, Ar-CH), 135.9 (C_{quat.}, 1 C, Ar-C), 139.9 (C_{quat.}, 1 C, Ar-C), 153.6 (C_{quat.}, 1 C, CNH), 154.3 (C_{quat.}, 1 C, Cbz-CO), 154.5 (C_{quat.}, 1 C, Cbz-CO), 168.4 (C_{quat.}, 1 C, CONH). – **MS** (ESI, MeCN/Water + 0.0059 % TFA): *m/z* (%) = 255.4 (34) [M + 2 H⁺ + 2 MeCN], 428.0 (100) [MH⁺], 855.5 (11) [M + 2 H⁺]. – **IR** (neat) [cm⁻¹]: $\tilde{\nu}$ = 2959, 1762, 1736, 1670, 1592, 1495, 1457, 1408, 1337, 1276, 1242, 1213, 1061, 985, 917, 789, 733, 692. – **MF** C₂₁H₂₅N₅O₅ · HCl. – **MW** 463.92.

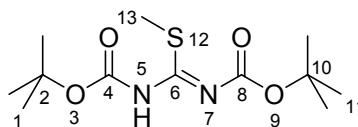

1,3-Bis(Boc)-2-methyl-2-thiopseudourea (63):

Literature known compound but improved synthesis.¹²¹

S-Methylisothiurea sulfate **61** (2.50 g, 18.0 mmol) and di-tert-butyl dicarbonate **62** (9.41 g, 43.1 mmol) were dissolved in 40 ml of a 1:1 mixture of DCM and saturated NaHCO₃ solution. The mixture was vigorously stirred at room temperature for three days. The organic layer was separated off and the aqueous solution was extracted two times with DCM. The combined organic layers were dried over MgSO₄ and the solvent was evaporated under reduced pressure. The crude product was purified by column chromatography on silica gel using (EE:PE 10:90, R_f = 0.46) to give the product as colorless solid (5.11 g, 17.6 mmol, 98 %).

MP 112-114 °C. – **¹H-NMR** (300 MHz, CDCl₃): δ = 1.51 (s, 18 H, 1 + 11), 2.40 (s, 3 H, 13), 11,06 (bs, 1 H, NH). – **¹³C-NMR** (75 MHz, CDCl₃): δ = 14.4 (+, 1 C, 13), 28.3 (+, 6 C, 1 + 11), 81.1 (C_{quat}, 1 C, 2), 83.2 (C_{quat}, 1 C, 10), 150.7 (C_{quat}, 1 C, 4), 160.9 (C_{quat}, 1 C, 8), 171.5 (C_{quat}, 1 C, 6). – **MS** (CI, NH₃): *m/z* (%) = 191 (22) [MH⁺ - C₄H₈ - CO₂], 291 (100) [MH⁺]. – **MF** C₁₂H₂₂N₂O₄S. – **MW** 290.38.

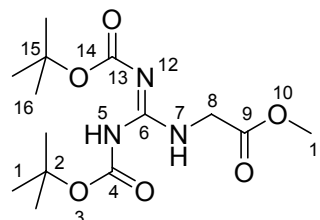

Compound 88:

H-Gly-OMe · HCl (**37**) (1.5 g, 12.1 mmol) was dissolved in dioxane and triethylamine (3.3 ml, 24 mmol) was added. The mixture was stirred for 10 min. Then 1,3-bis(Boc)-2-methyl-2-thiopseudourea (**63**) (2.5 g, 8.6 mmol) was added and the mixture was stirred for 30 h at room temperature. The reaction progress was monitored by TLC. The reaction mixture was dissolved in water and extracted three times with DCM. Afterwards the combined organic layers were dried over MgSO₄ and concentrated under reduced pressure. The crude product was purified by column chromatography on silica gel using PE:EtOAc 2:1 (R_f(PE: EtOAc 1:1) = 0,78) as eluent. The pure product was obtained as a colorless solid in 67 % yield. (1.9 g, 5.8 mmol)

MP 132-133 °C. – **¹H-NMR** (300 MHz, CDCl₃): δ = 1.49 (s, 9 H, 1/15), 1.50 (s, 9 H, 1/15), 3.77 (s, 3 H, 11), 4.23 (s, ³J_{H,H} = 4.9, 2 H, 8), 8.86 (s, 1 H, NH), 11.43 (s, 1 H, NH). –

¹³C-NMR (75 MHz, CDCl₃): δ = 28.2 (+, 6 C, 1 + 16), 42.7 (-, 1 C, 8), 52.5 (+, 1 C, 11), 79.6 (C_{quat}, 1 C, 2), 83.4 (C_{quat}, 1 C, 15), 152.9 (C_{quat}, 1 C, 4), 156.0 (C_{quat}, 1 C, 13), 163.2 (C_{quat}, 1 C, 6), 169.9 (C_{quat}, 1 C, 9). – **MS** (ES, DCM/MeOH + 10 mmol/l NH₄OAc): *m/z* (%) = 332.2 (100) [MH⁺], 663.5 (42) [2 M + H⁺]. – **IR** (neat) [cm⁻¹]: $\tilde{\nu}$ = 3318, 2982, 2952, 2362, 1757, 1725, 1614, 1292, 1138, 1094, 1060, 975, 811, 761. – **MF** C₁₄H₂₅N₃O₆. – **MW** 331.36.

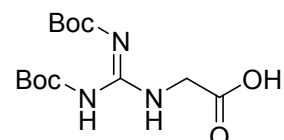

Compound 64:

Compound **88** (1.6 g, 4.7 mmol) was dissolved in a mixture of water and acetone 1:4. LiOH (0.17 g, 7.1 mmol) was added and the mixture was stirred at room temperature overnight. The solution was acidified with saturated NH₄Cl solution and extracted with DCM. The combined organic layers were dried over MgSO₄ and concentrated under reduced pressure to give the product as a colorless salt in quantitative yield. (1.5 g, 4.7 mmol)

MP 104-105 °C. – **¹H-NMR** (300 MHz, DMSO-*d*₆): δ = 1.39 (s, 9 H, Boc-CH₃), 1.49 (s, 9 H, Boc-CH₃), 3.98 (d, ³J_{H,H} = 5.4, 2 H, CH₂), 8.62 (s, 1 H, NH), 11.47 (s, 1 H, NH). – **¹³C-NMR** (75 MHz, DMSO-*d*₆): δ = 27.5 (+, 3 C, Boc-CH₃), 27.8 (+, 3 C, Boc-CH₃), 42.2 (-, 1 C, CH₂), 78.3 (C_{quat}, 1 C, C(CH₃)₃), 83.0 (C_{quat}, 1 C, C(CH₃)₃), 151.7 (C_{quat}, 1 C, Boc-CO), 155.2 (C_{quat}, 1 C, Boc-CO), 162.7 (C_{quat}, 1 C, C-NH), 170.4 (C_{quat}, 1 C, COO). – **MS** (ES, DCM/MeOH + 10 mmol/l NH₄OAc): *m/z* (%) = 206.1 (60) [MH⁺ - 2 C₄H₈], 262.2 (32) [MH⁺ - C₄H₈], 318.2 (100) [MH⁺], 635.5 (40) [2 M + H⁺]. – **IR** (neat) [cm⁻¹]: $\tilde{\nu}$ = 3329, 2978, 2932, 2362, 1795, 1726, 1633, 1398, 1319, 1229, 1144, 1102, 1060, 987, 883, 763. – **MF** C₁₃H₂₃N₃O₆. – **MW** 317.34.

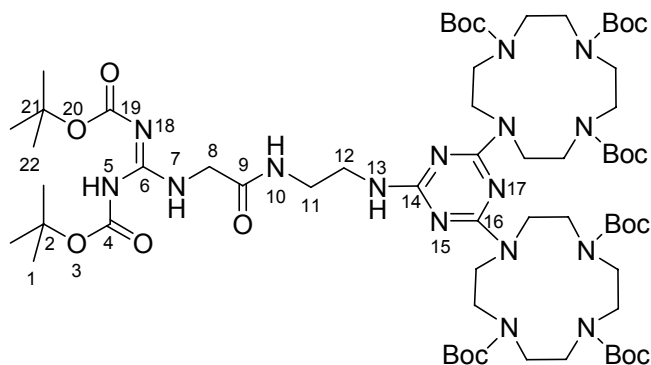
**Compound 65:**

The acid **64** (0.46 g, 1.4 mmol), HOBt (0.28 g, 2.1 mmol) and DIPEA (0.71 ml, 4.2 mmol) were dissolved under nitrogen atmosphere in dry DMF (10 ml). The mixture was cooled to 0 °C in an ice bath and EDC (0.37 ml, 2.1 mmol) was added. Then the amine **52** (1.0 g, 0.93 mmol) was added slowly in portions. The reaction progress was monitored by TLC (EtOAc). After 24 h water was added and extracted with DCM. The combined organic layers were washed three times with an aqueous citric acid solution (10 %) and twice with brine. Afterwards the solution was dried over MgSO₄ and concentrated under reduced pressure. The crude product was purified by flash chromatography on silica gel (PE:EtOAc 1:1, R_f = 0.43) to give the product as a colorless solid (0.33 g, 0.24 mmol, 25 %).

MP 158-159 °C. – **¹H-NMR** (300 MHz, CDCl₃): δ = 1.25-1.61 (m, 72 H, 1 + 22 + cyclen Boc-CH₃), 2.74-3.91 (m, 38 H, 8 + 11 + 12 + cyclen-CH₂), 4.92 (s, 1 H, NH), 7.53 (bs, 1 H, NH), 8.92 (s, 1 H, NH), 11.21 (s, 1 H, NH). – **¹³C-NMR** (75 MHz, CDCl₃): δ = 28.1-29.4 (+, 34 C, 1 + 22 + cyclen Boc-CH₃), 44.4 (-, 2 C, 8 + 11), 50.3 (-, 16 C, cyclen-CH₂), 54.9.2 (-, 2 C, 12), 79.9 (C_{quat}, 7 C, 2 + cyclen Boc-C_{quat}), 83.1 (C_{quat}, 1 C, 21), 152.7 (C_{quat}, 1 C, 4), 154.6-145.7 (C_{quat}, 7 C, 19 + cyclen Boc-CO), 163.2 (C_{quat}, 1 C, 6), 165.9 (C_{quat}, 3 C, 14 + 16), 168.4 (C_{quat}, 1 C, 9). – **MS** (ES, DCM/MeOH + 10 mmol/l NH₄OAc): *m/z* (%) = 690.7 (76) [M + 2 H⁺], 1380.2 (100) [MH⁺]. – **Elemental Analysis** calcd. (%) for C₆₄H₁₁₄N₁₆O₁₇ (1379.69) + 2 H₂O: C 54.30, H 8.40, N 15.83. - found: C 54.27, H 8.47, N 15.01. – **IR** (neat) [cm⁻¹]: $\tilde{\nu}$ = 3318, 2981, 2942, 2362, 1757, 1726, 1638, 1615, 1367, 1292, 1249, 1141, 1095, 1059, 975, 812, 774. – **MF** C₆₄H₁₁₄N₁₆O₁₇. – **MW** 1379.69.

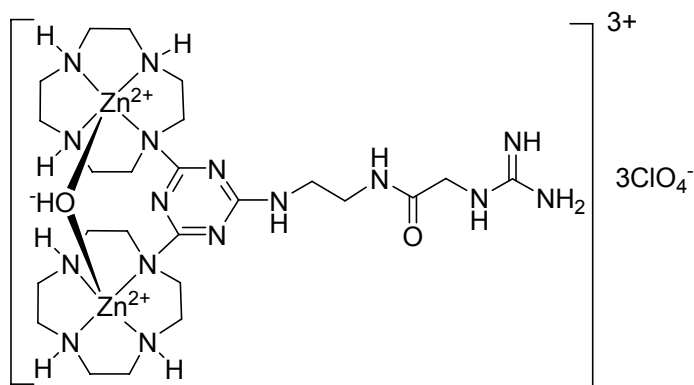
**Complex 66:**

Compound **65** (0.25 g, 0.18 mmol) was dissolved in methanol, cooled to 0 °C in an ice bath and HCl-saturated diethyl ether (0.7 ml/mmol Boc-group) was added. The mixture was allowed to warm to room temperature and was stirred over night. The solvent was evaporated. The crude product was dissolved in water and purified over an ion exchanger column using a strongly basic ion exchange resin (OH⁻-form, loading 0.9 mmol/ml, 4 eq. per protonated nitrogen) to give a colorless solid after freeze drying. Two aqueous solutions, one containing the obtained colorless solid from the column and a second containing Zn(ClO₄)₂ · 6 H₂O (0.15 g, 0.40 mmol) were prepared. These two solutions were simultaneously added to water at 80 °C. The resulting mixture was stirred at 90 °C over night. The solution was lyophilized and the product was recrystallized from a water methanol mixture to give the complex as a colorless solid in 83 % yield. (0.16 g, 0.15 mmol)

MP > 250 °C. – **MS** (ES, H₂O/MeOH + 10 mmol/l NH₄OAc) (K³⁺ = C₂₄H₅₁N₁₆O₂ClZn₂) : *m/z* (%) = 353.3 (62) [K³⁺ - H⁺ - H₂O], 363.8 (100) [K³⁺ - H⁺], 385.3 (71) [K³⁺ + OH⁻ + MeOH], 822.9 (19) [K³⁺ - H⁺ + ClO₄⁻]. – **IR** (neat) [cm⁻¹]: $\tilde{\nu}$ = 3568, 3527, 3370, 2942, 1625, 1548, 1480, 1421, 1342, 1285, 1063, 963, 814, 744. – **MF** [C₂₄H₅₀N₁₆OZn₂]⁴⁺(ClO₄)₃(OH). – **MW** 1024.89.

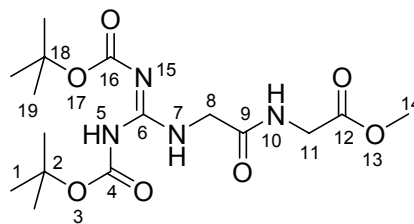
**Compound 89:**

Peptide H-Gly-Gly-OMe · HCl (**67**) (1.1 g, 6.2 mmol) was dissolved in CHCl₃:methanol 5:1 and triethylamine (1.7 ml, 12 mmol) was added. The mixture was stirred for 10 minutes. Then 1,3-bis(Boc)-2-methyl-2-thiopseudourea (**62**) (2.0 g, 6.9 mmol) was added and the mixture was stirred for 6 h at room temperature. The reaction progress was monitored by TLC. The reaction mixture was added to water and extracted three times with DCM. Afterwards the combined organic layers were dried over MgSO₄ and concentrated under reduced pressure. The crude product was purified by column chromatography on silica gel using PE:EtOAc 1:1 (R_f = 0,35) as eluent. The pure product was obtained as a colorless solid in 46 % yield. (1.1 g, 2.8 mmol)

MP 149-150 °C. – **¹H-NMR** (300 MHz, CDCl₃): δ = 1.42 (s, 9 H, 1/19), 1.43 (s, 9 H, 1/19), 3.69 (s, 3 H, 14), 4.00 (d, ³J_{H,H} = 5.2, 2 H, 9), 4.10 (d, ³J_{H,H} = 4.9, 2 H, 11), 6.98 (d, ³J_{H,H} = 4.9, 1 H, NH), 8.88 (t, ³J_{H,H} = 4.8, 1 H, NH), 11.32 (s, 1 H, NH). – **¹³C-NMR** (75 MHz, CDCl₃): δ = 28.2 (+, 6 C, 1 + 19), 41.3 (-, 1 C, 11), 44.4 (-, 1 C, 8), 52.4 (+, 1 C, 14), 79.6 (C_{quat}, 1 C, 2), 83.5 (C_{quat}, 1 C, 18), 152.8 (C_{quat}, 1 C, 4), 156.2 (C_{quat}, 1 C, 16), 163.0 (C_{quat}, 1 C, 6), 168.6 (C_{quat}, 1 C, 12), 170.0 (C_{quat}, 1 C, 9). – **MS** (CI, NH₃): *m/z* (%) = 389.0 (100) [MH⁺]. – **IR** (neat) [cm⁻¹]: $\tilde{\nu}$ = 3347, 3305, 2977, 2936, 2363, 1723, 1678, 1641, 1525, 1430, 1395, 1349, 1303, 1220, 1148, 1123, 1091, 1055, 971, 811. – **MF** C₁₆H₂₈N₄O₇. – **MW** 388.42.

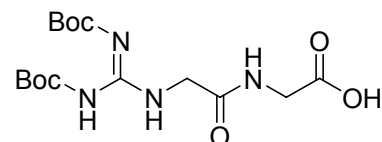
**Compound 68:**

Compound **89** (1.0 g, 2.6 mmol) was dissolved in a mixture of water and THF 1:4. LiOH (74 mg, 3.1 mmol) was added and the mixture was stirred at room temperature over night. The solution was acidified with 5 % aqueous KHSO₄ solution and extracted with DCM. The combined organic layers were dried over MgSO₄ and concentrated under reduced pressure to give the product as a colorless salt in 68 % yield. (0.64 g, 1.7 mmol)

MP 111-112 °C. – **¹H-NMR** (300 MHz, MeOH-*d*₄): δ = 1.46 (s, 9 H, Boc-CH₃), 1.53 (s, 9 H, Boc-CH₃), 3.78 (s, 2 H, CH₂), 4.09 (s, 2 H, CH₂). – **¹³C-NMR** (75 MHz, MeOH-*d*₄): δ = 28.6 (+, 3 C, Boc-CH₃), 29.0 (+, 3 C, Boc-CH₃), 44.6 (-, 1 C, CH₂), 45.0 (-, 1 C, CH₂), 78.9 (C_{quat}, 1 C, C(CH₃)₃), 82.8 (C_{quat}, 1 C, C(CH₃)₃), 162.7 (C_{quat}, 1 C, Boc-CO), 164.2 (C_{quat}, 1 C, Boc-CO), 171.8 (C_{quat}, 1 C, C-NH), 176.1 (C_{quat}, 1 C, COO). – **MS** (ES, DCM/MeOH + 10 mmol/l NH₄OAc): *m/z* (%) = 275.2 (32) [MH⁺ - Boc], 319.2 (18) [MH⁺ - C₄H₈], 375.2 (100) [MH⁺]. – **IR** (neat) [cm⁻¹]: $\tilde{\nu}$ = 2975, 2935, 1559, 1541, 1499, 1408, 1366, 1303, 1249, 1148, 1056, 973, 864. – **MF** C₁₅H₂₆N₄O₇. – **MW** 374.39.

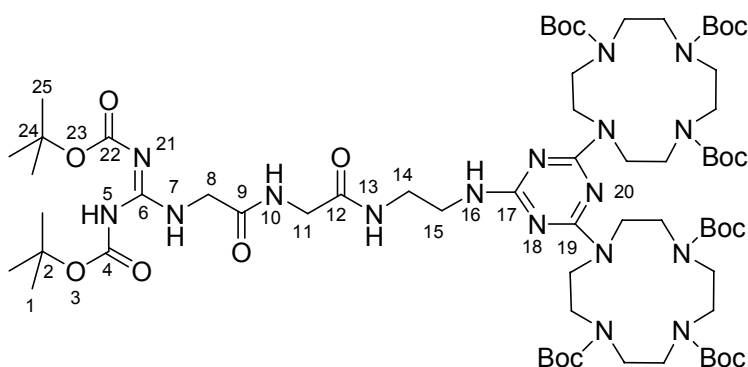
**Compound 69:**

The acid **68** (0.26 g, 0.69 mmol), HOBt (0.14 g, 1.0 mmol) and DIPEA (0.36 ml, 2.0 mmol) were dissolved under nitrogen atmosphere in dry DMF (10 ml). The mixture was cooled to 0 °C in an ice bath and EDC (0.18 ml, 1.0 mmol) was added. Then the amine **52** (0.50 g, 0.46 mmol) was added slowly in portions. The reaction progress was monitored by TLC (EtOAc). After 24 h the solution was added to water and extracted with DCM. The combined organic layers were then washed three times with an aqueous citric acid solution (10 %) and twice with brine. Afterwards the solution was dried over MgSO₄ and concentrated under reduced pressure. The crude product was then purified by flash chromatography on silica gel (EtOAc, R_f = 0.26) to give the product as a colorless solid (0.15 g, 0.11 mmol, 23 %).

MP 162-163 °C. – **¹H-NMR** (300 MHz, CDCl₃): δ = 1.24-1.57 (m, 72 H, 1 + 25 + Cyclen Boc-CH₃), 3.02-3.73 (m, 36 H, 14 + 15 + Cyclen-CH₂), 3.89 (d, ³J_{H,H} = 4.7, 2 H, 8), 4.10 (d, ³J_{H,H} = 4.9, 2 H, 11), 5.00 (s, 1 H, NH), 6.91 (s, 1 H, NH), 7.49 (s, 1 H, NH), 8.87 (s, 1 H, NH), 11.34 (s, 1 H, NH). – **¹³C-NMR** (75 MHz, CDCl₃): δ = 28.0-28.5 (+, 34 C, 1 + 25 + Cyclen Boc-CH₃), 40.5 (-, 1 C, 14), 42.8 (-, 1 C, 15), 44.2 (-, 2 C, 8 + 11), 50.3 (-, 16 C, Cyclen-CH₂), 79.4 (C_{quat}, 1 C, 2), 79.9 (C_{quat}, 6 C, Cyclen Boc-C_{quat}), 83.2 (C_{quat}, 1 C, 24), 152.8 (C_{quat}, 1 C, 4), 155.9 (C_{quat}, 6 C, Cyclen Boc-CO), 156.4 (C_{quat}, 1 C, 22), 163.2 (C_{quat}, 1 C, 6), 168.1-168.5 (C_{quat}, 3 C, 17 + 18), 171.1 (C_{quat}, 2 C, 9 + 12). – **MS** (ES, DCM/MeOH + 10 mmol/l NH₄OAc): *m/z* (%) = 619.2 (67) [M + 2 H⁺ - 2 Boc], 719.3 (26) [M + 2H⁺], 1437.3 (100) [MH⁺]. – **Elemental Analysis**. (%) for C₆₆H₁₁₇N₁₇O₁₈ (1436.74) + 2 H₂O: C 53.82, H 8.28, N 16.17. - found: C 53.69, H 8.31, N 15.61. – **IR** (neat) [cm⁻¹]: $\tilde{\nu}$ = 3318, 3109, 2982, 2952, 1757, 1725, 1637, 1614, 1292, 1138, 1094, 1060, 975, 874, 811. – **MF** C₆₆H₁₁₇N₁₇O₁₈. – **MW** 1436.74.

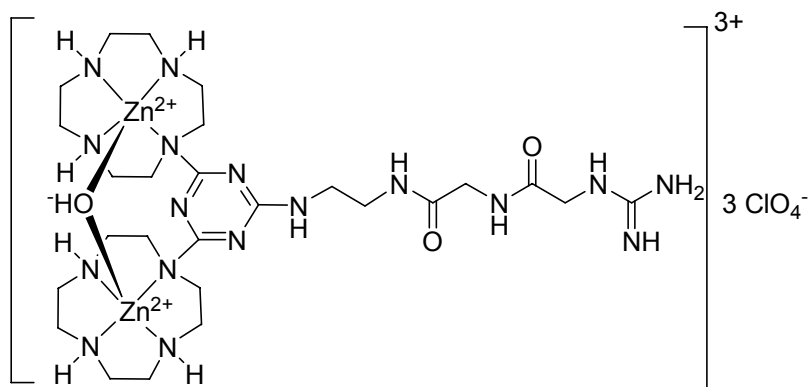
**Complex 70:**

Compound **69** (0.15 g, 0.11 mmol) was dissolved in methanol and cooled to 0 °C in an ice bath. HCl saturated diethyl ether (0.7 ml/mmol Boc-group) was added to the solution. The mixture was allowed to warm to room temperature and was stirred over night. The solvent was evaporated and the crude product was dissolved in water and purified over an ion exchanger column using a strongly basic ion exchange resin (OH⁻-form, loading 0.9 mmol/ml, 4 eq. per protonated nitrogen) to give a colorless solid after lyophilization. Two aqueous solutions, one containing the obtained colorless solid from the column and a second containing Zn(ClO₄)₂ · 6 H₂O (90 mg, 0.24 mmol, 2.2 eq. per deprotected receptor) were prepared. These two solutions were then simultaneously added drop wise to water at 80 °C under vigorous stirring. The resulting mixture was stirred at 90 °C over night. The solution was freeze dried and the product was recrystallized from a water methanol mixture to give the complex as colorless solid in 63 % yield. (75 mg, 0.07 mmol).

MP > 250 °C. – **MS** (ES, H₂O/MeOH + 10 mmol/l NH₄OAc) (K⁴⁺ = C₂₆H₅₃N₁₇O₂Zn₂) : *m/z* (%) = 353.9 (29) [K⁴⁺ + ClO₄⁻ + 2 HClO₄], 392.3 (100) [K⁴⁺ + OH⁻ - H⁺], 413.8 (41) [K⁴⁺ + CH₃COO⁻ - H⁺], 909.3 (8) [K⁴⁺ + OH⁻ + 2 Cl⁻ + CH₃COOH]. – **IR** (neat) [cm⁻¹]: $\tilde{\nu}$ = 3282, 2950, 2896, 2364, 2343, 1652, 1558, 1429, 1347, 1285, 1084, 970, 815, 777. – **MF** [C₂₆H₅₃N₁₇O₂Zn₂]⁴⁺(ClO₄)₃(OH). – **MW** 1081.94.

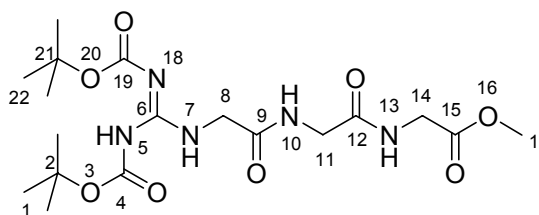
**Compound 90:**

H-Gly-Gly-Gly-OMe · HCl **71** (500 mg, 2.09 mmol) was dissolved in CHCl₃:methanol 5:1 and triethylamine (578 µl, 4.17 mmol) was added. The mixture was stirred for 10 minutes. Then 1,3-bis(Boc)-2-methyl-2-thiopseudourea **63** (727 mg, 2.50 mmol) was added and the mixture was stirred for 24 hours at room temperature. The reaction progress was monitored by TLC. The reaction mixture was uptaken in water and extracted three times with DCM. Afterwards the combined organic layers were dried over MgSO₄ and concentrated under reduced pressure. The crude product was purified by flash-chromatography on silica gel using EtOAc (R_f = 0.20) as eluent. The pure product was obtained as colorless solid in 49 % yield. (460 mg, 1.03 mmol)

MP 117-118 °C. – **¹H-NMR** (300 MHz, CDCl₃): δ = 1.46 (s, 9 H, 1/22), 1.49 (s, 9 H, 1/22), 3.72 (s, 3 H, 17), 3.97-4.06 (m, 4 H, 8 + 11), 4.15-4.24 (m, 2 H, 14), 7.21 (t, ³J_{H,H} = 5.2, 1 H, 10/13), 7.41 (t, ³J_{H,H} = 5.1, 1 H, 10/13), 9.00 (s, 1 H, 5/7), 11.38 (s, 1 H, 5/7). – **¹³C-NMR** (75 MHz, CDCl₃): δ = 28.0 (+, 3 C, 1/22), 28.2 (+, 3 C, 1/22), 41.2 (-, 1 C, 8/11/14), 43.1 (-, 1 C, 8/11/14), 44.5 (-, 1 C, 8/11/14), 52.4 (-, 1 C, 17), 80.1 (C_{quat}, 1 C, 2), 83.8 (C_{quat}, 1 C, 21), 156.2 (C_{quat}, 1 C, 4), 156.2 (C_{quat}, 1 C, 19), 162.5 (C_{quat}, 1 C, 6), 169.0 (C_{quat}, 1 C, 9/12), 169.2 (C_{quat}, 1 C, 9/12), 170.2 (C_{quat}, 1 C, 15). – **MS** (ES, DCM/MeOH + 10 mmol/l NH₄OAc): *m/z* (%) = 390.1 (13) [MH⁺ - C₄H₈], 446.2 (100) [MH⁺]. – **IR** (neat) [cm⁻¹]: $\tilde{\nu}$ = 3334, 3298, 3276, 2978, 2938, 1731, 1641, 1612, 1547, 1368, 1304, 1224, 1144, 1107, 1058, 1032, 977. – **MF** C₁₈H₃₁N₅O₈. – **MW** 445.47.

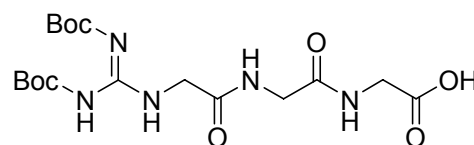
**Compound 72:**

Compound **90** (460 mg, 1.03 mmol) was dissolved in a mixture of water and THF 1:4. LiOH (30 mg, 1.24 mmol) was added and the mixture was stirred at room temperature over night. The solution was acidified with 5 % aqueous KHSO₄ solution and was extracted with DCM. The combined organic layers were dried over MgSO₄ and concentrated under reduced pressure to give the product as colorless solid in 79 % yield. (350 mg, 0.81 mmol)

MP 87-88 °C. – **¹H-NMR** (300 MHz, CDCl₃): δ = 1.44 (s, 9 H, Boc-CH₃), 1.48 (s, 9 H, Boc-CH₃), 3.92 (d, ³J_{H,H} = 4.9, 2 H, CH₂), 4.05 (d, ³J_{H,H} = 4.7, 2 H, CH₂), 4.18 (s, 2 H, CH₂), 7.67 (t, ³J_{H,H} = 5.0, 1 H, NH), 8.02 (t, ³J_{H,H} = 5.2, 1 H, NH), 9.28 (bs, 1 H, NH), 11.39 (bs, 1 H, NH). – **¹³C-NMR** (75 MHz, CDCl₃): δ = 28.0 (+, 6 C, Boc-CH₃), 42.0 (-, 1 C, CH₂), 42.8 (-, 1 C, CH₂), 44.0 (-, 1 C, CH₂), 80.6 (C_{quat}, 1 C, OC(CH₃)₃), 83.9 (C_{quat}, 1 C, OC(CH₃)₃), 152.6 (C_{quat}, 1 C, Boc-CO), 155.7 (C_{quat}, 1 C, Boc-CO), 161.7 (C_{quat}, 1 C, Guanidine), 168.8 (C_{quat}, 1 C, CONH), 170.5 (C_{quat}, 1 C, CONH), 172.5 (C_{quat}, 1 C, COOH). – **MS** (ES, DCM/MeOH + 10 mmol/l NH₄OAc): *m/z* (%) = 432.1 (100) [MH⁺], 863.6 (9) [2 M + H⁺]. – **IR** (neat) [cm⁻¹]: $\tilde{\nu}$ = 3135, 2962, 1759, 1671, 1593, 1498, 1454, 1411, 1339, 1272, 1244, 1216, 1157, 1062, 981, 915, 795, 732, 697. – **MF** C₁₇H₂₉N₅O₈. – **MW** 431.44.

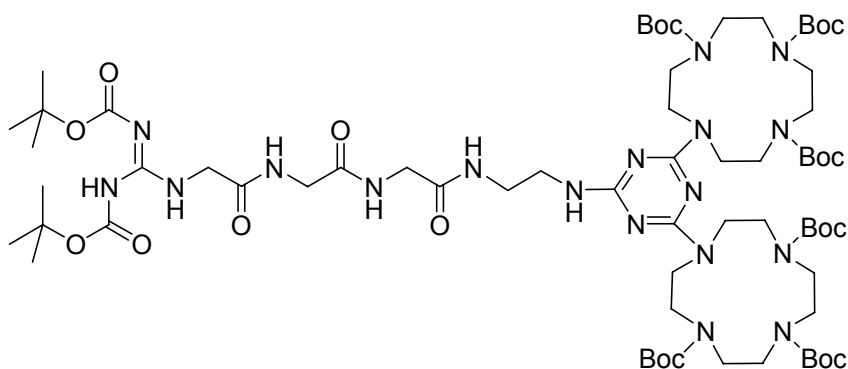
**Compound 73:**

The acid **72** (350 mg, 0.81 mmol), HOBt (219 mg, 1.62 mmol) and DIPEA (417 μ l, 2.43 mmol) were dissolved under nitrogen atmosphere in dry DMF (14 ml). The mixture was cooled to 0 °C in an ice bath and EDC (287 μ l, 1.62 mmol) was added. Then the amine **52** (1.05 g, 0.97 mmol) was added slowly in portions. The reaction progress was monitored by TLC (EtOAc). After 24 h the solution was added to water and extracted with DCM. The combined organic layers were then washed three times with an aqueous citric acid solution (10 %) and twice with brine. Afterwards the solution was dried over MgSO_4 and concentrated under reduced pressure. The crude product was purified by flash-chromatography on silica gel (EtOAc, R_f = 0.26) to give the product as a colorless solid (730 mg, 0.49 mmol, 60 %).

MP 174 °C. – **$^1\text{H-NMR}$** (300 MHz, CDCl_3): δ = 1.22-1.53 (m, 72 H, Boc- CH_3), 3.04-3.75 (m, 36 H, CH_2 + Cyclen- CH_2), 3.84-3.93 (m, 4 H, CH_2), 4.11 (d, $^3J_{\text{H,H}}$ = 5.1, 2 H, CH_2), 8.92 (s, 1H, NH), 11.32 (s, 1 H, NH). – **$^{13}\text{C-NMR}$** (75 MHz, CDCl_3): δ = 28.0-28.5 (+, 34 C, Boc- CH_3), 40.3 (-, 1 C, CH_2), 42.9 (-, 1 C, CH_2), 44.4 (-, 2 C, CH_2), 50.3 (-, 16 C, Cyclen- CH_2), 79.7 (C_{quat} , 1 C, Boc- C_{quat}), 79.9 (C_{quat} , 6 C, Cyclen Boc- C_{quat}), 83.4 (C_{quat} , 1 C, Boc- C_{quat}), 152.7 (C_{quat} , 1 C, Boc-CO), 156.3 (C_{quat} , 6 C, Cyclen Boc-CO), 156.4 (C_{quat} , 1 C, Boc-CO), 162.6 (C_{quat} , 3 C), 163.0 (C_{quat} , 1 C), 165.9 (C_{quat} , 2 C, CO), 168.9 (C_{quat} , 1 C, CO). – **MS** (ESI, MeCN/water + 0.0059% TFA): m/z (%) = 747.7 (100) [$\text{M} + 2 \text{H}^+$], 1494.5 (100) [MH^+]. – **IR** (neat) [cm^{-1}]: $\tilde{\nu}$ = 2974, 2927, 2869, 1686, 1536, 1504, 1408, 1364, 1307, 1246, 1152, 1105, 1058, 1029, 812, 777. – **MF** $\text{C}_{68}\text{H}_{120}\text{N}_{18}\text{O}_{19}$. – **MW** 1493.79.

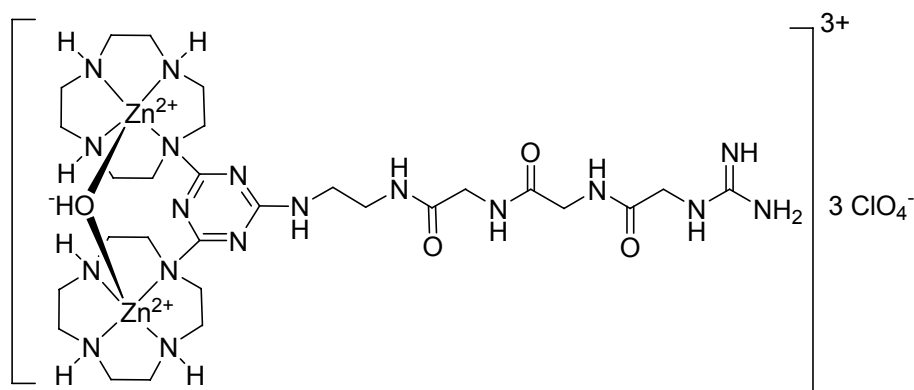

Complex 74:

Compound **73** (634 mg, 0.49 mmol) was dissolved in methanol and cooled to 0 °C in an ice bath. To the solution HCl saturated diethyl ether (0.7 ml/mmol Boc-group) was added. The mixture was allowed to warm to room temperature and stirred over night. The solvent was evaporated and the crude product was dissolved in water and purified over an ion exchanger column using a strongly basic ion exchange resin (OH⁻-form, loading 0.9 mmol/ml, 4 eq. per protonated nitrogen) to give a colorless solid after freeze drying. Two aqueous solutions one containing the obtained colorless solid from the column and a second containing Zn(ClO₄)₂ · 6 H₂O (90 mg, 0.24 mmol, 2.2 eq. per deprotected receptor) were prepared. These two solutions were then simultaneously added drop wise to 80 °C hot water under vigorous stirring. The resulting mixture was stirred at 90 °C over night. The solution was freeze dried and the product was recrystallized from a water methanol mixture to give the complex as colorless solid in 20 % yield. (109 mg, 0.10 mmol).

MP > 180 °C. – **MS** (ES, H₂O/MeOH + 10 mmol/l NH₄OAc) (K⁴⁺ = C₂₈H₅₇N₁₈O₃Zn₂) : *m/z* (%) = 419.8 (100) [K⁴⁺ + OH⁻ - H⁺]. – **IR** (neat) [cm⁻¹]: $\tilde{\nu}$ = 2973, 2929, 2870, 1684, 1535, 1501, 14011, 1364, 1308, 1247, 1153, 1104, 1061, 1030, 812, 776. **MF** [C₂₈H₅₇N₁₈O₃Zn₂]⁴⁺(ClO₄)₃(OH). – **MW** 1140.00.

B. Synthesis and Use of Tetrahydrofuran Amino Acids

1. Introduction

1.1. Proteins

Proteins are omnipresent in the living world. The structure, function and metabolism of all cells and tissues rely on the presence of specific proteins. They are in some way the carrier of the live functions and can be found likewise in animal, plants and micro organism,

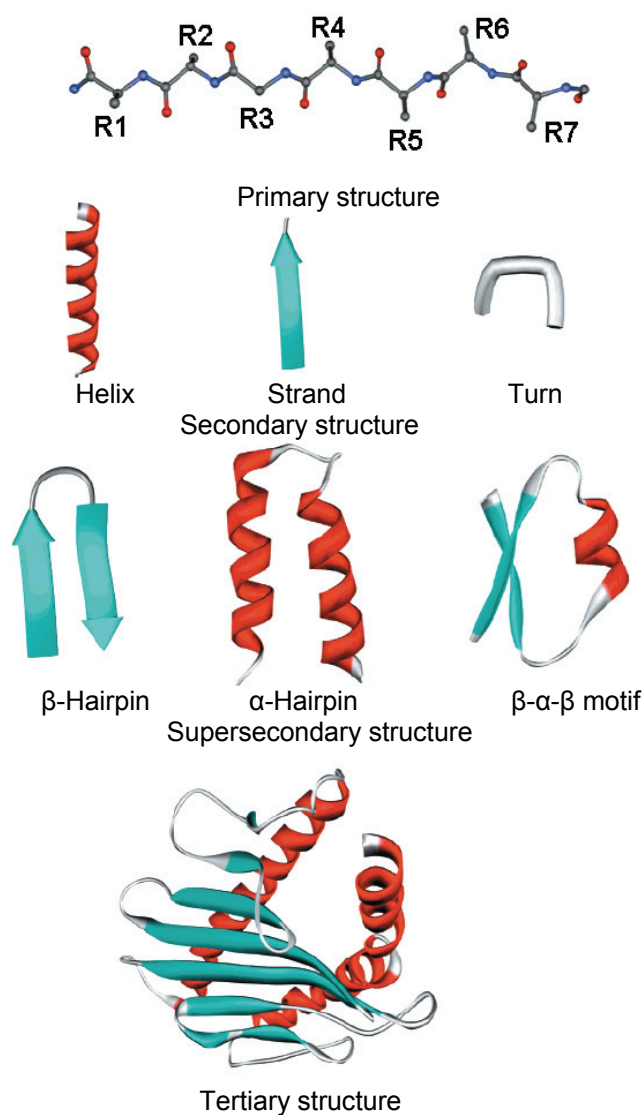

Figure 51: Organization of the protein structures in different levels. (adapted from literature¹²³)

for example in muscles (actin, myoglobin), in the blood (hemoglobin), in connective tissues, sinews and ligaments (collagen, elastin) to mention only a very few. But not only is their occurrence manifold, their functions are also very diverse for example in the immune response, as hormone- or neurotransmitter-receptors but also as enzymes and regulators. These functions of proteins are particularly dependent on the 3D-structure of the amino acid backbone. The construction of such complex protein folds relies on the precise conversion of one or more linear polypeptide chains into a 3D-structure.¹²²

Until now it is not completely understood how the amino acid sequence (primary structure) is linked to the tertiary or quaternary structure of proteins. When having a closer look into these higher folds a limited number of secondary structural elements can be found as there are helices, turns and strands which are connected via loosely structured turns (see Figure 51).¹²³ The folding of proteins consisting of different secondary structures arises from tertiary interactions between residues which are distant in the sequence. Main forces for the stabilization of the overall protein structure are hydrophobic interactions. The protein folds in such a way that the hydrophobic side chains of amino acids like valine or isoleucine can aggregate in the center of the protein while polar side chains point towards the surrounding water. Other important forces are electrostatic interactions like van-der-Waals-forces, H-bonds or salt bridges. In addition, the protein structure can be stabilized by covalent disulfidbridges formed between two cystein residues or by metal-ions like Zn(II) which can also serve as a bridging element in the interior of proteins.¹²⁴ In the last years increasing effort was put into the development of a deeper understanding of the protein structure itself but also into the relationship of amino acid sequence, 3D-structure and function of proteins.¹²⁵

1.1.1. Protein-Protein Interactions

One way how nature controls protein function within living cells is by regulating protein-protein interactions. These interactions exist at nearly every level of cellular function which means they are of key importance for virtually every process in a living organism. To mention only a few, there are the signal transduction pathway important for the transportation of information through the organism and from the exterior of cells to the inside, the transport machinery across the biological membranes, the regulation of gene expression or the muscle contraction. Protein-protein interactions play a decisive role in biological processes and their disregulation leads to diseases like Creutzfeld-Jacob, Alzheimer, cancer or HIV.¹²⁶

1.1.2. Protein Design

In the same way that the structure analysis and the development of a deeper understanding of protein-protein interactions are fields of active research, the *de novo* design of natural occurring or novel peptides is also being investigated. Synthesis methods like the solid phase peptide synthesis (SPPS) developed by Bruce Merrifield made it possible to synthesize polypeptides with almost fifty amino acids in length in quantities making them suitable for pharmacological and clinical assays as well as for use as drugs or in diagnostics.¹²⁷ As a result, different new peptide-based drugs are nowadays available for the treatment of prostate and breast cancer, as HIV protease inhibitors or as ACE inhibitors to treat hypertension and congestive heart failures, to mention only a few.¹²⁸

Despite the fact that such polypeptides based on natural amino acids are widely used as therapeutic agents, there are also problems connected with the use of natural peptides as drugs. The problems arise mainly from the low stability against proteolysis resulting in a short duration of activity *in vivo* and a low bioavailability, thus limiting the use of peptides as drugs. They also often show a decreased activity in comparison to the protein from which they are derived. A major difficulty in these studies is the conformational flexibility of most peptides and the high dependence of their conformations on the surrounding environment which often leads to a conformational equilibrium.¹²⁹

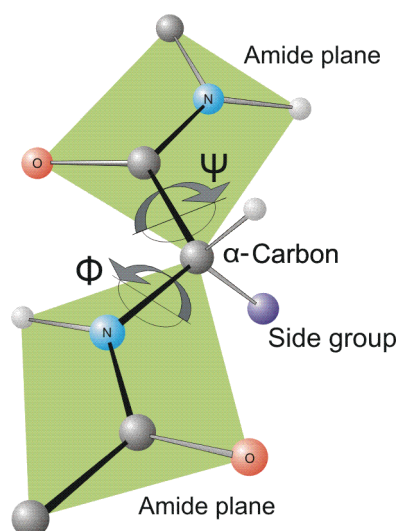

Figure 52: The torsional degrees of freedom in a peptide bond. (adapted from literature^{125b})

The high flexibility of natural polypeptides originates from the multiple conformations which are energetically possible at each residue of the incorporated amino acids. Every amino acid has two degrees of conformational freedom, N- C^α (ϕ) and C^α -CO (ψ) resulting

in approximately $9 (3^2)$ stable local conformations. For a small peptide with only 40 amino acids in length the number of possible conformations which need to be considered escalates to nearly 10^{40} . Pioneering work by *Ramachandran et al.* resulted in the so called Ramachandran plots which restrict the allowed values for the torsion angles Φ and Ψ and with that the conformational space accessible to the amino acids to about one-third of the total structural space. Nevertheless the remaining degrees of freedom still make a prediction of the structure extremely difficult. This extraordinary high flexibility of natural amino acids leads to the fact that short polypeptides consisting of the 20 proteinogenic amino acids rarely form any stable 3D-structures in solution.¹³⁰

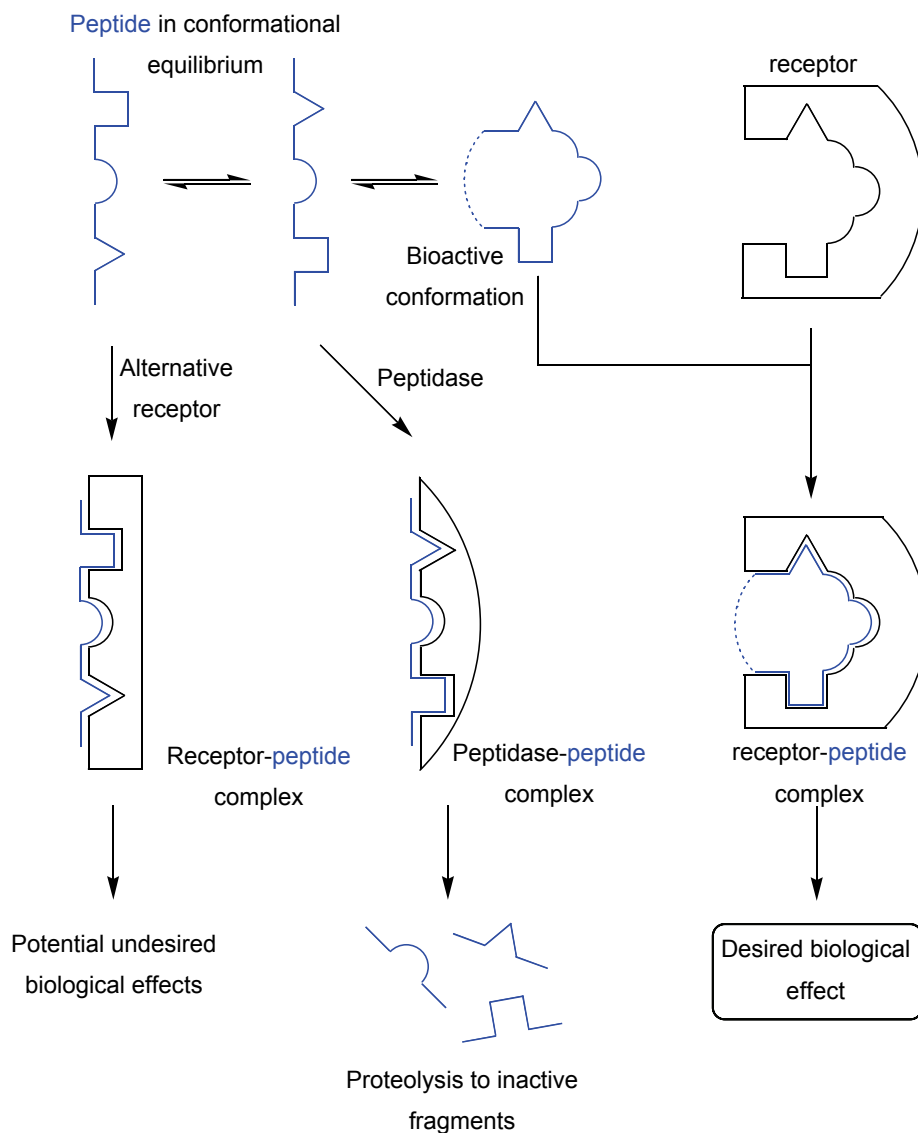

Figure 53: Peptides can exist in different conformations. By introducing conformational constraints into the peptide backbone (blue dashed line) the equilibrium can be shifted towards the conformation which leads to the desired biological effect. In addition, it might be possible to suppress undesired side effects or proteolysis. (adapted from literature¹³¹)

There are only few examples reported in literature where short to medium sized peptides (< 30-50 amino acids) were able to form stable structures. In most cases they exist unordered in aqueous solution in numerous of conformations which are in a dynamic equilibrium with each other. Additionally, the number of structures which are accessible is very limited because of the need to use amino acids which have a strong structure inducing effect like for example helix-inducing amino acids like leucine, glutamic acid or lysine. In addition, it is questionable whether the solid state conformations determined by X-ray analysis are identical to those occurring in solution or during the interactions of proteins with each other.¹³²

1.2. Peptidomimetics

One way to overcome these disadvantages of natural short polypeptides is the use of so called peptidomimetics. These are small protein-like molecules designed to mimic natural peptides or proteins. These mimetics should have the ability to bind to their natural targets in the same way as the natural peptide sequences do from which their structure was derived. They should produce the same biological effects. It is possible to design these molecules in such a way that they show the same biological effects as their peptide role models but with enhanced properties like a higher proteolytic stability, higher bioavailability and also often with improved selectivity or potency. This makes them interesting targets for the discovery of new drug candidates.^{133,134,135,136}

For the development of potent peptidomimetics it is necessary to understand the forces that lead to protein-protein interactions with nanomolar or often even higher affinities. These strong interactions between peptides and their corresponding proteins are mainly based on side chain interactions indicating that the peptide backbone itself is not an absolute requirement for high affinities. This allows chemists to design peptidomimetics basically from any scaffold known in chemistry by replacing the amide backbone partially or completely by other structures. Most important is that the backbone is able to place the amino acid side chains in a defined 3D-position to allow interactions with the target protein. Therefore it is necessary to develop an idea of the required structure of the peptidomimetic to show a high activity against its biological target. This can be achieved by conducting structure-activity relationship (SAR) investigations. By this method, the shortest active sequence in the natural protein-protein interaction can be identified. To do so, shorter analogues of the natural sequence are synthesized and tested against the target protein to identify the minimum sequence necessary for biological activity. The most significant parameters such as stereochemistry, charge and hydrophobicity can be examined by systematic exchange of single amino acids. As a result, the key residues which are essential for the biological activity can be identified. As next step the 3D arrangement of these key residues needs to be analyzed by the use of compounds with rigid conformations to identify the most active structure.^{132, 137} When a clear model of the moieties necessary for the interaction and their location in the 3D space has been gathered, these elements can then be reassembled by the use of peptidic or non-peptidic structures to form a peptidomimetic with the same biological activity as the natural role model which it should replace.¹³⁸ This is a rather expensive and time-consuming method but the use of new techniques that allow the fast synthesis and analysis of receptor binding of a great variety of peptides allows the whole process to become more efficient.^{139, 140}

All in all, the development of peptidomimetics is based mainly on the knowledge of the electronic, conformational and topochemical properties of the native peptide its target. Two structural factors are especially important for the synthesis peptidomimetics with high biological activity. Firstly the mimetic has to have a convenient fit to the binding site and secondly the functional groups, polar and hydrophobic regions of the mimetic need to be placed in defined positions to allow the useful interactions to take place.¹⁴¹

As previously mentioned the major problem in this area of research is the conformational flexibility of most natural peptides and the high dependence of their conformation on the environment. One very successful approach to overcome these drawbacks is the introduction of conformational constraints into the peptide sequence. This can be done for example by cyclisation (main chain to main chain; side chain to main chain or side chain to side chain) or by the incorporation of amino acids which can only adopt a very limited number of different conformations.¹⁴²

In the following, a summary of approaches leading to peptidomimetics is given. Different approaches to the design of peptidomimetics will be presented together with a few select examples. However, due to the large number of different unnatural amino acids and peptidomimetics the overview can not be comprehensive. Therefore the following selection should be seen as an overview illustrating the importance and diversity of the design and synthesis of peptidomimetics.

1.2.1. Amino Acid Modifications

One way which leads to conformationally restricted and metabolically stable peptidomimetics is the use of unnatural amino acids. In principal, two different starting points exist for the modification of peptides at the amino acid level. One is the amino acid side chain which can be rigidified for example by the use of sterically demanding groups, the other is the backbone of the peptide.

1.2.1.1. Side Chain Modification

Side chains of natural amino acids are of great importance for the activity of proteins due to their various functional groups which allow them to interact with other peptides or proteins. The problem hereby is their quite high conformational flexibility with energy barriers of rotation around their torsion angles χ^1 ($C^\alpha-C^\beta$ bond), χ^2 ($C^\beta-C^\gamma$ bond), etc. of normally less than 8 kcal/mol. Therefore they can rotate freely at physiological temperatures, with the exception the proline which is restricted due to the five-membered ring system.¹⁴³ In order to derive more information about the interactions of peptides with

proteins, nucleic acids, other peptides, lipids and sugars in biological systems, side chain conformational restriction can provide a versatile tool for design of peptidomimetics.¹⁴⁴

β -Substitution

β -Substituted analogues of the naturally occurring amino acids are one example for rigidification in the side chain. Three of the natural 20 amino acids also show β -disubstitutions. These are valine **91** which has a two β -methyl substituents, isoleucine **92** which has a β -methyl and a β -ethyl substitution and threonine **93** which has a β -methyl and a β -hydroxy substitution. Both the isoleucine **92** and the threonine **93** have a β -chiral center. Various analogues of natural amino acids alkylated at the β -carbon can be found in literature. For example, the introduction of three methylgroups at the 2'-, 6'- and β -position of natural tyrosine hinders the free rotation around the C ^{β} -C ^{γ} bond and by that might sometimes favor the formation of biologically active conformations (**94**).¹⁴⁵ Introduction of a methyl group into the side chains of phenylalanine or tryptophan leads to the compounds β -MePhe **95** and β -MeTrp **96**. Replacement of the natural amino acids Phe or Trp by their rigidified analogues **95** in the former and **96** in the latter case often results in a in comparison higher activity and an increased biological stability of the modified peptides.¹⁴⁶ For example, the activity of short peptides which are active at the δ -opioid receptor was successfully altered by exchanging phenylalanine by its β -methylated analogue **95**.¹⁴⁷

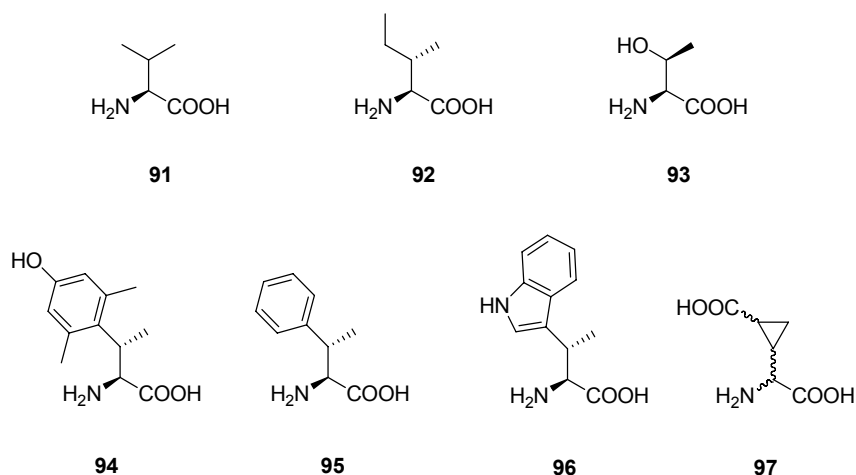

Figure 54: The three β -methylated natural amino acids valine **91**, isoleucine **92** and threonine **93** and some selected examples of unnatural β -methylated amino acids **94-97**.

Another interesting example is the 2-(carboxycyclopropyl)-glycine (CCG) **97**. A library containing all possible diastereomers of compound **97** was used to investigate neuroreceptors activated by *L*-glutamic acid. Several types of such receptors are known until now and it has been suggested that *L*-glutamic acid interacts with different receptors

adopting different conformations. This hypothesis was strongly supported by the findings resulting from the use of the CCG diastereomers.¹⁴⁸

Besides β -disubstituted amino acids numerous other side chain modified amino acids were developed, for example the 2-naphthylalanine **98**.¹⁴⁹ Gonadotropin-releasing hormone (GnRH) antagonists containing this compound in addition to other unnatural amino acids, show high affinity to the receptor.¹⁵⁰

**98**

Figure 55: 2-Naphthylalanine **98**, a building block for novel GnRH antagonists.

Proline Analogues

A further, thoroughly investigated group of side chain modified amino acids are analogues of the natural proline. Proline has a special place among the proteinogenic amino acids because of its secondary structure inducing and stabilizing properties and hence its influence on the biological behavior of peptides.¹⁵¹ This is due to the cyclic structure of proline which restricts the conformational space of the peptide chain drastically.¹⁵²

**99****100****101****102**

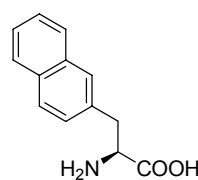
Figure 56: L-Proline **99** and some natural derivatives **100-102**.

Besides proline itself, numerous derivatives were found in proteins as results of posttranslational modifications. *cis*-4-Methyl-L-proline **100** was discovered in hydrolysates of different leucinostatine.¹⁵³ These are peptide antibiotics which were isolated from several *Paecilomyces* strains. These leucinostatines have antitumor activity as well as a wide antimicrobial spectrum against fungi, yeast and Grampositive bacteria.¹⁵⁴ *Trans*-4-hydroxy-L-proline **101** was first isolated from hydrolysates of Mediterranean sponge and later found in several other organisms.¹⁵⁵ The free amino acid **101** can also be found in human urine as a result of collagen metabolism. Also amino side chain modified proline derivatives like the *cis*-3-amino-L-proline **102** can be found in nature.¹⁵⁶ Additionally to the naturally occurring proline analogues countless proline derivatives were synthesized by

the introduction of alkyl chains or aromatic groups in the 3-, 4- and 5- position of the ring. Derivatives with additional heteroatoms and halogenated prolines were also synthesized and extensively studied.¹⁵⁷

1.2.1.2. Backbone Modification

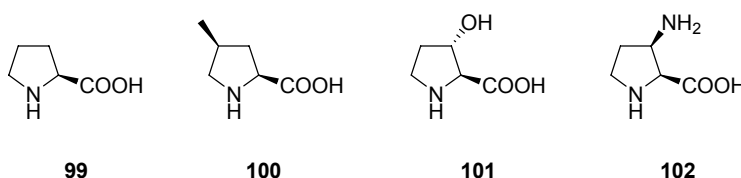
Apart from the side chains, the backbone of a peptide can also be modified in various ways by isosteric or isoelectronic exchange of units in the peptide or by the introduction of additional fragments.¹⁵⁸ Figure 57 summarizes the most important ways to modify the backbone of peptides at different positions.

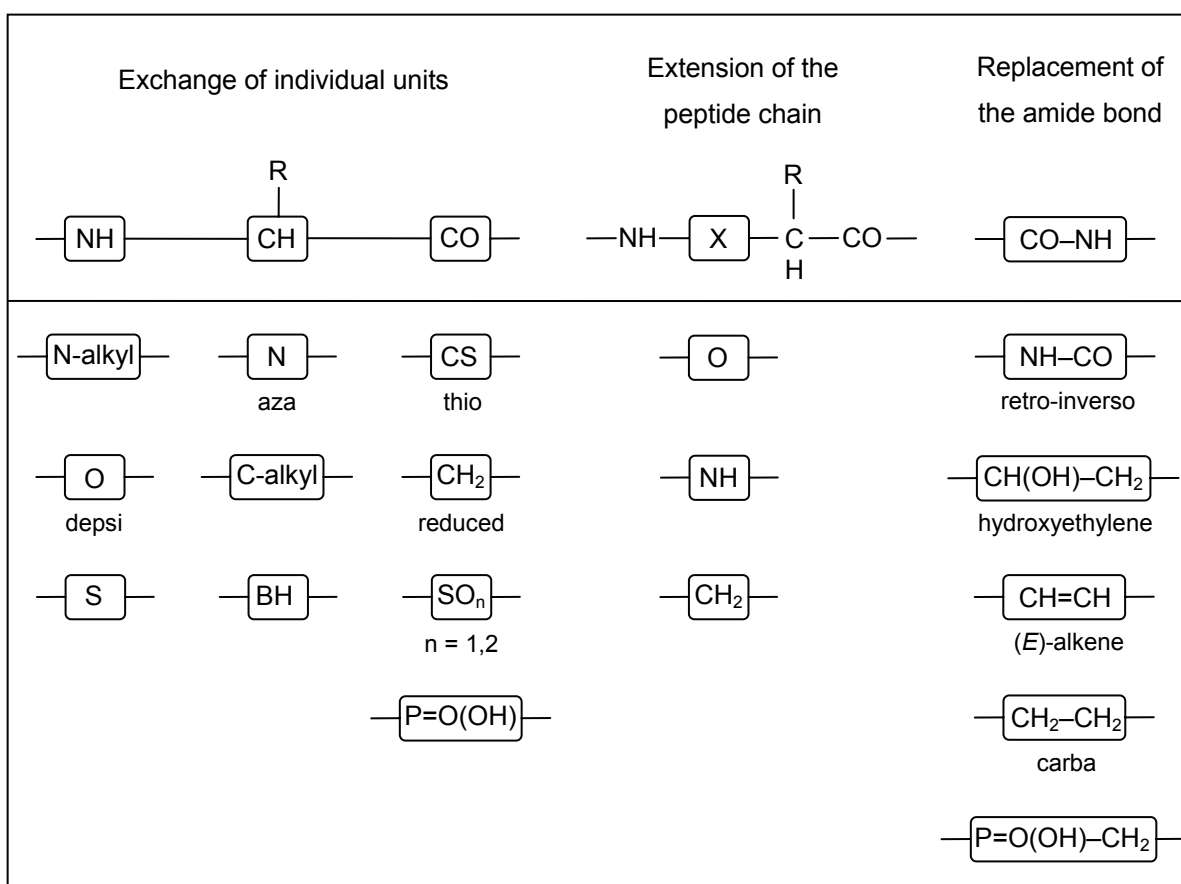

Figure 57: Some of the more common modifications to the peptide backbone. (adapted from literature¹⁵⁹)

Three main groups of modifications are known, with the first being the exchange of individual groups like, the replacement of the α -CH group by nitrogen to form azapeptides, the change from amide to ester bond to get depsipeptides and exchange of the carbonyl function by a CH_2 -group. The second possibility is the extension of the backbone for example by one or two CH_2 -groups resulting in polypeptides built from β -amino acids in the former and γ -amino acids in the latter case. A third widely used technique is the amide

bond inversion, yielding a retro-inverso peptidomimetic. Carba-, alkene- or hydroxyethylene- groups are also used in exchange for the amide bond. Most of these modifications do not lead to a higher restriction of the global conformations, but they have influence on the secondary structure due to the altered intramolecular interactions like different hydrogen bonding. Additionally, the length of the backbone can be different and a higher proteolytic stability occurs in most cases.

Azapeptides

Interesting and synthetically easy to approach are the so called azapeptides in which the α -CH group of the backbone was replaced isoelectronically by a nitrogen atom while the side chains remain untouched. The synthesis of azapeptides from substituted hydrazines or hydrazides can be carried out very easily.¹⁶⁰ When incorporating azaamino acid esters like compound **103** into a peptide chain azapeptides are formed which can be therapeutically relevant inhibitors of serine and cysteine proteases.¹⁶¹ The same is true for the aza analogue **104** including an amino acid chloromethyl ketone. Both compounds **103** and **104** can be easily prepared by the acylation of hydrazines.¹⁶²

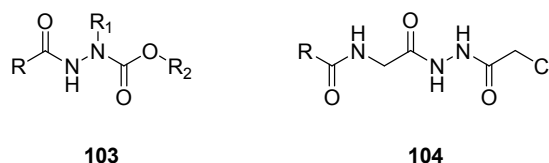

Figure 58: Peptides containing aza amino acids. R = peptide chain; R₁ = H, alkyl, benzyl; R₂ = alkyl, aryl.

Retro-inverso Peptides

Another approach to peptidomimetics are retro-inverso modifications.¹⁶³ These peptidomimetics can be synthesized in the same way as normal peptides just by exchanging the natural *L*-amino acids by *D*-amino acids and simultaneously reversing the sequence from *N*- to *C*-terminus. As shown in Figure 59 the side chain topologies of the natural peptide and the peptidomimetic are the same. Of course, the retro-inverso modification does not lead to a more highly constrained polypeptide. The major advantage over their natural models lies in the higher *in vivo* stability as they are no substrates for proteases any more. One disadvantage of these peptidomimetics is that with the inversion of their sequence the termini are also exchanged. This means that the positive charge located at the *N*-terminus of the natural sequence is replaced by a negative one in the peptidomimetic. The same is true for the *C*-terminus where the negative charge is

replaced by a positive one. To avoid this, one can introduce modified termini or the retro-inverso structures can be incorporated into larger peptides.

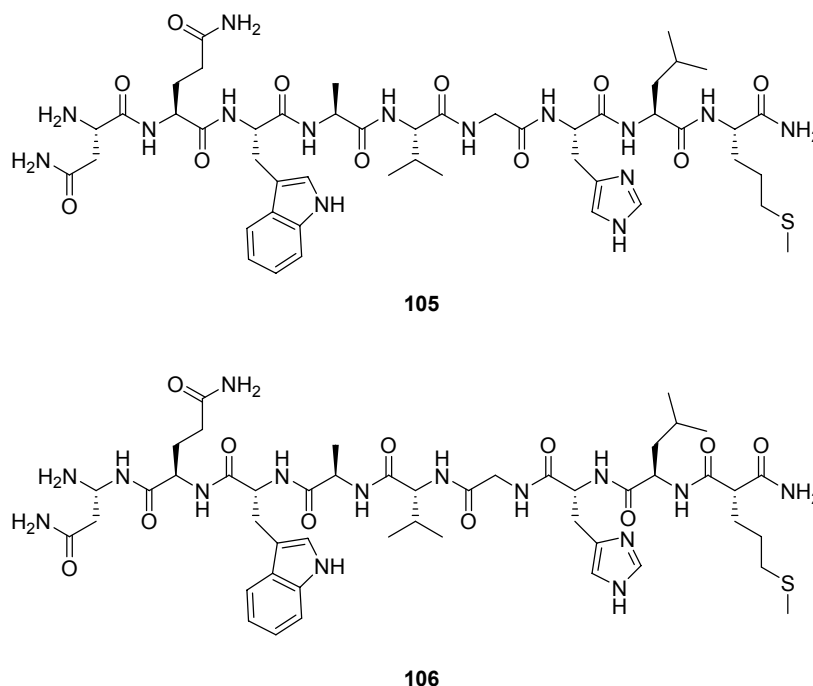

Figure 59: A natural peptide sequence **105** (top) and the retro-inverso analogue **106** (bottom).

The nonapeptide **105** is an active agonist for bombesin while in contrast the retro-inverso analogue **106** shows no activity at all.¹⁶⁴ Unfortunately only a limited number of retro-inverso derivatives show a to their native sequences comparable activity which strongly indicates that the backbone although not always directly involved often has a large impact on the protein-protein binding.¹⁶⁵

***N*-Alkylated Peptides**

N-alkylation is an important modification of the peptide bond. The *N*-methylation is widely used by scientists but also occurs in the sequences of natural peptides from different sources. Some of these compounds show high biological activity as antibiotics (e.g. monamycins,¹⁶⁶ echinomycin¹⁶⁷), insecticides,¹⁶⁸ antitumor agents (e.g. bouvardin¹⁶⁹) and antiinflammatory peptides (e. g. cyclomarins¹⁷⁰).¹⁷¹ Numerous peptides which show biological activity were modified by the use of *N*-methyl amino acids (NMAs), resulting in analogues with improved pharmacological properties such as metabolic stability, selectivity, enhanced potency and bioavailability.^{172, 173}

The structural effects of *N*-alkylation have been intensively examined in *N*-methylated analogues of biologically relevant peptides. They normally show an increased proteolytic stability, increased membrane permeability (lipophilicity) and altered conformational

preferences of the amide bond properties.¹⁷⁴ These effects result from the different property changes in the peptide going along with the introduction of *N*-methylation. Firstly, there are steric constraints introduced by the *N*-alkyl group,¹⁷⁵ which have an effect not only on the conformational freedom of the peptide backbone but also on the side chain of the neighboring amino acid.¹⁷⁶ Secondly, the number of inter- and intramolecular hydrogen bonds decreases due to the removal of the backbone NH-groups. And thirdly, they show an increased basicity and decreased polarity of the attached carbonyl group.

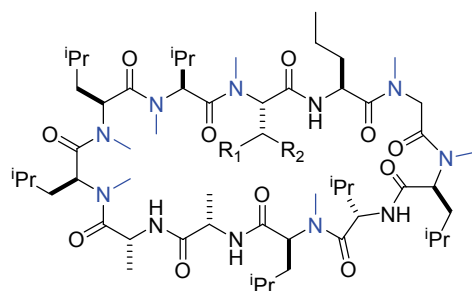

107

cyclosporin A (CsA): $R_1 = \text{OH}$; $R_2 = \text{CH}(\text{CH}_3)\text{CH}_2\text{CH}=\text{CHCH}_3$ cyclosporin O (CsO): $R_1 = R_2 = \text{CH}_3$

Figure 60: Structures of Cyclosporin A and O; *N*-methylation is indicated in blue.

In natural proteins only the *N*-methylation and *N*-benzylation were observed until now. One of the most outstanding examples of a *N*-methylated peptide is the cyclic undecapeptide cyclosporine A (Figure 60) with seven *N*-methylated amino acids. It was first isolated from *Trichoderma polysporum* and is a member of the cyclic peptide immunosuppressants which in addition shows improved pharmacological properties and a low toxicity. These properties make it one of the most successful drugs (Sandimmun) used after organ transplantations.¹⁷⁷ Although the total synthesis of cyclosporine A was already accomplished by *Wenger et al.* in 1984,¹⁷⁸ the interest in this group of immunosuppressants has not decreased as the example of cyclosporine O shows which was synthesized on solid support by *Thern et al.* in 2002.¹⁷⁹

N-Alkylation is also a powerful and often used tool for the study of structure-activity relationships. Biologically active peptides, often have insufficient pharmacological properties due to the low *in vivo* stability and their high flexibility. These properties disfavor their use as pharmacophores and in clinical studies. *N*-alkylated amino acids which are introduced into peptide chains can help to overcome the shortfalls of their natural models due to the above mentioned effects.

Another important advantage of NMAs is that many of them are commercially available in protected form allowing the direct use of these building blocks in solid phase peptide

synthesis while several others can be easily synthesized.¹⁸⁰ By this method, libraries of natural product analogues can be produced in a very short amount of time. By successively alkylating each backbone NH and evaluating the biological activity of the produced compounds, the most active peptide can be found and with that the residues important for the interaction can be identified. The method is known as *N*-alkyl-scan. This concept was invented by *Sugano et al.* who synthesized a series of analogues of the peptide H-Lys-Phe-Ile-Gly-Leu-Met-NH₂ in which each peptide bond was *N*-methylated one after the other. Screening of this series of five peptides on the depressor activity of rabbit blood revealed that the modification of Ile and Met lead to inactive compounds while the exchange of Phe and Leu showed no effect. Using this information the peptidomimetic H-Lys-(Me)Phe-Ile-Gly-(Me)Leu-Met-NH₂ was prepared. This compound showed full depressor activity while having a higher resistance against digestion.¹⁸¹

Peptoids

One very interesting subgroup of the *N*-alkylated amino acids are the so called peptoids which contain *N*-alkylated glycines linked in a peptide-like manner. The α -CH groups have been replaced by nitrogens (like in aza peptides) and conversely, the NH-groups by CH₂-groups (similar to carba peptides). As a result, the side chains and the carbonyl groups remain at their places, while the backbone CH- and NH-groups change their places.

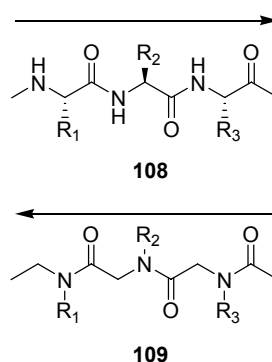

Figure 61: Comparison of a natural peptide sequence **108** with a topologically similar peptoid sequence **109**.

Figure 61 illustrates that the sequence of peptoids are opposite to the ones of native peptides, which is similar to the retro-inverso peptidomimetics. Another difference to natural sequences is the loss of stereoinformation as the chiral α -carbon of natural amino acids is replaced by a CH₂-group and the side chains are now attached to nitrogen atoms. Peptoid analogues of most natural amino acids have been prepared and they can also be used in solid phase synthesis.¹⁸² Analysis of peptoids has shown that they are stable to proteolytic enzymes and that they have an even higher conformational flexibility compared

to natural peptides. Further studies have shown that peptoids like Ac-Nhtrp-Narg-Nhtyr-NH₂¹⁸³ can be as active as their natural models (Ac-Trp-Arg-Tyr-OMe), in this case as an α -amylase inhibitor. An interesting aspect of this system is that the inverse peptoid sequence Ac-Nhtyr-Narg-Nhtrp-NH₂ shows an even higher activity than the nature like forward sequence.¹⁵⁹

C ^{α} -Tetrasubstituted α -Amino Acids

Other backbone modifications which have been extensively investigated in the last years are the so called C ^{α} -tetrasubstituted α -amino acids (or C ^{α,α} -disubstituted glycines). This kind of amino acid also occurs in natural sequences, for example in proteins in fungi. 50 years ago the first α -aminobutyric acid (Aib, **110**) containing peptide sequence from a fungal source was found.¹⁸⁴ Because of their unique bioactivities and conformations, a fast growing group of peptide antibiotics, the so-called peptaibiotics, has regained particular interest.¹⁸⁵ As the majority of Aib- or isovaline- (Iva, **111**) containing peptides carry a C-terminal residue representing a 2-amino alcohol, they are referred to as peptaibols.¹⁸⁶

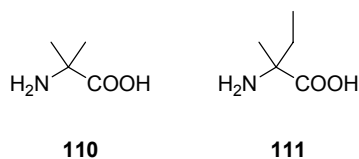

Figure 62: C ^{α} -tetrasubstituted α -amino acids: α -aminobutyric acid (Aib, **110**) and isovaline (Iva, **111**) are found in natural products.

One interesting peptaibol example is the Alamethicin. It is an antimicrobial membrane-active peptide which is proposed as an alternative for the treatment of infections since the resistance to normal antibiotics becomes an increasing medical problem.¹⁸⁷

Besides the natural occurring peptidomimetics based on C ^{α} -tetrasubstituted α -amino acids, a rapidly increasing number of unnatural amino acids are developed by scientists and used for the synthesis of peptidomimetics.¹⁸⁸ Exchanging one glycine in the Leu-Enk sequence **112**, which is an enkephalin (enkephalin is a pentapeptide involved in regulating pain and nociception in the body) by C ^{α} -tetrasubstituted α -amino acids leads to the peptides **113-115**. All of these analogues possess a β -turn like structure in solution induced by the unnatural amino acid and show high activity with IC₅₀-values between 0.01 nM and 0.4 nM.¹⁸⁹

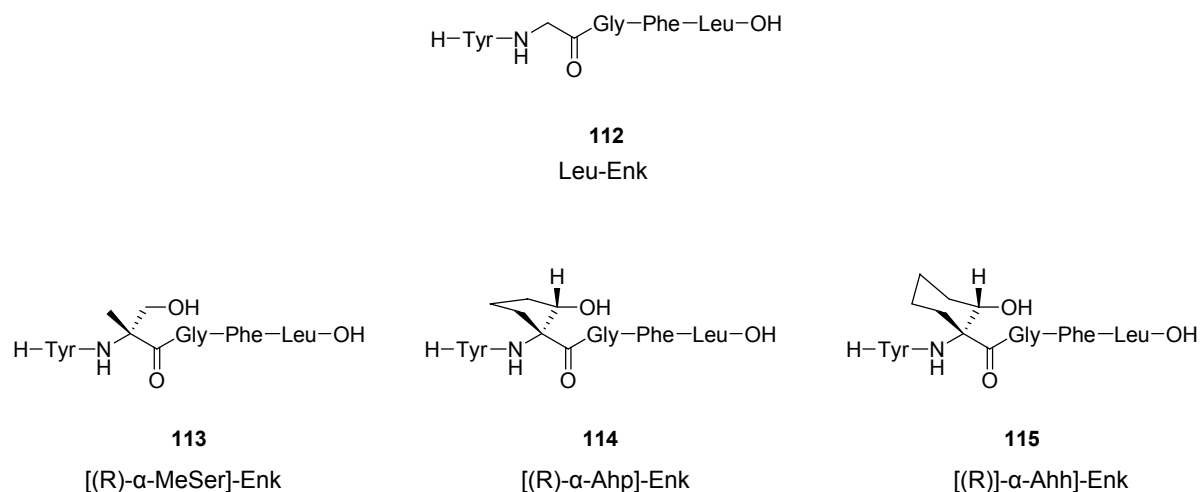

Figure 63: Structures of the enkephalin **112** and three potent analogues **113-115**.

1.2.2. Introduction of Global Restrictions

Besides amino acid modifications several other methods for the preparation of highly active peptidomimetics exist. One example is the introduction of global restrictions into the peptide via cyclisation of the peptide strand. This typically results in a higher *in vivo* stability of the cyclic peptidomimetics compared to their linear analogues. Because of their reduced conformational flexibility they can be used to present divers functionalities in a defined and predictable manner. A variety of different techniques were developed for the synthesis of cyclic peptidomimetics. In principal three ways exist for the formation of cyclic analogues of natural peptides. The first is the connection of the *N*- with the *C*-terminus (head-to-tail), the second is to couple either the *C*- or the *N*-terminus with one of the side chains (backbone/side chain) and the third is to connect two side chains that are not involved in the interaction with other proteins with each other (side chain/side chain).¹⁹⁰

Head-to-Tail Cyclisation

Although new ways were developed for the head-to-tail cyclisation of peptides, most of them are still formed by the cyclisation of activated precursors in solution phase, which means in most cases the use of standard peptide coupling conditions using HOBT/HBTU or HOAt/HATU as activating reagents. One example for the head-to-tail cyclisation of natural products is the previously shown cyclosporine O **107** (see Figure 60).¹⁹¹ This methodology was further used for the preparation of numerous cyclic RGD peptidomimetics, in which the RGD (Arg-Gly-Asp) is flanked by other amino acids to form a ring system. These compounds offer the possibility to present the side chains of the RGD sequence in a specific conformation. Amongst others these cyclopeptides have

been developed as fibrinogen receptor antagonists or as selective $\alpha_v\beta_3$ integrin antagonists for treatment of human tumor metastasis and tumor induced angiogenesis, bone remodeling and osteoporosis.¹⁹²

Besides the standard methods using peptide coupling reactions, other methodologies have also been developed. One example is the ruthenium catalyzed intramolecular nucleophilic aromatic substitution (S_NAr) to form cyclic biphenyl ethers. In Figure 64, two natural products together with some analogues are shown. K-13 (**116**) is a natural noncompetitive inhibitor of angiotensin converting enzyme (ACE),¹⁹³ while OF4949-III (**119**) is a competitive inhibitor for aminopeptidase B. The compound family **117-120** exhibits immunopotentiating activity and were confirmed to have antitumor activity, but they lack classical toxicity.¹⁹⁴

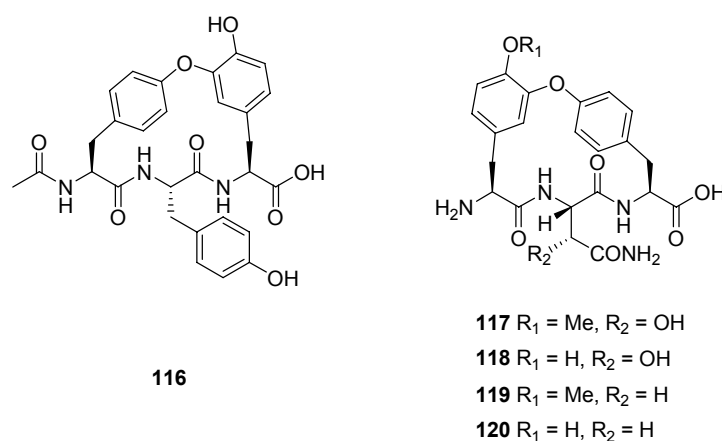

Figure 64: Structures of the naturally occurring protease inhibitor K13 (**116**) and OF4949-III (**119**) together with some analogues **117**, **118** and **120**.

Side chain-to-Side chain Cyclisation

The most common methods to lock peptide chains into defined structures like α -helices by the formation of cyclic analogues are the disulfide linkage *via* the oxidation of two Cys residues and the formation of amide bonds between the side chain residues of the amino acids Lys and Asp/Glu. Disulfide bridging was used for example in the development and synthesis of the cyclic enkephalin analogue **121** which is active at the δ -opiate receptor. In this example the ring system was formed by linking two penicillamine residues *via* a disulfide bridge with each other.

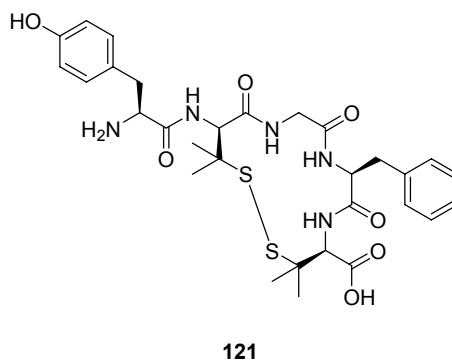

Figure 65: The enkephalin analogue **121** is active at the δ -opiate receptor.

The limitation of these methods is that the use of a single covalent bridge constrains only a limited section of the polypeptide. To overcome this problem several covalent bridges need to be incorporated into one sequence. One example showing the effectiveness of this method is the modification of the 31 *N*-terminal residues of the human parathyroid hormone (hPTH) to deliver the therapeutic osteogenic agent **122**. The introduction of three lactam bridges between the *i* and *i*+4 amino acids results in a highly constrained peptide in which the residues 13-30 are forced into a helical structure. This makes the analogue a much more active compound than the natural sequence.¹⁹⁵

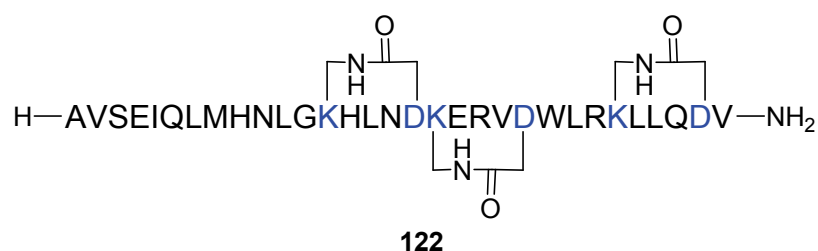

Figure 66: The peptidomimetic **122** consisting of 31 residues of the human parathyroid hormone is stabilized by three lactam bridges.

While disulfide and also lactam bridges effectively stabilize 3D structures, such structural elements are not always stable *in vivo* as they also occur in natural sequences and are susceptible to degradation. To overcome this limitation, cross-links consisting only of hydrocarbons were investigated as replacement for the above shown linking methods. The ring-closing step for example can be performed by a metathesis reaction using a Grubbs catalyst.¹⁹⁶ An interesting approach was the synthesis of Fmoc-protected C^α -tetrasubstituted α -amino acids which are α -methylated and in addition bear a second alkene side chain. They can be used in solid phase peptide synthesis and if two of them are incorporated into one chain they can be cyclized by the use of metal catalysis.¹⁹⁷ One example of this hydrocarbon cyclisation methodology is shown in Figure 67. The mimic of

the minimal death domain BH3 of the pro-apoptotic sub-family of proteins can be forced into a helical conformation through a metathesis reaction. This resulted in a significantly enhanced stability and an altered *in vitro* and *in vivo* activity appeared.^{198, 199}

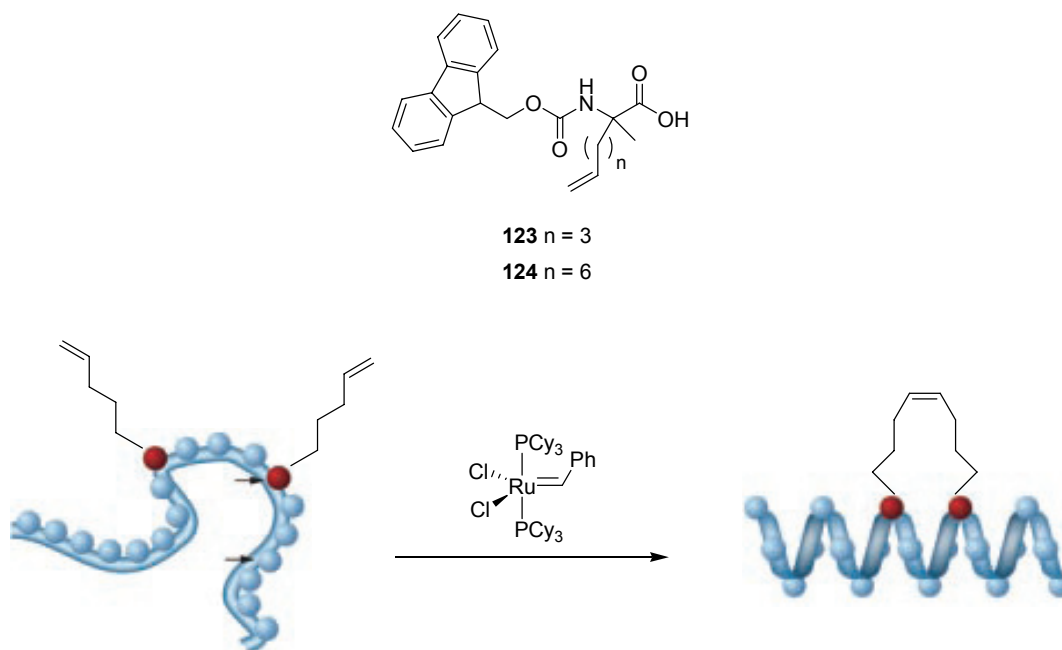

Figure 67: α -Methyl Fmoc-protected unnatural amino acids **123** and **124** (top); scheme of a helix introduction into a peptide sequence *via* a ring-closing metathesis reaction with Grubbs' catalyst (bottom). (adapted from literature¹⁹⁸)

Backbone-to-Side Chain Cyclisation

A further way to introduce global constraints into peptides is the formation of backbone to side chain cyclisations. One example for such a molecule is the cyclic derivative **125** (Tyr-c[-*D*-Orn-2-Nal-*D*-Pro-NMe-Ala]) of the natural occurring β -casomorphin-5. β -Casomorphins are short acyclic peptides derived from the milk protein β -casein and show a high selectivity for the μ -opioid receptor.²⁰⁰ The derivative **125** proved to be a potent and selective μ -opioid receptor agonist with an IC_{50} of 35 nM.²⁰¹

Another example for a backbone-side chain cyclisation is the cyclic peptidomimetic inhibitor of HIV-1 protease **126**. In the mimetic **126** the tripeptide sequence Phe-Ile-Val from the natural peptide Ac-Leu-Val-Phe-CHOHCH₂-{Phe-Ile-Val}-NH₂ was replaced by a cyclic motif consisting of a tyrosine, a leucine and an alkyl amine. In an inhibition assay such peptides showed IC_{50} -values of up to 2 nM.²⁰² Inhibitors for HIV 1 protease are of great interest as this enzyme is essential for the assembly of the viral proteins. A successful inhibition would thus lead to noninfective virions.^{203, 204}

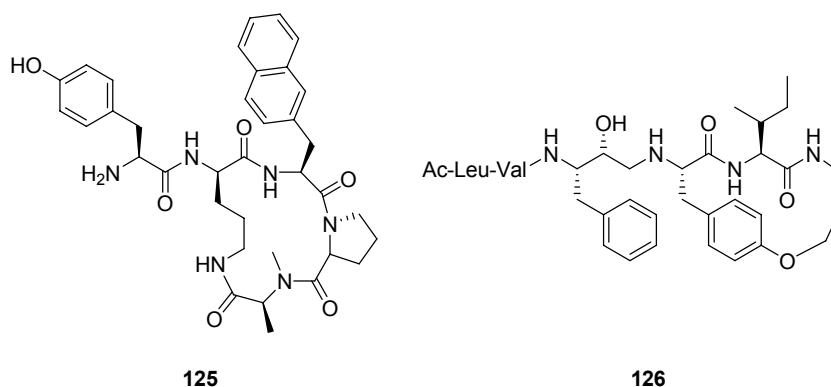

Figure 68: The cyclic β -casomorphin-5 derivative Tyr-c[-D-Orn-2-Nal-D-Pro-NMe-Ala] **125** (left) and a macrocyclic HIV protease inhibitor **126** (right).

1.2.3. Synthetic Backbone Scaffolds

All of the previously shown peptidomimetics still show a more or less peptide like scaffold, however, entirely non-peptidic mimetics have also been developed. The first example of this class of compounds which allows a synthesis in a modular fashion was reported by *Hamilton et al.* in 2002.²⁰⁵ These compounds present their residues with similar distances and angular relationships to those found in the side chains of α -helices. Subsequently, modifications to the initial terphenyl scaffold design were made to improve synthetic accessibility, solubility and flexibility.²⁰⁶ Inhibitors based on the terphenyl scaffold **128** were developed for example to inhibit the interaction of Calmodulin (CaM) with smooth muscle myosin light chain kinase (smMLCK). CaM has a variety of functions in the cell cycle and interacts with a number of proteins including smMLCK which is supposed to play a significant role in the signaling cascade leading to muscle contraction, but it is also supposed to play a role in cancer.²⁰⁷ The designed derivative showed an IC_{50} of 800 nM and with that is one of the most potent CaM antagonists known until now.²⁰⁸

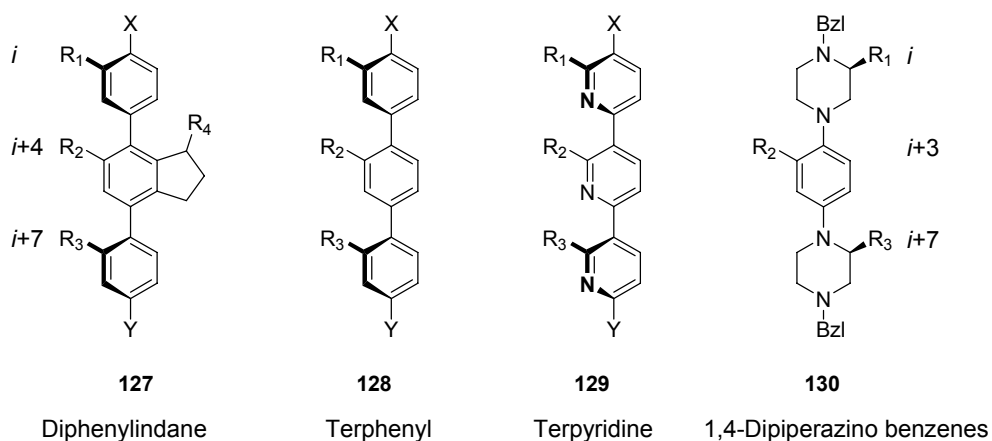

Figure 69: α -Helix mimics developed by *Hamilton et al.* **127-129** and by *König et al.* **130**. The residues R_1 - R_3 are mimics of i , $i+3$, $i+4$ and $i+7$ residues of the helix.

Another interesting approach was the synthesis of 1,4-dipiperazino benzene **130**, using a stepwise transition metal-catalyzed N -arylation of chiral piperazines to a benzene core. The structure determined by X-ray crystallography revealed a geometric arrangement of the side chains resembling the orientation of α -helical i , $i+3$ and $i+7$ residues.²⁰⁹

2. Synthesis of Novel C^α-tetrasubstituted α -Amino Acids

2.1. Introduction

As mentioned previously (see Chapter 1.2.1.2) C^α-tetrasubstituted α -amino acids are an important route to active peptidomimetics. The following factors can be seen as the main motivations for the synthesis and use of these building blocks: (i) The occurrence of C^α-tetrasubstituted α -amino acids in peptaibols.²¹⁰ (ii) The usefulness of these residues in the synthesis of conformationally constrained and enzyme-resistant analogues of biologically active peptides.²¹¹ (iii) The severe restriction of the conformational freedom of peptides containing these residues²¹² which, allows the use of such compounds as precise molecular rulers,²¹³ building blocks in the *de novo* design of peptide and protein mimetics²¹⁴ or suitable models for spectroscopic studies.²¹⁵

C^α-tetrasubstituted α -amino acids are commonly used to introduce constraints into a peptide backbone through the stable quaternary α -carbon and the attached substituents. One way to add even larger constraints is to covalently link the substituents at the α -carbon with each other leading to cyclic C^α-tetrasubstituted α -amino acids. This leads to a change in the chemical reactivity of the surrounding functional groups, like a reduced hydrolysis rate of an amide bond or ester group.^{216, 217}

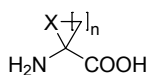

131

X = CH₂, NH, O, S

n = 1-5

Figure 70: General representation of cyclic C^α-tetrasubstituted α -amino acids.

One representative of the group of cyclic unnatural amino acids are the C^α-tetrasubstituted tetrahydrofuran amino acids (TAAs) which were developed by our group.²¹⁸ Attractive features of these amino acids are the easy accessibility in a four step synthesis starting from commercially available starting materials. In addition the amino acids do not only show a stable quaternary stereocenter at the α -carbon of the amino acid but also a second one at the β -carbon. An additional benefit is the variety of aromatic aldehydes which can be brought to reaction with the sulfonium salt **133**, leading to numerous different amino acids with functional groups at the aromatic system.

Scheme 16: Exemplary synthesis pathway leading to the unnatural amino acid *rac*-**135** as racemic mixture.

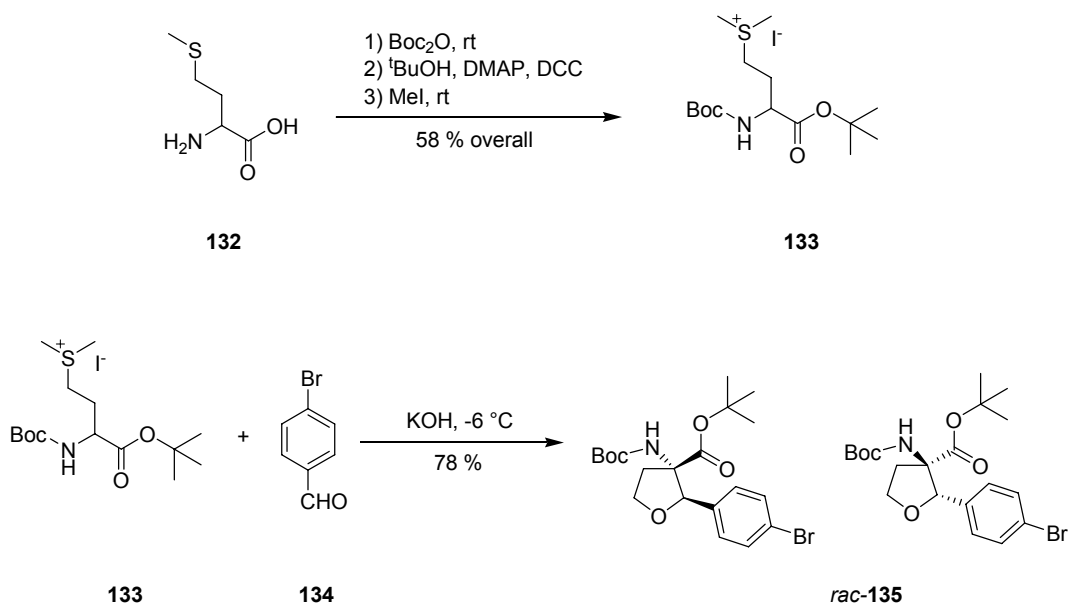

Scheme 16 shows the synthesis of a TAA, starting from methionine **132**, which is two-fold protected and then converted to the sulfonium salt **133**. To form the tetrahydrofuran ring the sulfonium salt **133** is first treated with KOH to abstract the acidic proton of the α -carbon of the amino acid. During this deprotonation, the stereoinformation is lost. The resulting ester enolate can then attack the carbonyl group of the aromatic aldehyde **134**. The intermediate alkoxide substitutes the dimethylsulfide intramolecularly, giving the tetrahydrofuran amino acids *rac*-**135**. During this last step two new stereocenters are formed which can lead to four different stereoisomers. Fortunately the reaction shows a high diastereoselectivity for the formation of the *trans*-product.

However, the TAA synthesis do suffer from some difficulties and limitations: Firstly, the protecting groups used until now are not entirely orthogonal, meaning that the conditions necessary for the saponification of the t butyl-ester group also lead to a cleavage of the Boc-group. Another drawback is the fact that the reaction is not enantioselective, giving always a racemic mixture of the synthesized TAA. Additionally, the strongly basic reaction conditions needed for the abstraction of the α -proton of the methionine are a shortcoming of the synthesis as only aldehydes which lack protons in the α -position like benzaldehyde derivatives are unable to undergo undesired aldol-type side reactions.

In the following some approaches to overcome these limitations will be presented.

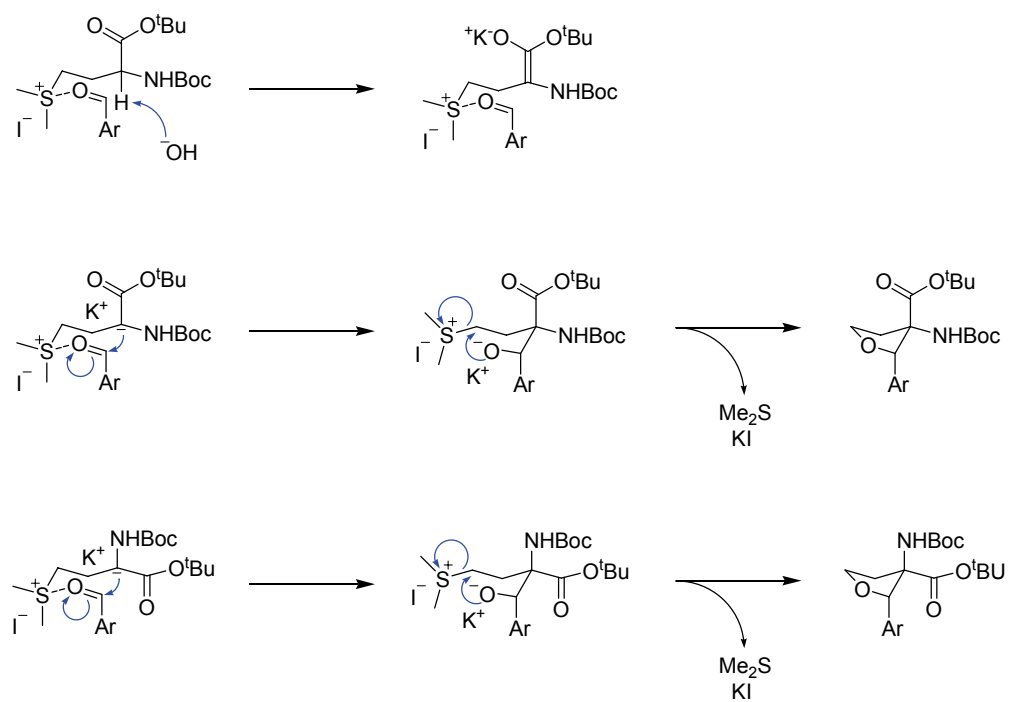
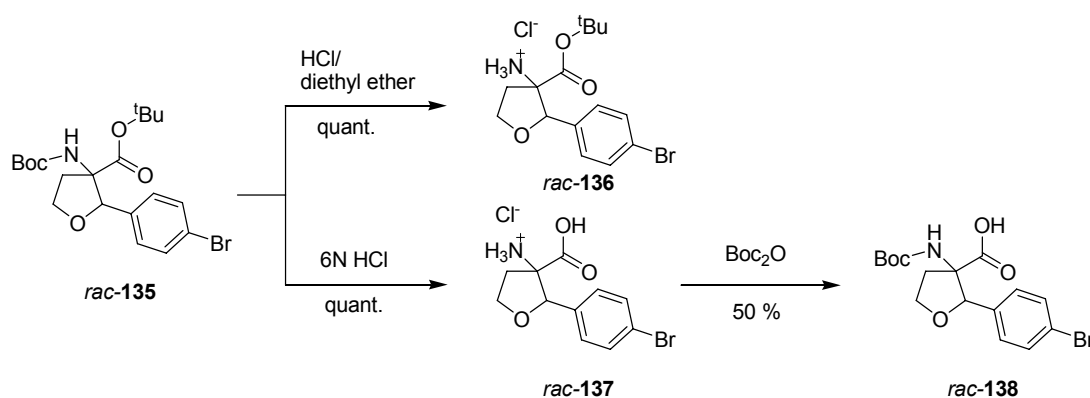

Figure 71: Reaction mechanism for the formation of C^α-tetrasubstituted tetrahydrofuran amino acids as proposed by *König et al.*²¹⁸

2.2. Orthogonal Protecting Groups for the THF Amino Acid

Until now a drawback of the TAA synthesis was that the protecting groups used were not entirely orthogonal. Deprotecting the Boc-group in presence of the ^tbutyl-ester with HCl saturated diethyl ether is possible but the ester group cannot be saponified without eliminating the Boc-group. The only possibility to afford the *N*-terminally protected amino acid *rac*-**138** was to first cleave both groups and then reprotect the amine. This procedure only gave a maximum yield of 50 % which could not be further optimized.

Scheme 17: Deprotection conditions applied to the protected TAA *rac*-**135**.



Therefore we decided to synthesize a tetrahydrofuran amino acid with orthogonal protecting groups. We chose the Cbz-group for amine protection and the ^tbutyl-group for the protection of the carboxylic acid because both are stable to the strongly basic conditions which are used during the cyclisation reaction.

The synthesis was performed similar to the one of the Boc-TAA-O^tBu *rac*-**135**, starting from methionine **132** which was first protected at the *N*-terminus with benzyl carbonochloridate. In a second step the ^tbutyl-ester was introduced using a Steglich-type esterification reaction. After methylation resulting in the sulfonium salt **139**, the cyclisation reaction was performed using para-bromobenzaldehyde **134**. As with Boc-TAA-O^tBu *rac*-**135** the new Cbz-TAA-O^tBu *rac*-**140** was also formed in a highly diastereoselective manner as a racemic mixture in a moderate yield of 48 %.

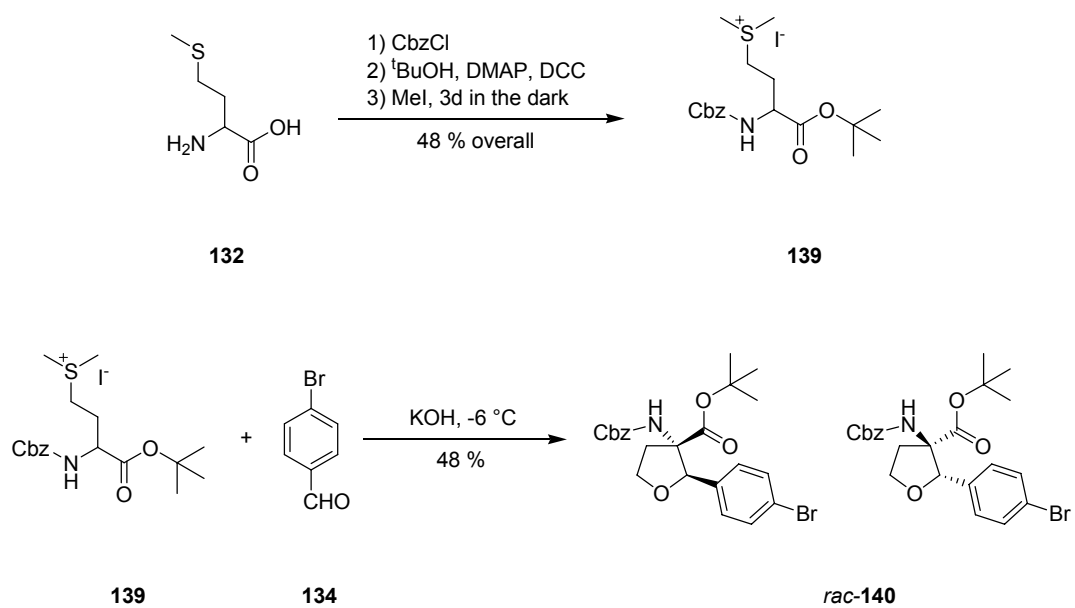
Scheme 18: Synthesis pathway leading to the Cbz-TAA-O^tBu *rac*-140.

2.3. Enantioselective Ring Formation

One of the major shortfalls of the synthesis of unnatural tetrahydrofuran amino acids is the formation of a racemic product. This racemisation occurred because of the mechanism of the reaction which starts with the deprotonation of the α -carbon destroying the stereochemical information in this position. We therefore attempted to induce stereoselectivity in the reaction by the use of an asymmetric auxiliary. We decided to use an optically pure alcohol to replace the ^tbutanol used until now. The alcohol should be easily coupled by a Steglich-type reaction and should also be easy to cleave afterwards to provide the free acid. In addition, the ester function should be stable under the cyclisation conditions. For these reasons, we chose (-)-menthol which is inexpensive, commercially available and can easily be attached to the amino acid as well as cleaved again.

The synthesis followed a similar route as for the Cbz-protected unnatural amino acid *rac*-**140**. It started from methionine **132** which was first protected on the amine function and then coupled in good yields with (-)-menthol.

After the formation of the sulfonium salt **142** the cyclisation reaction was performed using again *para*-bromobenzaldehyde **134** as this afforded high yields and also a high diastereoselectivity so far. The reaction gave selectively the *trans*-product in 69 % yield. Unfortunately no enantioselectivity of the cyclisation reaction was observed and the product TAA (**143** and **144**) was formed again as a mixture but in this case not of two enantiomers but of two diastereomers which allowed us to separate them by flash-chromatography.

The deprotection reactions showed that the Boc-group could be easily cleaved using HCl-saturated diethyl ether but also that the cleavage of the (-)-menthol was a more challenging task. Under basic conditions using KOH in an ethanol/water mixture no saponification occurred even after refluxing for several hours. 6M aqueous HCl which was used for the total deprotection of Boc-TAA-O^tBu *rac*-**135** gave no deprotected product either. Better results were obtained with KOH in a mixture of methanol and water and performing the reaction not under conventional heating in an oil bath but under microwave irradiation. This procedure gave the free acid **146** in reasonable 55 % yield. The free amine **145** and acid **146** were further used in peptide coupling reactions to form dipeptides of tetrahydrofuran amino acids (see Chapter 3.2).

Scheme 19: Synthesis pathway leading to the two Boc-TAA-Omenthol **143** and **144** with exemplary deprotection reactions.

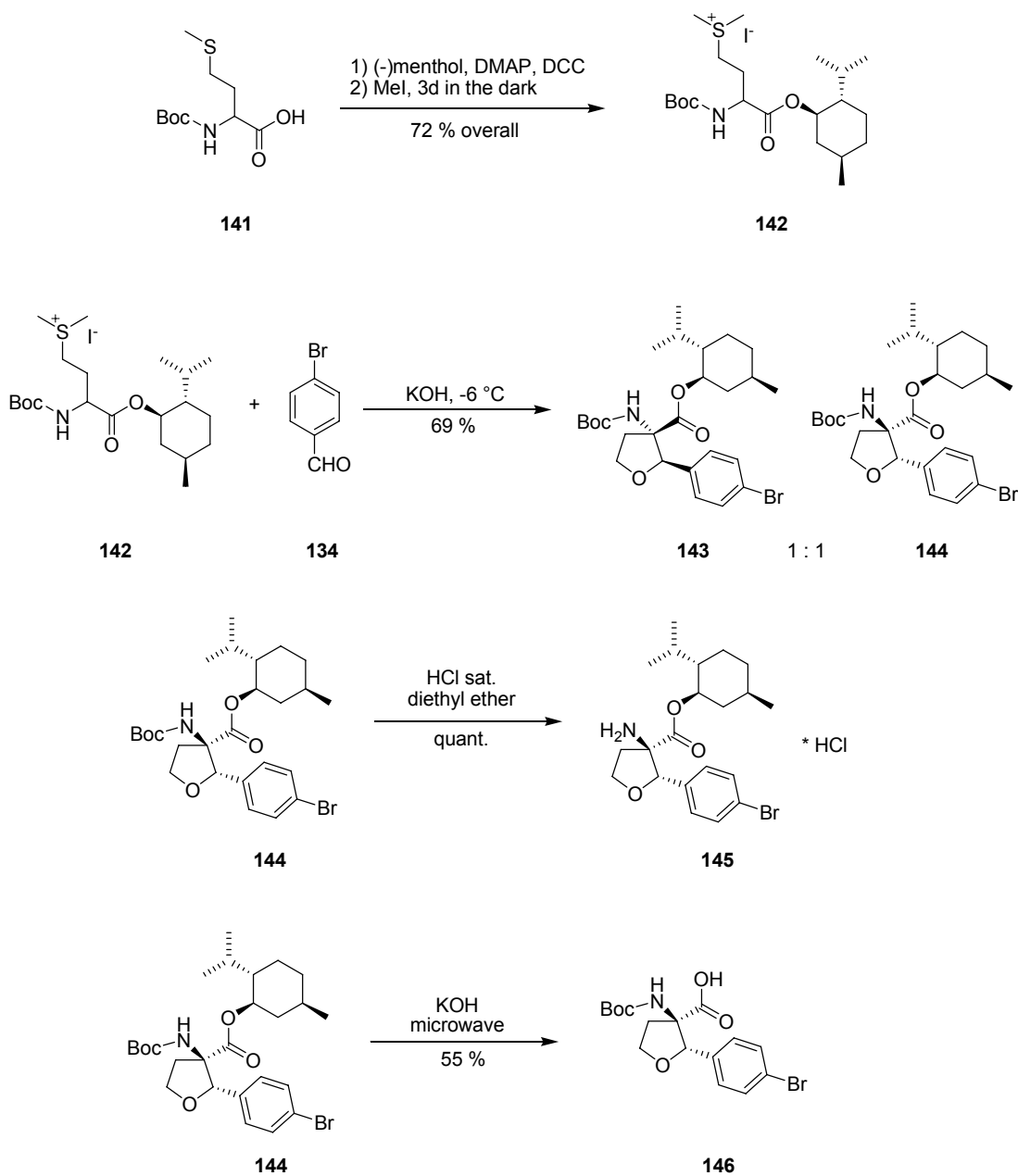

2.4. Aliphatic THF Amino Acids

As shown before (Chapter 2.1) the key step of the TAA synthesis is the ring formation which is an aldol type reaction between the sulfonium salt **133** and an aldehyde: Applying strongly basic conditions leads to the abstraction of the α -proton of the methionine, the aldehyde is nucleophilic attacked by the ester enolate and the displacement of the sulfonium salt substituent by the alkoxy group gives the target TAA. To avoid undesired side reactions under the basic reaction conditions only aldehydes which lack protons in the α -position like benzaldehyde derivatives were used in the TAA-synthesis until now (see Scheme 20).

In the following the synthesis and structural characterization of cyclic tetrahydrofuran C^α-tetrasubstituted amino acids which were prepared from aliphatic aldehydes will be shown.

The major difference between the previously used aromatic aldehydes and their aliphatic counterparts is their ability to undergo an aldol reaction under the strongly basic conditions necessary for the formation of the tetrahydrofuran ring system.

Scheme 20: Cyclisation reaction forming the tetrahydrofuran amino acid (TAA).

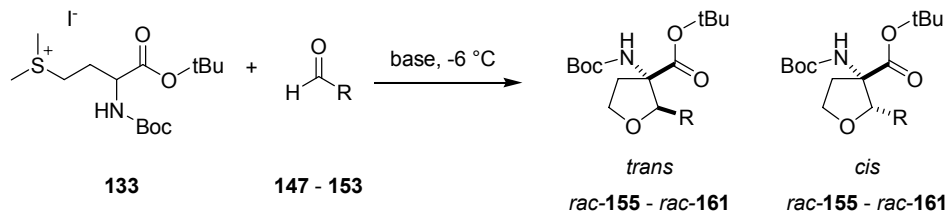

Therefore different bases namely KOH, KO^tBu and CsOH and also different equivalents of sulfonium salt **133**, aldehyde and base were screened to find the optimal conditions for the TAA synthesis. In all cases, dry acetonitrile was used as solvent, and the temperature was kept at -6 °C to improve the diastereoselectivity of the ring formation. n-Butyraldehyde (**147**) was chosen for the first set of reactions to optimize the reaction conditions. Table 2 summarizes the results. In total eight different reaction conditions were tried and the conversion was determined by ¹H-NMR analysis after aqueous workup. Entries 1-3 clearly indicate that cesium hydroxide is the base of choice for the conversion of aliphatic aldehydes which is in contrast to the reactions carried out with aromatic aldehydes where KOH gave the best results.²¹⁸ In the next three experiments (entries 4 – 6), the amount of sulfonium salt **133** was increased with respect to the aldehyde and the optimal amount of base was investigated. The highest yield of TAA were obtained with identical amounts of base and sulfonium salt. To optimize the ratio of aldehyde to sulfonium salt **133**, reactions

with ratios of 1:1.5, 2:1 and 8:1 aldehyde to sulfonium salt **133** were performed (entries 6 – 8). Best results were obtained with a slight excess of the sulfonium salt.

Table 2: Results of the reaction condition optimization of the reaction between the sulfonium salt **133** and the *n*-butyraldehyde **147**.

entry	eq. sulfonium salt 133 ^a	eq. base ^a			yield ^b
		KOH	KO ^t Bu	CsOH	
1	1.1	1.1			16% ^c
2	1.1		1.1		25% ^c
3	1.1			1.1	32% ^c
4	1.5			1.0	21% ^c
5	1.5			1.25	15% ^c
6	1.5			1.5	47% ^c
7	0.5			0.5	24% ^d
8	0.125			0.125	13% ^d

All reactions were performed following GP1.

^a Equivalents are with respect to the *n*-butyraldehyde **147**. ^b Yields were determined by ¹H-NMR and have an error of $\pm 5\%$ as estimated from repeating the reaction of entry 6.











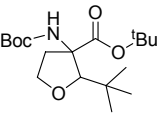
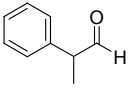
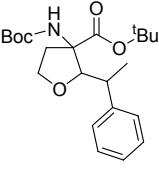

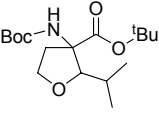
^c Yields are based on the aldehyde as limiting compound.

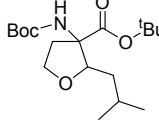
^d Yields are based on the sulfonium salt as limiting compound.

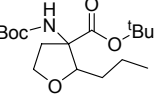
To explore the scope of the reaction a series of aliphatic aldehydes were converted using the optimized reaction conditions. The results are summarized in Table 3 and show that sterically demanding aliphatic aldehydes like pivalaldehyde (**148**) which has a tertiary α -carbon do not undergo the ring closing reaction. Aldehydes with a secondary α -carbon like 2-phenylpropanal (**149**) or isobutyraldehyde (**150**, entries 2 and 3) fail or form the product only in traces. 3-Methylbutanal (**151**, entry 4), which bears a secondary carbon atom in the β -position, gives increased product yields. The best results were obtained for the unbranched *n*-butyraldehyde (**147**) and acetaldehyde (**152**) with yields of 36 % and 28 %, respectively, (entries 5 and 6).

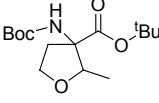
Methacrylaldehyde (**153**, entry 7) was reacted with the sulfonium salt **133** as an example of an unsaturated aldehyde. The corresponding TAA was obtained in 18% yield. To investigate the reactivity of ketones, acetone (**154**) was tested but no TAA product was formed.

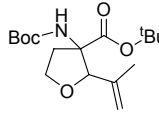
Table 3: Scope of the reaction of sulfonium salt **133** with different aldehydes

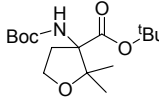
entry	aldehyde	product	isolated yield (%)	<i>trans/cis</i> -ratio ^a
1	 148	 155	-	-
2	 149	 156	-	-
3	 150	 157	2	9/1
4	 151	 158	17	5/1
5	 147	 159	36	3/1
6	 152	 160	28	2/1
7	 153	 161	18	> 95/5
8	 154	 162	-	-

^a The *trans/cis*-ratio was determined by NMR spectroscopy.

The diastereoselectivity of the reaction was also examined. The previously reported ring formation reactions with aromatic aldehydes all showed a *trans*-selectivity,²¹⁸ therefore it was assumed that this is here also the case. To proof this assumption 2-dimensional NMR spectroscopy was performed. The crystal structure obtained from compound **160** shows the *trans*-diastereomer (see Figure 73). In the *trans*-product the proton of the amine and the proton of the THF-CH group are located on the same side of the ring and are therefore in close proximity with a distance determined from the crystal structure of 2.18 Å. This close distance results in a strong NOE cross peak, while for the *cis*-product in which the two protons point to opposite sides of the ring no NOE cross peak occurs (see Figure 72).

By this method the assumption that the *trans*-product is the main diastereomer could be proofed.

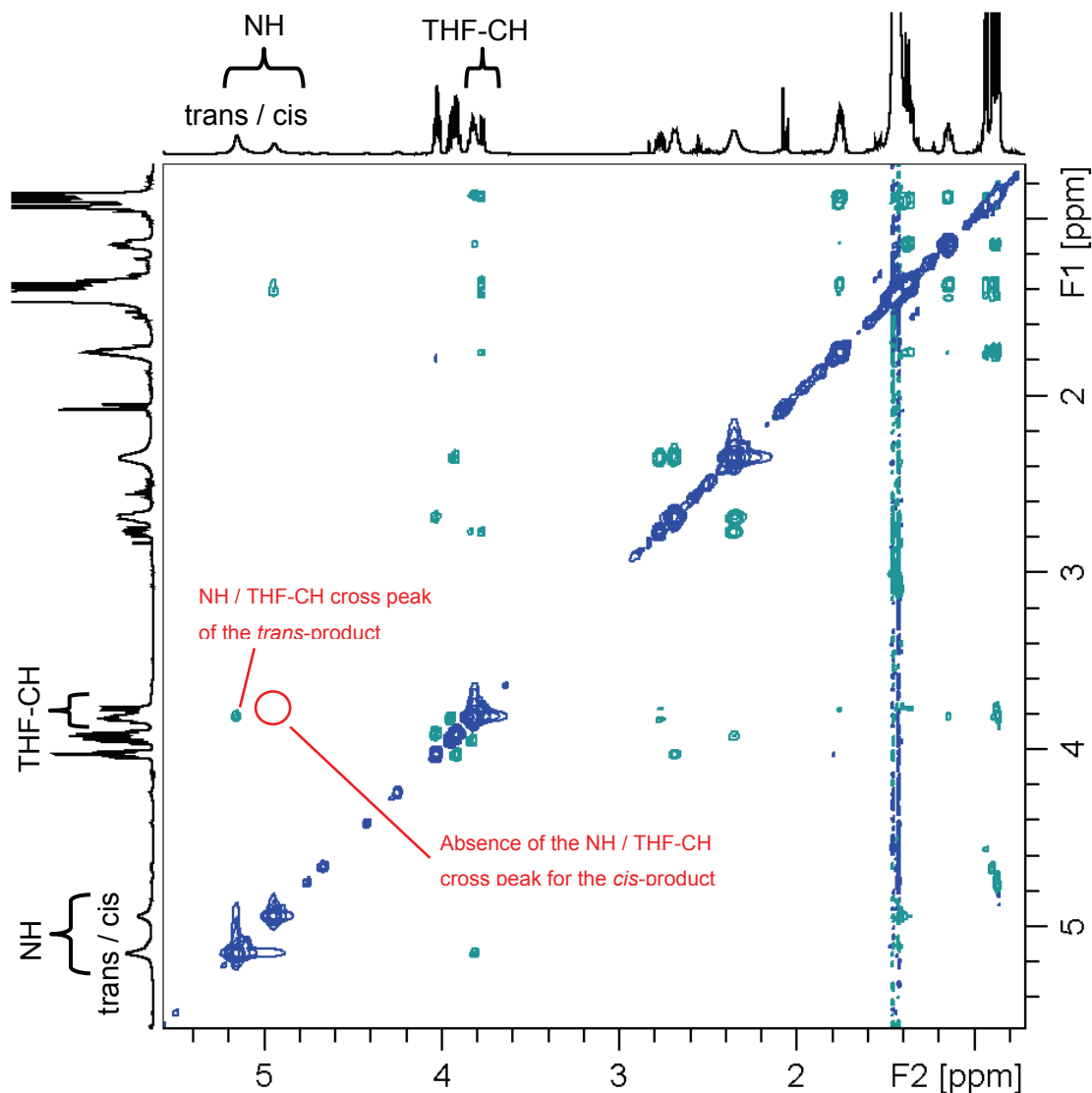

Figure 72: Exemplary NOESY spectra (600 MHz, CDCl₃) of compound **158**.

The diastereoselectivity of the reaction varies: For acetaldehyde (**152**) a ratio of to 2/1 in favor for the *trans*-product was found. This ratio increases to 3/1 (*trans/cis*) for the larger n-butyraldehyde (**147**). With increased steric demand of the aldehydes the ratio shifts in favor of to the *trans*-product as for the 3-methylbutanal (**151**, *trans/cis* = 5/1) and for isobutyraldehyde (**150**, *trans/cis* = 9:1). The highest *trans*-selectivity was found for methacrylaldehyde (**153**) where no *cis*-product could be detected by NMR.

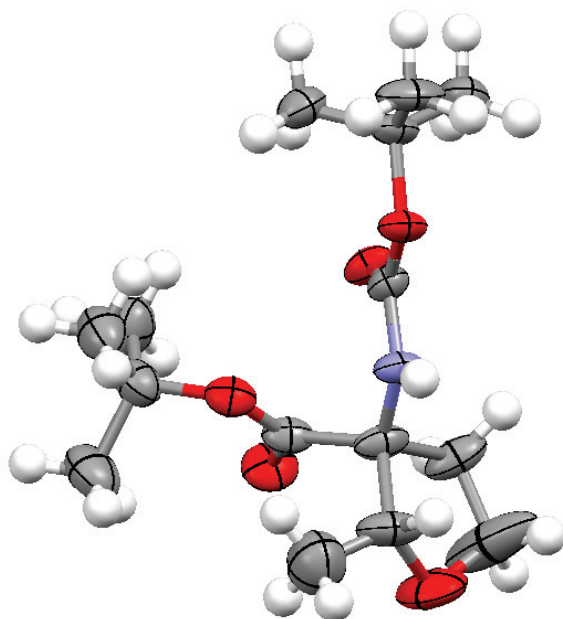

Figure 73: X-Ray structure of compound **160**.

The results gathered, indicate that C^α-tetrasubstituted tetrahydrofuran α -amino acids can be obtained from aliphatic aldehydes in low to moderate yields. The diastereoselectivity of the reaction depends on the steric demand of the aldehyde and varies from *trans/cis*-ratios of 2/1 up to 95/5. Although the scope of the reported reaction is certainly limited, the study shows that from selected aliphatic aldehydes C^α-tetrasubstituted tetrahydrofuran α -amino acids are accessible in synthetically useful yields and selectivities.

2.5. Experimental Part

All reagents and solvents used were of analytical grade purchased from commercial sources and were used without further purification if not stated otherwise. All reactions were carried out under an atmosphere of nitrogen. Acetonitrile was dried previous to use. All aldehydes were distilled shortly before use. Silica gel 60 (230–400 mesh) was used for column chromatography. TLC was carried out with silica gel 60 F₂₅₄ plates. Visualization was accomplished by UV light and Ninhydrin staining. All NMR spectra were recorded on a Bruker Avance 300 (¹H: 300.1 MHz, ¹³C: 75.5 MHz, T = 300 K) and a Bruker Avance 600 (¹H: 600.1 MHz, ¹³C: 150.1 MHz, T = 300 K) instrument with external standard.

The compounds Boc-Met-OH **141** and the sulfonium salt **133** were synthesized according to a literature know procedure.²¹⁸

General Procedure for the tetrahydrofuran amino acid synthesis (GP 1)

In an oven dried Schlenk flask under nitrogen atmosphere the sulfonium salt (0.125 – 1.5 eq. with respect to the aldehyde) was dissolved in dry acetonitrile (5 ml per 1 mmol sulfonium salt). The colorless solution was cooled to -6 °C and the base (0.125 – 1.5 eq. with respect to the aldehyde) followed by the freshly distilled aldehyde were added. The mixture was stirred at -6 °C for 4-7 hours. After complete consumption of starting material the reaction mixture was quenched with water (4 ml per mmol sulfonium salt) and was extracted with diethyl ether (1 x 4 ml/mmol, 2 x 5 ml/mmol sulfonium salt). The combined organic layers were washed with brine solution and dried over MgSO₄. After removal of the solvent under reduced pressure the crude product was purified by flash chromatography using mixtures of diethyl ether and petrol ether (10:90 → 20:80) as eluent.

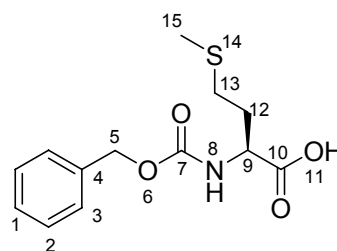

(S)-2-(Benzyloxycarbonylamino)-4-(methylthio)butanoic acid (163):

L-Methionine **132** (2.00 g, 13.4 mmol) was dissolved in 15 ml 1M aqueous sodium hydroxide solution and cooled to 0 °C in an ice bath. Under vigorous stirring benzyl carbonochloridate (1.79 ml, 12.7 mmol) was added drop by drop. After 45 minutes 50 ml of water were added and the mixture was extracted three times with 50 ml of EtOAc each. Afterwards the solution was dried over MgSO₄ and concentrated under reduced pressure to give the product as colorless oil (3.07 g, 10.8 mmol, 85 %).

MP 59 °C. - **¹H-NMR** (300 MHz, CDCl₃): δ = 1.91-2.29 (m, 5 H, 12 + 15), 2.57 (t, ³J_{H,H} = 7.4, 2 H, 13), 4.45-4.61 (m, 1 H, 9), 5.13 (s, 2 H, 5), 5.44 (d, ³J_{H,H} = 7.9, 1 H, 8), 7.28-7.44 (m, 5 H, H-Ar). - **¹³C-NMR** (75 MHz, CDCl₃): δ = 15.4 (+, 1 C, 15), 29.9 (-, 1 C, 13), 31.6 (+, 1 C, 12), 53.0 (+, 1 C, 9), 67.3 (+, 1 C, 5), 128.2 (+, 2 C, 3), 128.3 (+, 1 C, 1), 128.6 (+, 2 C, 2), 136.0 (C_{quat}, 1 C, 4), 156.1 (C_{quat}, 1 C, 7), 176.6 (C_{quat}, 1 C, 10). - **MS** (CI, NH₃): *m/z* (%) = 301.1 (100) [MNH⁺], 284.1 (14) [MH⁺]. - **IR** (NEAT) [cm⁻¹]: $\tilde{\nu}$ = 3304, 2969, 2917, 1739, 1682, 1647, 1539, 1400, 1293, 1269, 1203, 1061, 1027, 961, 910, 810, 744. - **MF** C₁₃H₁₇NO₄S. - **MW** 283,34.

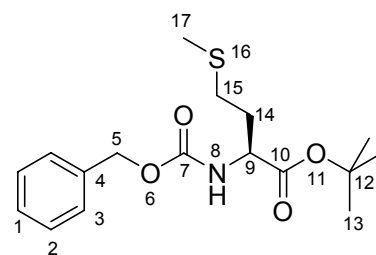

(S)-tert-Butyl 2-(benzyloxycarbonylamino)-4-(methylthio)butanoate (164):

2-(Benzyloxycarbonylamino)-4-(methylthio)butanoic acid **163** (3.00 g, 10.6 mmol) was dissolved under a nitrogen atmosphere in 50 ml of dry DCM and cooled to 0 °C in an ice bath. To this solution DMAP (108 mg, 0.88 mmol) and ^tbutanol (1.21 ml, 12.7 mmol) were added. Under vigorous stirring dicyclohexyl carbonate (2.84 g, 13.8 mmol) was slowly added in portions. The mixture was stirred at 0 °C for 2 hours and was then allowed to warm to room temperature and was stirred for additional 12 hours. The urea was filtered off and washed twice with 25 ml of DCM. The solvent was evaporated under reduced pressure. The crude product was then purified by column chromatography on silica gel (EtOAc:PE 30 :70, R_f = 0.48) to give the product as colorless oil (1.84 g, 6.02 mmol, 57 %).

¹H-NMR (300 MHz, CDCl₃): δ = 1.46 (s, 9 H, 13), 1.82-2.20 (m, 5 H, 14 + 17), 2.41-2.61 (m, 2 H, 15), 4.25-4.44 (m, 1 H, 9), 5.11 (s, 2 H, 5), 5.39 (d, ³J_{H,H} = 7.4, 1 H, 8), 7.28-7.43 (m, 5 H, H-Ar). – ¹³C-NMR (75 MHz, CDCl₃): δ = 15.5 (+, 1 C, 17), 28.0 (+, 3 C, 13), 29.9 (-, 1 C, 15), 32.5 (+, 1 C, 14), 53.8 (+, 1 C, 9), 67.0 (+, 1 C, 5), 82.4 (C_{quat}, 1 C, 12), 128.1 (+, 2 C, 3), 128.2 (+, 1 C, 1), 128.5 (+, 2 C, 2), 136.3 (C_{quat}, 1 C, 4), 155.9 (C_{quat}, 1 C, 7), 171.0 (C_{quat}, 1 C, 10). – MS (Cl, NH₃): *m/z* (%) = 284.0 (7) [MH⁺ - C₄H₈], 301.1 (52) [MNH₄⁺ - C₄H₈], 340.1 (15) [MH⁺], 357.1 (100) [MNH₄⁺]. – IR (NEAT) [cm⁻¹]: $\tilde{\nu}$ = 2979, 2917, 1708, 1523, 1455, 1368, 1224, 1149, 1046, 965, 845, 738, 696. – MF C₁₇H₂₅NO₄S. – MW 339.45.

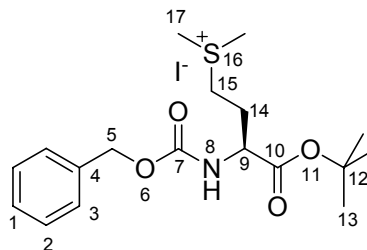

(S)-3-(Benzyloxycarbonylamino)-4-tert-butoxy-4-oxobutyl dimethylsulfonium iodide (139):

tert-Butyl 2-(benzyloxycarbonylamino)-4-(methylthio)butanoate **164** (3.00 g, 10.6 mmol) was dissolved in 32 ml methyl iodide (3 ml/mmol) and stirred for three days at room temperature in the dark. The solution was cooled to 0 °C in an ice bath and 32 ml of heptane (3 ml/mmol) were added to precipitate the product. The mixture was kept at 0 °C in the dark for four hours to complete the precipitation. The hygroscopic and light sensitive product was obtained after filtration and washing with ice-cold heptane as a colorless solid (1.39 g, 2.89 mmol, 98%) in analytically pure form.

MP 35-37 °C. - **¹H-NMR** (300 MHz, CDCl₃): δ = 1.46 (s, 9 H, 13), 2.20-2.49 (m, 2 H, 14), 3.19 (s, 3 H, 17), 3.23 (s, 3 H, 17), 3.59-3.81 (m, 1 H, 15), 3.85-4.02 (m, 1 H, 15), 4.21-4.38 (m, 1 H, 9), 5.10 (s, 2 H, 5), 6.09 (d, ³J_{H,H} = 7.1, 1 H, 8), 7.28-7.47 (m, 5 H, 1-3). - **¹³C-NMR** (75 MHz, CDCl₃): δ = 25.7 (+, 1 C, 17), 26.0 (+, 1 C, 17), 28.0 (+, 3 C, 13), 31.9 (-, 1 C, 14), 40.5 (+, 1 C, 15), 53.2 (+, 1 C, 9), 67.2 (+, 1 C, 5), 83.5 (C_{quat}, 1 C, 12), 128.2 (+, 2 C, 3), 128.3 (+, 1 C, 1), 128.6 (+, 2 C, 2), 136.3 (C_{quat}, 1 C, 4), 156.5 (C_{quat}, 1 C, 7), 169.9 (C_{quat}, 1 C, 10). - **MS** (ES, DCM/MeOH + 10 mmol/l NH₄OAc): m/z (%) = 354.1 (100) [M⁺]. - **IR** (NEAT) [cm⁻¹]: $\tilde{\nu}$ = 2980, 2928, 1707, 1518, 1238, 1151, 1047, 740, 698. - **MF** C₁₈H₂₈NO₄SI. - **MW** 481.39.

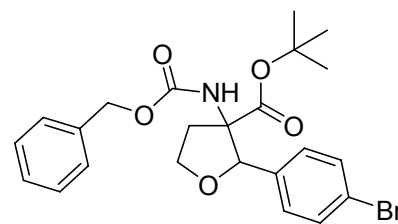

rac-tert-butyl 3-(benzyloxycarbonylamino)-2-(4-bromophenyl)-tetrahydrofuran-3-carboxylate (rac-140):

Synthesis followed **GP 1** using (3-(benzyloxycarbonylamino)-4-tert-butoxy-4-oxobutyl)-dimethylsulfonium iodide **139** (4.68 g, 9.73 mmol, 1.2 eq.), potassium hydroxide (546 mg, 9.73, 1.2 eq.) and para-bromobenzaldehyde **133** (1.50 g, 8.11 mmol, 1 eq.). The product was purified with a 80:20 mixture of PE:diethyl ether ($R_f = 0.15$) to give a white crystalline solid in 48 % yield (1.85 g, 3.90 mmol).

MP 133-135 °C. – **¹H-NMR** (300 MHz, CDCl₃): $\delta = 1.11$ (s, 9 H, ^tBu), 2.54-2.81 (m, 2 H, CH₂), 4.22-4.37 (m, 2 H, S-CH₂), 5.08-5.21 (m, 3 H, CH₂-Cbz + CH), 6.00 (bs, 1 H, NH), 7.20 (d, ³J_{H,H} = 7.9, 2 H, CH-Ar), 7.28-7.45 (m, 7 H, CH-Cbz, CH-Ar). – **¹³C-NMR** (75 MHz, CDCl₃): $\delta = 27.4$ (+, 3 C, CH₃-^tBu), 35.8 (-, 1 C, CH₂), 66.8 (-, 1 C, O-CH₂), 67.9 (-, 1 C, CH₂-Bzl), 69.5 (C_{quat}, 1 C, C-NH), 83.0 (C_{quat}, 1 C, C-^tBu), 83.8 (+, 1 C, CH), 121.7 (C_{quat}, 1 C, C-Br), 127.7 (+, 2 C, CH-Bzl), 128.2 (+, 2 C, CH-Bzl), 128.3 (+, 1 C, CH-Bzl), 128.6 (+, 2 C, CH-Ar), 131.0 (+, 2 C, CH-Ar), 136.2 (C_{quat}, 1 C, C-Ar), 136.5 (C_{quat}, 1 C, C-Ar), 154.6 (C_{quat}, 1 C, CO-Bzl), 169.9 (C_{quat}, 1 C, COO^tBu). – **MS** (ES, DCM/MeOH + 10 mmol/l NH₄OAc): m/z (%) = 476.2 (7) [MH⁺], 495.2 (100) [MNH₄⁺], 476.1 (100) [M – H⁺], 536.2 (10) [M + CH₃COO⁻]. – **Elemental analysis** calcd. (%) for C₂₃H₂₆BrNO₅ (524.49): C 57.99, H 5.50, N 2.94; found: C 58.04, H 5.55, N 2.82. – **IR** (NEAT) [cm⁻¹]: $\tilde{\nu} = 3334, 2977, 2947, 2860, 1702, 1593, 1524, 1491, 1361, 1247, 1154, 1073, 1011, 986, 827, 790, 750, 697$. – **MF** C₂₃H₂₆BrNO₅. – **MW** 476,36.

X-Ray structure and crystal data of *rac*-**140**:

Orthorhombic; space group: P 21 21 21; cell dimensions: $a = 5.70000 \text{ \AA}$, $\alpha = 90^\circ$, $b = 16.24330(10) \text{ \AA}$, $\beta = 90^\circ$, $c = 23.2665(2) \text{ \AA}$, $\gamma = 90^\circ$; $V = 2154.17(2) \text{ \AA}^3$; $Z = 4$, $D_x = 1.469 \text{ Mg/m}^3$; $\mu = 2.893 \text{ mm}^{-1}$; $F(000) = 984$. Data collection: $T = 123 \text{ K}$; graphite monochromator. A translucent colorless crystal with dimensions of $0.440 \times 0.080 \times 0.060 \text{ mm}$ was used to measure 45343 reflections (3404 unique reflections, $R_{\text{int}} = 0.1645$) from 3.32° to 62.28° on a Oxford Diffraction Gemini Ultra diffractometer with the omega-scan method. Structure refinement: The F^2 value was refined using the full-matrix least squares refinement method, with a goodness-of-fit O_f of 1.038 for all reflections and 275 parameters.

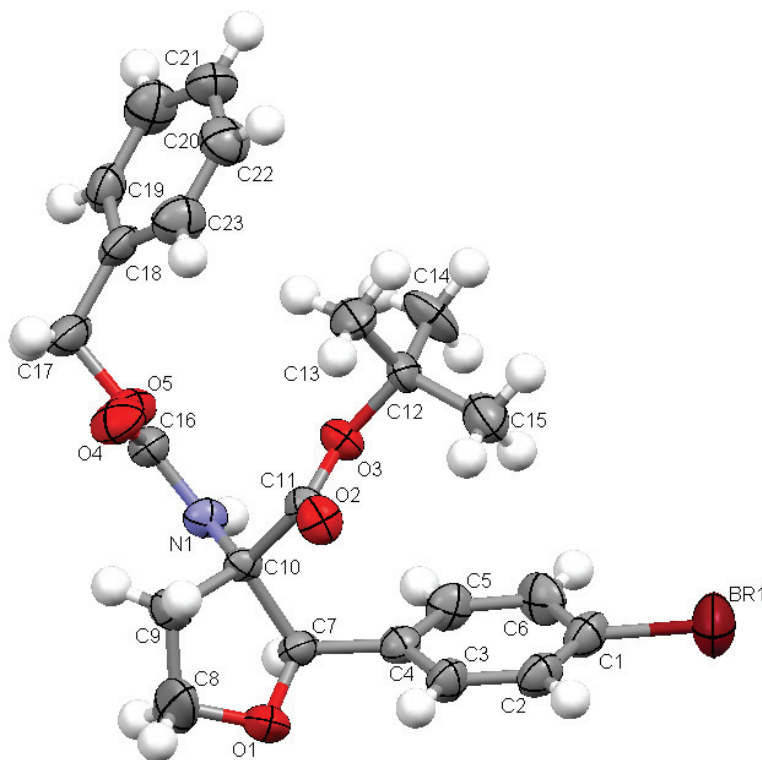

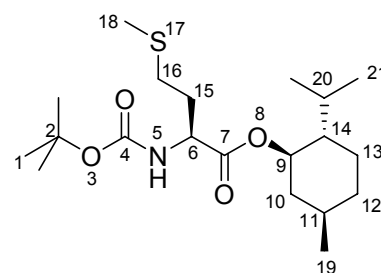

(S)-(1R,2S,5R)-2-Isopropyl-5-methylcyclohexyl 2-(tert-butoxycarbonylamino)-4-(methylthio) butanoate (165):

Boc-Met-OH **141** (10.0 g, 40.1 mmol) was dissolved under a nitrogen atmosphere in 200 ml of dry DCM and cooled to 0 °C in an ice bath. To this solution DMAP (408 mg, 3.34 mmol) and (-)-menthol (7.52 ml, 48.1 mmol) were added. Under vigorous stirring dicyclohexyl carbonate (10.8 g, 52.1 mmol) was slowly added in portions. The mixture was stirred at 0 °C for 2 hours and was then allowed to warm to room temperature and was stirred for additional 12 hours. The urea was filtered off and washed twice with 50 ml of DCM. The solvent was evaporated under reduced pressure. The crude product was then purified by column chromatography on silica gel (PE:diethyl ether 80:20, R_f = 0.20) to give the product as colorless solid (13.3 g, 34.3 mmol, 86 %).

MP 59-60 °C. – **¹H-NMR** (300 MHz, CDCl₃): δ = 0.74 (d, ³J_{H,H} = 6.9, 3 H, 19), 0.88 (d, ³J_{H,H} = 4.4, 3 H, 21), 0.90 (d, ³J_{H,H} = 4.1, 3 H, 21), 0.92-1.26 (m, 3 H), 1.32-1.65 (m, 11 H), 1.63-1.75 (m, 2 H), 1.79 (2.04 (m, 3 H), 2.07-2.18 (m, 4 H), 2.45-2.61 (m, 2 H, 16), 4.36 (dd, ³J_{H,H} = 7.0, ³J_{H,H} = 12.5, 1 H, 6), 4.73 (dt, ³J_{H,H} = 4.4, ³J_{H,H} = 11.0, 1 H, 9), 4.36 (d, ³J_{H,H} = 5.1, 1 H, 5). – **¹³C-NMR** (75 MHz, CDCl₃): δ = 15.5 (+, 1 C, 21), 16.2 (+, 1 C, 21), 20.8 (+, 1 C, 18), 22.0 (+, 1 C, 19), 23.3 (-, 1 C, 13), 26.1 (+, 1 C, 20), 28.3 (+, 3 C, 1), 29.9 (-, 1 C, 16), 31.4 (+, 1 C, 11), 32.6 (-, 1 C, 15), 34.1 (-, 1 C, 12), 40.7 (-, 1 C, 10), 46.9 (+, 1 C, 14), 53.0 (+, 1 C, 6), 75.6 (+, 1 C, 9), 79.9 (C_{quat}, 1 C, 2), 155.3 (C_{quat}, 1 C, 4), 171.8 (C_{quat}, 1 C, 7). - 30.1 (-, 1 C, 9), 53.8 (+, 1 C, 6), 70.0 (-, 1 C, 17), 80.1 (C_{quat}, 1 C, 2), 114.9 (+, 1 C, 14), 128.8 (+, 2 C, 19/20), 128.9 (+, 2 C, 19/20), 129.2 (C_{quat}, 1 C, 21), 133.9 (C_{quat}, 1 C, 10), 136.8 (+, 1 C, 12), 139.6 (C_{quat}, 1 C, 18), 148.4 (C_{quat}, 1 C, 15), 173.9 (C_{quat}, 1 C, 7). – **MS** (CI, NH₃): *m/z* (%) = 405.2 (100) [MNH₄⁺], 388.2 (54) [MH⁺], 349.1 (45) [MNH₄⁺ - C₄H₈], 288.2 (16) [MH⁺ - Boc]. – **Elemental analysis** calcd. (%) for C₂₀H₃₇NO₄S (387.58): C 61.98, H 9.62, N 3.61; found: C 61.81, H 9.33, N 3.47. – **IR** (NEAT) [cm⁻¹]: $\tilde{\nu}$ = 3345, 2927, 2970, 2121, 1703, 1508, 1458, 1365, 1310, 1275, 1247, 1227, 1152, 1055, 1001, 960, 866, 789. – **MF** C₂₀H₃₇NO₄S. – **MW** 387.58.

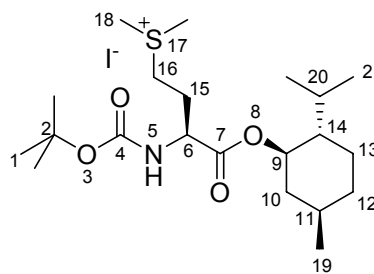

(S)-(3-(tert-Butoxycarbonylamino)-4-((1S,2S,5R)-2-isopropyl-5-methylcyclohexyloxy)-4-oxobutyl) di-methylsulfonium iodide (**142**):

(S)-(1R,2S,5R)-2-Isopropyl-5-methylcyclohexyl 2-(tert-butoxycarbonylamino)-4-(methylthio) butanoate **165** (5.00 g, 12.9 mmol) was dissolved in 39 ml methyl iodine (3 ml/mmol) and stirred for three days at room temperature in the dark. The solution was cooled to 0 °C in an ice bath and 39 ml of heptane (3 ml/mmol) were added and the methyl iodine was evaporated under reduced pressure until the product started to precipitate. The mixture was kept at 0 °C in the dark for four hours to complete precipitation. The hygroscopic and light sensitive product was obtained after filtration and washing with ice-cold heptane as a colorless solid (10.8 g, 5.71 mmol, 84%) in analytically pure form.

MP 42 °C. – **¹H-NMR** (300 MHz, CDCl₃): δ = 0.68 (d, ³J_{H,H} = 6.9, 3 H, 19), 0.81-0.88 (m, 7 H, 2 CH₃ + CH), 0.92-1.16 (m, 2 H, CH₂), 1.14-1.23 (m, 2 H, CH₂), 1.38 (s, 9 H, CH₃), 1.56-1.69 (m, 2H, CH₂), 1.71-1.84 (m, 1 H, CH), 1.85-1.95 (m, 1 H, CH), 2.13-2.41 (m, 2 H, CH₂), 3.61-3.79 (m, 1 H, CH₂), 3.88-4.03 (m, 1 H, CH₂), 4.11-4.36 (m, 1 H, CH), 4.69 (dt, ³J_{H,H} = 4.5, ³J_{H,H} = 10.8, 1 H, CH), 5.62 (d, ³J_{H,H} = 5.8, 1 H, NH). – **¹³C-NMR** (75 MHz, CDCl₃): δ = 14.1 (+, 1 C, CH₃), 16.2 (+, 1 C, CH), 20.8 (+, 1 C, CH₃), 22.0 (+, 1 C, CH₃), 22.7 (-, 1 C, CH₂), 23.1 (-, 1 C, CH₂), 25.9 (+, 1 C, CH₃), 26.1 (+, 1 C, CH₃), 28.3 (+, 3 C, CH₃), 31.4 (+, 1 C, CH), 31.9 (- 1 C, CH₂), 34.0 (-, 1 C, CH₂), 40.7 (-, 1 C, CH₂), 46.7 (+, 1 C, CH), 52.1 (+, 1 C, CH), 76.6 (-, 1 C, CH), 80.8 (C_{quat}, 1 C, C(CH₃)₃), 155.9 (C_{quat}, 1 C, CO), 170.1 (C_{quat}, 1 C, CO). – **MS** (ES, DCM/MeOH + 10 mmol/l NH₄OAc): *m/z* (%) = 2402.3 (100) [M⁺], 931.6 (100) [2M⁺ + I⁻]. – **IR** (NEAT) [cm⁻¹]: $\tilde{\nu}$ = 2957, 2925, 2870, 2361, 1704, 1508, 1456, 1366, 1310, 1274, 1246, 1161, 1048, 982, 784. – **MF** C₂₁H₄₀NO₄SI . – **MW** 529.52.

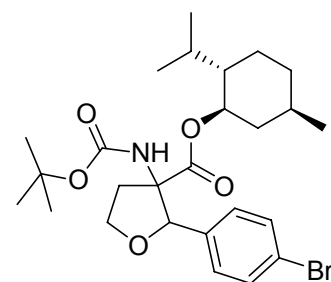

(1R,2S,5R)-2-isopropyl-5-methylcyclohexyl 2-(4-bromophenyl)-3-(tert-butoxycarbonyl-amino)-tetrahydrofuran-3-carboxylate (143/144):

Synthesis followed **GP 1** using the sulfonium salt **142** (601 mg, 1.14 mmol, 1.4 eq.), potassium hydroxide (64 mg, 1.14, 1.4 eq.) and para-bromobenzaldehyde **133** (150 mg, 0.81 mmol, 1 eq.). The product was purified with a 90:10 mixture of PE:diethyl ether (R_f = 0.10, 0.17) to give a 1:1 mixture of diastereomers as white crystalline solid in 69 % yield (293 mg, 0.56 mmol).

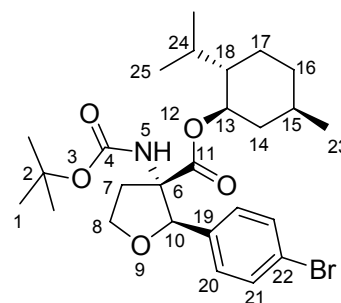

143:

MP 52-53 °C. – **¹H-NMR** (600 MHz, COSY, CDCl₃): δ = 0.44 (q, ³J_{H,H} = 11.5, 1 H, 14), 0.61 (d, ³J_{H,H} = 6.6, 3 H, 23), 0.69-0.78 (m, 1 H, 16), 0.80 (d, ³J_{H,H} = 6.6, 3 H, 25), 0.82 (d, ³J_{H,H} = 7.0, 3 H, 25), 0.86-0.94 (m, 1 H, 17), 1.15-1.22 (m, 1 H, 14), 1.24-1.30 (m, 2 H, 15 + 18), 1.48 (s, 9 H, 1), 1.52-1.62 (m, 3 H, 16 + 17 + 24), 2.60-2.67 (m, 1 H, 7), 2.68-2.76 (m, 1 H, 7), 4.25-4.33 (m, 2 H, 8), 4.41 (dt, ³J_{H,H} = 4.4, ³J_{H,H} = 10.9, 1 H, 13), 5.12 (s, 1 H, 10), 5.71 (s, 1 H, 5), 7.20 (d, ³J_{H,H} = 8.3, 2 H, 20), 7.40 (d, ³J_{H,H} = 8.6, 2 H, 21). – **¹³C-NMR** (150 MHz, HSQC, HMBC, CDCl₃): 15.7 (+, 1 C, 23), 20.9 (+, 1 C, 25), 21.9 (+, 1 C, 25), 22.8 (-, 1 C, 17), 25.8 (+, 1 C, 24), 28.4 (+, 3 C, 1), 31.1 (+, 1 C, 15), 33.9 (-, 1 C, 16), 35.6 (-, 1 C, 7), 39.8 (-, 1 C, 14), 46.7 (+, 1 C, 18), 67.8 (-, 1 C, 8), 69.4 (C_{quat}, 1 C, 6), 76.5 (+, 1 C, 13), 80.1 (C_{quat}, 1 C, 3), 84.0 (+, 1 C, 10), 121.8 (C_{quat}, 1 C, 22), 127.7 (+, 2 C, 20), 131.2 (+, 2 C, 21), 136.5 (C_{quat}, 1 C, 19), 154.3 (C_{quat}, 1 C, 4), 171.0 (C_{quat}, 1 C, 11). – **MS** (ES, DCM/MeOH + 10 mmol/l NH₄OAc): m/z (%) = 524.3 (29) [MH⁺], 543.4 (100) [M + NH₄⁺], 524.4 (100) [M – H⁺], 582.4 (81) [M + CH₃COO⁻]. – **Elemental analysis** calcd. (%) for C₂₆H₃₈BrNO₅ (524.49): C 59.42, H 7.08, N 2.66; found: C 59.54, H 7.30, N 2.67. – **IR**

(NEAT) [cm^{-1}]: $\tilde{\nu}$ = 2957, 2930, 2870, 1714, 1591, 1485, 1367, 1269, 1160, 1103, 1069, 1011, 847, 757. – **MF** C₂₆H₃₈BrNO₅. – **MW** 524.49.

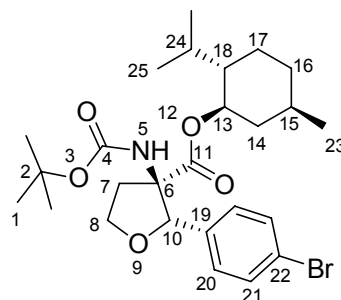
**144:**

MP 88-90 °C. – **¹H-NMR** (600 MHz, COSY, CDCl₃): δ = 0.35-0.46 (m, 1 H, 14), 0.59 (d, ³J_{H,H} = 6.6, 3 H, 23), 0.72-0.76 (m, 1 H, 16), 0.79 (d, ³J_{H,H} = 6.9, 3 H, 25), 0.81 (d, ³J_{H,H} = 6.4, 3 H, 25), 0.88-0.92 (m, 1 H, 17), 1.16-1.23 (m, 2 H, 14 + 18), 1.25-1.32 (m, 1 H, 15), 1.47 (s, 9 H, 1), 1.50-1.55 (m, 1 H, 24), 1.56-1.58 (m, 1 H, 16), 1.58-1.61 (m, 1 H, 17), 2.62-2.71 (m, 1 H, 7), 2.80 (dt, ³J_{H,H} = 8.3, ³J_{H,H} = 13.0, 1 H, 7), 4.18 (q, ³J_{H,H} = 8.1, 1 H, 8), 4.34 (dt, ³J_{H,H} = 4.2, ³J_{H,H} = 8.4, 1 H, 8), 4.40 (dt, ³J_{H,H} = 4.4, ³J_{H,H} = 10.8, 1 H, 13), 4.97 (s, 1 H, 10), 5.46 (s, 1 H, 5), 7.19 (d, ³J_{H,H} = 8.4, 2 H, 20), 7.41 (d, ³J_{H,H} = 8.4, 2 H, 21). – **¹³C-NMR** (150 MHz, HSQC, HMBC, CDCl₃): 15.6 (+, 1 C, 23), 21.0 (+, 1 C, 25), 22.0 (+, 1 C, 25), 22.7 (-, 1 C, 17), 25.2 (+, 1 C, 24), 28.3 (+, 3 C, 1), 31.1 (+, 1 C, 15), 33.9 (-, 1 C, 16), 35.8 (-, 1 C, 7), 39.7 (-, 1 C, 14), 46.6 (+, 1 C, 18), 67.7 (-, 1 C, 8), 69.7 (C_{quat}, 1 C, 6), 76.3 (+, 1 C, 13), 80.5 (C_{quat}, 1 C, 3), 85.2 (+, 1 C, 10), 122.1 (C_{quat}, 1 C, 22), 128.1 (+, 2 C, 20), 131.3 (+, 2 C, 21), 136.2 (C_{quat}, 1 C, 19), 154.3 (C_{quat}, 1 C, 4), 170.3 (C_{quat}, 1 C, 11). – **MS** (ES, DCM/MeOH + 10 mmol/l NH₄OAc): *m/z* (%) = 524.3 (29) [MH⁺], 543.4 (100) [M + NH₄⁺], 524.4 (100) [M – H⁺], 582.4 (81) [M + CH₃COO]. – **IR** (NEAT) [cm^{-1}]: $\tilde{\nu}$ = 2956, 2927, 2869, 1708, 1591, 1487, 1367, 1247, 1160, 1011, 1070, 1011, 847, 757. – **MF** C₂₆H₃₈BrNO₅. – **MW** 524.49.

X-Ray structure and crystal data of **144**:

Monoclinic; space group: P 2₁; cell dimensions: a = 10.8591(2) Å, α = 90°, b = 5.9417(1) Å, β = 93.6936(18)°, c = 20.7199(5) Å, γ = 90°; V = 1334.10(5) Å³; Z = 2, D_x = 1.306 Mg/m³; μ = 2.377 mm⁻¹; F(000) = 552. Data collection: T = 123 K; graphite monochromator. A translucent colorless crystal with dimensions of 0.200 x 0.060 x 0.010 mm was used to measure 6636 reflections (3517 unique reflections, R_{int} = 0.0386) from 3.32° to 62.28° on a Oxford Diffraction Gemini Ultra diffractometer with the omega-scan method. Structure refinement: The F² value was refined using the full-matrix least squares refinement method, with a goodness-of-fit of 0.888 for all reflections and 304 parameters.

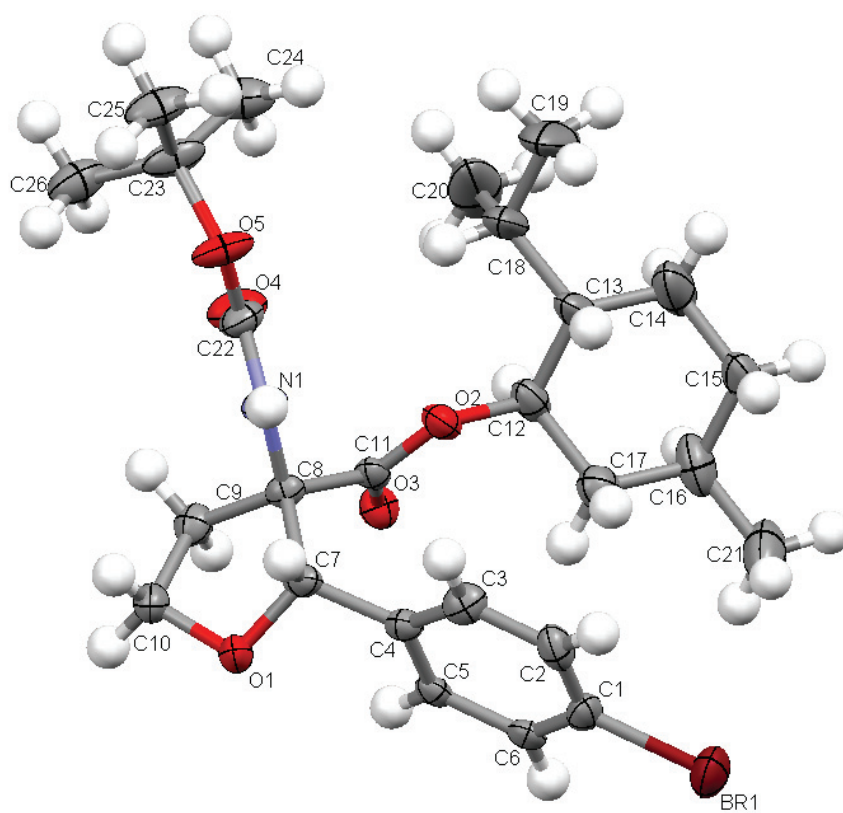

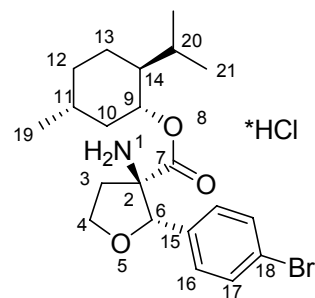

(2S,3R)-2-(4-Bromophenyl)-3-(((1R,2S,5R)-2-isopropyl-5-methylcyclohexyloxy)carbonyl)-tetrahydrofuran-3-aminium chloride (**145**):

Compound **144** (50 mg, 0.10 mmol) was dissolved under ice bath cooling at 0 °C in diethyl ether. To this solution 0.7 ml ice cold HCl saturated ether (7 ml/mmol Boc) was added and the mixture was stirred over night at room temperature. The solvent was removed under reduced pressure to give the HCl salt of the product as white hygroscopic solid in quantitative yield (44 mg, 0.10 mmol). No further purification was necessary.

MP >180 °C. – ¹³**C-NMR** (75 MHz, CDCl₃): δ = 14.7 (+, 1 C, 19), 19.8 (+, 1 C, 21), 20.8 (+, 1 C, 21), 21.7 (-, 1 C, 13), 24.7 (+, 1 C, 20), 30.0 (+, 1 C, 11), 32.7 (-, 1 C, 12), 35.4 (-, 1 C, 3), 38.2 (-, 1 C, 10), 45.1 (+, 1 C, 14), 66.5 (-, 1 C, 4), 67.9 (C_{quat}, 1 C, 2), 76.9 (+, 1 C, 9), 85.1 (+, 1 C, 6), 121.7 (C_{quat}, 1 C, 18), 127.5 (+, 2 C, CH-Ar), 130.4 (+, 2 C, CH-Ar), 133.3 (C_{quat}, 1 C, 15), 166.5 (C_{quat}, 1 C, 7). – **MS** (ES, DCM/MeOH + 10 mmol/l NH₄OAc): m/z (%) = 424.2 (100) [MH⁺]. – **IR** (NEAT) [cm⁻¹]: $\tilde{\nu}$ = 2954, 2929, 2870, 1707, 1592, 1489, 1366, 1242, 1161, 1010, 1071, 1009, 847, 758. – **MF** C₂₁H₃₀BrNO₃ · HCl. – **MW** 460.84.

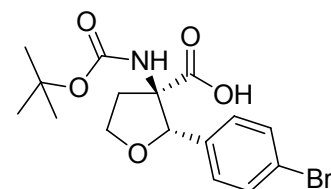

(2S,3R)-2-(4-Bromophenyl)-3-(tert-butoxycarbonylamino)-tetrahydrofuran-3-carboxylic acid (146):

Boc-TAA-Omenthol **144** (200 mg, 0.38 mmol) was dissolved in 3.8 ml of methanol (10 ml/mmol). To the solution a 1 ml water (2.5 ml/mmol) and powdered KOH (171 mg, 3.05 mmol, 8 eq) were added and the mixture was stirred at 110 °C for 3 hours in a laboratory microwave. The mixture was quenched with water (12 ml/mmol) and the methanol was removed under reduced pressure. The resulting slurry was extracted with diethyl ether (2x5 ml) and the organic phases were discarded. The aqueous phase was acidified with 1M aqueous KHSO₄-solution and extracted with dichloromethane (3x10 ml). The combined organic layers were dried over MgSO₄ and the solvent was removed under reduced pressure to give the product as colorless solid in 55 % yield (80 mg, 0.21 mmol).

MP 98-100 °C. – **¹H-NMR** (300 MHz, MeCN-*d*₃): δ = 1.39 (s, 9 H, Boc-CH₃), 2.25-2.41 (m, 1 H, CH₂), 2.68-2.82 (m, 1 H, CH₂), 3.92-4.03 (m, 1 H, OCH₂), 4.25 (dt, ³J_{H,H} = 3.4, ³J_{H,H} = 8.3, 1 H, OCH₂), 4.84 (bs, 1 H, CH), 7.22 (d, ³J_{H,H} = 8.5, 2 H, CH-Ar), 7.44 (d, ³J_{H,H} = 8.5, 2 H, CH-Ar). – **¹³C-NMR** (75 MHz, MeCN-*d*₃): δ = 27.2 (+, 3 C, Boc-CH₃), 35.1 (-, 1 C, CH₂), 67.2 (-, 1 C, OCH₂), 70.0 (C_{quat}, 1 C, CNH), 83.7 (C_{quat}, 1 C, C(CH₃)₃), 85.1 (+, 1 C, CH), 121.2 (C_{quat}, 1 C, C-Br), 128.3 (+, 2 C, CH-Ar), 130.6 (+, 2 C, CH-Ar), 136.9 (C_{quat}, 1 C, C-Ar), 154.8 (C_{quat}, 1 C, Boc-CO), 171.1 (C_{quat}, 1 C, COOH). – **MS** (CI, NH₃): *m/z* (%) = 269.1 (29) [MNH₄⁺ - C₄H₈, Br vs. H], 325.1 (46) [MNH₄⁺, Br vs. H], 348.9 (45) [MNH₄⁺ - C₄H₈], 386.0 (5) [MH⁺], 403.0 (100) [MNH₄⁺]. – **IR** (NEAT) [cm⁻¹]: $\tilde{\nu}$ = 3248, 3131, 2965, 2926, 2860, 1737, 1693, 1366, 1247, 1224, 1160, 1107, 1066, 1009, 992, 938, 839, 790, 698. – **MF** C₁₆H₂₀BrNO₅. – **MW** 386.24.

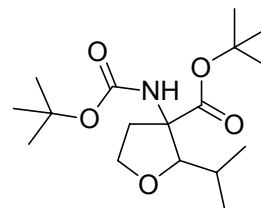

tert-Butyl 3-(tert-butoxycarbonylamino)-2-isopropyl-tetrahydrofuran-3-carboxylate (157):

The synthesis followed **GP 1** using (3-(tert-butoxycarbonylamino)-4-tert-butoxy-4-oxobutyl)-dimethylsulfonium iodide **133** (1.25 g, 2.79 mmol, 1.5 eq.), cesium hydroxide (418 mg, 2.79 mmol, 1.5 eq.) and isobutyraldehyde **150** (169 μ l, 1.86 mmol, 1 eq.). The product was purified with a 85:15 mixture of PE:diethyl ether ($R_f = 0.2$) to give **157** as a colorless oil in 2 % yield (18 mg, 0.05 mmol). The product was obtained as an inseparable mixture of the cis and trans product with a cis:trans ratio of 1:9.

¹H-NMR (300 MHz, CDCl₃): δ = 0.90-0.92 (m, 6 H, CH₃), 1.41-1.52 (m, 18 H, tBu-CH₃), 1.69-1.80 (m, 1 H, CH), 2.42 (bs, 1 H, CH₂), 2.62-2.79 (m, 1 H, CH₂), 3.45-3.55 (m, 1 H, CH₂), 3.88-4.11 (m, 2 H, CH₂ + CH), 5.02 (bs, 0.1 H, cisNH), 5.28 (bs, 0.9 H, trans-NH). – **¹³C-NMR** (75 MHz, CDCl₃): δ = 16.7 (+, 0.1 C, cis-CH₃), 17.2 (+, 0.9 C, trans-CH₃), 18.5 (+, 0.1 C, cis-CH₃), 19.1 (+, 0.9 C, trans-CH₃), 20.4 (+, 0.1 C, cis-CH), 20.8 (+, 0.9 C, trans-CH), 27.9 (+, 3 C, tBu-CH₃), 28.4 (+, 3 C, tBu-CH₃), 32.6 (-, 1 C, CH₂), 66.5 (-, 0.1 C, cis-OCH₂), 66.6 (-, 0.9 C, trans-OCH₂), 67.6 (C_{quat}, 1 C, NHC), 82.3 (C_{quat}, 2 C, tBu-C), 87.5 (+, 1 C, CH), 154.0 (C_{quat}, 0.1 C, cis-NHCO), 154.4 (C_{quat}, 0.9 C, trans-NHCO), 171.2 (C_{quat}, 0.1 C, cis-COO), 171.3 (C_{quat}, 0.9 C, trans-COO). – **MS** (Cl, NH₃): m/z (%) = 218.2 (9) [MH⁺ - 2 C₄H₈], 274.2 (51) [MH⁺ - C₄H₈], 330.2 (100) [MH⁺]. – **HR-MS** (FAB, MeOH/glycerol): [MH⁺] calcd. for C₁₇H₃₂NO₅ 330.2280; found 330.2288. – **IR** (neat) [cm⁻¹]: $\tilde{\nu}$ = 2977, 2877, 2361, 1708, 1492, 1392, 1366, 1250, 1157, 1085, 1052, 940, 848. – **MF** C₁₇H₃₁NO₅. – **MW** 329.43.

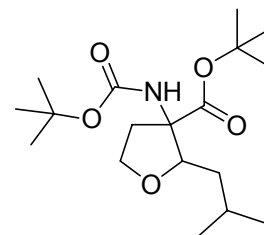

tert-Butyl 3-(tert-butoxycarbonylamino)-2-isobutyl-tetrahydrofuran-3-carboxylate (158):

The synthesis followed **GP 1** using (3-(tert-butoxycarbonylamino)-4-tert-butoxy-4-oxobutyl)-dimethylsulfonium iodide **133** (1.25 g, 2.79 mmol, 1.5 eq.), cesium hydroxide (418 mg, 2.79 mmol, 1.5 eq.) and 3-methylbutanal **151** (201 μ l, 1.86 mmol, 1 eq.). The product was purified with a 85:15 mixture of PE:diethyl ether ($R_f = 0.16$) to give **158** as a colorless oil in 17 % yield (106 mg, 0.18 mmol). The product was obtained as an inseparable mixture of the cis and trans product with a cis:trans ratio of 1:5.

¹H-NMR (300 MHz, CDCl₃): $\delta = 0.87$ -0.90 (m, 6 H, CH₃), 1.30-1.41 (m, 2 H, CH₂), 1.44-1.47 (m, 18 H, tBu-CH₃), 1.71-1.80 (m, 1 H, CH), 2.37 (bs, 1 H, CH₂), 2.65-2.85 (m, 1 H, CH₂), 3.76-4.08 (m, 3 H, CH₂ + CH), 4.93 (bs, 0.2 H, cis-NH), 5.12 (bs, 0.8 H, trans-NH). – **¹³C-NMR** (75 MHz, CDCl₃): $\delta = 21.6$ (+, 0.8 C, trans-CH₃), 21.9 (+, 0.2 C, cis-CH₃), 23.6 (+, 0.8 C, trans-CH₃), 23.7 (+, 0.2 C, cis-CH₃), 25.2 (+, 0.8 C, trans-CH), 25.7 (+, 0.2 C, cis-CH), 27.9 (+, 3 C, tBu-CH₃), 28.3 (+, 3 C, tBu-CH₃), 38.0 (-, 0.2 C, cis-CH₂), 39.3 (-, 0.8, trans-CH₂), 66.3 (-, 0.2 C, cis-OCH₂), 66.9 (-, 0.8 C, trans-OCH₂), 67.6 (C_{quat}, 0.2 C, cis-NHC), 68.2 (C_{quat}, 0.8 C, trans-NHC), 79.8 (C_{quat}, 1 C, tBu-C), 81.7 (C_{quat}, 0.2 C, cis-tBu-C), 82.0 (C_{quat}, 0.8 C, trans-tBu-C), 82.1 (+, 0.8 C, trans-CH), 82.8 (+, 0.2 C, cis-CH), 154.7 (C_{quat}, 0.8 C, trans-NHCO), 155.1 (C_{quat}, 0.2 C, cis-NHCO), 170.6 (C_{quat}, 0.2 C, cis-COO), 170.7 (C_{quat}, 0.8 C, trans-COO). – **MS** (CI, NH₃): m/z (%) = 244.2 (25) [MH⁺ - Boc], 288.2 (44) [MH⁺ - C₄H₈], 305.2 (19) [MNH₄⁺ - C₄H₈], 344.3 (100) [MH⁺]. – **HR-MS** (FAB, MeOH/glycerol): [M⁺] calcd. for C₁₈H₃₃NO₅ 343.2359; found 343.2358. – **IR** (neat) [cm⁻¹]: $\tilde{\nu} = 3326, 2957, 2359, 1708, 1497, 1366, 1250, 1160, 1116, 1098, 1055, 885, 849, 781$. – **MF** C₁₈H₃₃NO₅. – **MW** 343.46.

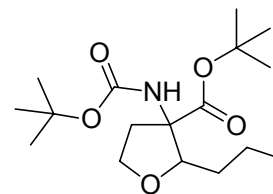

tert-Butyl 3-(tert-butoxycarbonylamino)-2-propyl-tetrahydrofuran-3-carboxylate (159):

The synthesis followed **GP 1** using (3-(tert-butoxycarbonylamino)-4-tert-butoxy-4-oxobutyl)-dimethylsulfonium iodide **133** (480 mg, 0.75 mmol, 1.5 eq.), cesium hydroxide (112 mg, 0.75 mmol, 1.5 eq.) and butyraldehyde **147** (44 μ l, 0.5 mmol, 1 eq.). The product was purified with a 85:15 mixture of PE:diethyl ether (R_f = 0.21) to give **159** as a colorless oil in 36 % yield (60 mg, 0.18 mmol). The product was obtained as an inseparable mixture of the cis and trans product with a cis:trans ratio of 1:3.

¹H-NMR (300 MHz, CDCl₃): δ = 0.86 (q, ³J_{H,H} = 8.2, 3 H, CH₃), 1.21-1.55 (m, 22 H, tBu-CH₃ + CH₂), 2.29 (bs, 1 H, CH₂), 2.61-2.79 (m, 1 H, CH₂), 3.62-4.15 (m, 3 H, CH₂ + CH), 4.91 (bs, 0.25 H, cis-NH), 5.01 (bs, 0.75 H, trans-NH). – **¹³C-NMR** (75 MHz, CDCl₃): δ = 14.0 (+, 0.75 C, trans-CH₃), 14.1 (+, 0.25 C, cis-CH₃), 19.8 (-, 0.75 C, trans-CH₂), 20.0 (-, 0.25 C, cis-CH₂), 27.9 (+, 3 C, tBu-CH₃), 28.3 (+, 3 C, tBu-CH₃), 31.3 (-, 0.25 C, cis-CH₂), 32.7 (-, 0.75 C, trans-CH₂), 35.6 (-, 0.25, cis-CH₂), 37.2 (-, 0.75 C, trans-CH₂), 66.2 (-, 0.25 C, cis-OCH₂), 66.8 (-, 0.75 C, trans-OCH₂), 67.3 (C_{quat}, 0.25 C, cis-NHC), 68.2 (C_{quat}, 0.75 C, trans-NHC), 79.8 (C_{quat}, 1 C, tBu-C), 81.7 (C_{quat}, 0.25 C, cis-tBu-C), 82.0 (C_{quat}, 0.75 C, trans-tBu-C), 84.1 (+, 0.75 C, trans-CH), 84.5 (+, 0.25 C, cis-CH), 154.8 (C_{quat}, 0.25 C, cis-NHCO), 155.1 (C_{quat}, 0.75 C, trans-NHCO), 170.6 (C_{quat}, 0.75 C, trans-COO), 170.7 (C_{quat}, 0.25 C, cis-COO). – **MS** (CI, NH₃): m/z (%) = 230.2 (18) [MH⁺ - Boc], 274.2 (30) [MH⁺ - C₄H₈], 291.2 (19) [MNH₄⁺ - C₄H₈], 330.2 (100) [MH⁺], 676.6 (9) [2 M + NH₄⁺]. – **HR-MS** (FAB, MeOH/glycerol): [M⁺] calcd. for C₁₇H₃₁NO₅ 329.2202; found 329.2210. – **IR** (neat) [cm⁻¹]: $\tilde{\nu}$ = 3334, 2975, 2357, 1709, 1490, 1366, 1250, 1157, 1077, 949, 848. – **MF** C₁₇H₃₁NO₅. – **MW** 329.43.

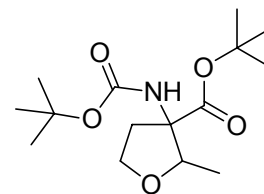

tert-Butyl 3-(tert-butoxycarbonylamino)-2-methyl-tetrahydrofuran-3-carboxylate (160):

The synthesis followed **GP 1** using (3-(tert-butoxycarbonylamino)-4-tert-butoxy-4-oxobutyl)-dimethylsulfonium iodide **133** (670 mg, 1.50 mmol, 1.2 eq.), cesium hydroxide (225 mg, 1.50 mmol, 1.2 eq.) and acetaldehyde **152** (70 μ l, 1.25 mmol, 1 eq.). The product was purified with a 80:20 mixture of PE:diethyl ether ($R_f = 0.1$) to give **160** as a colorless oil in 28 % yield (105 mg, 0.93 mmol). The product was obtained as an inseparable mixture of the cis and trans product with a cis:trans ratio of 1:2.

MP 70 °C. – **¹H-NMR** (300 MHz, CDCl₃): δ = 1.16 (d, ³J_{H,H} = 6.3, 2 H, trans-CH₃), 1.23 (d, ³J_{H,H} = 6.3, 1 H, cis-CH₃), 1.44 (s, 9 H, tBu-CH₃), 1.47 (s, 9 H, tBu-CH₃), 2.21-2.40 (m, 1 H, CH₂), 2.67-2.82 (m, 1 H, CH₂), 3.78-3.99 (m, 2.33 H, CH₂ + cis-CH), 4.06 (dt, ³J_{H,H} = 4.1, ³J_{H,H} = 8.5, 0.66 H, trans-CH), 4.94 (bs, 0.34 H, cis-NH), 5.13 (bs, 0.66, trans-NH). – **¹³C-NMR** (75 MHz, CDCl₃): δ = 13.3 (+, 0.33 C, cis-CH₃), 15.2 (+, 0.66 C, trans-CH₃), 26.9 (+, 2 C, trans-tBu-CH₃), 26.9 (+, 1 C, cis-tBu-CH₃), 27.3 (+, 2 C, trans-tBu-CH₃), 27.3 (+, 1 C, cis-tBu-CH₃), 34.1 (-, 0.66 C, trans-CH₂), 36.1 (-, 0.33 C, cis-CH₂), 65.1 (-, 0.33 C, cis-OCH₂), 65.8 (-, 0.66 C, trans-OCH₂), 66.2 (C_{quat}, 0.33 C, cis-NHC), 67.5 (C_{quat}, 0.66 C, trans-NHC), 78.9 (C_{quat}, 1 C, tBu-C), 79.9 (C_{quat}, 1 C, tBu-C), 80.7 (+, 0.33 C, cis-CH), 81.0 (+, 0.66 C, trans-CH), 153.8 (C_{quat}, 0.66 C, trans-NHCO), 154.1 (C_{quat}, 0.33 C, cis-NHCO), 169.4 (C_{quat}, 0.66 C, COO), 169.6 (C_{quat}, 0.33 C, COO). – **MS** (CI, NH₃): m/z (%) = 202.1 (25) [MH⁺ - Boc], 246.1 (40) [MH⁺ - C₄H₈], 263.1 (34) [MNH₄⁺ - C₄H₈], 302.1 (100) [MH⁺], 319.1 (4) [MNH₄⁺]. – **HR-MS** (FAB, MeOH/DCM/NBA): [MH⁺] calcd. for C₁₅H₂₈NO₅ 302.1967; found 302.1966. – **IR** (neat) [cm⁻¹]: $\tilde{\nu}$ = 2973, 2361, 1705, 1489, 1369, 1247, 1158, 1073, 955, 849. – **MF** C₁₅H₂₇NO₅. – **MW** 301.38.

X-Ray structure and crystal data of *trans*-**160**:

Orthorhombic; space group: $Pn\bar{a}2_1$; cell dimensions: $a = 10.1882(3)$ Å, $\alpha = 90^\circ$, $b = 10.6160(4)$ Å, $\beta = 90^\circ$, $c = 16.3593(5)$ Å, $\gamma = 90^\circ$; $V = 1769.39(10)$ Å³; $Z = 4$, $D_x = 1.128$ Mg/m³; $\mu = 0.691$ mm⁻¹; $F(000) = 652$. Data collection: $T = 123$ K; graphite monochromator. A translucent colorless crystal with dimensions of $0.500 \times 0.080 \times 0.020$ mm was used to measure 4695 reflections (2087 unique reflections, $R_{\text{int}} = 0.0251$) from 4.97° to 66.69° on a Oxford Diffraction Gemini Ultra diffractometer with the omega-scan method. Structure refinement: The F^2 value was refined using the full-matrix least squares refinement method, with a goodness-of-fit of 1.070 for all reflections and 194 parameters.

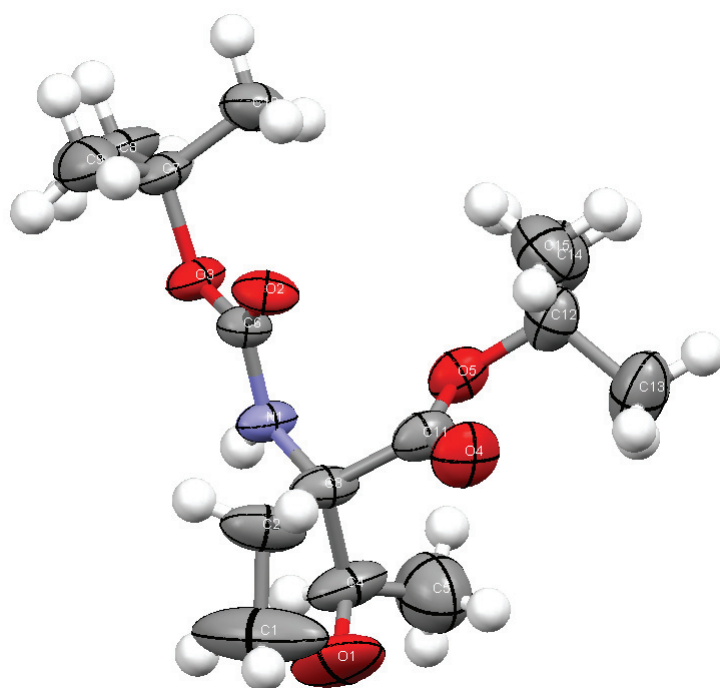

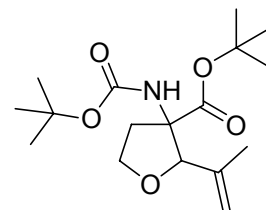

tert-Butyl 3-(tert-butoxycarbonylamino)-2-(prop-1-en-2-yl)-tetrahydrofuran-3-carboxylate
(161):

The synthesis followed **GP 1** using (3-(tert-butoxycarbonylamino)-4-tert-butoxy-4-oxobutyl)-dimethylsulfonium iodide **133** (2.39 g, 5.35 mmol, 1.5 eq.), cesium hydroxide (802 mg, 5.35 mmol, 1.5 eq.) and methacrylaldehyde **153** (294 μ l, 3.57 mmol, 1 eq.). The product was purified with a 80:20 mixture of PE:diethyl ether (R_f = 0.22) to give **161** as a colorless oil in 18 % yield (210 mg, 0.64 mmol).

¹H-NMR (300 MHz, CDCl₃): δ = 1.37 (s, 9 H, tBu-CH₃), 1.40 (s, 9 H, tBu-CH₃), 1.69 (s, 3 H, CH₃), 2.35-2.53 (m, 1 H, CH₂), 2.57-2.71 (m, 1 H, CH₂), 4.00 (q, ³J_{H,H} = 8.1, 1 H, OCH₂), 4.12 (dt, ³J_{H,H} = 4.5, ³J_{H,H} = 8.4, 1 H, OCH₂), 4.31 (s, 1 H, CH), 4.86 (s, 1 H, =CH₂), 5.04 (s, 1 H, =CH₂), 5.32 (bs, 1 H, NH). – **¹³C-NMR** (75 MHz, CDCl₃): δ = 18.5 (+, 1 C, CH₃), 26.8 (+, 3 C, tBu-CH₃), 27.3 (+, 3 C, tBu-CH₃), 34.8 (-, 1 C, CH₂), 66.4 (C_{quat}, 1 C, NHC), 67.5 (-, 1 C, OCH₂), 81.2 (C_{quat}, 2 C, tBu-C), 85.5 (+, 1 C, CH), 112.2 (-, 1 C, =CH₂), 139.7 (C_{quat}, 1 C, C=), 153.4 (C_{quat}, 1 C, NHCO), 169.4 (C_{quat}, 1 C, COO). – **MS** (CI, NH₃): m/z (%) = 228.1 (28) [MH⁺ - Boc], 272.1 (41) [MH⁺ - C₄H₈], 289.1 (50) [MNH₄⁺ - C₄H₈], 328.1 (100) [MH⁺], 345.1 (8) [MNH₄⁺]. – **HR-MS** (FAB, MeOH/glycerol): [M⁺] calcd. for C₁₇H₂₉NO₅ 327.2046; found 327.2043. – **IR** (neat) [cm⁻¹]: $\tilde{\nu}$ = 3409, 3059, 2063, 1614, 1483, 1335, 1242, 1133, 1098, 1055, 887, 823, 708. – **MF** C₁₇H₂₉NO₅. – **MW** 327.42.

3. Stable Right- and Left-handed Peptide Helices

3.1. Introduction

The *de novo* design of peptides and peptidomimetics with a defined and predictable 3-dimensional structure^{219, 220} has received considerable interest from chemists and biologists in recent years. Short peptide sequences consisting only of natural α -amino acids typically show flexible structures. In contrast, stable structures in solution can be accomplished by replacing natural amino acids by non-proteinogenic analogues which may induce a defined secondary structure even in short peptides.²²¹ Such amino acid mimetics attracted much attention in the last years because of their potential use as peptide models, biological probes, drug candidates or catalysts.²²² Their often more rigid structure leads to conformational constraints that might lock the peptide in its bioactive or catalytically active conformation.²²³ An additional advantage can be an increase of the peptides metabolic stability after incorporation of amino acid mimetics.²²⁴ One very successful way among others^{143a} to increase peptide backbone rigidity is the use of C $^{\alpha}$ -tetrasubstituted α -amino acids (TAAs).²²⁵ α -Aminoisobutyric acid (Aib), which also occurs in natural peptide sequences of peptaibiotics or peptaibols,^{185, 186, 187} is the most extensively investigated compound of this kind. The helical tendencies of Aib containing peptides are well characterized, showing that short strands form a stable 3_{10} -helix while longer helices emerge into mixed $3_{10}/\alpha$ -helices or pure α -helices.^{212a} Cycloaliphatic C $^{\alpha}$ -tetrasubstituted α -amino acids Ac $_n$ c ($n = 3-9$)²²⁶ with varying ring sizes are also well studied.²²⁷ However, the lack of a C $^{\alpha}$ -stereocenter and of a side-chain functional group for further derivatization is a drawback of these compounds. Therefore the synthesis of cyclic C $^{\alpha}$ -tetrasubstituted α -amino acids which show at least one stereocenter²²⁸ and have an additional functional group in their side chain was investigated in recent years,²¹⁶ but only very few examples of successful incorporation into peptide chains have been reported.²²⁹ Our group has recently introduced the C $^{\alpha}$ -tetrasubstituted tetrahydrofuran amino acid *rac*-**137** which has two stereocenters at the quaternary C $^{\alpha}$ - and at the C $^{\beta}$ -atom. The brominated arene substituent allows further functionalization by standard Pd(0)- or Cu(I)-catalysis.²³⁰ When inserted into small tripeptides, the molecule induces stable secondary structures in solution by the formation of β -turns.²¹⁸

In the following the extension of this concept by incorporating the unnatural amino acid into longer peptide chains to form stable helices as structurally predictable and tunable scaffolds for peptidomimetics is reported.

3.2. Synthesis of the Peptides

In a first approach to the synthesis of C^α-tetrasubstituted tetrahydrofuran amino acid containing peptides it was decided to try a direct coupling of two TAAs with each other. To obtain a stereochemically pure peptide, the previously synthesized building blocks **145** and **146** were used. As coupling reagents, the very reactive combination of HATU and HOAt was used but no product was formed.

Scheme 21: Peptide coupling reaction of the enantiomerically pure amino acids **145** and **146**.

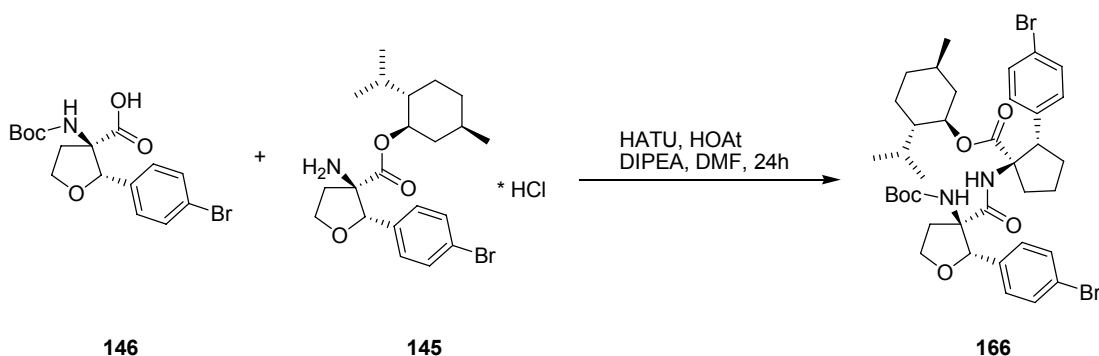

The reason for this seems to be the high sterical demand of the unnatural amino acids themselves which, in this special case, is further increased by the large ester functionality. Furthermore, the synthesis of peptides with numerous C^α-tetrasubstituted amino acids is a rather challenging task due to their relatively low reactivity in amide bond formation.²³¹ To overcome these difficulties it was decided to reduce the sterical demand by the use of natural amino acids in combination with the unnatural ones, leading to an alternating peptide sequence of natural and unnatural amino acids.

As natural amino acids to be used in combination with the unnatural TAA *rac*-**138**, *S*- and *R*-valine were chosen. Reasons for the use of valine are the absence of a side chain functionality which could lead to side reactions and also the absence of a side chain stereo center. Another criterion was the sterical demand of the side chain which on the one hand should be larger than the one of an alanine to help inducing a stable secondary structure but on the other hand should not lower the reactivity too much.

Therefore, the isomeric di-, tetra- and hexapeptides and one octapeptide shown in Figure 74 were synthesized and their structure was analyzed in solid state and in solution.

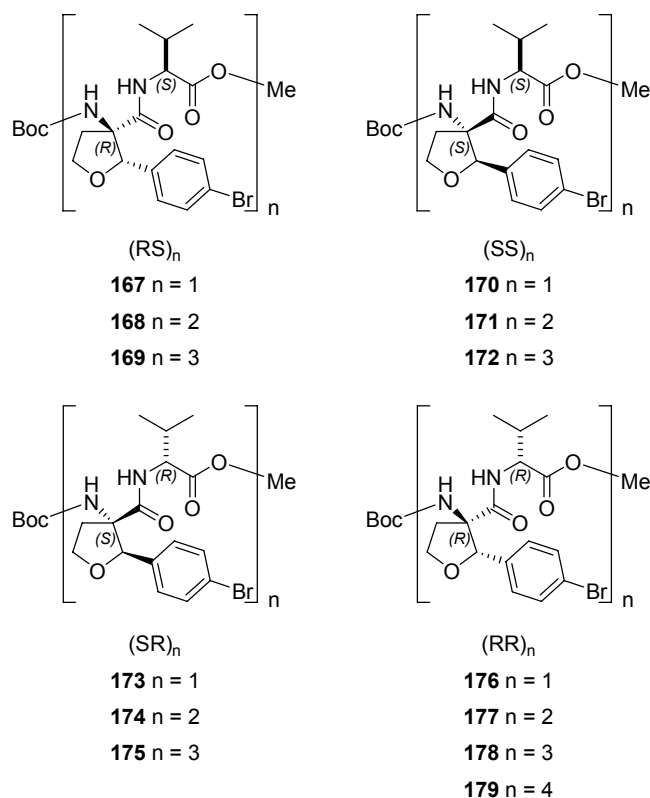
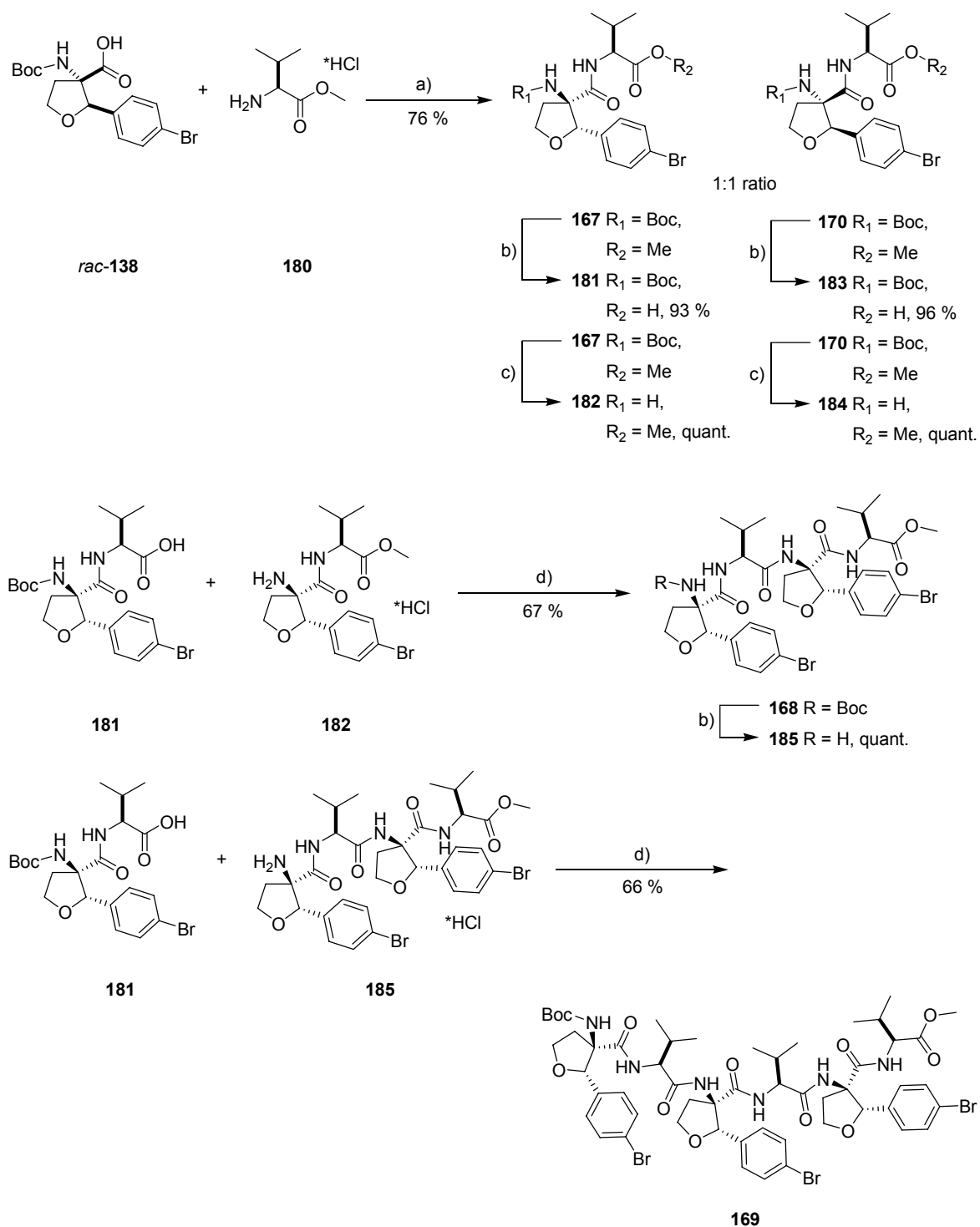

Figure 74: TAA-containing isomeric di-, tetra-, hexa- and octapeptides prepared and investigated in this study.

3.2.1. Synthesis of Peptides Containing S-Valine

The target peptides were prepared by a combination of protecting and deprotecting steps together with standard solution phase peptide coupling chemistry. The synthesis is shown in Scheme 22 and starts from *N*-terminally Boc-protected racemic tetrahydrofuran amino acid Boc-TAA-OH *rac*-**138**.²¹⁸ The compound was coupled with H-S-Val-OMe·HCl **180** using EDC/HOBt to give the dipeptides (RS) **167** and (SS) **170**. Two diastereomers emerged from the coupling reaction, which were separated by column chromatography. The isolated dipeptides **167** and **170** were then used separately in the next steps to yield enantiomerically pure tetrapeptides. To achieve this, two equimolar amounts of compound **167** were deprotected either *C*-terminal with 1M aqueous LiOH to give free acid **181**, or *N*-terminal with HCl saturated diethyl ether cleaving the Boc protecting group. Carboxylic acid **181** and amine **182** were coupled using HATU/HOAt to give tetrapeptide (RS)₂ **168** in 67 % yield. The tetrapeptide (SS)₂ **171** was obtained analogously in comparable yield. Compound (RS)₂ **168** was Boc deprotected and subsequently coupled with dipeptide acid **181** to give hexapeptide (RS)₃ **169**. The same procedure was used to synthesize the hexapeptide **172** (SS)₃.

Scheme 22: Synthesis pathway leading to the *S*-valine containing peptides **167** - **172**. a) DIPEA, EDC, HOBt, dry DMF, 24h, rt; b) LiOH, water/THF, 24h, rt; c) HCl sat. diethyl ether, DCM, 24h, rt; d) DIPEA, HATU, HOAt, dry DMF, 24h, rt.



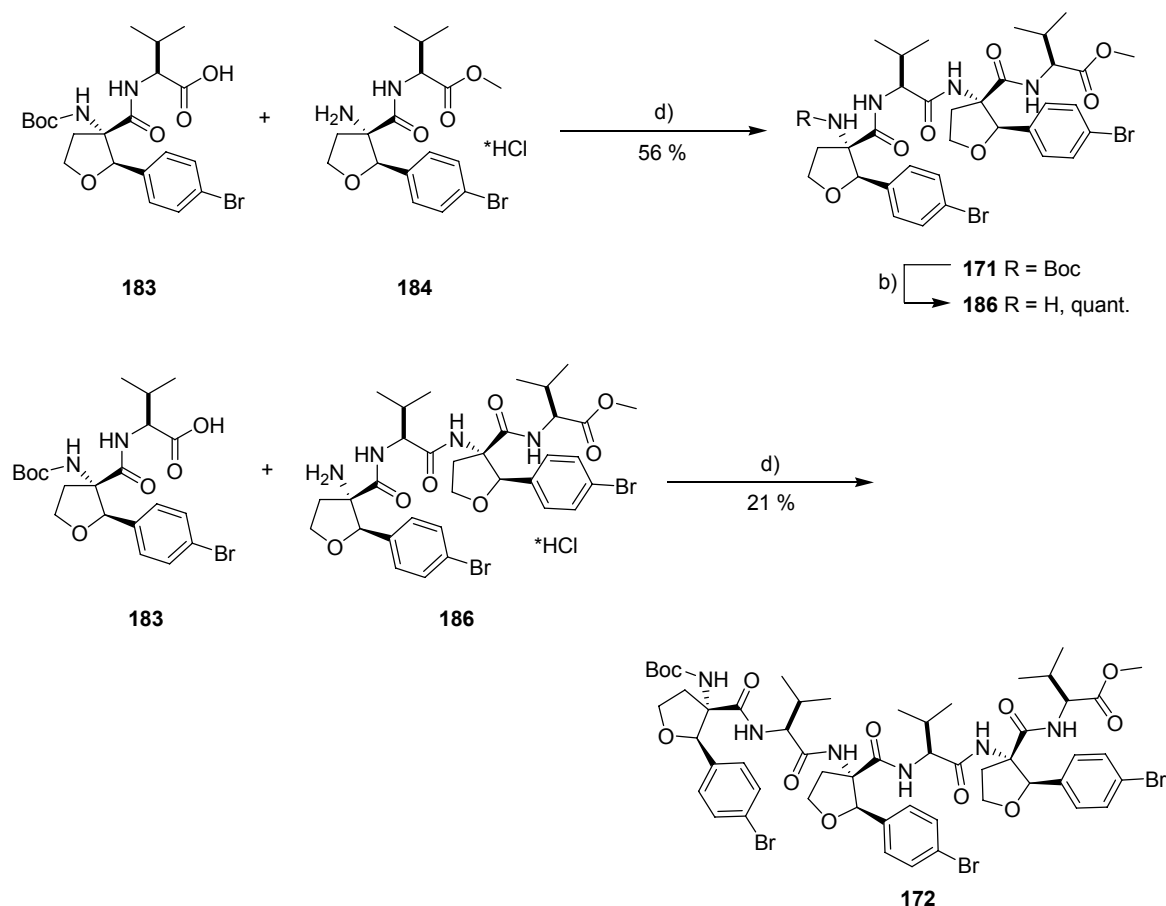

3.2.2. Synthesis of Peptides Containing *R*-Valine

In analogy to the synthesis of the *S*-valine containing peptides, the peptides with *R*-valine were also synthesized. By this method it was possible to synthesize peptides which are enantiomeric to their *S*-valine counterparts. This should lead to a enantiomeric secondary structure, meaning that a helix formed of *R*-valine amino acids should have an opposite handedness as the one containing *S*-valine.

The first step of the synthesis was again the coupling of the racemic Boc-TAA-OH *rac*-**138** with the methyl ester of *R*-valine **187**. The synthesis gave the two diastereomeric products (SR) **173** and (RR) **176** in an excellent yield of 83 %. After separation by column chromatography and deprotection using HCl saturated diethyl ether for the Boc-group and LiOH for the ester functionality, the resulting building blocks (SR) **188**, **189** and (RR) **190**, **191** were used for the synthesis of the tetrapeptides **174** and **177**. The tetrapeptide (RR)₂ **177**, which is all *R*-configured in the backbone and the diastereomer (SR)₂ **174** were obtained in good yields of 58 % for the former and 55 % for the latter. After removal of the Boc-group with HCl saturated diethyl ether both amines (SR)₂ **192** and (RR)₂ **193** were used for the synthesis of the hexapeptides (SR)₃ **175** and (RR)₃ **178**. As the peptide (RR)₃ **178** was formed in reasonable yields, it was decided to synthesize an octapeptide using

the hexapeptide as starting material. The octapeptide (RR)₄ **179** was synthesized by the use of the Boc-protected hexapeptide (RR)₃ **194** together with the dipeptide free acid (RR) **190**. The peptide (RR)₄ **179** was formed in a yield of 28 %.

Scheme 23: Synthesis pathway leading to the *R*-valine containing peptides **173** – **176**. a) DIPEA, EDC, HOBT, dry DMF, 24h, rt; b) LiOH, water/THF, 24h, rt; c) HCl sat. diethyl ether, DCM, 24h, rt; d) DIPEA, HATU, HOAt, dry DMF, 24h, rt.

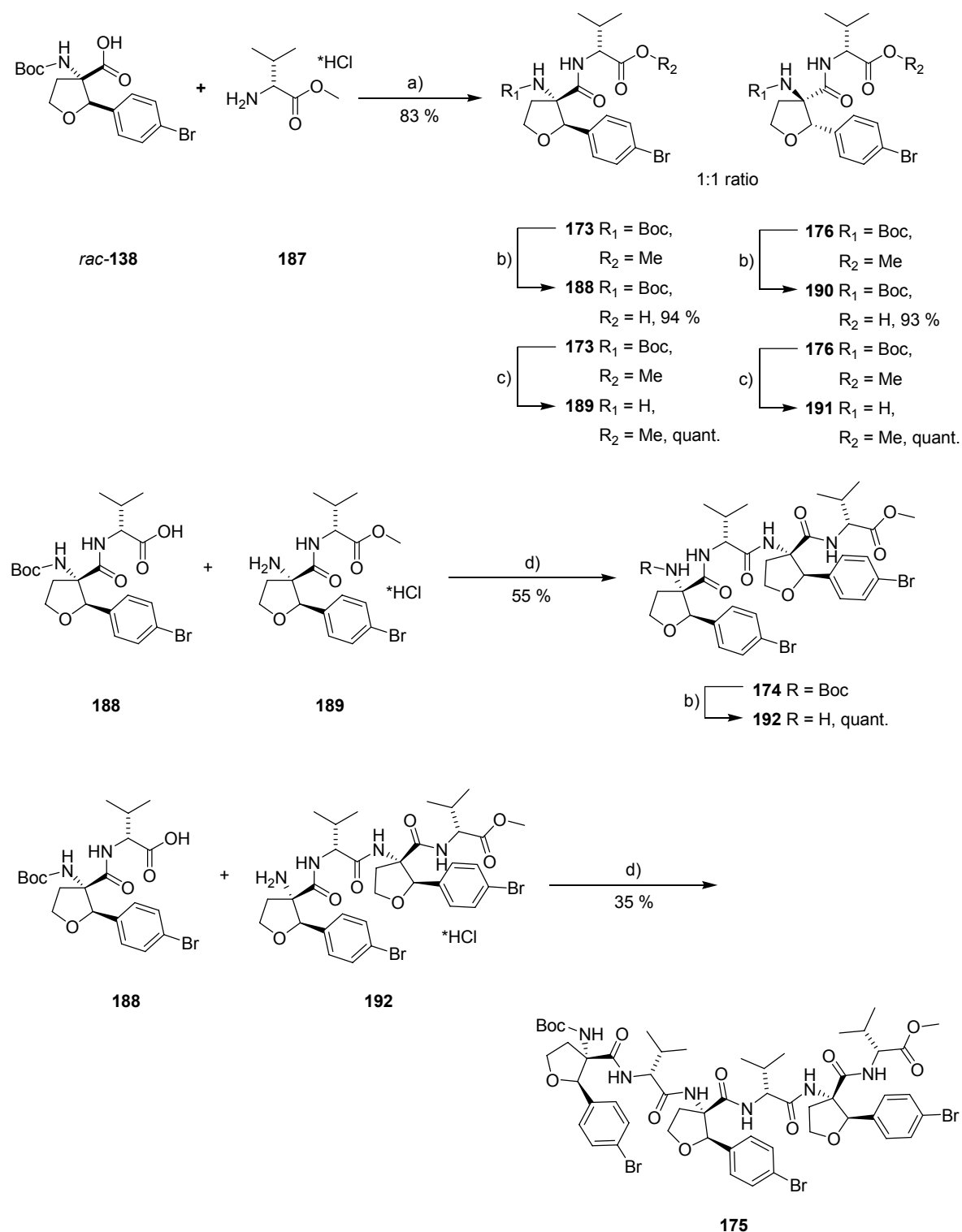

Scheme 24: Synthesis pathway leading to the *R*-valine containing peptides **177** – **179**. a) DIPEA, EDC, HOBt, dry DMF, 24h, rt; b) LiOH, water/THF, 24h, rt; c) HCl sat. diethyl ether, DCM, 24h, rt; d) DIPEA, HATU, HOAt, dry DMF, 24h, rt.

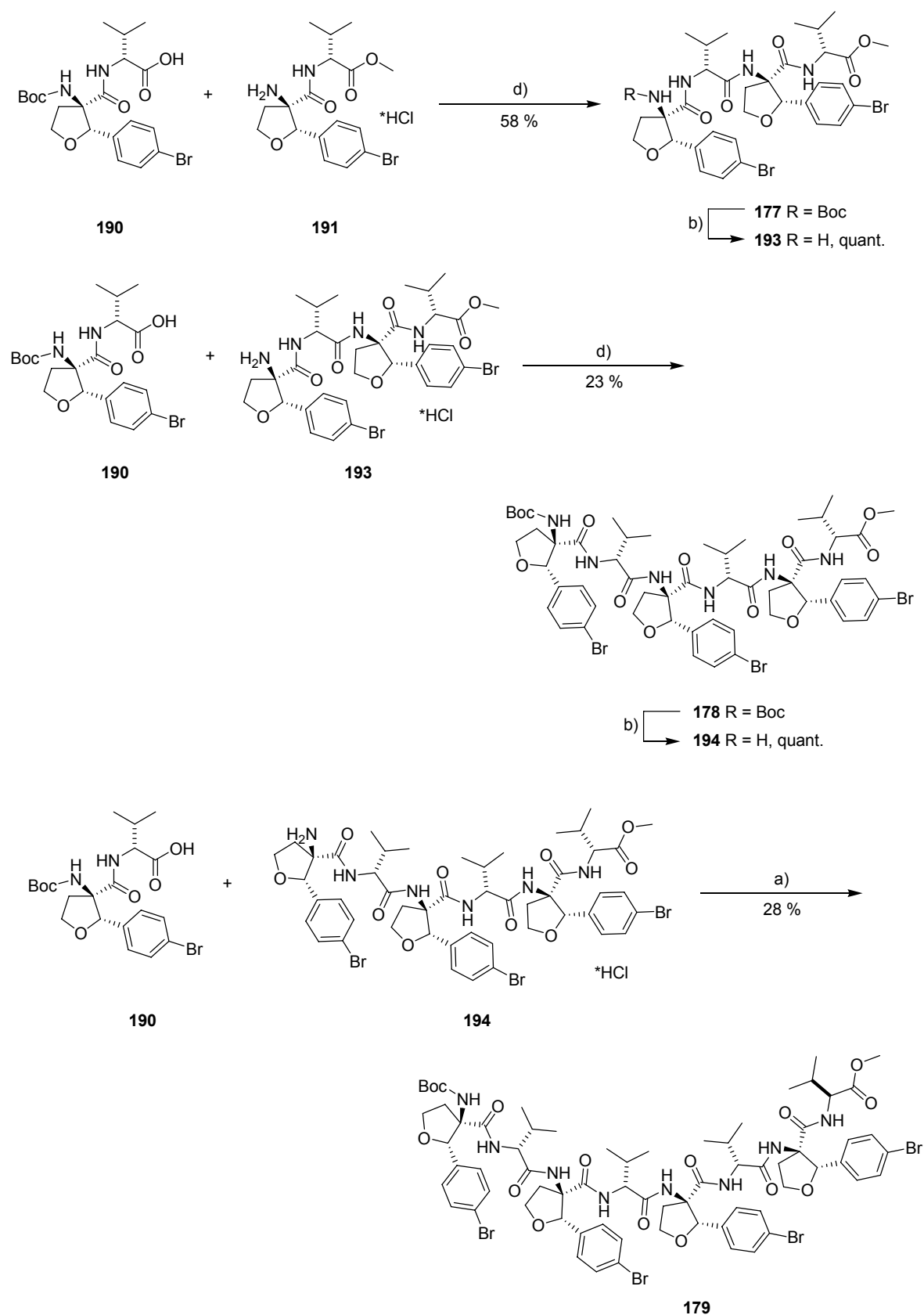

3.3. Structure Analysis of the Synthesized Peptides

The structure of the 13 different peptides **167** – **179** was determined in the solid state by X-ray crystallography and in solution by 2D-NMR, temperature dependent $^1\text{H-NMR}$ and CD measurements.

3.3.1. Solid State Structure Analysis

From all four dipeptides crystal structures were obtained (Figure 75) showing that the pairs **167**, **173** and **170**, **176** are enantiomeric in configuration and structure. The structures indicate that molecules **170** (SS) and **176** (RR) with either two *S*-configured amino acids or two *R*-configured amino acids in their amide backbone show a turn-like structure, whereas the other two compounds **167** (RS) and **173** (SR) do not have this structural feature.

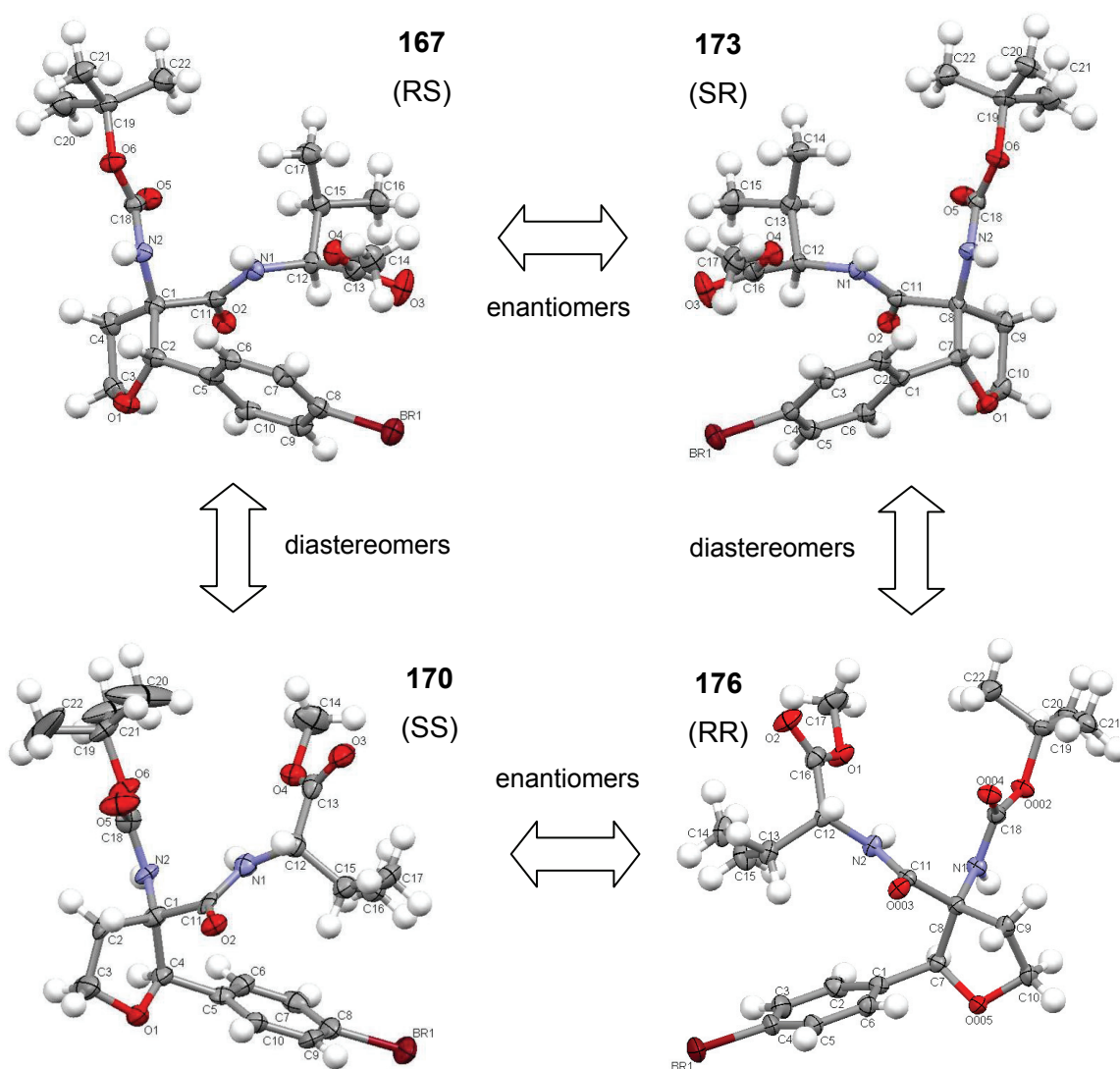

Figure 75: Crystal structures of dipeptides **167** (RS), **173** (SR), **170** (SS) and **176** (RR).

This correlation becomes even more pronounced in the structures of tetrapeptides **171** ($(SS)_2$) and **177** ($(RR)_2$), which were again determined by X-ray crystal structure analysis (Figure 76): The homochiral tetrapeptides form a characteristic 3_{10} -helix in the solid state.²³² The helix is right-handed for the all-*S*-configured peptide **171** and left-handed for the all-*R*-configured enantiomer **177**.

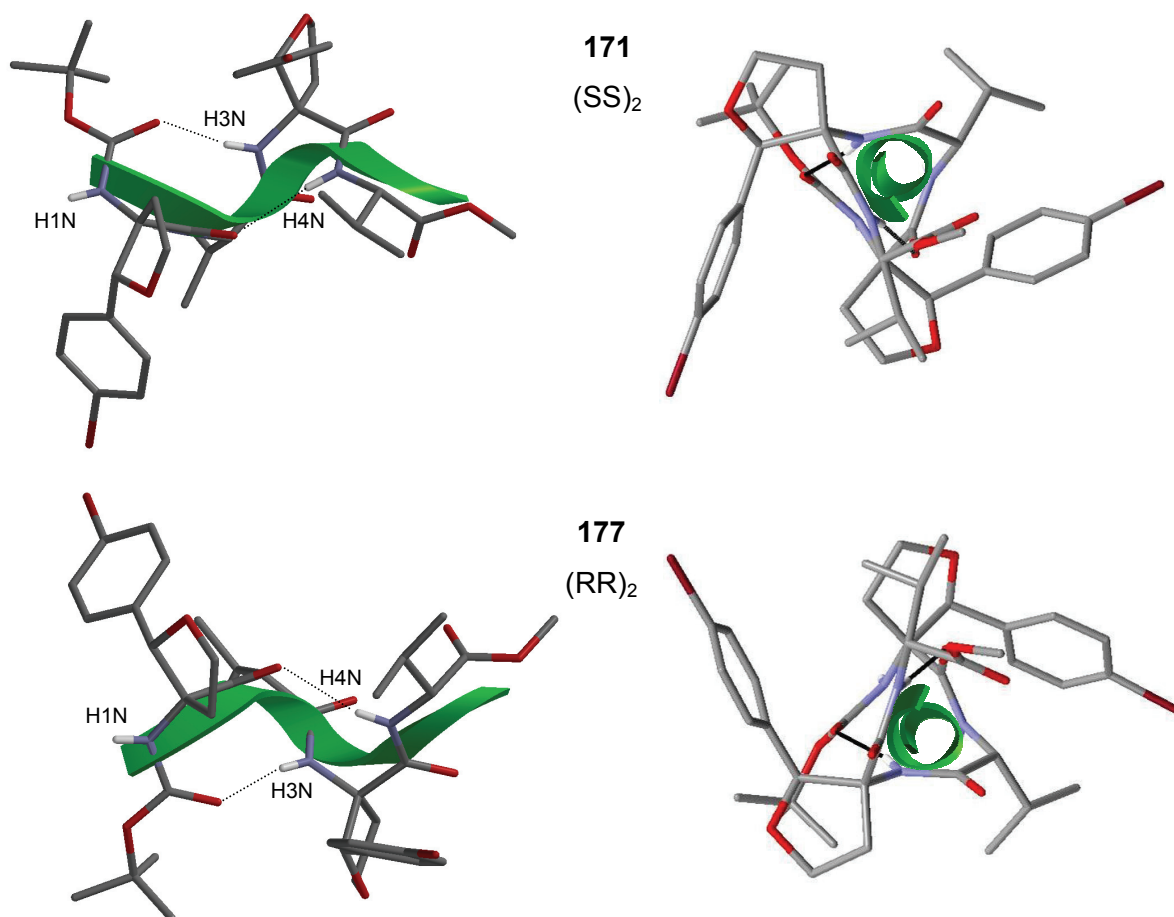

Figure 76: Crystal structures of the right-handed (top) and left-handed (bottom) helices **171** and **177** (view from the side on the left; view perpendicular to the helical axis on the right). Hydrogen atoms except NH-protons were omitted for clarity.

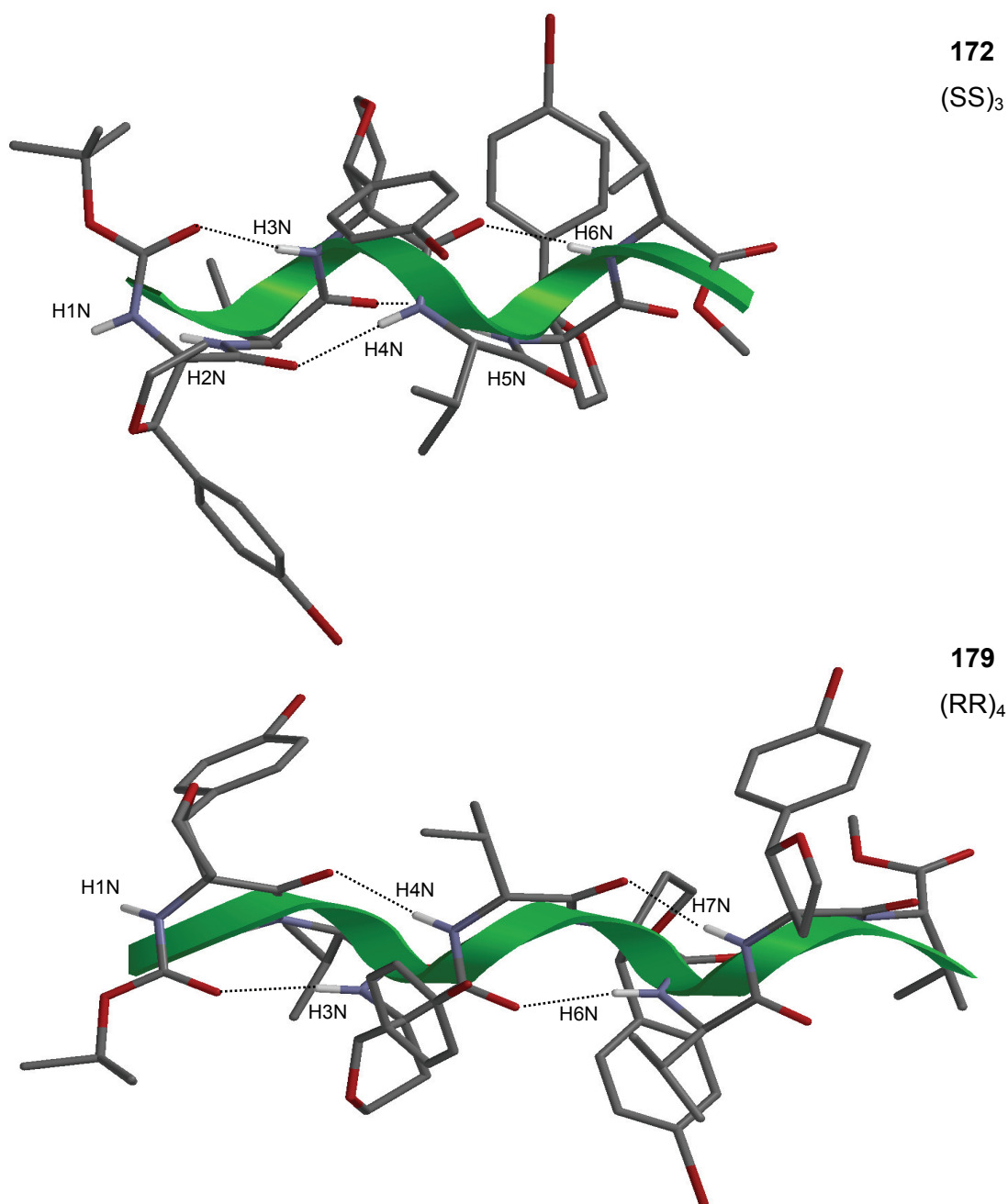

Figure 77: Crystal structures of the right-handed hexapeptide **172** (top) and the left-handed helix forming octapeptide **179** (bottom) are shown. Hydrogen atoms except NH-protons were omitted for clarity.

For both peptides **171** (SS)₂ and **177** (RR)₂ the average backbone torsion angles φ and ψ of all four amino acids were determined (Table 4). The φ -angles are between the values of an ideal 3_{10} - and an α -helix. The ψ -angles are in good agreement with those of an ideal 3_{10} -helix.²³³ One ψ -angle in compound **171** is slightly smaller than expected, while another in compound **177** is larger. This indicates the still high flexibility of the tetrapeptides that form just one turn of a 3_{10} -helix. The average $i \leftarrow i+3$ C=O \cdots N intramolecular hydrogen bond angles were found to be 133.9° (molecule **171**) and 131.9° (molecule **177**): both

values are slightly higher than those reported for other 3_{10} -helices, but still significantly smaller than those of an α -helix. The pitch (axial translation) for the two peptides being 6.61 Å (**171**) for the right-handed and 6.42 Å (**177**) for the left-handed helix, is larger than expected for a 3_{10} -helix. A slightly smaller number of residues per turn (3.16 and -3.20) leads to a higher axial translation per residue for the new tetrapeptides than for an ideal 3_{10} -helix. The extension from tetra- to hexa- and octapeptides results in smaller torsion angles φ and ψ of compounds **172** (SS)₃ (-60.2°, -26.7°) and **179** (RR)₄ (59.8°, 26.3°) and less variation in comparison to their smaller homologues **171** and **177** - **178**, respectively. This indicates a more stable structure which can be ascribed to the increased number of intramolecular hydrogen bonds. The average $i \leftarrow i+3$ C=O \cdots N intramolecular hydrogen bond angles, 133.8° for compound **172** and 132.9° for compound **179**, are in the same range as those determined for the tetrapeptides.

Table 4: Structural parameters derived from the crystal structures of compounds **171**, **172**, **177** and **179**. The literature data for an ideal right-handed 3_{10} - and an α -helix^{9a, 233} are reported for comparison.

parameter	171 (SS) ₂	177 (RR) ₂	172 (SS) ₃	179 (RR) ₄	3₁₀- helix	α-helix
φ	-61.6°	61.7°	-60.2°	59.8°	-57°	-63°
ψ	-28.4°	30.9°	-26.7°	26.3°	-30°	-42°
N \cdots O=C hydrogen bond angle	133.9°	131.9°	133.8°	132.9°	128°	156°
N \cdots O=C hydrogen bond distance	3.00 Å	2.99 Å	2.99 Å	3.04 Å	2.81 Å	2.86 Å
Rotation (per residue)	111.5°	111.1°	111.6°	111.6°	111°	99°
Residues per turn	3.16	-3.20	3.12	3.10	3.24	3.63
Axial translation (per residue)	2.09 Å	2.01 Å	2.10 Å	2.10 Å	1.94 Å	1.56 Å
Axial translation (per helical turn)	6.61 Å	6.42 Å	6.55 Å	6.51 Å	6.29 Å	5.67 Å

All $i \leftarrow i+3$ C=O \cdots H-N intramolecular H-bonds are of typical length with N \cdots O=C distances between 2.81 and 3.04 Å. This corresponds well to values of type 2 (amide–amide)

hydrogen bonds, which are of an expected $N\cdots O=C$ distance between 2.8 and 3.0 Å.²³⁴

The determined parameters and their comparison to examples from the literature assign a 3_{10} -helical geometry to all four crystal structures. However, the higher $C=O\cdots N$ intramolecular hydrogen bond angles, the reduced number of residues per turn and the higher pitch result in helices that are a little more stretched than the ideal 3_{10} -helix.

3.3.2. Solution Structure Analysis using NMR

One compound of each length (tetra-, hexa- and octamer) was investigated by NMR-spectroscopy to gain information about its structure in solution. With peptides **171** (SS)₂, **172** (SS)₃ and **179** (RR)₄, temperature dependent ¹H-NMR studies were performed in DMSO (d₆) solution (temperature range 300–373 K). Tetrapeptide **171** showed a high temperature dependency for two NH-proton resonances (N1H and N2H; -5.40 ppb/K and -5.72 ppb/K, respectively), indicating that these two protons are not involved in intramolecular hydrogen bonds. In contrast, the N3H and N4H protons are part of intramolecular hydrogen bonds, as supported by their much smaller temperature coefficients (-1.12 ppb/K for N3H and -1.72 ppb/K for N4H). These results correlate to the X-ray diffraction structure of **171**, in which protons N1H and N2H are not involved in intramolecular hydrogen bonds, while the other two (N3H and N4H) form $i \leftarrow i+3$ C=O \cdots H-N intramolecular hydrogen bonds.

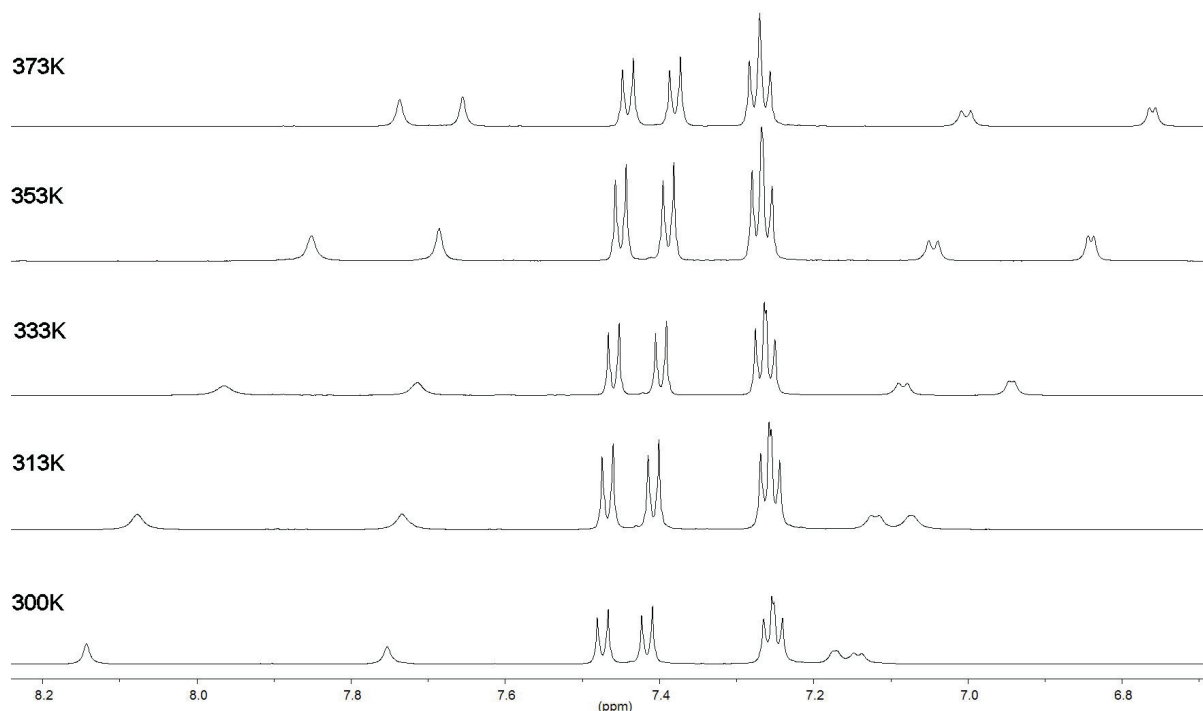

Figure 78: Part of the ¹H-NMR spectrum of **171** at different temperatures.

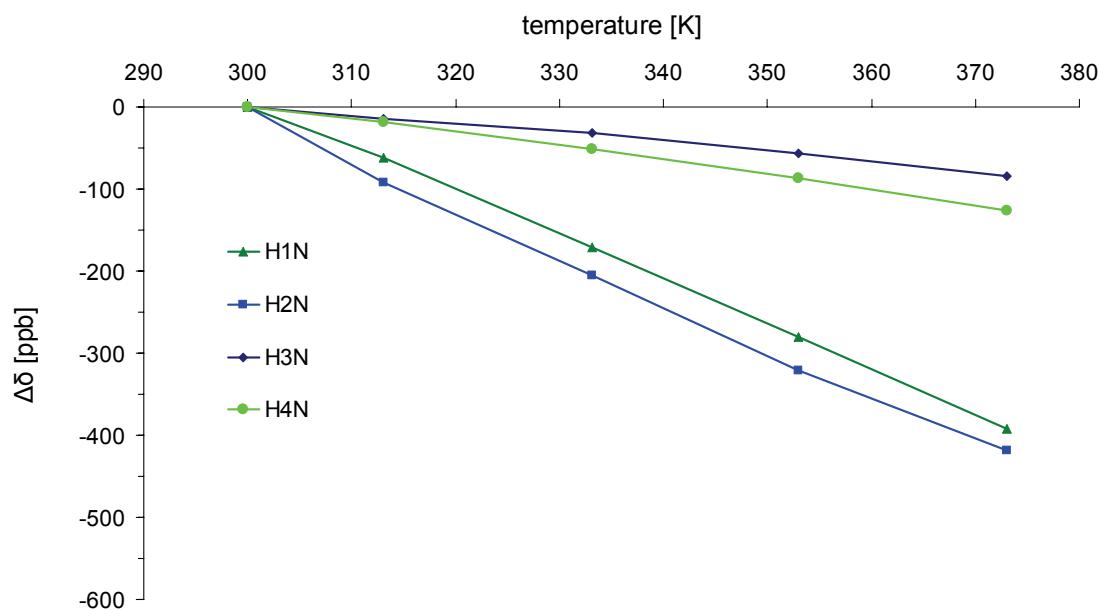

Figure 79: Temperature dependent ^1H -NMR of compound **171**.

Similar results were found for the variable temperature NMR of peptide **172**, where again two proton resonances for N1H and N2H were strongly temperature dependent (-4.63 ppb/K and -8.25 ppb/K), while the other four NH-protons involved in hydrogen bonds showed only slight resonance shifts (N3H -2.21 ppb/K, N4H -1.31 ppb/K, N5H -0.97 ppb/K, N6H -1.36 ppb/K).

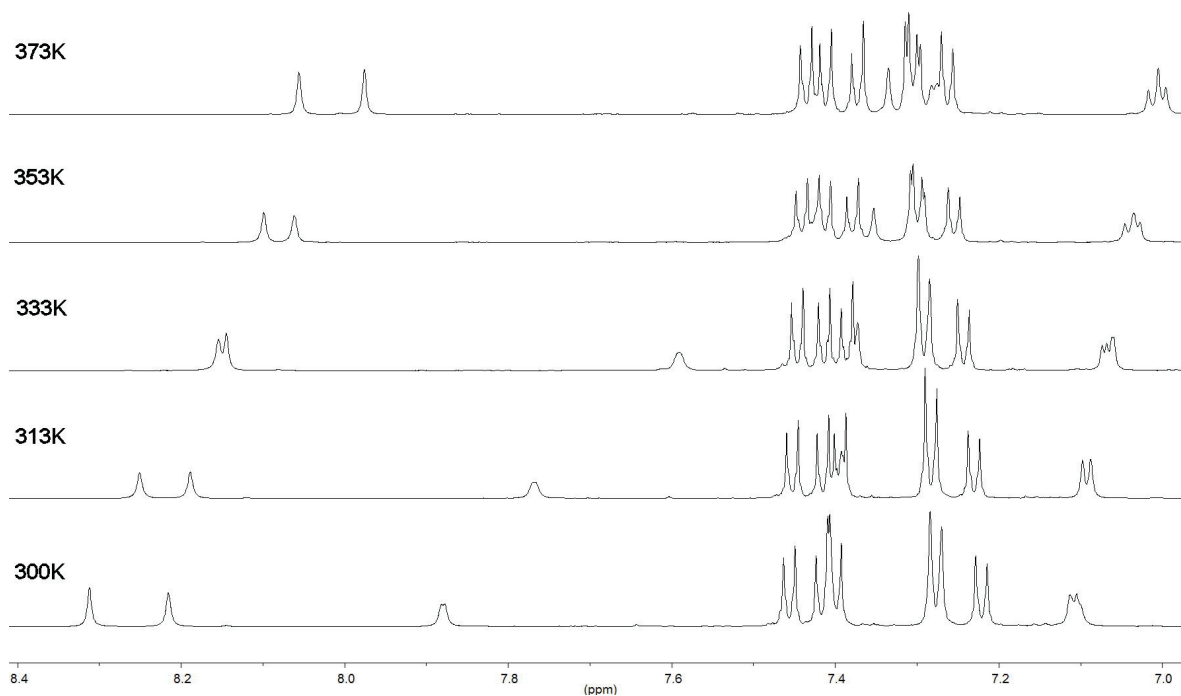

Figure 80: Part of the ^1H -NMR spectrum of **172** at different temperatures.

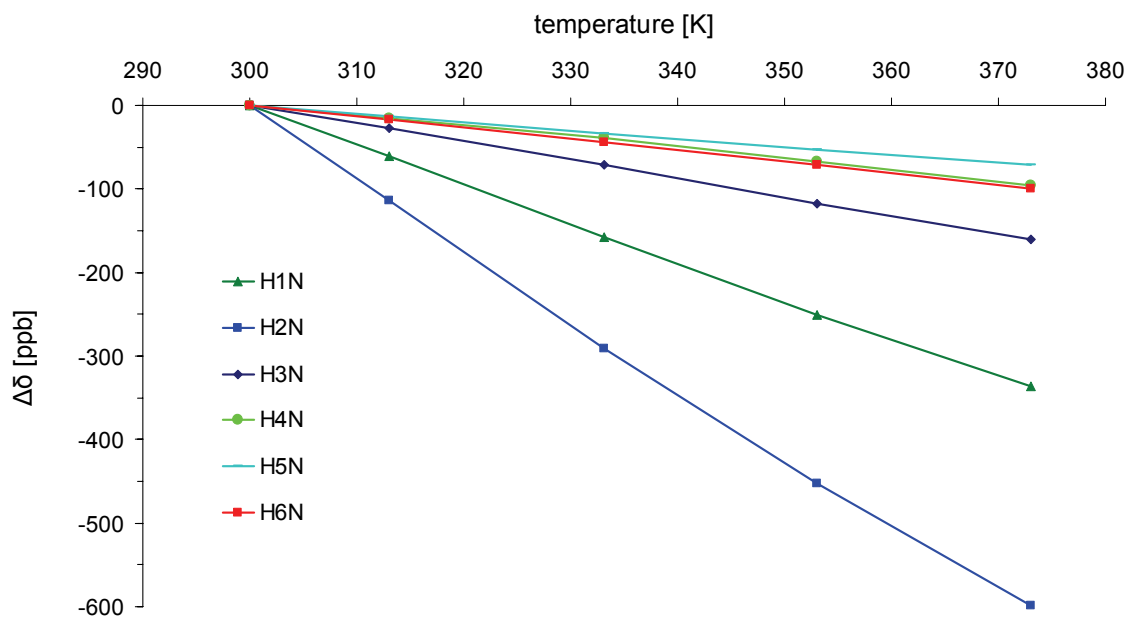

Figure 81: Temperature dependent ^1H -NMR of compound **172**.

Also for octapeptide **179** N1H and N2H exhibit large temperature coefficients (-4.56 and -7.92 ppb/K, respectively), whereas all other proton resonances have a much smaller temperature dependency (N3H -1.68 ppb/K, N4H -0.82 ppb/K, N5H -1.00 ppb/K, N6H -1.20 ppb/K, N7H -0.77 , N8H -1.99). These results clearly show that all peptides adopt a stable C-terminal helical structure in solution.

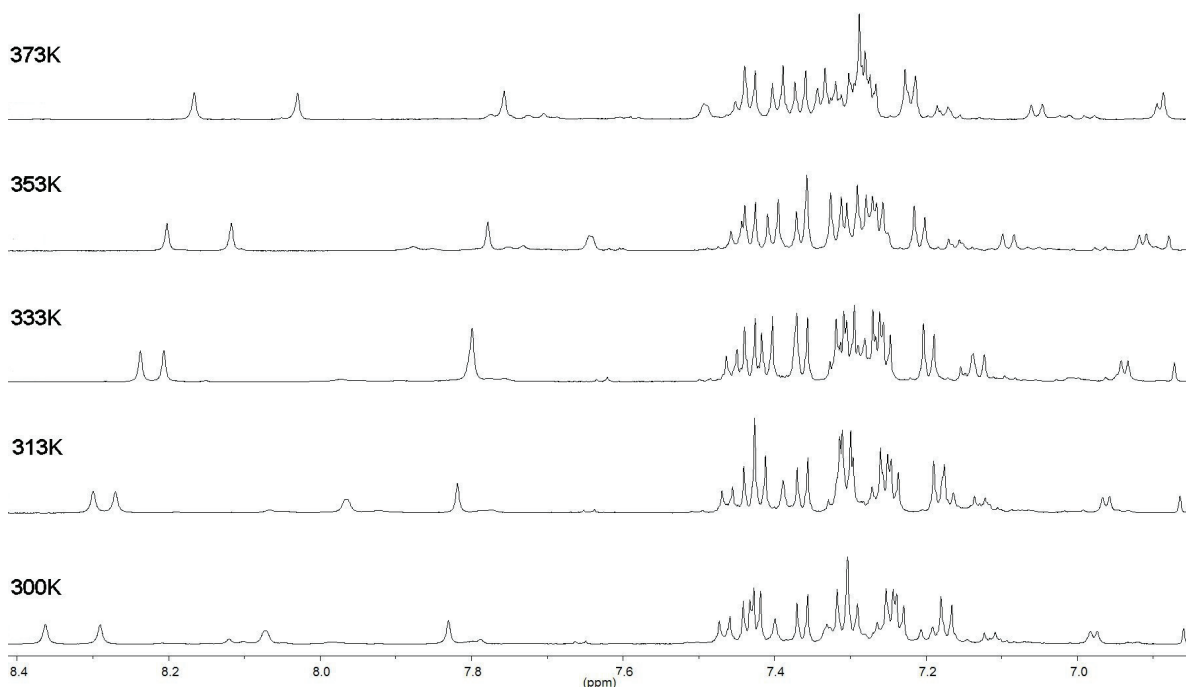

Figure 82: Part of the ^1H NMR spectrum of **179** at different temperatures.

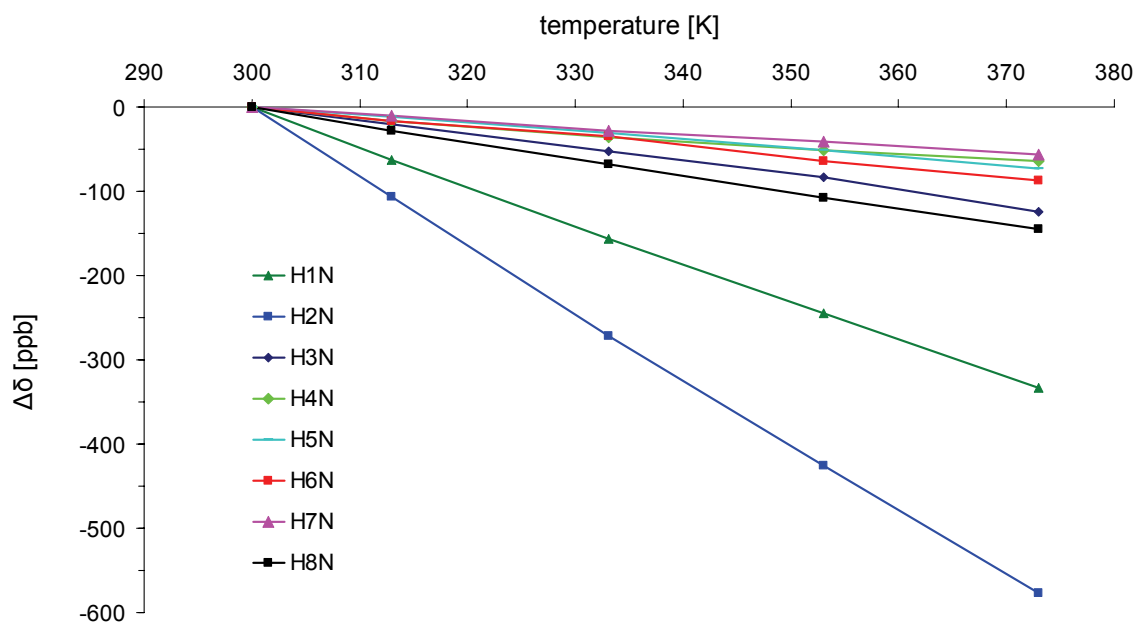

Figure 83: Temperature dependent ^1H -NMR of compound **179**.

It is known that short peptides containing C^α -tetrasubstituted α -amino acids can undergo an $\alpha/3_{10}$ -helix transition in solution.²³⁵ To determine the predominant helix type in DMSO, ROESY spectra of **171**, **172** and **179** were recorded in DMSO (d_6).

For all three peptides strong sequential d_{NN} NOE cross-peaks were observed. These cross-peaks evoke from the interaction of the NH proton of amino acid i with the NH proton of amino acid $i+1$ and are characteristic for helical structures in solution and with that provide another proof for the helical structure adopted by the investigated peptides in solution.

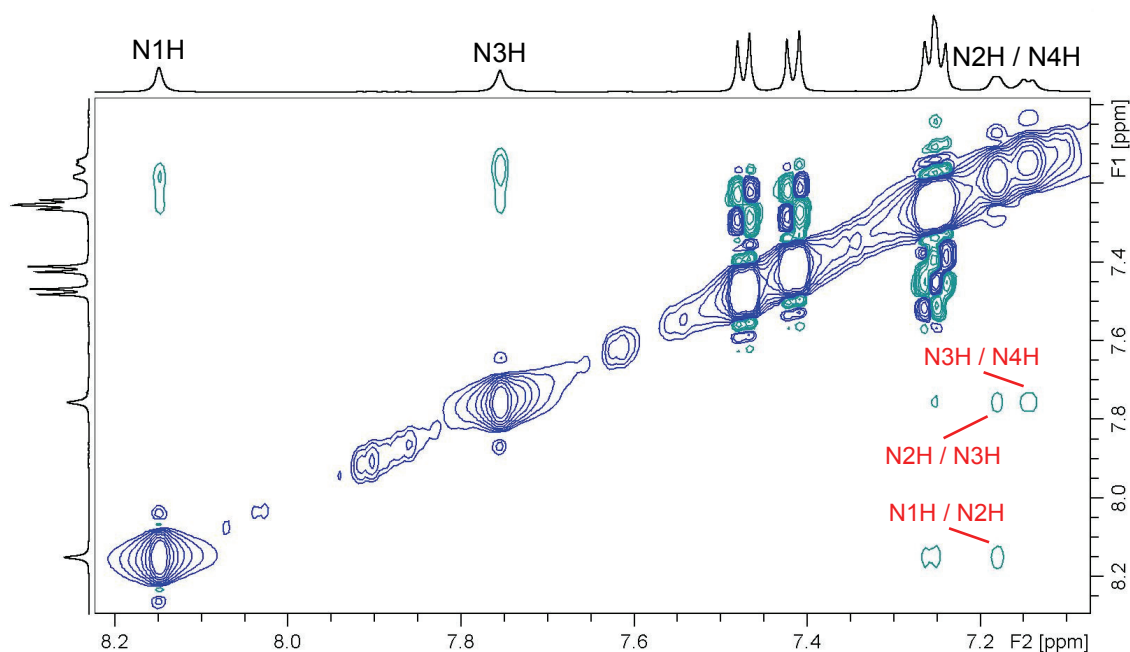

Figure 84: Part of the ROESY spectra of compound **171** in DMSO- d_6 .

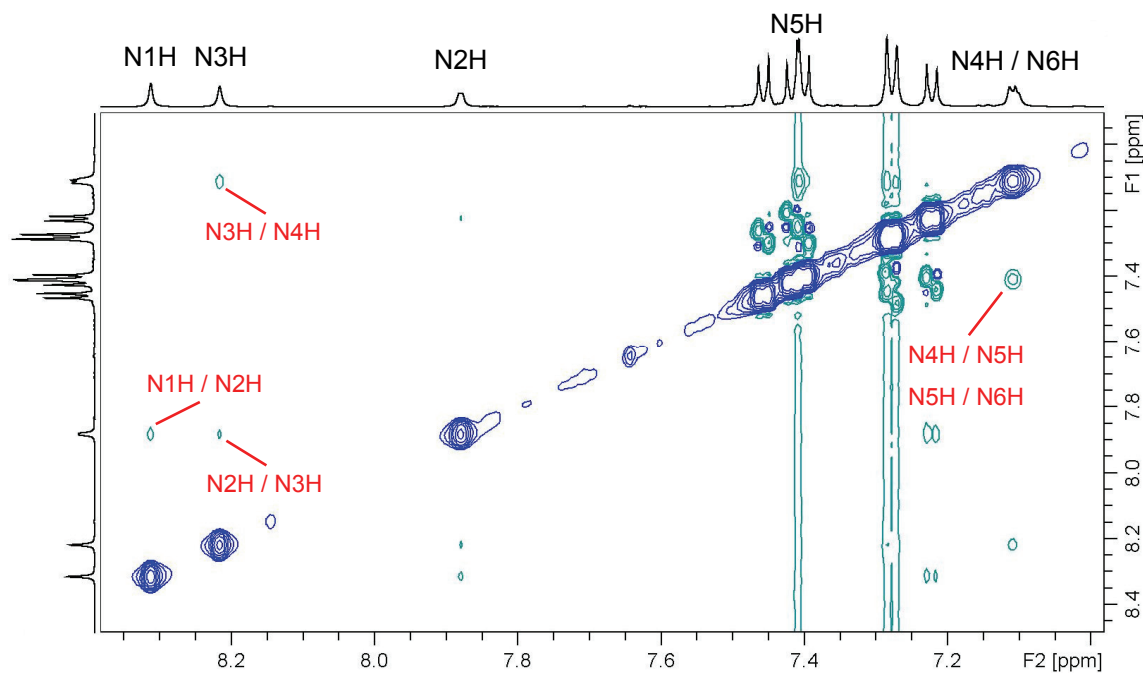

Figure 85: Part of the ROESY spectra of compound **172** in DMSO- d_6 .

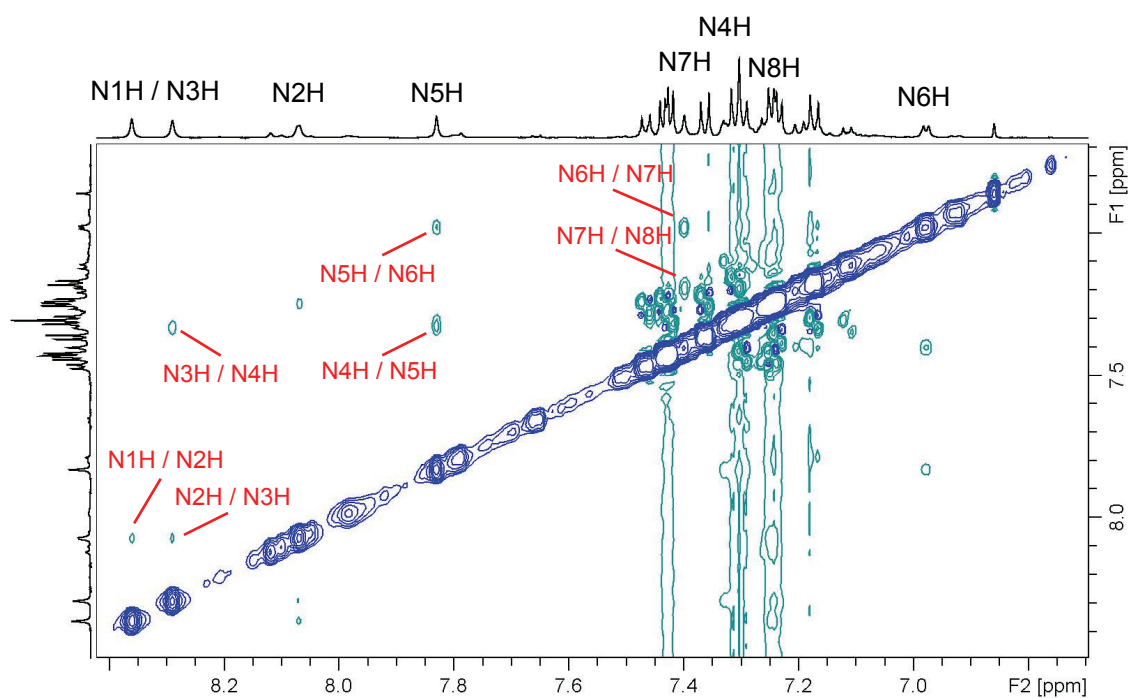

Figure 86: Part of the ROESY spectra of compound **179** in DMSO- d_6 .

To discriminate between α - and 3_{10} -helix, the ROE spectra were searched for the $d_{\alpha\text{N}}(i, i+2)$ contacts characteristic for 3_{10} -helices and the $d_{\alpha\text{N}}(i, i+4)$ contacts normally observed for α -helices. These cross signals originate from the interaction between the C^α -proton of amino acid i and the NH proton of amino acid $i+2$ or $i+4$. In contrast to peptides consisting only of C^α -tetrasubstituted α -amino acids, in our case it was possible to observe this kind

of interaction due to the presence of valine in the peptide chain.

For the tetrapeptide **171** only the $d_{\alpha N}(i, i+2)$ ($i = 2$) was found indicating the presence of a C-terminal 3_{10} -helix.

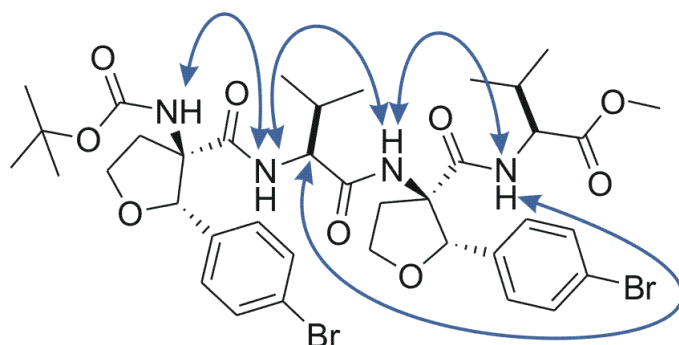

Figure 87: $d_{NN}(i, i+1)$ ($i = 1 - 3$) and $d_{\alpha N}(i, i+2)$ ($i = 2$) NOE contacts of **171** detected spectroscopically in a DMSO- d_6 solution.

For the hexapeptide **172** two $d_{\alpha N}(i, i+2)$ ($i = 2$ and 4) cross-peaks were found, but no $d_{\alpha N}(i, i+4)$ ($i = 2$) NOE contact was detected. Accordingly, these findings clearly indicate a preference for the formation of a 3_{10} -helix over an α -helix.

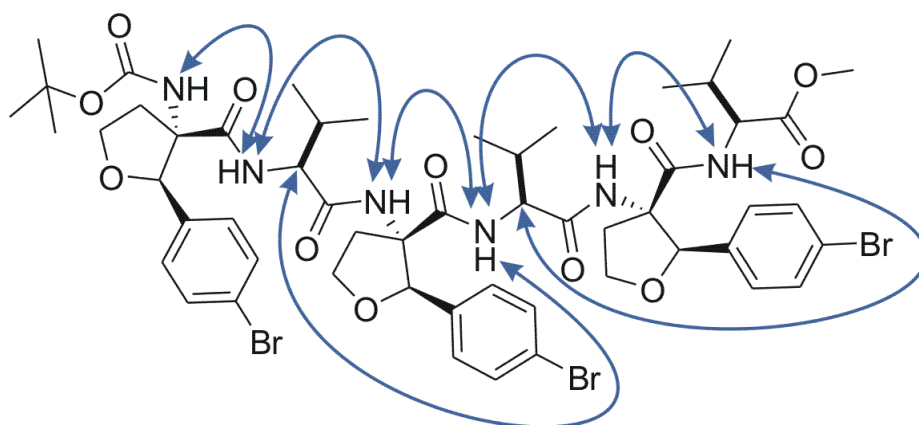

Figure 88: $d_{NN}(i, i+1)$ ($i = 1 - 5$) and $d_{\alpha N}(i, i+2)$ ($i = 2$ and 4) NOE contacts of **172** detected spectroscopically in a DMSO- d_6 solution.

For compound **179** no structural insights could be obtained by its ROESY spectrum, due to strong overlap of the C^α -proton resonances.²³⁶

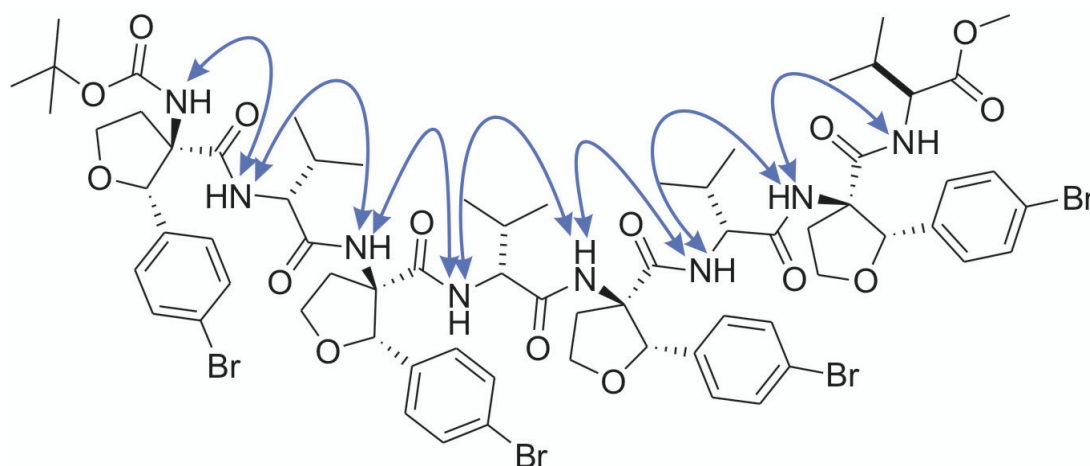

Figure 89: $d_{\text{NN}}(i, i+1)$ ($i = 1 - 7$) NOE contacts of **179** detected spectroscopically in a DMSO- d_6 solution.

The NMR measurements strongly indicate that the investigated peptides based on alternating natural and C^α-tetrasubstituted unnatural α -amino acids form stable helices in solution, as they do in solid state. The tetra- and hexamers prefer a 3_{10} -helix structure in deuterated DMSO.

3.3.3. Solution Structure Analysis using Circular Dichroism

The conformation of all synthesized peptides was further investigated in methanol by CD spectroscopy.³

Figure 90 shows the effect of the peptide chain length elongation on the dichroic properties of the oligopeptides. Peptides **167** (RS), **168** (RS)₂ and **169** (RS)₃ which have no helix character based on the NMR investigation, show two opposite CD bands near 210 nm (positive) and 222 nm (negative), with a crossover close to 215 nm. The intensity of the CD spectra decreases by increasing the peptide-chain length. Similarly, peptides **174** (SR)₂ and **175** (SR)₃ (no helix character based on NMR) are characterized by much less intense CD curves than dipeptide **173** (SR): they still show a broad minimum near 210 nm, whereas the positive shoulder of **173** at 230 nm disappears, until it becomes a weak negative shoulder for hexapeptide **175**.

³ The interpretation of the measured data was accomplished with the help of Prof. Dr. C. Cabrele (Ruhr-Universität Bochum).

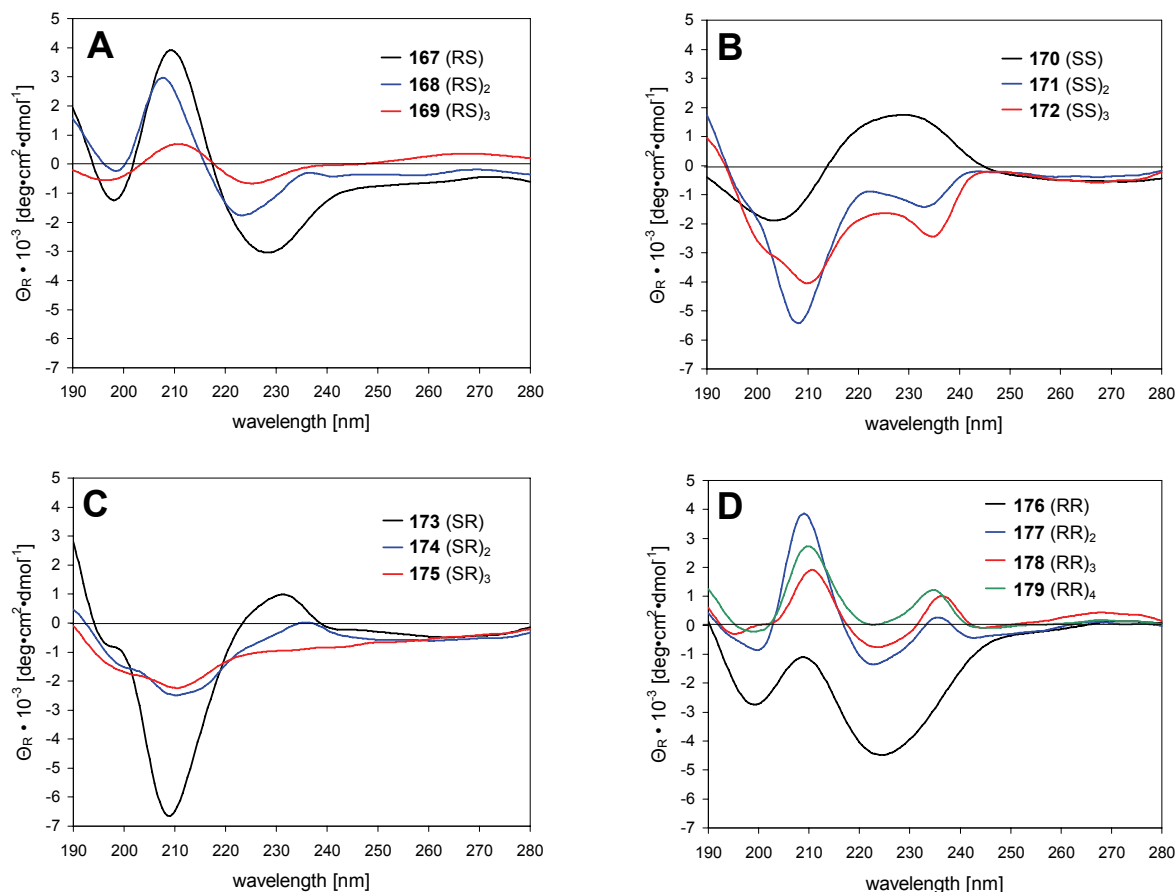

Figure 90: CD-Spectra of compounds **167 - 169** (RS)₁₋₃ (panel **A**), **170 - 172** (SS)₁₋₃ (panel **B**), **173 - 175** (SR)₁₋₃ (panel **C**) and **176 - 179** (RR)₁₋₄ (panel **D**), recorded in methanol at a peptide concentration of 1mM.

Upon elongation of dipeptide **170** (SS) to tetrapeptide **171** (SS)₂ and hexapeptide **172** (SS)₃ (right-handed 3_{10} -helix in the crystal), the minimum near 205 nm is slightly red-shifted and increases in intensity, whereas the positive CD contribution above 215 nm is substituted by a negative maximum near 222 nm, followed by a minimum near 234 nm.

The CD spectra of peptides **177 - 179** (RR)₂₋₄ (left-handed 3_{10} -helix in the crystal) are reminiscent of the one of dipeptide **176** (RR), but shifted towards positive ellipticity values, which leads to the appearance of a maximum near 210 nm and a positive valley near 222 nm. Moreover, a new positive band is detected near 233 nm, whose intensity increases when going from tetrapeptide **177** up to octapeptide **179**. The corresponding enantiomers **171** (SS)₂ and **172** (SS)₃ also show this band, obviously opposite in sign, whereas the tetra- and hexapeptides from the (RS) and (SR) series do not (Figure 91): as only the peptides from the (RR) and (SS) series adopt a 3_{10} -helical structure in the crystal and show NOEs characteristic of helical structures, this band near 233 nm, together with the increased CD intensity in the range of 210-230 nm, should reflect the presence of an ordered structure that becomes better defined in the larger oligopeptides (CD intensity

over 210-230 nm: **172** > **171**, and **179** > **178** > **177**).

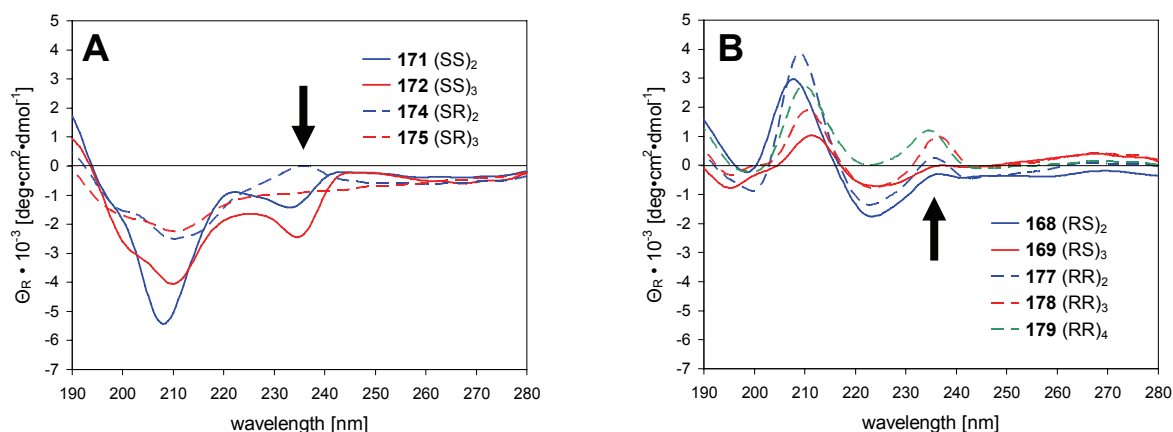

Figure 91: Comparison of the CD-Spectra of the helical peptides **171**, **172** (panel **A**) and **177** - **179** (panel **B**) with the non-helical oligomers **174**, **175** and **168**, **169**, respectively.

We assume that the dipeptides contain the highest amount of disordered and irregular conformations. Therefore, the increase in the ordered peptide fraction of the larger peptides can be visualized by subtracting the CD spectrum of the dipeptides from the CD spectra of the larger peptides. This eliminates the CD contribution of the disordered fraction and possible CD contributions from the aromatic group of the TAA. The difference CD spectra for the four peptide series (SS, RR, SR, RS) are shown in Figure 92. The difference CD spectra obtained for the peptides (SS)₂₋₃ and (RR)₂₋₄ that adopt a right-handed and left-handed 3₁₀-helix, respectively, in the crystal are characterized by a red-shifted helix-like band pattern (panel **A** of Figure 92), with two minima for (**171–170**) and (**172–170**), or two maxima for (**177–176**), (**178–176**) and (**179–176**) near 210 nm and 230 nm.

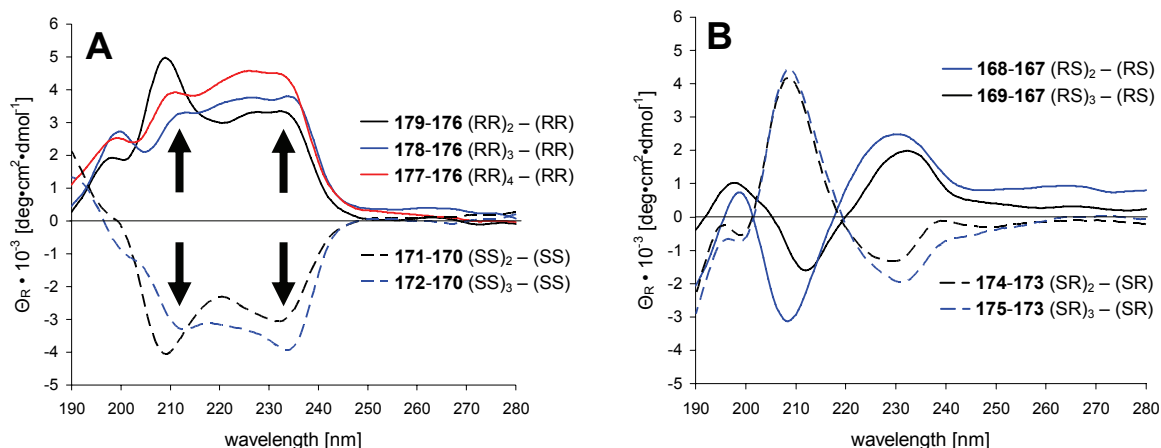

Figure 92: Difference CD spectra of oligopeptides (RR)₂₋₄ minus dipeptide (RR) and of oligopeptides (SS)₂₋₃ minus dipeptide (SS) are shown in panel **A**. Difference CD spectra of oligopeptides (RS)₂₋₃ minus dipeptide (RS) and of oligopeptides (RS)₂₋₃ minus dipeptide (RS) are shown in panel **B**.

The remarkable red shift of the longer wavelength band can be due to the highly hydrophobic character of the peptides.²³⁷ The intensity of the spectra increases with the peptide length, suggesting an increase in ordered structure; moreover, for the tetrapeptides of both series the ratio between the ellipticity values at 230 nm and 210 nm is < 1 , whereas for the larger peptides this ratio becomes > 1 . This suggests that the tetrapeptides are likely to form both a 3_{10} - and an α -helical turn in methanol, whereas the larger peptides are able to build a stable short α -helix. The tendency of peptide chains with eight or more amino acids in length to form an preferred α -helical structure was previously described.^{9a} The difference CD spectra obtained for the peptides (SR)₂₋₃ and (RS)₂₋₃ are completely different from those ones of the peptides (SS)₂₋₃ and (RR)₂₋₄, which excludes a helical conformation.

3.4. Conclusion

In summary, 13 new peptides based on an alternated sequence of the *S*- or *R*-configured α -amino acid valine and the unnatural C ^{α} -tetrasubstituted tetrahydrofuran α -amino acid *rac*-**138** were prepared. Homo- and heterochiral stereoisomers with up to eight residues in length were systematically synthesized in good yields and high purity by solution phase chemistry. X-ray crystallography, NMR- and CD-measurements showed that all homochiral peptides, even the tetrapeptides, form helical structures in the solid state and in solution. The handedness of the helix is determined by the use of *S*-amino acids for right-handed or *R*-amino acids for left-handed peptide helices.

The stable and predictable secondary structure of the new peptides makes them suitable for applications as scaffolds and peptidomimetics. Additional moieties e.g. dyes, can be introduced by metal catalyzed functionalization of the brominated arene substituent (see Chapter 3).²¹⁸ Comparison of the crystallographic data of octamer **179** (RR)₄ with an idealized α -helix geometry reveals that the residues *i*, *i*+3 and *i*+6 of the octamer correspond to residues *i*, *i*+3 and *i*+7 of the natural α -helix. These positions are of importance for numerous protein-protein interactions, as the side chains of these residues are located on the same face of an amphipathic α -helical protein or peptide segment.²³⁸

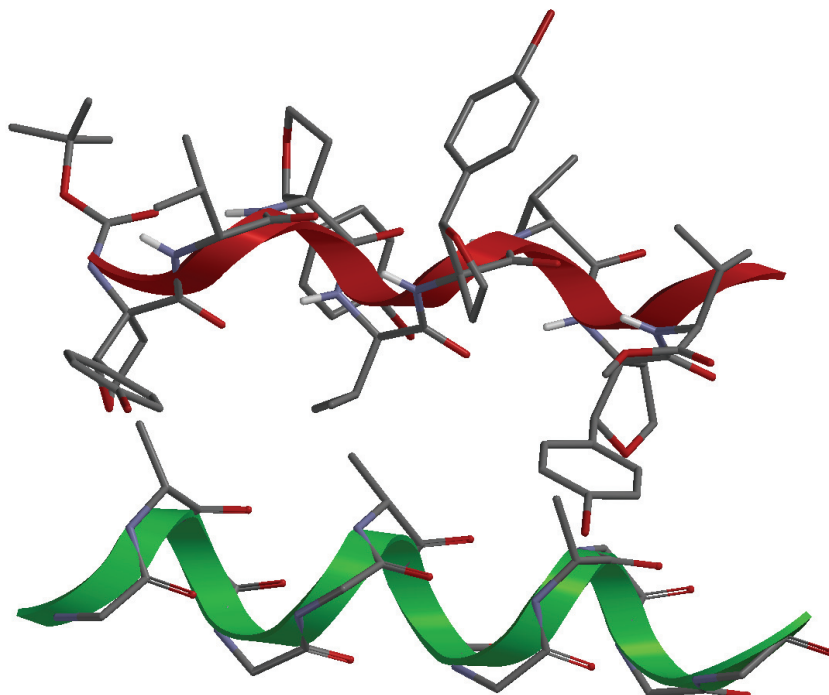

Figure 93: Crystal structure of compound **179** (red ribbon, top) and of an α -helix (green ribbon, bottom). The *i*, *i*+3 and *i*+6 residues of peptide **179** are in close proximity to the *i*, *i*+3 and *i*+7 side chains of the natural α -helix (in this example alanine was used to indicate the side chains of the natural peptide).

3.5. Experimental Part

General

A Jasco Model J-710 spectropolarimeter was used. A 0.5 mm quartz cell was purchased from Hellma and Uvasol solvents from Merck. X-ray data collections were performed using an Oxford Gemini Ultra diffractometer. IR spectra were recorded on a Bio-Rad FT-IR FTS 155 and a Bio-Rad FTS 2000 MX FT-IR using a Specac Golden Gate Mk II ATR accessory where stated. NMR spectrometers used were: Bruker Avance 600 (^1H : 600.1 MHz, ^{13}C : 150.1 MHz, T = 300 K), Bruker Avance 400 (^1H : 400.1 MHz, ^{13}C : 100.6 MHz, T = 300 K) and Bruker Avance 300 (^1H : 300.1 MHz, ^{13}C : 75.5 MHz, T = 300 K). The chemical shifts are reported in δ [ppm] relative to external standards (solvent residual peak). The spectra were analyzed by first order, the coupling constants are given in Hertz [Hz]. Characterization of the signals: s = singlet, d = doublet, t = triplet, q = quartet, m = multiplet, bs = broad singlet, psq = pseudo quintet, dd = double doublet, dt = double triplet, ddd = double double doublet. Integration is determined as the relative number of atoms. Assignment of signals in ^{13}C -spectra was determined with DEPT-technique (pulse angle: 135°) and given as (+) for CH_3 or CH, (-) for CH_2 and (C_{quat}) for quaternary C. Error of reported values: chemical shift: 0.01 ppm for ^1H -NMR, 0.1 ppm for ^{13}C -NMR and 0.1 Hz for coupling constants. The solvent used is reported for each spectrum. Mass spectra were recorded on Varian CH-5 (EI), Finnigan MAT 95 (CI; FAB and FD) and Finnigan MAT TSQ 7000 (ESI). Xenon served as the ionization gas for FAB. Melting Points were determined on a Büchi SMP-20 or Stanford Research System OpitMelt melting point apparatus and are uncorrected. Elemental analyses were carried out by the Center for Chemical Analysis of the Faculty of Natural Sciences of the University Regensburg.

All reagents and solvents used were of analytical grade purchased from commercial sources and were used without further purification. Unless stated otherwise, purification and drying of the solvents used was done according to accepted general procedures.²³⁹

All reactions were performed under an inert atmosphere of N_2 using standard Schlenk techniques if not otherwise stated. TLC analyses were performed on silica gel 60 F-254 with a 0.2 mm layer thickness. Detection was via UV light at 254 nm / 366 nm or through discoloration with ninhydrin in EtOH. For preparative column-chromatography, Merck Geduran SI 60 (70-230 mesh) and Macherey-Nagel GmbH & Co. KG 60M (230–400 mesh) silica gels were used. For chromatography commercially available solvents of standard quality were used without further purification.

The unnatural amino acid Boc-TAA-OH *rac*-**137** was synthesized according to a literature known procedure.²¹⁸

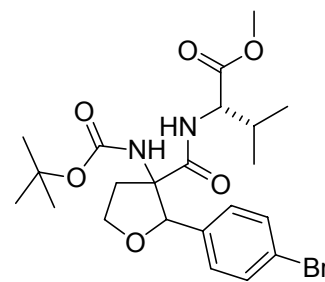

(2S)-Methyl 2-(2-(4-bromophenyl)-3-(tert-butoxycarbonylamino)-tetrahydrofuran-3-carboxamido)-3-methylbutanoate (167/170):

Under an atmosphere of nitrogen compound *rac*-**138** (1.50 g, 3.88 mmol, 1 eq.) was dissolved in 3.9 ml DMF (1 ml/mmol) and cooled to 0 °C in an ice bath. To the solution DIPEA (1.99 ml, 11.7 mmol, 3 eq.), HOBt (793 mg, 5.83 mmol, 1.5 eq.) and EDC (1.03 ml, 5.83 mmol, 1.5 eq.) were added in this sequence. Then H-Val-OMe*HCl **180** (911 mg, 5.44 mmol, 1.4 eq.) was slowly added in portions. The mixture was allowed to warm to room temperature and stirred for 24 h. The reaction was quenched with 6 ml of water and 4 ml of 1M aqueous KHSO₄ and extracted with diethyl ether (3x10 ml). The combined organic layers were washed twice with brine. Afterwards the solution was dried over MgSO₄ and concentrated under reduced pressure. The crude product was then purified by column chromatography on flash silica gel (PE:diethyl ether 80:20) to give the product as two diastereomers as colorless solids with an overall yield of 76 % (1.47 g, 2.94 mmol).

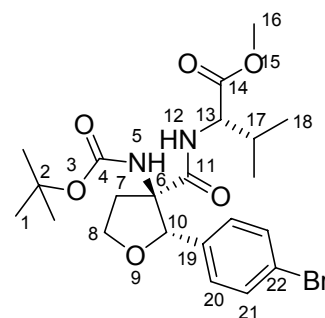

167: R_f (PE:diethyl ether 70:30) = 0.24

MP 147 °C. – **¹H-NMR** (300 MHz, CDCl₃): δ = 0.48 (d, ³J_{H,H} = 6.9, 3 H, 18), 0.61 (d, ³J_{H,H} = 6.9, 3 H, 18), 1.47 (s, 9 H, 1), 1.86 (septet, ³J_{H,H} = 4.6, ³J_{H,H} = 6.8, 1 H, 17), 2.52-2.71 (m, 1 H, 7), 2.73-2.92 (m, 1 H, 7), 3.70 (s, 3 H, 16), 4.21 (dd, ³J_{H,H} = 4.4, ³J_{H,H} = 8.5, 1 H, 13), 4.27-4.45 (m, 2 H, 8), 5.42 (bs, 1 H, 10), 6.16 (bs, 1 H, NH), 6.48 (d, ³J_{H,H} = 8.0, 1 H, NH), 7.24 (d, ³J_{H,H} = 8.2, 2 H, 20), 7.41 (d, ³J_{H,H} = 8.5, 2 H, 21). – **¹³C-NMR** (75 MHz, CDCl₃): δ = 17.3 (+, 1 C, 18), 18.3 (+, 1 C, 18), 28.4 (+, 3 C, 1), 31.0 (+, 1 C, 17), 36.1 (-, 1 C, 7), 52.2 (+, 1 C, 16), 57.3 (+, 1 C, 13), 66.6 (-, 1 C, 8), 67.5 (C_{quat}, 1 C, 6), 80.2 (C_{quat}, 1 C, 2), 80.4 (+, 1 C, 10), 121.6 (C_{quat}, 1 C, 22), 127.0 (+, 2 C, 20), 131.3 (+, 2 C, 21), 136.4 (C_{quat}, 1 C, 19), 154.2 (C_{quat}, 1 C, 4), 171.2 (C_{quat}, 1 C, 11), 172.1 (C_{quat}, 1 C, 14). – **MS** (Cl, NH₃):

m/z (%) = 500.9 (100) $[\text{MH}^+]$, 518.0 (17) $[\text{MNH}_4^+]$. – **Elemental analysis** calcd. (%) for $\text{C}_{22}\text{H}_{31}\text{BrN}_2\text{O}_6$ (499.4): C 52.95, H 6.28, N 5.59; found: C 53.02, H 6.33, N 5.50. – **IR** (neat) $[\text{cm}^{-1}]$: $\tilde{\nu}$ = 3384, 3271, 2959, 2518, 2361, 1725, 1673, 1527, 1491, 1437, 1373, 1211, 1147, 1072, 1009, 830, 802. – **MF** $\text{C}_{22}\text{H}_{31}\text{BrN}_2\text{O}_6$. – **MW** 499.4.

X-Ray structure and crystal data of **167**:

Monoclinic; space group: C 2; cell dimensions: $a = 19.0217(5)$ Å, $\alpha = 90^\circ$, $b = 6.13650(10)$ Å, $\beta = 106.897(3)^\circ$, $c = 20.6038(5)$ Å, $\gamma = 90^\circ$; $V = 2301.19(10)$ Å³; $Z = 4$, $D_x = 1.441$ Mg/m³; $\mu = 2.776$ mm⁻¹; $F(000) = 1040$. Data collection: $T = 123$ K; graphite monochromator. A colorless crystal with dimensions of 0.490 x 0.070 x 0.050 mm was used to measure 7262 reflections (3078 unique reflections, $R_{\text{int}} = 0.0455$) from 2.24° to 62.28° on a Oxford Diffraction Gemini Ultra diffractometer with the omega-scan method. Structure refinement: The F^2 value was refined using the full-matrix least squares refinement method, with a goodness-of-fit of 1.020 for all reflections and 286 parameters.

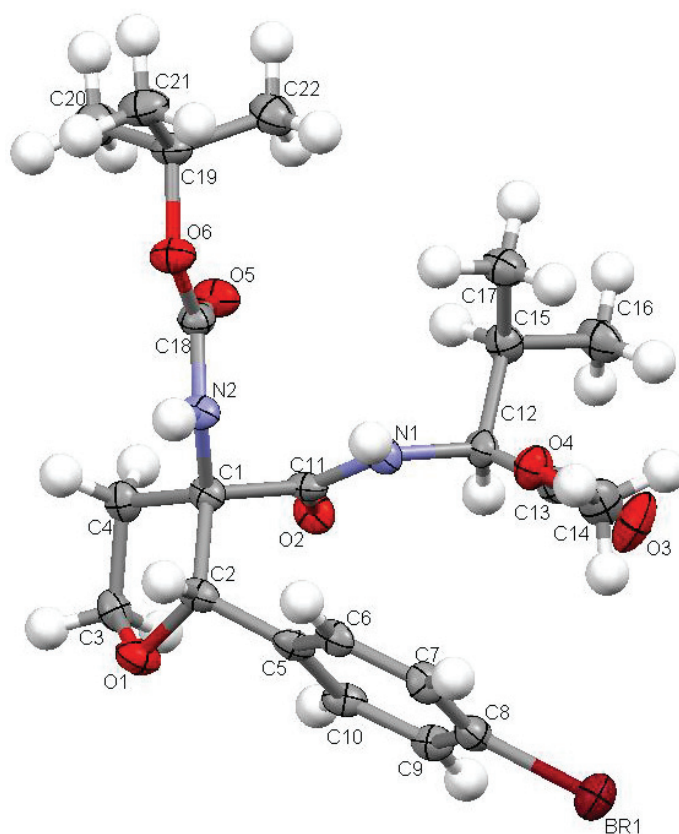

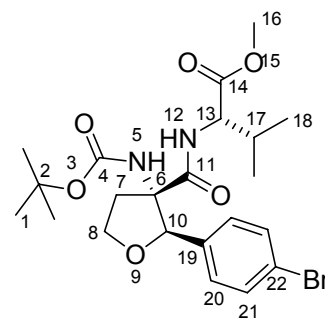

170: R_f (PE:diethyl ether = 70:30) = 0.20

MP 135 °C. – **$^1\text{H-NMR}$** (300 MHz, benzene- d_6): δ = 0.68 (d, $^3J_{\text{H,H}}$ = 6.9, 6 H, 18), 1.44 (s, 9 H, 1), 1.70-1.91 (m, 1 H, 17), 2.22-2.42 (m, 1 H, 7), 2.59-2.81 (m, 1 H, 7), 3.15 (s, 3 H, 16), 3.75-3.94 (m, 1 H, 13), 3.92 (dd, $^3J_{\text{H,H}}$ = 7.1, $^3J_{\text{H,H}}$ = 16.2, 8), 4.27 (dd, $^2J_{\text{H,H}}$ = 4.9, $^3J_{\text{H,H}}$ = 7.9, 1 H, 8), 5.51 (bs, 1 H, 10), 6.40 (s, 1 H, NH), 6.75 (d, $^3J_{\text{H,H}}$ = 5.8, 1 H, NH), 7.20 (d, $^3J_{\text{H,H}}$ = 8.5, 2 H, 20), 7.30 (d, $^3J_{\text{H,H}}$ = 8.2, 2 H, 21). – **$^{13}\text{C-NMR}$** (75 MHz, CDCl_3): δ = 17.9 (+, 1 C, 18), 18.7 (+, 1 C, 18), 28.4 (+, 3 C, 1), 31.8 (+, 1 C, 17), 36.1 (-, 1 C, 7), 52.1 (+, 1 C, 16), 57.2 (+, 1 C, 13), 66.5 (-, 1 C, 8), 67.6 (C_{quat} , 1 C, 6), 80.2 (C_{quat} , 1 C, 2), 80.7 (+, 1 C, 10), 121.6 (C_{quat} , 1 C, 22), 127.3 (+, 2 C, 20), 131.0 (+, 2 C, 21), 135.5 (C_{quat} , 1 C, 19), 154.3 (C_{quat} , 1 C, 4), 171.3 (C_{quat} , 1 C, 11 + 14). – **MS** (Cl, NH_3): m/z (%) = 500.9 (100) [MH^+], 518.0 (33) [MNH_4^+]. – **Elemental analysis** calcd. (%) for $\text{C}_{22}\text{H}_{31}\text{BrN}_2\text{O}_6$ (499.4): C 52.91, H 6.26, N 5.61; found: C 53.02, H 6.33, N 5.50. – **IR** (neat) [cm^{-1}]: $\tilde{\nu}$ = 3440, 3271, 2957, 2874, 2357, 1742, 1719, 1652, 1507, 1367, 1244, 1162, 1088, 1014, 987, 798. – **MF** $\text{C}_{22}\text{H}_{31}\text{BrN}_2\text{O}_6$. – **MW** 499.4.

X-Ray structure and crystal data of **170**:

Orthorhombic; space group: P 21 21 21; cell dimensions: $a = 6.1755(3) \text{ \AA}$, $\alpha = 90^\circ$, $b = 12.6779(6) \text{ \AA}$, $\beta = 90^\circ$, $c = 30.4159(11) \text{ \AA}$, $\gamma = 90^\circ$; $V = 2381.33(18) \text{ \AA}^3$; $Z = 4$, $D_x = 1.393 \text{ Mg/m}^3$; $\mu = 2.682 \text{ mm}^{-1}$; $F(000) = 1040$. Data collection: $T = 123 \text{ K}$; graphite monochromator. A colorless crystal with dimensions of $0.480 \times 0.040 \times 0.030 \text{ mm}$ was used to measure 7259 reflections (3553 unique reflections, $R_{\text{int}} = 0.0616$) from 3.78° to 62.35° on a Oxford Diffraction Gemini Ultra diffractometer with the omega-scan method. Structure refinement: The F^2 value was refined using the full-matrix least squares refinement method, with a goodness-of-fit of 1.005 for all reflections and 286 parameters.

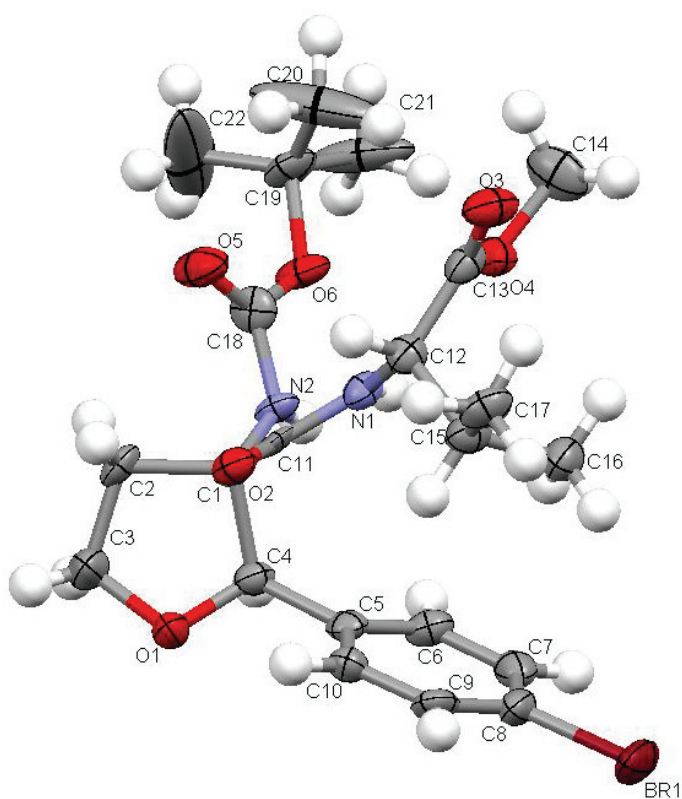

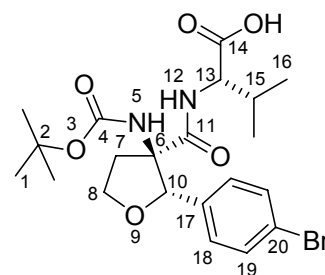

(S)-2-((2S,3R)-2-(4-Bromophenyl)-3-(tert-butoxycarbonylamino)-tetrahydrofuran-3-carboxamido)-3-methylbutanoic acid (**181**):

Compound **167** (440 mg, 0.88 mmol) was dissolved in 22 ml of a MeCN:water mixture (4:1, 25 ml/mmol). To the solution 1M aqueous LiOH (970 μ l, 0.97 mmol) was added drop by drop. The mixture was stirred over night at room temperature. After acidification with 1M aqueous KHSO₄ solution the mixture was extracted with DCM (3x10 ml). The combined organic layers were dried over MgSO₄ and concentrated under reduced pressure to give the product as colorless solid 93 % yield. (400 mg, 0.82 mmol)

MP 133-135 °C. – **¹H-NMR** (300 MHz, CDCl₃): δ = 0.44 (d, ³J_{H,H} = 5.2, 3 H, 16), 0.62 (d, ³J_{H,H} = 5.8, 3 H, 16), 1.42 (m, 9 H, 1), 1.78-1.95 (m, 1 H, 15), 2.41-2.65 (m, 1 H, 7), 2.67-2.86 (m, 1 H, 7), 4.13-4.39 (m, 3 H, 8 + 13), 5.39 (bs, 1 H, 10), 6.17 (bs, 1 H, NH), 6.47 (d, ³J_{H,H} = 7.7, 1 H, NH), 7.20 (d, ³J_{H,H} = 8.2, 2 H, 18), 7.35 (d, ³J_{H,H} = 8.8, 2 H, 19). – **¹³C-NMR** (75 MHz, CDCl₃): δ = 17.2 (+, 1 C, 16), 18.4 (+, 1 C, 16), 28.4 (+, 3 C, 1), 30.7 (-, 1 C, 15), 36.0 (-, 1 C, 7), 57.2 (+, 1 C, 13), 66.5 (-, 1 C, 8), 67.5 (C_{quat}, 1 C, 6), 80.2 (+, 1 C, 10), 80.3 (C_{quat}, 1 C, 2), 121.6 (C_{quat}, 1 C, 20), 127.0 (+, 2 C, 18), 131.4 (+, 2 C, 19), 136.4 (C_{quat}, 1 C, 17), 154.3 (C_{quat}, 1 C, 4), 171.4 (C_{quat}, 1 C, 11), 176.3 (C_{quat}, 1 C, 14). – **MS** (ES, DCM/MeOH + 10 mmol/l NH₄OAc): *m/z* (%) = 485.1 (100) [MH⁺], 502.2 (57) [MNH₄⁺], 523.1 (26) [MK⁺], 1007.3 (22) [2M + K⁺]; 409.0 (35) [M – ^tBuOH - H⁺], 483.1 (100) [M – H⁺]. – **IR** (neat) [cm⁻¹]: $\tilde{\nu}$ = 3397, 3334, 2967, 2891, 1734, 1710, 1667, 1492, 1256, 1164, 1067, 1044, 1010, 827, 793. – **MF** C₂₁H₂₉BrN₂O₆. – **MW** 485.37.

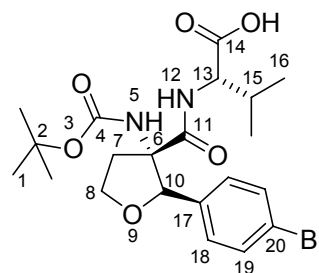

(S)-2-((2R,3S)-2-(4-Bromophenyl)-3-(tert-butoxycarbonylamino)-tetrahydrofuran-3-carboxamido)-3-methylbutanoic acid (183):

Compound **170** (300 mg, 0.60 mmol) was dissolved in 15 ml of a MeCN:water mixture (4:1, 25 ml/mmol). To the solution 1M aqueous LiOH (660 μ l, 0.66 mmol) was added drop by drop. The mixture was stirred over night at room temperature. After acidification with 1M aqueous KHSO₄ solution the mixture was extracted with DCM (3x8 ml). The combined organic layers were dried over MgSO₄ and concentrated under reduced pressure to give the product as colorless solid 96 % yield. (280 mg, 0.58 mmol)

MP 118-119 °C. – **¹H-NMR** (300 MHz, MeOH-*d*₄): δ = 0.62 (d, ³J_{H,H} = 8.2, 3 H, 14), 0.64 (d, ³J_{H,H} = 8.0, 3 H, 14), 1.78 (sextet, ³J_{H,H} = 6.7, 1 H, 13), 2.36 (ddd, ³J_{H,H} = 2.5, ³J_{H,H} = 7.3, ²J_{H,H} = 14.4, 1 H, 3), 3.00 (dt, ³J_{H,H} = 14.4, ³J_{H,H} = 9.3, 1 H, 1 H, 3), 3.67 (s, 3 H, 12), 3.84 (d, ³J_{H,H} = 6.6, 1 H, 9), 4.18 (dt, ³J_{H,H} = 7.2, ³J_{H,H} = 9.3, 1 H, 4), 4.54 (dt, ³J_{H,H} = 2.5, ³J_{H,H} = 9.1, 1 H, 4), 4.99 (s, 1 H, 6), 7.32 (d, ³J_{H,H} = 8.2, 2 H, 16), 7.53 (d, ³J_{H,H} = 8.8, 2 H, 17). – **¹³C-NMR** (75 MHz, MeOH-*d*₄): δ = 19.1 (+, 1 C, 14), 19.4 (+, 1 C, 14), 31.1 (+, 1 C, 13), 36.0 (-, 1 C, 3), 52.6 (+, 1 C, 12), 60.6 (+, 1 C, 9), 67.8 (-, 1 C, 4), 70.0 (C_{quat}, 1 C, 2), 86.8 (+, 1 C, 10), 123.8 (C_{quat}, 1 C, 18), 129.2 (+, 2 C, 16), 132.8 (+, 2 C, 17), 136.2 (C_{quat}, 1 C, 15), 169.2 (C_{quat}, 1 C, 7), 173.3 (C_{quat}, 1 C, 10). – **MS** (ES, DCM/MeOH + 10 mmol/l NH₄OAc): *m/z* (%) = 399.1 (100) [MH⁺]. – **IR** (neat) [cm⁻¹]: $\tilde{\nu}$ = 3394, 2960, 2362, 2341, 1723, 1672, 1509, 1437, 1213, 1145, 1070, 1010, 830, 703. – **MF** C₂₁H₂₉BrN₂O₆. – **MW** 485.37.

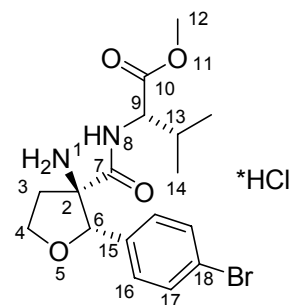

(S)-Methyl 2-((2S,3R)-3-amino-2-(4-bromophenyl)-tetrahydrofuran-3-carboxamido)-3-methylbutanoate (182):

Compound **167** (290 mg, 0.58 mmol) was dissolved under ice bath cooling at 0 °C in diethyl ether. To this solution 4.1 ml ice cold HCl saturated ether (7 ml/mmol Boc) was added and the mixture was stirred over night at room temperature. The solvent was removed under reduced pressure to give the HCl salt of the product as white hygroscopic solid in quantitative yield (250 mg, 0.57 mmol). No further purification was necessary.

MP > 180 °C. – **¹H-NMR** (300 MHz, MeOH-*d*₄): δ = 0.62 (d, ³J_{H,H} = 8.2, 3 H, 14), 0.64 (d, ³J_{H,H} = 8.0, 3 H, 14), 1.78 (sextet, ³J_{H,H} = 6.7, 1 H, 13), 2.36 (ddd, ³J_{H,H} = 2.5, ³J_{H,H} = 7.3, ²J_{H,H} = 14.4, 1 H, 3), 3.00 (dt, ³J_{H,H} = 14.4, ³J_{H,H} = 9.3, 1 H, 1 H, 3), 3.67 (s, 3 H, 12), 3.84 (d, ³J_{H,H} = 6.6, 1 H, 9), 4.18 (dt, ³J_{H,H} = 7.2, ³J_{H,H} = 9.3, 1 H, 4), 4.54 (dt, ³J_{H,H} = 2.5, ³J_{H,H} = 9.1, 1 H, 4), 4.99 (s, 1 H, 6), 7.32 (d, ³J_{H,H} = 8.2, 2 H, 16), 7.53 (d, ³J_{H,H} = 8.8, 2 H, 17). – **¹³C-NMR** (75 MHz, MeOH-*d*₄): δ = 19.1 (+, 1 C, 14), 19.4 (+, 1 C, 14), 31.1 (+, 1 C, 13), 36.0 (-, 1 C, 3), 52.6 (+, 1 C, 12), 60.6 (+, 1 C, 9), 67.8 (-, 1 C, 4), 70.0 (C_{quat}, 1 C, 2), 86.8 (+, 1 C, 10), 123.8 (C_{quat}, 1 C, 18), 129.2 (+, 2 C, 16), 132.8 (+, 2 C, 17), 136.2 (C_{quat}, 1 C, 15), 169.2 (C_{quat}, 1 C, 7), 173.3 (C_{quat}, 1 C, 10). – **MS** (ES, DCM/MeOH + 10 mmol/l NH₄OAc): *m/z* (%) = 399.1 (100) [MH⁺]. – **IR** (neat) [cm⁻¹]: $\tilde{\nu}$ = 3288, 2965, 2874, 2362, 2341, 1749, 1684, 1646, 1519, 1488, 1157, 1074, 1010, 841. – **MF** C₁₇H₂₃BrN₂O₄*HCl. – **MW** 435.74.

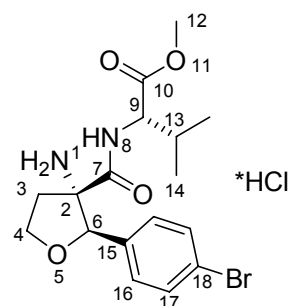

(S)-Methyl 2-((2R,3S)-3-amino-2-(4-bromophenyl)-tetrahydrofuran-3-carboxamido)-3-methyl-butanoate (184):

Compound **170** (300 mg, 0.60 mmol) was dissolved under ice bath cooling at 0 °C in diethyl ether. To this solution 4.2 ml ice cold HCl saturated ether (7 ml/mmol Boc) was added and the mixture was stirred over night at room temperature. The solvent was removed under reduced pressure to give the HCl salt of the product as white hygroscopic solid in quantitative yield (260 mg, 0.60 mmol). No further purification was necessary.

MP >180 °C. – **¹H-NMR** (300 MHz, MeOH-*d*₄): δ = 0.85 (t, ³J_{H,H} = 6.9, 6 H, 14), 2.02 (sextet, ³J_{H,H} = 6.8, 1 H, 13), 2.40-2.51 (m, 1 H, 3), 2.93 (dt, ²J_{H,H} = 14.4, ³J_{H,H} = 9.0, 1 H, 3), 3.67 (s, 3 H, 12), 4.03 (d, ³J_{H,H} = 7.1, 1 H, 9), 4.21 (q, ³J_{H,H} = 8.3, 1 H, 4), 4.53 (t, ³J_{H,H} = 8.9, 1 H, 4), 5.02 (s, 1 H, 6), 7.29 (d, ³J_{H,H} = 8.2, 2 H, 16), 7.45 (d, ³J_{H,H} = 8.5, 2 H, 17). – **¹³C-NMR** (75 MHz, MeOH-*d*₄): δ = 18.9 (+, 1 C, 14), 19.4 (+, 1 C, 14), 32.6 (+, 1 C, 13), 36.2 (-, 1 C, 3), 52.8 (+, 1 C, 12), 59.5 (+, 1 C, 9), 67.8 (-, 1 C, 4), 69.8 (C_{quat}, 1 C, 2), 87.0 (+, 1 C, 10), 123.7 (C_{quat}, 1 C, 18), 129.4 (+, 2 C, 16), 132.5 (+, 2 C, 17), 135.3 (C_{quat}, 1 C, 15), 168.8 (C_{quat}, 1 C, 7), 172.4 (C_{quat}, 1 C, 10). – **MS** (ES, DCM/MeOH + 10 mmol/l NH₄OAc): *m/z* (%) = 399.1 (100) [MH⁺]. – **IR** (neat) [cm⁻¹]: $\tilde{\nu}$ = 3399, 2957, 2526, 2362, 2341, 1723, 1672, 1509, 1488, 1437, 1212, 1069, 1009, 829, 803. – **MF** C₁₇H₂₃BrN₂O₄*HCl. – **MW** 435.74.

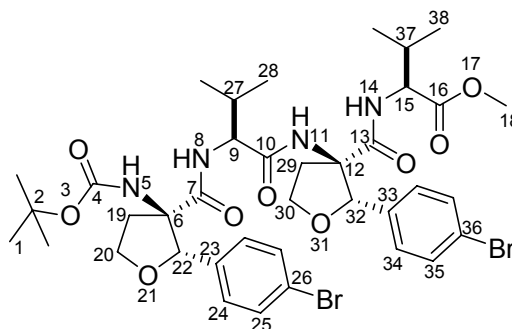

(S)-Methyl 2-((2S,3R)-2-(4-bromophenyl)-3-((S)-2-((2S,3R)-2-(4-bromophenyl)-3-(tert-butoxycarbonylamino)-tetrahydrofuran-3-carboxamido)-3-methylbutanamido)-tetrahydrofuran-3-carbox-amido)-3-methylbutanoate (**168**):

Under an atmosphere of nitrogen compound **181** (150 mg, 0.31 mmol, 1 eq.) was dissolved in 2.5 ml DMF (8 ml/mmol) and cooled to 0 °C in an ice bath. To the solution DIPEA (159 μ l, 0.93 mmol, 3 eq.), HOAt (64 mg, 0.46 mmol, 1.5 eq.) and HATU (176 mg, 0.46 mmol, 1.5 eq.) were added in this sequence. Then the amine **182** (148 mg, 0.34 mmol, 1.1 eq.) was slowly added in portions. The mixture was allowed to warm to room temperature and stirred for 24 hours. The reaction was quenched with 2 ml of water and 1 ml of 1M aqueous KHSO₄ and extracted with diethyl ether (3x10 ml). The combined organic layers were washed twice with brine. Afterwards the solution was dried over MgSO₄ and concentrated under reduced pressure. The crude product was then purified by column chromatography on flash silica gel (PE:diethyl ether 60:40, R_f = 0.14) to give the product as colorless solids with an overall yield of 67 % (180 mg, 0.21 mmol).

MP 159-161 °C. – **¹H-NMR** (600 MHz, COSY, CDCl₃): δ = 0.65 (d, ³J_{H,H} = 6.8, 3 H, 38), 0.67 (d, ³J_{H,H} = 7.2, 3 H, 28), 0.74 (d, ³J_{H,H} = 6.6, 3 H, 38), 0.81 (d, ³J_{H,H} = 6.8, 3 H, 28), 1.48 (s, 9 H, 1), 1.91-1.99 (m, 1 H, 37), 2.00-2.06 (m, 1 H, 27), 2.46-2.61 (m, 2 H, 19 + 29), 2.82-2.91 (m, 1 H, 29), 3.15 (bs, 1 H, 19), 3.59-70 (m, 4 H, 9 + 18), 3.98-4.08 (m, 1 H, 30), 4.16 (dd, ³J_{H,H} = 5.5, ³J_{H,H} = 8.8, 1 H, 15), 4.23 (dd, ³J_{H,H} = 8.7, ³J_{H,H} = 15.7, 1 H, 20), 4.33 (dt, ³J_{H,H} = 2.8, ³J_{H,H} = 8.5, 1 H, 30), 4.43 (dt, ³J_{H,H} = 5.3, ³J_{H,H} = 8.6, 1 H, 20), 5.00 (s, 1 H, 22), 5.21 (s, 1 H, 32), 5.84 (s, 1H 5), 6.32 (s, 1H, 8), 6.87 (d, ³J_{H,H} = 7.7, 1 H, 14), 7.14 (d, ³J_{H,H} = 8.4, 2 H, 24), 7.17 (d, ³J_{H,H} = 8.6, 2 H, 34), 7.28 (d, ³J_{H,H} = 7.9, 2 H, 25), 7.35 (d, ³J_{H,H} = 8.4, 2 H, 35), 7.48 (s, 1 H, 11). – **¹³C-NMR** (150 MHz, HSQC, HMBC, CDCl₃): δ = 17.4 (+, 1 C, 28), 17.7 (+, 1 C, 38), 18.7 (+, 1 C, 38), 19.0 (+, 1 C, 28), 28.4 (+, 3 C, 1), 30.0 (+, 1 C, 27), 31.2 (+, 1 C, 37), 35.5 (-, 1 C, 29), 35.6 (-, 1 C, 19), 51.8 (+, 1 C, 18), 57.5 (+, 1 C, 15), 59.7 (+, 1 C, 9), 67.4 (-, 1 C, 30), 67.6 (-, 1 C, 20), 69.0 (C_{quat}, 1 C, 6), 69.6 (C_{quat}, 1 C, 12), 81.7 (C_{quat}, 1 C, 2), 83.8 (+, 1 C, 32), 84.3 (+, 1 C, 22), 121.7 (C_{quat}, 1 C, 36), 122.6 (C_{quat}, 1 C, 26), 127.7 (+, 2 C, 24), 127.9 (+, 2 C, 34), 131.0 (+, 2 C, 35), 131.4 (+, 2 C, 25), 135.1 (C_{quat}, 1 C, 23), 136.6 (C_{quat}, 1 C, 33), 155.5 (C_{quat}, 1 C, 4), 189.7 (C_{quat}, 1 C, 13), 169.9 (C_{quat}, 1 C, 10), 171.0 (C_{quat}, 1 C, 7), 171.8 (C_{quat}, 1 C, 16). –

MS (ES, DCM/MeOH + 10 mM NH₄OAc): m/z (%) = 867.3 (100) [MH⁺], 884.3 (74) [MNH₄⁺]; 865.3 (100) [M - H⁺], 925.3 (55) [M + OAc⁻]. – **HR-MS** (PI-LSIMS, MeOH/DCM/NBA): [MH⁺] calcd. for C₃₈H₅₀Br₂N₄O₉ 865.2023; found 865.2022. – **IR** (neat) [cm⁻¹]: $\tilde{\nu}$ = 3252, 3312, 3241, 2964, 2941, 2884, 2361, 2341, 1736, 1668, 1595, 1519, 1463, 1259, 1118, 1010, 994, 829. – **MF** C₃₈H₅₀Br₂N₄O₉. – **MW** 866.63.

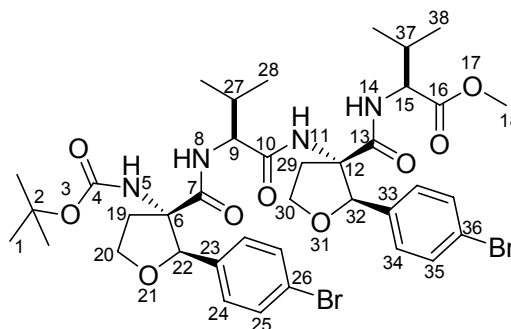

(S)-Methyl 2-((2R,3S)-2-(4-bromophenyl)-3-((S)-2-((2R,3S)-2-(4-bromophenyl)-3-(tert-butoxycarbonylamino)-tetrahydrofuran-3-carboxamido)-3-methylbutanamido)-tetrahydrofuran-3-carbox-amido)-3-methylbutanoate (171):

Under an atmosphere of nitrogen compound **183** (180 mg, 0.37 mmol, 1 eq.) was dissolved in 3.0 ml DMF (8 ml/mmol) and cooled to 0 °C in an ice bath. To the solution DIPEA (190 μ l, 1.11 mmol, 3 eq.), HOAt (76 mg, 0.56 mmol, 1.5 eq.) and HATU (212 mg, 0.56 mmol, 1.5 eq.) were added in this sequence. Then the amine **184** (178 mg, 0.41 mmol, 1.1 eq.) was slowly added in portions. The mixture was allowed to warm to room temperature and stirred for 24 hours. The reaction was quenched with 2 ml of water and 1 ml of 1M aqueous KHSO₄ and extracted with diethyl ether (3x10 ml). The combined organic layers were washed twice with brine. Afterwards the solution was dried over MgSO₄ and concentrated under reduced pressure. The crude product was then purified by column chromatography on flash silica gel (PE:diethyl ether 50:50, R_f = 0.13) to give the product as colorless solids with an overall yield of 56 % (180 mg, 0.21 mmol).

MP 148-149 °C. – **¹H-NMR** (600 MHz, COSY, MeOH-*d*₄): δ = 0.65 (d, ³J_{H,H} = 7.1, 3 H, 28), 0.66 (d, ³J_{H,H} = 7.0, 3 H, 38), 0.73 (d, ³J_{H,H} = 7.0, 3 H, 38), 0.82 (d, ³J_{H,H} = 7.0, 3 H, 28), 1.51 (s, 9 H, 1), 1.64 (sextet, ³J_{H,H} = 6.8, 1 H, 37), 1.92-1.99 (m, 1 H, 27), 2.17-2.24 (m, 2 H, 19 + 29), 3.09 (ddd, ³J_{H,H} = 8.4, ³J_{H,H} = 10.4, ²J_{H,H} = 13.3, 29), 3.25-3.32 (m, 2 H, 9 + 19), 3.42 (d, ³J_{H,H} = 6.4, 1 H, 15), 3.59 (s, 3 H, 18), 3.70-3.76 (m, 1 H, 30), 4.09 (q, ³J_{H,H} = 8.1, 1 H, 20), 4.26 (dt, ³J_{H,H} = 2.4, ³J_{H,H} = 8.3, 1 H, 30), 4.34 (dt, ³J_{H,H} = 4.5, ³J_{H,H} = 8.4, 1 H, 20), 4.89 (s, 1 H, 22), 5.14 (s, 1 H, 32), 7.26 (d, ³J_{H,H} = 8.3, 2 H, 24), 7.37 (d, ³J_{H,H} = 8.6, 2 H, 34), 7.39 (d, ³J_{H,H} = 8.8, 2 H, 35), 7.47 (d, ³J_{H,H} = 8.6, 2 H, 25). – **¹³C-NMR** (150 MHz, HSQC, HMBC, MeOH-*d*₄): δ = 17.9 (+, 1 C, 28), 19.0 (+, 1 C, 38), 19.2 (+, 1 C, 28),

19.7 (+, 1 C, 38), 28.7 (+, 3 C, 1), 30.5 (+, 1 C, 27), 31.2 (+, 1 C, 37), 37.8 (-, 1 C, 29), 38.0 (-, 1 C, 19), 52.0 (+, 1 C, 18), 60.9 (+, 1 C, 15), 61.8 (+, 1 C, 9), 68.8 (-, 2 C, 20 + 30), 72.0 (C_{quat}, 1 C, 6), 72.4 (C_{quat}, 1 C, 12), 82.6 (C_{quat}, 1 C, 2), 86.9 (+, 1 C, 22), 88.2 (+, 1 C, 32), 123.2 (C_{quat}, 1 C, 36), 123.7 (C_{quat}, 1 C, 26), 129.9 (+, 2 C, 24), 130.6 (+, 2 C, 34), 131.9 (+, 2 C, 35), 132.4 (+, 2 C, 25), 138.0 (C_{quat}, 1 C, 23), 138.4 (C_{quat}, 1 C, 33), 158.9 (C_{quat}, 1 C, 4), 172.0 (C_{quat}, 1 C, 13), 172.7 (C_{quat}, 1 C, 10), 172.8 (C_{quat}, 1 C, 16), 173.3 (C_{quat}, 1 C, 7). – **¹H-NMR** (600 MHz, COSY, DMSO-*d*₆): δ = 0.58 (d, ³J_{H,H} = 6.8, 6 H, 28 + 38), 0.66 (d, ³J_{H,H} = 6.9, 3 H, 38), 0.73 (d, ³J_{H,H} = 6.9, 3 H, 28), 1.43 (s, 9 H, 1), 1.55 (octet, ³J_{H,H} = 6.8, 1 H, 37), 1.86 (bs, 1 H, 27), 2.06-2.16 (m, 2 H, 19 + 29), 2.85 (q, ³J_{H,H} = 10.6, 1 H, 29), 3.05 (dt, ²J_{H,H} = 12.6, ³J_{H,H} = 8.6, 1 H, 19), 3.17 (s, 1 H, 9), 3.20 (t, ³J_{H,H} = 6.1, 1 H, 15), 3.46 (s, 3 H, 18), 3.60 (dd, ³J_{H,H} = 7.3, ²J_{H,H} = 17.0, 30), 3.94 (q, ³J_{H,H} = 7.9, 1 H, 20), 4.19 (t, ³J_{H,H} = 7.7, 1 H, 30), 4.22 (dt, ³J_{H,H} = 3.9, ³J_{H,H} = 8.3, 1 H, 20), 5.02 (s, 1 H, 22), 5.03 (s, 1 H, 32), 7.14 (d, ³J_{H,H} = 6.2, 2 H, 14), 7.18 (d, ³J_{H,H} = 2.6, 2 H, 8), 7.25 (d, ³J_{H,H} = 8.1, 2 H, 34), 7.26 (d, ³J_{H,H} = 6.4, 2 H, 24), 7.42 (d, ³J_{H,H} = 8.3, 2 H, 35), 7.47 (d, ³J_{H,H} = 8.3, 2 H, 25), 7.76 (s, 1 H, 11), 8.15 (s, 1 H, 5). – **¹³C-NMR** (150 MHz, HSQC, HMBC, DMSO-*d*₆): δ = 17.9 (+, 1 C, 28), 18.6 (+, 1 C, 38), 18.7 (+, 1 C, 28), 19.3 (+, 1 C, 38), 28.4 (+, 3 C, 1), 29.2 (+, 1 C, 27), 29.8 (+, 1 C, 37), 35.9 (-, 1 C, 29), 36.6 (-, 1 C, 19), 51.5 (+, 1 C, 18), 59.2 (+, 1 C, 15), 60.3 (+, 1 C, 9), 67.5 (-, 2 C, 20 + 30), 70.7 (C_{quat}, 1 C, 6), 70.8 (C_{quat}, 1 C, 12), 80.5 (C_{quat}, 1 C, 2), 84.9 (+, 1 C, 22), 86.5 (+, 1 C, 32), 121.5 (C_{quat}, 1 C, 36), 121.7 (C_{quat}, 1 C, 26), 129.4 (+, 2 C, 24), 129.6 (+, 2 C, 34), 130.7 (+, 2 C, 35), 131.0 (+, 2 C, 25), 137.5 (C_{quat}, 1 C, 23), 138.0 (C_{quat}, 1 C, 33), 156.8 (C_{quat}, 1 C, 4), 169.7 (C_{quat}, 1 C, 13), 170.4 (C_{quat}, 1 C, 10), 171.2 (C_{quat}, 1 C, 16), 171.8 (C_{quat}, 1 C, 7). – **MS** (ES, DCM/MeOH + 10 mM NH₄OAc): *m/z* (%) = 867.2 (100) [MH⁺], 884.3 (24) [MNH₄⁺]. – **HR-MS** (PI-LSIMS, MeOH/DCM/NBA): [MH⁺] calcd. for C₃₈H₅₀Br₂N₄O₉ 865.2023; found 865.2026. – **IR** (neat) [cm⁻¹]: $\tilde{\nu}$ = 3249, 3312, 3242, 2967, 2941, 2879, 2360, 2341, 1736, 1672, 1594, 1519, 1465, 1256, 1111, 1010, 997, 831. – **MF** C₃₈H₅₀Br₂N₄O₉. – **MW** 866.63.

X-Ray structure and crystal data of **171**:

Orthorhombic; space group: P 21 21 21; cell dimensions: $a = 10.14170(10) \text{ \AA}$, $\alpha = 90^\circ$, $b = 16.2309(2) \text{ \AA}$, $\beta = 90^\circ$, $c = 27.0320(4) \text{ \AA}$, $\gamma = 90^\circ$; $V = 4449.71(10) \text{ \AA}^3$; $Z = 4$, $D_x = 1.389 \text{ Mg/m}^3$; $\mu = 2.811 \text{ mm}^{-1}$; $F(000) = 1936$. Data collection: $T = 123 \text{ K}$; graphite monochromator. A colorless crystal with dimensions of $0.420 \times 0.360 \times 0.230 \text{ mm}$ was used to measure 15559 reflections (6662 unique reflections, $R_{\text{int}} = 0.0341$) from 3.18° to 62.13° on a Oxford Diffraction Gemini Ultra diffractometer with the omega-scan method. Structure refinement: The F^2 value was refined using the full-matrix least squares refinement method, with a goodness-of-fit of 1.024 for all reflections and 550 parameters.

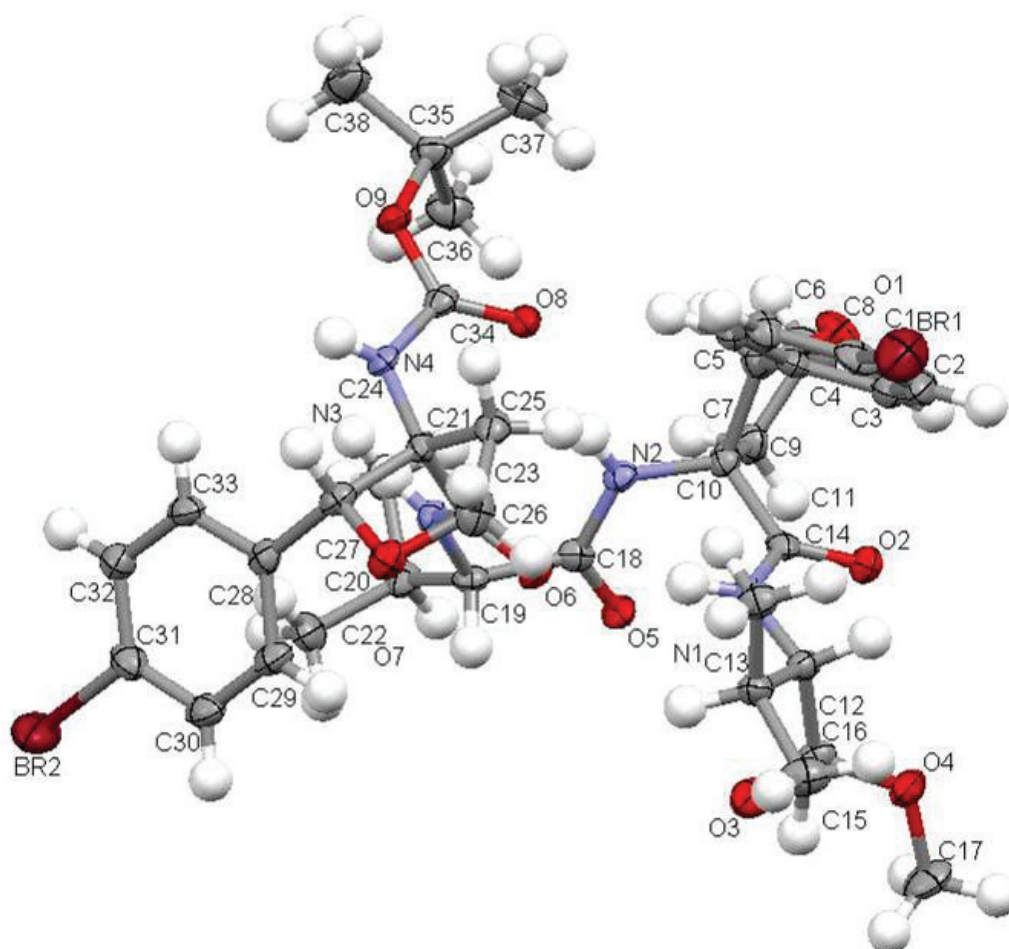

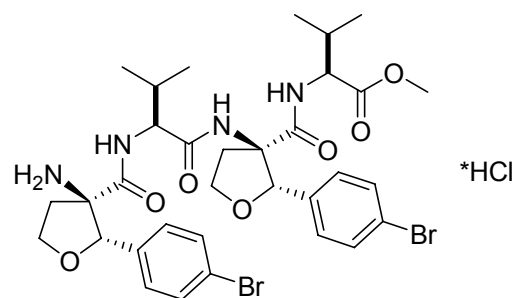

(S)-Methyl 2-((2S,3R)-3-((S)-2-((2S,3R)-3-amino-2-(4-bromophenyl)-tetrahydrofuran-3-carboxamido)-3-methylbutanamido)-2-(4-bromophenyl)-tetrahydrofuran-3-carboxamido)-3-methylbutanoate · HCl (167):

Compound **167** (260 mg, 0.33 mmol) was dissolved under ice bath cooling at 0 °C in dichloromethane. To this solution 2.3 ml ice cold HCl saturated ether (7 ml/mmol Boc) was added and the mixture was stirred over night at room temperature. The solvent was removed under reduced pressure to give the HCl salt of the product as white hygroscopic solid in quantitative yield (240 mg, 0.31 mmol). No further purification was necessary.

MP > 180 °C. – **¹H-NMR** (300 MHz, MeOH-*d*₄): δ = 0.67 (d, ³J_{H,H} = 6.9, 3 H, Val-CH₃), 0.72 (d, ³J_{H,H} = 6.9, 3 H, Val-CH₃), 0.93 (d, ³J_{H,H} = 7.1, 3 H, Val-CH₃), 0.96 (d, ³J_{H,H} = 6.9, 3 H, Val-CH₃), 1.82 (septet, ³J_{H,H} = 6.4, 1 H, Val-CH), 2.09 (septet, ³J_{H,H} = 6.4, 1 H, Val-CH), 2.21 (ddd, ³J_{H,H} = 3.2, ³J_{H,H} = 7.5, ²J_{H,H} = 12.8, 1 H, CH₂), 2.44-2.59 (m, 1 H, CH₂), 2.97 (dt, ²J_{H,H} = 13.3, ³J_{H,H} = 8.6, 2 H, CH₂), 3.67 (s, 3 H, OCH₃), 3.83 (d, ³J_{H,H} = 5.8, 1 H, CHNH), 4.02 (q, ³J_{H,H} = 8.2, 1 H, CHNH), 4.12 (d, ³J_{H,H} = 5.5, 1 H, OCH₂), 4.24 (q, ³J_{H,H} = 8.4, 1 H, OCH₂), 4.36 (dt, ³J_{H,H} = 3.1, ³J_{H,H} = 8.4, 1 H, OCH₂), 4.48 (dt, ³J_{H,H} = 2.4, ³J_{H,H} = 8.2, 1 H, OCH₂), 5.09 (s, 1 H, OCH), 5.13 (s, 1 H, OCH), 7.24 (d, ³J_{H,H} = 8.2, 2 H, Ar-CH), 7.31 (d, ³J_{H,H} = 8.5, 2 H, Ar-CH), 7.38 (d, ³J_{H,H} = 8.8, 4 H, Ar-CH). – **¹³C-NMR** (75 MHz, MeOH-*d*₄): δ = 18.7 (+, 1 C, Val-CH₃), 18.9 (+, 1 C, Val-CH₃), 19.2 (+, 1 C, Val-CH₃), 20.2 (+, 1 C, Val-CH₃), 32.9 (+, 1 C, Val-CH), 33.1 (+, 1 C, Val-CH), 37.0 (-, 2 C, CH₂), 52.9 (+, 1 C, OCH₃), 59.3 (+, 1 C, CHNH), 60.3 (+, 1 C, CHNH), 67.6 (-, 1 C, OCH₂), 68.7 (-, 1 C, OCH₂), 69.3 (C_{quat}, 1 C, CNH), 71.6 (C_{quat}, 1 C, CNH), 85.9 (+, 1 C, OCH), 86.4 (+, 1 C, OCH), 123.1 (C_{quat}, 1 C, CBr), 123.8 (C_{quat}, 1 C, CBr), 129.6 (+, 2 C, Ar-CH), 129.7 (+, 2 C, Ar-CH), 132.3 (+, 2 C, Ar-CH), 132.6 (+, 2 C, Ar-CH), 135.1 (C_{quat}, 1 C, Ar-C), 138.1 (C_{quat}, 1 C, Ar-C), 168.9 (C_{quat}, 1 C, CO), 171.3 (C_{quat}, 1 C, CO), 172.8 (C_{quat}, 1 C, CO), 173.0 (C_{quat}, 1 C, CO). – **MS** (ES, DCM/MeOH + 10 mmol/l NH₄OAc): *m/z* (%) = 765.2 (100) [MH⁺]; 799.1 (100) [M + Cl]. – **IR** (neat) [cm⁻¹]: $\tilde{\nu}$ = 3289, 2965, 2872, 2362, 2342, 1749, 1681, 1646, 1519, 1483, 1157, 1074, 1007, 841. – **MF** C₃₃H₄₂Br₂N₄O₇*HCl. – **MW** 802.98.

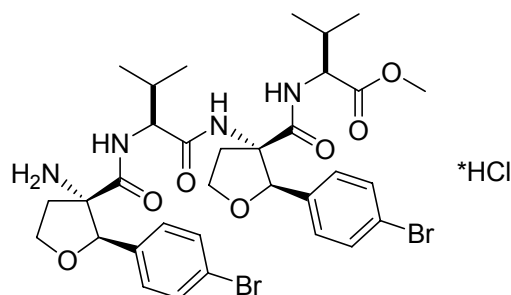

(S)-Methyl 2-((2R,3S)-3-((S)-2-((2R,3S)-3-amino-2-(4-bromophenyl)-tetrahydrofuran-3-carboxamido)-3-methylbutanamido)-2-(4-bromophenyl)-tetrahydrofuran-3-carboxamido)-3-methylbutanoate · HCl (186):

Compound **170** (130 mg, 0.15 mmol) was dissolved under ice bath cooling at 0 °C in dichloromethane. To this solution 1.1 ml ice cold HCl saturated ether (7 ml/mmol Boc) was added and the mixture was stirred over night at room temperature. The solvent was removed under reduced pressure to give the HCl salt of the product as white hygroscopic solid in quantitative yield (120 mg, 0.15 mmol). No further purification was necessary.

MP > 180 °C. – **¹H-NMR** (300 MHz, MeOH-*d*₄): δ = 0.70 (d, ³J_{H,H} = 6.9, 3 H, Val-CH₃), 0.81 (d, ³J_{H,H} = 6.9, 3 H, Val-CH₃), 0.93 (d, ³J_{H,H} = 6.6, 3 H, Val-CH₃), 0.97 (d, ³J_{H,H} = 6.6, 3 H, Val-CH₃), 1.74 (octet, ³J_{H,H} = 6.5, 1 H, Val-CH), 2.13 (q, ³J_{H,H} = 5.8, 1 H, Val-CH), 2.34 (dd, ³J_{H,H} = 5.8, ²J_{H,H} = 12.9, 1 H, CH₂), 2.45-2.61 (m, 1 H, CH₂), 2.75-3.04 (m, 2 H, CH₂), 3.61 (s, 3 H, OCH₃), 3.81-3.90 (m, 1 H, CHNH), 4.02 (q, ³J_{H,H} = 7.9, 1 H, CHNH), 4.15 (d, ³J_{H,H} = 5.5, 1 H, OCH₂), 4.22 (q, ³J_{H,H} = 8.0, 1 H, OCH₂), 4.39 (t, ³J_{H,H} = 8.4, 1 H, OCH₂), 4.49 (t, ³J_{H,H} = 6.6, 1 H, OCH₂), 5.04 (s, 1 H, OCH), 5.12 (s, 1 H, OCH), 7.21 (d, ³J_{H,H} = 8.2, 2 H, Ar-CH), 7.30 (d, ³J_{H,H} = 8.2, 2 H, Ar-CH), 7.39 (d, ³J_{H,H} = 3.8, 2 H, Ar-CH), 7.42 (d, ³J_{H,H} = 3.6, 2 H, Ar-CH). – **¹³C-NMR** (75 MHz, MeOH-*d*₄): δ = 18.6 (+, 1 C, Val-CH₃), 19.1 (+, 1 C, Val-CH₃), 19.2 (+, 1 C, Val-CH₃), 20.1 (+, 1 C, Val-CH₃), 32.4 (+, 1 C, Val-CH), 33.3 (+, 1 C, Val-CH), 36.1 (-, 1 C, CH₂), 36.8 (-, 1 C, CH₂), 52.7 (+, 1 C, OCH₃), 59.5 (+, 1 C, CHNH), 60.0 (+, 1 C, CHNH), 67.4 (-, 1 C, OCH₂), 68.6 (-, 1 C, OCH₂), 69.1 (C_{quat}, 1 C, CNH), 71.8 (C_{quat}, 1 C, CNH), 86.1 (+, 1 C, OCH), 86.3 (+, 1 C, OCH), 123.1 (C_{quat}, 1 C, CBr), 123.9 (C_{quat}, 1 C, CBr), 129.6 (+, 2 C, Ar-CH), 129.8 (+, 2 C, Ar-CH), 132.2 (+, 2 C, Ar-CH), 132.7 (+, 2 C, Ar-CH), 134.9 (C_{quat}, 1 C, Ar-C), 138.3 (C_{quat}, 1 C, Ar-C), 168.8 (C_{quat}, 1 C, CO), 171.3 (C_{quat}, 1 C, CO), 172.6 (C_{quat}, 1 C, CO), 172.8 (C_{quat}, 1 C, CO). – **MS** (ES, DCM/MeOH + 10 mmol/l NH₄OAc): *m/z* (%) = 765.1 (100) [MH⁺]. – **IR** (neat) [cm⁻¹]: $\tilde{\nu}$ = 3401, 2957, 2526, 2361, 2341, 1727, 1672, 1513, 1488, 1436, 1212, 1069, 1005, 829, 802. – **MF** C₃₃H₄₂Br₂N₄O₇·HCl. – **MW** 802.98.

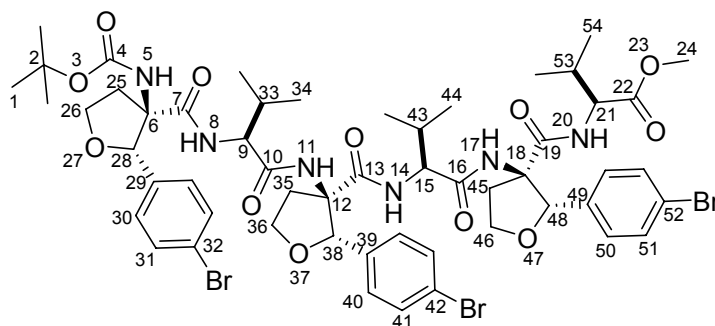

(S)-Methyl 2-((2S,3R)-2-(4-bromophenyl)-3-((S)-2-((2S,3R)-2-(4-bromophenyl)-3-((S)-2-((2S,3R)-2-(4-bromophenyl)-3-(tert-butoxycarbonylamino)-tetrahydrofuran-3-carboxamido)3-methylbutanamido)-tetrahydrofuran-3-carboxamido)-3-methylbutanoate (169):

Under an atmosphere of nitrogen compound **181** (73 mg, 0.15 mmol, 1.5 eq.) was dissolved in 1.5 ml DMF (10 ml/mmol) and cooled to 0 °C in an ice bath. To the solution DIPEA (75 μ l, 0.44 mmol, 4.4 eq.), HOAt (30 mg, 0.22 mmol, 2.2 eq.) and HATU (80 mg, 0.22 mmol, 2.2 eq.) were added in this sequence. Then the amine **185** (80 mg, 0.10 mmol, 1.0 eq.) was slowly added in portions. The mixture was allowed to warm to room temperature and stirred for 24 hours. The reaction was quenched with 2 ml of water and 0.5 ml of 1M aqueous KHSO_4 and extracted with diethyl ether (3x5 ml). The combined organic layers were washed twice with brine. Afterwards the solution was dried over MgSO_4 and concentrated under reduced pressure. The crude product was then purified by column chromatography on flash silica gel (PE:diethyl ether 50:50, $R_f = 0.21$) to give the product as colorless solids with an overall yield of 66 % (82 mg, 0.066 mmol).

MP 109-110 °C. – **$^1\text{H-NMR}$** (600 MHz, COSY, ROESY, CDCl_3): $\delta = 0.58$ (d, $^3J_{\text{H,H}} = 7.0$, 3 H, 34), 0.69 (d, $^3J_{\text{H,H}} = 7.0$, 3 H, 44), 0.76 (d, $^3J_{\text{H,H}} = 7.0$, 3 H, 34), 0.84 (d, $^3J_{\text{H,H}} = 6.8$, 3 H, 54), 0.86 (d, $^3J_{\text{H,H}} = 7.2$, 3 H, 44), 0.87 (d, $^3J_{\text{H,H}} = 7.0$, 3 H, 54), 1.52 (s, 9 H, 1), 1.98 (dq, $^3J_{\text{H,H}} = 3.5$, $^3J_{\text{H,H}} = 7.0$, 1 H, 33), 2.02-2.11 (m, 3 H, 35 + 43 + 53), 2.20 (ddd, $^3J_{\text{H,H}} = 5.2$, $^3J_{\text{H,H}} = 8.3$, $^2J_{\text{H,H}} = 13.0$, 1 H, 25), 2.37 (ddd, $^3J_{\text{H,H}} = 3.6$, $^3J_{\text{H,H}} = 6.2$, $^2J_{\text{H,H}} = 13.3$, 1 H, 45), 3.17-3.23 (m, 1 H, 45), 3.25 (t, $^3J_{\text{H,H}} = 4.5$, 1 H, 15), 3.32 (t, $^3J_{\text{H,H}} = 3.6$, 1 H, 9), 3.34 (dt, $^2J_{\text{H,H}} = 12.6$, $^3J_{\text{H,H}} = 7.6$, 1 H, 25), 3.59 (s, 3 H, 24), 3.62 (dt, $^2J_{\text{H,H}} = 13.2$, $^3J_{\text{H,H}} = 8.4$, 1 H, 35), 3.87-3.94 (m, 2 H, 36 + 46), 4.09 (dd, $^3J_{\text{H,H}} = 6.8$, $^3J_{\text{H,H}} = 9.0$, 1 H, 21), 4.17 (dd, $^3J_{\text{H,H}} = 8.4$, $^2J_{\text{H,H}} = 15.6$, 1 H, 26), 4.35 (dt, $^3J_{\text{H,H}} = 3.4$, $^3J_{\text{H,H}} = 8.1$, 1 H, 46), 4.39-4.47 (m, 2 H, 26 + 36), 4.75 (s, 1 H, 28), 5.07 (s, 1 H, 38), 5.19 (s, 1 H, 48), 5.88 (d, $^3J_{\text{H,H}} = 3.3$, 1 H, 8), 6.20 (s, 1 H, 5), 6.88 (d, $^3J_{\text{H,H}} = 4.2$, 1 H, 14), 7.16 (d, $^3J_{\text{H,H}} = 8.4$, 2 H, 30), 7.27 (d, $^3J_{\text{H,H}} = 7.5$, 2 H, 51), 7.30-7.38 (m, 7 H, 20 + 40 + 41 + 50), 7.45 (s, 1 H, 17), 7.49 (d, $^3J_{\text{H,H}} = 8.4$, 2 H, 31), 7.99 (s, 1 H, 11). – **$^{13}\text{C-NMR}$** (150 MHz, HSQC, HMBC, CDCl_3): $\delta = 16.5$ (+, 1 C, 44), 17.0 (+, 1 C, 34), 18.3 (+, 1 C, 54), 18.6 (+, 1 C, 44), 18.9 (+, 1 C, 34), 19.1

(+, 1 C, 54), 28.4 (+, 3 C, 1), 29.0 (+, 1 C, 33 + 43), 31.5 (+, 1 C, 53), 36.5 (-, 1 C, 45), 36.6 (-, 1 C, 25), 38.0 (-, 1 C, 35), 51.5 (+, 1 C, 24), 57.7 (+, 1 C, 21), 60.3 (+, 1 C, 9), 61.7 (+, 1 C, 15), 67.9 (-, 1 C, 26), 68.5 (-, 1 C, 46), 68.6 (-, 1 C, 36), 70.5 (C_{quat}, 1 C, 6), 70.9 (C_{quat}, 1 C, 12), 71.1 (C_{quat}, 1 C, 18), 83.0 (C_{quat}, 1 C, 2), 86.6 (+, 1 C, 38), 68.7 (+, 1 C, 28), 87.4 (+, 1 C, 48), 121.5 (C_{quat}, 1 C, 52), 122.5 (C_{quat}, 1 C, 42), 123.4 (C_{quat}, 1 C, 32), 128.0 (+, 2 C, 30), 128.8 (+, 2 C, 40), 129.1 (+, 2 C, 50), 130.4 (+, 2 C, 51), 131.0 (+, 2 C, 41), 131.8 (+, 2 C, 31), 135.2 (C_{quat}, 1 C, 29), 136.4 (C_{quat}, 1 C, 39), 137.4 (C_{quat}, 1 C, 49), 156.8 (C_{quat}, 1 C, 4), 169.4 (C_{quat}, 1 C, 19), 170.9 (C_{quat}, 1 C, 13), 170.9 (C_{quat}, 1 C, 7), 171.5 (C_{quat}, 1 C, 22), 171.7 (C_{quat}, 1 C, 16), 171.9 (C_{quat}, 1 C, 10). – **MS** (ES, DCM/MeOH + 10 mM NH₄OAc): *m/z* (%) = 1231.3 (100) [MH⁺], 1248.5 (5) [MNH₄⁺]. – **IR** (neat) [cm⁻¹]: $\tilde{\nu}$ = 3253, 3313, 3240, 2962, 2945, 2887, 2361, 2340, 1733, 1658, 1595, 1523, 1454, 1259, 1116, 1007, 997, 826. – **MF** C₅₄H₆₉Br₃N₆O₁₂. – **MW** 1233.87.

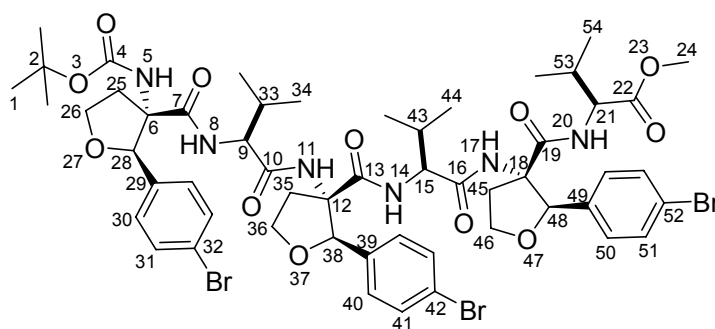

(S)-Methyl 2-((2R,3S)-2-(4-bromophenyl)-3-((S)-2-((2R,3S)-2-(4-bromophenyl)-3-((S)-2-((2R,3S)-2-(4-bromophenyl)-3-(tert-butoxycarbonylamino)-tetrahydrofuran-3-carboxamido)-3-methylbutanamido)-tetrahydrofuran-3-carboxamido)-3-methylbutanoate (172):

Under an atmosphere of nitrogen compound **183** (77 mg, 0.16 mmol, 1.5 eq.) was dissolved in 1.6 ml DMF (10 ml/mmol) and cooled to 0 °C in an ice bath. To the solution DIPEA (80 μ l, 0.47 mmol, 4.4 eq.), HOAt (33 mg, 0.23 mmol, 2.2 eq.) and HATU (89 mg, 0.23 mmol, 2.2 eq.) were added in this sequence. Then the amine **186** (85 mg, 0.11 mmol, 1.0 eq.) was slowly added in portions. The mixture was allowed to warm to room temperature and stirred for 24 hours. The reaction was quenched with 2 ml of water and 0.5 ml of 1M aqueous KHSO₄ and extracted with diethyl ether (3x5 ml). The combined organic layers were washed twice with brine. Afterwards the solution was dried over MgSO₄ and concentrated under reduced pressure. The crude product was then purified by column chromatography on flash silica gel (PE:diethyl ether 50:50, R_f = 0.29) to give the product as colorless solids with an overall yield of 21 % (28 mg, 0.023 mmol).

MP 241-242 °C. – **¹H-NMR** (600 MHz, COSY, CDCl₃): δ = 0.63 (d, ³J_{H,H} = 6.8, 6 H, 34 + 54), 0.68 (d, ³J_{H,H} = 7.0, 3 H, 44), 0.70 (d, ³J_{H,H} = 6.8, 3 H, 54), 0.79 (d, ³J_{H,H} = 6.2, 3 H, 34), 0.86 (d, ³J_{H,H} = 7.0, 3 H, 44), 1.52 (s, 9 H, 1), 1.68 (sextet, ³J_{H,H} = 6.5, 1 H, 53), 1.98-2.08 (m, 2 H, 33 + 35), 2.10-2.18 (m, 1 H, 43), 2.19-2.33 (m, 2 H, 25 + 45), 3.22 (dt, ²J_{H,H} = 13.2, ³J_{H,H} = 8.3, 1 H, 45), 3.27-3.39 (m, 4 H, 9 + 15 + 25 + 35), 3.49-3.53 (m, 1 H, 21), 3.61 (s, 3 H, 24), 3.83 (dd, ³J_{H,H} = 8.6, ²J_{H,H} = 16.1, 1 H, 36), 3.93 (dd, ³J_{H,H} = 8.3, ²J_{H,H} = 15.5, 1 H, 46), 4.17 (q, ³J_{H,H} = 7.6, 1 H, 26), 4.32 (dt, ³J_{H,H} = 3.7, ³J_{H,H} = 8.0, 1 H, 46), 4.37 (dt, ³J_{H,H} = 3.3, ³J_{H,H} = 8.4, 1 H, 36), 4.41 (dt, ³J_{H,H} = 5.0, ³J_{H,H} = 7.9, 1 H, 26), 4.89 (s, 1 H, 28), 5.09 (s, 1 H, 38), 5.16 (s, 1 H, 48), 7.22 (bs, 2 H, 30), 7.31 (d, ³J_{H,H} = 8.4, 2 H, 40), 7.32 (d, ³J_{H,H} = 8.6, 2 H, 51), 7.36 (d, ³J_{H,H} = 8.4, 2 H, 21), 7.41 (d, ³J_{H,H} = 8.6, 2 H, 50), 7.49 (d, ³J_{H,H} = 7.1, 2 H, 31). – **¹³C-NMR** (150 MHz, HSQC, HMBC, CDCl₃): δ = 16.3 (+, 1 C, 44), 17.1 (+, 1 C, 34), 18.4 (+, 1 C, 54), 18.5 (+, 2 C, 44 + 54), 18.9 (+, 1 C, 34), 28.4 (+, 3 C, 1), 29.0 (+, 1 C, 33), 29.1 (+, 1 C, 43), 29.8 (+, 1 C, 53), 36.4 (-, 1 C, 25), 37.4 (-,

1 C, 45), 37.8 (-, 1 C, 35), 51.7 (+, 1 C, 24), 59.3 (+, 1 C, 21), 60.3 (+, 1 C, 15), 61.2 (+, 1 C, 9), 67.9 (-, 1 C, 26), 68.0 (-, 1 C, 36), 68.3 (-, 1 C, 46), 70.6 (C_{quat}, 1 C, 6), 70.8 (C_{quat}, 1 C, 12), 71.2 (C_{quat}, 1 C, 18), 82.8 (C_{quat}, 1 C, 2), 86.5 (+, 2 C, 28 + 38), 87.1 (+, 1 C, 48), 121.9 (C_{quat}, 1 C, 52), 122.5 (C_{quat}, 1 C, 42), 123.2 (C_{quat}, 1 C, 32), 128.2 (+, 2 C, 30), 128.8 (+, 2 C, 40), 129.5 (+, 2 C, 50), 130.7 (+, 2 C, 51), 131.0 (+, 2 C, 41), 131.7 (+, 2 C, 31), 135.6 (C_{quat}, 1 C, 29), 136.3 (C_{quat}, 1 C, 39), 137.6 (C_{quat}, 1 C, 49), 157.0 (C_{quat}, 1 C, 4), 170.5 (C_{quat}, 2 C, CO), 170.6 (C_{quat}, 1 C, 19), 171.2 (C_{quat}, 1 C, CO), 171.9 (C_{quat}, 1 C, 22), 172.3 (C_{quat}, 1 C, CO). – **¹H-NMR** (600 MHz, COSY, ROESY, DMSO-*d*₆): δ = 0.56 (d, ³J_{H,H} = 6.7, 3 H, 54), 0.60 (d, ³J_{H,H} = 7.0, 3 H, 44), 0.62 (d, ³J_{H,H} = 6.9, 3 H, 54), 0.73 (d, ³J_{H,H} = 7.2, 3 H, 44), 0.74 (d, ³J_{H,H} = 7.6, 3 H, 34), 0.80 (d, ³J_{H,H} = 7.0, 3 H, 34), 1.48 (s, 9 H, 1), 1.49-1.56 (m, 1 H, 53), 1.86 (dq, ³J_{H,H} = 4.8, ³J_{H,H} = 6.8, 1 H, 43), 1.95 (dq, ³J_{H,H} = 3.8, ³J_{H,H} = 6.8, 1 H, 43), 2.03-2.16 (m, 3 H, 25 + 35 + 45), 2.86 (ddd, ³J_{H,H} = 8.4, ³J_{H,H} = 9.7, ²J_{H,H} = 13.3, 1 H, 45), 3.03-3.15 (m, 4 H, 9 + 15 + 25 + 35), 3.23 (t, ³J_{H,H} = 6.4, 1 H, 21), 3.47 (s, 3 H, 24), 3.63-3.73 (m, 2 H, 36 + 46), 3.99 (quartet, ³J_{H,H} = 8.1, 1 H, 36), 4.19 (dt, ³J_{H,H} = 2.8, ³J_{H,H} = 8.1, 1 H, 46), 4.26 (dd, ³J_{H,H} = 2.3, ³J_{H,H} = 8.2, 1 H, 36), 4.29 (dt, ³J_{H,H} = 3.5, ³J_{H,H} = 8.1, 1 H, 26), 4.95 (s, 1 H, 48), 4.96 (s, 1 H, 28), 5.07 (s, 1 H, 38), 7.11 (s, 1 H, 20), 7.11 (s, 1 H, 14), 7.22 (d, ³J_{H,H} = 8.5, 2 H, 30), 7.28 (d, ³J_{H,H} = 8.4, 2 H, 40 + 50), 7.40 (d, ³J_{H,H} = 8.5, 2 H, 51), 7.41 (s, 1 H, 17), 7.42 (d, ³J_{H,H} = 8.7, 2 H, 31), 7.46 (d, ³J_{H,H} = 8.4, 2 H, 41), 7.88 (d, ³J_{H,H} = 2.3, 1 H, 8), 8.22 (s, 1 H, 11), 8.31 (s, 1 H, 5), 7.55 (s, 1 H, 20), 7.99 (s, 1 H, 11). – **¹³C-NMR** (150 MHz, HSQC, HMBC, DMSO-*d*₆): δ = 16.8 (+, 1 C, 44), 18.1 (+, 1 C, 44), 18.1 (+, 1 C, 34), 18.52 (+, 1 C, 54), 18.5 (+, 1 C, 34), 18.7 (+, 1 C, 54), 28.1 (+, 3 C, 1), 28.5 (+, 1 C, 33), 28.8 (+, 1 C, 43), 29.4 (+, 1 C, 53), 35.7 (-, 1 C, 45), 36.0 (-, 1 C, 35), 37.0 (-, 1 C, 25), 51.1 (+, 1 C, 24), 58.7 (+, 1 C, 21), 60.5 (+, 1 C, 15), 61.2 (+, 1 C, 9), 67.3 (-, 2 C, 26 + 46), 67.4 (-, 1 C, 36), 70.4 (C_{quat}, 1 C, 18), 70.4 (C_{quat}, 1 C, 6), 70.5 (C_{quat}, 1 C, 12), 80.3 (C_{quat}, 1 C, 2), 84.4 (+, 1 C, 28), 85.5 (+, 1 C, 38), 86.2 (+, 1 C, 48), 121.0 (C_{quat}, 1 C, 52), 121.3 (C_{quat}, 1 C, 32), 123.5 (C_{quat}, 1 C, 42), 128.8 (+, 2 C, 30), 128.9 (+, 2 C, 40), 129.3 (+, 2 C, 50), 130.2 (+, 2 C, 51), 130.5 (+, 2 C, 31), 130.6 (+, 2 C, 41), 136.8 (C_{quat}, 1 C, 39), 137.2 (C_{quat}, 1 C, 29), 137.7 (C_{quat}, 1 C, 49), 156.7 (C_{quat}, 1 C, 4), 169.4 (C_{quat}, 1 C, 19), 170.3 (C_{quat}, 1 C, 13), 170.6 (C_{quat}, 1 C, 16), 170.7 (C_{quat}, 1 C, 22), 172.0 (C_{quat}, 1 C, 7), 172.2 (C_{quat}, 1 C, 10). – **MS** (ES, DCM/MeOH + 10 mM NH₄OAc): *m/z* (%) = 1231.5 (15) [MH⁺], 1248.5 (100) [MNH₄⁺]; 1234.6 (55) [M – H⁺], 1294.7 (100) [M + OAc⁻], 1366.6 (79) [M + TFA⁻ + H₂O]. – **IR** (neat) [cm⁻¹]: $\tilde{\nu}$ = 3252, 3313, 3238, 2965, 2941, 2887, 2358, 2340, 1735, 1669, 1595, 1519, 1461, 1259, 1114, 1007, 992, 826. – **MF** C₅₄H₆₉Br₃N₆O₁₂. – **MW** 1233.87.

X-Ray structure and crystal data of **172**:

Prism; space group: P 2₁; cell dimensions: $a = 14.51660(10) \text{ \AA}$, $\alpha = 90^\circ$, $b = 28.6529(2) \text{ \AA}$, $\beta = 104.3050(10)^\circ$, $c = 15.38410(10) \text{ \AA}$, $\gamma = 90^\circ$; $V = 6200.50(8) \text{ \AA}^3$; $Z = 4$, $D_x = 1.322 \text{ Mg/m}^3$; $\mu = 2.902 \text{ mm}^{-1}$; $F(000) = 2544$. Data collection: $T = 123 \text{ K}$; graphite monochromator. A translucent colorless crystal with dimensions of $0.270 \times 0.250 \times 0.240 \text{ mm}$ was used to measure 52330 reflections (21037 unique reflections, $R_{\text{int}} = 0.0293$) from 2.96° to 66.69° on a Oxford Diffraction Gemini Ultra diffractometer with the omega-scan method. Structure refinement: The F^2 value was refined using the full-matrix least squares refinement method, with a goodness-of-fit of 1.059 for all reflections and 1352 parameters.

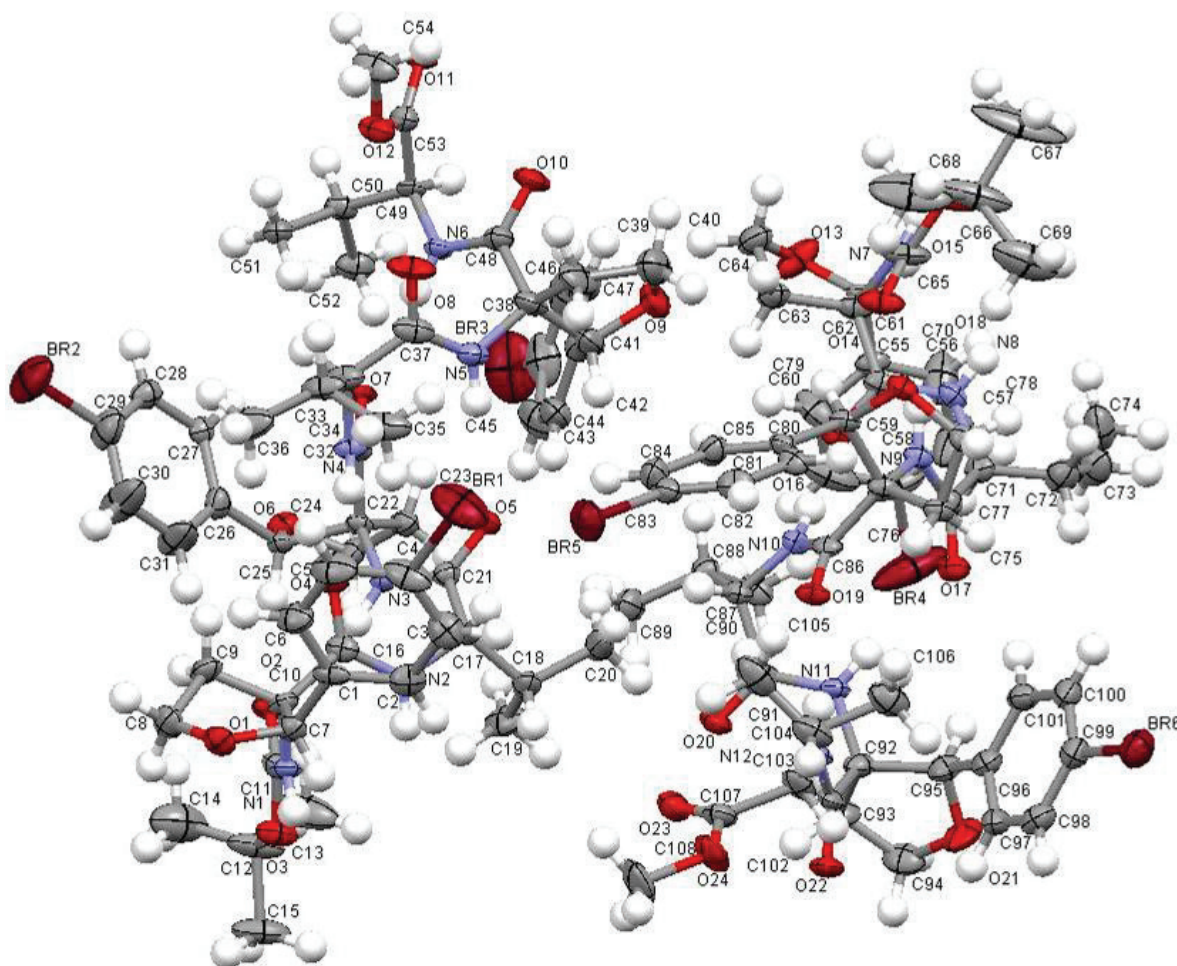

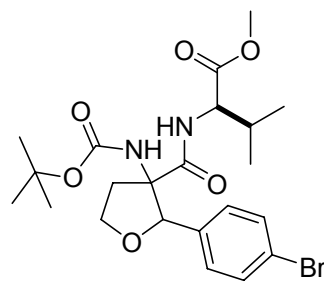

(2R)-Methyl 2-(2-(4-bromophenyl)-3-(tert-butoxycarbonylamino)-tetrahydrofuran-3-carboxamido)-3-methylbutanoate (173/176):

Under an atmosphere of nitrogen compound *rac*-**138** (1.40 g, 3.62 mmol, 1 eq.) was dissolved in 3.6 ml DMF (1 ml/mmol) and cooled to 0 °C in an ice bath. To the solution DIPEA (1.86 ml, 11.7 mmol, 3 eq.), HOBt (637 mg, 4.71 mmol, 1.3 eq.) and EDC (834 μ l, 4.71 mmol, 1.3 eq.) were added in this sequence. Then H-*D*-Val-OMe*HCl **187** (729 mg, 4.35 mmol, 1.2 eq.) was slowly added in portions. The mixture was allowed to warm to room temperature and stirred for 24 hours. The reaction was quenched with 5 ml of water and 3.5 ml of 1M aqueous KHSO₄ and extracted with diethyl ether (3x10 ml). The combined organic layers were washed twice with brine. Afterwards the solution was dried over MgSO₄ and concentrated under reduced pressure. The crude product was then purified by column chromatography on flash silica gel (PE:diethyl ether 80:20) to give the product as two diastereomers as colorless solids with an overall yield of 83 % (1.50 g, 3.00 mmol).

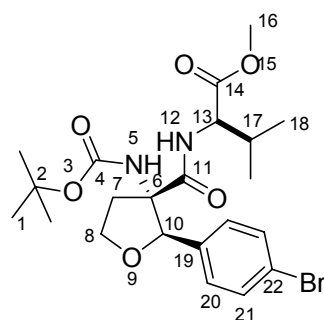

173: R_f (PE:diethyl ether 70:30) = 0.24

MP 146 °C. – **¹H-NMR** (300 MHz, CDCl₃): δ = 0.42 (d, ³J_{H,H} = 6.9, 3 H, 18), 0.56 (d, ³J_{H,H} = 6.9, 3 H, 18), 1.41 (s, 9 H, 1), 1.81 (dseptet, ³J_{H,H} = 4.5, ³J_{H,H} = 6.8, 1 H, 17), 2.42-2.63 (m, 1 H, 7), 2.65-2.89 (m, 1 H, 7), 3.64 (s, 3 H, 16), 4.16 (dd, ³J_{H,H} = 4.4, ³J_{H,H} = 8.5, 1 H, 13), 4.21-4.37 (m, 2 H, 8), 5.36 (bs, 1 H, 10), 6.11 (bs, 1 H, NH), 6.61 (d, ³J_{H,H} = 4.7, 1 H, NH), 7.20 (d, ³J_{H,H} = 8.6, 2 H, 20), 7.35 (d, ³J_{H,H} = 8.5, 2 H, 21). – **¹³C-NMR** (75 MHz, CDCl₃): δ = 17.3 (+, 1 C, 18), 18.3 (+, 1 C, 18), 28.4 (+, 3 C, 1), 31.0 (+, 1 C, 17), 36.1 (-, 1 C, 7), 52.2 (+, 1 C, 16), 57.3 (+, 1 C, 13), 66.6 (-, 1 C, 8), 67.6 (C_{quat}, 1 C, 6), 80.2 (C_{quat}, 1 C, 2), 80.5 (+, 1 C, 10), 121.6 (C_{quat}, 1 C, 22), 127.0 (+, 2 C, 20), 131.3 (+, 2 C, 21), 136.4 (C_{quat},

1 C, 19), 154.2 (C_{quat} , 1 C, 4), 171.1 (C_{quat} , 1 C, 11), 172.0 (C_{quat} , 1 C, 14). – **MS** (ES, DCM/MeOH + 10 mM NH_4OAc): m/z (%) = 498.8 (33) [$\text{MH}^+ - \text{Boc}$], 442.8 (65) [$\text{MH}^+ - \text{C}_4\text{H}_8$], 498.8 (100) [MH^+]; 422.9 (100) [$\text{M} - \text{H}^+ - \text{tBuOH}$], 497.1 (70) [$\text{M} - \text{H}^+$]. – **Elemental analysis** calcd. (%) for $\text{C}_{22}\text{H}_{31}\text{BrN}_2\text{O}_6$ (499.4): C 52.95, H 6.28, N 5.59; found: C 52.82, H 6.25, N 5.46. – **IR** (neat) [cm^{-1}]: $\tilde{\nu} = 3382, 3271, 2957, 2520, 2361, 1724, 1673, 1528, 1491, 1436, 1373, 1210, 1147, 1059, 1009, 830, 801$. – **MF** $\text{C}_{22}\text{H}_{31}\text{BrN}_2\text{O}_6$. – **MW** 499.4.

X-Ray structure and crystal data of **173**:

Monoclinic; space group: C 2; cell dimensions: $a = 19.0053(5) \text{ \AA}$, $\alpha = 90^\circ$, $b = 6.12864(16) \text{ \AA}$, $\beta = 106.886(3)^\circ$, $c = 20.6060(7) \text{ \AA}$, $\gamma = 90^\circ$; $V = 2296.64(12) \text{ \AA}^3$; $Z = 4$, $D_x = 1.444 \text{ Mg/m}^3$; $\mu = 2.781 \text{ mm}^{-1}$; $F(000) = 1040$. Data collection: $T = 123 \text{ K}$; graphite monochromator. A colorless crystal with dimensions of $0.470 \times 0.130 \times 0.050 \text{ mm}$ was used to measure 11706 reflections (3796 unique reflections, $R_{\text{int}} = 0.0521$) from 4.48° to 66.81° on a Oxford Diffraction Gemini Ultra diffractometer with the omega-scan method. Structure refinement: The F^2 value was refined using the full-matrix least squares refinement method, with a goodness-of-fit of 1.034 for all reflections and 286 parameters.

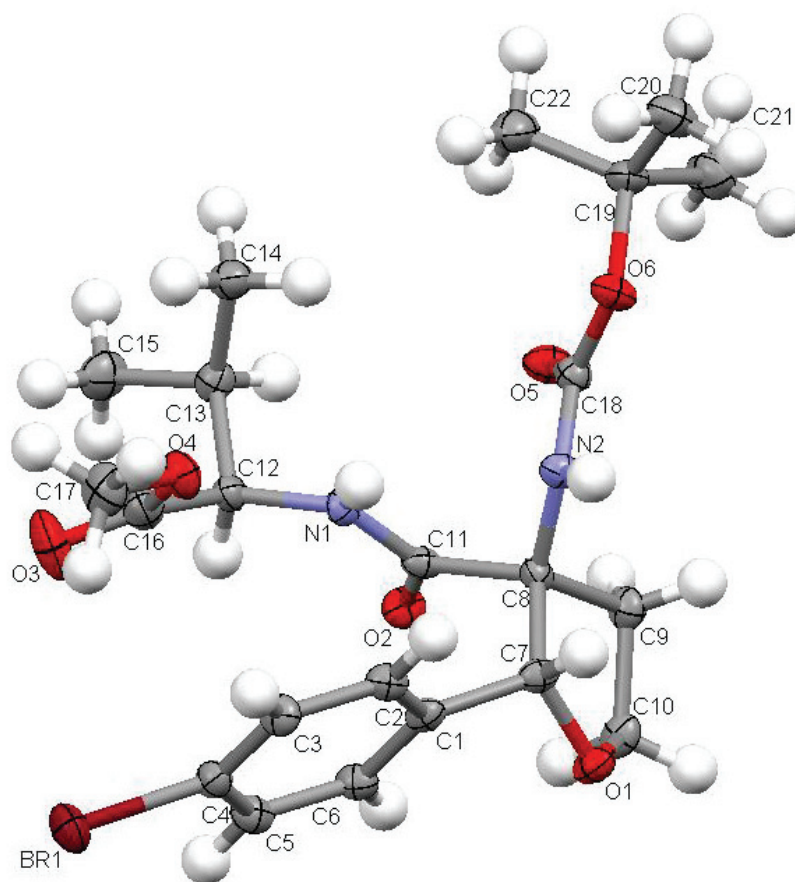

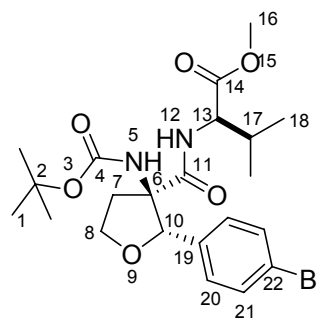

176: R_f (PE:diethyl ether = 70:30) = 0.20

MP 136 °C. – **$^1\text{H-NMR}$** (300 MHz, CDCl_3): δ = 0.60-0.79 (m, 6 H, 18), 1.41 (s, 9 H, 1), 1.76-2.06 (m, 1 H, 17), 2.35-2.57 (m, 1 H, 7), 2.64-2.90 (m, 1 H, 7), 3.56 (s, 3 H, 16), 4.03 (t, $^3J_{\text{H,H}}$ = 6.3, 1 H, 13), 4.25 (dd, $^3J_{\text{H,H}}$ = 4.8, $^3J_{\text{H,H}}$ = 8.1, 2 H, 8), 5.31 (bs, 1 H, 10), 6.14 (s, 1 H, NH), 6.61 (d, $^3J_{\text{H,H}}$ = 4.7, 1 H, NH), 7.13 (d, $^3J_{\text{H,H}}$ = 8.2, 2 H, 20), 7.31 (d, $^3J_{\text{H,H}}$ = 8.5, 2 H, 21). – **$^{13}\text{C-NMR}$** (75 MHz, CDCl_3): δ = 17.9 (+, 1 C, 18), 18.7 (+, 1 C, 18), 28.4 (+, 3 C, 1), 31.7 (+, 1 C, 17), 36.1 (-, 1 C, 7), 52.1 (+, 1 C, 16), 57.3 (+, 1 C, 13), 66.5 (-, 1 C, 8), 67.7 (C_{quat} , 1 C, 6), 80.2 (C_{quat} , 1 C, 2), 80.9 (+, 1 C, 10), 121.6 (C_{quat} , 1 C, 22), 127.3 (+, 2 C, 20), 131.0 (+, 2 C, 21), 135.6 (C_{quat} , 1 C, 19), 154.3 (C_{quat} , 1 C, 4), 171.3 (C_{quat} , 2 C, 11 + 14). – **MS** (CI, NH_3): m/z (%) = 442.8 (37) [$\text{MH}^+ - \text{C}_4\text{H}_8$], 498.9 (100) [MH^+], 516.0 (20) [MNH_4^+]; 422.7 (55) [$\text{M} - \text{H}^+ - \text{C}_4\text{H}_{10}\text{O}$], 497.0 (100) [$\text{M} - \text{H}^+$]. – **Elemental analysis** calcd. (%) for $\text{C}_{22}\text{H}_{31}\text{BrN}_2\text{O}_6$ (499.4): C 52.91, H 6.26, N 5.61; found: C 52.86, H 6.21, N 5.41. – **IR** (neat) [cm^{-1}]: $\tilde{\nu}$ = 3441, 3270, 2956, 2877, 2357, 1742, 1720, 1654, 1507, 1367, 1245, 1162, 1088, 1016, 988, 798. – **MF** $\text{C}_{22}\text{H}_{31}\text{BrN}_2\text{O}_6$. – **MW** 499.4.

X-Ray structure and crystal data of **176**:

Orthorhombic; space group: P 21 21 21; cell dimensions: $a = 6.18536(6)$ Å, $\alpha = 90^\circ$, $b = 17.91432(12)$ Å, $\beta = 90^\circ$, $c = 21.08060(15)$ Å, $\gamma = 90^\circ$; $V = 2335.87(3)$ Å³; $Z = 4$, $D_x = 1.420$ Mg/m³; $\mu = 2.734$ mm⁻¹; $F(000) = 1040$. Data collection: $T = 123$ K; graphite monochromator. A colorless crystal with dimensions of 0.500 x 0.120 x 0.040 mm was used to measure 19627 reflections (4015 unique reflections, $R_{\text{int}} = 0.0361$) from 3.24° to 66.69° on a Oxford Diffraction Gemini Ultra diffractometer with the omega-scan method. Structure refinement: The F^2 value was refined using the full-matrix least squares refinement method, with a goodness-of-fit of 1.051 for all reflections and 286 parameters.

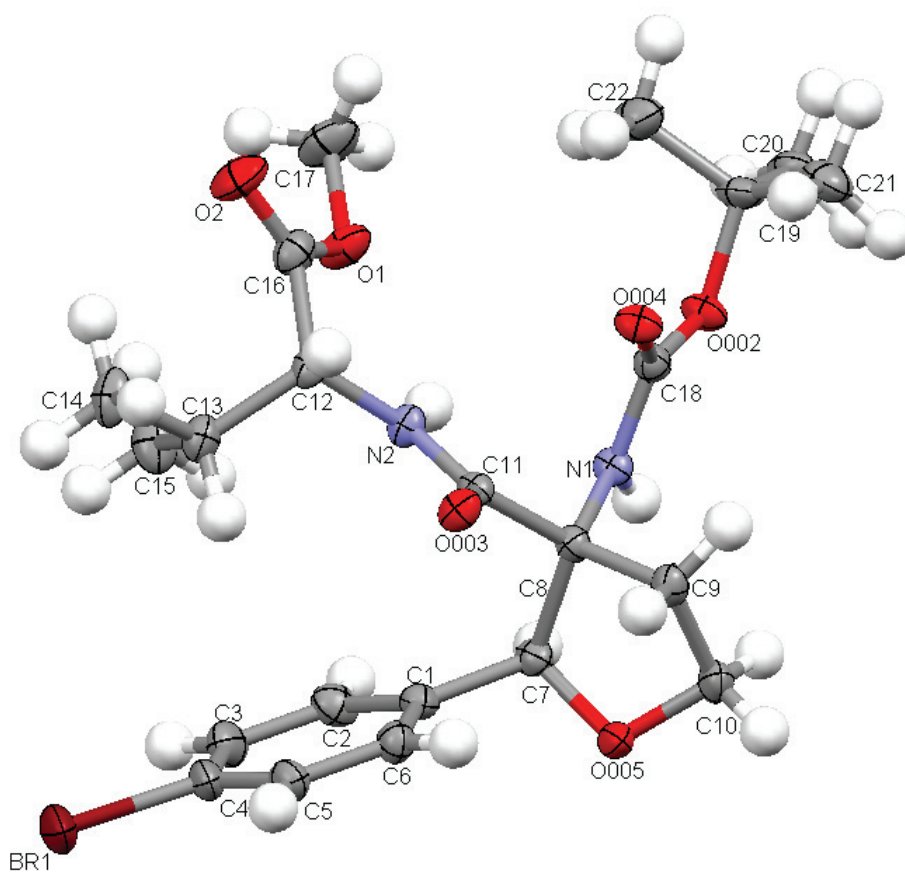

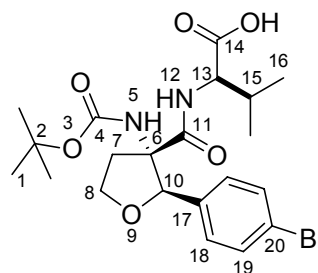

(R)-2-((2R,3S)-2-(4-Bromophenyl)-3-(tert-butoxycarbonylamino)-tetrahydrofuran-3-carbox-amido)-3-methylbutanoic acid (**188**):

Compound **173** (480 mg, 0.96 mmol) was dissolved in 24 ml of a MeCN:water mixture (4:1, 25 ml/mmol). To the solution 1M aqueous LiOH (1.06 ml, 1.06 mmol) was added drop by drop. The mixture was stirred over night at room temperature. After acidification with 1M aqueous KHSO₄ solution the mixture was extracted with DCM (3x10 ml). The combined organic layers were dried over MgSO₄ and concentrated under reduced pressure to give the product as colorless solid 94 % yield. (440 mg, 0.91 mmol)

MP 132-133 °C. – **¹H-NMR** (300 MHz, CDCl₃): δ = 0.48 (d, ³J_{H,H} = 5.2, 3 H, 16), 0.67 (d, ³J_{H,H} = 6.0, 3 H, 16), 1.47 (m, 9 H, 1), 1.95 (dq, ³J_{H,H} = 4.4, ³J_{H,H} = 6.7, 1 H, 15), 2.49-2.67 (m, 1 H, 7), 2.73-2.88 (m, 1 H, 7), 4.22-4.36 (m, 3 H, 8 + 13), 5.45 (bs, 1 H, 10), 6.21 (bs, 1 H, NH), 6.50 (d, ³J_{H,H} = 7.9, 1 H, NH), 7.25 (d, ³J_{H,H} = 8.2, 2 H, 18), 7.40 (d, ³J_{H,H} = 8.5, 2 H, 19). – **¹³C-NMR** (75 MHz, CDCl₃): δ = 17.2 (+, 1 C, 16), 18.4 (+, 1 C, 16), 28.4 (+, 3 C, 1), 30.7 (-, 1 C, 15), 36.0 (-, 1 C, 7), 57.1 (+, 1 C, 13), 66.5 (-, 1 C, 8), 67.5 (C_{quat}, 1 C, 6), 80.1 (+, 1 C, 10), 80.3 (C_{quat}, 1 C, 2), 121.6 (C_{quat}, 1 C, 20), 127.0 (+, 2 C, 18), 131.4 (+, 2 C, 19), 136.4 (C_{quat}, 1 C, 17), 154.3 (C_{quat}, 1 C, 4), 171.4 (C_{quat}, 1 C, 11), 176.4 (C_{quat}, 1 C, 14). – **MS** (ES, DCM/MeOH + 10 mmol/l NH₄OAc): *m/z* (%) = 484.9 (100) [MH⁺], 502.0 (38) [MNH₄⁺]; 483.0 (100) [M – H⁺], 543 (18) [M + OAc⁻], 969.9 (56) [2M – H⁺]. – **IR** (neat) [cm⁻¹]: $\tilde{\nu}$ = 3394, 2960, 2362, 2341, 1723, 1672, 1509, 1437, 1213, 1145, 1070, 1010, 830, 703. – **MF** C₂₁H₂₉BrN₂O₆. – **MW** 485.37.

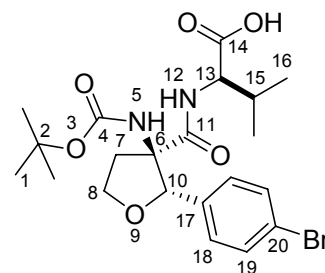

(R)-2-((2S,3R)-2-(4-Bromophenyl)-3-(tert-butoxycarbonylamino)-tetrahydrofuran-3-carboxamido)-3-methylbutanoic acid (**190**):

Compound **176** (490 mg, 0.98 mmol) was dissolved in 25 ml of a MeCN:water mixture (4:1, 25 ml/mmol). To the solution 1M aqueous LiOH (1.08 ml, 1.08 mmol) was added drop by drop. The mixture was stirred over night at room temperature. After acidification with 1M aqueous KHSO₄ solution the mixture was extracted with DCM (3x10 ml). The combined organic layers were dried over MgSO₄ and concentrated under reduced pressure to give the product as colorless solid 93 % yield. (440 mg, 0.91 mmol)

MP 118-120 °C. – **¹H-NMR** (300 MHz, CDCl₃): δ = 0.44 (d, ³J_{H,H} = 5.2, 3 H, 16), 0.62 (d, ³J_{H,H} = 5.8, 3 H, 18), 1.42 (m, 9 H), 1.78-1.95 (m, 1 H, 15), 2.41-2.65 (m, 1 H, 7), 2.67-2.86 (m, 1 H, 7), 4.13-4.39 (m, 3 H, 8 + 13), 5.39 (bs, 1 H, 10), 6.17 (bs, 1 H, NH), 6.47 (d, ³J_{H,H} = 7.7, 1 H, NH), 7.20 (d, ³J_{H,H} = 8.2, 2 H, 18), 7.35 (d, ³J_{H,H} = 8.8, 2 H, 19). – **¹³C-NMR** (75 MHz, CDCl₃): δ = 17.8 (+, 1 C, 16), 18.8 (+, 1 C, 16), 28.4 (+, 3 C, 1), 31.4 (-, 1 C, 15), 36.2 (-, 1 C, 7), 57.2 (+, 1 C, 13), 66.5 (-, 1 C, 8), 67.8 (C_{quat}, 1 C, 6), 80.5 (+, 1 C, 10), 81.2 (C_{quat}, 1 C, 2), 121.8 (C_{quat}, 1 C, 20), 127.4 (+, 2 C, 18), 131.2 (+, 2 C, 19), 135.4 (C_{quat}, 1 C, 17), 154.5 (C_{quat}, 1 C, 4), 171.4 (C_{quat}, 1 C, 11), 175.7 (C_{quat}, 1 C, 14). – **MS** (ES, DCM/MeOH + 10 mmol/l NH₄OAc): *m/z* (%) = 483.1 (100) [M - H⁺]; 967.4 (51) [2M - H⁺]. – **IR** (neat) [cm⁻¹]: $\tilde{\nu}$ = 3394, 2960, 2362, 2341, 1723, 1672, 1509, 1437, 1213, 1145, 1070, 1010, 830, 703. – **MF** C₂₁H₂₉BrN₂O₆. – **MW** 485.37.

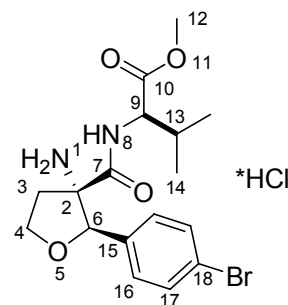

(R)-Methyl 2-((2R,3S)-3-amino-2-(4-bromophenyl)-tetrahydrofuran-3-carboxamido)-3-methyl-butanoate (189):

Compound **173** (400 mg, 0.80 mmol) was dissolved under ice bath cooling at 0 °C in ether. To this solution 5.6 ml ice cold HCl saturated ether (7 ml/mmol Boc) was added and the mixture was stirred over night at room temperature. The solvent was removed under reduced pressure to give the HCl salt of the product as white hygroscopic solid in quantitative yield (345 mg, 0.80 mmol). No further purification was necessary.

MP >180 °C. – **¹H-NMR** (300 MHz, MeOH-*d*₄): δ = 0.62 (d, ³J_{H,H} = 6.9, 3 H, 14), 0.65 (d, ³J_{H,H} = 6.9, 3 H, 14), 1.78 (sextet, ³J_{H,H} = 6.7, 1 H, 13), 2.39 (ddd, ³J_{H,H} = 2.5, ³J_{H,H} = 7.1, ²J_{H,H} = 14.3, 1 H, 3), 3.00 (dt, ²J_{H,H} = 14.4, ³J_{H,H} = 9.2, 1 H, 1 H, 3), 3.67 (s, 3 H, 12), 3.84 (d, ³J_{H,H} = 6.3, 1 H, 9), 4.21 (dt, ³J_{H,H} = 7.1, ³J_{H,H} = 9.3, 1 H, 4), 4.53 (dt, ³J_{H,H} = 2.5, ³J_{H,H} = 9.1, 1 H, 4), 5.00 (s, 1 H, 6), 7.33 (d, ³J_{H,H} = 8.2, 2 H, 16), 7.52 (d, ³J_{H,H} = 8.5, 2 H, 17). – **¹³C-NMR** (75 MHz, MeOH-*d*₄): δ = 21.6 (+, 1 C, 14), 21.9 (+, 1 C, 14), 33.6 (+, 1 C, 13), 38.5 (-, 1 C, 3), 55.1 (+, 1 C, 12), 63.1 (+, 1 C, 9), 70.3 (-, 1 C, 4), 72.4 (C_{quat}, 1 C, 2), 89.3 (+, 1 C, 10), 126.3 (C_{quat}, 1 C, 18), 131.7 (+, 2 C, 16), 135.3 (+, 2 C, 17), 138.7 (C_{quat}, 1 C, 15), 171.7 (C_{quat}, 1 C, 7), 175.7 (C_{quat}, 1 C, 10). – **MS** (ES, DCM/MeOH + 10 mmol/l NH₄OAc): *m/z* (%) = 398.9 (100) [MH⁺], 799.2 (34) [2m + H⁺]; 397 (100) [M – H⁺], 456.9 (24) [M + OAc⁻]. – **IR** (neat) [cm⁻¹]: $\tilde{\nu}$ = 3399, 2957, 2526, 2362, 2341, 1723, 1672, 1509, 1488, 1437, 1212, 1069, 1009, 829, 803. – **MF** C₁₇H₂₃BrN₂O₄*HCl. – **MW** 435.74.

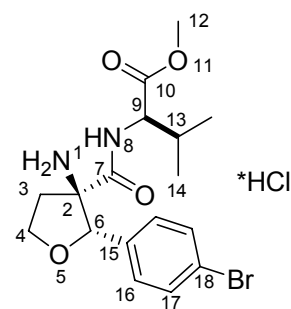

(R)-Methyl 2-((2S,3R)-3-amino-2-(4-bromophenyl)-tetrahydrofuran-3-carboxamido)-3-methyl-butanoate (191):

Compound **176** (350 mg, 0.70 mmol) was dissolved under ice bath cooling at 0 °C in ether. To this solution 4.9 ml ice cold HCl saturated ether (7 ml/mmol Boc) was added and the mixture was stirred over night at room temperature. The solvent was removed under reduced pressure to give the HCl salt of the product as white hygroscopic solid in quantitative yield (304 mg, 0.76 mmol). No further purification was necessary.

MP > 180 °C. – **¹H-NMR** (300 MHz, MeOH-*d*₄): δ = 0.85 (t, ³J_{H,H} = 6.6, 6 H, 14), 2.02 (sextet, ³J_{H,H} = 7.0, 1 H, 13), 2.41 (ddd, ³J_{H,H} = 2.6, ³J_{H,H} = 7.5, ²J_{H,H} = 14.4, 1 H, 3), 2.92 (dt, ²J_{H,H} = 14.4, ³J_{H,H} = 9.1, 1 H, 3), 3.67 (s, 3 H, 12), 4.04 (d, ³J_{H,H} = 7.1, 1 H, 9), 4.19 (dt, ³J_{H,H} = 7.6, ³J_{H,H} = 9.2, 1 H, 4), 4.53 (dt, ³J_{H,H} = 2.7, ³J_{H,H} = 9.0, 1 H, 4), 4.99 (s, 1 H, 6), 7.28 (d, ³J_{H,H} = 8.5, 2 H, 16), 7.46 (d, ³J_{H,H} = 8.5, 2 H, 17). – **¹³C-NMR** (75 MHz, MeOH-*d*₄): δ = 18.9 (+, 1 C, 14), 19.3 (+, 1 C, 14), 32.6 (+, 1 C, 13), 36.1 (-, 1 C, 3), 52.7 (+, 1 C, 12), 59.5 (+, 1 C, 9), 67.8 (-, 1 C, 4), 69.8 (C_{quat}, 1 C, 2), 87.0 (+, 1 C, 10), 123.7 (C_{quat}, 1 C, 18), 129.4 (+, 2 C, 16), 132.5 (+, 2 C, 17), 135.3 (C_{quat}, 1 C, 15), 168.8 (C_{quat}, 1 C, 7), 172.3 (C_{quat}, 1 C, 10). – **MS** (ES, DCM/MeOH + 10 mmol/l NH₄OAc): *m/z* (%) = 398.9 (100) [MH⁺]; 387.0 (100) [M – H⁺], 433.0 (17) [M + Cl], 457 (15) [M + OAc]. – **IR** (neat) [cm⁻¹]: $\tilde{\nu}$ = 3288, 2965, 2874, 2362, 2341, 1749, 1684, 1646, 1519, 1488, 1157, 1074, 1010, 841. – **MF** C₁₇H₂₃BrN₂O₄*HCl. – **MW** 435.74.

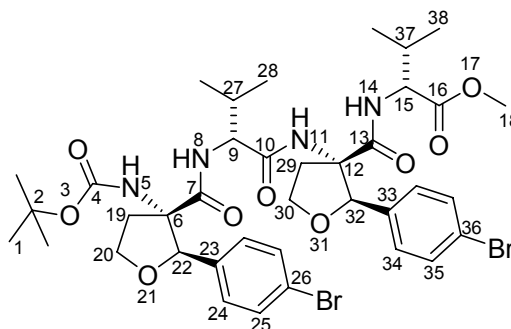

(R)-Methyl 2-((2*r*,3*S*)-2-(4-bromophenyl)-3-((R)-2-((2*R*,3*S*)-2-(4-bromophenyl)-3-(tert-butoxycarbonylamino)-tetrahydrofuran-3-carboxamido)-3-methylbutanamido)-tetrahydrofuran-3-carbox-amido)-3-methylbutanoate (**174**):

Under an atmosphere of nitrogen compound **188** (220 mg, 0.45 mmol, 1 eq.) was dissolved in 3.6 ml DMF (8 ml/mmol) and cooled to 0 °C in an ice bath. To the solution DIPEA (233 μ l, 1.36 mmol, 3 eq.), HOAt (93 mg, 0.68 mmol, 1.5 eq.) and HATU (259 mg, 0.68 mmol, 1.5 eq.) were added in this sequence. Then the amine **189** (178 mg, 0.41 mmol, 0.9 eq.) was slowly added in portions. The mixture was allowed to warm to room temperature and stirred for 24 hours. The reaction was quenched with 3 ml of water and 1.5 ml of 1M aqueous KHSO₄ and extracted with diethyl ether (3x10 ml). The combined organic layers were washed twice with brine. Afterwards the solution was dried over MgSO₄ and concentrated under reduced pressure. The crude product was then purified by column chromatography on flash silica gel (PE:diethyl ether 60:40, R_f = 0.14) to give the product as colorless solids with an overall yield of 55 % (196 mg, 0.23 mmol).

MP 163-164 °C. – **¹H-NMR** (600 MHz, COSY, CDCl₃): δ = 0.65 (d, ³J_{H,H} = 6.0, 6 H, 28 + 38), 0.74 (d, ³J_{H,H} = 6.6, 3 H, 38), 0.80 (d, ³J_{H,H} = 6.8, 3 H, 28), 1.47 (s, 9 H, 1), 1.91-1.99 (m, 1 H, 37), 2.00 (sextet, ³J_{H,H} = 6.2, 1 H, 27), 2.43-2.60 (m, 2 H, 19 + 29), 2.82-2.91 (m, 1 H, 29), 3.16 (bs, 1 H, 19), 3.57-70 (m, 4 H, 9 + 18), 3.96-4.05 (m, 1 H, 30), 4.16 (dd, ³J_{H,H} = 5.6, ³J_{H,H} = 8.9, 1 H, 15), 4.22 (quartet, ³J_{H,H} = 7.6, 1 H, 20), 4.33 (dt, ³J_{H,H} = 2.9, ³J_{H,H} = 8.5, 1 H, 30), 4.43 (dt, ³J_{H,H} = 5.2, ³J_{H,H} = 8.5, 1 H, 20), 5.00 (s, 1 H, 22), 5.21 (s, 1 H, 32), 5.87 (s, 1H 5), 6.29 (s, 1H, 8), 6.88 (d, ³J_{H,H} = 7.3, 1 H, 14), 7.14 (d, ³J_{H,H} = 8.4, 2 H, 24), 7.17 (d, ³J_{H,H} = 8.4, 2 H, 34), 7.29 (d, ³J_{H,H} = 7.7, 2 H, 25), 7.35 (d, ³J_{H,H} = 8.4, 2 H, 35), 7.49 (s, 1 H, 11). – **¹³C-NMR** (150 MHz, CDCl₃): δ = 17.3 (+, 1 C, 28), 17.7 (+, 1 C, 38), 18.7 (+, 1 C, 38), 19.0 (+, 1 C, 28), 28.4 (+, 3 C, 1), 29.9 (+, 1 C, 27), 31.2 (+, 1 C, 37), 35.4 (-, 1 C, 29), 35.9 (-, 1 C, 19), 51.8 (+, 1 C, 18), 57.5 (+, 1 C, 15), 59.7 (+, 1 C, 9), 67.4 (-, 1 C, 30), 67.6 (-, 1 C, 20), 69.1 (C_{quat}, 1 C, 6), 69.7 (C_{quat}, 1 C, 12), 81.8 (C_{quat}, 1 C, 2), 83.9 (+, 1 C, 32), 84.4 (+, 1 C, 22), 121.7 (C_{quat}, 1 C, 36), 122.6 (C_{quat}, 1 C, 26), 127.7 (+, 2 C, 24), 129.0 (+, 2 C, 34), 131.0 (+, 2 C, 35), 131.4 (+, 2 C, 25), 135.1 (C_{quat}, 1 C, 23), 136.6 (C_{quat}, 1 C, 33), 155.5 (C_{quat}, 1 C, 4), 169.7 (C_{quat}, 1 C, 13), 169.9 (C_{quat}, 1 C,

10), 171.1 (C_{quat} , 1 C, 7), 171.9 (C_{quat} , 1 C, 16). – **MS** (ES, DCM/MeOH + 10 mM NH_4OAc): m/z (%) = 867.2 (100) [MH^+], 884.3 (74) [MNH_4^+]; 865.3 (100) [$\text{M} - \text{H}^+$], 925.3 (25) [$\text{M} + \text{OAc}^-$]. – **HR-MS** (PI-LSIMS, DCM/NBA): [MH^+] calcd. for $\text{C}_{38}\text{H}_{51}\text{Br}_2\text{N}_4\text{O}_9$ 865.2036; found 865.2022. – **IR** (neat) [cm^{-1}]: $\tilde{\nu}$ = 3254, 3313, 3240, 2964, 2941, 2886, 2359, 2341, 1735, 1668, 1597, 1519, 1462, 1259, 1118, 1008, 995, 828. – **MF** $\text{C}_{38}\text{H}_{50}\text{Br}_2\text{N}_4\text{O}_9$. – **MW** 866.63.

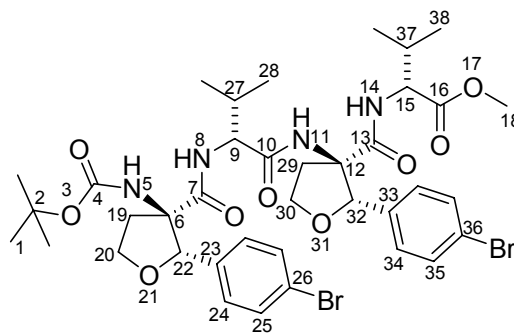

(R)-Methyl 2-((2S,3R)-2-(4-bromophenyl)-3-((R)-2-((2S,3R)-2-(4-bromophenyl)-3-(tert-butoxycarbonylamino)-tetrahydrofuran-3-carboxamido)-3-methylbutanamido)-tetrahydrofuran-3-carbox-amido)-3-methylbutanoate (**177**):

Under an atmosphere of nitrogen compound **190** (230 mg, 0.47 mmol, 1 eq.) was dissolved in 3.8 ml DMF (8 ml/mmol) and cooled to 0 °C in an ice bath. To the solution DIPEA (243 μl , 1.42 mmol, 3 eq.), HOAt (97 mg, 0.71 mmol, 1.5 eq.) and HATU (270 mg, 0.71 mmol, 1.5 eq.) were added in this sequence. Then the amine **191** (186 mg, 0.43 mmol, 0.9 eq.) was slowly added in portions. The mixture was allowed to warm to room temperature and stirred for 24 hours. The reaction was quenched with 3 ml of water and 1.5 ml of 1M aqueous KHSO_4 and extracted with diethyl ether (3x10 ml). The combined organic layers were washed twice with brine. Afterwards the solution was dried over MgSO_4 and concentrated under reduced pressure. The crude product was then purified by column chromatography on flash silica gel (PE:diethyl ether 50:50, R_f = 0.13) to give the product as colorless solids with an overall yield of 58 % (217 mg, 0.25 mmol).

MP 147-148 °C. – **$^1\text{H-NMR}$** (600 MHz, $\text{MeOH-}d_4$): δ = 0.64 (d, $^3J_{\text{H,H}}$ = 7.0, 3 H, 28), 0.66 (d, $^3J_{\text{H,H}}$ = 7.0, 3 H, 38), 0.73 (d, $^3J_{\text{H,H}}$ = 6.8, 3 H, 38), 0.81 (d, $^3J_{\text{H,H}}$ = 7.0, 3 H, 28), 1.51 (s, 9 H, 1), 1.64 (sextet, $^3J_{\text{H,H}}$ = 6.8, 1 H, 37), 1.91-1.98 (m, 1 H, 27), 2.16-2.23 (m, 2 H, 19 + 29), 3.10 (ddd, $^3J_{\text{H,H}}$ = 8.5, $^3J_{\text{H,H}}$ = 10.3, $^2J_{\text{H,H}}$ = 13.4, 29), 3.24-3.34 (m, 2 H, 9 + 19), 3.41 (t, $^3J_{\text{H,H}}$ = 6.7, 1 H, 15), 3.59 (s, 3 H, 18), 3.69-3.78 (m, 1 H, 30), 4.09 (q, $^3J_{\text{H,H}}$ = 8.1, 1 H, 20), 4.26 (dt, $^3J_{\text{H,H}}$ = 2.4, $^3J_{\text{H,H}}$ = 8.4, 1 H, 30), 4.34 (dt, $^3J_{\text{H,H}}$ = 4.6, $^3J_{\text{H,H}}$ = 8.4, 1 H, 20), 4.89 (s, 1 H, 22), 5.14 (s, 1 H, 32), 6.66 (d, $^3J_{\text{H,H}}$ = 3.7, 1 H, NH), 7.26 (d, $^3J_{\text{H,H}}$ = 8.4, 2 H, 24), 7.37 (d, $^3J_{\text{H,H}}$ = 8.6, 2 H, 34), 7.39 (d, $^3J_{\text{H,H}}$ = 8.8, 2 H, 35), 7.47 (d, $^3J_{\text{H,H}}$ = 8.4, 2 H,

25). – **¹³C-NMR** (150 MHz, MeOH-*d*₄): δ = 17.9 (+, 1 C, 28), 19.0 (+, 1 C, 38), 19.2 (+, 1 C, 28), 19.7 (+, 1 C, 38), 28.7 (+, 3 C, 1), 30.5 (+, 1 C, 27), 31.2 (+, 1 C, 37), 37.8 (-, 1 C, 29), 38.0 (-, 1 C, 19), 52.0 (+, 1 C, 18), 61.0 (+, 1 C, 15), 61.9 (+, 1 C, 9), 68.8 (-, 2 C, 20 + 30), 72.0 (C_{quat}, 1 C, 6), 72.5 (C_{quat}, 1 C, 12), 82.6 (C_{quat}, 1 C, 2), 86.9 (+, 1 C, 22), 88.3 (+, 1 C, 32), 123.2 (C_{quat}, 1 C, 36), 123.7 (C_{quat}, 1 C, 26), 129.8 (+, 2 C, 24), 130.5 (+, 2 C, 34), 131.9 (+, 2 C, 35), 132.4 (+, 2 C, 25), 137.9 (C_{quat}, 1 C, 23), 138.4 (C_{quat}, 1 C, 33), 158.8 (C_{quat}, 1 C, 4), 172.1 (C_{quat}, 1 C, 13), 172.7 (C_{quat}, 1 C, 10), 172.8 (C_{quat}, 1 C, 16), 173.3 (C_{quat}, 1 C, 7). – **MS** (ES, DCM/MeOH + 10 mM NH₄OAc): *m/z* (%) = 867.2 (100) [MH⁺], 884.2 (21) [MNH₄⁺]; 865.3 (100) [M – H⁺]. – **HR-MS** (PI-LSIMS, DCM/NBA): [MH⁺] calcd. for C₃₈H₅₁Br₂N₄O₉ 865.2036; found 865.2039. – **IR** (neat) [cm⁻¹]: $\tilde{\nu}$ = 3252, 3313, 3240, 2965, 2941, 2887, 2359, 2340, 1735, 1668, 1595, 1519, 1460, 1259, 1114, 1007, 995, 826. – **MF** C₃₈H₅₀Br₂N₄O₉. – **MW** 866.63.

X-Ray structure and crystal data of **177**:

Prism; space group: P 21 21 21; cell dimensions: $a = 10.19490(10)$ Å, $\alpha = 90^\circ$, $b = 16.36340(10)$ Å, $\beta = 90^\circ$, $c = 50.9856(4)$ Å, $\gamma = 90^\circ$; $V = 8505.58(12)$ Å³; $Z = 4$, $D_x = 1.389$ Mg/m³; $\mu = 2.889$ mm⁻¹; $F(000) = 3684$. Data collection: $T = 123$ K; graphite monochromator. A colorless crystal with dimensions of 0.230 x 0.110 x 0.080 mm was used to measure 58646 reflections (14747 unique reflections, $R_{\text{int}} = 0.0299$) from 2.84° to 66.63° on a Oxford Diffraction Gemini Ultra diffractometer with the omega-scan method. Structure refinement: The F^2 value was refined using the full-matrix least squares refinement method, with a goodness-of-fit of 1.034 for all reflections and 1006 parameters.

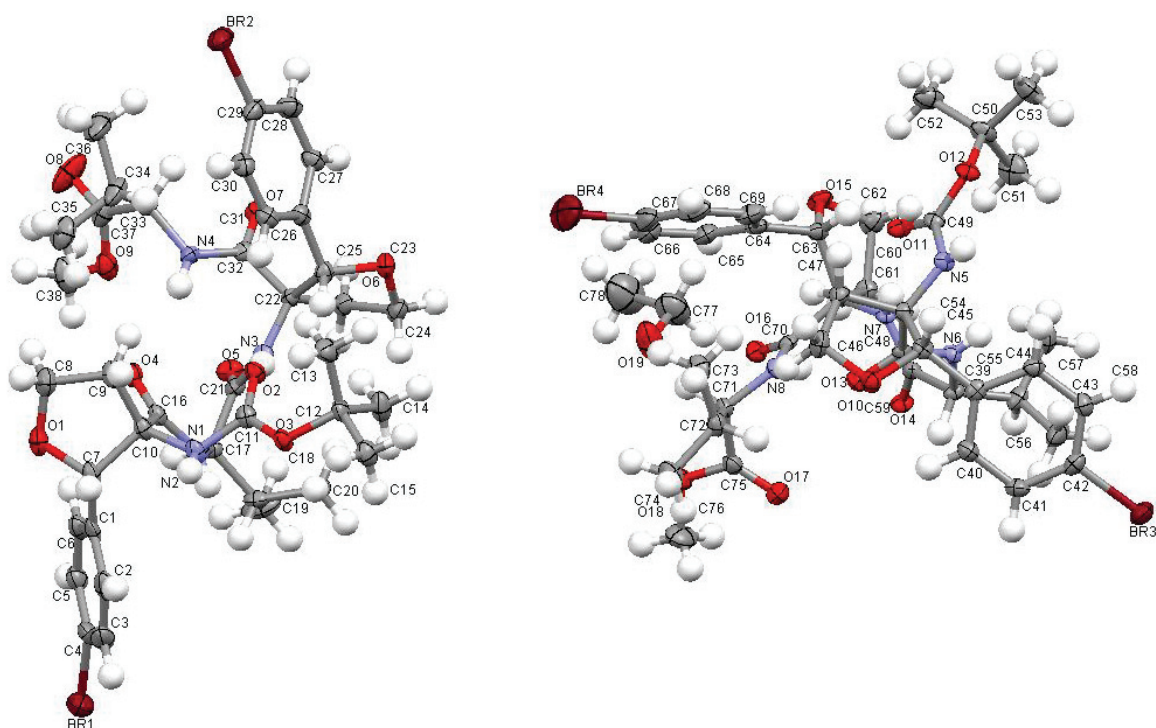

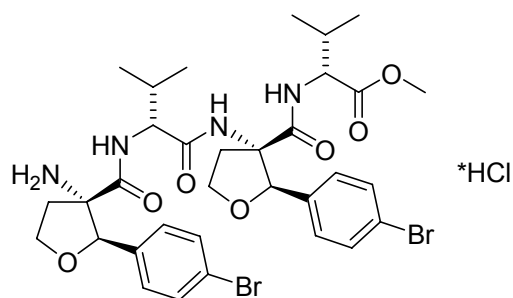

(R)-Methyl 2-((2R,3S)-3-((R)-2-((2R,3S)-3-amino-2-(4-bromophenyl)-tetrahydrofuran-3-carboxamido)-3-methylbutanamido)-2-(4-bromophenyl)-tetrahydrofuran-3-carboxamido)-3-methylbutanoate · HCl (192):

Compound **174** (190 mg, 0.22 mmol) was dissolved under ice bath cooling at 0 °C in dichloromethane. To this solution 1.5 ml ice cold HCl saturated ether (7 ml/mmol Boc) was added and the mixture was stirred over night at room temperature. The solvent was removed under reduced pressure to give the HCl salt of the product as white hygroscopic solid in quantitative yield (176 mg, 0.22 mmol). No further purification was necessary.

MP > 180 °C. – **¹H-NMR** (300 MHz, MeOH-*d*₄): δ = 0.66 (d, ³J_{H,H} = 6.9, 3 H, Val-CH₃), 0.71 (d, ³J_{H,H} = 6.9, 3 H, Val-CH₃), 0.94 (d, ³J_{H,H} = 6.9, 3 H, Val-CH₃), 0.97 (d, ³J_{H,H} = 6.9, 3 H, Val-CH₃), 1.81 (sextet, ³J_{H,H} = 6.6, 1 H, Val-CH), 2.09 (sextet, ³J_{H,H} = 6.5, 1 H, Val-CH), 2.22 (ddd, ³J_{H,H} = 3.4, ³J_{H,H} = 7.6, ²J_{H,H} = 12.8, 1 H, CH₂), 2.48 (ddd, ³J_{H,H} = 3.5, ³J_{H,H} = 8.2, ²J_{H,H} = 14.0, 1 H, CH₂), 2.86-3.03 (m, 2 H, CH₂), 3.67 (s, 3 H, OCH₃), 3.79-3.86 (m, 1 H, CHNH), 4.04 (q, ³J_{H,H} = 8.3, 1 H, CHNH), 4.18 (d, ³J_{H,H} = 5.8, 1 H, OCH₂), 4.21-4.28 (m, 1 H, OCH₂), 4.38 (dt, ³J_{H,H} = 3.2, ³J_{H,H} = 8.6, 1 H, OCH₂), 4.50 (dt, ³J_{H,H} = 3.4, ³J_{H,H} = 9.1, 1 H, OCH₂), 5.02 (s, 1 H, OCH), 5.09 (s, 1 H, OCH), 6.61 (d, ³J_{H,H} = 8.0, 1 H, NH), 7.22 (d, ³J_{H,H} = 8.5, 2 H, Ar-CH), 7.30 (d, ³J_{H,H} = 8.5, 2 H, Ar-CH), 7.38 (d, ³J_{H,H} = 6.0, 2 H, Ar-CH), 7.40 (d, ³J_{H,H} = 6.0, 2 H, Ar-CH). – **¹³C-NMR** (75 MHz, MeOH-*d*₄): δ = 18.7 (+, 1 C, Val-CH₃), 18.8 (+, 1 C, Val-CH₃), 19.1 (+, 1 C, Val-CH₃), 20.1 (+, 1 C, Val-CH₃), 32.9 (+, 1 C, Val-CH), 33.2 (+, 1 C, Val-CH), 36.8 (-, 2 C, CH₂), 52.8 (+, 1 C, OCH₃), 59.3 (+, 1 C, CHNH), 60.0 (+, 1 C, CHNH), 67.4 (-, 1 C, OCH₂), 68.7 (-, 1 C, OCH₂), 69.1 (C_{quat}, 1 C, CNH), 71.5 (C_{quat}, 1 C, CNH), 85.8 (+, 1 C, OCH), 86.4 (+, 1 C, OCH), 123.1 (C_{quat}, 1 C, CBr), 123.8 (C_{quat}, 1 C, CBr), 129.4 (+, 2 C, Ar-CH), 129.6 (+, 2 C, Ar-CH), 132.3 (+, 2 C, Ar-CH), 132.5 (+, 2 C, Ar-CH), 134.9 (C_{quat}, 1 C, Ar-C), 138.0 (C_{quat}, 1 C, Ar-C), 168.9 (C_{quat}, 1 C, CO), 171.2 (C_{quat}, 1 C, CO), 172.9 (C_{quat}, 2 C, CO). – **MS** (ES, DCM/MeOH + 10 mmol/l NH₄OAc): *m/z* (%) = 765.1 (100) [MH⁺]. – **IR** (neat) [cm⁻¹]: $\tilde{\nu}$ = 3290, 2964, 2872, 2362, 2341, 1749, 1679, 1646, 1519, 1483, 1155, 1077, 1014, 841. – **MF** C₃₃H₄₂Br₂N₄O₇*HCl. – **MW** 802:98.

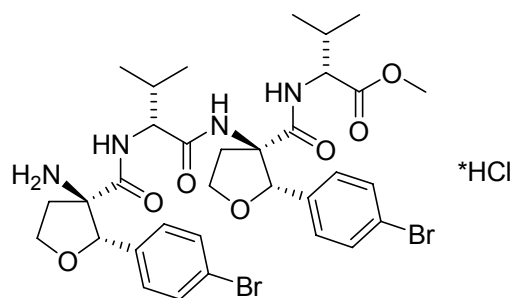

(R)-Methyl 2-((2S,3R)-3-((R)-2-((2S,3R)-3-amino-2-(4-bromophenyl)-tetrahydrofuran-3-carboxamido)-3-methylbutanamido)-2-(4-bromophenyl)-tetrahydrofuran-3-carboxamido)-3-methylbutanoate · HCl (193):

Compound **177** (140 mg, 0.16 mmol) was dissolved under ice bath cooling at 0 °C in dichloromethane. To this solution 1.1 ml ice cold HCl saturated ether (7 ml/mmol Boc) was added and the mixture was stirred over night at room temperature. The solvent was removed under reduced pressure to give the HCl salt of the product as white hygroscopic solid in quantitative yield (129 mg, 0.16 mmol). No further purification was necessary.

MP > 180 °C. – **¹H-NMR** (300 MHz, MeOH-*d*₄): δ = 0.70 (d, ³J_{H,H} = 6.9, 3 H, Val-CH₃), 0.81 (d, ³J_{H,H} = 6.9, 3 H, Val-CH₃), 0.94 (d, ³J_{H,H} = 6.9, 3 H, Val-CH₃), 0.97 (d, ³J_{H,H} = 6.9, 3 H, Val-CH₃), 1.74 (septet, ³J_{H,H} = 6.7, 1 H, Val-CH), 2.13 (septet, ³J_{H,H} = 6.4, 1 H, Val-CH), 2.32-2.45 (m, 1 H, CH₂), 2.52 (ddd, ³J_{H,H} = 3.7, ³J_{H,H} = 8.4, ²J_{H,H} = 14.1, 1 H, CH₂), 2.76-3.01 (m, 2 H, CH₂), 3.62 (s, 3 H, OCH₃), 3.80-3.89 (m, 1 H, CHNH), 4.02 (q, ³J_{H,H} = 7.9, 1 H, CHNH), 4.16 (d, ³J_{H,H} = 5.8, 1 H, OCH₂), 4.23 (q, ³J_{H,H} = 8.8, 1 H, OCH₂), 4.40 (t, ³J_{H,H} = 7.8, 1 H, OCH₂), 4.49 (dt, ³J_{H,H} = 3.4, ³J_{H,H} = 9.1, 1 H, OCH₂), 5.06 (s, 1 H, OCH), 5.14 (s, 1 H, OCH), 7.22 (d, ³J_{H,H} = 8.2, 2 H, Ar-CH), 7.30 (d, ³J_{H,H} = 8.5, 2 H, Ar-CH), 7.39 (d, ³J_{H,H} = 8.5, 2 H, Ar-CH), 7.41 (d, ³J_{H,H} = 8.2, 2 H, Ar-CH). – **¹³C-NMR** (75 MHz, MeOH-*d*₄): δ = 18.6 (+, 1 C, Val-CH₃), 19.1 (+, 1 C, Val-CH₃), 19.2 (+, 1 C, Val-CH₃), 20.1 (+, 1 C, Val-CH₃), 32.4 (+, 1 C, Val-CH), 33.3 (+, 1 C, Val-CH), 36.1 (-, 1 C, CH₂), 36.7 (-, 1 C, CH₂), 52.6 (+, 1 C, OCH₃), 59.5 (+, 1 C, CHNH), 60.0 (+, 1 C, CHNH), 67.4 (-, 1 C, OCH₂), 68.5 (-, 1 C, OCH₂), 69.2 (C_{quat}, 1 C, CNH), 71.9 (C_{quat}, 1 C, CNH), 86.1 (+, 1 C, OCH), 86.3 (+, 1 C, OCH), 123.1 (C_{quat}, 1 C, CBr), 123.9 (C_{quat}, 1 C, CBr), 129.6 (+, 2 C, Ar-CH), 129.9 (+, 2 C, Ar-CH), 132.2 (+, 2 C, Ar-CH), 132.7 (+, 2 C, Ar-CH), 134.9 (C_{quat}, 1 C, Ar-C), 138.3 (C_{quat}, 1 C, Ar-C), 168.8 (C_{quat}, 1 C, CO), 171.2 (C_{quat}, 1 C, CO), 172.7 (C_{quat}, 1 C, CO), 172.8 (C_{quat}, 1 C, CO). – **MS** (ES, DCM/MeOH + 10 mmol/l NH₄OAc): *m/z* (%) = 765.0 (100) [MH⁺], 787.0 (21) [MNa⁺]. – **IR** (neat) [cm⁻¹]: $\tilde{\nu}$ = 3398, 2956, 2526, 2361, 2343, 1728, 1672, 1510, 1489, 1436, 1212, 1072, 1006, 829, 801. – **MF** C₃₃H₄₂Br₂N₄O₇*HCl. – **MW** 802.98.

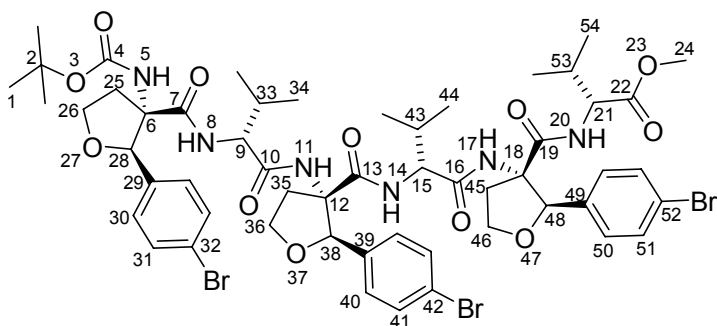

(R)-Methyl 2-((2R,3S)-2-(4-bromophenyl)-3-((R)-2-((2R,3S)-2-(4-bromophenyl)-3-((R)-2-((2R,3S)-2-(4-bromophenyl)-3-(tert-butoxycarbonylamino)-tetrahydrofuran-3-carboxamido)-3-methylbutanamido)-tetrahydrofuran-3-carboxamido)-3-methylbutanoate (175):

Under an atmosphere of nitrogen compound **188** (149 mg, 0.31 mmol, 1.4 eq.) was dissolved in 3.1 ml DMF (10 ml/mmol) and cooled to 0 °C in an ice bath. To the solution DIPEA (166 μ l, 0.97 mmol, 4.4 eq.), HOAt (66 mg, 0.48 mmol, 2.2 eq.) and HATU (184 mg, 0.48 mmol, 2.2 eq.) were added in this sequence. Then the amine **192** (177 mg, 0.22 mmol, 1.0 eq.) was slowly added in portions. The mixture was allowed to warm to room temperature and stirred for 24 hours. The reaction was quenched with 2 ml of water and 0.5 ml of 1M aqueous KHSO₄ and extracted with diethyl ether (3x5 ml). The combined organic layers were washed twice with brine. Afterwards the solution was dried over MgSO₄ and concentrated under reduced pressure. The crude product was then purified by column chromatography on flash silica gel (PE:diethyl ether 50:50, R_f = 0.21) to give the product as colorless solids with an overall yield of 35 % (96 mg, 0.078 mmol).

MP 100-112 °C. – **¹H-NMR** (600 MHz, COSY, ROESY, CDCl₃): δ = 0.58 (d, ³J_{H,H} = 7.0, 3 H, 34), 0.68 (d, ³J_{H,H} = 7.0, 3 H, 44), 0.76 (d, ³J_{H,H} = 7.0, 3 H, 34), 0.84 (d, ³J_{H,H} = 7.2, 3 H, 54), 0.85 (d, ³J_{H,H} = 7.7, 3 H, 44), 0.86 (d, ³J_{H,H} = 7.0, 3 H, 54), 1.52 (s, 9 H, 1), 1.98 (dq, ³J_{H,H} = 3.8, ³J_{H,H} = 6.9, 1 H, 33), 2.02-2.11 (m, 3 H, 35 + 43 + 53), 2.20 (ddd, ³J_{H,H} = 5.3, ³J_{H,H} = 8.4, ²J_{H,H} = 13.0, 1 H, 25), 2.36 (ddd, ³J_{H,H} = 3.5, ³J_{H,H} = 6.2, ²J_{H,H} = 13.3, 1 H, 45), 3.13-3.23 (m, 1 H, 45), 3.25 (t, ³J_{H,H} = 4.5, 1 H, 15), 3.32 (t, ³J_{H,H} = 3.4, 1 H, 9), 3.34 (dt, ²J_{H,H} = 12.5, ³J_{H,H} = 7.6, 1 H, 25), 3.59 (s, 3 H, 24), 3.62 (dt, ²J_{H,H} = 13.1, ³J_{H,H} = 8.4, 1 H, 35), 3.87-3.96 (m, 2 H, 36 + 46), 4.06-4.14 (m, 1 H, 21), 4.16 (dd, ³J_{H,H} = 8.4, ²J_{H,H} = 15.6, 1 H, 26), 4.35 (dt, ³J_{H,H} = 3.4, ³J_{H,H} = 8.0, 1 H, 46), 4.39-4.47 (m, 2 H, 26 + 36), 4.76 (s, 1 H, 28), 5.07 (s, 1 H, 38), 5.18 (s, 1 H, 48), 5.89 (d, ³J_{H,H} = 3.5, 1 H, 8), 6.22 (s, 1 H, 5), 6.88 (d, ³J_{H,H} = 4.2, 1 H, 14), 7.16 (d, ³J_{H,H} = 8.4, 2 H, 30), 7.27 (d, ³J_{H,H} = 7.5, 2 H, 51), 7.30-7.36 (m, 7 H, 20 + 40 + 41 + 50), 7.45 (s, 1 H, 17), 7.49 (d, ³J_{H,H} = 8.6, 2 H, 31), 7.99 (s, 1 H, 11). – **¹³C-NMR** (150 MHz, HSQC, HMBC, CDCl₃): δ = 16.5 (+, 1 C, 44), 17.0 (+, 1 C, 34), 18.3 (+, 1 C, 54), 18.6 (+, 1 C, 44), 18.9 (+, 1 C, 34), 19.1 (+, 1 C, 54),

28.4 (+, 3 C, 1), 29.0 (+, 1 C, 33 + 43), 31.5 (+, 1 C, 53), 36.5 (-, 1 C, 45), 36.5 (-, 1 C, 25), 38.0 (-, 1 C, 35), 51.5 (+, 1 C, 24), 57.7 (+, 1 C, 21), 60.3 (+, 1 C, 9), 61.7 (+, 1 C, 15), 67.9 (-, 1 C, 26), 68.5 (-, 1 C, 46), 68.6 (-, 1 C, 36), 70.5 (C_{quat}, 1 C, 6), 70.9 (C_{quat}, 1 C, 12), 71.1 (C_{quat}, 1 C, 18), 83.0 (C_{quat}, 1 C, 2), 86.6 (+, 1 C, 38), 68.7 (+, 1 C, 28), 87.4 (+, 1 C, 48), 121.5 (C_{quat}, 1 C, 52), 122.5 (C_{quat}, 1 C, 42), 123.4 (C_{quat}, 1 C, 32), 128.0 (+, 2 C, 30), 128.8 (+, 2 C, 40), 129.1 (+, 2 C, 50), 130.4 (+, 2 C, 51), 131.0 (+, 2 C, 41), 131.8 (+, 2 C, 31), 135.3 (C_{quat}, 1 C, 29), 136.4 (C_{quat}, 1 C, 39), 137.4 (C_{quat}, 1 C, 49), 156.8 (C_{quat}, 1 C, 4), 169.4 (C_{quat}, 1 C, 19), 170.9 (C_{quat}, 1 C, 13), 170.9 (C_{quat}, 1 C, 7), 171.5 (C_{quat}, 1 C, 22), 171.7 (C_{quat}, 1 C, 16), 171.9 (C_{quat}, 1 C, 10). – **MS** (ES, DCM/MeOH + 10 mM NH₄OAc): *m/z* (%) = 1231.7 (100) [MH⁺], 1248.7 (34) [MNH₄⁺]; 1155.4 (100) [M – H⁺ – tBuOH], 1229.6 (89) [M – H⁺]. – **IR** (neat) [cm⁻¹]: $\tilde{\nu}$ = 3252, 3312, 3240, 2967, 2941, 2887, 2359, 2332, 1735, 1657, 1595, 1519, 1462, 1259, 1121, 1007, 989, 826. – **MF** C₅₄H₆₉Br₃N₆O₁₂. – **MW** 1233.87.

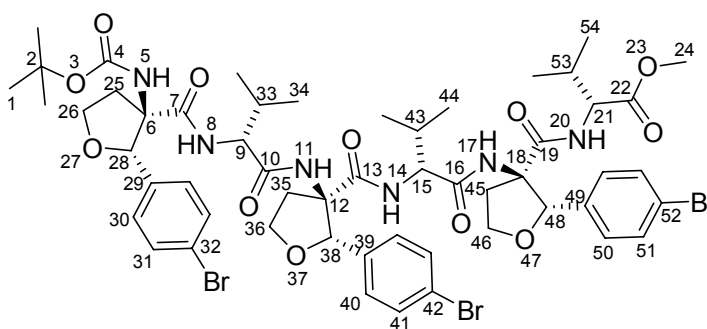

(R)-Methyl 2-((2S,3R)-2-(4-bromophenyl)-3-((R)-2-((2S,3R)-2-(4-bromophenyl)-3-((R)-2-((2S,3R)-2-(4-bromophenyl)-3-(tert-butoxycarbonylamino)-tetrahydrofuran-3-carboxamido)-3-methylbutanamido)-tetrahydrofuran-3-carboxamido)-3-methylbutanoate (178):

Under an atmosphere of nitrogen compound **190** (116 mg, 0.24 mmol, 1.4 eq.) was dissolved in 2.4 ml DMF (10 ml/mmol) and cooled to 0 °C in an ice bath. To the solution DIPEA (128 μ l, 0.75 mmol, 4.4 eq.), HOAt (51 mg, 0.37 mmol, 2.2 eq.) and HATU (124 mg, 0.37 mmol, 2.2 eq.) were added in this sequence. Then the amine **193** (137 mg, 0.17 mmol, 1.0 eq.) was slowly added in portions. The mixture was allowed to warm to room temperature and stirred for 24 hours. The reaction was quenched with 2 ml of water and 0.5 ml of 1M aqueous KHSO₄ and extracted with diethyl ether (3x5 ml). The combined organic layers were washed twice with brine. Afterwards the solution was dried over MgSO₄ and concentrated under reduced pressure. The crude product was then purified by column chromatography on flash silica gel (PE:diethyl ether 50:50, R_f = 0.29) to give the product as colorless solids with an overall yield of 23 % (49 mg, 0.04 mmol).

MP 248-249 °C. – ¹H-NMR (600 MHz, COSY, ROESY, CDCl₃): δ = 0.59 (d, ³J_{H,H} = 7.0, 3 H, 34), 0.62 (d, ³J_{H,H} = 7.0, 3 H, 54), 0.67 (d, ³J_{H,H} = 7.0, 3 H, 44), 0.70 (d, ³J_{H,H} = 6.8, 3 H, 54), 0.77 (d, ³J_{H,H} = 7.0, 3 H, 34), 0.87 (d, ³J_{H,H} = 7.0, 3 H, 44), 1.51 (s, 9 H, 1), 1.65 (sextet, ³J_{H,H} = 6.5, 1 H, 53), 1.97-2.06 (m, 2 H, 33 + 35), 2.09-2.16 (m, 1 H, 43), 2.21 (ddd, ³J_{H,H} = 5.2, ³J_{H,H} = 8.0, ²J_{H,H} = 12.9, 1 H, 25), 2.32 (ddd, ³J_{H,H} = 3.6, ³J_{H,H} = 6.1, ²J_{H,H} = 13.3, 1 H, 45), 3.23 (dt, ²J_{H,H} = 13.5, ³J_{H,H} = 8.6, 1 H, 45), 3.31-3.38 (m, 4 H, 9 + 15 + 25 + 35), 3.54 (t, ³J_{H,H} = 6.2, 1 H, 21), 3.61 (s, 3 H, 24), 3.83 (quartett, ³J_{H,H} = 8.1, 1 H, 36), 3.93 (dt, ³J_{H,H} = 7.0, ³J_{H,H} = 8.6, 1 H, 46), 4.17 (q, ³J_{H,H} = 7.6, 1 H, 26), 4.33 (dt, ³J_{H,H} = 3.4, ³J_{H,H} = 8.0, 1 H, 46), 4.37 (dt, ³J_{H,H} = 3.5, ³J_{H,H} = 8.4, 1 H, 26), 4.41 (dt, ³J_{H,H} = 5.5, ³J_{H,H} = 8.4, 1 H, 26), 4.77 (s, 1 H, 28), 5.06 (s, 1 H, 38), 5.16 (s, 1 H, 48), 5.93 (d, ³J_{H,H} = 5.9, 1 H, 8), 6.15 (s, 1 H, 5), 6.88 (d, ³J_{H,H} = 2.9, 3 H, 14), 7.18 (d, ³J_{H,H} = 8.4, 2 H, 30), 7.30 (d, ³J_{H,H} = 8.4, 2 H, 40), 7.32 (d, ³J_{H,H} = 8.4, 2 H, 51), 7.37 (d, ³J_{H,H} = 8.4, 2 H, 41), 7.41 (d, ³J_{H,H} = 8.4, 2 H, 50), 7.52 (s, 1 H, 17), 7.50 (d, ³J_{H,H} = 7.1, 2 H, 31), 7.55 (s, 1 H, 20), 7.99 (s, 1 H,

11). – $^{13}\text{C-NMR}$ (150 MHz, HSQC, HMBC, CDCl_3): δ = 16.3 (+, 1 C, 44), 17.0 (+, 1 C, 34), 18.4 (+, 1 C, 44), 18.5 (+, 1 C, 54), 18.6 (+, 1 C, 54), 18.9 (+, 1 C, 34), 28.4 (+, 3 C, 1), 29.0 (+, 1 C, 33), 29.2 (+, 1 C, 43), 29.9 (+, 1 C, 53), 36.6 (-, 1 C, 25), 37.4 (-, 1 C, 45), 37.8 (-, 1 C, 35), 51.5 (+, 1 C, 24), 59.3 (+, 1 C, 21), 60.3 (+, 1 C, 15), 61.3 (+, 1 C, 9), 67.9 (-, 1 C, 26), 68.1 (-, 1 C, 36), 68.2 (-, 1 C, 46), 70.5 (C_{quat} , 1 C, 6), 70.8 (C_{quat} , 1 C, 12), 71.3 (C_{quat} , 1 C, 18), 82.9 (C_{quat} , 1 C, 2), 86.6 (+, 1 C, 38), 86.7 (+, 1 C, 28), 87.3 (+, 1 C, 48), 121.8 (C_{quat} , 1 C, 52), 122.6 (C_{quat} , 1 C, 22), 123.4 (C_{quat} , 1 C, 32), 128.0 (+, 2 C, 30), 128.8 (+, 2 C, 40), 129.6 (+, 2 C, 50), 130.7 (+, 2 C, 51), 131.0 (+, 2 C, 41), 131.8 (+, 2 C, 31), 135.3 (C_{quat} , 1 C, 29), 136.2 (C_{quat} , 1 C, 39), 137.8 (C_{quat} , 1 C, 49), 156.8 (C_{quat} , 1 C, 4), 170.4 (C_{quat} , 1 C, 13), 170.6 (C_{quat} , 1 C, 19), 171.0 (C_{quat} , 1 C, 7), 171.7 (C_{quat} , 1 C, 22), 171.8 (C_{quat} , 1 C, 16), 172.2 (C_{quat} , 1 C, 10). – **MS** (ES, DCM/MeOH + 10 mM NH_4OAc): m/z (%) = 1231.5 (100) [MH^+]; 1155.2 (48) [$\text{M} - \text{H}^+ - \text{tBuOH}$], 1229.6 (100) [$\text{M} - \text{H}^+$], 1275.5 (95) [$\text{M} + \text{HCOO}$]. – **IR** (neat) [cm^{-1}]: $\tilde{\nu}$ = 3402, 2961, 2526, 2361, 2342, 1727, 1669, 1513, 1488, 1439, 1209, 1071, 1005, 829, 804. – **MF** $\text{C}_{54}\text{H}_{69}\text{Br}_3\text{N}_6\text{O}_{12}$. – **MW** 1233.87.

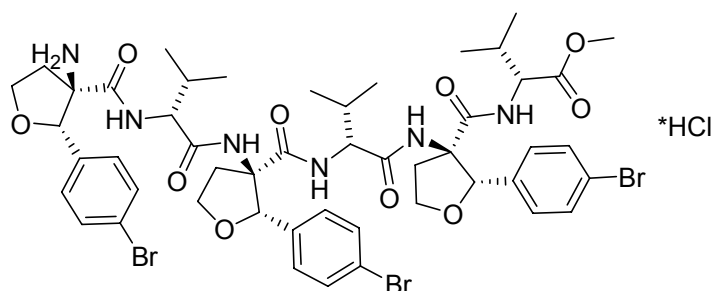

(R)-Methyl 2-((2S,3R)-3-((R)-2-((2S,3R)-3-((R)-2-((2S,3R)-3-amino-2-(4-bromophenyl)-tetrahydrofuran-3-carboxamido)-3-methylbutanamido)-2-(4-bromophenyl)-tetrahydrofuran-3-carboxamido)-3-methylbutanamido)-2-(4-bromophenyl)-tetrahydrofuran-3-carboxamido)-3-methylbutanoate · HCl (**194**):

Compound **178** (200 mg, 0.16 mmol) was dissolved under ice bath cooling at 0 °C in dichloromethane. To this solution 1.1 ml ice cold HCl saturated ether (7 ml/mmol Boc) was added and the mixture was stirred over night at room temperature. The solvent was removed under reduced pressure to give the HCl salt of the product as white hygroscopic solid in quantitative yield (190 mg, 0.16 mmol). No further purification was necessary.

MP > 180 °C. – $^1\text{H-NMR}$ (400 MHz, COSY, $\text{MeOH-}d_4$): δ = 0.76 (d, $^3J_{\text{H,H}}$ = 6.6, 6 H, Val- CH_3), 0.86 (d, $^3J_{\text{H,H}}$ = 6.6, 3 H, Val- CH_3), 0.88 (d, $^3J_{\text{H,H}}$ = 6.8, 3 H, Val- CH_3), 0.94 (d, $^3J_{\text{H,H}}$ = 6.7, 3 H, Val- CH_3), 1.00 (d, $^3J_{\text{H,H}}$ = 6.6, 3 H, Val- CH_3), 1.80 (septet, $^3J_{\text{H,H}}$ = 6.8, 1 H, Val-CH), 1.87-1.99 (m, 1 H, Val-CH), 2.10 (ddd, $^3J_{\text{H,H}}$ = 3.1, $^3J_{\text{H,H}}$ = 7.0, $^2J_{\text{H,H}}$ = 13.0, 1 H, CH_2), 2.15-2.26 (m, 1 H, Val-CH), 2.28-2.36 (m, 1 H, CH_2), 2.46 (ddd, $^3J_{\text{H,H}}$ = 3.1, $^3J_{\text{H,H}}$ = 8.0,

$^2J_{H,H} = 14.0$, 1 H, CH₂), 2.85-3.00 (m, 2 H, CH₂), 3.20 (q, $^3J_{H,H} = 7.2$, 1 H, CH₂), 3.38 (d, $^3J_{H,H} = 4.4$, 1 H, CHNH), 3.54 (d, $^3J_{H,H} = 6.6$, 1 H, CHNH), 3.59 (s, 3 H, OCH₃), 3.79-3.88 (m, 1 H, OCH₂), 3.93-4.08 (m, 3 H, CHNH + OCH₂), 4.28 (dt, $^3J_{H,H} = 3.1$, $^3J_{H,H} = 8.8$, 1 H, OCH₂), 4.33 (dt, $^3J_{H,H} = 1.2$, $^3J_{H,H} = 8.7$, 1 H, OCH₂), 4.39 (dt, $^3J_{H,H} = 3.1$, $^3J_{H,H} = 8.4$, 1 H, OCH₂), 4.95 (s, 1 H, OCH), 5.31 (s, 1 H, OCH), 5.33 (s, 1 H, OCH), 7.23 (d, $^3J_{H,H} = 8.4$, 2 H, Ar-CH), 7.32 (d, $^3J_{H,H} = 8.6$, 2 H, Ar-CH), 7.34 (d, $^3J_{H,H} = 9.2$, 2 H, Ar-CH), 7.40 (d, $^3J_{H,H} = 8.6$, 2 H, Ar-CH), 7.42 (d, $^3J_{H,H} = 8.5$, 2 H, Ar-CH), 7.45 (d, $^3J_{H,H} = 8.3$, 2 H, Ar-CH). – **^{13}C -NMR** (100 MHz, MeOH-*d*₄): $\delta = 18.7$ (+, 1 C, Val-CH₃), 19.0 (+, 1 C, Val-CH₃), 19.1 (+, 1 C, Val-CH₃), 19.3 (+, 1 C, Val-CH₃), 19.8 (+, 1 C, Val-CH₃), 20.3 (+, 1 C, Val-CH₃), 31.0 (+, 1 C, Val-CH), 31.4 (+, 1 C, Val-CH), 33.1 (+, 1 C, Val-CH), 36.0 (-, 1 C, CH₂), 36.9 (-, 1 C, CH₂), 37.4 (-, 1 C, CH₂), 52.2 (+, 1 C, OCH₃), 60.6 (+, 1 C, CHNH), 60.8 (+, 1 C, CHNH), 62.3 (+, 1 C, CHNH), 67.3 (-, 1 C, OCH₂), 68.6 (-, 1 C, OCH₂), 68.8 (-, 1 C, OCH₂), 69.2 (C_{quat}, 1 C, CNH), 72.3 (C_{quat}, 1 C, CNH), 72.4 (C_{quat}, 1 C, CNH), 86.0 (+, 1 C, OCH), 86.3 (+, 1 C, OCH), 87.6 (+, 1 C, OCH), 123.0 (C_{quat}, 1 C, CBr), 123.5 (C_{quat}, 1 C, CBr), 123.9 (C_{quat}, 1 C, CBr), 129.4 (+, 2 C, Ar-CH), 130.0 (+, 2 C, Ar-CH), 130.2 (+, 2 C, Ar-CH), 131.9 (+, 2 C, Ar-CH), 132.3 (+, 2 C, Ar-CH), 132.6 (+, 2 C, Ar-CH), 135.2 (C_{quat}, 1 C, Ar-C), 138.3 (C_{quat}, 1 C, Ar-C), 138.9 (C_{quat}, 1 C, Ar-C), 169.2 (C_{quat}, 1 C, CO), 171.5 (C_{quat}, 1 C, CO), 172.2 (C_{quat}, 1 C, CO), 172.7 (C_{quat}, 1 C, CO), 172.8 (C_{quat}, 1 C, CO), 174.2 (C_{quat}, 1 C, CO). – **MS** (ES, DCM/MeOH + 10 mmol/l NH₄OAc): *m/z* (%) = 1131.4 (100) [MH⁺], 1153.4.0 (89) [MNa⁺]; 1129.2 (50) [M – H⁺], 1165.2 (100) [M + Cl⁻], 1243.4 (41) [M + TFA⁻]. – **IR** (neat) [cm⁻¹]: $\tilde{\nu} = 3401, 2955, 2526, 2365, 2339, 1728, 1672, 1511, 1488, 1436, 1213, 1072, 1004, 829, 799$. – **MF** C₄₉H₆₁Br₃N₆O₁₀*HCl. – **MW** 1170.22.

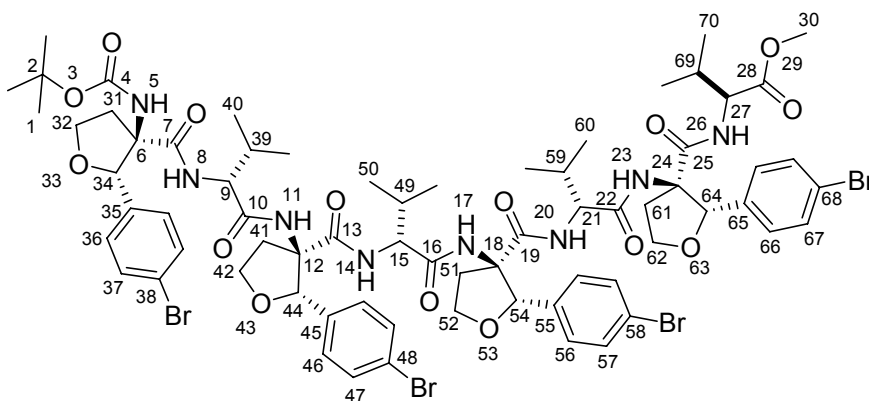

(R)-Methyl 2-((2S,3R)-2-(4-bromophenyl)-3-((R)-2-((2S,3R)-2-(4-bromophenyl)-3-((R)-2-((2S,3R)-2-(4-bromophenyl)-3-(tert-butoxycarbonylamino)-tetrahydrofuran-3-carboxamido)-3-methylbutanamido)-tetrahydrofuran-3-carboxamido)-3-methylbutanamido)-tetrahydrofuran-3-carboxamido)-3-methylbutanoate (**179**):

Under an atmosphere of nitrogen compound **190** (95 mg, 0.20 mmol, 1.4 eq.) was dissolved in 1.7 ml DMF (12 ml/mmol) and cooled to 0 °C in an ice bath. To the solution DIPEA (72 μ l, 0.42 mmol, 3.0 eq.), HOAt (29 mg, 0.21 mmol, 1.5 eq.) and HATU (80 mg, 0.21 mmol, 1.5 eq.) were added in this sequence. Then the amine **194** (164 mg, 0.16 mmol, 1.0 eq.) was slowly added in portions. The mixture was allowed to warm to room temperature and stirred for 24 hours. The reaction was quenched with 3 ml of water and 0.5 ml of 1M aqueous KHSO_4 and extracted with diethyl ether (3x5 ml). The combined organic layers were washed twice with brine. Afterwards the solution was dried over MgSO_4 and concentrated under reduced pressure. The crude product was then purified by column chromatography on flash silica gel (PE:EtOAc 50:50, $R_f = 0.21$) to give the product as colorless solids with an overall yield of 28 % (48 mg, 0.04 mmol).

$^1\text{H-NMR}$ (600 MHz, COSY, ROESY, $\text{DMSO-}d_6$): $\delta = 0.61$ (d, $^3J_{\text{H,H}} = 6.7$, 3 H, 70), 0.66-75 (m, 12 H, 40 + 60 + 70), 0.78 (d, $^3J_{\text{H,H}} = 7.1$, 3 H, 40), 0.79 (d, $^3J_{\text{H,H}} = 6.8$, 3 H, 50), 0.83 (d, $^3J_{\text{H,H}} = 6.9$, 3 H, 50), 1.49 (s, 9 H, 1), 1.83 (septet, $^3J_{\text{H,H}} = 7.1$, 1 H, 69), 1.86-1.94 (m, 2 H, 39 + 59), 1.96-2.03 (m, 1 H, 49), 2.04-2.20 (m, 4 H, 31 + 41 + 51 + 61), 2.82 (ddd, $^3J_{\text{H,H}} = 8.2$, $^3J_{\text{H,H}} = 10.7$, $^2J_{\text{H,H}} = 13.2$, 1 H, 61), 3.00 (t, $^3J_{\text{H,H}} = 5.1$, 1 H, 27), 3.02-3.11 (m, 5 H, 9 + 15 + 21 + 31 + 41), 3.23 (dt, $^2J_{\text{H,H}} = 13.3$, $^3J_{\text{H,H}} = 8.6$, 1 H, 51), 3.52 (s, 3 H, 30), 3.64 (ddd, $^3J_{\text{H,H}} = 6.1$, $^3J_{\text{H,H}} = 8.3$, $^3J_{\text{H,H}} = 10.8$, 1 H, 62), 3.78 (dd, $^3J_{\text{H,H}} = 7.3$, $^3J_{\text{H,H}} = 9.1$, 1 H, 42), 3.82 (dd, $^3J_{\text{H,H}} = 8.7$, $^2J_{\text{H,H}} = 16.5$, 1 H, 52), 3.99 (dd, $^3J_{\text{H,H}} = 8.2$, $^2J_{\text{H,H}} = 16.1$, 1 H, 32), 4.16-4.25 (m, 1 H, 32), 4.26-4.34 (m, 2 H, 42 + 52), 4.97 (s, 1 H, 64), 5.04 (s, 1 H, 54), 5.09 (s, 1 H, 34), 5.19 (s, 1 H, 44), 6.98 (d, $^3J_{\text{H,H}} = 5.5$, 20), 7.17 (d, $^3J_{\text{H,H}} = 8.4$, 2 H, 66), 7.20 (d, $^3J_{\text{H,H}} = 9.2$, 2 H, 26), 7.22-27 (m, 4 H, 36 + 46), 7.28-7.34 (m, 4 H, 56 + 67), 7.36 (d, $^3J_{\text{H,H}} = 8.6$, 2 H, 47), 7.40 (s, 1 H, 23), 7.42 (d, $^3J_{\text{H,H}} = 5.3$, 2 H, 57), 7.44 (d, $^3J_{\text{H,H}} = 5.4$, 2 H, 37), 7.83 (s, 1 H, 17), 8.07 (s, 1 H, 8), 8.29 (s, 1 H, 11), 8.36 (s, 1 H, 5). – **$^{13}\text{C-NMR}$** (150 MHz,

HSQC, HMBC, DMSO- d_6): δ = 17.3 (+, 1 C, 70), 17.7 (+, 1 C, 360), 17.8 (+, 1 C, 40), 18.2 (+, 2 C, 40 + 50), 18.3 (+, 1 C, 70), 18.7 (+, 1 C, 50), 18.8 (+, 1 C, 60), 28.1 (+, 3 C, 1), 28.4 (+, 1 C, 49), 28.8 (+, 1 C, 69), 28.9 (+, 1 C, 59), 30.7 (+, 1 C, 39), 33.3 (-, 1 C, 61), 36.0 (-, 1 C, 31), 36.4 (-, 1 C, 41), 36.6(-, 1C, 51), 51.3 (+, 1 C, 30), 57.3 (+, 1 C, 21), 61.2 (+, 2 C, 15 + 27), 61.7 (+, 1 C, 9), 67.2 (-, 2 C, 32 + 62), 67.5 (-, 1 C, 42), 67.8 (-, 1 C, 52), 70.3 (C_{quat}, 2 C, 18 + 25), 70.5 (C_{quat}, 1 C, 6), 70.6 (C_{quat}, 1 C, 12), 80.4 (C_{quat}, 1 C, 2), 84.4 (+, 1 C, 34), 85.4 (+, 2 C, 44 + 54), 86.0 (+, 1 C, 64), 120.7 (C_{quat}, 1 C, 68), 121.3 (C_{quat}, 1 C, 58), 121.4 (C_{quat}, 1 C, 38), 121.5 (C_{quat}, 1 C, 48), 128.8 (+, 2 C, 46), 128.9 (+, 4 C, 36 + 56), 129.0 (+, 2 C, 66), 130.0 (+, 2 C, 67), 130.5 (+, 4 C, 37 + 57), 130.6 (+, 2 C, 47), 136.8 (C_{quat}, 1 C, 45), 137.0 (C_{quat}, 1 C, 55), 137.2 (C_{quat}, 1 C, 35), 137.7 (C_{quat}, 1 C, 65), 156.8 (C_{quat}, 1 C, 4), 168.1 (C_{quat}, 1 C, 25), 170.2 (C_{quat}, 1 C, 19), 170.6 (C_{quat}, 2 C, 22 + 28), 170.9 (C_{quat}, 1 C, 13), 172.4 (C_{quat}, 1 C, 7), 172.5 (C_{quat}, 2 C, 10 +16). – **MS** (ES, DCM/MeOH + 10 mM NH₄OAc): m/z (%) = 799.1 (100) [MH⁺], 1597.5 (21) [MH⁺]; 1595.5 (100) [M – H⁺]. – **IR** (neat) [cm⁻¹]: $\tilde{\nu}$ = 3398, 2961, 2530, 2357, 2342, 1729, 1670, 1511, 1486, 1439, 1210, 1071, 1015, 829, 805. – **MF** C₇₀H₈₈Br₄N₈O₁₅. – **MW** 1601.01.

X-Ray structure and crystal data of **179**:

Monoclinic; space group: P 21; cell dimensions: $a = 10.9445(1) \text{ \AA}$, $\alpha = 90^\circ$, $b = 19.3924(1) \text{ \AA}$, $\beta = 104.032(1)^\circ$, $c = 17.9304(1) \text{ \AA}$, $\gamma = 90^\circ$; $V = 3692.00(5) \text{ \AA}^3$; $Z = 2$, $D_x = 1.440 \text{ Mg/m}^3$; $\mu = 3.223 \text{ mm}^{-1}$; $F(000) = 1648$. Data collection: $T = 123 \text{ K}$; graphite monochromator. A colorless crystal with dimensions of $0.212 \times 0.160 \times 0.131 \text{ mm}$ was used to measure 23708 reflections (12033 unique reflections, $R_{\text{int}} = 0.0221$) from 2.54° to 67.17° on a Oxford Diffraction Gemini Ultra diffractometer with the omega-scan method. Structure refinement: The F^2 value was refined using the full-matrix least squares refinement method, with a goodness-of-fit of 1.027 for all reflections and 886 parameters.

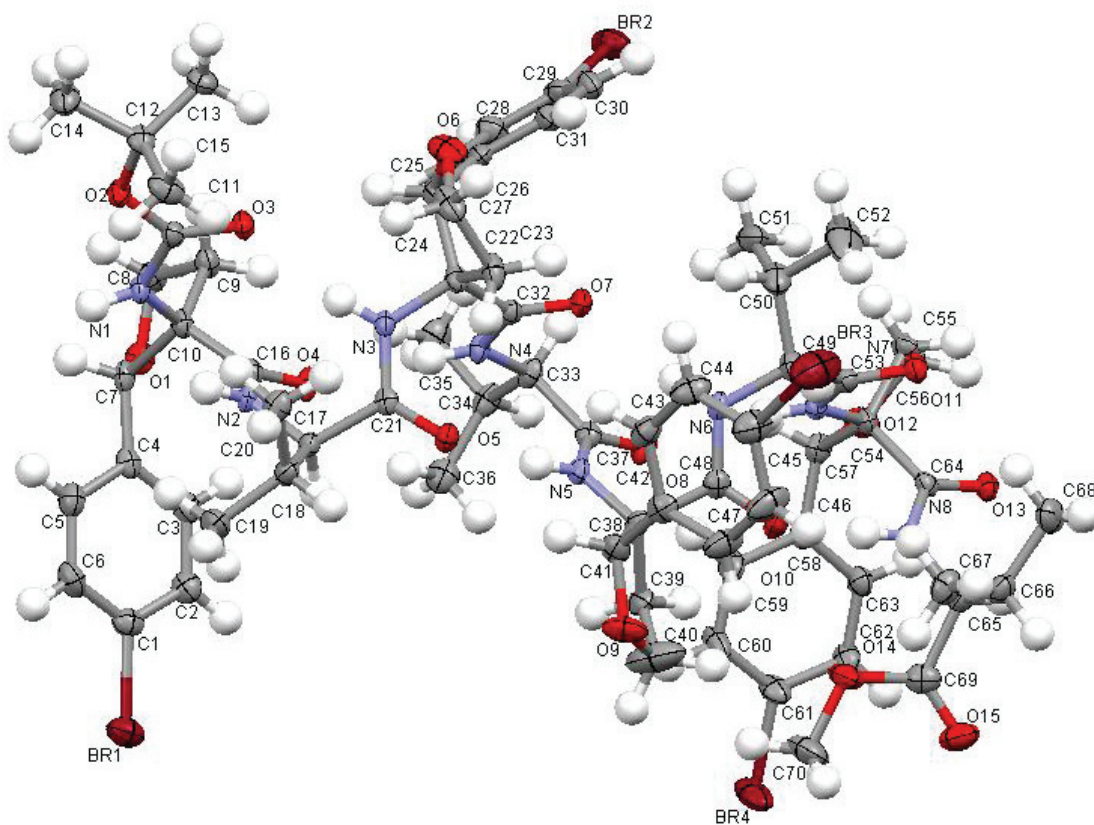

4. Derivatization of TAAs and the Synthesis of Cyclic Peptides

4.1. Introduction

The design and synthesis of small molecules which mimic natural peptide sequences have attracted much attention from organic, bioorganic and peptide chemists.^{222c, 123} This is due to numerous advantages of peptidomimetics over short natural sequences, such as greater steric constraints leading to a more pronounced secondary structure and the higher biological and chemical stability.^{125a, 212a}

Many different ways are known for the synthesis of peptidomimetics^{138, 199, 209, 219b} among which the preparation of cyclic peptides has received considerable attention. Cyclic peptides occur in a variety of natural bioactive compounds and they are of great interest for synthetic chemists and biologist, because they often show higher *in vivo* stability and reduced conformational mobility than their linear counterparts thus making them potential drug candidates.²⁴⁰ A large number of cyclic peptides was designed and synthesized in the last years with some being biologically active natural products,^{193, 194b} while others are mimics of natural peptide sequences like for example the large group of bio-active analogues of the natural RGD-sequence.^{192, 241} Additionally, different cyclic peptidomimetic inhibitors for enzymes like HIV 1 protease were developed and successfully tested for their activity.²⁴²

Another strategy to peptidomimetics with enhanced proteolytic stability compared to their natural analogues uses unnatural constrained amino acids like C^α-tetrasubstituted α -amino acids which are incorporated into the peptide sequence.^{227b} A large number of such unnatural cyclic or acyclic amino acids with and without a stereocenter at the C^α-carbon has been reported²¹⁶ and used in the synthesis of peptidomimetics resulting in stable helices²⁴³ and turn-like structures^{221b, c} of which some show biological activity.^{185, 222b, d, 229c} One example of such a cyclic C^α-tetrasubstituted α -amino acid is the tetrahydrofuran derivative *rac*-**135** developed in our group, which introduces β -turn structures in tripeptides.²¹⁸ Despite the many known examples of cyclic α -amino acids and their applications as structure inducing elements in peptide strands,^{222a} to the best of our knowledge cyclic C^α-tetrasubstituted α -amino acids have not been used in the synthesis of cyclic peptidomimetics so far.

Hence, we developed a general methodology for the Cu(I)-catalyzed N-arylation reaction of the C^α-tetrasubstituted tetrahydrofuran amino acid *rac*-**135** with a variety of different amines and used it to link the N-terminus of a tripeptide with the side chain aryl halide of

rac-**135** incorporated in the sequence (Scheme 25, **1** → **2**). A cyclic tripeptide mimetic containing an aromatic ether²⁴⁴ was obtained by an O-arylation reaction using palladium catalysis (Scheme 25, **3** → **4**).

Scheme 25: Synthesis of cyclic peptide mimics by an N-arylation reaction using Cu(I) (top) or by an O-arylation reaction using Pd(0) (bottom).

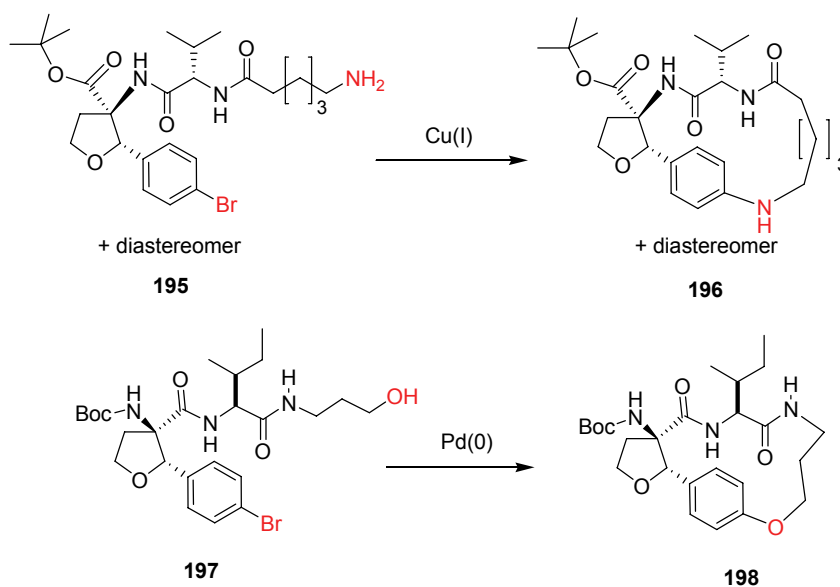

4.2. Synthesis

4.2.1. Development of the CuI-Catalysis Reaction Conditions

Initially, we explored the scope for CuI-catalyzed reactions of the unnatural amino acid *rac*-**135** with aliphatic benzylamine (Scheme 26). Previous studies served as a starting point for the optimization experiments.^{230a, 245} The ligands *L*-proline **A** and *N,N*-dimethylglycine **B** were found to be good promoters for the CuI-catalyzed reaction. K₃PO₄ and K₂CO₃ were found to be suitable bases. In Table 5, entries 1 to 6 summarize the reaction conditions for the model reaction of benzylamine with the unnatural amino acid *rac*-**135**. These results illustrate that when using K₃PO₄ as base with 10 mol% of catalyst and 20 mol% ligand **A** at 100 °C, a yield of about 50 % was obtained. The use of larger amounts of CuI in combination with ligand **A** gave no better results. Decreasing the temperature to about 50 °C resulted in no product formation (entry 3). A significant increase in yield by about 20 % was obtained when the base was changed from K₃PO₄ to the more basic K₂CO₃ (entry 4). A substitution of ligand **A** by ligand **B** while retaining the other conditions, gave the same amount of product (entries 4 and 5).

Scheme 26: C-N bond formation reactions catalyzed by a combination of CuI and *L*-amino acids.

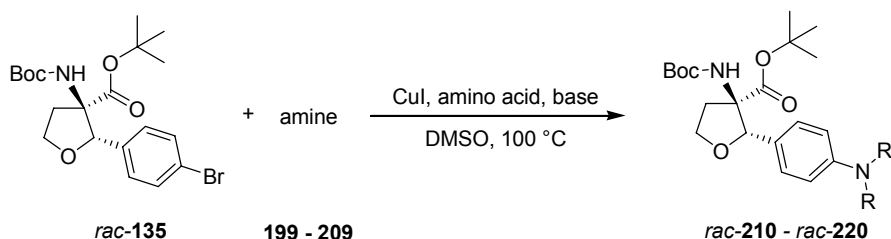





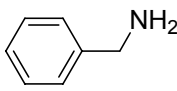
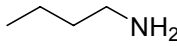
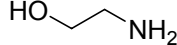

Following the development of appropriate reaction conditions, several different amines were coupled under these conditions to elucidate the scope of the CuI catalyzed reaction. In entries 6 to 9 three different primary amines with and without functional groups were used. Butylamine was coupled in good yields to *rac*-**135**. The reaction was conducted at a tenfold higher dilution as a test of the cyclisation reactions for which a higher dilution is necessary to promote the intramolecular cyclisation reaction and to avoid polymerization. The product was obtained, although in poor yield. Entry 8 shows that 2-aminoethanol selectively undergoes the N-arylation reaction without an adverse effect of the unprotected hydroxyl moiety of the amino alcohol. This reaction and entry 9 show that also amines containing different functional groups are compatible with the applied reaction conditions. Another example is shown in entry 21 where a mono Cbz-protected alkyl

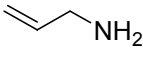
diamine was successfully coupled introducing a second amine functionality with an orthogonal protecting group. Secondary amines were also tried as reaction partners for the amino acid *rac*-**135** but their increased steric hindrance decreased their reactivity: diethylamine (entries 10 to 12) showed no conversion. Neither the change from ligand **A** to **B** nor from the base K_2CO_3 to K_3PO_4 gave any product. Morpholine (entries 13 and 14) gave about 30 % product yield. The yield did not increase with larger amounts of catalyst and ligand. Pyrrolidine (entry 15) gave over 70 % yield. The reactivity of diethyl amine and pyrrolidine differ significantly which is explained by the different geometry of the two amines.^{230a} The formation of diarylamines was examined using *p*-anisidine together with 10 mol% CuI which gave the diphenylamine in about 50 % yield. The heterocyclic imidazole was coupled to *rac*-**135** under CuI catalysis giving the product in 45 % yield when using 10 mol% CuI and in a slightly higher yield when using 30 mol% CuI. Furthermore, amino acid esters can be coupled in the Ullmann-type reaction in moderate yields. The amino acid ester hydrochloride must be neutralized by extraction under basic conditions using a sat. aqueous $NaHCO_3$ solution and ethyl acetate prior to use, because the salt itself was found to be unreactive under the applied reaction conditions even with large excess of an inorganic base (entries 19 and 20).

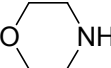
Table 5: CuI catalyzed C-N bond formation reaction conditions and yields.

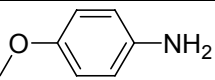
entry	amine	CuI (eq.)	ligand	base	product	yield (%)
1		0.1	A	K_3PO_4		49*
2		0.2	A	K_3PO_4		47*
3		0.1	A	K_3PO_4	<i>rac</i> - 210 , R = benzyl, R' = H	- ^a
4	199	0.1	A	K_2CO_3		70
5		0.1	B	K_2CO_3		70
6		0.1	A	K_3PO_4	<i>rac</i> - 211 ,	65*
7	200	0.1	A	K_3PO_4	R = Bu, R' = H	12*, ^b
8		0.1	A	K_2CO_3	<i>rac</i> - 212 , R = C_2H_4OH , R' = H	42*
	201					

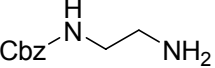
entry	amine	Cul (eq.)	ligand	base	product	yield (%)
9	 202	0.1	A	K ₂ CO ₃	<i>rac</i> - 213 , R = allyl, R' = H	54*
10	 203	0.1	A	K ₂ CO ₃	<i>rac</i> - 214 , R, R' = Et	-*
11		0.1	A	K ₃ PO ₄		-*
12		0.1	B	K ₂ CO ₃		-
13	 204	0.1	A	K ₂ CO ₃	<i>rac</i> - 215 ,	31
14		0.3	A	K ₂ CO ₃	R-R' = O(C ₂ H ₄) ₂	33*
15	 205	0.1	A	K ₂ CO ₃	<i>rac</i> - 216 , R-R' = C ₄ H ₈	73*
16	 206	0.1	A	K ₂ CO ₃	<i>rac</i> - 217 , R = p-MeO-C ₆ H ₄ , R' = H	49*
17	 207	0.1	A	K ₂ CO ₃	<i>rac</i> - 218 ,	45*
18		0.3	A	K ₂ CO ₃	NRR' = imidazole	49*
19	H-Gly-OMe*HCl 208-HCl	0.1	A	K ₂ CO ₃	-	-*c)
20	H-Gly-OMe 208	0.1	A	K ₂ CO ₃	<i>rac</i> - 219 , R = Gly-Ome, R' = H	13
21	 209	0.1	A	K ₂ CO ₃	<i>rac</i> - 220 , R = C ₂ H ₄ NHCbz, R' = H	23

All reactions except the ones indicated were performed using 1 eq. *rac*-**135**, 1.5 eq. amine, 2 eq. base, 10 mol% Cul (based on the *rac*-**135**), 20 mol% ligand (based on the *rac*-**135**), dry DMSO, concentration of *rac*-**135** c = 1M, 100 °C, 48 hours

a) carried out at 50 °C

b) the reaction was performed at a concentration of *rac*-**135** C = 1M in dry DMSO

c) the reaction was performed using 4 eq. of base

* Reactions were carried out in collaboration with A. Späth at the Shanghai Institute For Organic Chemistry (SIOC) under the supervision of Prof. D. Ma.

All reactions shown in Table 5 were performed under conventional heating in an oil bath and required about 2 days to come to completion. Microwave irradiation has been used as an alternative energy input, reducing the required reaction time in some cases.²⁴⁶ For CuI promoted C-N bond formations, one example of microwave heating was reported.²⁴⁷

Table 6: CuI catalyzed C-N bond formation reactions using microwave heating..

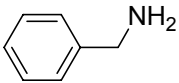
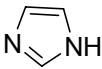
entry	amine	CuI (eq.)	ligand	base, eq.	product	yield (%)
1		0.1	A	K ₃ PO ₄ , 2.0 eq.		-
2		0.1	A	K ₂ CO ₃ , 2.0 eq.	<i>rac</i> - 210 , R = benzyl,	-
3	199	0.1	A	K ₂ CO ₃ , 0.2 eq.	R' = H	10 ^a
4		0.1	A	K ₂ CO ₃ , 0.5 eq.		15
5		0.1	A	K ₂ CO ₃ , 2.0 eq.	<i>rac</i> - 218 ,	-
6	207	0.1	A	K ₂ CO ₃ , 0.2 eq.	NRR' = imidazole	-

All reactions except the ones indicated were performed using 1 eq. *rac*-**135**, 1 eq. amine, 10 mol% CuI (based on *rac*-**135**), 20 mol% ligand (Based on *rac*-**135**), 1 ml/mmol (*rac*-**135**) dry DMSO, 160 °C, 20 minutes

^a reaction was carried out a second time with 60 minutes of microwave irradiation without any effect

In Table 6 the results from the microwave experiments are summarized. The first reactions (entries 1, 2 and 5) were carried out using the same equivalents of base as for the reactions shown in Table 5. Those reactions gave no product. Accordingly, the amount of base was reduced to 0.2 eq., the same amount which was used by Veverková *et al.*²⁴⁷ The coupling with imidazole **207** (entry 6) gave again no product but at least a small amount was obtained when using benzyl amine **199** (entry 3). This reaction was then repeated with a longer reaction time of 60 minutes instead of 20 minutes as for all other experiments but with no measurable improvement of the yield. As a last experiment (entry 4) the amount of base was increased to 0.5 eq. which altered the yield to 15 %. However, this is still far less than for the ones using conventional heating and the longer reaction time.

Based on the results shown in Table 5 it was decided to try to use sterically more demanding secondary amines which comprise functional groups and can be used for example for the complexation of metal ions like Zn(II) or Cu(II) and with that in molecular recognition. Therefore some metal catalyzed reactions using mostly the system CuI/*L*-proline **A** but also CuI/cyclohexane-1,2-diamine **C** (Table 7) Boc-cyclen **223**. As none of these experiments showed success one attempt was conducted using Pd(OAc)₂ together with PPh₃ **D** as ligand, but again no product was formed. In contrast to all other reactions, for the ones where 3-Boc-cyclen **223** was used as amine, the Cbz-TAA-O^tBu *rac*-**140** was used to offer orthogonality between the protecting groups of the amino acid and the side chain amines of the cyclen.

Table 7: C-N bond formation reactions using metal ligand precursors.

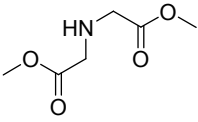
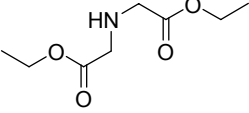
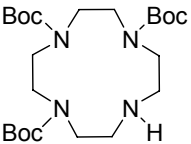
entry	ArX	amine	metal salt	ligand	base	yield (%)
1	<i>rac</i> - 135		CuI, 0.1 eq.	A	K ₃ PO ₄	-
2			CuI, 0.2 eq.	A	K ₃ PO ₄	-
3	<i>rac</i> - 135		CuI, 0.2 eq.	A	K ₃ PO ₄	-
4	<i>rac</i> - 140		CuI, 0.1 eq.	A	K ₃ PO ₄	-
5			CuI, 0.1 eq.	C	K ₃ PO ₄	-
6			Pd(OAc) ₂ , 0.1 eq.	D	NaO ^t Bu	-

In summary, it can be noted that it is possible to couple a variety of different mono- or dialkylated amines to *rac*-**135** by the use of 10 mol% CuI as catalyst in combination with *L*-amino acids as ligands. In addition to simple alkyl amines, this methodology offers the possibility to replace the bromine substituent of *rac*-**135** by different functional groups like protected amines and carboxylic acids, but also by unprotected alcohol functionalities, aromatic and heteroaromatic compounds or olefin moieties. The reactions gave the products in moderate to good yields of up to 70 %.

4.2.2. Synthesis of Cyclic Tripeptide Mimics via C-N Arylation

To demonstrate the use of the developed C-N bond formation conditions in cyclisation reactions, the cyclic tripeptide **196** and its diastereomer were synthesized applying the developed C-N bond formation reactions. A 15-membered ring system should result from the reaction of unnatural amino acid *rac*-**135**, *L*-valine **226** and 4-aminobutanoic acid **224**, while a 17-membered ring is expected if 6-aminohexanoic acid **225** was used instead of 4-aminobutanoic acid **224**. Both tripeptides were synthesized using standard peptide coupling reactions starting from the Boc-protected amino acids **224** or **225** which were coupled with *L*-valine methyl ester **226** to afford the dipeptides **227** and **228**.

Scheme 27: Reaction sequence leading to the cyclic tripeptides **196** and **234**: a) DIPEA, EDC, HOBt, dry DMF, 24h, rt; b) LiOH, water/THF, 24h, rt; c) HCl sat. diethyl ether, DCM, 24h, rt; d) 8 % TFA, dry DCM, 3-4h, rt; e) CuI, *L*-proline, K₂CO₃, DMSO, 48 h, 100 °C.

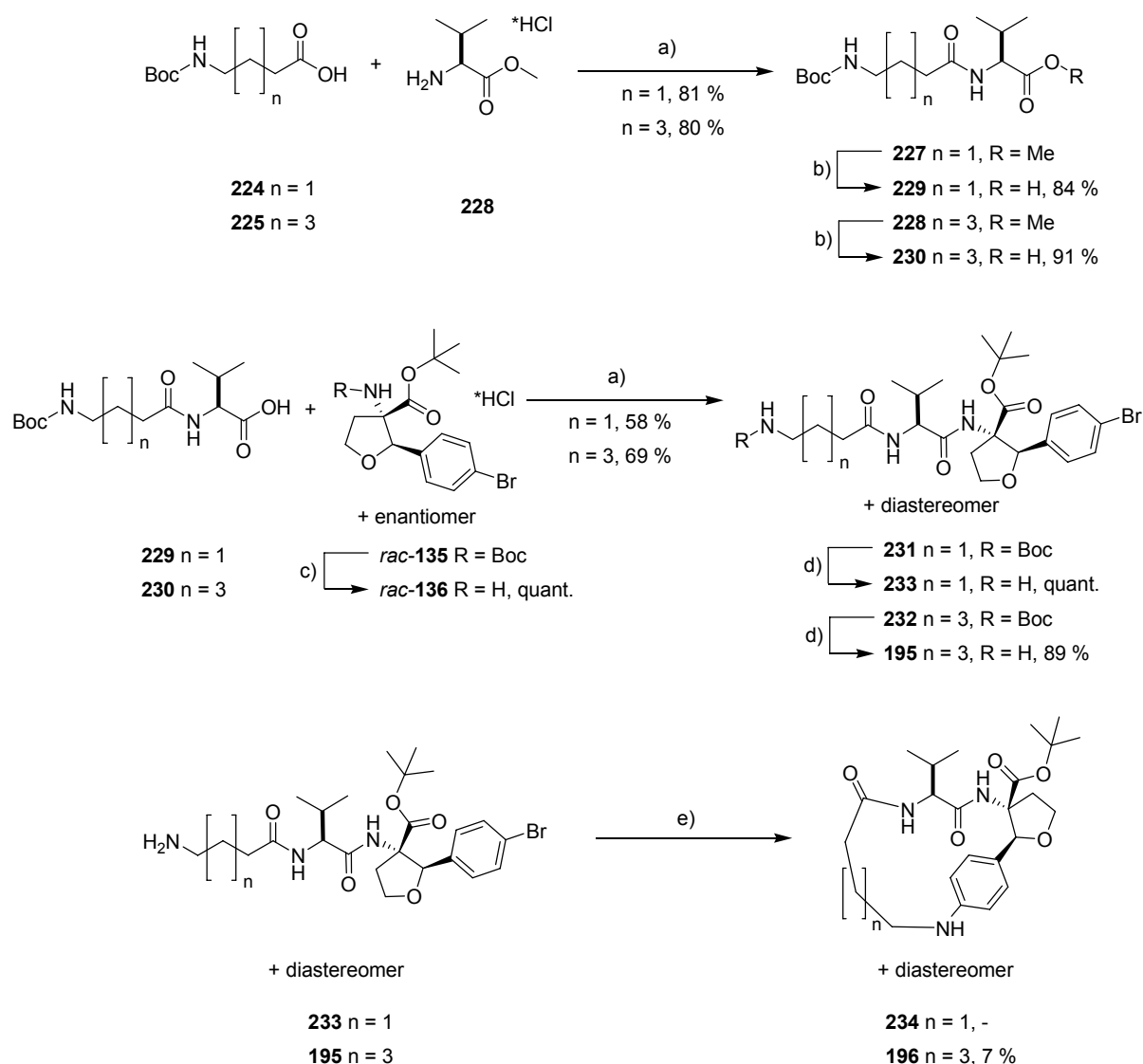

After ester saponification using LiOH as base, the resulting dipeptide acids **229** and **230** were coupled to the Boc-protected TAA *rac*-**136**. Both tripeptides were obtained in good yields, but as a 1:1 mixture of diastereomers because the racemic amine *rac*-**136** was used. A chromatographic separation of the diastereomers was not possible after this step of the synthesis. The following Boc-deprotection of both compounds **231** and **234** was accomplished by the use of 8 % TFA solution in dry DCM. Higher concentrations of TFA or the use of HCl saturated diethyl ether lead to a partial cleavage of the tert. butyl ester moiety. The obtained diastereomeric mixtures of the amines **195** and **233** were used in the CuI catalyzed cyclisation reaction (10 mol% CuI, 20 mol% *L*-proline, K₂CO₃, DMSO) after deprotonation by a strongly basic ion exchange resin. The concentration of the starting materials in the reaction mixture was lowered for the cyclisation reactions by a factor of ten to prevent the deprotected precursors **195** and **233** from intermolecular polymerisation instead of the desired intramolecular cyclisation. The shorter amine **233** was found to be unreactive under the applied conditions which may be rationalized by the small ring size of 15 atoms and the resulting strained cyclic tripeptide. Compound **195** gave product **196** although only in 7 % yield.⁴

Besides the successful attempt to couple the *N*-terminus of the tripeptide **195** with the aryl halide sidechain, it was also tried to develop reactions to couple the *C*-terminus of a tripeptide or the side chain of a second amino acid to the side chain aryl halide of *rac*-**135** incorporated in the sequence. The reactions were conducted using the previously prepared dipeptides **181** and **183**. To allow a coupling of the *C*-terminus with the side chain aryl halide of **181** and **183**, two different mono-Cbz-protected amines **50** and **235** were coupled to the dipeptides in good yields. For the cyclisation reaction between two side chains, the protected lysine **240** was coupled to the diastereomers **181** and **183** in good yields.

Problems were encountered during the deprotection of the Cbz-group. Under the conditions normally used to cleave this protecting group, meaning the use of 10 % Pd on activated charcoal²⁴⁸ under an atmosphere of 10 bar hydrogen, no cleavage was observed. When using higher pressures and a longer reaction time of up to three days we observed a decomposition of the starting material. Further cleavage experiments were undertaken in the scope of the research internship at the SIOC, Shanghai. With the Pd on activated charcoal and the hydrogenation equipment used at the SIOC to cleave Cbz-groups, it was possible to quantitatively cleave the protecting group in 4 hours but unfortunately the aryl halide was replaced by a hydrogen atom. It is known that aromatic

⁴ Due to the low yield only spectroscopic analysis of the product **198** was possible. An analysis of the structural properties could not be performed.

systems can be dehalogenated by the use of Pd as catalyst and hydrogen. On the other hand, several examples are known in literature where aryl bromides have proven to be stable to the use of Pd and hydrogen at least for several hours.²⁴⁹ Astonishingly, under the conditions applied the dehalogenation took place in less than 30 minutes while the Cbz-deprotection needed about 4 hours to come to completion. Hence, it was not possible to form the desired precursors, at least not with the combination of Pd and hydrogen. Looking for alternatives, it was attempted to cleave the Cbz group by use of HBr in glacial acetic acid.^{248, 250} Obviously these conditions also cleave the Boc-protecting group, but we expected the *N*-terminus of the precursors to be less reactive in the cyclisation reaction when compared to the *C*-terminal amine because of the sterically demanding environment of the *N*-terminus. Unfortunately, HBr in glacial acetic acid gave a mixture containing a variety of decomposition products. Due to the high polarity caused by two free amine groups a purification was not successful.

Scheme 28: Preparation of the precursors for the Cu(I) catalyzed cyclisation via the *C*-terminus: a) DIPEA, HATU, HOAt, dry DMF, 24h, rt.

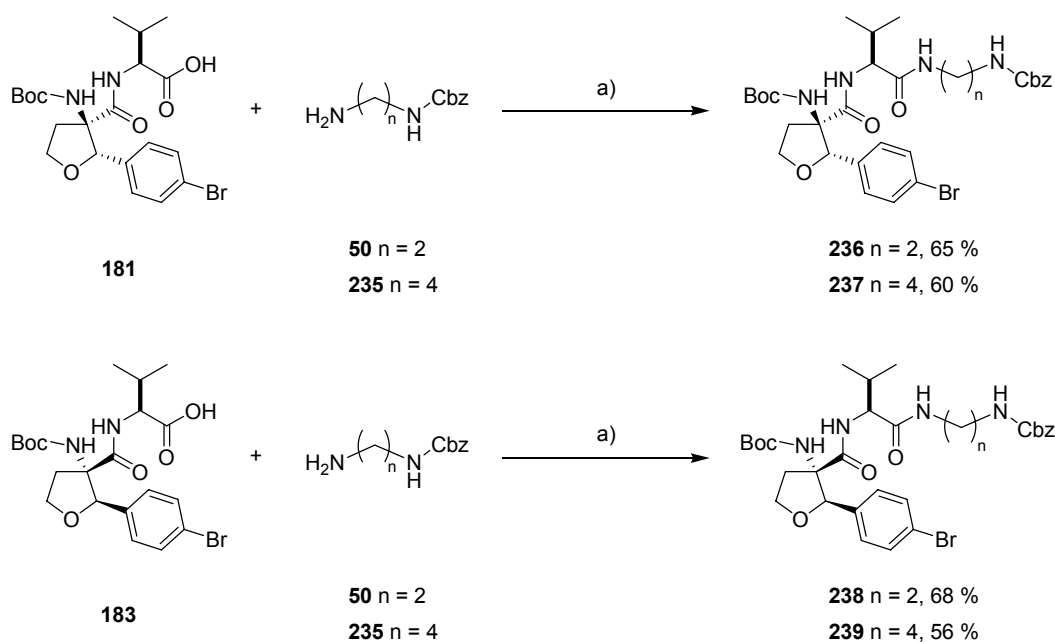

Scheme 29: Preparation of the precursors for the Cu(I) catalyzed cyclisation via the C-terminus: a) DIPEA, HATU, HOAt, dry DMF, 24h, rt.

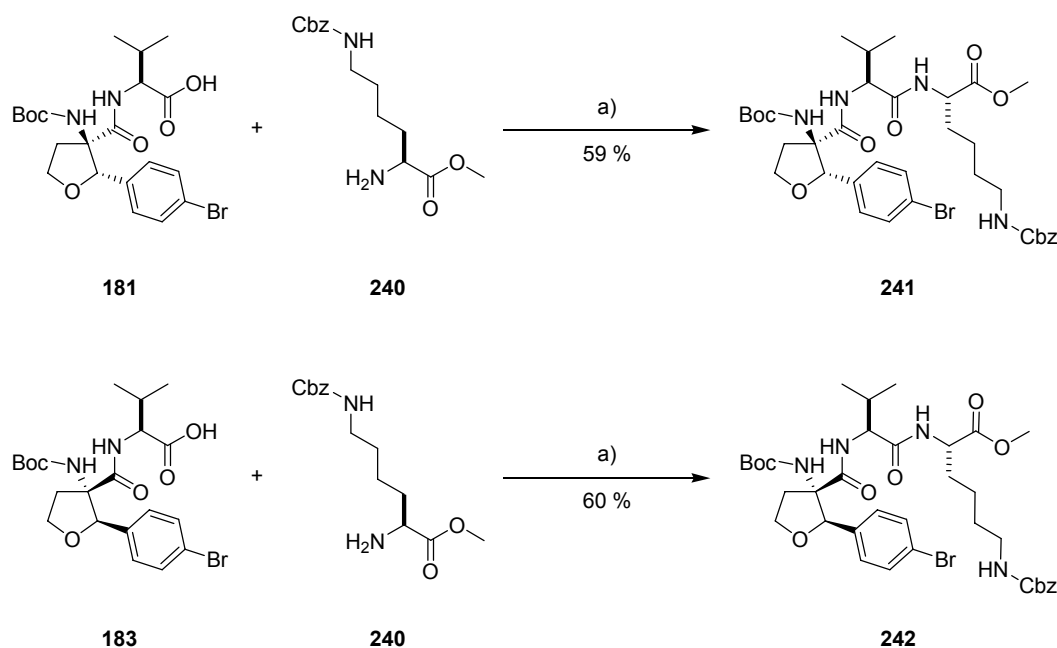

Because of the low yields obtained for the cyclisation reaction of compound **195** further attempts towards the synthesis of C-terminal side chain and side chain-side chain cyclized peptide mimetics were not performed.

4.2.3. Synthesis of Cyclic Tripeptide Mimics via C-O Arylation

The synthesis of cyclic peptides through a C-O arylation reaction was tested by the formation of a 15-membered ring system shown in Scheme 30. The structure was derived from a cyclic tripeptide mimic consisting of Phe, Ile and 3-bromopropan-1-amine. Fairlie *et al.* used this macrocycle to substitute the Phe-Ile-Val motif in the peptide Ac-Leu-Val-Phe-CHOHCH₂-{Phe-Ile-Val}-NH₂, which is a known inhibitor of HIV-1 protease derived from a substrate sequence. The substitution of the natural by the unnatural cyclic group resulted in an enhanced inhibitory activity.^{223, 251} Our goal was to synthesize a similar tripeptide macrocycle by the use of the unnatural amino acid *rac*-**138** instead of Phe leading to an even higher conformational constraint and to a more rigid secondary structure.

Scheme 30: Reaction sequence scheme leading to the macrocycles **198** and **252**: a) DIPEA, TBTU, HOAt, dry DMF, 24h, rt; b) LiOH, water/THF, 24h, rt; c) CH₃COOH, 1M TBAF in THF, MeCN, 12h, 0 °C - rt; d) Pd(OAc)₂, dicyclohexyl(2',4',6'-triisopropylbiphenyl-2-yl)phosphine, CsCO₃, toluene, 24 h, 80 °C.

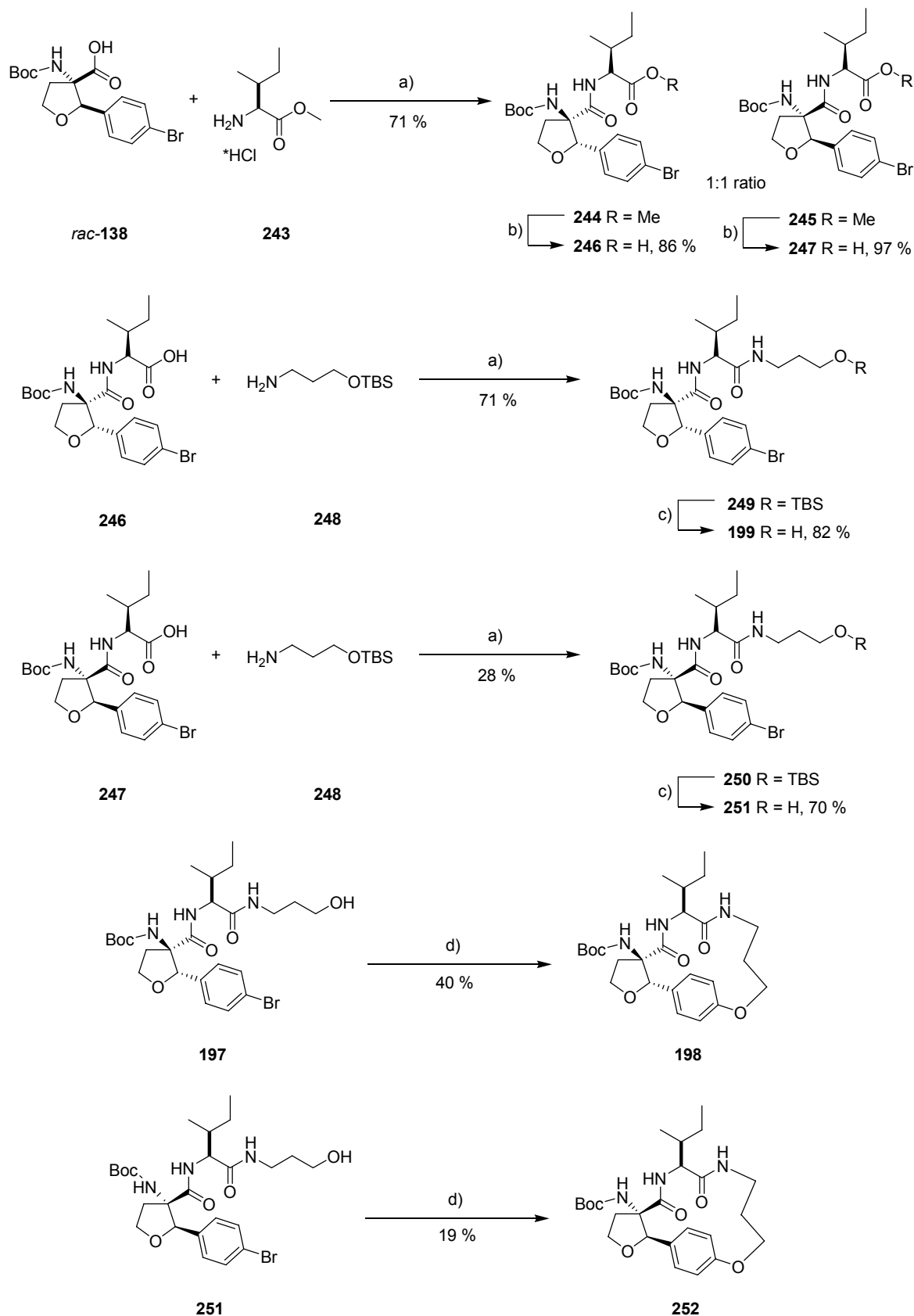

To form the acyclic precursors for the C-O arylation reaction, Boc-TAA-OH *rac*-**138** was coupled to *L*-isoleucine methyl ester hydrochloride **243** using EDC and HOBT as coupling reagents. Due to the racemic amino acid *rac*-**138**, two diastereomers **244** and **245** were formed, which could be easily separated by column chromatography. Crystals were obtained of compound **244** and an X-ray analysis was performed which revealed the absolute configuration (see Figure 94). The subsequent reaction steps were carried out separately with both diastereomers leading to two stereochemically different macrocycles with different secondary structures. After ester saponification the resulting free acids **246** and **247** were coupled with 3-(tert-butyldimethylsilyloxy)propan-1-amine **248** using TBTU and HOAt as coupling reagents. The protected precursors **249** and **250** were formed in good yields. After deprotection of the TBS-group they were used in the metal-catalyzed cyclisation reaction. As catalytic system, Pd(OAc)₂ with dicyclohexyl(2',4',6'-triisopropylbiphenyl-2-yl)phosphine as ligand and CsCO₃ as base were chosen. The reaction was conducted under an atmosphere of nitrogen at 80 °C in dry toluene as solvent. These reaction conditions were adopted from literature by changing the ligand to the dicyclohexyl(2',4',6'-triisopropylbiphenyl-2-yl)phosphine.^{230b, c} The use of a bulky ligand is important to prevent a β-hydride elimination in the temporarily formed oxidative addition. Another crucial reaction parameter is the concentration of the starting materials: When the reaction mixture was diluted the yield dropped drastically, while high concentrations resulted in the formation of cyclic dimers instead of the intramolecular ring closing reaction. The best results were obtained when 40 ml of toluene per mmol of starting material (**197** or **251**) were used, which corresponds to a concentration of c = 25 mmol/L. These reaction conditions yield 40 % for compound **198** and about 19 % of its diastereomer **252**.⁵

⁵ Both cyclic compounds **198** and **252** and their acyclic precursors **197** and **251** were tested in the Group of Prof. W. Diederich from the Philipps-University Marburg for their activity as HIV 1 protease inhibitors but were all found to be inactive.

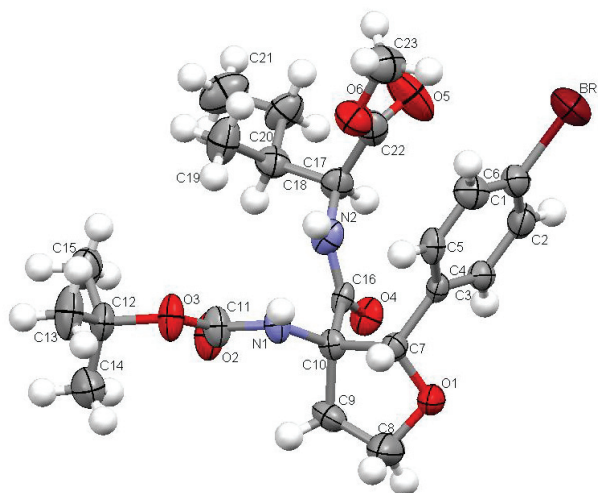

Figure 94: X-ray structure of compound **244**.

4.3. Conclusion

The CuI-catalyzed N-arylation of *rac*-**135** proceeds in moderate to good yields with a variety of amines allowing to introduce aliphatic aldehydes and different functional group containing amines into the side chain of the protected TAA *rac*-**135**. An intramolecular Cu(I)-catalyzed N-arylation reaction was used for the synthesis of the 17-membered macrocycle **196**, but the obtained yield was low. Pd(0)-catalyzed O-arylations gave higher yields for the macrocyclization of non-natural tripeptides containing TAA *rac*-**135**: The 15-membered macrocycle **198** was obtained in 40% isolated yield using Pd(OAc)₂ and a sterically demanding ligand. The examples illustrate that copper(I)-catalyzed N-arylations and palladium(0)-catalyzed O-arylations give access to side chain modified derivatives of the unnatural amino acid *rac*-**135** and macrocyclic peptidomimetics.

4.4. Experimental Part

X-ray data collections were performed using an Oxford Gemini Ultra diffractometer. The microwave irradiation experiments were conducted in a CEM Discover S-class laboratory microwave apparatus. IR spectra were recorded on a Bio-Rad FT-IR FTS 155 and a Bio-Rad FTS 2000 MX FT-IR using a Specac Golden Gate Mk II ATR accessory where stated. NMR spectrometers used were: Bruker Avance 600 (^1H : 600.1 MHz, ^{13}C : 150.1 MHz, T = 300 K), Bruker Avance 400 (^1H : 400.1 MHz, ^{13}C : 100.6 MHz, T = 300 K) and Bruker Avance 300 (^1H : 300.1 MHz, ^{13}C : 75.5 MHz, T = 300 K). The chemical shifts are reported in δ [ppm] relative to external standards (solvent residual peak). The spectra were analyzed by first order, the coupling constants are given in Hertz [Hz]. Characterization of the signals: s = singlet, d = doublet, t = triplet, q = quartet, m = multiplet, bs = broad singlet, psq = pseudo quintet, dd = double doublet, dt = double triplet, ddd = double double doublet. Integration is determined as the relative number of atoms. Assignment of signals in ^{13}C -spectra was determined with DEPT-technique (pulse angle: 135°) and given as (+) for CH_3 or CH, (-) for CH_2 and (C_{quat}) for quaternary C. Error of reported values: chemical shift: 0.01 ppm for ^1H -NMR, 0.1 ppm for ^{13}C -NMR and 0.1 Hz for coupling constants. The solvent used is reported for each spectrum. Mass spectra were recorded on Varian CH-5 (EI), Finnigan MAT 95 (CI; FAB and FD) and Finnigan MAT TSQ 7000 (ESI). Xenon served as the ionization gas for FAB. Melting Points were determined on a Büchi SMP-20 or Stanford Research System OpitMelt melting point apparatus and are uncorrected. Elemental analyses were carried out by the Center for Chemical Analysis of the Faculty of Natural Sciences of the University Regensburg.

All reagents and solvents used were of analytical grade purchased from commercial sources and were used without further purification. Unless otherwise stated, purification and drying of the solvents used was done according to accepted general procedures.²³⁹ CuI was washed with THF using a Soxhlet extractor before use to ensure a satisfactory catalytic activity. All reactions were performed under an inert atmosphere of N_2 or Ar using standard Schlenk techniques if not otherwise stated. TLC analyses were performed on silica gel 60 F-254 with a 0.2 mm layer thickness. Detection was via UV light at 254 nm / 366 nm or through discoloration with ninhydrin in EtOH. For preparative column-chromatography, Merck Geduran SI 60 (70-230 mesh) and Macherey-Nagel GmbH & Co. KG 60M (230–400 mesh) silica gels were used. For chromatography commercially available solvents of standard quality were used without further purification.

The following compounds were synthesized according to literature known procedures: Boc-TAA-OtBu *rac*-**135** and Boc-TAA-OH *rac*-**138**,²¹⁸ 4-(tert-butoxycarbonylamino)-

butanoic acid **224**,²⁵² 6-(tert-butoxycarbonylamino)hexanoic acid **225**,²⁵³ 3-(tert-butyl-dimethylsilyloxy)propan-1-amine **248**²⁵⁴ and benzyl 4-aminobutylcarbamate **235**.²⁵⁵

General Procedure for the CuI-catalyzed reactions (GP 2)

An oven-dried Schlenk tube equipped with a Teflon septum was charged with a magnetic stir bar. The tube was evacuated and backfilled with argon three times. The compound *rac*-**135** (1 eq.), the inorganic base K₂CO₃ or K₃PO₄ (2 eq.), CuI (10 - 30 mol%), the appropriate amino acid **A** or **B** (20 – 60 mol%) and the amine (1.5 eq.) if solid were added. The tube was again evacuated and backfilled with argon (this procedure was repeated three times). Under a counter flow of argon the amine (if liquid, 1.5 eq.) and the solvent DMSO (1 ml/mmol of compound *rac*-**135**, dry) were added via syringe. The tube was sealed and heated under stirring at the indicated temperature (50 – 100 °C) for 48 hours. After completion of the reaction the mixture was allowed to cool to room temperature and was then quenched with water (2 ml/mmol *rac*-**135**). The mixture was extracted three times with ethyl acetate (5 ml/mmol *rac*-**135**, each), the combined organic layers were dried over MgSO₄, filtered and the solvent was evaporated under reduced pressure to give the crude product. Purification was accomplished by the use of column chromatography with the solvent mixture indicated for each reaction.

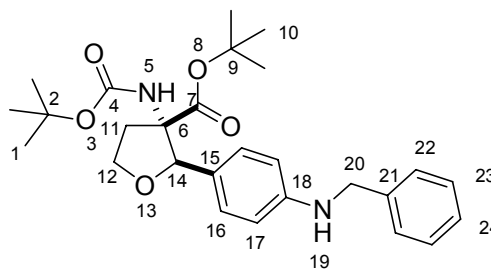

rac-tert-Butyl 2-(4-(benzylamino)phenyl)-3-(tert-butoxycarbonylamino)-tetrahydrofuran-3-carboxylate (*rac*-210):

The synthesis followed **GP2** using *rac*-tert-butyl 2-(4-bromophenyl)-3-(tert-butoxycarbonylamino)-tetrahydrofuran-3-carboxylate *rac*-135 (200 mg, 0.45 mmol), benzylamine **199** (74 μ l, 0.68 mmol), K_2CO_3 (125 mg, 0.90 mmol), CuI (9 mg, 0.05 mmol), *L*-proline (10 mg, 0.10 mmol) and 0.45 ml DMSO. The crude product was purified using a 8:2 mixture of PE and EtOAc ($R_f = 0.08$) giving the product as a colorless solid in 70 % yield. (148 mg, 0.32 mmol)

MP 148 °C. – 1H -NMR (300 MHz, $CDCl_3$) $\delta = 1.06$ (s, 9 H, 10), 1.33 (s, 9 H, 1), 2.45 (bs, 1 H, 11), 2.62–2.78 (m, 1 H, 11), 3.96–4.10 (m, 2 H, 12 + 19), 4.16–4.28 (m, 3 H, 12 + 20), 4.72 (s, 1 H, 14), 5.33 (bs, 1 H, 5), 6.46 (d, $^3J_{H,H} = 8.5$, 2 H, 17), 7.01 (d, $^3J_{H,H} = 8.5$, 2 H, 16), 7.12–7.30 (m, 5 H, 22–24). – ^{13}C -NMR (75 MHz, $CDCl_3$): $\delta = 27.5$ (+, 3 C, 1), 28.4 (+, 3 C, 10), 35.6 (–, 1 C, 11), 48.1 (–, 1 C, 20), 67.6 (–, 1 C, 12), 69.8 (C_{quat} , 1 C, 6), 79.8 (C_{quat} , 1 C, 2), 81.7 (C_{quat} , 1 C, 9), 86.6 (+, 1 C, 14), 112.4 (+, 2 C, 17), 126.0 (C_{quat} , 1 C, 15), 127.1 (+, 1 C, 24), 127.3 (+, 2 C, 22/23), 127.6 (C_{quat} , 1 C, 22/23), 128.6 (+, 2 C, 16), 139.4 (C_{quat} , 1 C, 21), 148.0 (C_{quat} , 1 C, 18), 154.7 (C_{quat} , 1 C, 4), 170.0 (C_{quat} , 1 C, 7). – **MS** (ESI, MeOH): m/z (%) = 469.2 (12) [MH^+], 491.2 (100) [MNa^+]. – **HR-MS** (PI-EIMS, MeOH): [M^+] calcd. for $C_{27}H_{36}N_2O_5$ 468.2624; found 468.2621. – **IR** (neat) [cm^{-1}]: $\tilde{\nu} = 3370, 2979, 2931, 2869, 2361, 1708, 1617, 1505, 1367, 1274, 1257, 1166, 1058, 965, 884, 832$. – **MF** $C_{27}H_{36}N_2O_5$. – **MW** 468.59.

X-Ray structure and crystal data of *rac*-**210**:

Monoclinic; space group: P 21/n; cell dimensions: $a = 12.8379(5) \text{ \AA}$, $\alpha = 90^\circ$, $b = 5.8585(2) \text{ \AA}$, $\beta = 90.048(4)^\circ$, $c = 33.9533(13) \text{ \AA}$, $\gamma = 90^\circ$; $V = 2553.66(16) \text{ \AA}^3$; $Z = 4$, $D_x = 1.219 \text{ Mg/m}^3$; $\mu = 0.676 \text{ mm}^{-1}$; $F(000) = 1008$. Data collection: $T = 123 \text{ K}$; graphite monochromator. A colorless crystal with dimensions of $0.490 \times 0.060 \times 0.030 \text{ mm}$ was used to measure 6964 reflections (4049 unique reflections, $R_{\text{int}} = 0.0388$) from 3.68° to 66.79° on a Oxford Diffraction Gemini Ultra diffractometer with the omega-scan method. Structure refinement: The F^2 value was refined using the full-matrix least squares refinement method, with a goodness-of-fit of 1.100 for all reflections and 1006 parameters.

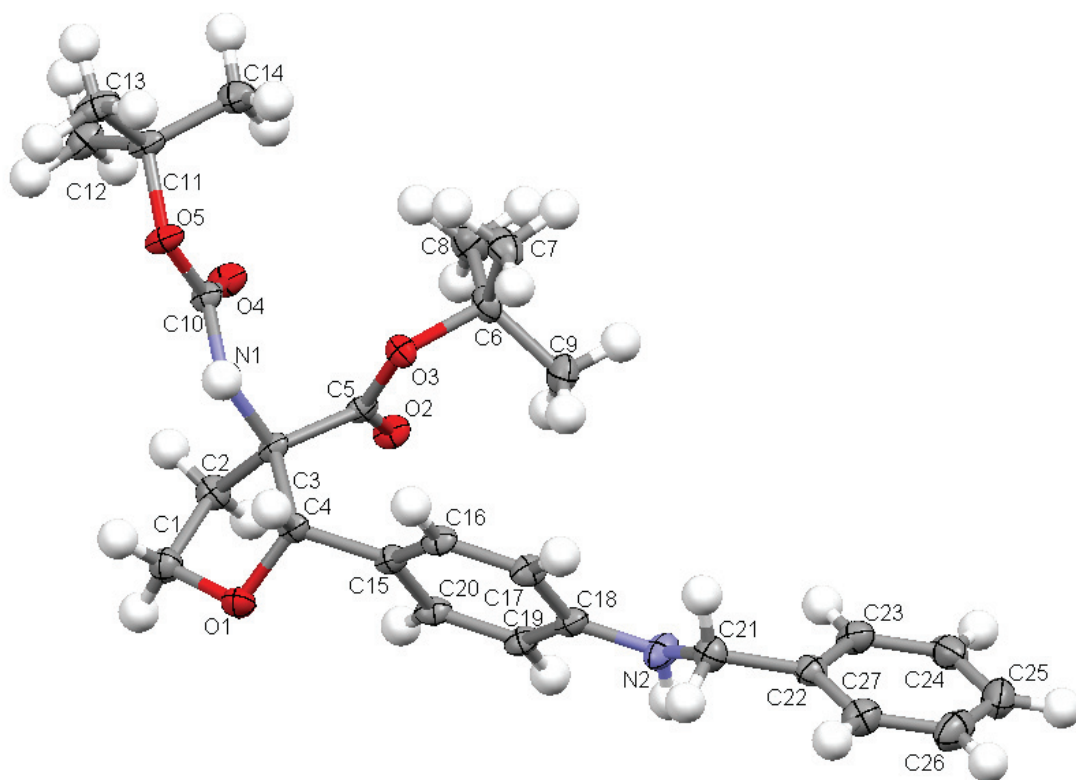

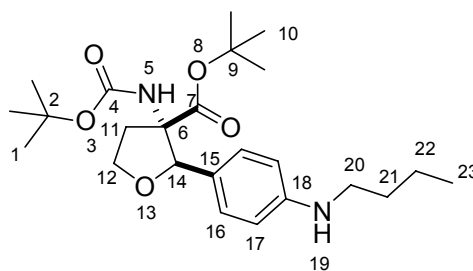

rac-tert-Butyl 3-(tert-butoxycarbonylamino)-2-(4-(butylamino)phenyl)-tetrahydrofuran-3-carboxylate (rac-211):

The synthesis followed **GP2** using *rac*-tert-butyl 2-(4-bromophenyl)-3-(tert-butoxycarbonylamino)-tetrahydrofuran-3-carboxylate *rac*-**135** (250 mg, 0.57 mmol), butylamine **200** (84 μ l, 0.85 mmol), K_3PO_4 (240 mg, 1.13 mmol), CuI (11 mg, 0.06 mmol), *L*-proline (13 mg, 0.11 mmol) and 0.57 ml DMSO. The crude product was purified using a 9:1 mixture of PE and EtOAc (R_f = 0.19) giving the product as a colorless solid in 65 % yield. (161 mg, 0.37 mmol)

MP 149 °C. – **1H -NMR** (300 MHz, $CDCl_3$) δ = 0.93 (t, $^3J_{H,H}$ = 7.3, 3 H, 23), 1.16 (s, 9 H, 10), 1.33–1.49 (m, 11 H, 1 + 22), 1.63–1.51 (m, 2 H, 21), 2.53 (bs, 1 H, 11), 2.88–2.71 (m, 1 H, 11), 3.08 (t, $^3J_{H,H}$ = 8.2, 2 H, 20), 3.60 (s, 1 H, 19), 4.10 (q, $^3J_{H,H}$ = 8.1, 1 H, 12), 4.29 (td, $^3J_{H,H}$ = 3.7, $^3J_{H,H}$ = 8.3, 1 H, 12), 4.80 (s, 1 H, 5), 5.41 (s, 1 H, 14), 6.52 (d, $^3J_{H,H}$ = 8.5, 2 H, 17), 7.09 (d, $^3J_{H,H}$ = 8.5, 2 H, 18). – **^{13}C -NMR** (75 MHz, $CDCl_3$): δ = 13.9 (+, 1 C, 23), 20.2 (-, 1 C, 22), 27.5 (+, 3 C, 1), 28.4 (+, 3 C, 10), 31.5 (-, 1 C, 21), 35.6 (-, 1 C, 11), 43.7 (-, 1 C, 20), 67.5 (-, 1 C, 12), 69.8 (C_{quat} , 1 C, 6), 79.8 (C_{quat} , 1 C, 2), 81.7 (C_{quat} , 1 C, 9), 86.7 (+, 1 C, 14), 112.2 (+, 2 C, 17), 125.5 (C_{quat} , 1 C, 15), 127.5 (+, 2 C, 16), 148.5 (C_{quat} , 1 C, 18), 154.7 (C_{quat} , 1 C, 4), 170.1 (C_{quat} , 1 C, 7). – **MS** (ESI, MeOH): m/z (%) = 457.2 (100) [MNa^+], 473.1 (34) [MK^+]. – **HR-MS** (FAB, MeOH/glycerol): [M^+] calcd. for $C_{24}H_{38}N_2O_5$ 434.2781; found 434.2775. – **IR** (neat) [cm^{-1}]: $\tilde{\nu}$ = 3371, 2976, 2869, 1708, 1617, 1505, 1367, 1274, 1180, 1059, 965, 833. – **MF** $C_{24}H_{38}N_2O_5$. – **MW** 434.57.

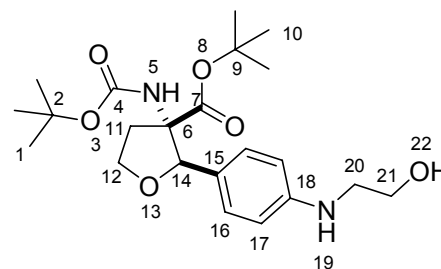

rac-tert-Butyl 3-(tert-butoxycarbonylamino)-2-(4-(2-hydroxyethylamino)phenyl)-tetrahydrofuran-3-carboxylate (*rac*-**212**):

The synthesis followed **GP2** using *rac*-tert-butyl 2-(4-bromophenyl)-3-(tert-butoxycarbonylamino)-tetrahydrofuran-3-carboxylate *rac*-**135** (250 mg, 0.57 mmol), 2-aminoethanol **201** (52 μ l, 0.85 mmol), K_2CO_3 (156 mg, 1.13 mmol), CuI (11 mg, 0.06 mmol), *L*-proline (13 mg, 0.11 mmol) and 0.57 ml DMSO. The crude product was purified using an gradient of DCM and methanol (DCM:MeOH 99.5:0.5 \rightarrow 99:1, R_f (99:1) = 0.16) giving the product as a colorless solid in 42 % yield. (100 mg, 0.24 mmol)

MP 166-167 $^{\circ}C$. – **1H -NMR** (300 MHz, $CDCl_3$) δ = 1.16 (s, 9 H, 10), 1.47 (s, 9 H, 1), 2.53 (bs, 1 H, 11), 2.70–2.85 (m, 1 H, 11), 3.23 (bs, 2 H, 20), 3.77 (t, $^3J_{H,H}$ = 5.1, 2 H, 21), 4.10 (q, $^3J_{H,H}$ = 8.0, 1 H, 12), 4.29 (dt, $^3J_{H,H}$ = 3.6, $^3J_{H,H}$ = 8.2, 1 H, 12), 4.80 (bs, 1 H, 14), 5.37 (bs, 1 H, 5), 6.55 (d, $^3J_{H,H}$ = 8.4, 2 H, 17), 7.10 (d, $^3J_{H,H}$ = 8.4, 2 H, 16). – **^{13}C -NMR** (125 MHz, $CDCl_3$): δ = 27.5 (+, 3 C, 1), 28.3 (+, 3 C, 10), 35.6 (-, 1 C, 11), 46.1 (-, 1 C, 20), 61.0 (-, 1 C, 21), 67.6 (-, 1 C, 12), 69.8 (C_{quat} , 1 C, 6), 79.9 (C_{quat} , 1 C, 2), 81.9 (C_{quat} , 1 C, 9), 86.5 (+, 1 C, 14), 112.8 (+, 2 C, 17), 126.3 (C_{quat} , 1 C, 15), 127.6 (+, 2 C, 16), 148.2 (C_{quat} , 1 C, 18), 154.8 (C_{quat} , 1 C, 4), 170.0 (C_{quat} , 1 C, 7). – **MS** (ESI, MeOH): m/z (%) = 445.1 (100) [MNa^+], 461.2 (22) [MK^+]. – **HR-MS** (PI-EIMS, MeOH): [M^+] calcd. for $C_{22}H_{34}N_2O_6$ 422.2417; found 422.2427. – **IR** (neat) [cm^{-1}]: $\tilde{\nu}$ = 3363, 2975, 2936, 2868, 1707, 1615, 1510, 1368, 1274, 1255, 1171, 1039, 826. – **MF** $C_{22}H_{34}N_2O_6$. – **MW** 422.52.

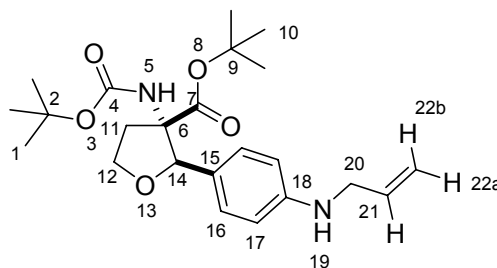

rac-tert-Butyl 2-(4-(allylamino)phenyl)-3-(tert-butoxycarbonylamino)-tetrahydrofuran-3-carboxylate (*rac*-**213**):

The synthesis followed **GP2** using *rac*-tert-butyl 2-(4-bromophenyl)-3-(tert-butoxycarbonylamino)-tetrahydrofuran-3-carboxylate **rac-135** (250 mg, 0.57 mmol), allylamine **202** (64 μ l, 0.85 mmol), K_2CO_3 (156 mg, 1.13 mmol), CuI (11 mg, 0.06 mmol), *L*-proline (13 mg, 0.11 mmol) and 0.57 ml DMSO. The crude product was purified using a 9:1 mixture of PE and EtOAc (R_f = 0.13) giving the product as a colorless solid in 54 % yield. (129 mg, 0.31 mmol)

MP 132-134 $^{\circ}C$. – **1H -NMR** (300 MHz, $CDCl_3$): δ = 1.15 (s, 9 H, 10), 1.47 (s, 9 H, 1), 2.53 (bs, 1 H, 11), 2.69-2.85 (m, 1 H 11), 3.75-3.94 (m, 3 H, 19 + 20), 4.11 (q, $^3J_{H,H}$ = 8.1, 1 H, 12), 4.29 (dt, $^3J_{H,H}$ = 8.3, $^3J_{H,H}$ = 3.7, 1 H, 12), 4.80 (s, 1 H, 14), 5.13 (dd, $^2J_{H,H}$ = 1.4, $^3J_{H,H}$ = 10.3, 1 H, 22a), 5.23 (dd, $^2J_{H,H}$ = 1.5, $^3J_{H,H}$ = 17.2, 1 H, 22b), 5.41 (s, 1 H, 5), 5.83-5.98 (m, 1 H, 21), 6.54 (d, $^3J_{H,H}$ = 8.6, 2 H, 17), 7.10 (d, $^3J_{H,H}$ = 8.4, 2 H, 16). – **^{13}C -NMR** (75 MHz, $CDCl_3$): δ = 27.5 (+, 3 C, 1), 28.4 (+, 3 C, 10), 35.6 (-, 1 C, 11), 46.4 (-, 2 C, 20), 67.6 (-, 1 C, 12), 69.8 (C_{quat} , 1 C, 6), 79.9 (C_{quat} , 1 C, 2), 81.8 (C_{quat} , 1 C, 9), 86.5 (+, 1 C, 14), 112.5 (+, 2 C, 17), 116.1 (-, 1 C, 22), 126.0 (C_{quat} , 1 C, 15), 127.5 (+, 2 C, 16), 135.3 (+, 1 C, 21), 148.0 (C_{quat} , 1 C, 18), 154.7 (C_{quat} , 1 C, 4), 170.1 (C_{quat} , 1 C, 7). – **MS** (ESI, MeOH): m/z (%) = 441.1 (100) [MNa^+], 457.0 (23) [MK^+]. – **HR-MS** (PI-EIMS, MeOH): [M^+] calcd. for $C_{23}H_{34}N_2O_5$ 418.2468; found 418.2457. – **IR** (neat) [cm^{-1}]: $\tilde{\nu}$ = 3413, 3355, 2983, 2931, 2884, 2357, 1707, 1614, 1510, 1368, 1270, 1179, 1067, 1044, 909, 824. – **MF** $C_{23}H_{34}N_2O_5$. – **MW** 418.53.

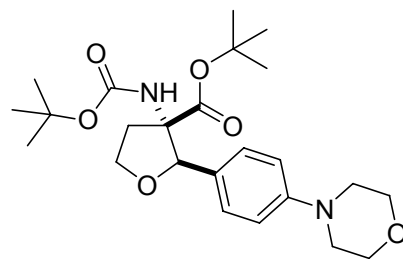

rac-tert-Butyl 3-(tert-butoxycarbonylamino)-2-(4-morpholinophenyl)-tetrahydrofuran-3-carboxylate (*rac*-215):

The synthesis followed **GP2** using *rac*-tert-butyl 2-(4-bromophenyl)-3-(tert-butoxycarbonylamino)-tetrahydrofuran-3-carboxylate *rac*-135 (250 mg, 0.57 mmol), morpholine **204** (74 μ l, 0.85 mmol), K_2CO_3 (156 mg, 1.13 mmol), CuI (11 mg, 0.06 mmol), *L*-proline (13 mg, 0.11 mmol) and 0.57 ml DMSO. The crude product was purified using a 9:1 mixture of PE and EtOAc (R_f = 0.13) giving the product as a colorless solid in 33 % yield. (90 mg, 0.19 mmol)

Literature known compound.²¹⁸

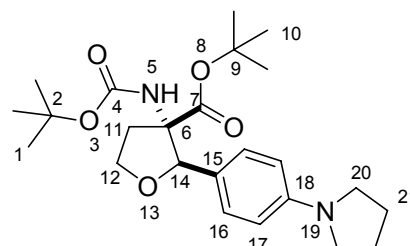

rac-tert-Butyl 2-(4-(allylamino)phenyl)-3-(tert-butoxycarbonylamino)-tetrahydrofuran-3-carboxylate (*rac*-216):

The synthesis followed **GP2** using *rac*-tert-butyl 2-(4-bromophenyl)-3-(tert-butoxycarbonylamino)-tetrahydrofuran-3-carboxylate *rac*-135 (250 mg, 0.57 mmol), pyrrolidine **205** (60 mg, 0.85 mmol), K_2CO_3 (156 mg, 1.13 mmol), CuI (11 mg, 0.06 mmol), *L*-proline (13 mg, 0.11 mmol) and 0.57 ml DMSO. The crude product was purified using a 9:1 mixture of PE and EtOAc (R_f = 0.25) giving the product as a colorless solid in 73 % yield. (179 mg, 0.41 mmol)

MP 108-110 °C. – **1H -NMR** (300 MHz, $CDCl_3$) δ = 1.18 (s, 9 H, 10), 1.47 (s, 9 H, 1), 1.94-2.01 (m, 2 H, 21), 2.54 (bs, 1 H, 11), 2.73–2.86 (m, 1 H, 11), 3.18-3.37 (m, 2 H, 20), 4.11 (q, $^3J_{H,H}$ = 8.0, 1 H, 12), 4.30 (dt, $^3J_{H,H}$ = 8.3, $^3J_{H,H}$ = 3.9, 1 H, 12), 4.81 (s, 1 H, 14), 5.40 (bs, 1 H, 5), 6.48 (d, $^3J_{H,H}$ = 8.5, 2 H, 17), 7.13 (d, $^3J_{H,H}$ = 8.6, 2 H, 16). – **^{13}C -NMR** (75 MHz, $CDCl_3$): δ = 25.3 (-, 2 C, 21), 27.6 (+, 3 C, 1), 28.3 (+, 3 C, 10), 35.4 (-, 1 C, 11), 47.7 (-, 2 C, 20), 67.4 (-, 1 C, 12), 69.8 (C_{quat} , 1 C, 6), 79.7 (C_{quat} , 1 C, 2), 81.7 (C_{quat} , 1 C, 9), 86.6 (+, 1 C, 14), 111.3 (+, 2 C, 17), 123.8 (C_{quat} , 1 C, 15), 127.4 (+, 2 C, 16), 147.9

(C_{quat}, 1 C, 18), 154.7 (C_{quat}, 1 C, 4), 170.0 (C_{quat}, 1 C, 7). – **MS** (ESI, MeOH): *m/z* (%) = 377.1 (13) [MH⁺ - C₄H₈], 433.1 (100) [MH⁺], 455.1 (19) [MNa⁺]. – **HR-MS** (PI-EIMS, MeOH): [M⁺] calcd. for C₂₄H₃₆N₂O₅ 432.2624; found 432.2629. – **IR** (neat) [cm⁻¹]: $\tilde{\nu}$ = 3371, 2971, 2853, 2168, 1707, 1613, 1511, 1369, 1278, 1253, 1160, 1045, 817. – **MF** C₂₄H₃₆N₂O₅. – **MW** 432.55.

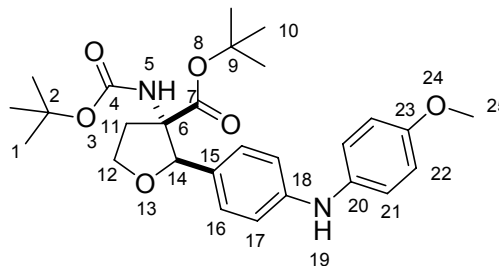

rac-tert-Butyl 3-(tert-butoxycarbonylamino)-2-(4-(4-methoxyphenylamino)phenyl)tetrahydrofuran-3-carboxylate (*rac*-**217**):

The synthesis followed **GP2** using *rac*-tert-butyl 2-(4-bromophenyl)-3-(tert-butoxycarbonylamino)-tetrahydrofuran-3-carboxylate *rac*-**135** (250 mg, 0.57 mmol), pyrrolidine **206** (104 mg, 0.85 mmol), K₂CO₃ (156 mg, 1.13 mmol), Cul (11 mg, 0.06 mmol), *L*-proline (13 mg, 0.11 mmol) and 0.57 ml DMSO. The crude product was purified using a 9:1 mixture of PE and EtOAc (*R_f* = 0.29) giving the product as a colorless solid in 73 % yield. (135 mg, 0.28 mmol)

MP 139 °C. – **¹H-NMR** (300 MHz, CDCl₃) δ = 1.18 (s, 9 H, 10), 1.47 (s, 9 H, 1), 2.56 (bs, 1 H, 11), 2.71–2.83 (m, 1 H, 11), 3.78 (s, 3 H, 25), 4.13 (q, ³J_{H,H} = 8.0, 1 H, 12), 4.30 (dt, ³J_{H,H} = 3.6, ³J_{H,H} = 8.2, 1 H, 12), 4.85 (bs, 1 H, 14), 5.47 (bs, 1 H, 5), 6.83 (d, ³J_{H,H} = 8.3, 4 H, 17 + 22), 7.01 (d, ³J_{H,H} = 8.8, 2 H, 16), 7.15 (d, ³J_{H,H} = 8.4, 2 H, 21). – **¹³C-NMR** (75 MHz, CDCl₃): δ = 27.5 (+, 3 C, 1), 28.4 (+, 3 C, 10), 35.6 (-, 1 C, 11), 55.5 (+, 1 C, 25), 67.6 (-, 1 C, 12), 69.8 (C_{quat}, 1 C, 6), 79.9 (C_{quat}, 1 C, 2), 81.9 (C_{quat}, 1 C, 9), 86.2 (+, 1 C, 14), 114.6 (+, 2 C, 17/22), 115.3 (+, 2 C, 17/22), 121.8 (+, 2 C, 21), 127.5 (+, 2 C, 16), 128.3 (C_{quat}, 1 C, 15), 135.8 (C_{quat}, 1 C, 20), 144.9 (C_{quat}, 1 C, 18), 154.6 (C_{quat}, 1 C, 4), 155.2 (C_{quat}, 1 C, 23), 170.1 (C_{quat}, 1 C, 7). – **MS** (ESI, MeOH): *m/z* (%) = 507.1 (100) [MNa⁺], 523.0 (11) [MK⁺]. – **HR-MS** (FAB, MeOH/glycerol): [M⁺] calcd. for C₂₇H₃₆N₂O₆ 484.2573; found 484.2567. – **IR** (neat) [cm⁻¹]: $\tilde{\nu}$ = 3364, 2980, 1710, 1616, 1502, 1368, 1250, 1163, 1037, 926. – **MF** C₂₇H₃₆N₂O₆. – **MW** 484.58.

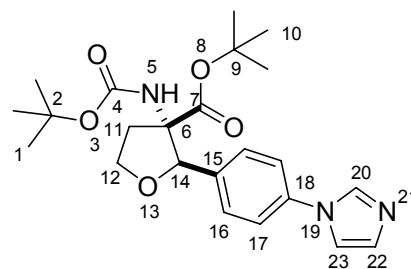

rac-tert-Butyl 2-(4-(1H-imidazol-1-yl)phenyl)-3-(tert-butoxycarbonylamino)-tetrahydrofuran-3-carboxylate (*rac*-**218**):

The synthesis followed **GP2** using *rac*-tert-butyl 2-(4-bromophenyl)-3-(tert-butoxycarbonylamino)-tetrahydrofuran-3-carboxylate *rac*-**135** (250 mg, 0.57 mmol), imidazole **207** (104 mg, 0.85 mmol), K₂CO₃ (156 mg, 1.13 mmol), CuI (11 mg, 0.06 mmol), *L*-proline (13 mg, 0.11 mmol) and 0.57 ml DMSO. The crude product was purified using a 8:2 mixture of PE and EtOAc (*R*_f = 0.18) giving the product as a colorless solid in 49 % yield. (119 mg, 0.28 mmol)

MP 110 °C. – **¹H-NMR** (300 MHz, CDCl₃): δ = δ = 1.05 (s, 9 H, 10), 1.42 (s, 9 H, 1), 2.42–2.77 (m, 2 H, 11), 4.14 (q, ³J_{H,H} = 8.1, 1 H, 12), 4.27 (dt, ³J_{H,H} = 4.0, ³J_{H,H} = 8.1, 1 H, 12), 5.06 (s, 1 H, 14), 5.96 (s, 1 H, NH), 7.12 (s, 1 H, 22), 7.19 (s, 1 H, 23), 7.27 (d, ³J_{H,H} = 8.8, 2 H, 17), 7.41 (d, ³J_{H,H} = 8.5, 2 H, 16), 7.77 (s, 1 H, 20). – **¹³C-NMR** (75 MHz, CDCl₃): δ = 27.4 (+, 3 C, 1), 28.4 (+, 3 C, 10), 35.9 (-, 1 C, 11), 67.9 (-, 1 C, 12), 69.9 (C_{quat}, 1 C, 6), 80.0 (C_{quat}, 1 C, 2), 82.3 (C_{quat}, 1 C, 9), 84.6 (+, 1 C, 14), 118.2 (+, 1 C, 23), 120.8 (+, 2 C, 17), 127.9 (+, 2 C, 16), 130.3 (+, 1 C, 22), 135.4 (+, 1 C, 20), 136.8 (C_{quat}, 1 C, 18), 137.4 (C_{quat}, 1 C, 15), 154.5 (C_{quat}, 1 C, 4), 169.9 (C_{quat}, 1 C, 7). – **MS** (ESI, MeOH): *m/z* (%) = 430.1 (100) [MH⁺], 452.1 (24) [MNa⁺]. – **HR-MS** (FAB, MeOH/glycerol): [MH⁺] calcd. for C₂₃H₃₂N₃O₆ 430.2342; found 430.2334. – **IR** (neat) [cm⁻¹]: $\tilde{\nu}$ = 3414, 3357, 2982, 2883, 1706, 1612, 1510, 1367, 1252, 1154, 1111, 1067, 910, 825. – **MF** C₂₄H₃₆N₂O₇. – **MW** 464.25.

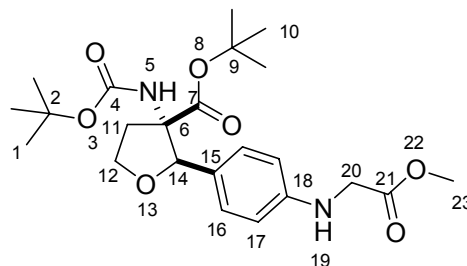

rac-tert-Butyl 3-(tert-butoxycarbonylamino)-2-(4-(2-methoxy-2-oxoethylamino)phenyl)-tetrahydrofuran-3-carboxylate (*rac*-219):

The synthesis followed **GP2** using *rac*-tert-butyl 2-(4-bromophenyl)-3-(tert-butoxycarbonylamino)-tetrahydrofuran-3-carboxylate *rac*-135 (200 mg, 0.45 mmol), H-Gly-OMe **208** (70 mg, 0.68 mmol), K₂CO₃ (125 mg, 0.90 mmol), CuI (9 mg, 0.05 mmol), *L*-proline (10 mg, 0.09 mmol) and 0.45 ml DMSO. The crude product was purified using a 7:3 mixture of PE and EtOAc (*R_f* = 0.21) giving the product as a colorless solid in 13 % yield. (27 mg, 0.06 mmol)

MP 100-102 °C. – ¹H-NMR (300 MHz, CDCl₃): δ = δ = 1.14 (s, 9 H, 10), 1.46 (s, 9 H, 1), 2.55 (bs, 1 H, 11), 2.76 (dt, ³J_{H,H} = 8.4, ³J_{H,H} = 12.9, 1 H 11), 2.85 (s, 3 H, 23), 4.11 (q, ³J_{H,H} = 7.2, 2 H, 20), 4.29 (dt, ³J_{H,H} = 8.2, ³J_{H,H} = 3.8, 2 H, 12), 4.83 (s, 1 H, 14), 5.42 (s, 1 H, NH), 6.54 (d, ³J_{H,H} = 8.5, 2 H, 17), 7.13 (d, ³J_{H,H} = 8.5, 2 H, 16). – ¹³C-NMR (75 MHz, CDCl₃): δ = 27.5 (+, 3 C, 1), 28.4 (+, 3 C, 10), 35.6 (-, 1 C, 11), 45.7 (-, 1 C, 20), 52.3 (+, 1 C, 23), 67.7 (-, 1 C, 12), 69.8 (C_{quat}, 1 C, 6), 80.0 (C_{quat}, 1 C, 2), 81.9 (C_{quat}, 1 C, 9), 86.3 (+, 1 C, 14), 112.5 (+, 2 C, 17), 126.9 (C_{quat}, 1 C, 15), 127.6 (+, 2 C, 16), 146.9 (C_{quat}, 1 C, 18), 154.7 (C_{quat}, 1 C, 4), 170.1 (C_{quat}, 1 C, 7), 171.6 (C_{quat}, 1 C, 21). – **MS** (ESI, DCM/MeOH + 10 mM NH₄OAc): *m/z* (%) = 451.0 (50) [MH⁺], 489.0 (100) [MK⁺]. – **HR-MS** (PI-LSIMS, DCM/NBA): [M⁺] calcd. for C₂₃H₃₄N₂O₇ 450.2366; found 450.2360. – **IR** (neat) [cm⁻¹]: $\tilde{\nu}$ = 3361, 2983, 2361, 2337, 1722, 1698, 1617, 1511, 1367, 1174, 1067, 1046, 997, 824. – **MF** C₂₄H₃₆N₂O₇. – **MW** 464.25.

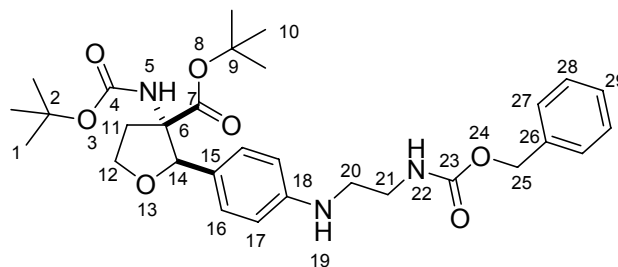

tert-Butyl 2-(4-(2-(benzyloxycarbonylamino)ethylamino)phenyl)-3-(tert-butoxycarbonylamino)-tetrahydrofuran-3-carboxylate (*rac*-**220**):

The synthesis followed **GP2** using *rac*-tert-butyl 2-(4-bromophenyl)-3-(tert-butoxycarbonylamino)-tetrahydrofuran-3-carboxylate *rac*-**135** (200 mg, 0.45 mmol), benzyl 2-aminoethylcarbamate **209** (132 mg, 0.68 mmol), K₂CO₃ (125 mg, 0.90 mmol), CuI (9 mg, 0.05 mmol), *L*-proline (10 mg, 0.09 mmol) and 0.45 ml DMSO. The crude product was purified using a 7:3 mixture of PE and EtOAc (*R*_f = 0.18) giving the product as a colorless solid in 23 % yield. (58 mg, 0.11 mmol)

MP 133 °C. – **¹H-NMR** (300 MHz, CDCl₃): δ = δ = 1.14 (s, 9 H, 10), 1.46 (s, 9 H, 1), 2.53 (bs, 1 H, 11), 2.77 (dt, ³J_{H,H} = 8.5, ²J_{H,H} = 12.9, 1 H, 11), 3.14-3.43 (m, 4 H, 20 + 21), 4.01-4.09 (m, 1 H, 12), 4.28 (dt, ³J_{H,H} = 8.3, ³J_{H,H} = 3.8, 1 H, 12), 5.07 (s, 1 H, 14), 5.09 (s, 2 H, 25), 5.44 (s, 1 H, NH), 6.49 (s, 1 H, NH), 6.52 (s, 1 H, NH), 7.08 (d, ³J_{H,H} = 8.2, 2 H, 17), 7.27-7.41 (m, 7 H, 18 + 27 - 29). – **¹³C-NMR** (75 MHz, CDCl₃): δ = 27.6 (+, 3 C, 1), 28.5 (+, 3 C, 10), 40.5 (-, 1 C, CH₂), 41.3 (-, 1 C, CH₂), 44.2 (-, 1 C, CH₂), 67.0 (-, 1 C, CH₂), 67.7 (-, 1 C, CH₂), 69.9 (C_{quat}, 1 C, 6), 80.0 (C_{quat}, 1 C, 2), 81.9 (C_{quat}, 1 C, 9), 86.5 (+, 1 C, 14), 112.4 (+, 2 C, 17), 127.7 (+, 2 C, 16), 128.2 (C_{quat}, 1 C, 27/28), 128.3 (+, 1 C, 29), 128.6 (+, 2 C, 27/28), 136.4 (C_{quat}, 1 C, 26), 147.8 (C_{quat}, 1 C, 18), 154.8 (C_{quat}, 1 C, 4), 156.9 (C_{quat}, 1 C, 23), 170.1 (C_{quat}, 1 C, 7). – **MS** (ES, DCM/MeOH + 10 mmol/l NH₄OAc): 556.1 (100) [MH⁺], 1111.7 (19) [2M + H⁺] – **HR-MS** (PI-EIMS, MeOH): [M⁺] calcd. for C₃₀H₄₁N₃O₇ 555.2945; found 555.2933. – **MF** C₂₄H₃₆N₂O₇. – **MW** 464.25.

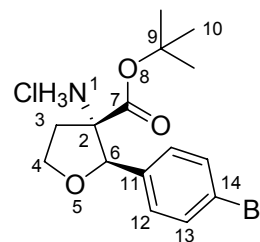

rac-tert-Butyl 3-amino-2-(4-bromophenyl)-tetrahydrofuran-3-carboxylate · HCl (*rac*-136):

Compound *rac*-135 (1.34 mg, 5.27 mmol) was dissolved in 17 ml of ether (15 ml/mmol) and cooled to 0 °C in an ice bath. To the solution 8 ml of HCl saturated ether (7 ml/mmol) were added. The mixture was allowed to warm to room temperature and stirred over night. The solvent was evaporated under reduced pressure to give the product as colorless hygroscopic solid in quantitative yield. No further purification was necessary. (420 mg, 1.11 mmol)

MP > 180 °C. – **¹H-NMR** (300 MHz, MeOH-*d*₄): δ = 1.16 (s, 9 H, 10), 2.30 (ddd, ³J_{H,H} = 3.6, ³J_{H,H} = 6.9, ²J_{H,H} = 13.7, 1 H, 3), 2.86 (t, ³J_{H,H} = 6.9, 1 H, 3), 4.15 (dt, ³J_{H,H} = 6.8, ³J_{H,H} = 8.9, 1 H, 4), 4.46 (dt, ³J_{H,H} = 3.6, ³J_{H,H} = 8.6, 1 H, 4), 4.98 (s, 1 H, 6), 7.35 (d, ³J_{H,H} = 8.2, 2 H, 12), 7.56 (d, ³J_{H,H} = 8.5, 2 H, 13). – **¹³C-NMR** (75 MHz, MeOH-*d*₄): δ = 27.6 (+, 3 C, 10), 37.2 (-, 1 C, 3), 68.6 (-, 1 C, 4), 70.1 (C_{quat}, 1 C, 2), 86.1 (C_{quat}, 1 C, 9), 87.7 (+, 1 C, 6), 123.8 (C_{quat}, 1 C, 14), 129.9 (+, 2 C, 12), 132.6 (+, 2 C, 13), 136.6 (C_{quat}, 1 C, 11), 168.1 (C_{quat}, 1 C, 7). – **MS** (Cl, NH₃): *m/z* (%) = 285.9 (16) [MH⁺ - C₄H₈], 303.0 (46) [MNH₄⁺ - C₄H₈], 342.0 (100) [MH⁺], 359.0 (10) [MNH₄⁺]. – **IR** (neat) [cm⁻¹]: $\tilde{\nu}$ = 2978, 2883, 2360, 2342, 1734, 1653, 1521, 1490, 1369, 1253, 1150, 1135, 1073, 1010, 838, 811, 745. – **MF** C₁₅H₂₁BrClNO₃. – **MW** 378.69.

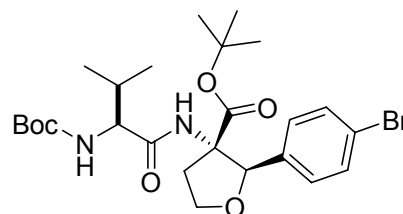

tert-Butyl 2-(4-bromophenyl)-3-((S)-2-(tert-butoxycarbonylamino)-3-methylbutanamido)-tetrahydro-furan-3-carboxylate (**253**):

Under an atmosphere of nitrogen Boc-Val-OH **254** (236 mg, 1.09 mmol, 1.2 eq.) was dissolved in 7.3 ml DMF (8 ml/mmol) and cooled to 0 °C in an ice bath. To the solution DIPEA (558 μ l, 3.26 mmol, 3.6 eq.), HOBt (226 mg, 1.63 mmol, 1.8 eq.) and EDC (289 μ g, 1.63 mmol, 1.8 eq.) were added in this sequence. Then compound *rac*-**136** (350 mg, 0.91 mmol, 1.0 eq.) was slowly added in portions. The mixture was allowed to warm to room temperature and stirred for 24 hours. The reaction was quenched with 14 ml of water and 4 ml of 1M aqueous KHSO₄ and extracted with diethyl ether (3x14 ml). The combined organic layers were washed twice with brine. Afterwards the solution was dried over MgSO₄ and concentrated under reduced pressure. The crude product was then purified by column chromatography on flash silica gel (PE:diethyl ether 60:40; R_f = 0.14) to give the product as colorless solid in 70 % yield (340 mg, 0.63 mmol).

MP 139-140 °C. – **¹H-NMR** (300 MHz, CDCl₃): δ = 0.93-1.06 (m, 6 H, CH₃), 1.08-1.15 (m, 9 H, ^tBu-CH₃), 1.46-1.49 (m, 9 H, Boc-CH₃), 2.10-2.34 (m, 1 H, CH), 2.46-2.72 (m, 2 H, CH₂), 3.85-4.04 (m, 1 H, CH), 4.25-4.41 (m, 2 H, OCH₂), 4.91-5.11 (m, 1 H, CH), 7.18-7.24 (m, 2 H, CH-Ar), 7.35-7.44 (m, 2 H, CH-Ar). – **¹³C-NMR** (75 MHz, CDCl₃): δ = 17.5 (+, 1 C, CH₃), 19.4/19.6 (+, 1 C, CH₃), 27.4 (+, 3 C, ^tBu-CH₃), 28.3 (+, 3 C, Boc-CH₃), 30.4/30.5 (+, 1 C, CH), 35.4/35.7 (-, 1 C, CH₂), 60.4/60.7 (+, 1 C, CH), 67.9/68.0 (-, 1 C, OCH₂), 69.6 (C_{quat}, 1 C, CNH), 83.1 (C_{quat}, 2 C, C(CH₃)₃), 83.2 (+, 1 C, CH), 121.5/121.6 (C_{quat}, 1 C, C-Br), 127.7 (+, 2 C, CH-Ar), 130.9/131.0 (+, 2 C, CH-Ar), 136.7 (C_{quat}, 1 C, C-Ar), 155.9 (C_{quat}, 1 C, Boc-CO), 170.0/170.1 (C_{quat}, 1 C, CO), 170.9/171.1 (C_{quat}, 1 C, CO). – **MS** (ES, DCM/MeOH + 10 mmol/l NH₄OAc): *m/z* (%) = 429.0 (84) [MH⁺ - 2 C₄H₈], 485.0 (67) [MH⁺ - C₄H₈], 541.0 (100) [MH⁺], 563.0 (39) [MNa⁺]. – **Elemental analysis** calcd. (%) for C₂₅H₃₇BrN₂O₆ (541.48): C 55.45, H 6.89, N 5.17; found: C 55.35, H 6.82, N 4.89. – **IR** (neat) [cm⁻¹]: $\tilde{\nu}$ = 3390, 3323, 2972, 2934, 2875, 1705, 1664, 1510, 1366, 1254, 1157, 1071, 1012, 834, 648. – **MF** C₂₅H₃₇BrN₂O₆. – **MW** 541.48.

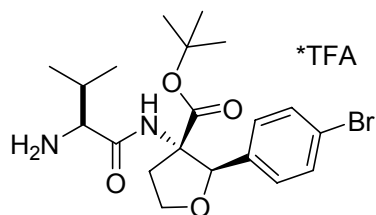

tert-Butyl 3-((S)-2-amino-3-methylbutanamido)-2-(4-bromophenyl)-tetrahydrofuran-3-carboxylate · TFA (254):

Compound **253** (500 mg, 0.92 mmol) was dissolved under ice bath cooling in 18.4 ml of a 8 % TFA containing dry DCM solution (20 ml/mmol), which was prepared in advance. The reaction mixture was stirred for 5 hours and reaction progress was monitored by TLC (EtOAc). The solvent was evaporated under reduced pressure to give the product as pale yellow very hygroscopic solid in quantitative yield (504 mg, 0.91 mmol).

MP > 180 °C. – **¹H-NMR** (300 MHz, MeOH-*d*₄): δ = 0.99-1.20 (m, 15 H, CH₃), 2.16-2.42 (m, 2 H, CH + CH₂), 2.83-3.01 (m, 1 H, CH₂), 3.68-3.85 (m, 1 H, CH₂), 3.89-4.08 (m, 1 H, CH₂), 4.29-4.44 (m, 1 H, CH), 4.95-5.08 (m, 1 H, CH), 7.23-7.31 (m, 2 H, Ar-CH), 7.48 (d, ³J_{H,H} = 8.5, 2 H, Ar-CH). – **¹³C-NMR** (75 MHz, MeOH-*d*₄): δ = 17.5/18.2 (+, 1 C, CH₃), 19.0/19.2 (+, 1 C, CH₃), 27.7/27.8 (+, 3 C, CH₃), 28.2 (+, 1 C, CH), 31.6/31.8 (-, 1 C, CH₂), 59.4/59.6 (+, 1 C, CH), 68.9/69.1 (-, 1 C, CH₂), 72.0 (C_{quat}, 1 C, NH-C), 83.8 (C_{quat}, 1 C, C-^tBu), 87.3/87.4 (+, 1 C, CH), 123.2 (C_{quat}, 1 C, C-Br), 130.2/130.2 (+, 2 C, Ar-CH), 132.2 (+, 2 C, Ar-CH), 138.5 (C_{quat}, 1 C, Ar-C), 169.5 (C_{quat}, 1 C, CO), 169.9 (C_{quat}, 1 C, CO). – **MS** (ES, MeOH): *m/z* (%) = 441.0 (65) [MH⁺], 462.8 (100) [MNa⁺]. – **IR** (neat) [cm⁻¹]: $\tilde{\nu}$ = 3354, 2970, 2943, 2361, 2342, 1668, 1519, 1259, 1118, 1011, 831, 721. – **MF** C₂₂H₃₀BrF₃N₂O₆. – **MW** 554.38.

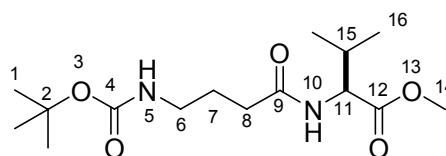

(S)-Methyl 2-(4-(tert-butoxycarbonylamino)butanamido)-3-methylbutanoate (227):

Under an atmosphere of nitrogen 4-(tert-butoxycarbonylamino)butanoic acid **224** (1.50 mg, 7.38 mmol, 1 eq.) was dissolved in 14.7 ml DCM (2 ml/mmol) and cooled to 0 °C in an ice bath. To the solution DIPEA (3.79 ml, 22.1 mmol, 3 eq.), HOBt (1.51 g, 11.1 mmol, 1.5 eq.) and EDC (1.96 ml, 11.1 mmol, 1.5 eq.) were added in this sequence. Then H-Val-OMe · HCl **226** (1.86 g, 11.1 mmol, 1.5 eq.) was slowly added in portions. The mixture was allowed to warm to room temperature and stirred for 24 hours. The reaction was quenched with 15 ml of water and 15 ml of 1M aqueous KHSO₄ and extracted with diethyl ether (3x40 ml). The combined organic layers were washed with brine. Afterwards the solution was dried over MgSO₄ and concentrated under reduced pressure. The crude product was then purified by column chromatography on flash silica gel (EE:PE 40:60; R_f = 0.16) to give the product as colorless oil in 81 % yield (1.89 mg, 5.97 mmol).

¹H-NMR (300 MHz, CDCl₃): δ = 0.94 (t, ³J_{H,H} = 7.3, 6 H, 14), 1.44 (s, 9 H, 1), 1.81 (quintet, ³J_{H,H} = 6.8, 2 H, 7), 2.11-2.24 (m, 1 H, 15), 2.29 (t, ³J_{H,H} = 7.0, 2 H, 8), 3.09-3.34 (m, 2 H, 6), 3.73 (s, 3 H, 14), 4.54 (dd, ³J_{H,H} = 4.9, ³J_{H,H} = 8.5, 1 H, 11), 4.73 (bs, 1 H, 5), 6.57 (bs, 1 H, 10). – **¹³C-NMR** (75 MHz, CDCl₃): δ = 17.8 (+, 1 C, 16), 19.0 (+, 1 C, 16), 26.5 (-, 1 C, 7), 28.4 (+, 3 C, 1), 31.0 (+, 1 C, 8), 39.6 (-, 1 C, 8), 39.6 (-, 1 C, 6), 52.1 (+, 1 C, 14), 57.2 (+, 1 C, 11), 79.3 (C_{quat}, 1 C, 2), 156.5 (C_{quat}, 1 C, 4), 172.7 (C_{quat}, 1 C, 9/12), 172.7 (C_{quat}, 1 C, 9/12). – **MS** (CI, NH₃): *m/z* (%) = 217.2 (10) [MH⁺ - Boc], 261.2 (24) [MH⁺ - C₄H₈], 278.2 (7) [MNH₄⁺ - C₄H₈], 317.3 (100) [MH⁺], 334.3 (5) [MNH₄⁺]. – **IR** (neat) [cm⁻¹]: $\tilde{\nu}$ = 3356, 2969, 2875, 2360, 2341, 1714, 1514, 1366, 1260, 1159, 1075, 1012, 830. – **MF** C₁₅H₂₈N₂O₅. – **MW** 316.39.

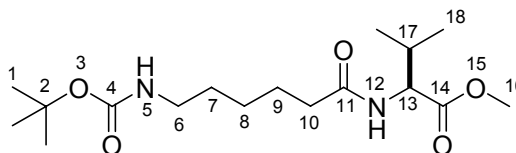

(S)-Methyl 2-(6-(tert-butoxycarbonylamino)hexanamido)-3-methylbutanoate (228):

Under an atmosphere of nitrogen 6-(tert-butoxycarbonylamino)hexanoic acid **225** (1.50 mg, 6.49 mmol, 1 eq.) was dissolved in 13.0 ml DCM (2 ml/mmol) and cooled to 0 °C in an ice bath. To the solution DIPEA (3.33 ml, 19.5 mmol, 3 eq.), HOBt (1.32 g, 9.73 mmol, 1.5 eq.) and EDC (1.72 ml, 9.73 mmol, 1.5 eq.) were added in this sequence. Then H-Val-OMe · HCl **226** (1.63 g, 9.73 mmol, 1.5 eq.) was slowly added in portions. The mixture was allowed to warm to room temperature and stirred for 24 hours. The reaction was quenched with 13 ml of water and 13 ml of 1M aqueous KHSO₄ and extracted with diethyl ether (3x40 ml). The combined organic layers were washed with brine. Afterwards the solution was dried over MgSO₄ and concentrated under reduced pressure. The crude product was then purified by column chromatography on flash silica gel (EtOAc:PE 40:60; R_f = 0.18) to give the product as colorless oil in 80 % yield (1.78 mg, 5.17 mmol).

¹H-NMR (300 MHz, CDCl₃): δ = 0.89 (d, ³J_{H,H} = 6.9, 3 H, 18), 0.93 (d, ³J_{H,H} = 6.9, 3 H, 18), 1.32-1.56 (m, 13 H, 1 + 7 + 8), 1.67 (quintet, ³J_{H,H} = 7.5, 2 H, 9), 2.14 (dq, ³J_{H,H} = 4.9, ³J_{H,H} = 6.9, 1 H, 15), 2.24 (t, ³J_{H,H} = 7.4, 2 H, 10), 3.10 (dd, ³J_{H,H} = 6.3, ²J_{H,H} = 12.3, 2 H, 6), 3.74 (s, 3 H, 16), 4.48-4.63 (m, 2 H, 5 + 13), 5.09 (d, ³J_{H,H} = 8.2, 1 H, 12). – **¹³C-NMR** (75 MHz, CDCl₃): δ = 17.8 (+, 1 C, 18), 18.9 (+, 1 C, 18), 25.2 (-, 1 C, 9), 26.3 (-, 1 C, 8), 28.4 (+, 3 C, 1), 29.7 (-, 1 C, 7), 31.2 (+, 1 C, 17), 36.4 (-, 1 C, 10), 40.4 (-, 1 C, 6), 52.1 (+, 1 C, 16), 56.9 (+, 1 C, 13), 79.0 (C_{quat}, 1 C, 2) 156.0 (C_{quat}, 1 C, 4), 172.8 (C_{quat}, 1 C, 11/14), 172.8 (C_{quat}, 1 C, 11/14). – **MS** (Cl, NH₃): *m/z* (%) = 245.2 (27) [MH⁺ - Boc], 289.3 (51) [MH⁺ - C₄H₈], 306.2 (23) [MNH₄⁺ - C₄H₈], 345.3 (100) [MH⁺], 362.3 (17) [MNH₄⁺]. – **IR** (neat) [cm⁻¹]: $\tilde{\nu}$ = 3364, 3242, 2969, 2930, 2361, 2341, 1668, 1519, 1463, 1259, 1226, 1118, 994, 829. – **MF** C₁₇H₃₂N₂O₅. – **MW** 344,45.

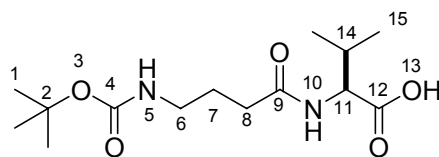

(S)-2-(4-(tert-Butoxycarbonylamino)butanamido)-3-methylbutanoic acid (229):

The ester **227** (1.00 g, 3.16 mmol) was dissolved in 32 ml of a MeCN:water mixture (4:1, 10 ml/mmol). To the solution 1M aqueous LiOH (3.48 ml, 3.48 mmol, 1.1 eq.) was slowly added. The mixture was stirred over night. After acidification with 1M aqueous KHSO₄ solution the mixture was extracted with DCM (3x30 ml). The combined organic layers were dried over MgSO₄ and concentrated under reduced pressure to give the product as colorless solid in 84 % yield. (800 mg, 2.65 mmol)

MP 58-59 °C. – **¹H-NMR** (300 MHz, CDCl₃): δ = 0.77-0.98 (m, 6 H, 15), 1.24-1.53 (m, 9 H, 1), 1.61-1.90 (m, 2 H, 7), 2.05-2.41 (m, 3 H, 8 + 14), 2.94-3.37 (m, 2 H, 6), 4.68 (s, 1 H, 11), 6.66 (bs, 1 H, 5), 7.34 (d, ³J_{H,H} = 8.5, 1 H, 10), 10.99 (bs, 1 H, 13). – **¹³C-NMR** (75 MHz, CDCl₃): δ = 17.9 (+, 1 C, 15), 19.1 (+, 1 C, 15), 26.3 (-, 1 C, 7), 28.3 (+, 3 C, 1), 31.9 (+, 1 C, 14), 32.9 (-, 1 C, 8), 39.6 (-, 1 C, 6), 56.8 (+, 1 C, 11), 81.7 (C_{quat}, 1 C, 2), 158.5 (C_{quat}, 1 C, 4), 172.7 (C_{quat}, 1 C, 9), 176.3 (C_{quat}, 1 C, 12). – **MS** (Cl, NH₃): *m/z* (%) = 203.2 (9) [MH⁺ - Boc], 247.1 (30) [MH⁺ - C₄H₈], 264.2 (10) [MNH₄⁺ - C₄H₈], 303.2 (100) [MH⁺], 320.2 (5) [MNH₄⁺]. – **IR** (neat) [cm⁻¹]: $\tilde{\nu}$ = 3358, 2970, 2873, 2360, 2339, 1712, 1517, 1365, 1259, 1163, 1075, 1011, 828. – **MF** C₁₄H₂₆N₂O₅. – **MW** 302.37.

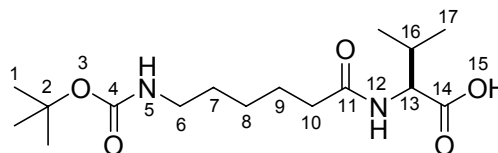

(S)-2-(4-(tert-Butoxycarbonylamino)butanamido)-3-methylbutanoic acid (230):

The ester **228** (1.00 g, 2.90 mmol) was dissolved in 29 ml of a MeCN:water mixture (4:1, 10 ml/mmol). To the solution 1M aqueous LiOH (3.19 ml, 3.19 mmol, 1.1 eq.) was slowly added. The mixture was stirred over night. After acidification with 1M aqueous KHSO₄ solution the mixture was extracted with DCM (3x30 ml). The combined organic layers were dried over MgSO₄ and concentrated under reduced pressure to give the product as colorless solid in 91 % yield. (870 mg, 2.63 mmol)

MP 116 °C. – **¹H-NMR** (300 MHz, CDCl₃): δ = 0.92 (d, ³J_{H,H} = 6.9, 3 H, 17), 0.95 (d, ³J_{H,H} = 6.9, 3 H, 17), 1.24-1.53 (m, 13 H, 1 + 7 + 8), 1.64 (quintet, ³J_{H,H} = 7.1, 2 H, 9), 2.13-2.32 (m, ³J_{H,H} = 7.1, 2 H, 10 + 16), 3.07 (bs, 2 H, 6), 4.56 (dd, ³J_{H,H} = 4.9, ³J_{H,H} = 8.8, 1 H, 13), 4.75 (bs, 1 H, 5), 6.52-6.68 (m, 1 H, 12), 10.56 (bs, 1 H, 15). – **¹³C-NMR** (75 MHz, CDCl₃): δ = 17.7 (+, 1 C, 17), 19.1 (+, 1 C, 17), 25.3 (-, 1 C, 9), 26.2 (-, 1 C, 8), 28.4 (+, 3 C, 1), 29.6 (-, 1 C, 7), 30.9 (+, 1 C, 16), 36.3 (-, 1 C, 10), 40.4 (-, 1 C, 6), 57.1 (+, 1 C, 13), 79.4 (C_{quat}, 1 C, 2), 156.4 (C_{quat}, 1 C, 4), 174.0 (C_{quat}, 1 C, 11), 174.8 (C_{quat}, 1 C, 14). – **MS** (CI, NH₃): *m/z* (%) = 231.2 (18) [MH⁺ - Boc], 275.2 (36) [MH⁺ - C₄H₈], 292.2 (38) [MNH₄⁺ - C₄H₈], 331.2 (100) [MH⁺], 348.2 (35) [MNH₄⁺]. – **IR** (neat) [cm⁻¹]: $\tilde{\nu}$ = 3362, 3245, 2970, 2928, 2362, 2341, 1667, 1521, 1462, 1255, 1226, 1116, 994, 831. – **MF** C₁₆H₃₀N₂O₅. – **MW** 330.42.

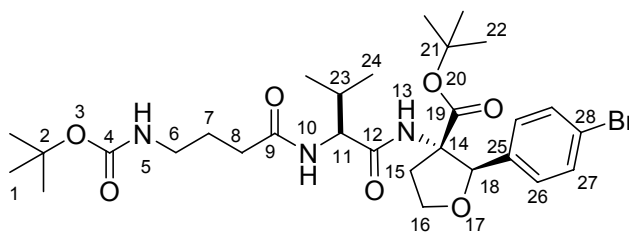

tert-Butyl 2-(4-bromophenyl)-3-((S)-2-(4-(tert-butoxycarbonylamino)butanamido)-3-methylbutan-amido)-tetrahydrofuran-3-carboxylate (231):

Under an atmosphere of nitrogen compound **229** (500 mg, 1.65 mmol, 1 eq.) was dissolved in 6.6 ml DMF (4 ml/mmol) and cooled to 0 °C in an ice bath. To the solution DIPEA (849 μ l, 4.96 mmol, 3 eq.), HOAt (338 mg, 2.48 mmol, 1.5 eq.) and HATU (943 mg, 2.48 mmol, 1.5 eq.) were added in this sequence. Then compound *rac*-**136** (905 mg, 1.98 mmol, 1.2 eq.) was slowly added in portions. The mixture was allowed to warm to room temperature and stirred for 24 hours. The reaction was quenched with 13 ml of water and 3 ml of 1M aqueous KHSO_4 and extracted with diethyl ether (3x20 ml). The combined organic layers were washed twice with brine. Afterwards the solution was dried over MgSO_4 and concentrated under reduced pressure. The crude product was then purified by column chromatography on flash silica gel (DCM:MeOH 98:2; R_f = 0.08) to give the product as colorless solid in 58 % yield (602 mg, 0.96 mmol).

MP 72-73 °C. – **$^1\text{H-NMR}$** (300 MHz, CDCl_3): δ = 0.93 (d, $^3J_{\text{H,H}}$ = 6.5, 3 H, 24), 0.93 (d, $^3J_{\text{H,H}}$ = 6.3, 3 H, 24), 1.02 (s, 9 H, 22), 1.36 (s, 9 H, 1), 1.75 (quintet, $^3J_{\text{H,H}}$ = 6.3, 2 H, 7), 2.05-2.18 (m, 1 H, 23), 2.24 (t, $^3J_{\text{H,H}}$ = 7.0, 2 H, 8), 2.40-2.51 (m, 1 H, 15), 2.57-2.70 (m, 1 H, 15), 2.97-3.19 (m, 2 H, 6), 4.11 (q, $^3J_{\text{H,H}}$ = 8.1, 1 H, 16), 4.23 (dt, $^2J_{\text{H,H}}$ = 3.3, $^3J_{\text{H,H}}$ = 8.2, 1 H, 16), 4.31 (t, $^3J_{\text{H,H}}$ = 7.3, 1 H, 11), 4.92 (t, $^3J_{\text{H,H}}$ = 4.9, 1 H, NH), 5.07 (s, 1 H, 18), 6.99 (d, $^3J_{\text{H,H}}$ = 7.9, 1 H, NH), 7.16 (d, $^3J_{\text{H,H}}$ = 8.2, 2 H, 26), 7.34 (d, $^3J_{\text{H,H}}$ = 8.5, 2 H, 27), 7.67 (d, $^3J_{\text{H,H}}$ = 4.9, 1 H, NH). – **$^{13}\text{C-NMR}$** (75 MHz, CDCl_3): δ = 18.1 (+, 1 C, 24), 19.5 (+, 1 C, 24), 26.7 (-, 1 C, 7), 27.3 (+, 3 C, 1), 28.4 (+, 3 C, 22), 30.6 (+, 1 C, 23), 33.4 (-, 1 C, 15), 35.7 (-, 1 C, 8), 39.6 (-, 1 C, 6), 58.9 (+, 1 C, 11), 67.9 (-, 1 C, 16), 69.9 (C_{quat} , 1 C, 14), 79.4 (C_{quat} , 1 C, 2), 82.7 (C_{quat} , 1 C, 21), 84.1 (+, 1 C, 18), 121.7 (C_{quat} , 1 C, 28), 128.1 (+, 2 C, 26), 131.0 (+, 2 C, 27), 136.8 (C_{quat} , 1 C, 25), 156.6 (C_{quat} , 1 C, 4), 169.3 (C_{quat} , 1 C, 12), 171.0 (C_{quat} , 1 C, 19), 173.2 (C_{quat} , 1 C, 9). – **MS** (ES, MeOH): m/z (%) = 648.1 (100) [MNa^+], 664.1 (17) [MK^+]. – **HR-MS** (PI-EIMS): [M^+] calcd. for $\text{C}_{29}\text{H}_{44}\text{BrN}_3\text{O}_7$ 625.2363; found 625.2350. – **IR** (neat) [cm^{-1}]: $\tilde{\nu}$ = 3281, 2974, 2931, 2877, 1714, 1637, 1528, 1366, 1251, 1161, 1011, 846, 647. – **MF** $\text{C}_{29}\text{H}_{44}\text{BrN}_3\text{O}_7$. – **MW** 626.58.

Alternative synthesis for compound 231:

Under an atmosphere of nitrogen compound **224** (238 mg, 1.17 mmol, 1.4 eq.) was dissolved in 5.0 ml DMF (6 ml/mmol) and cooled to 0 °C in an ice bath. To the solution DIPEA (602 μ l, 3.52 mmol, 4.2 eq.), HOAt (239 mg, 1.76 mmol, 2.1 eq.) and HATU (669 mg, 1.76 mmol, 2.1 eq.) were added in this sequence. Then compound **254** (400 mg, 0.84 mmol, 1 eq.) was slowly added in portions. The mixture was allowed to warm to room temperature and stirred for 24 hours. The reaction was quenched with 10 ml of water and 3 ml of 1M aqueous KHSO₄ and extracted with diethyl ether (3x15 ml). The combined organic layers were washed twice with brine. Afterwards the solution was dried over MgSO₄ and concentrated under reduced pressure. The crude product was then purified by column chromatography on flash silica gel (DCM:MeOH 98:2; R_f = 0.08) to give the product as colorless solid in 67 % yield (350 mg, 0.56 mmol).

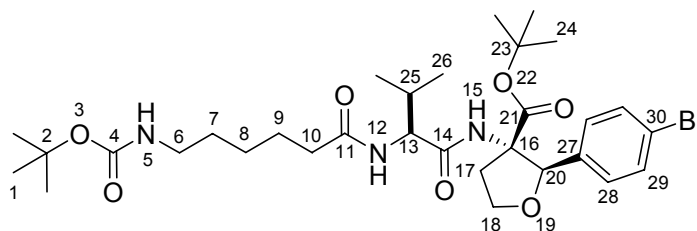

tert-Butyl 2-(4-bromophenyl)-3-((S)-2-(6-(tert-butoxycarbonylamino)hexanamido)-3-methylbutanamido)-tetrahydrofuran-3-carboxylate (**232**):

Under an atmosphere of nitrogen compound **230** (500 mg, 1.51 mmol, 1 eq.) was dissolved in 6.0 ml DMF (4 ml/mmol) and cooled to 0 °C in an ice bath. To the solution DIPEA (777 μ l, 4.54 mmol, 3 eq.), HOAt (309 mg, 2.27 mmol, 1.5 eq.) and HATU (863 mg, 2.27 mmol, 1.5 eq.) were added in this sequence. Then compound *rac*-**136** (828 mg, 1.82 mmol, 1.2 eq.) was slowly added in portions. The mixture was allowed to warm to room temperature and stirred for 24 hours. The reaction was quenched with 12 ml of water and 3 ml of 1M aqueous KHSO_4 and extracted with diethyl ether (3x18 ml). The combined organic layers were washed twice with brine. Afterwards the solution was dried over MgSO_4 and concentrated under reduced pressure. The crude product was then purified by column chromatography on flash silica gel (DCM:MeOH 98:2; R_f = 0.11) to give the product as colorless solid in 69 % yield (680 mg, 1.04 mmol).

MP 61-62 °C. – **$^1\text{H-NMR}$** (300 MHz, CDCl_3): δ = 0.97 (d, $^3J_{\text{H,H}}$ = 6.3, 3 H, 26), 0.99 (d, $^3J_{\text{H,H}}$ = 6.3, 3 H, 26), 1.08 (s, 9 H, 24), 1.27-1.36 (m, 2 H, 8), 1.39-1.50 (m, 11 H, 1 + 7), 1.59-1.71 (m, 2 H, 9), 2.11 (q, $^3J_{\text{H,H}}$ = 6.5, 2 H, 25), 2.24 (t, $^3J_{\text{H,H}}$ = 7.5, 2 H, 10), 2.44-2.55 (m, 1 H, 17), 2.63-2.74 (m, 1 H, 17), 3.00-3.11 (m, 2 H, 6), 4.19 (q, $^3J_{\text{H,H}}$ = 8.4, 1 H, 18), 4.23 (dt, $^2J_{\text{H,H}}$ = 3.5, $^3J_{\text{H,H}}$ = 8.3, 1 H, 18), 4.34-4.42 (m, 1 H, 13), 4.61 (bs, 1 H, NH), 5.13 (s, 1 H, 20), 6.36 (dd, $^3J_{\text{H,H}}$ = 5.1, $^3J_{\text{H,H}}$ = 8.0, 1 H, NH), 7.22 (d, $^3J_{\text{H,H}}$ = 8.5, 2 H, 28), 7.41 (d, $^3J_{\text{H,H}}$ = 8.5, 2 H, 29), 7.57 (d, $^3J_{\text{H,H}}$ = 8.5, 1 H, NH). – **$^{13}\text{C-NMR}$** (75 MHz, CDCl_3): δ = 18.3 (+, 1 C, 24), 19.4 (+, 1 C, 24), 25.4 (- 1 C, 9), 26.4 (-, 1 C, 8), 27.4 (+, 3 C, 1), 28.4 (+, 3 C, 24), 29.7 (- 1 C, 7), 31.1 (+, 1 C, 25), 35.8 (-, 1 C, 17), 36.5 (-, 1 C, 10), 38.7 (-, 1 C, 6), 58.6 (+, 1 C, 13), 67.9 (-, 1 C, 18), 69.8 (C_{quat} , 1 C, 16), 79.1 (C_{quat} , 1 C, 2), 82.9 (C_{quat} , 1 C, 23), 84.0 (+, 1 C, 20), 121.7 (C_{quat} , 1 C, 30), 128.0 (+, 2 C, 28), 131.0 (+, 2 C, 29), 136.6 (C_{quat} , 1 C, 27), 156.0 (C_{quat} , 1 C, 4), 169.4 (C_{quat} , 1 C, 14), 171.8 (C_{quat} , 1 C, 21), 173.2 (C_{quat} , 1 C, 11). – **MS** (ES, MeOH): m/z (%) = 676.2 (100) [MNa^+], 692.2 (15) [MK^+]. – **HR-MS** (PI-EIMS): [M^+] calcd. for $\text{C}_{31}\text{H}_{48}\text{BrN}_3\text{O}_7$ 653.2676; found 653.2662. – **IR** (neat) [cm^{-1}]: $\tilde{\nu}$ = 3349, 2941, 2534, 2362, 2341, 1667, 1517, 1453, 1365, 1259, 1226, 1117, 994, 828, 686. – **MF** $\text{C}_{31}\text{H}_{48}\text{BrN}_3\text{O}_7$. – **MW** 654.63.

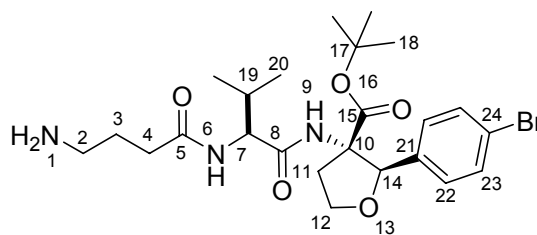

tert-Butyl 3-((S)-2-(4-aminobutanamido)-3-methylbutanamido)-2-(4-bromophenyl)-tetrahydrofuran-3-carboxylate (**233**):

Compound **231** (200 mg, 0.32 mmol) was dissolved under ice bath cooling in 6.4 ml of a 8 % TFA containing dry DCM solution (20 ml/mmol), which was prepared in advance. The reaction mixture was stirred for 5 hours and reaction progress was monitored by TLC (EtOAc). The solvent was evaporated and the crude product was dissolved in methanol water mixture (1:1) and purified over an ion exchanger column using a strongly basic ion exchange resin. The pure product was obtained as colorless solid in quantitative yield. (168 mg, 0.32 mmol)

MP 62 °C. – **¹H-NMR** (300 MHz, MeOH-*d*₄): δ = 0.93-1.11 (m, 15 H, 18 + 20), 1.78 (quintet, ³J_{H,H} = 7.3, 2 H, 3), 2.00-2.13 (m, 1 H, 19), 2.25 (dd, ³J_{H,H} = 2.7, ³J_{H,H} = 6.6, 1 H, 11), 2.32 (t, ³J_{H,H} = 7.6, 2 H, 4), 2.66 (t, ³J_{H,H} = 7.1, 2 H, 2), 2.89 (ddd, ³J_{H,H} = 8.4, ³J_{H,H} = 9.7, ³J_{H,H} = 13.0, 1 H, 11), 4.01 (ddd, ³J_{H,H} = 6.6, ³J_{H,H} = 8.4, ³J_{H,H} = 9.7, 1 H, 12), 4.17 (d, ³J_{H,H} = 7.7, 1 H, 7), 4.29 (dt, ³J_{H,H} = 2.8, ³J_{H,H} = 8.3, 1 H, 12), 4.99 (s, 1 H, 14), 7.27 (d, ³J_{H,H} = 8.2, 2 H, 22), 7.47 (d, ³J_{H,H} = 8.5, 2 H, 23). – **¹³C-NMR** (75 MHz, MeOH-*d*₄): δ = 19.2 (+, 1 C, 20), 20.1 (+, 1 C, 20), 27.8 (+, 3 C, 18), 29.3 (-, 1 C, 3), 31.6 (+, 1 C, 19), 34.1 (-, 1 C, 11), 37.0 (-, 1 C, 4), 41.8 (-, 1 C, 2), 60.4 (+, 1 C, 7), 68.9 (-, 1 C, 12), 71.8 (C_{quat}, 1 C, 10), 83.1 (C_{quat}, 1 C, 17), 86.9 (+, 1 C, 14), 123.0 (C_{quat}, 1 C, 24), 130.3 (+, 2 C, 22), 132.1 (+, 2 C, 23), 138.7 (C_{quat}, 1 C, 21), 170.0 (C_{quat}, 1 C, 8), 173.6 (C_{quat}, 1 C, 15), 175.8 (C_{quat}, 1 C, 5). – **MS** (ES, MeOH): *m/z* (%) = 526.1 (33) [MH⁺], 548.1 (100) [M + Na⁺]. – **IR** (neat) [cm⁻¹]: $\tilde{\nu}$ = 3269, 2968, 2936, 2330, 1732, 1636, 1528, 1368, 1253, 1161, 1072, 1011, 837. – **MF** C₂₄H₃₆BrN₃O₅. – **MW** 526.46.

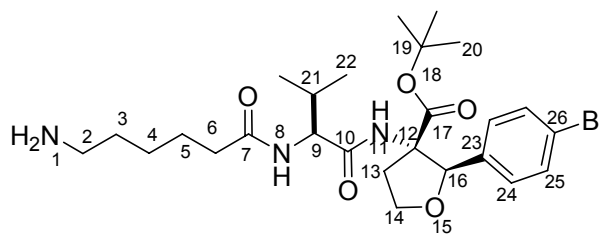

tert-Butyl 3-((S)-2-(6-aminohexanamido)-3-methylbutanamido)-2-(4-bromophenyl)-tetrahydrofuran-3-carboxylate (195):

Compound **232** (300 mg, 0.46 mmol) was dissolved under ice bath cooling in 9.2 ml of a 8 % TFA containing dry DCM solution (20 ml/mmol), which was prepared in advance. The reaction mixture was stirred for 5 hours and reaction progress was monitored by TLC (EtOAc). The solvent was evaporated and the crude product was dissolved in methanol water mixture (1:1) and purified over an ion exchanger column using a strongly basic ion exchange resin. The pure product was obtained as colorless solid in 89 % yield. (228 mg, 0.41 mmol)

MP 74 °C. – **¹H-NMR** (300 MHz, MeOH-*d*₄): δ = 0.95-1.09 (m, 15 H, 20 + 22), 1.30-1.44 (m, 2 H, 4), 1.51-1.74 (m, 4 H, 3 + 5), 1.99-2.13 (m, 1 H, 21), 2.22 – 2.35 (m, 3 H, 6 + 13), 2.76 (t, ³J_{H,H} = 7.6, 2 H, 2), 2.89 (ddd, ³J_{H,H} = 8.4, ³J_{H,H} = 9.7, ³J_{H,H} = 13.0, 1 H, 13), 4.01 (ddd, ³J_{H,H} = 6.8, ³J_{H,H} = 8.3, ³J_{H,H} = 9.7, 1 H, 14), 4.17 (d, ³J_{H,H} = 7.7, 1 H, 9), 4.29 (dt, ³J_{H,H} = 2.7, ³J_{H,H} = 8.2, 1 H, 14), 5.01 (s, 1 H, 16), 7.27 (d, ³J_{H,H} = 8.5, 2 H, 24), 7.47 (d, ³J_{H,H} = 8.5, 2 H, 25). – **¹³C-NMR** (75 MHz, MeOH-*d*₄): δ = 19.3 (+, 1 C, 22), 20.1 (+, 1 C, 22), 26.6 (-, 1 C, 5), 27.3 (-, 1 C, 4), 27.8 (+, 3 C, 20), 30.7 (-, 1 C, 3), 31.5 (+, 1 C, 21), 36.5 (-, 1 C, 13), 37.1 (-, 1 C, 6), 41.4 (-, 1 C, 2), 60.5 (+, 1 C, 9), 68.9 (-, 1 C, 14), 71.8 (C_{quat}, 1 C, 12), 83.1 (C_{quat}, 1 C, 19), 86.8 (+, 1 C, 16), 123.1 (C_{quat}, 1 C, 26), 130.3 (+, 2 C, 24), 132.2 (+, 2 C, 25), 138.7 (C_{quat}, 1 C, 23), 170.0 (C_{quat}, 1 C, 10), 173.7 (C_{quat}, 1 C, 17), 176.2 (C_{quat}, 1 C, 7). – **MS** (CI, NH₃): *m/z* (%) = 554.1 (100) [MH⁺]. – **IR** (neat) [cm⁻¹]: $\tilde{\nu}$ = 3271, 2970, 2938, 2320, 1730, 1639, 1531, 1370, 1164, 1073, 1011, 835. – **MF** C₂₆H₄₀BrN₃O₅. – **MW** 554.52.

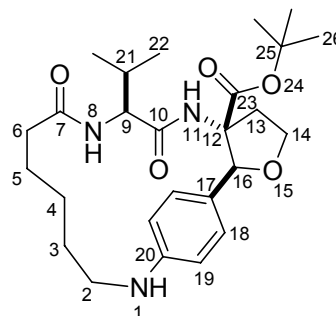
**Compound 196:**

The synthesis followed **GP2** using compound **195** (40 mg, 0.07 mmol), K_2CO_3 (20 mg, 0.14 mmol), CuI (3 mg, 0.01 mmol), L-proline (3 mg, 0.03 mmol) and 0.7 ml DMSO. The crude product was purified using a 6:4 mixture of PE and EtOAc ($R_f = 0.09$) giving the product as a colorless solid in 7 % yield. (2.4 mg, 0.004 mmol)

1H -NMR (600 MHz, COSY, $CDCl_3$) $\delta = 0.42$ - 0.47 (m, 1 H, 4), 0.74 - 0.84 (m, 1 H, 4), 0.91 (d, $^3J_{H,H} = 6.6$, 3 H, 22), 0.97 (d, $^3J_{H,H} = 7.0$, 3 H, 22), 1.20 - 1.25 (m, 1 H, 5), 1.40 (s, 9 H, 26), 1.44 - 1.51 (m, 1 H, 5), 1.58 - 1.65 (m, 1 H, 3), 1.74 - 1.84 (m, 1 H, 3), 2.00 (ddd, $^3J_{H,H} = 3.1$, $^3J_{H,H} = 9.7$, $^2J_{H,H} = 16.8$, 1 H, 6), 2.18 (ddd, $^3J_{H,H} = 3.3$, $^3J_{H,H} = 6.8$, $^2J_{H,H} = 16.6$, 1 H, 6), 2.46 (q, $^3J_{H,H} = 10.2$, 1 H, 13), 2.57 - 2.64 (m, 1 H, 21), 2.94 (ddd, $^3J_{H,H} = 3.5$, $^3J_{H,H} = 8.5$, $^2J_{H,H} = 12.4$, 1 H, 13), 3.01 (dd, $^3J_{H,H} = 8.4$, $^2J_{H,H} = 13.4$, 1 H, 2), 3.35 (d, $^3J_{H,H} = 8.9$, 1 H, 9), 3.56 (dd, $^3J_{H,H} = 8.1$, $^2J_{H,H} = 13.4$, 1 H, 2), 4.22 (ddd, $^3J_{H,H} = 3.3$, $^3J_{H,H} = 7.6$, $^2J_{H,H} = 10.9$, 1 H, 14), 4.36 (q, $^3J_{H,H} = 8.1$, 1 H, 14), 5.00 (s, 1 H, 16), 5.70 (d, $^3J_{H,H} = 7.7$, 2 H, 8), 7.35 - 7.52 (m, 4 H, 18 + 19), 7.93 (s, 1 H, NH). – **^{13}C -NMR** (150 MHz, HSQC, HMBC, $CDCl_3$): $\delta = 19.1$ (+, 1 C, 22), 19.7 (+, 1 C, 22), 23.2 (-, 1 C, 5), 26.1 (-, 1 C, 3), 27.3 (-, 1 C, 4), 27.3 (+, 1 C, 21), 28.0 (+, 3 C, 26), 34.1 (-, 1 C, 6), 36.2 (-, 1 C, 13), 50.3 (-, 1 C, 2), 65.9 (-, 1 C, 9), 67.7 (-, 1 C, 14), 69.1 (C_{quat} , 1 C, 12), 82.8 (C_{quat} , 1 C, 25), 84.0 (+, 1 C, 16), 122.3 (+, 2 C, 19), 129.8 (+, 2 C, 18), 135.5 (C_{quat} , 1 C, 17), 136.9 (C_{quat} , 1 C, 20), 169.4 (C_{quat} , 1 C, 23), 172.8 (C_{quat} , 1 C, 10), 173.2 (C_{quat} , 1 C, 7). – **MS** (LCMS, MeCN/ H_2O + 0.1 % TFA): m/z (%) = 418.0 (37) [$MH^+ - C_4H_8$], 474.1 (100) [MH^+], 515.1 (44) [$MH^+ + MeCN$]. – **MF** $C_{26}H_{39}N_3O_5$. – **MW** 473.29.

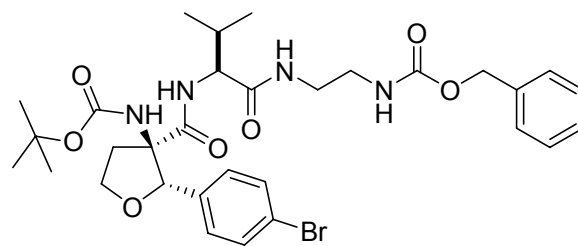

tert-Butyl (2S,3R)-3-((S)-1-(2-(benzyloxycarbonooxylamino)ethylamino)-3-methyl-1-oxobutan-2-ylcarbamoyl)-2-(4-bromophenyl)-tetrahydrofuran-3-ylcarbamate (**236**):

Under an atmosphere of nitrogen compound **181** (330 mg, 0.68 mmol, 1 eq.) was dissolved in 4.1 ml DMF (6 ml/mmol) and cooled to 0 °C in an ice bath. To the solution DIPEA (349 μ l, 2.04 mmol, 3 eq.), HOAt (139 mg, 1.02 mmol, 1.5 eq.) and HATU (388 mg, 1.02 mmol, 1.5 eq.) were added in this sequence. Then benzyl aminoethylcarbamate **50** (185 mg, 0.95 mmol, 1.4 eq.) was slowly added in portions. The mixture was allowed to warm to room temperature and stirred for 24 hours. The reaction was quenched with 8 ml of water and 4 ml of 1M aqueous KHSO₄ and extracted with diethyl ether (3x12 ml). The combined organic layers were washed twice with brine. Afterwards the solution was dried over MgSO₄ and concentrated under reduced pressure. The crude product was then purified by column chromatography on flash silica gel (EE:PE 50:50; R_f = 0.2) to give the product as colorless solid in 65 % yield (291 mg, 0.44 mmol).

MP 153 °C. – **¹H-NMR** (300 MHz, CDCl₃): δ = 0.56 (d, ³J_{H,H} = 6.9, 3 H, Val-CH₃), 0.63 (d, ³J_{H,H} = 6.9, 3 H, Val-CH₃), 1.38 (s, 9 H, Boc-CH₃), 1.87-2.01 (m, 1 H, CH), 2.72-2.87 (m, 1 H, CH₂), 2.90-3.02 (m, 1 H, CH₂), 3.12-3.24 (m, 3 H, CH₂), 3.29-3.40 (m, 1 H, CH₂), 3.55 (t, ³J_{H,H} = 5.8, 1 H, CH₂), 3.95 (q, ³J_{H,H} = 4.0, 1 H, CH), 4.10-4.22 (m, 1 H, CH₂), 4.90 (s, 1 H, CH), 5.00 (s, 2 H, Cbz-CH₂), 5.64 (bs, 1 H, NH), 6.12-6.26 (m, 2 H, NH), 6.68 (bs, 1 H, NH), 7.11 (d, ³J_{H,H} = 8.2, 2 H, CH-Ar), 7.23-7.27 (m, 5 H, Cbz-CH), 7.32 (d, ³J_{H,H} = 8.5, 2 H, CH-Ar). – **¹³C-NMR** (75 MHz, CDCl₃): δ = 17.1 (+, 1 C, CH₃), 19.1 (+, 1 C, CH₃), 28.3 (+, 3 C, CH₃), 29.4 (+, 1 C, CH₃), 36.4 (-, 1 C, CH₂), 39.5 (-, 1 C, CH₂), 40.3 (-, 1 C, CH₂), 59.5 (+, 1 C, CH), 66.6 (-, 1 C, CH₂), 67.3 (-, 1 C, CH₂), 69.1 (C_{quat}, 1 C, NH-C), 81.4 (C_{quat}, 1 C, CO-tBu), 84.1 (+, 1 C, O-CH), 122.4 (C_{quat}, 1 C, C-Br), 127.7-128.5 (+, 7 C, CH-Ar), 131.4 (+, 2 C, CH-Ar), 135.8 (C_{quat}, 1 C, C-Ar), 136.6 (C_{quat}, 1 C, C-Ar), 155.6 (C_{quat}, 1 C, O-CO), 156.8 (C_{quat}, 1 C, O-CO), 171.1 (C_{quat}, 2 C, CONH). – **MS** (ES, DCM/MeOH + 10 mmol/l NH₄OAc): *m/z* (%) = 561.2 (61) [MH⁺ - Boc], 605.2 (40) [MH⁺ - C₄H₈], 661.2 (100) [MH⁺], 683.3 (19) [MNa⁺]. – **HR-MS** (PI-LSIMS, CH₂Cl₂/NBA): [MH⁺] calcd. for C₃₁H₄₂BrN₄O₇ 661.2237; found 661.2235. – **IR** (neat) [cm⁻¹]: $\tilde{\nu}$ = 3348, 3236, 2941, 2841, 2535, 2363, 2340, 1668, 1517, 1453, 1259, 1226, 1117, 994, 828, 686. – **MF** C₃₁H₄₁BrN₄O₇. – **MW** 661.48.

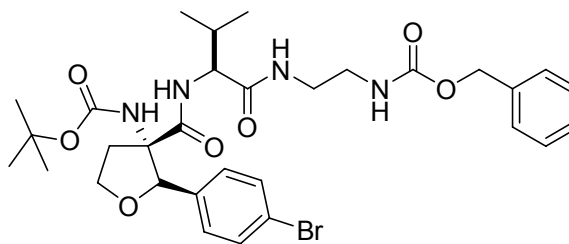

tert-Butyl (2R,3S)-3-((S)-1-(2-(benzyloxycarbonooxylamino)ethylamino)-3-methyl-1-oxobutan-2-ylcarbamoyl)-2-(4-bromophenyl)-tetrahydrofuran-3-ylcarbamate (**238**):

Under an atmosphere of nitrogen compound **183** (470 mg, 0.97 mmol, 1 eq.) was dissolved in 5.8 ml DMF (6 ml/mmol) and cooled to 0 °C in an ice bath. To the solution DIPEA (497 μ l, 2.91 mmol, 3 eq.), HOAt (198 mg, 1.45 mmol, 1.5 eq.) and HATU (552 mg, 1.45 mmol, 1.5 eq.) were added in this sequence. Then benzyl aminoethylcarbamate **50** (263 mg, 1.36 mmol, 1.4 eq.) was slowly added in portions. The mixture was allowed to warm to room temperature and stirred for 24 hours. The reaction was quenched with 12 ml of water and 5 ml of 1M aqueous KHSO₄ and extracted with diethyl ether (3x18 ml). The combined organic layers were washed twice with brine. Afterwards the solution was dried over MgSO₄ and concentrated under reduced pressure. The crude product was then purified by column chromatography on flash silica gel (PE:diethyl ether 60:40; R_f = 0.26) to give the product as colorless solid in 68 % yield (450 mg, 0.66 mmol).

MP 160 °C. – **¹H-NMR** (300 MHz, CDCl₃): δ = 0.66 (d, ³J_{H,H} = 6.9, 3 H, Val-CH₃), 0.71 (d, ³J_{H,H} = 6.9, 3 H, Val-CH₃), 1.45 (s, 9 H, Boc-CH₃), 2.00-2.18 (m, 1 H, CH), 2.29-2.45 (m, 1 H, CH₂), 2.72-2.89 (m, 1 H, CH₂), 2.94-3.08 (m, 1 H, CH₂), 3.19-3.43 (m, 3 H, CH₂), 3.67 (dd, ³J_{H,H} = 4.8, ³J_{H,H} = 6.2, 1 H, CH₂), 4.00-4.13 (m, 1 H, CH), 4.17-4.29 (m, 1 H, CH₂), 5.03 (s, 1 H, CH), 5.07 (s, 2 H, Cbz-CH₂), 5.47 (bs, 1 H, NH), 5.94 (m, 2 H, NH), 6.17-6.33 (bs, 2 H, NH), 7.18 (d, ³J_{H,H} = 8.2, 2 H, CH-Ar), 7.28-7.37 (m, 5 H, Cbz-CH), 7.40 (d, ³J_{H,H} = 8.5, 2 H, CH-Ar). – **¹³C-NMR** (75 MHz, CDCl₃): δ = 17.1 (+, 1 C, CH₃), 19.3 (+, 1 C, CH₃), 28.3 (+, 3 C, CH₃), 29.4 (+, 1 C, CH₃), 36.4 (-, 1 C, CH₂), 39.7 (-, 1 C, CH₂), 40.4 (-, 1 C, CH₂), 59.6 (+, 1 C, CH), 66.6 (-, 1 C, CH₂), 67.2 (-, 1 C, CH₂), 68.9 (C_{quat}, 1 C, NH-C), 81.4 (C_{quat}, 1 C, CO-tBu), 83.6 (+, 1 C, O-CH), 122.4 (C_{quat}, 1 C, C-Br), 127.5-128.4 (+, 7 C, CH-Ar), 131.5 (+, 2 C, CH-Ar), 135.8 (C_{quat}, 1 C, C-Ar), 136.6 (C_{quat}, 1 C, C-Ar), 155.3 (C_{quat}, 1 C, O-CO), 156.7 (C_{quat}, 1 C, O-CO), 170.9 (C_{quat}, 1 C, CONH), 171.1 (C_{quat}, 1 C, CONH). – **MS** (ES, DCM/MeOH + 10 mmol/l NH₄OAc): *m/z* (%) = 661.2 (100) [MH⁺], 678.3 (34) [MNH₄⁺]. – **HR-MS** (PI-LSIMS, CH₂Cl₂/NBA): [MH⁺] calcd. for C₃₁H₄₂BrN₄O₇ 661.2237; found 661.2245. – **IR** (neat) [cm⁻¹]: $\tilde{\nu}$ = 3353, 3236, 2943, 2841, 2531, 2362, 2340, 1668, 1518, 1453, 1259, 1226, 1117, 994, 828, 686. – **MF** C₃₁H₄₁BrN₄O₇. – **MW** 661.48.

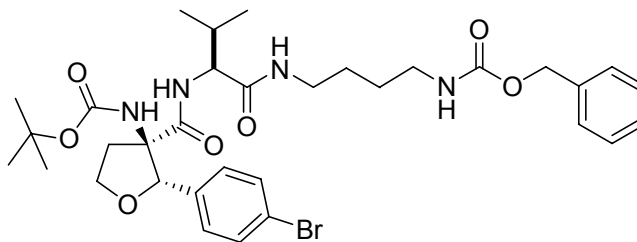

tert-Butyl (2S,3R)-3-((S)-1-(2-(benzyloxycarbonooxylamino)butylamino)-3-methyl-1-oxobutan-2-yl carbamoyl)-2-(4-bromophenyl)-tetrahydrofuran-3-yl carbamate (**237**):

Under an atmosphere of nitrogen compound **181** (400 mg, 0.82 mmol, 1 eq.) was dissolved in 4.9 ml DMF (6 ml/mmol) and cooled to 0 °C in an ice bath. To the solution DIPEA (423 μ l, 2.47 mmol, 3 eq.), HOAt (169 mg, 1.24 mmol, 1.5 eq.) and HATU (470 mg, 1.24 mmol, 1.5 eq.) were added in this sequence. Then benzyl aminobutyl carbamate **235** (256 mg, 1.15 mmol, 1.4 eq.) was slowly added in portions. The mixture was allowed to warm to room temperature and stirred for 24 hours. The reaction was quenched with 12 ml of water and 4 ml of 1M aqueous KHSO₄ and extracted with diethyl ether (3x18 ml). The combined organic layers were washed twice with brine. Afterwards the solution was dried over MgSO₄ and concentrated under reduced pressure. The crude product was then purified by column chromatography on flash silica gel (EE:PE 40:60; R_f = 0.17) to give the product as colorless solid in 60 % yield (340 mg, 0.49 mmol).

MP 104-105 °C. – **¹H-NMR** (300 MHz, CDCl₃): δ = 0.52-0.67 (m, 6 H, Val-CH₃), 1.31-1.48 (m, 12 H, Boc-CH₃, CH, CH₂), 1.58-1.72 (m, 1 H, CH), 1.33-2.52 (m, 1 H, CH₂), 2.59-2.78 (m, 1 H, CH₂), 3.06-3.18 (m, 5 H, CH₂), 3.55-3.71 (m, 1 H, CH₂), 3.99-4.10 (m, 1 H, CH), 4.27 (dt, ³J_{H,H} = 3.1, ³J_{H,H} = 8.6, 1 H, CH₂), 4.97 (s, 1 H, CH), 5.00 (s, 2 H, CH₂), 7.08 (d, ³J_{H,H} = 8.5, 2 H, CH-Ar), 7.11 (d, ³J_{H,H} = 8.5, 2 H, CH-Ar), 7.12-7.36 (m, 5 H, CH-Ar). – **¹³C-NMR** (75 MHz, CDCl₃): δ = 16.4 (+, 1 C, CH₃), 16.5 (+, 1 C, CH₃), 23.8 (-, 1 C, CH₂), 24.7 (-, 1 C, CH₂), 25.8 (+, 3 C, CH₃), 29.0 (+, 1 C, CH), 33.9 (-, 1 C, CH₂), 36.4 (-, 1 C, CH₂), 37.9 (-, 1 C, CH₂), 55.8 (+, 1 C, CH), 64.0 (-, 1 C, CH₂), 64.8 (-, 1 C, CH₂), 66.8 (C_{quat}, 1 C, NH-C), 78.5 (C_{quat}, 1 C, CO-tBu), 81.0 (+, 1 C, O-CH), 119.6 (C_{quat}, 1 C, C-Br), 125.2-126.0 (+, 7 C, CH-Ar), 128.8 (+, 2 C, CH-Ar), 128.8 (C_{quat}, 1 C, C-Ar), 134.0 (C_{quat}, 1 C, C-Ar), 152.1 (C_{quat}, 1 C, O-CO), 154.3 (C_{quat}, 1 C, O-CO), 167.9 (C_{quat}, 1 C, CONH), 168.4 (C_{quat}, 1 C, CONH). – **MS** (ES, DCM/MeOH + 10 mmol/l NH₄OAc): *m/z* (%) = 589.2 (66) [MH⁺ - Boc], 632.1 (14) [MH⁺ - C₄H₈], 689.3 (100) [MH⁺]. – **HR-MS** (PI-LSIMS, CH₂Cl₂/NBA): [MH⁺] calcd. for C₃₃H₄₆BrN₄O₇ 689.2550; found 689.2547. – **IR** (neat) [cm⁻¹]: $\tilde{\nu}$ = 3292, 2974, 2931, 2876, 2362, 2332, 1638, 1522, 1366, 1251, 1160, 1071, 1011, 846. – **MF** C₃₁H₄₁BrN₄O₇. – **MW** 661.48.

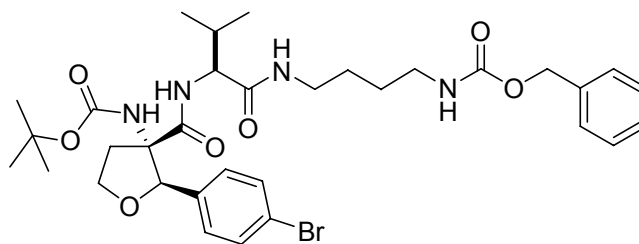

tert-Butyl (2R,3S)-3-((S)-1-(2-(benzyloxycarbonooxylamino)butylamino)-3-methyl-1-oxobutan-2-ylcarbamoyl)-2-(4-bromophenyl)-tetrahydrofuran-3-ylcarbamate (239):

Under an atmosphere of nitrogen compound **183** (320 mg, 0.66 mmol, 1 eq.) was dissolved in 4.0 ml DMF (6 ml/mmol) and cooled to 0 °C in an ice bath. To the solution DIPEA (339 μ l, 1.98 mmol, 3 eq.), HOAt (136 mg, 0.99 mmol, 1.5 eq.) and HATU (376 mg, 0.99 mmol, 1.5 eq.) were added in this sequence. Then benzyl aminobutylcarbamate **235** (205 mg, 0.92 mmol, 1.4 eq.) was slowly added in portions. The mixture was allowed to warm to room temperature and stirred for 24 hours. The reaction was quenched with 8 ml of water and 3 ml of 1M aqueous KHSO₄ and extracted with diethyl ether (3x12 ml). The combined organic layers were washed twice with brine. Afterwards the solution was dried over MgSO₄ and concentrated under reduced pressure. The crude product was then purified by column chromatography on flash silica gel (EE:PE 40:60; R_f = 0.20) to give the product as colorless solid in 56 % yield (253 mg, 0.37 mmol).

MP 86-87 °C. – **¹H-NMR** (300 MHz, CDCl₃): δ = 0.62 (d, ³J_{H,H} = 6.9, 3 H, Val-CH₃), 0.66 (d, ³J_{H,H} = 6.8, 3 H, Val-CH₃), 1.32-1.49 (m, 12 H, Boc-CH₃, CH₂), 1.80-1.94 (m, 1 H, CH), 2.11-2.31 (m, 1 H, CH₂), 2.90-3.01 (m, 2 H, CH₂), 3.02-3.11 (m, 2 H, CH₂), 3.12-3.24 (m, 1 H, CH₂), 3.48-3.60 (m, 1 H, CH₂), 3.92-4.06 (m, 1 H, CH), 4.21-4.31 (m, 2 H, CH₂), 4.85 (s, 1 H, CH), 4.95 (s, 2 H, CH₂), 6.29 (s, 1 H, NH), 7.14 (d, ³J_{H,H} = 8.4, 1 H, CH-Ar), 7.23-7.28 (m, 5 H, CH-Ar), 7.33 (d, ³J_{H,H} = 8.4, 2 H, CH-Ar). – **¹³C-NMR** (75 MHz, CDCl₃): δ = 20.2 (+, 2 C, CH₃), 27.6 (-, 1 C, CH₂), 28.1 (-, 1 C, CH₂), 29.5 (+, 3 C, CH₃), 31.1 (+, 1 C, CH), 38.1 (-, 1 C, CH₂), 40.3 (-, 1 C, CH₂), 41.8 (-, 1 C, CH₂), 60.6 (+, 1 C, CH), 67.8 (-, 1 C, CH₂), 68.9 (-, 1 C, CH₂), 71.2 (C_{quat}, 1 C, NH-C), 82.5 (C_{quat}, 1 C, CO-tBu), 86.2 (+, 1 C, O-CH), 123.5 (C_{quat}, 1 C, C-Br), 129.2-130.2 (+, 7 C, CH-Ar), 132.5 (+, 2 C, CH-Ar), 137.3 (C_{quat}, 1 C, C-Ar), 138.1 (C_{quat}, 1 C, C-Ar), 156.5 (C_{quat}, 1 C, O-CO), 158.6 (C_{quat}, 1 C, O-CO), 172.3 (C_{quat}, 1 C, CONH), 172.6 (C_{quat}, 1 C, CONH). – **MS** (ES, DCM/MeOH + 10 mmol/l NH₄OAc): *m/z* (%) = 589.2 (37) [MH⁺ - Boc], 632.1 (14) [MH⁺ - C₄H₈], 689.3 (100) [MH⁺], 711.3 (21) [MNa⁺]. – **HR-MS** (PI-LSIMS, CH₂Cl₂/NBA): [MH⁺] calcd. for C₃₃H₄₆BrN₄O₇ 689.2550; found 689.2537. – **IR** (neat) [cm⁻¹]: $\tilde{\nu}$ = 3349, 2970, 2931, 2361, 2342, 1668, 1519, 1455, 1260, 1118, 1075, 1011, 995, 830. – **MF** C₃₁H₄₁BrN₄O₇. – **MW** 661.48.

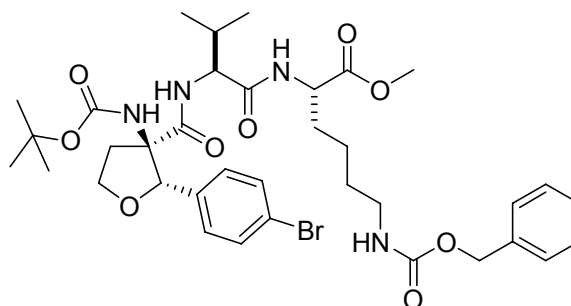

Methyl 6-(benzyloxycarbonylamino)-2-((S)-2-((2S,3R)-2-(4-bromophenyl)-3-(tert-butoxycarbonylamino)-tetrahydrofuran-3-carboxamido)-3-methylbutanamido)hexanoate (**241**):

Under an atmosphere of nitrogen compound **181** (400 mg, 0.82 mmol, 1 eq.) was dissolved in 5.7 ml DMF (7 ml/mmol) and cooled to 0 °C in an ice bath. To the solution DIPEA (423 μ l, 2.47 mmol, 3 eq.), HOAt (169 mg, 1.24 mmol, 1.5 eq.) and HATU (470 mg, 1.24 mmol, 1.5 eq.) were added in this sequence. Then H-Lys(Cbz)-OMe **240** (364 mg, 1.24 mmol, 1.5 eq.) was slowly added in portions. The mixture was allowed to warm to room temperature and stirred for 24 hours. The reaction was quenched with 14 ml of water and 4 ml of 1M aqueous KHSO_4 and extracted with diethyl ether (3x21 ml). The combined organic layers were washed twice with brine. Afterwards the solution was dried over MgSO_4 and concentrated under reduced pressure. The crude product was then purified by column chromatography on flash silica gel (EE:PE 40:60; R_f = 0.23) to give the product as colorless solid in 59 % yield (370 mg, 0.49 mmol).

MP 74-75 °C. – **$^1\text{H-NMR}$** (300 MHz, CDCl_3): δ = 0.58 (t, $^3J_{\text{H,H}}$ = 7.1, 6 H, Val- CH_3), 1.27-1.54 (m, 13 H, Boc- CH_3 , CH_2), 1.62-1.87 (m, 3 H, CH, CH_2), 2.47-2.82 (m, 2 H, CH_2), 3.03-3.28 (m, 2 H, CH_2), 3.69 (s, 3 H, OCH_3), 3.98-4.06 (m, 1 H, CH), 4.16-4.46 (m, 3 H, CH, CH_2), 5.01-5.15 (m, 3 H, CH, CH_2), 5.31 (bs, 1 H, NH), 6.13 (bs, 1 H, NH), 6.54 (d, $^3J_{\text{H,H}}$ = 6.9, 1 H, NH), 6.63 (d, $^3J_{\text{H,H}}$ = 8.2, 1 H, NH), 7.20 (d, $^3J_{\text{H,H}}$ = 8.2, 2 H, CH-Ar), 7.28-7.37 (m, 7 H, CH-Ar). – **$^{13}\text{C-NMR}$** (75 MHz, CDCl_3): δ = 17.4 (+, 1 C, Val- CH_3), 18.7 (+, 1 C, Val- CH_3), 22.1 (-, 1 C, CH_2), 28.4 (+, 3 C, Boc- CH_3), 29.5 (-, 1 C, CH_2), 30.9 (-, 1 C, CH_2), 31.6 (+, 1 C, CH), 35.7 (-, 1 C, CH_2), 39.8 (-, 1 C, CH_2), 52.3 (+, 1 C, CH_3), 58.2 (+, 2 C, CH), 66.7 (-, 1 C, CH_2), 67.9 (C_{quat} , 1 C, NH-C), 80.2 (C_{quat} , 1 C, Boc-C), 81.0 (+, 1 C, CH), 121.5 (C_{quat} , 1 C, C-Br), 127.0-128.5 (+, 7 C, Ar-CH), 131.2 (+, 2 C, Ar-CH), 136.5 (C_{quat} , 2 C, C-Ar), 154.2 (C_{quat} , 1 C, O-CO), 156.9 (C_{quat} , 1 C, O-CO), 171.0 (C_{quat} , 1 C, CONH), 172.4 (C_{quat} , 1 C, CONH). – **MS** (ES, DCM/MeOH + 10 mmol/l NH_4OAc): m/z (%) = 761.3 (43) [MH^+], 778.4 (100) [MNH_4^+]. – **HR-MS** (PI-LSIMS, MeOH/ CH_2Cl_2 /NBA): [MH^+] calcd. for $\text{C}_{36}\text{H}_{50}\text{BrN}_4\text{O}_9$ 761.2761; found 761.2753. – **IR** (neat) [cm^{-1}]: $\tilde{\nu}$ = 3352, 3237, 2941, 2841, 2529, 2362, 2342, 1668, 1517, 1453, 1259, 1226, 1117, 993, 828, 686. – **MF** $\text{C}_{36}\text{H}_{49}\text{BrN}_4\text{O}_9$. – **MW** 761.7.

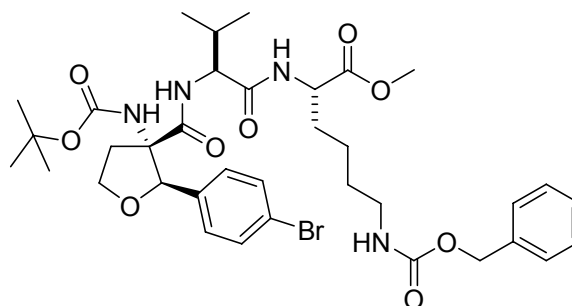

Methyl 6-(benzyloxycarbonylamino)-2-((S)-2-((2R,3S)-2-(4-bromophenyl)-3-(tert-butoxycarbonylamino)-tetrahydrofuran-3-carboxamido)-3-methylbutanamido)hexanoate (242):

Under an atmosphere of nitrogen compound **183** (400 mg, 0.82 mmol, 1 eq.) was dissolved in 5.7 ml DMF (7 ml/mmol) and cooled to 0 °C in an ice bath. To the solution DIPEA (423 μ l, 2.47 mmol, 3 eq.), HOAt (169 mg, 1.24 mmol, 1.5 eq.) and HATU (470 mg, 1.24 mmol, 1.5 eq.) were added in this sequence. Then H-Lys(Cbz)-OMe **240** (364 mg, 1.24 mmol, 1.5 eq.) was slowly added in portions. The mixture was allowed to warm to room temperature and stirred for 24 hours. The reaction was quenched with 14 ml of water and 4 ml of 1M aqueous KHSO₄ and extracted with diethyl ether (3x21 ml). The combined organic layers were washed twice with brine. Afterwards the solution was dried over MgSO₄ and concentrated under reduced pressure. The crude product was then purified by column chromatography on flash silica gel (EE:PE 40:60; R_f = 0.20) to give the product as colorless solid in 63 % yield (392 mg, 0.51 mmol).

MP 80-81 °C. – **¹H-NMR** (300 MHz, CDCl₃): δ = 0.80 (t, ³J_{H,H} = 6.9, 3 H, Val-CH₃), 0.83 (t, ³J_{H,H} = 6.9, 3 H, Val-CH₃), 1.29-1.56 (m, 13 H, Boc-CH₃, CH₂), 1.45-1.59 (m, 2 H, CH₂), 1.96-2.05 (m, 1 H, CH), 2.55-2.85 (m, 2 H, CH₂), 3.05-3.32 (m, 2 H, CH₂), 3.70 (s, 3 H, OCH₃), 3.89 (t, ³J_{H,H} = 6.2, 1 H, CH), 4.20-4.39 (m, 3 H, CH, CH₂), 4.94 (d, ³J_{H,H} = 12.3, 1 H, CH₂), 5.00 (t, ³J_{H,H} = 6.2, 1 H, CH), 5.10 (d, ³J_{H,H} = 12.3, 1 H, CH₂), 5.24 (bs, 1 H, NH), 6.11 (bs, 1 H, NH), 6.47 (d, ³J_{H,H} = 6.9, 1 H, NH), 6.74 (d, ³J_{H,H} = 7.4, 1 H, NH), 7.16 (d, ³J_{H,H} = 8.5, 2 H, CH-Ar), 7.28-7.37 (m, 7 H, CH-Ar). – **¹³C-NMR** (75 MHz, CDCl₃): δ = 17.8 (+, 1 C, Val-CH₃), 18.9 (+, 1 C, Val-CH₃), 22.3 (-, 1 C, CH₂), 28.4 (+, 3 C, Boc-CH₃), 29.6 (-, 1 C, CH₂), 30.7 (-, 1 C, CH₂), 31.5 (+, 1 C, CH), 36.1 (-, 1 C, CH₂), 39.8 (-, 1 C, CH₂), 52.3 (+, 1 C, CH₃), 58.2 (+, 2 C, CH), 66.7 (-, 1 C, CH₂), 67.9 (C_{quat}, 1 C, NH-C), 80.4 (C_{quat}, 1 C, Boc-C), 81.8 (+, 1 C, CH), 121.6 (C_{quat}, 1 C, C-Br), 127.2-128.5 (+, 7 C, Ar-CH), 131.0 (+, 1 C, Ar-CH), 131.3 (+, 1 C, Ar-CH), 135.6 (C_{quat}, 1 C, C-Ar), 136.5 (C_{quat}, 1 C, C-Ar), 154.4 (C_{quat}, 1 C, O-CO), 156.9 (C_{quat}, 1 C, O-CO), 171.1 (C_{quat}, 1 C, CONH), 171.1 (C_{quat}, 1 C, CONH). – **MS** (ES, DCM/MeOH + 10 mmol/l NH₄OAc): *m/z* (%) = 761.2 (100) [MH⁺], 778.3 (61) [MNH₄⁺]. – **HR-MS** (PI-LSIMS, CH₂Cl₂/NBA): [MH⁺] calcd. for C₃₆H₅₀BrN₄O₉ 761.2761; found 761.2759. – **IR** (neat) [cm⁻¹]: $\tilde{\nu}$ = 3352, 3236, 2941, 2841,

2536, 2367, 2341, 1667, 1517, 1453, 1259, 1226, 1117, 994, 828, 685. – **MF**
 $C_{36}H_{49}BrN_4O_9$. – **MW** 761.7.

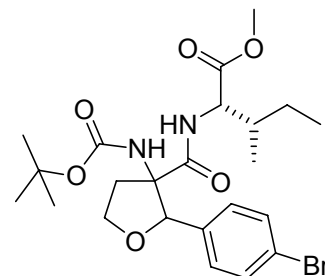

(2S,3S)-Methyl 2-(2-(4-bromophenyl)-3-(tert-butoxycarbonylamino)-tetrahydrofuran-3-carboxamido)-3-methylpentanoate (244 / 245):

Under an atmosphere of nitrogen compound *rac*-**138** (490 mg, 1.27 mmol, 1 eq.) was dissolved in DMF (5 ml) and cooled to 0 °C in an ice bath. To the solution DIPEA (652 μ l, 3.81 mmol, 3 eq.), HOBt (259 mg, 1.90 mmol, 1.5 eq.) and EDC (337 μ l, 1.90 mmol, 1.5 eq.) were added in this sequence. Then H-Ile-OMe*HCl **243** (323 mg, 1.78 mmol, 1.4 eq.) was slowly added in portions. The mixture was allowed to warm to room temperature and stirred for 24 hours. The reaction was quenched with 4 ml of water and 3 ml of 1M aqueous $KHSO_4$ and extracted with diethyl ether (3x5 ml). The combined organic layers were washed twice with brine. Afterwards the solution was dried over $MgSO_4$ and concentrated under reduced pressure. The crude product was then purified by column chromatography on flash silica gel (PE:diethyl ether 70:30) to give the product as two diastereomers as colorless solids with an overall yield of 71 % (460 mg, 0.89 mmol).

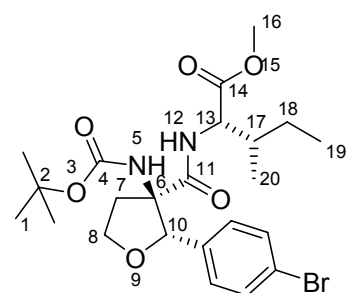

244:

MP 102-104 °C. – **1H -NMR** (300 MHz, $CDCl_3$): δ = 0.47 (d, $^3J_{H,H}$ = 6.8, 3 H, 20), 0.69-0.87 (m, 4 H, 18 + 19), 0.99-1.15 (m, 1 H, 18), 1.39-1.55 (m, 10 H, 1 + 17), 2.50-2.67 (m, 1 H, 7), 2.73-2.87 (m, 1 H, 7), 3.68 (s, 3 H, 16), 4.18-4.37 (m, 3 H, 8 + 12), 5.41 (bs, 1 H, 10), 6.19 (bs, 1 H, NH), 6.47 (d, $^3J_{H,H}$ = 8.2, 1 H, NH), 7.23 (d, $^3J_{H,H}$ = 8.3, 2 H, CH-Ar), 7.40 (d, $^3J_{H,H}$ = 8.5, 2 H, CH-Ar). – **^{13}C -NMR** (75 MHz, $CDCl_3$): δ = 11.4 (+, 1 C, 19), 14.9 (+, 1 C, 20), 24.6 (-, 1 C, 18), 28.4 (+, 3 C, 1), 36.1 (-, 1 C, 7), 37.7 (+, 1 C, 17), 52.1 (+, 1 C, 16),

56.7 (+, 1 C, 13), 66.6 (-, 1 C, 8), 67.5 (C_{quat} , 1 C, 6), 80.2 (C_{quat} , 1 C, 2), 80.3 (+, 1 C, 10), 121.5 (C_{quat} , 1 C, C-Br), 127.0 (+, 2 C, CH-Ar), 131.3 (+, 2 C, CH-Ar), 136.4 (C_{quat} , 1 C, C-Ar), 154.2 (C_{quat} , 1 C, 4), 171.1 (C_{quat} , 1 C, 11), 172.1 (C_{quat} , 1 C, 14). – **MS** (Cl, NH_3): m/z (%) = 513.1 (100) [MH^+], 530.1 (38) [MNH_4^+]. – **Elemental analysis** calcd. (%) for $\text{C}_{23}\text{H}_{33}\text{BrN}_2\text{O}_6$ (513.4): C 53.89, H 6.98, N 5.46; found: C 53.76, H 6.89, N 5.08. – **IR** (neat) [cm^{-1}]: $\tilde{\nu}$ = 3441, 3289, 2971, 2930, 2864, 2364, 1739, 1712, 1659, 1501, 1362, 1269, 1230, 1164, 1081, 995, 802. – **MF** $\text{C}_{23}\text{H}_{33}\text{BrN}_2\text{O}_6$. – **MW** 513.42.

X-Ray structure and crystal data of **244**:

Orthorhombic; space group: P 21 21 21; cell dimensions: $a = 6.1856(12)$ Å, $\alpha = 95^\circ$, $b = 19.460(2)$ Å, $\beta = 90^\circ$, $c = 20.895(2)$ Å, $\gamma = 940^\circ$; $V = 2515.2(6)$ Å³; $Z = 4$, $D_x = 1.356$ Mg/m³; $\mu = 1.673$ mm⁻¹; $F(000) = 1072$. Data collection: $T = 296$ K; graphite monochromator. A translucent colorless crystal with dimensions of 0.220 x 0.160 x 0.040 mm was used to measure 18493 reflections (4700 unique reflections, $R_{\text{int}} = 0.1215$) from 1.95° to 25.84° on a STOE-IPDS diffractometer with the rotation method. Structure refinement: The F^2 value was refined using the full-matrix least squares refinement method, with a goodness-of-fit O_f of 0.666 for all reflections and 295 parameters.

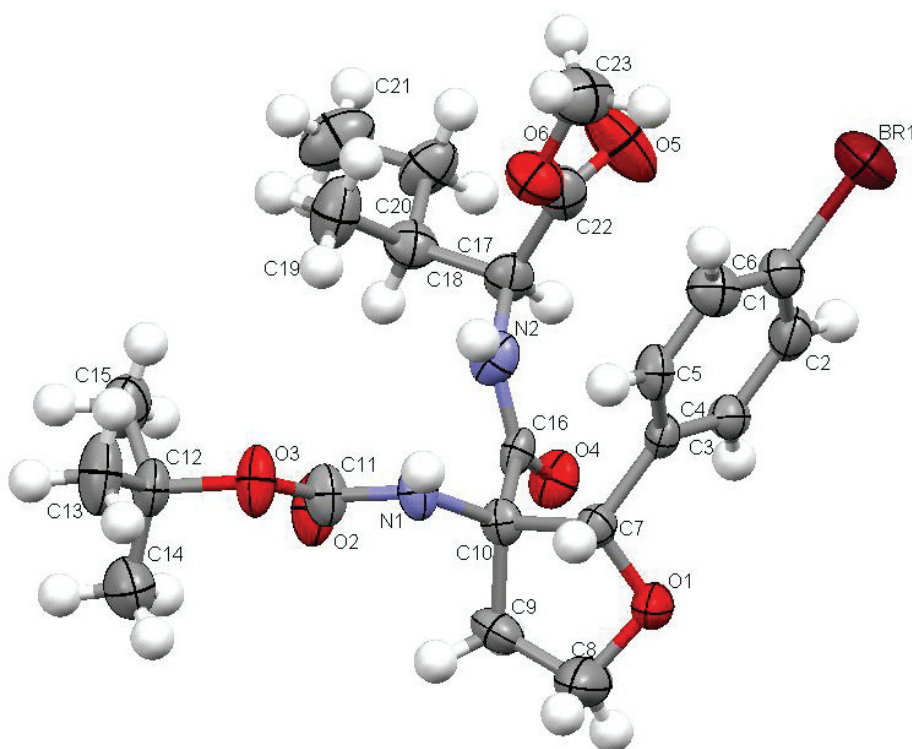

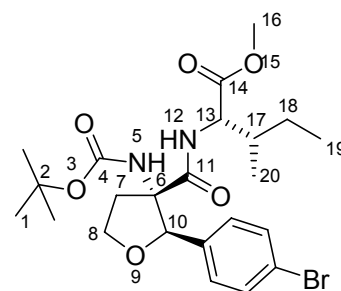
**245:**

MP 112-114 °C. – **¹H-NMR** (300 MHz, CDCl₃): δ = 0.73 (d, ³J_{H,H} = 5.5, 3 H, 20), 0.85 (t, ³J_{H,H} = 7.4, 3 H, 19), 1.07-1.13 (m, 1 H, 18), 1.22-1.39 (m, 1 H, 18), 1.47 (s, 9 H, 1), 1.54-1.69 (m, 1 H, 17), 2.42-2.65 (m, 1 H, 7), 2.73-2.92 (m, 1 H, 7), 3.61 (s, 3 H, 16), 4.14 (dd, ³J_{H,H} = 4.9, ³J_{H,H} = 7.7, 12), 4.23-4.37 (m, 2 H, 8 + 12), 5.35 (bs, 1 H, 10), 6.13 (s, 1 H, NH), 6.71 (bs, 1 H, NH), 7.19 (d, ³J_{H,H} = 8.5, 2 H, CH-Ar), 7.37 (d, ³J_{H,H} = 8.5, 2 H, CH-Ar). – **¹³C-NMR** (75 MHz, CDCl₃): δ = 11.5 (+, 1 C, 19), 15.2 (+, 1 C, 20), 25.3 (-, 1 C, 18), 28.3 (+, 3 C, 1), 36.2 (-, 1 C, 7), 38.3 (+, 1 C, 17), 51.9 (+, 1 C, 16), 56.4 (+, 1 C, 13), 66.6 (-, 1 C, 8), 67.7 (C_{quat}, 1 C, 6), 80.3 (C_{quat}, 1 C, 2), 81.1 (+, 1 C, 10), 121.6 (C_{quat}, 1 C, C-Br), 127.3 (+, 2 C, CH-Ar), 131.0 (+, 2 C, CH-Ar), 135.6 (C_{quat}, 1 C, C-Ar), 154.3 (C_{quat}, 1 C, 4), 171.0 (C_{quat}, 1 C, 11), 171.3 (C_{quat}, 1 C, 14). – **MS** (Cl, NH₃): *m/z* (%) = 513.1 (100) [MH⁺], 530.1 (38) [MNH₄⁺]. – **Elemental analysis** calcd. (%) for C₂₃H₃₃BrN₂O₆ (513.4): C 53.89, H 6.48, N 5.46; found: C 53.66, H 6.52, N 5.17. – **IR** (neat) [cm⁻¹]: $\tilde{\nu}$ = 3439, 3316, 2964, 2927, 2861, 2369, 2332, 1693, 1641, 1518, 1483, 1364, 1253, 1162, 1091, 1012, 834. – **MF** C₂₃H₃₃BrN₂O₆. – **MW** 513.42.

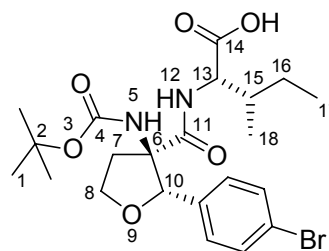

(2S,3S)-2-((2S,3R)-2-(4-Bromophenyl)-3-(tert-butoxycarbonylamino)-tetrahydrofuran-3-carboxamido)-3-methylpentanoic acid (**246**):

Compound **244** (250 mg, 0.49 mmol) was dissolved in 5 ml of a MeCN:water mixture (4:1). To the solution 2M aqueous LiOH (270 μ l, 0.54 mmol) was added drop by drop. The mixture was stirred over night. After acidification with sat. aqueous NH_4Cl solution the mixture was extracted with DCM (3x5 ml). The combined organic layers were dried over MgSO_4 and concentrated under reduced pressure to give the product as colorless solid 86 % yield. (210 mg, 0.42 mmol)

MP 95-97 $^\circ\text{C}$. – **$^1\text{H-NMR}$** (300 MHz, CDCl_3): δ = 0.51 (d, $^3J_{\text{H,H}}$ = 6.6, 3 H, 18), 0.72-0.94 (m, 4 H, 16 + 17), 1.09-1.22 (m, 1 H, 18), 1.47 (s, 9 H, 1), 1.51-1.62 (m, 1 H, 15), 2.49-2.66 (m, 1 H, 7), 2.75-2.90 (m, 1 H, 7), 4.22-4.39 (m, 3 H, 8 + 13), 5.46 (bs, 1 H, 10), 6.22 (bs, 1 H, NH), 6.47 (d, $^3J_{\text{H,H}}$ = 7.4, 1 H, NH), 7.21-7.28 (m, 2 H, CH-Ar), 7.41 (d, $^3J_{\text{H,H}}$ = 8.5, 2 H, CH-Ar). – **$^{13}\text{C-NMR}$** (75 MHz, CDCl_3): δ = 11.5 (+, 1 C, 17), 14.9 (+, 1 C, 18), 25.6 (-, 1 C, 16), 28.4 (+, 3 C, 1), 36.1 (-, 1 C, 7), 37.5 (+, 1 C, 15), 56.6 (+, 1 C, 13), 67.4 (C_{quat} , 1 C, 6), 67.9 (-, 1 C, 8), 80.1 (C_{quat} , 1 C, 10), 80.3 (+, 1 C, 2), 121.6 (C_{quat} , 1 C, C-Br), 126.9 (+, 2 C, CH-Ar), 131.4 (+, 2 C, CH-Ar), 136.4 (C_{quat} , 1 C, C-Ar), 154.2 (C_{quat} , 1 C, 4), 171.2 (C_{quat} , 1 C, 11), 175.9 (C_{quat} , 1 C, 14). – **MS** (Cl, NH_3): m/z (%) = 443.1 (6) [$\text{MH}^+ - \text{C}_4\text{H}_8$], 499.2 (100) [MH^+], 516.2 (17) [MNH_4^+]. – **IR** (neat) [cm^{-1}]: $\tilde{\nu}$ = 3428, 3269, 2965, 2361, 1717, 1652, 1507, 1366, 1255, 1162, 1087, 1011, 795. – **MF** $\text{C}_{22}\text{H}_{31}\text{BrN}_2\text{O}_6$. – **MW** 499.40.

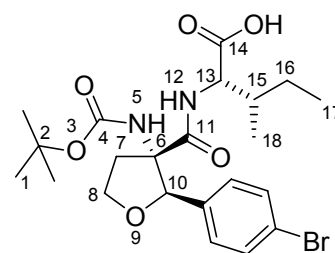

(2S,3S)-2-((2R,3S)-2-(4-Bromophenyl)-3-(tert-butoxycarbonylamino)-tetrahydrofuran-3-carboxamido)-3-methylpentanoic acid (247):

Compound **245** (200 mg, 0.39 mmol) was dissolved in 4 ml of a MeCN:water mixture (4:1). To the solution 2M aqueous LiOH (214 μ l, 0.43 mmol) was added drop by drop. The mixture was stirred over night. After acidification with sat. aqueous NH_4Cl solution the mixture was extracted with DCM (3x4 ml). The combined organic layers were dried over MgSO_4 and concentrated under reduced pressure to give the product as colorless solid 97 % yield. (189 mg, 0.38 mmol)

MP 177-178 $^\circ\text{C}$. – **$^1\text{H-NMR}$** (300 MHz, CDCl_3): δ = 0.70-1.17 (m, 3 H, 18), 0.89 (t, $^3J_{\text{H,H}}$ = 7.3, 3 H, 17), 1.02-1.17 (m, 1 H, 16), 1.31-1.40 (m, 1 H, 16), 1.48 (s, 9 H, 1), 1.61-1.76 (m, 1 H, 15), 2.48-2.68 (m, 1 H, 7), 2.71-2.90 (m, 1 H, 7), 4.16-4.24 (m, 1H, 8), 4.26-4.41 (m, 2 H, 8 + 13), 5.35 (bs, 1 H, 10), 6.08 (bs, 1 H, NH), 6.75 (bs, 1 H, NH), 7.22 (d, $^3J_{\text{H,H}}$ = 8.2, 2 H, CH-Ar), 7.39 (d, $^3J_{\text{H,H}}$ = 8.5, 2 H, CH-Ar). – **$^{13}\text{C-NMR}$** (75 MHz, CDCl_3): δ = 11.6 (+, 1 C, 17), 15.3 (+, 1 C, 18), 25.6 (-, 1 C, 16), 28.4 (+, 3 C, 1), 36.3 (-, 1 C, 7), 38.1 (+, 1 C, 15), 56.4 (+, 1 C, 13), 66.6 (C_{quat} , 1 C, 6), 67.9 (-, 1 C, 8), 80.4 (C_{quat} , 1 C, 10), 81.4 (+, 1 C, 2), 127.4 (C_{quat} , 1 C, C-Br), 131.2 (+, 2 C, CH-Ar), 135.5 (+, 2 C, CH-Ar), 145.4 (C_{quat} , 1 C, C-Ar), 154.5 (C_{quat} , 1 C, 4), 171.1 (C_{quat} , 1 C, 11), 175.4 (C_{quat} , 1 C, 14). – **MS** (Cl, NH_3): m/z (%) = 443.1 (6) [$\text{MH}^+ - \text{C}_4\text{H}_8$], 499.2 (100) [MH^+], 516.2 (17) [MNH_4^+]. – **IR** (neat) [cm^{-1}]: $\tilde{\nu}$ = 3428, 3269, 2969, 2359, 1717, 1652, 1506, 1365, 1253, 1162, 1086, 1011, 866. – **MF** $\text{C}_{22}\text{H}_{31}\text{BrN}_2\text{O}_6$. – **MW** 499.40.

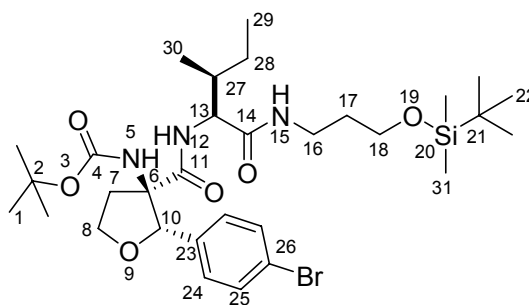

tert-Butyl (2S,3R)-2-(4-bromophenyl)-3-((2S,3S)-1-(3-(tert-butyldimethylsilyloxy)propylamino)-3-methyl-1-oxopentan-2-ylcarbamoyl)-tetrahydrofuran-3-ylcarbamate (**249**):

Under an atmosphere of nitrogen compound **246** (1.00 g, 2.00 mmol, 1 eq.) was dissolved in DMF (10 ml) and cooled to 0 °C in an ice bath. To the solution DIPEA (1.03 ml, 6.01 mmol, 3 eq.), HOAt (613 mg, 4.51 mmol, 2.25 eq.) and TBTU (1.45 g, 4.51 mmol, 2.25 eq.) were added in this sequence. Then 3-(tert-butyldimethylsilyloxy)propan-1-amine **248** (569 mg, 3.00 mmol, 1.5 eq.) was slowly added in portions. The mixture was allowed to warm to room temperature and stirred for 24 hours. The reaction was quenched with 10 ml of water and extracted with diethyl ether (3x15 ml). The combined organic layers were washed twice with brine. Afterwards the solution was dried over MgSO₄ and concentrated under reduced pressure. The crude product was then purified by column chromatography on flash silica gel (PE:diethyl ether 70:30, R_f = 0.25) to give the product as colorless solid in 71 % yield (460 mg, 0.89 mmol).

MP 115-117 °C. – ¹H-NMR (300 MHz, CDCl₃): δ = 0.00 (s, 6 H, 31), 0.52 (d, ³J_{H,H} = 6.6, 3 H, 30), 0.64 (d, ³J_{H,H} = 4.4, 3 H, 29), 0.75-0.99 (m, 11 H, 22 + 28), 1.30-1.46 (m, 10 H, 1 + 27), 1.64 (quintet, ³J_{H,H} = 6.0, 2 H, 17), 2.42-2.60 (m, 1 H, 7), 2.62-2.76 (m, 1 H, 7), 3.15-3.40 (m, 2 H, 16), 3.66 (t, ³J_{H,H} = 5.6, 2 H, 18), 3.80 (dd, ³J_{H,H} = 6.6, ³J_{H,H} = 8.2, 1 H, 13), 4.19 (q, ³J_{H,H} = 8.3, 1 H, 8), 4.30 (dt, ³J_{H,H} = 3.5, ³J_{H,H} = 8.7, 1 H, 8), 5.26 (bs, 1 H, 10), 6.08 (bs, 1 H, 15), 6.19 (bs, 1 H, 5), 6.58 (d, ³J_{H,H} = 8.5, 1 H, 12), 7.18 (d, ³J_{H,H} = 8.2, 2 H, CH-Ar), 7.33 (d, ³J_{H,H} = 8.5, 2 H, CH-Ar). – ¹³C-NMR (75 MHz, CDCl₃): δ = -6.5 (+, 2 C, 31), 10.2 (+, 1 C, 29), 14.0 (+, 1 C, 29), 17.2 (C_{quat}, 1 C, 21), 23.4 (-, 1 C, 28), 24.9 (+, 3 C, 22), 27.4 (+, 3 C, 1), 30.5 (-, 1 C, 17), 34.8 (-, 1 C, 7), 36.9 (+, 1 C, 27), 37.2 (-, 1 C, 16), 57.1 (+, 1 C, 13), 61.3 (-, 1 C, 18), 65.7 (-, 1 C, 8), 66.9 (C_{quat}, 1 C, 6), 79.1 (C_{quat}, 1 C, 2), 80.3 (+, 1 C, 10), 120.5 (C_{quat}, 1 C, 16), 126.2 (+, 2 C, CH-Ar), 130.2 (+, 2 C, CH-Ar), 135.6 (C_{quat}, 1 C, 23), 153.2 (C_{quat}, 1 C, 4), 169.2 (C_{quat}, 1 C, 14), 169.7 (C_{quat}, 1 C, 11). – **MS** (ES, DCM/MeOH + 10 mmol/l NH₄OAc): *m/z* (%) = 572.3 (7) [MH⁺ - Boc], 616.3 (61) [MH⁺ - C₄H₈], 672.3 (100) [MH⁺], 596.3 (70) [M - H⁺ - ^tBuOH], 670.3 (98) [M - H⁺], 706.4 (17) [M + Cl], 730.4 (18) [M + CH₃COO⁻]. – **Elemental analysis** calcd. (%) for C₂₃H₃₃BrN₂O₆·H₂O (670.8): C 54.13, H 7.92, N 6.11; found: C 54.36, H 7.98, N 6.11. – **IR**

(neat) [cm⁻¹]: $\tilde{\nu}$ = 3340, 3319, 2968, 2932, 2883, 2956, 2369, 1693, 1640, 1481, 1363, 1253, 1162, 1089, 1012, 833. – **MF** C₃₁H₅₂BrN₃O₆Si. – **MW** 670.75.

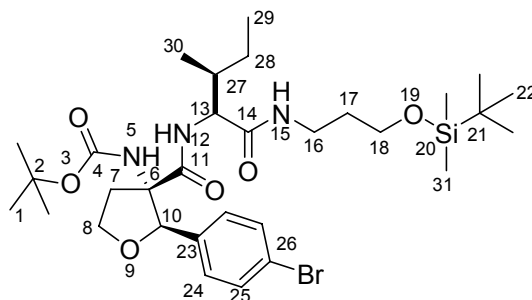

tert-Butyl (2R,3S)-2-(4-bromophenyl)-3-((2S,3S)-1-(3-(tert-butyldimethylsilyloxy)propyl-amino)-3-methyl-1-oxopentan-2-ylcarbamoyl)-tetrahydrofuran-3-ylcarbamate (250):

Under an atmosphere of nitrogen compound **247** (300 mg, 0.60 mmol, 1 eq.) was dissolved in DMF (4 ml) and cooled to 0 °C in an ice bath. To the solution DIPEA (309 μ l, 1.80 mmol, 3 eq.), HOAt (184 mg, 1.35 mmol, 2.25 eq.) and TBTU (434 mg, 1.35 mmol, 2.25 eq.) were added in this sequence. Then 3-(tert-butyldimethylsilyloxy)propan-1-amine **248** (171 mg, 0.90 mmol, 1.5 eq.) was slowly added in portions. The mixture was allowed to warm to room temperature and stirred for 24 hours. The reaction was quenched with 5 ml of water and extracted with diethyl ether (3x10 ml). The combined organic layers were washed twice with brine. Afterwards the solution was dried over MgSO₄ and concentrated under reduced pressure. The crude product was then purified by column chromatography on flash silica gel (PE:diethyl ether 70:30, R_f = 0.25) to give the product as colorless solid in 62 % yield (250 mg, 0.37 mmol).

MP 154-155 °C. – **¹H-NMR** (300 MHz, CDCl₃): δ = 0.05 (s, 6 H, 31), 0.75 (d, ³J_{H,H} = 6.9, 3 H, 30), 0.79-1.03 (m, 14 H, 22 + 28 + 29), 1.43-1.51 (m, 10 H, 1 + 27), 1.65-1.83 (m, 2 H, 17), 2.50-2.64 (m, 1 H, 7), 2.73-2.86 (m, 1 H, 7), 3.06-3.20 (m, 1 H, 16), 3.24-3.36 (m, 1 H, 16), 3.66 (t, ³J_{H,H} = 5.9, 2 H, 18), 3.70-3.78 (m, 1 H, 13), 4.22-4.40 (m, 2 H, 8), 5.27 (bs, 1 H, 10), 5.92 (t, ³J_{H,H} = 4.8, 1 H, 15), 6.13 (bs, 1 H, 5), 6.51 (d, ³J_{H,H} = 8.0, 1 H, 12), 7.19 (d, ³J_{H,H} = 8.2, 2 H, CH-Ar), 7.39 (d, ³J_{H,H} = 8.5, 2 H, CH-Ar). – **¹³C-NMR** (75 MHz, CDCl₃): δ = -6.4 (+, 2 C, 31), 10.4 (+, 1 C, 29), 14.5 (+, 1 C, 30), 17.2 (C_{quat}, 1 C, 21), 23.8 (-, 1 C, 28), 24.9 (+, 3 C, 22), 27.4 (+, 3 C, 1), 30.7 (-, 1 C, 17), 35.2 (-, 1 C, 7), 36.3 (+, 1 C, 27), 36.7 (-, 1 C, 16), 57.1 (+, 1 C, 13), 60.9 (-, 1 C, 18), 65.7 (-, 1 C, 8), 66.7 (C_{quat}, 1 C, 6), 79.4 (C_{quat}, 1 C, 2), 80.4 (+, 1 C, 10), 120.6 (C_{quat}, 1 C, 26), 127.0 (+, 2 C, CH-Ar), 131.3 (+, 2 C, CH-Ar), 134.6 (C_{quat}, 1 C, 23), 153.4 (C_{quat}, 1 C, 4), 168.5 (C_{quat}, 1 C, 14), 170.0 (C_{quat}, 1 C, 11). – **MS** (ES, DCM/MeOH + 10 mmol/l NH₄OAc): *m/z* (%) = 572.3 (7) [MH⁺ - Boc], 616.3 (61) [MH⁺ - C₄H₈], 672.3 (100) [MH⁺], 596.3 (70) [M - H⁺ - ^tBuOH], 670.3 (98) [M - H⁺], 706.4 (17) [M + Cl⁻], 730.4 (18) [M + CH₃COO⁻]. – **Elemental analysis** calcd. (%)

for $C_{23}H_{33}BrN_2O_6$ (670.8): C 55.51, H 7.81, N 6.26; found: C 55.33, H 7.84, N 5.79. – IR (neat) [cm^{-1}]: $\tilde{\nu}$ = 2958, 2933, 2858, 2360, 2330, 1716, 1641, 1513, 1367, 1252, 1163, 1103, 1072, 1010, 835. – MF $C_{31}H_{52}BrN_3O_6Si$. – MW 670.75.

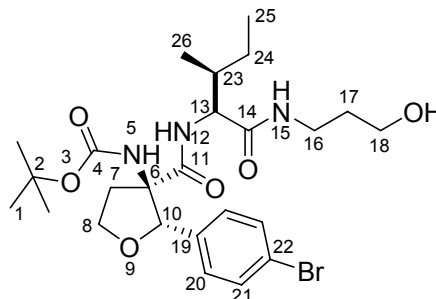

tert-Butyl (2S,3R)-2-(4-bromophenyl)-3-((3S)-1-(3-hydroxypropylamino)-3-methyl-1-oxo-pentan-2-ylcarbamoyl)-tetrahydrofuran-3-ylcarbamate (199):

Under a nitrogen atmosphere compound **249** (650 mg, 0.91 mmol, 1 eq.) was dissolved in 9 ml of dry acetonitrile (10 ml/mmol) and cooled to 0 °C in an ice bath. To the solution glacial acetic acid (332 μ l, 6.81 mmol, 6 eq.) and 1M TBAF in THF (2.91 ml, 2.91 mmol, 3 eq.) were added in this sequence. The mixture was allowed to slowly warm to room temperature and was stirred for 12 hours. The solvent was evaporated under reduced pressure. The crude product was then purified by column chromatography on flash silica gel (PE:diethyl ether 75:25, R_f (EE) = 0.57.) to give the product colorless solid with a yield of 82 % (440 mg, 0.79 mmol).

MP 119-121 °C. – **1H -NMR** (400 MHz, COSY, $CDCl_3$): 0.61 (d, $^3J_{H,H}$ = 6.8, 3 H, 26), 0.67-0.75 (m, 4 H, 24 + 25), 1.00-1.12 (m, 1 H, 24), 1.39-1.53 (m, 10 H, 1 + 23), 1.65 (quintet, $^3J_{H,H}$ = 5.9, 2 H, 17), 2.50-2.71 (m, 2 H, 7), 3.23-3.42 (m, 2 H, 16), 3.59 (t, $^3J_{H,H}$ = 5.7, 2 H, 18), 3.87 (dd, $^3J_{H,H}$ = 6.9, $^3J_{H,H}$ = 8.2, 1 H, 13), 4.19 (q, $^3J_{H,H}$ = 8.3, 1 H, 8), 4.33 (dt, $^3J_{H,H}$ = 3.5, $^3J_{H,H}$ = 8.5, 1 H, 8), 5.24 (bs, 1 H, 10), 6.03 (bs, 1 H, 5), 6.50 (t, $^3J_{H,H}$ = 5.6, 1 H, 15), 6.67 (d, $^3J_{H,H}$ = 8.5, 1 H, 12), 7.19 (d, $^3J_{H,H}$ = 8.4, 2 H, 20), 7.37 (d, $^3J_{H,H}$ = 8.5, 2 H, 21). – **^{13}C -NMR** (100 MHz, HSQC, HMBC, $CDCl_3$): δ = 11.2 (+, 1 C, 25), 15.0 (+, 1 C, 26), 24.4 (-, 1 C, 24), 28.3 (+, 3 C, 1), 31.9 (-, 1 C, 17), 35.4 (-, 1 C, 7), 36.5 (-, 1 C, 16), 37.3 (+, 1 C, 23), 58.2 (+, 1 C, 13), 59.6 (-, 1 C, 18), 66.8 (-, 1 C, 8), 68.5 (C_{quat} , 1 C, 6), 80.5 (C_{quat} , 1 C, 2), 82.3 (+, 1 C, 10), 121.8 (C_{quat} , 1 C, 22), 127.4 (+, 2 C, 20), 131.2 (+, 2 C, 21), 136.6 (C_{quat} , 1 C, 19), 154.4 (C_{quat} , 1 C, 4), 170.8 (C_{quat} , 1 C, 11), 171.4 (C_{quat} , 1 C, 14). – **MS** (ES, DCM/MeOH + 10 mmol/l NH_4OAc): m/z (%) = 500.1 (9) [MH^+ - C_4H_8], 558.2 (100) [MH^+]. – IR (neat) [cm^{-1}]: $\tilde{\nu}$ = 3292, 2970, 2931, 2879, 2359, 2340, 1714, 1645, 1488, 1366, 1253, 1161, 1069, 1010, 849, 583. – MF $C_{25}H_{38}BrN_3O_6$. – MW 556.49.

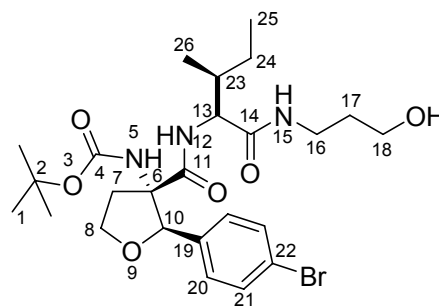

tert-Butyl (2R,3S)-2-(4-bromophenyl)-3-((2S,3S)-1-(3-hydroxypropylamino)-3-methyl-1-oxopentan-2-ylcarbamoyl)-tetrahydrofuran-3-ylcarbamate (251):

Under a nitrogen atmosphere compound **250** (340 mg, 0.51 mmol, 1 eq.) was dissolved in 5 ml of dry acetonitrile (10 ml/mmol) and cooled to 0 °C in an ice bath. To the solution glacial acetic acid (174 μ l, 3.04 mmol, 6 eq.) and 1M TBAF in THF (1.52 ml, 1.52 mmol, 3 eq.) were added in this sequence. The mixture was allowed to slowly warm to room temperature and was stirred for 12 hours. The solvent was evaporated under reduced pressure. The product was obtained after column chromatography on flash silica gel (EtOAc, R_f = 0.55) as colorless solid in 70 % yield (200 mg, 0.36 mmol).

MP 119-121 °C. – **¹H-NMR** (300 MHz, CDCl₃): 0.74 (d, ³J_{H,H} = 6.9, 3 H, 26), 0.82-1.01 (m, 5 H, 24 + 25), 1.44-1.68 (m, 11 H, 1 + 17 + 23), 1.67-1.94 (m, 1 H, 17), 2.69 (t, ³J_{H,H} = 7.3, 2 H, 7), 2.98-3.12 (m, 1 H, 16), 3.25-3.38 (m, 1 H, 16), 3.52 (t, ³J_{H,H} = 5.6, 2 H, 18), 3.88 (dd, ³J_{H,H} = 4.9, ³J_{H,H} = 7.5, 1 H, 13), 4.21-4.39 (m, 2 H, 8), 5.23 (bs, 1 H, 10), 5.79 (t, ³J_{H,H} = 4.8, 15), 6.05 (bs, 1 H, 5), 6.34 (d, ³J_{H,H} = 7.1, 1 H, 12), 7.24 (d, ³J_{H,H} = 8.2, 2 H, CH-Ar), 7.46 (d, ³J_{H,H} = 8.5, 2 H, CH-Ar). – **¹³C-NMR** (75 MHz, CDCl₃): δ = 10.6 (+, 1 C, 25), 14.8 (+, 1 C, 26), 23.6 (-, 1 C, 24), 27.3 (+, 3 C, 1), 31.1 (-, 1 C, 17), 34.8 (-, 1 C, 7), 35.3 (+, 1 C, 23), 35.5 (-, 1 C, 16), 57.6 (+, 1 C, 13), 57.7 (-, 1 C, 18), 65.9 (-, 1 C, 8), 67.2 (C_{quat}, 1 C, 6), 79.9 (C_{quat}, 1 C, 2), 81.1 (+, 1 C, 10), 121.1 (C_{quat}, 1 C, 22), 126.2 (+, 2 C, CH-Ar), 130.5 (+, 2 C, CH-Ar), 134.9 (C_{quat}, 1 C, 19), 153.8 (C_{quat}, 1 C, 4), 170.1 (C_{quat}, 1 C, 11/14), 170.3 (C_{quat}, 1 C, 11/14). – **MS** (ES, DCM/MeOH + 10 mmol/l NH₄OAc): m/z (%) = 458.3 (7) [MH⁺ - Boc], 500.3 (55) [MH⁺ - C₄H₈], 558.3 (100) [MH⁺]. – **IR** (neat) [cm⁻¹]: $\tilde{\nu}$ = 3251, 2968, 2932, 2871, 2357, 2341, 1718, 1643, 1487, 1366, 1252, 1165, 1071, 1011, 850, 581. – **MF** C₂₅H₃₈BrN₃O₆. – **MW** 556.49.

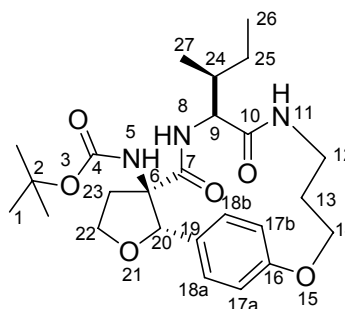
**Compound 198:**

Compound **197** (100 mg, 0.18 mmol, 1 eq.), CsCO₃ (52 mg, 0.27 mmol, 1.5 eq.), Pd(OAc)₂ (4 mg, 0.02 mmol, 0.1 eq.) and dicyclohexyl(2',4',6'-triisopropylbiphenyl-2-yl)phosphine (11 mg, 0.02 mmol, 1.25 eq.) were put into an oven dried Schlenk tube. The reaction vessel was evacuated and back filled with argon twice. To the mixture 7.2 ml of dry toluene (40 ml/mmol) were added and the tube was closed with a glass stopper and sealed. The mixture was heated under stirring to 80 °C for 24 h. The mixture was filtered and washed with 10 ml of ethyl acetate twice. The organic layers were concentrated under reduced pressure. The crude product was then purified by column chromatography on flash silica gel using a solvent gradient starting from diethyl ether:ethanol 98:2 and going to 95:5 (EtOAc, R_f = 0.20). In a second purification step the compound was submitted to HPLC using a phenomenex Luna C18 and a acetonitril/H₂O (0.0059 % TFA) gradient (5%-98% acetonitril) to give the product as colorless solid (34 mg, 0.07 mmol, 40 %).

MP 146-147 °C. - **¹H-NMR** (600 MHz, COSY, NOESY, CDCl₃): 0.72 (d, ³J_{H,H} = 6.6, 3 H, 27), 0.81 (t, 3 H, ³J_{H,H} = 6.9, 26), 0.87-0.97 (m, 1 H, 25a), 1.35-1.42 (m, 1 H, 25b), 1.45 (s, 9 H, 1), 1.53-1.60 (m, 1 H, 24), 1.68 (bs, 1 H, 13a), 2.09 (ddd, ³J_{H,H} = 4.8, ³J_{H,H} = 8.0, ²J_{H,H} = 13.1, 1 H, 13b), 2.41-2.55 (m, 1 H, 23b), 2.93 (ddd, ³J_{H,H} = 3.3, ³J_{H,H} = 7.2, ²J_{H,H} = 10.4, 1 H, 12a), 3.34 (s, 1 H, 23a), 3.41 (s, 1 H, 9), 3.70-3.77 (m, 1 H, 12b), 4.01 (q, ³J_{H,H} = 7.8, 1 H, 22), 4.22 (dt, ³J_{H,H} = 3.3, ²J_{H,H} = 11.6, 1 H, 14a), 4.41 (dt, ³J_{H,H} = 4.6, ³J_{H,H} = 8.3, 1 H, 22a/b), 4.47 (dt, ³J_{H,H} = 12.2, ²J_{H,H} = 3.8, 1 H, 14b), 4.55 (s, 1 H, 20), 5.03-5.19 (m, 2 H, 5 + 11), 6.22 (d, ³J_{H,H} = 7.5, 1 H, 8), 6.82 (dd, ³J_{H,H} = 8.3, ⁴J_{H,H} = 2.5, 1 H, 17a), 6.86 (dd, ³J_{H,H} = 8.6, ⁴J_{H,H} = 2.4, 1 H, 17b), 7.04 (s, 1 H, 18b), 7.37 (dd, ³J_{H,H} = 8.6, ⁴J_{H,H} = 2.0, 1 H, 17a). - **¹³C-NMR** (150 MHz, HSQC, HMBC, CDCl₃): δ = 11.5 (+, 1 C, 26), 14.4 (+, 1 C, 27), 25.1 (-, 1 C, 25), 26.7 (-, 1 C, 13), 28.2 (+, 3 C, 1), 36.8 (-, 1 C, 23), 37.6 (-, 1 C, 12), 38.7 (+, 1 C, 24), 58.7 (+, 1 C, 9), 67.2 (-, 1 C, 14), 68.6 (-, 1 C, 22), 71.2 (C_{quat}, 1 C, 6), 81.2 (C_{quat}, 1 C, 2), 89.5 (+, 1 C, 20), 114.3 (+, 1 C, 17a), 117.5 (+, 1 C, 17b), 127.0 (+, 1 C, 18b), 127.7 (+, 1 C, 18a), 129.2 (C_{quat}, 1 C, 19), 154.6 (C_{quat}, 1 C, 4), 159.2 (C_{quat}, 1 C, 16), 169.8 (C_{quat}, 1 C, 10), 170.2 (C_{quat}, 1 C, 7). - **MS** (ES, DCM/MeOH + 10 mmol/l NH₄OAc): *m/z* (%) = 458.3 (7) [MH⁺ - Boc], 500.3 (55) [MH⁺ - C₄H₈], 558.3 (100) [MH⁺]. - **HR-MS** (FAB,

MeOH/glycerol): [M] calcd. for C₂₅H₃₇N₃O₆ 475.2684; found 475.2682. – **MF** C₂₅H₃₇N₃O₆.
– **MW** 475.58.

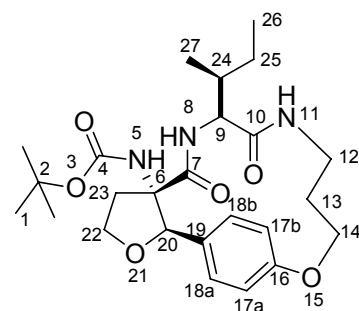

Compound 252:

Compound **251** (80 mg, 0.14 mmol, 1 eq.), CsCO₃ (42 mg, 0.22 mmol, 1.5 eq.), Pd(OAc)₂ (3 mg, 0.01 mmol, 0.1 eq.) and dicyclohexyl(2',4',6'-triisopropylbiphenyl-2-yl)phosphine (9 mg, 0.02 mmol, 1.25 eq.) were put into an oven dried Schlenk tube. The reaction vessel was evacuated and back filled with argon twice. To the mixture 5.6 ml of dry toluene (40 ml/mmol) were added and the tube was closed with a glass stopper and sealed. The mixture was heated under stirring to 80 °C for 24 h. The mixture was filtered and washed with 10 ml of ethyl acetate twice. The organic layers were concentrated under reduced pressure. The crude product was then purified by column chromatography on flash silica gel using a solvent gradient starting from diethyl ether:ethanol 98:2 and going to 95:5 (EtOAc, R_f = 0.20). In a second purification step the compound was submitted to HPLC using a phenomenex Luna C18 and a acetonitril/H₂O (0.0059 % TFA) gradient (5%-98% acetonitril) to give the product as colorless solid (12.4 mg, 0.03 mmol, 19 %).

MP 159-160 °C. - **¹H-NMR** (400 MHz, COSY, NOESY, CDCl₃): 0.77 (d, ³J_{H,H} = 6.7, 3 H, 27), 0.83 (t, 3 H, ³J_{H,H} = 7.3, 26), 0.90-1.03 (m, 1 H, 25a), 1.30-1.39 (m, 1 H, 25b), 1.46 (s, 9 H, 1), 1.68-1.82 (m, 2 H, 13a + 24), 2.10-2.24 (m, 1 H, 13b), 2.31 (dt, ²J_{H,H} = 12.8, ³J_{H,H} = 9.4, 1 H, 23b), 2.67-2.80 (m, 1 H, 23a), 2.90 (ddd, ²J_{H,H} = 10.7, ³J_{H,H} = 7.5, ³J_{H,H} = 3.5, 1 H, 12a), 3.58 (t, ³J_{H,H} = 7.5, 1 H, 9), 3.64-3.75 (m, 1 H, 12b), 4.22 (ddd, ²J_{H,H} = 12.7, ³J_{H,H} = 9.1, ³J_{H,H} = 3.6, 1 H, 14a), 4.29-4.37 (m, 2 H, 22a/b), 4.42 (dt, ²J_{H,H} = 12.8, ³J_{H,H} = 4.9, 1 H, 14b), 4.73 (s, 1 H, 11), 5.29 (s, 1 H, 20), 5.77 (d, ³J_{H,H} = 7.8, 8), 6.02 (s, 1 H, 5), 6.86 (dd, ³J_{H,H} = 8.4, ⁴J_{H,H} = 2.6, 1 H, 17a), 6.97 (dd, ³J_{H,H} = 8.6, ⁴J_{H,H} = 2.6, 1 H, 17a), 7.12 (dd, ³J_{H,H} = 8.6, ⁴J_{H,H} = 2.1, 1 H, 18a), 7.39 (dd, ³J_{H,H} = 8.5, ⁴J_{H,H} = 1.8, 1 H, 18b). - **¹³C-NMR** (100 MHz, HSQC, HMBC, CDCl₃): δ = 11.3 (+, 1 C, 26), 15.5 (+, 1 C, 27), 24.6 (-, 1 C, 25), 28.2 (-, 1 C, 13), 28.3 (+, 3 C, 1), 35.1 (-, 1 C, 23), 37.3 (-, 1 C, 12), 37.7 (+, 1 C, 24), 59.2 (+, 1 C, 9), 67.6 (-, 1 C, 22), 68.6 (-, 1 C, 14), 70.2 (C_{quat}, 1 C, 6), 80.1 (C_{quat}, 1 C, 2), 83.2 (+, 1 C, 20), 117.1 (+, 1 C, 17b), 117.6 (+, 1 C, 17a), 126.0 (+, 1 C, 18a), 126.4 (+, 1 C,

18b), 131.7 (C_{quat}, 1 C, 19), 154.6 (C_{quat}, 1 C, 4), 158.6 (C_{quat}, 1 C, 16), 170.2 (C_{quat}, 1 C, 10), 171.5 (C_{quat}, 1 C, 7). - **MS** (ES, DCM/MeOH + 10 mmol/l NH₄OAc): *m/z* (%) = 420.2 (42) [MH⁺ - C₄H₈], 476.2 (25) [MH⁺], 493.4 (100) [MNH₄⁺], 951.6 (21) [2M + H⁺]. - **HR-MS** (FAB, MeOH/glycerol): [MH⁺] calcd. for C₂₅H₃₈N₃O₆ 476.2761; found 476.2758. - **MF** C₂₅H₃₇N₃O₆. - **MW** 475.58.

C. Abbreviations

A	anion
abs.	absolute
aq	aqueous
Bn	benzyl
Boc	<i>tert</i> -butoxycarbonyl
BPA	bis(pyridin-2-ylmethyl)amine
Bzl	benzyl
calc	calculated
Cbz	benzoyloxycarbonyl
CD	circular dichroism
CFP	cyan fluorescent protein
COSY	correlated spin spectroscopy
cyclen	1,4,7,10-tetraazacyclododecane
d	day
DCC	dicyclohexyl carbodiimide
DCM	dichloromethane
DIPEA	ethyl diisopropyl amine
DMAP	4-(dimethylamino) pyridine
DMF	dimethylformamide
DMSO	dimethyl sulfoxide
DNA	deoxyribonucleic acid
DPA	dipicolylamine
ED	ethylene diamine
EDC	1-ethyl-3-(3-dimethylaminopropyl)carbodiimide
EE	ethyl acetate
EI	electron impact
ESI	electron spray ionization
Et	ethyl
EtOAc	ethyl acetate
EtOH	ethanol
FAB	fast atom bombardment
Fmoc	fluorenylmethoxycarbonyl
FRET	fluorescence resonance energy transfer
GFP	green fluorescent protein

GP	general procedure
h	hour
HATU	2-(1H-7-azabenzotriazol-1-yl)-1,1,3,3-tetramethyl uronium hexafluorophosphate methanaminium
HBTU	O-benzotriazole-N,N,N',N'-tetramethyl-uronium-hexafluoro-phosphate
Hepes	4-(2-hydroxyethyl)-piperazine-1-ethane sulfonic acid
HMBC	heteronuclear multiple-bond correlation
HOAt	1-hydroxy-7-azabenzotriazole
HOBt	1-hydroxybenzotriazole
HPLC	high performance liquid chromatography
HR-MS	high resolution mass spectroscopy
HSQC	heteronuclear single quantum coherence
IC50	half maximal inhibitory concentration
IDA	iminodiacetic acid
IMAC	immobilized metal affinity chromatography
IR	infrared spectroscopy
J	coupling constant
K	cation
LB	Langmuir-Blodgett
LC	liquid chromatography
M	molecule
M	mol/L
Me	methyl
MeCN	acetonitril
MeOH	methanol
MF	molecular formula
min	minutes
MP	melting point
MS	mass spectroscopy
MW	molecular weight
NEt3	triethyl amine
NIR	near infrared
NMA	<i>N</i> -methyl amino acid
NMR	nuclear magnetic resonance
NOE	nuclear overhauser effect
NOESY	nuclear overhauser effect spectroscopy
NTA	nitrilotriacetic acid

OAc	acetate
PE	petrol ether
PET	photoinduced electron transfer
Ph	phenyl
<i>rac</i>	racemic
R _f	retention factor
RNA	ribonucleic acid
ROESY	rotating-frame NOE spectroscopy
rt	room temperature
SAM	self-assembled monolayers
sat	saturated
SDS-PAGE	sodium dodecyl sulfate-polyacrylamide gel electrophoresis
SN	nucleophilic substitution
SPR	surface plasmon resonance
TAA	tetrahydrofuran amino acid
TBAF	tetrabutyl ammonium fluoride
TBDMS/TBS	tert-butyldimethylsilyl
TBDMSCl	tert-butyldimethylsilyl chloride
TBTU	2-(1H-benzotriazole-1-yl)-1,1,3,3-tetramethyl-uronium tetrafluoro borate
tBu	tert-butyl
tBuOH	tert-butanol
TFA	trifluoroacetic acid
THF	tetrahydrofuran
TLC	thin layer chromatography
TMS	trimethylsilyl
UV	ultraviolet
Vis	visible
YFP	yellow fluorescent protein
Z	benzoyloxycarbonyl

Amino acids

Aib	aminoisobutyric acid
Ala	alanine
Arg	arginine
Asn	asparagine
Asp	aspartic acid
Cys	cysteine
Gln	glutamine

Glu	glutamic acid
Gly	glycine
His	histidine
Ile	isoleucine
Leu	leucine
Lys	lysine
Met	methionine
Phe	phenylalanine
Pro	proline
Ser	serine
Thr	threonine
Trp	tryptophan
Tyr	tyrosine
Val	valine

D. References

- ¹ Manning, G.; Whyte, D. B.; Martinez, R.; Hunter, T.; Sudarsanam, S. *Science* **2002**, *298*, 1912–1934.
- ² Manning, G.; Plowman, G. D.; Hunter, T.; Sudarsanam, S. *Trends Biochem. Sci.* **2002**, *27*, 514–520.
- ³ Ubersax, J. A.; Ferrell Jr., J. E. *Nat. Rev. Mol. Cell Biol.* **2007**, *8*, 530–541.
- ⁴ (a) Pinna, L. A.; Ruzzene, M. *Biochim. Biophys. Acta* **1996**, *1314*, 191–225. (b) Cohen, P. *Trends Biochem. Sci.* **2000**, *25*, 596–601.
- ⁵ Kalume, D. E.; Molina, H.; Pandey, A. *Curr. Opin. Chem. Biol.* **2003**, *7*, 64–69.
- ⁶ Echols, N.; Harrison, P.; Balasubramanian, S.; Luscombe, N. M.; Bertone, P.; Zhang, Z.; Gerstein, M. *Nucleic Acids Res.* **2002**, *30*, 2515–2523.
- ⁷ (a) Hubbard, M. J.; Cohen, P. *Trends Biochem. Sci.* **1993**, *18*, 172–177. (b) Zhu, H.; Klemic, J. F.; Chang, S.; Bertone, P.; Casamayor, A.; Klemic, K. G.; Smith, D.; Gerstein, M.; Reed, M. A.; Snyder, M. *Nature Genet.* **2000**, *26*, 283–289.
- ⁸ Caenepeel, S.; Charydczak, G.; Sudarsanam, S.; Hunter, T.; Manning, G. *Proc. Natl. Acad. Sci. U.S.A.* **2004**, *101*, 11707–11712.
- ⁹ Hunter, T.; Plowman, G. D. *Trends Biochem. Sci.* **1997**, *22*, 18–22.
- ¹⁰ Kersten, B.; Agrawal, G. K.; Iwahashi, H.; Rakwal, R. *Proteomics* **2006**, *6*, 5517–5528.
- ¹¹ (a) Paradela, A.; Albar, J. P. *J. Proteome Res.* **2008**, *7*, 1809–1818. (b) Johnson, L. N.; Lewis, R. J. *Chem. Rev.* **2001**, *101*, 2209–2242. (c) Hunter, T. *Cell* **2000**, *3*, 177–186.
- ¹² Tamari, S.-I.; Hamachi, I. *Struct. Bond* **2008** *129*, 95–125.
- ¹³ (a) Pandey, A.; Fernandez, M. M.; Steen, H.; Blagoev, B.; Nielsen, M. M.; Roche, S.; Mann, M.; Lodish, H. F. *J. Biol. Chem.* **2000**, *275*, 39633–38639. (b) Pandey, A.; Podtelejnikov, A. V.; Blagoev, B.; Bustelo, X. R.; Mann, M.; Lodish, H. F. *Proc. Natl. Acad. Sci. U.S.A.* **2000**, *97*, 179–184. (c) Steen, H.; Kuster, B.; Fernandez, M. M.; Pandey, A.; Mann, M. *J. Biol. Chem.* **2002**, *277*, 1031–1039. (d) Yeung, Y. G.; Wang, Y.; Einstein, D. B.; Lee, P. S.; Stanley, E. R. *J. Biol. Chem.* **1998**, *273*, 17128–17137. (e) Machida, K.; Thompson, C. M.; Dierck, K.; Jablonowski, K.; Karkkainen, S.; Liu, B.; Zhang, H.; Nash, P. D.; Newman, D. K.; Nollau, P.; Pawson, T.; Renkema, G. H.; Saksela, K.; Schiller, M. R.; Shin, D. G.; Mayer, B. J. *Mol. Cell* **2007**, *26*, 899–915.

- ¹⁴ (a) Shults, M. D.; Imperiali, B. *J. Am. Chem. Soc.* **2003**, *125*, 14248–14249. (b) Rothman, D. M.; Shults, M. D.; Imperiali, B. *Trends Cell Biol.* **2005**, *15*, 502–510. (c) Sculimbrene, B. R.; Imperiali, B. *J. Am. Chem. Soc.* **2006**, *128*, 7346–7352.
- ¹⁵ (a) Anai, T.; Nakata, E.; Koshi, Y.; Ojida, A.; Hamachi, I. *J. Am. Chem. Soc.* **2007**, *129*, 6232–6239. (b) Kohira, T.; Honda, K.; Ojida, A.; Hamachi, I. *ChemBioChem* **2008**, *9*, 698–701.
- ¹⁶ Porath, J.; Carlsson, J.; Olsson, I.; Belfrage, G. *Nature* **1975**, *258*, 598–599.
- ¹⁷ Suen, S.-Y.; Liu, Y. C.; Chang, C.-S. *J. Chromatogr. B* **2003**, *797*, 305–319.
- ¹⁸ Gaberc-Porekar, V.; Menart, V. *J. Biochem. Biophys. Methods* **2001**, *49*, 335–360. Shepherd, R. E. *Coord. Chem. Rev.* **2003**, *247*, 159–196.
- ¹⁹ Feng, S.; Ye, M.; Zhou, H.; Jiang, X.; Zou, H.; Gong, B. *Mol. Cell. Proteomics* **2007**, *6*, 1656–1665.
- ²⁰ Ficarro, S. B.; McClelland, M. L.; Stukenberg, P. T.; Burke, D. J.; Ross, M. M.; Shabanowitz, J.; Hunt, D. F.; White, F. M. *Nat. Biotechnol.* **2002**, *20*, 301–305.
- ²¹ Ueda, E. K. M.; Gout, P. W.; Morganti, L. *J. Chromatogr. A* **2003**, *988*, 1–23.
- ²² (a) Li, X.; Gerber, S. A.; Rudner, A. D.; Beausoleil, S. A.; HAAS, W.; Villen, J.; Elias, J. E.; Gygi, S. P. *J. Proteome Res.* **2007**, *6*, 1190–1197. (b) Moser, K.; White, F. M. *J. Proteome Res.* **2006**, *5*, 98–104. (c) Garcia, B. A.; Busby, S. A.; Barber, C. M.; Shabanowitz, J.; Allis, C. D.; Hunt, D. F. *J. Proteome Res.* **2004**, *3*, 1219–1227.
- ²³ (a) Takeda, H.; Kawasaki, A.; Takahashi, M.; Yamada, A.; Koike, T. *Rapid Commun. Mass Spectrom.* **2003**, *17*, 2075–2081. (b) Hirano, K.; Matsui, H.; Tanaka, T.; Matsuura, F.; Satouchi, K.; Koike, T. *J. Biochem.* **2004**, *136*, 477–483.
- ²⁴ Kinoshita, E.; Yamada, A.; Takeda, H.; Kinoshita-Kikuta, E.; Koike, T. *J. Sep. Sci.* **2005**, *28*, 155–162.
- ²⁵ Inamori, K.; Kyo, M.; Nishiya, Y.; Inoue, Y.; Sonoda, T.; Kinoshita, E.; Koike, T.; Katayama, Y. *Anal. Chem.* **2005**, *77*, 3079–3985.
- ²⁶ Kinoshita, E.; Kinoshita-Kikuta, E.; Takiyama, K.; Koike, T. *Mol. Cell. Proteomics* **2006**, *5*, 749–757.
- ²⁷ Kinoshita-Kikuta, E.; Aoki, Y.; Kinoshita, E.; Koike, T. *Mol. Cell. Proteomics* **2007**, *6*, 356–366.
- ²⁸ Dirscherl, G.; Schwab, M.; Seufert, W.; König, B. *Inorg. Chim. Acta* **2009**, *363*, 537–542.
- ²⁹ Yamada, S.; Nakamura, H.; Kinoshita, E.; Kinoshita-Kikuta, E.; Koike, T.; Yoshitsugu, S. *Anal. Biochem.* **2007**, *360*, 160–162.
- ³⁰ Cahill, D. *J. Immunol. Meth.* **2001**, *250*, 81–91.

- ³¹ Jenkins, R.; Pennington, S. *Proteomics* **2001**, *1*, 13–29.
- ³² Lopez, M.; Pluskal, M. *J. Chromatogr. B* **2003**, *787*, 19–27.
- ³³ Cohen, C.; Chin-Dixon, E.; Joeng, S.; Nikiforov, T. *Anal. Biochem.* **1999**, *273*, 89–97.
- ³⁴ McBeath, G.; Schreiber, S. *Science* **2000**, *289*, 1760–1763.
- ³⁵ Houseman, B.; Huh, J.; Kron, S.; Marksich, M. *Nat. Biotechnol.* **2002**, *20*, 270–274.
- ³⁶ Martin, K.; Steinberg, T. H.; Cooley, L. A.; Gee, K. R.; Beechem, J. M.; Patton, W. F. *Proteomics* **2003**, *3*, 1244–1255.
- ³⁷ (a) Gryniewicz, G.; Poenie, M.; Tsien R. Y. *J. Biol. Chem.* **1985**, *260*, 3440–3450. (b) Miyawaki, A.; et al. *Nature* **1997**, *388*, 882–887. (c) Truong, K.; et al. *Nature Struct. Biol.* **2001**, *8*, 1069–1073.
- ³⁸ Oancea, E.; Teruel, M. N.; Quest, A. F. G.; Meyer, T. *J. Cell Biol.* **1998**, *140*, 485–498.
- ³⁹ (a) Adams, S. R.; Harootunian, A. T.; Buechler, Y. J.; Taylor, S. S.; Tsien R. Y. *Nature* **1991**, *349*, 694–697. (b) Zaccolo, M.; et al. *Nat. Cell Biol.* **1999**, *2*, 25–29.
- ⁴⁰ (a) Sato, M.; Hida, N.; Ozawa, T.; Umezawa, Y. *Anal. Chem.* **2000**, *72*, 5918–5924. (b) Honda, A.; et al. *Proc. Natl. Acad. Sci. U.S.A.* **2001**, *98*, 2437–2442.
- ⁴¹ Zacharias, D. A.; Baird, G. S.; Tsien R. Y. *Curr. Opin. Neurobiol.* **2000**, *10*, 416–421.
- ⁴² (a) Stryer, L. *Annu. Rev. Biochem.* **1978**, *47*, 819–849. (b) Selvin, P. R. *Nature Struct. Biol.* **2000**, *7*, 730–734.
- ⁴³ Zhang, J.; Ma, Y.; Taylor, S. S.; Tsien R. Y. *Proc. Natl. Acad. Sci. U.S.A.* **2001**, *98*, 14997–15002.
- ⁴⁴ (a) Kurokawa, K.; Mochizuki, N.; Ohba, Y.; Mizuno, H.; Miyawaki, M.; Matsuda, M. *Nat. Biotechnol.* **2002**, *20*, 287–294. (b) Ting, A. Y.; Kain, K. H.; Klemke, R. L.; Tsien R. Y. *Proc. Natl. Acad. Sci. U.S.A.* **2001**, *98*, 15003–15008.
- ⁴⁵ Sato, M.; Ozawa, T.; Inukai, K.; Asano, T.; Umezawa, Y. *Nat. Biotechnol.* **2002**, *20*, 287–294.
- ⁴⁶ (a) Ojida, A.; Mito-oka, Y.; Inoue, M. A.; Hamachi, I. *J. Am. Chem. Soc.* **2002**, *124*, 6256–6258. (b) Ojida, A.; Mito-oka, Y.; Sada, K.; Hamachi, I. *J. Am. Chem. Soc.* **2004**, *126*, 2454–2463. (c) Ojida, A.; Nonaka, H.; Miyahara, Y.; Tamaru, S. I.; Sada, K.; Hamachi, I. *Angew. Chem. Int. Ed.* **2006**, *45*, 5518–5521.
- ⁴⁷ (a) Ojida, A.; Inoue, M. A.; Mito-oka, Y.; Hamachi, I. *J. Am. Chem. Soc.* **2003**, *125*, 10184–10185. (b) Ojida, A.; Miyahara, Y.; Kohira, T.; Hamachi, I. *Biopolymers* **2004**, *76*, 177–184. (c) Ojida, A.; Kohira, T.; Hamachi, I. *J. Am. Chem. Soc.* **2004**, *33*, 1024–1025. (d) Ojida, A.; Hamachi, I. *Bull. Chem. Soc. Jpn.* **2006**, *79*, 35–46. (e) Ojida, A.;

- Inoue, M. A.; Mito-oka, Y.; Tsutsumi, H.; Sada, K.; Hamachi, I. *J. Am. Chem. Soc.* **2006**, *128*, 2052–2058.
- ⁴⁸ Spangler, C.; Schäferling, M.; Wolfbeis, O. S. *Microchim. Acta* **2008**, *161*, 1–39.
- ⁴⁹ (a) McCracken, S.; Fong, N.; Yankulov, K.; Ballantyne, S.; Pan, G.; Greenblatt, J.; Patterson, S. D.; Wickens, M.; Bentley, D. L. *Nature* **1997**, *385*, 357–361. (b) Hirose, Y.; Manley, J. L. *Nature* **1998**, *395*, 93–96. (c) Proudfoot, N. J.; Furger, A.; Dye, M. J. *Cell* **2002**, *108*, 501–512.
- ⁵⁰ (a) Maniatis, T.; Reed, R. *Nature* **2002**, *416*, 499–506. (b) Palancade, B.; Bensaude, O. *Eur. J. Biochem.* **2003**, *270*, 3859–3870. (c) Sims III, R. J.; Mandal, S. S.; Reinberg, D. *Curr. Opin. Cell Biol.* **2004**, *16*, 263–271.
- ⁵¹ (a) Cramer, P.; Bushnell, D. A.; Kronberg, R. D. *Science* **2001**, *292*, 1663–1876. (b) Armache, K. J.; Mitterweger, S.; Meinhart, A.; Cramer, P. *J. Biol. Chem.* **2005**, *280*, 7131–7134.
- ⁵² (a) Nonet, M.; Sweetser, D.; Young, R. A. *Cell* **1987**, *50*, 909–915. (b) West, M. L.; Corden, J. L. *Genetics* **1995**, *140*, 1223–1233.
- ⁵³ Meinhart, A.; Kamenski, T.; Höppner, S.; Baumli, S.; Cramer, P. *Genes Dev.* **2005**, *19*, 1401–1415.
- ⁵⁴ Meinhart, A.; Cramer, P. *Nature* **2004**, *430*, 223–226.
- ⁵⁵ (a) Zhang, J.; Corden, J. L. *J. Biol. Chem.* **1991**, *266*, 2297–2302. (b) Yuryev, A.; Corden, J. L. *Genetics* **1996**, *143*, 661–671.
- ⁵⁶ Buratowski, S. *Nature Struct. Biol.* **2003**, *10*, 679–680.
- ⁵⁷ Payne, J. M.; Dahmus, M. E. *J. Biol. Chem.* **1993**, *268*, 80–87.
- ⁵⁸ Komarnitsky, P.; Cho, E. J.; Buratowski, S. *Genes Dev.* **2000**, *14*, 2452–2460.
- ⁵⁹ Buratowski, S. *Nature Struct. Biol.* **2003**, *10*, 679–680.
- ⁶⁰ (a) Darnell Jr, J. E. *Nat. Rev. Cancer* **2002**, *2*, 740–749. (b) Schindler, C.; Levy, D. E.; Decker, T. *J. Biol. Chem.* **2007**, *282*, 20059–20063.
- ⁶¹ Lim, C. P.; Cao, X. *Molecular BioSystems* **2006**, *2*, 536–550.
- ⁶² (a) O'Shea, J. J.; Gadina, G.; Schreiber, R. D. *Cell* **2002**, *109*, S-121-S131. (b) Becker, S.; Groner, B.; Müller, C. W. *Nature* **1998**, *394*, 145–151.
- ⁶³ Berg, T. *ChemBioChem* **2008**, *9*, 2039–2044.
- ⁶⁴ Bromberg, J. *J. Clin. Invest.* **2002**, *109*, 1139–1142.
- ⁶⁵ (a) Ning, Z. Q.; Li, J.; McGiunness, M.; Arceci, R. J. *Oncogene* **2001**, *20*, 4528–4536. (b) Gao, B.; Shen, X.; Kunos, G.; Meng, Q.; Goldberg, I. D.; Rosen, E. M.; Fan, S. *FEBS Lett.* **2001**, *488*, 179–184. (c) Campbell, C. L.; Jiang, Z.; Savarese, T. M. *Am. J. Pathol.* **2001**, *158*, 25–32.

- ⁶⁶ Walenzyk, T. *PhD Thesis* University of Regensburg, **2005**.
- ⁶⁷ Kruppa, M. *PhD Thesis* University of Regensburg, **2005**.
- ⁶⁸ Kimura, E.; Aoki, S.; Koike, T.; Shiro, M. *J. Am. Chem. Soc.* **1997**, *119*, 3068-3076.
- ⁶⁹ (a) Koike, T.; Kimura, E. *J. Am. Chem. Soc.* **1991**, *113*, 8935-8941. (b) Fujioka, H.; Koike, T.; Yamada, N.; Kimura, E. *Heterocycles* **1996**, *42*, 775-787.
- ⁷⁰ Aoki, S.; Kimura, E. *Rev. Mol. Biotechnol.* **2002**, *90*, 129.
- ⁷¹ Kimura, E.; Ikeda, T.; Shionoya, M. *Pure Appl. Chem.* **1997**, *69*, 2187-2195.
- ⁷² (a) Aoki, S.; Kimura, E. *J. Am. Chem. Soc.* **2000**, *122*, 4542-4548. (b) Kikuta, E.; Aoki, S.; Kimura, E. *J. Am. Chem. Soc.* **2001**, *123*, 7911-7912.
- ⁷³ Pariya, C.; Chi, T.-Y.; Mishra, T. K.; Chung, C. S. *Inorg. Chem. Commun.* **2002**, *5*, 119-123.
- ⁷⁴ Kruppa, M.; Frank, D.; Leffler-Schuster, H.; König, B. *Inorg. Chem. Acta* **2006**, *359*, 1159-1168.
- ⁷⁵ Reichenbach-Klinke, R.; König, B. *J. Chem. Soc., Dalton Trans.* **2002**, *2*, 121-130.
- ⁷⁶ Turygin, D. S.; Subat, M.; Raitman, O. A.; Arslanov, V. V.; König, B.; Kalinina, M. A. *Angew. Chem. Int. Ed.* **2006**, *118*, 5466-5470.
- ⁷⁷ Turygin, D. S.; Subat, M.; Raitman, O. A.; Selector, S. L.; Arslanov, V. V.; König, B.; Kalinina, M. A. *Langmuir* **2007**, *23*, 2517-2524.
- ⁷⁸ Rajabalee, F. J. M. *J. Inorg. Nucl. Chem.* **1974**, *36*, 557-564.
- ⁷⁹ (a) Valle, G.; Bombi, G. G.; Corain, B.; Favarato, M.; Zatta, P. *J. Chem. Soc., Dalton Trans.* **1989**, *8*, 1513-1517. (b) Tewari, B. B. *J. Chromatogr. A* **1995**, *718*, 454-458.
- ⁸⁰ (a) Shepherd, R. E.; Hodgson, G. M.; Margerium, D. W. *Inorg. Chem.* **1971**, *10*, 989-994. (b) Dung, N. H.; Viossat, B.; Busnot, A.; González Pérez, J. M.; González Garcia, S.; Niclós Gutiérrez, J. *Inorg. Chem.* **1988**, *27*, 1227-1231. (c) Fábíán, I. *Inorg. Chem.* **1993**, *32*, 1184-1190.
- ⁸¹ (a) Jackson, N. E.; Margerum, D. W. *Inorg. Chem.* **1967**, *6*, 2038-2043. (b) Erickson, L. E.; Ho, F. F. L.; Reilley, C. N. *Inorg. Chem.* **1970**, *9*, 1148-1153.
- ⁸² (a) Budkuley, J. S.; Naik, G. K. *Thermochim. Acta* **1998**, *320*, 115-120. (b) Sharma, G.; Tandon, J. P. *J. Inorg. Nucl. Chem.* **1970**, *32*, 1273-1240.
- ⁸³ (a) Sharma, C. L.; Jain, P. K.; De, T. K. *J. Inorg. Nucl. Chem.* **1980**, *42*, 1681-1687. (b) Visser, H. G.; Leipoldt, J. G.; Purcell, W.; Mostert, D. *Polyhedron* **1994**, *13*, 1051-1055. (c) Bhattacharyya, S. K.; Banerjee, R. *Polyhedron* **1997**, *16*, 3371-3378.
- ⁸⁴ (a) Gustafson, R. L.; Martell, A. E. *J. Phys. Chem.* **1963**, *67*, 576-582. (b) Cox, D. D.; Que, L. *J. Am. Chem. Soc.* **1988**, *110*, 8085-8092.

- ⁸⁵ Wang, M. Y.; Kau, Y. Y.; Lee, M. S.; Doong, S. R.; Ho, J. Y.; Lee, L. H. *Biotechnol. Bioeng.* **2000**, *67*, 104–111.
- ⁸⁶ Kruppa, M.; König, B. *Chem. Rev.* **2006**, *106*, 3520–3560.
- ⁸⁷ Volz, J. J. *J. Chromatogr. A* **1998**, *800*, 29–37.
- ⁸⁸ Delgado, R.; Fátima Cabral, M. de; Castanheira, R.; Zhang, A.; Herrmann, R. *Polyhedron* **2002**, *21*, 2265–2276.
- ⁸⁹ Although Zn(II)-NTA complexes are known to be chelated by His-tagged proteins, these interactions are based on the chelating effect of two imidazoles occupying both remaining coordination sites. A single histidine residue is not sufficient for a binding effect.
- ⁹⁰ (a) Rabenstein, D. L.; Blakney, G. *Inorg. Chem.* **1973**, *12*, 128–132. (b) Hopgood, D.; Angelici, R. J. *J. Am. Chem. Soc.* **1968**, *90*, 2508–2513.
- ⁹¹ Hopgood, D.; Angelici, R. J. *J. Am. Chem. Soc.* **1968**, *90*, 2508–2513.
- ⁹² Oliver, J. D.; Barnett, B. L.; Strickland, L. C. *Acta Cryst. B* **1983**, *40*, 377–381.
- ⁹³ (a) Hannon, C. L.; Anslyn, E. V. *Bioorg. Chem. Front.* **1993**, *3*, 193. (b) Borders Jr., C. L.; Broadwater, J. A.; Bekeny, P. A.; Salmon, J. E.; Lee, A. S.; Eldridge, A. M.; Pett, V. B. *Protein Sci.* **1994**, *3*, 541–548.
- ⁹⁴ (a) Schug, K. A.; Lindner, W. *Chem. Rev.* **2005**, *105*, 67–114. (b) Best, M. D.; Tobey, S. L.; Anslyn, E. V. *Coord. Chem. Rev.* **2003**, *240*, 3–15. (c) Gale, P. A. *Coord. Chem. Rev.* **2003**, *240*, 191–221. (d) Schmidtchen, F. P.; Berger, M. *Chem. Rev.* **1997**, *97*, 1609–1646.
- ⁹⁵ Moet-Ner, M. *Chem. Rev.* **2005**, *105*, 213–284.
- ⁹⁶ (a) Fersht, A. R. *Trends Biochem. Sci.* **1987**, *12*, 301–304. (b) Fersht, A. R.; Shi, J. P.; Knill-Jones, J.; Lowe, D. M.; Wilkinson, A. J.; Blow, D. M.; Brick, P.; Carter, P.; Waye, M. M.; Winter, G. *Nature* **1985**, *314*, 235–238.
- ⁹⁷ (a) Schmidtchen, F. P. *Org. Lett.* **2002**, *4*, 431–434. (b) Haj-Zaroubi, M.; Mitzel, N. W.; Schmidtchen, F. P. *Angew. Chem. Int. Ed.* **2002**, *41*, 104–107. (c) Sebo, L.; Schweizer, B.; Diederich, F. *Helv. Chim. Acta* **2000**, *83*, 80–92.
- ⁹⁸ Schmuck, C. *Coord. Chem. Rev.* **2006**, *250*, 3053–3067.
- ⁹⁹ (a) Schmuck, C.; Heil, M. *ChemBioChem* **2003**, *4*, 1232–1238. (b) Schmuck, C.; Heil, M. *Org. Biomol. Chem.* **2003**, *1*, 633–636.
- ¹⁰⁰ (a) Zerovnik, E. *Eur. J. Biochem.* **2002**, *269*, 3362–3371. (b) Hardy, J.; Selkoe, D. J. *Science* **2002**, *297*, 353–356.
- ¹⁰¹ (a) Kuroda, Y.; Maeda, K.; Hanaoka, H.; Miyamoto, K.; Nakagawa, T. *J. Peptide Sci.* **2004**, *10*, 8–17. (b) Rzepecki, P.; Gallmeier, H.; Geib, N.; Cernovska, K.; König, B.;

- Schrader *J. Org. Chem.* **2004**, *69*, 5168–5178. (c) Hetényi, C.; Körtvélyesi, T.; Penke, B. *Bioorg. Med. Chem.* **2002**, *10*, 1587–1593. (d) Lowe, T. L.; Strzelec, A.; Kiessling, L. L.; Murphy, R. M. *Biochemistry* **2001**, *40*, 7882–7889.
- ¹⁰² Lam, K. S.; Lebl, M.; Krchnak, V. *Chem. Rev.* **1997**, *97*, 411–448.
- ¹⁰³ (a) Schmuck, C.; Wich, P. *Angew. Chem. Int. Ed.* **2006**, *45*, 4277–4281. (b) Schmuck, C.; Heil, M. *Chem. Eur. J.* **2006**, *12*, 1339–1348. (c) Schmuck, C.; Heil, M.; Scheiber, J.; Baumann, K. *Angew. Chem. Int. Ed.* **2005**, *44*, 7208–7212.
- ¹⁰⁴ Grauer, A. *Diploma Thesis* University of Regensburg **2005**.
- ¹⁰⁵ Turygin, D. S.; Subat, M.; Raitman, O. A.; Arslanov, V. V.; König, B.; Kalinina, M. A. *Angew. Chem. Int. Ed.* **2006**, *45*, 5340–5344.
- ¹⁰⁶ adapted from: Miller, C. T.; Weragoda, R.; Izbicka, E.; Iverson, B. L. *Bioorg. Med. Chem.* **2001**, *9*, 2015–2024.
- ¹⁰⁷ Balakrishnan, K.; Datar, A.; Oitker, R.; Chen, H.; Zuo, J.; Zang, L. *J. Am. Chem. Soc.* **2005**, *127*, 10496–10497.
- ¹⁰⁸ Langhals, H.; Krotz, O.; Polborn, K.; Mayer, P. *Angew. Chem. Int. Ed.* **2005**, *44*, 2427–2428.
- ¹⁰⁹ (a) Graser, F.; Hädicke, E. *Liebigs Ann. Chem.* **1980**, 1994–2011. (b) Graser, F.; Hädicke, E. *Liebigs Ann. Chem.* **1984**, 483–494. (c) Hädicke, E.; Graser, F. *Acta Crystallogr. C* **1986**, *42*, 189–195. (d) Hädicke, E.; Graser, F. *Acta Crystallogr. C* **1986**, *42*, 195–198. (e) Klebe, G.; Hädicke, E.; Berndt, J. *Acta Crystallogr. B* **1989**, *45*, 69–77.
- ¹¹⁰ Zugenmaier, P.; Duff, J.; Bluhm, T. L. *Cryst. Res. Technol.* **2000**, *35*, 1095–1115.
- ¹¹¹ Würthner, F.; Thalacker, C.; Diele, S.; Tschierske, C. *Chem. Eur. J.* **2001**, *7*, 2245–2253.
- ¹¹² (a) Würthner, F. *Chem. Commun.* **2004**, 1564–1579. (b) Schmidt, C. D.; Böttcher, C.; Hirsch, A. *Eur. J. Org. Chem.* **2007**, *33*, 5497–5505.
- ¹¹³ Lee, H. N.; Xu, Z.; Kim, S. K.; Swamy, K. M. K.; Kim, Y.; Kim, S. J.; Yoon, J. *J. Am. Chem. Soc.* **2007**, *129*, 3828–3829.
- ¹¹⁴ Schust, J.; Berg, T. *Anal. Biochem.* **2004**, *330*, 114–118.
- ¹¹⁵ Williams, D. H.; Westwell, M. S. *Chem. Soc. Rev.* **1998**, *27*, 57–63.
- ¹¹⁶ Kirkovits, G. J.; Shriver, J. A.; Gale, P. A.; Sessler, J. L. *J. Incl. Phenom. Macro.* **2001**, *41*, 69–75.
- ¹¹⁷ (a) Hünig, S.; Märkl, G.; Sauer, J. *Einführung in die apparativen Methoden in der Organischen Chemie*, 2nd Edition, Würzburg, Regensburg, 1994. (b) Author

- collective, *Organikum*, 17th Edition, VEB Deutscher Verlag der Wissenschaften, Berlin, 1988.
- ¹¹⁸ Subat, M.; Woinaroschy, K.; Anthofer, S.; Malterer, B.; König, B. *Inorg. Chem.* **2007**, *46*, 4336-4356.
- ¹¹⁹ Huang, L.; Quada Jr., J. C.; Lown, J. W. *Bioconjugate Chem.* **1995**, *6*, 21-33.
- ¹²⁰ Dardonville, C.; Fernandez-Fernandez, C.; Gibbons, S.-L.; Ryan, G. J.; Jagerovic, N.; Gabilondo, A. M.; Meana, J. J.; Callado, L. F. *Bioorg. Med. Chem.* **2006**, *14*, 6570-6580.
- ¹²¹ Bergeron, J. R.; McManis, J. S. *J. Org. Chem.* **1987**, *52*, 1700-1703.
- ¹²² Falbe, J.; Regitz, M. In *Römpp Chemie Lexikon: Proteine*, Hillen, E., Ed.; Georg Thieme Verlag, Stuttgart, Germany, 1995; Vol. 5, pp 3650-3657.
- ¹²³ Venkatraman, J.; Shankaramma, S. C.; Balaram, P. *Chem. Rev.* **2001**, *101*, 3131-3152.
- ¹²⁴ Voyer, N. *Top. Curr. Chem.* **1996**, *184*, 1-37.
- ¹²⁵ (a) Special Issue: "Protein Design". DeGrado, W. F.; Guest Ed. *Chem. Rev.* **2001**, *101*. (b) Voet, D; Voet, J. G.; Pratt, C. W. Biomolecules. In *Fundamentals of Biochemistry*; Harris, D., Ed.; John Wiley & Sons: New-York, 2002; pp 39-278.
- ¹²⁶ Jones, S.; Thornton, J. M. *Proc. Natl. Acad. Sci. USA* **1996**, *93*, 13-20.
- ¹²⁷ (a) Merrifield, R. B. *Federation Proc.* **1962**, *21*, 412. (b) Merrifield, R. B. *J. Am. Chem. Soc.* **1964**, *85*, 2149-2154.
- ¹²⁸ (a) Loffet, A. *Proceedings of the American Peptide Symposium* **2001**, *17*, 214-216. (b) Loffet, A. *J. Peptide Sci.* **2002**, *8*, 1-7.
- ¹²⁹ (a) Farmer, P. S.; Ariëns, E. J. *Trends Pharmacol. Sci.* **1982**, *3*, 362-365. (b) Stewart, J. M. *Trends Pharmacol. Sci.* **1982**, *3*, 300-303. (c) Hruby, V. J. *Life Sci.* **1982**, *31*, 189-199. (d) Freidinger, R. M. *Trends Pharmacol. Sci.* **1989**, *10*, 270-274.
- ¹³⁰ (a) Ramachandran, G. N.; Ramakrishnan, C. *Biophys. J.* **1965**, *5*, 909-933. (b) Ramachandran, G. N.; Sasisekaran, V. J. *Adv. Protein Chem.* **1968**, *23*, 283-437.
- ¹³¹ Veber, D. F.; Freidinger, R. M. *Trends Neurosci.* **1985**, *8*, 392-396.
- ¹³² (a) Kessler, H. *Angew. Chem. Int. Ed.* **1982**, *21*, 512-523. (b) Wüthrich, K. H.; Freiberg, B. von; Weber, C.; Wider, G.; Traber, R.; Widmer, H, B. W. *Science* **1991**, *254*, 953-954.
- ¹³³ Hirschmann, R. *Angew. Chem. Int. Ed.* **1991**, *30*, 1278-1301.
- ¹³⁴ Hruby, V. J.; Al-Obeidi, F. *Biochem. J.* **1990**, *268*, 249-262.
- ¹³⁵ Rizo, J.; Gierasch, L. M. *Annu. Rev. Biochem.* **1992**, *61*, 387-418.

- ¹³⁶ (a) DeGrado, W. F. *Adv. Protein Chem.* **1988**, *39*, 51–124. (b) Rose, G. D.; Gierasch, L. M.; Smith, J. A. *Adv. Protein Chem.* **1985**, *37*, 1–109.
- ¹³⁷ (a) Hruby, V. J.; Qiu, W.; Soloshonok, V. A. *Methods Enzymol.* **2001**, *343*, 91–123. (b) Cowell, S. M.; Lee, Y. S.; Cain, J. P.; Hruby, V. J. *Curr. Med. Chem.* **2004**, *11*, 2785–2798.
- ¹³⁸ Vagner, J.; Qu H.; Hruby, V. J. *Curr. Opin. Chem. Biol.* **2008**, *12*, 292–296.
- ¹³⁹ Jung, G.; Beck-Sickinger, A. G. *Angew. Chem. Int. Ed.* **1992**, *31*, 367–383.
- ¹⁴⁰ (a) Lam, K. S.; Salmon, S. E.; Hersh, E. M.; Hruby, V. J.; Kazmierski, W. M.; Knapp, R. J. *Nature* **1991**, *354*, 82–84. (b) Lam, K. S.; Salmon, S. E.; Hersh, E. M.; Hruby, V. J. *Nature* **1992**, *360*, 768. (c) Simon, R. J.; Kania, R. S.; Zuckermann, R. N.; Huebner, V. D.; Jewell, D. A.; Banville, S.; Ng, S.; Wang, L.; Rosenberg, S.; Marlowe, C. K.; Spellmayer, D. C.; Tan, R.; Frankel, A. D.; Santi, D. V.; Cohen, F. E.; Bartlett, P. A. *Proc. Natl. Acad. Sci. U.S.A.* **1992**, *89*, 9367–9371.
- ¹⁴¹ Gante, J. *Angew. Chem. Int. Ed.* **1994**, *33*, 1699–1720.
- ¹⁴² Toniolo, C.; Goodman, M. Introduction to the Synthesis of Peptidomimetics. In *Methods of Organic Chemistry: Synthesis of Peptides and Peptidomimetics*; Goodman, M., Ed.; Georg Thieme Verlag Stuttgart: New York, 2003; Vol. E 22 c, pp 1-2.
- ¹⁴³ (a) Hruby, V. J. *Biopolymers* **1993**, *33*, 1073–1082. (b) Hruby, V. J.; Li, G.; Haskell-Luevano, C.; Shenderovich, M. *Biopolymers* **1997**, *43*, 219–266. (c) Hruby, V. J. *Peptides: Chemistry, Structure and Biology* 1995, R. S. & Smith, Eds., ESCOM Publishers, Leiden, 1-17.
- ¹⁴⁴ Hruby, V. J.; Han, G.; Gitu, P. M. Synthesis of Side-Chain Conformationally Restricted α -Amino Acids. In *Methods of Organic Chemistry: Synthesis of Peptides and Peptidomimetics*; Goodman, M., Ed.; Georg Thieme Verlag Stuttgart: New York, 2003; Vol. E 22 c, pp 5-51.
- ¹⁴⁵ Jiao, D.; Russell, K. C.; Hruby, V. J. *Tetrahedron* **1993**, *17*, 3511–3520.
- ¹⁴⁶ Haskell-Luevano, C.; Toth, K.; Boteju, L.; Job, C.; Castrucci, A. M. D. L.; Hadley, M. E.; Hruby, V. J. *J. Med. Chem.* **1997**, *40*, 2740–2749.
- ¹⁴⁷ (a) Tourwe, D.; Mannekens, E.; Trang Nguyen Thi Diem.; Verheyden, P.; Jaspers, H.; Toth, G.; Peter, A.; Kertesz, I.; Toeroek, G.; Chung, N. N. *J. Med. Chem.* **1998**, *41*, 5167–5176. (b) Mosberg, H. I.; Omnaas, J. R.; Lomize, A.; Heyl, D. L. *J. Med. Chem.* **1994**, *37*, 4384.

- ¹⁴⁸ (a) Shimamoto, K.; Ishida, M.; Shinozaki, H.; Ohfune, Y. *J. Org. Chem.* **1991**, *56*, 4167–4176. (b) Pellicciari, R.; Natalini, B.; Marinozzi, M.; Monahan, J. B.; Snyder, J. P. *Tet. Lett.* **1990**, *31*, 139–142.
- ¹⁴⁹ (a) Corey, E. J.; Link, J. O. *J. Am. Chem. Soc.* **1992**, *114*, 1906–1908. (b) Corey, E. J.; Link, J. O.; Shao, Y. *Tet. Lett.* **1992**, *33*, 3435–3438.
- ¹⁵⁰ Ljungqvist, A.; Reng, D. M.; Bowers, C.; Hook, W. A.; Folkers, K. *Tetrahedron* **1990**, *46*, 3297–3304.
- ¹⁵¹ (a) MacArthur, M. W.; Thornton, J. M. *J. Mol. Biol.* **1991**, *218*, 397–412. (b) Reiersen, H.; Rees, A. R. *Trends Biochem. Sci.* **2001**, *26*, 679–684.
- ¹⁵² Stewart, D. E.; Sarkar, A.; Wampler, J. E. *J. Mol. Biol.* **1990**, *214*, 253–260.
- ¹⁵³ Kenner, G. W.; Sheppard, R. C. *Nature* **1958**, *181*, 48.
- ¹⁵⁴ (a) Arai, T.; Mikami, Y.; Fukushima, K.; Utsumi, T.; Yazawa, K. *J. Antibiot.* **1973**, *26*, 157–161. (b) Mori, Y.; Tsuboi, M.; Suzuki, M.; Fukushima, K.; Arai, T. *J. Antibiot.* **1982**, *35*, 543–544. (c) Isogai, A.; Suzuki, A.; Higashikawa, S.; Kuyama, S.; Tamura, S. *Agric. Biol. Chem.* **1981**, *45*, 1023–1024.
- ¹⁵⁵ Irreverre, F.; Morita, K.; Robertson, A. V.; Witkop, B. *J. Am. Chem. Soc.* **1963**, *85*, 2824–2831.
- ¹⁵⁶ (a) Hatanaka, S. I. *Phytochemistry* **1969**, *8*, 1305–1308. (b) For a detailed review see: Mauer, A. B. *J. Nat. Prod.* **1996**, *59*, 1205–1211.
- ¹⁵⁷ Thamm, P.; Musiol, H.-J.; Moroder, L. Synthesis of Peptides Containing Proline Analogues. In *Methods of Organic Chemistry: Synthesis of Peptides and Peptidomimetics*; Goodman, M., Ed.; Georg Thieme Verlag Stuttgart: New York, 2003; Vol. E 22 c, pp 52–86.
- ¹⁵⁸ Wiley, R. A.; Rich, D. H. *Med. Res. Rev.* **1993**, *13*, 327–384.
- ¹⁵⁹ Gante, J. *Angew. Chem. Int. Ed.* **1994**, *33*, 1699–1720.
- ¹⁶⁰ Gante, J. *Synthesis* **1989**, *6*, 405–413.
- ¹⁶¹ Magrath, J.; Abeles, R. H. *J. Med. Chem.* **1992**, *35*, 4279–4283.
- ¹⁶² Graybill, T. L.; Ross, M. J.; Gauvin, B. R.; Gregory, J. S.; Harris, A. L.; Ator, M. A.; Rinker, J. M.; Dolle, R. E. *Bioorg. Med. Chem. Lett.* **1992**, *2*, 1375–1380.
- ¹⁶³ Goodman, M.; Chorev, M. *Acc. Chem. Res.* **1979**, *12*, 1–7.
- ¹⁶⁴ Cushman, M.; Jurajj, J.; Moyer, M. *J. Org. Chem.* **1990**, *55*, 3186–3194.
- ¹⁶⁵ Dürr, H.; Goodman, M.; Jung, G. *Angew. Chem. Int. Ed.* **1992**, *31*, 785–787.
- ¹⁶⁶ Shemyakin, M. M.; Ovchinnikov, Y. A.; Ivanov, V. T.; Evstratov, A. V. *Nature* **1967**, *213*, 412–413.

- ¹⁶⁷ Bevan, K.; Davies, J. S.; Hall, M. J.; Hassall, C. H.; Morton, R. B.; Phillips, D. A.; Ogihara, Y.; Thomas, W. A. *Experientia* **1970**, *26*, 122–123.
- ¹⁶⁸ Chu, K. S.; Negrete, G. R.; Konopelski, J. P. *J. Org. Chem.* **1991**, *56*, 5196–5202.
- ¹⁶⁹ Jolad, S. D.; Hoffman, J. J.; Torrance, S. J.; Wiedhopf, R. M.; Cole, J. R.; Arora, S. K.; Bates, R. B.; Gargiulo, R. L.; Kriek, G. R. *J. Am. Chem. Soc.* **1977**, *99*, 8040–8044.
- ¹⁷⁰ Wen, S. J.; Yao, Z. *J. Org. Lett.* **2004**, *6*, 2721–2724.
- ¹⁷¹ Wipf, P. *Chem. Rev.* **1995**, *95*, 2115–2134.
- ¹⁷² Gilon, C.; Dechantsreiter, M. A.; Burkhart, F.; Friedler, A.; Kessler, H. Synthesis of N-Alkylated Peptides. In *Methods of Organic Chemistry: Synthesis of Peptides and Peptidomimetics*; Goodman, M., Ed.; Georg Thieme Verlag Stuttgart: New York, 2003; Vol. E 22 c, pp 215–271.
- ¹⁷³ Chatterjee, J.; Gilon, C.; Hoffman, A.; Kessler, H. *Acc. Chem. Res.* **2008**, *41*, 1331–1342.
- ¹⁷⁴ Fairlie, D. P.; Abbenante, G.; March, D. R. *Curr. Med. Chem.* **1995**, *2*, 654–686.
- ¹⁷⁵ (a) Tonelli, A. E. *Biopolymers* **1976**, *15*, 1615–1622. (b) Manavalan, P.; Momany, F. *Biopolymers* **1980**, *19*, 1943–1973.
- ¹⁷⁶ Bach, A. C.; Eyermann, C. J.; Groos, J. D.; Bower, M. J.; Harlow, R. L.; Weber, P. C.; DeGrado, W. F. *J. Am. Chem. Soc.* **1994**, *116*, 3207–3219.
- ¹⁷⁷ Rügger, A.; Kuhn, M.; Lichti, H.; Loosli, H. R.; Huguenin, R.; Quiquerez, C.; Wartburg, A. *Helv. Chim. Acta* **1976**, *59*, 1075–1092.
- ¹⁷⁸ Wenger, R. M. *Helv. Chim. Acta* **1984**, *67*, 502–525.
- ¹⁷⁹ Thern, B.; Rudolph, J.; Jung, G. *Tetrahedron Lett.* **2002**, *43*, 5013–5016.
- ¹⁸⁰ Aurelio, L.; Brownlee, R. T. C.; Hughes, A. B. *Chem. Rev.* **2004**, *104*, 5823–5846.
- ¹⁸¹ Miyoshi, M.; Sugano, H. In *Peptides 1974*; Wolman, Y.; John Wiley and Sons: New York, 1974; p 355.
- ¹⁸² Rink, H. *Tetrahedron Lett.* **1987**, *28*, 3787–3790.
- ¹⁸³ Peptoid nomenclature: the three letter code of natural amino acids is used but is preceded by N or Nh to indicate the peptoid homologue
- ¹⁸⁴ Kenner, G. W.; Sheppard, R. C. *Nature* **1958**, *181*, 48.
- ¹⁸⁵ Degenkolb, T.; Brückner, H. *Chem. Biodivers.* **2008**, *5*, 1817–1843.
- ¹⁸⁶ Degenkolb, T.; Kirschbaum, J.; Brückner, H. *Chem. Biodivers.* **2007**, *4*, 1052–1067.
- ¹⁸⁷ Ducloher, H. *Chem. Biodivers.* **2007**, *4*, 1023–1026.
- ¹⁸⁸ Vogt, H.; Bräse, S. *Org. Biomol. Chem.* **2007**, *5*, 405–430.
- ¹⁸⁹ Ohfuné, Y.; Shinada, T. *Eur. J. Org. Chem.* **2005**, *2005*, 5127–5143.
- ¹⁹⁰ Reichelt, A.; Martin, S. F. *Acc. Chem. Res.* **2006**, *39*, 433–442.

- ¹⁹¹ Li, P.; Xu, J. C. *J. Org. Chem.* **2000**, *65*, 2951–2958.
- ¹⁹² Schaffner, P.; Dard, M. M. *Cell. Mol. Life Sci.* **2003**, *60*, 119–132.
- ¹⁹³ Janetka, J. W.; Raman, P.; Stayshur, K.; Flentke, G. R.; Rich, D. H. *J. Am. Chem. Soc.* **1997**, *119*, 441–442.
- ¹⁹⁴ (a) Janetka, J. W.; Rich, D. H. *J. Am. Chem. Soc.* **1997**, *119*, 6488–6495. (b) Reddy, M. V. R.; Harper, M. K.; Faulkner, D. J. *Tetrahedron* **1998**, *54*, 10649–10656. (c) Sano, S.; Ikai, K.; Yoshikawa, K.; Nakamura, Y.; Obayashi, A. *J. Antibiotics* **1987**, *40*, 512–518.
- ¹⁹⁵ Condon, S. M.; Morize, I.; Darnbrough, S.; Burns, C. J.; Miller, B. E.; Uhl, J.; Burke, K.; Jariwala, N.; Locke, K.; Krolikowski, P. H.; Kumar, N. V.; Labaudiniere, R. F. *J. Am. Chem. Soc.* **2000**, *122*, 3007–3014.
- ¹⁹⁶ (a) Blackwell, H. E.; Grubbs, R. H. *Angew. Chem. Int. Ed.* **1998**, *37*, 3281–3284. (b) Blackwell, H. E.; Sadowsky, J. D.; Howard, R. J.; Sampson, J. N.; Chao, J. A.; Steinmetz, W. E.; O'Leary, D. J.; Grubbs, R. H. *J. Org. Chem.* **2001**, *66*, 5291–5302.
- ¹⁹⁷ Schafmeister, C. E.; Po, J.; Verdine, G. L. *J. Am. Chem. Soc.* **2000**, *122*, 5891–5892.
- ¹⁹⁸ Walensky, L. D.; Kung, A. L.; Escher, I.; Malia, T. J.; Barbuto, S.; Wright, R. D.; Wagner, G.; Verdine, G. L.; Korsmeyer, S. J. *Science* **2004**, *305*, 1466–1470.
- ¹⁹⁹ Garner, J.; Harding, M. *Org. Biomol. Chem.* **2007**, *5*, 3577–3585.
- ²⁰⁰ (a) Teschemacher, H.; Koch, G.; Brantl, V. *Biopolymers* **1997**, *43*, 99–117. (b) Meisel, H. *Biopolymers* **1997**, *43*, 119–128.
- ²⁰¹ Carpenter, K. A.; Schiller, P. W.; Schmidt, R.; Wilkes, B. C. *Int. J. Pept. Protein Res.* **1996**, *48*, 102.
- ²⁰² (a) Abbenante, G.; March, D. R.; Bergman, D. A.; Hunt, P. A.; Garnham, B.; Dancer, R. J.; Martin, J. L.; Fairlie, D. P. *J. Am. Chem. Soc.* **1995**, *117*, 10220–10226. (b) Reid, R. C.; March, D. R.; Dooley, M. J.; Bergman, D. A.; Abbenante, G.; Fairlie, D. P. *J. Am. Chem. Soc.* **1996**, *118*, 8511–8517. (c) Abell, A. D. *Lett. Pept. Sci.* **2001**, *8*, 267–272.
- ²⁰³ (a) Kohl, N. E.; Emini, E. A.; Schleif, W. A.; Davis, L. J.; Meimbach, J. C.; Dixon, R. A. F.; Scolnick, E. M.; Sigal, I. S. *Proc. Natl. Acad. Sci. U.S.A.* **1988**, *85*, 4686–4690. (b) Ashorn, P.; McQuade, T. J.; Thaisrivongs, S.; Tomaselli, A. G.; Tarpley, W. G.; Moss, B. *Proc. Natl. Acad. Sci. U.S.A.* **1990**, *87*, 7472–7476.
- ²⁰⁴ Tyndall, J. D. A.; Pfeiffer, B.; Abbenante, G.; Fairlie, D. P. *Chem. Rev.* **2005**, *105*, 793–826.
- ²⁰⁵ Kutzki, O.; Park, H. S.; Ernst, J. T.; Orner, B. P.; Yin, H.; Hamilton, A. D. *J. Am. Chem. Soc.* **2002**, *124*, 11838–11839.

- ²⁰⁶ (a) Ernst, J. T.; Becerril, J.; Park, H. S.; Yin, H.; Hamilton, A. D. *Angew. Chem. Int. Ed.* **2003**, *42*, 535–539. (b) Yin, H.; Lee, G. I.; Sedey, K. A.; Kutzki, O.; Park, H. S.; Orner, B. P.; Ernst, J. T.; Wang, H. G.; Sebti, S. M.; Hamilton, A. D. *J. Am. Chem. Soc.* **2005**, *127*, 10191–10196. (c) Yin, H.; Lee, G. I.; Sedey, K. A.; Rodriguez, J. M.; Wang, H. G.; Sebti, S. M.; Hamilton, A. D. *J. Am. Chem. Soc.* **2005**, *127*, 5463–5468. (d) Davis, J. M.; Truong, A.; Hamilton, A. D. *Org. Lett.* **2005**, *7*, 5405–5408. (e) Yin, H.; Lee, G. I.; Park, H. S.; Payne, G. A.; Rodriguez, J. M.; Sebti, S. M.; Hamilton, A. D. *Angew. Chem. Int. Ed.* **2005**, *44*, 2704–2707. (f) Kim, I. C.; Hamilton, A. D. *Org. Lett.* **2006**, *8*, 1751–1754.
- ²⁰⁷ van Lierop, J. E.; Wilson, D. P.; Davis, J. P.; Tikunova, S.; Sutherland, C.; Walsh, M. P.; Johnson, J. D. *J. Biol. Chem.* **2002**, *277*, 6550–6558.
- ²⁰⁸ (a) Orner, B. P.; Ernst, J. T.; Hamilton, A. D. *J. Am. Chem. Soc.* **2001**, *123*, 5382–5383. (b) Davis, J. M.; Tsou, L. K.; Hamilton, A. D. *Chem. Soc. Rev.* **2007**, *36*, 326–334.
- ²⁰⁹ Maity, P.; Konig, B. *Org. Lett.* **2008**, *10*, 1473–1476.
- ²¹⁰ Benedetti, B.; Bavoso, A.; Di Blasio, B.; Pavone, V.; Pedone, C.; Toniolo, C.; Bonara, G. M. *Proc. Natl. Acad. Sci. U.S.A.* **1982**, *79*, 7951–7954.
- ²¹¹ Toniolo, C.; Crisma, M.; Formaggio, F. *Biopolymers* **1997**, *40*, 627–651.
- ²¹² (a) Toniolo, C.; Benedetti, E. *Macromolecules* **1991**, *24*, 4004–4009. (b) Toniolo, C.; Crisma, M.; Formaggio, F.; Valle, G.; Cavicchioni, G.; Précigoux, G.; Aubry, A.; Kamphuis, J. *Biopolymers* **1993**, *33*, 1061–1072.
- ²¹³ Polese, A.; Formaggio, F.; Crisma, M.; Valle, G.; Toniolo, C.; Bonora, G. M.; Broxterman, Q.; Kamphuis, J. *Chem. Eur. J.* **1996**, *2*, 1104–1111.
- ²¹⁴ (a) Mutter, M.; Vuilleumier, S. *Angew. Chem. Int. Ed.* **1989**, *28*, 535–554. (b) Karle, I. L.; Balaram, P. *Biochemistry* **1990**, *29*, 6747–6756.
- ²¹⁵ (a) Hanson, P.; Millhauser, G.; Formaggio, F.; Crisma, M.; Toniolo, C. *J. Am. Chem. Soc.* **1996**, *118*, 7618–7625. (b) Gratias, R.; Konat, R.; Kessler, H.; Crisma, M.; Valle, G.; Polese, A.; Formaggio, F.; Toniolo, C.; Broxterman, Q.; Kamphuis, J. *J. Am. Chem. Soc.* **1998**, *120*, 4763–4770.
- ²¹⁶ Maity, P.; Konig, B. *Biopolymers* **2008**, *90*, 8–27.
- ²¹⁷ Aschi, M.; Lucente, G.; Mazza, F.; Mollica, A.; Morera, E.; Nalli, M.; Paradisi, M. P. *Org. Biomol. Chem.* **2003**, *1*, 1980–1988.
- ²¹⁸ Maity, P.; Zabel, M.; König, B. *J. Org. Chem.* **2007**, *72*, 8046–8053.
- ²¹⁹ (a) Ellis, T.K.; Martin, C.H.; Tsai, G.M.; Ueki, H.; Soloshonok, V.A. *J. Org. Chem.* **2003**, *68*, 6208–6214. (b) Komarov, I.V.; Grigorenko, A.O.; Turov, A.V.; Khilya, V.P.

- Russ. Chem. Rev.* **2004**, *73*, 785–810. (c) Vass, E.; Hollosi, M.; Besson, F.; Buchet, R. *Chem. Rev.* **2003**, *103*, 1917–1954.
- ²²⁰ Special Issue: Wu, Y.-D.; Gellman, S. *Acc. Chem. Res.* **2008**, *41*, 1231–1232.
- ²²¹ (a) Balducci, D.; Bottoni, A.; Calvaresi, M.; Porzi, G.; Sandri, S. *Tetrahedron: Asymmetry* **2006**, *17*, 3273–3281. (b) Paradisi, M.P.; Torrini, I.; Zecchini, G.P.; Lucente, G. *Tetrahedron* **1995**, *51*, 2379–2386. (c) Jimenez, A.I.; Ballano, G.; Cativiela, C. *Angew. Chem. Int. Ed.* **2005**, *44*, 396–399. (d) Toniolo, C.; Crisma, M.; Formaggio, F.; Peggion, C.; Broxterman, Q. B.; Kaptein, B. *Biopolymers* **2004**, *76*, 162–176.
- ²²² (a) Toniolo, C.; Crisma, M.; Formaggio, F.; Peggion, C.; Broxterman, Q.; Kaptein, B. *J. Inclusion Phenom.* **2005**, *51*, 121–136. (b) Hruby, V.J.; Agnes, R.S. *Biopolymers* **1999**, *51*, 391–410. (c) Tanaka, M. *Chem. Pharm. Bull.* **2007**, *55*, 349–358. (d) Etienne, M.A.; Aucoin, J.P.; Fu, Y.; McCarley, R.L.; Hammer, R.P. *J. Am. Chem. Soc.* **2006**, *128*, 3522–3523. (e) Rossi, P.; Felluga, F.; Tecilla, P.; Formaggio, F.; Crisma, M.; Toniolo, C.; Scrimin, P. *J. Am. Chem. Soc.* **1999**, *121*, 6948–6949. (f) Sissi, C.; Rossi, P.; Felluga, F.; Formaggio, F.; Palumbo, M.; Tecilla, P.; Toniolo, C.; Scrimin, P. *J. Am. Chem. Soc.* **2001**, *123*, 3169–3170. (g) Licini, G.; Bonchio, M.; Broxterman, Q. B.; Kaptein, B.; Moretto, A.; Toniolo, C.; Scrimin, P. *Biopolymers* **2006**, *84*, 97–104.
- ²²³ March, D.R.; Abbenante, G.; Bergman, D.A.; Brinkworth, R.I.; Wickramasinghe, W.; Begun, J.; Martin, J.L.; Fairlie, D.P. *J. Am. Chem. Soc.* **1996**, *118*, 3375–3379.
- ²²⁴ Balducci, D.; Emer, E.; Piccinelli, F.; Porzi, G.; Recanatini, M.; Sandri, S. *Tetrahedron: Asymmetry* **2005**, *16*, 3785–3794.
- ²²⁵ Toniolo, C.; Crisma, M.; Formaggio, F.; Peggion, C. *Biopolymers* **2001**, *60*, 396–419.
- ²²⁶ Ac₃c (1-aminocyclopropanecarboxylic acid) – Ac₉c (1-aminocyclononancarboxylic acid)
- ²²⁷ (a) Willis, H.; Hiller, W.; Hemmasi, B.; Bayer, E. *Tetrahedron* **1991**, *47*, 3047–3958. (b) Toniolo, C. *Biopolymers* **1989**, *28*, 247–257. (c) Crisma, M.; Bonora, G.M.; Toniolo, C.; Barone, V.; Benedetti, E.; Di Blasio, B.; Pavone, V.; Pedone, C.; Santini, A.; Fraternali, F.; Bavoso, A.; Lelj, F. *Int. J. Biol. Macromol.* **1989**, *11*, 345–352. (d) Perczel, A.; Hollosi, M.; Foxman, B.M.; Fasman, G.D. *J. Am. Chem. Soc.* **1991**, *113*, 9772–9784.
- ²²⁸ (a) Burgess, K.; Li, W. *Tetrahedron Lett.* **1995**, *36*, 2725–2728. (b) Moye-Sherman, D.; Jin, S.; Ham, I.; Lim, D.; Scholtz, J.M.; Burgess, K. *J. Am. Chem. Soc.* **1998**, *120*, 9435–9443. (c) Williams, R.M.; Fegley, G.J. *J. Org. Chem.* **1993**, *58*, 6933–6935. (d) Ma, D.; Ding, K.; Tian, H.; Wang, B.; Cheng, D. *Tetrahedron* **2002**, *13*, 961–969.

- ²²⁹ (a) Yokum, T.S.; Gauthier, T.J.; Hammer, R.P.; McLaughlin, M.L. *J. Am. Chem. Soc.* **1997**, *119*, 1167–1168. (b) Obrecht, D.; Altorfer, M.; Bohdal, U.; Daly, J.; Huber, W.; Labhardt, A.; Lehmann, C.; Mueller, K.; Ruffieux, R.; Schoenholzer, P. *Biopolymers* **1997**, *42*, 575–626. (c) Gershonov, E.; Granoth, R.; Tzeheval, E.; Gaoni, Y.; Fridkin, M. *J. Med. Chem.* **1996**, *39*, 4833–4843. (d) Burgess, K.; Ho, K.K. *J. Am. Chem. Soc.* **1994**, *116*, 799–800.
- ²³⁰ (a) Zhang, H.; Cai, Q.; Ma, D. *J. Org. Chem.* **2005**, *70*, 5164–5173. (b) Kuwabe, S. I.; Torraca, K. E.; Buchwald, S. L. *J. Am. Chem. Soc.* **2001**, *123*, 12202–12206. (c) Vorogushin, A. V.; Huang, X.; Buchwald, S. L. *J. Am. Chem. Soc.* **2005**, *127*, 8146–8149.
- ²³¹ Toniolo, C.; Formaggio, F.; Kaptein, B.; Broxterman, Q. *Synlett* **2006**, *9*, 1295–1310.
- ²³² Similar properties have been reported for N α -blocked tripeptides: Toniolo, C.; Benedetti, E. *ISI Atlas Sci. Biochem.* **1988**, *1*, 225–230.
- ²³³ (a) Crisma, M.; Formaggio, F.; Moretto, A.; Toniolo, C. *Biopolymers* **2006**, *84*, 3–12. (b) Donohue, J. *Proc. Natl. Acad. Sci. U.S.A.* **1993**, *39*, 470–478.
- ²³⁴ Görbitz, C.H. *Acta Crystallogr. B* **1989**, *45*, 390–395.
- ²³⁵ Moretto, A.; Formaggio, F.; Kaptein, B.; Broxterman, Q.B.; Wu, L.; Keiderling, T.A.; Toniolo, C. *Biopolymers* **2008**, *90*, 567–574.
- ²³⁶ (a) Wüthrich, K. H. *NMR of proteins and nucleic acids*, J. Wiley & Sons, New York, **1986**. (b) Clore, G.M.; Gronenborn, A.M. *Crit. Rev. Biochem. Mol. Biol.* **1989**, *24*, 479–564. (c) Clore, G.M.; Gronenborn, A.M. *Protein Eng.* **1987**, *1*, 275–288.
- ²³⁷ Ohmae, E.; Fukumizu, Y.; Iwakura, M.; Gekko, K. *J. Biochem.* **2005**, *137*, 643–652.
- ²³⁸ Davis, J.M.; Tsou, L.K.; Hamilton, A.D. *Chem. Soc. Rev.* **2007**, *36*, 326–334.
- ²³⁹ (a) Hünig, S.; Märkl, G.; Sauer, J. *Einführung in die apparativen Methoden in der Organischen Chemie*, 2nd Edition, Würzburg, Regensburg, 1994. (b) Author collective, *Organikum*, 17th Edition, VEB Deutscher Verlag der Wissenschaften, Berlin, 1988.
- ²⁴⁰ Lambert, J. N.; Mitchell, J. P.; Roberts, K. D. *J. Chem. Soc., Perkin Trans. 1* **2001**, 471–484.
- ²⁴¹ (a) Haubner, R.; Wester, H. J.; Weber, W. A.; Mang, C.; Ziegler, S. I.; Goodman, S. L.; Senekowitsch-Schmidtke, R.; Kessler, H.; Schwaiger, M. *Cancer Res.* **2001**, *61*, 1781–1785. (b) Assa-Munt, N.; Jia, X.; Laakkonen, P.; Ruoslahti, E. *Biochemistry* **2001**, *40*, 2373–2378.
- ²⁴² (a) Tyndall, J. D. A.; et. al. *J. Med. Chem.* **2000**, *43*, 3495–3504. (b) Reid, R. C.; Pattenden, L. K.; Tyndall, J. D. A.; Martin, J. L.; Walsh, T.; Fairlie, D. P. *J. Med.*

- Chem.* **2004**, *47*, 1641–1651. (c) Mak, C. C.; Brik, A.; Lewrner, D. L.; Elder, J. H.; Morris, G. M.; Olson, A. J.; Wong, C.-H. *Bioorg. Med. Chem.* **2003**, *11*, 2025–2040.
- ²⁴³ Toniolo, C.; Benedetti, E. *Trends Biochem. Sci.* **1991**, *16*, 350–353.
- ²⁴⁴ Torraca, K. E.; Huang, X.; Parrish, C. A.; Buchwald, S. L. *J. Am. Chem. Res.* **2001**, *123*, 10770–10771.
- ²⁴⁵ Ma, D.; Cai, Q. *Acc. Chem. Res.* **2008**, *41*, 1450–1460.
- ²⁴⁶ Gedye, R.; Smith, F.; Westaway, K.; Ali, H.; Baldisera, L.; Laberge, L.; Rousell, J. *Tet. Lett.* **1986**, *27*, 279–282.
- ²⁴⁷ Veverková, E.; Toma, S. *Chem. Pap.* **2008**, *62*, 334–338.
- ²⁴⁸ Wuts, P. G. M.; Greene, T. A. Benzyl Carbamate (Cbz- or Z-NR₂): PhCH₂OC(O)NR₂ (Chart 8). In *Greene's Protective Groups in Organic Synthesis*; John Wiley & Sons Inc., Hoboken, New Jersey, USA, 2007, pp 748–756.
- ²⁴⁹ (a) Gomtsyan, A.; et al. *Bioorg. Med. Chem. Lett.* **2007**, *17*, 3894–3899. (b) Brimble, M. A.; Brenstrum, T. J. *J. Chem. Soc., Perkin Trans. 1* **2001**, *2001*, 1612–1623. (c) Lévai, A. *Monatsh. Chem.* **1992**, *123*, 461–464.
- ²⁵⁰ (a) Chowdari, N. S.; Barbas, C. F. *Org. Lett.* **2005**, *7*, 867–870. (b) Ben-Ishai, D.; Berger, A. *J. Org. Chem.* **1952**, *17*, 1564–1570.
- ²⁵¹ Reid, R. C.; Kelso, M. J.; Scanlon, M. J.; Fairlie, D. P. *J. Am. Chem. Soc.* **2002**, *124*, 5673–5683.
- ²⁵² Maji, S.K.; Banerjee, R.; Velmurugan, D.; Razak, A.; Fun, H.K.; Banerjee, A. *J. Org. Chem.* **2002**, *67*, 633–639.
- ²⁵³ Banerjee, A.; Maji, S.K.; Drew, M. G. B.; Haldar, D.; Das, A. K.; Banerjee, A. *Tetrahedron* **2004**, *60*, 5935–5944.
- ²⁵⁴ Padwa, A.; Rashatasakhon, P.; Ozdemir, A.D.; Willis, J. *J. Org. Chem.* **2005**, *70*, 519–518.
- ²⁵⁵ Middleton, R. J.; Briddon, S. J.; Cordeaux, Y.; Yates, A. S.; Dale, C. L.; George, M. W.; Baker, J. G.; Hill, S. J.; Kellam, B. *J. Med. Chem.* **2007**, *50*, 782–793.

E. Appendix

Publications

Grauer, A.; Zabel, M.; Cabrele, C.; König, B. Efficient Synthesis of right- and left-handed Helices by the Use of C^α-tetrasubstituted Tetrahydrofuran α -Amino Acids. *J. Org. Chem.* **2009**, submitted.

Grauer, A.; Späth, A.; Ma, D.; König, B. Metal-catalyzed Derivatization of C^α-tetrasubstituted Amino Acids and Their Use in the Synthesis of Cyclic Peptides *Chem. Asia. J.* **2009**, submitted.

Grauer, A.; König, B. Synthesis of New C^α-Tetrasubstituted α -Amino Acids *Beilstein Journal of Organic Chemistry* **2009**, 5, No. 5.

Grauer, A.; König, B. Synthesis of (2R,3S)-((1R,2S,5R)-2-isopropyl-5-methylcyclohexyl) 2-(4-bromophenyl)-3-(tert-butoxycarbonylamino)-tetrahydrofuran-3-carboxylate and (2S,3R)-((1R,2S,5R)-2-isopropyl-5-methylcyclohexyl) 2-(4-bromophenyl)-3-(tert-butoxycarbonylamino)-tetrahydrofuran-3-carboxylate *MolBank* **2009**, submitted.

Grauer, A.; König, B. Synthesis of *rac*-tert-butyl 3-(benzyloxycarbonylamino)-2-(4-bromophenyl)-tetrahydrofuran-3-carboxylate *MolBank* **2009**, submitted.

Grauer, A.; Riechers, A.; Ritter, S.; König, B. Synthetic Receptors for the Differentiation of Phosphorylated Peptides with Nanomolar Affinities. *Chem. Eur. J.* **2008**, 14, 8922-8927.

Li, X.; Miltschitzky, S.; Grauer, A.; Michlova, V. König, B. Synthesis and Peptide-binding Properties of a Luminescent Pyrimidine Zinc(II) Complex. *Tetrahedron* **2006**, 62, 12191-12196.

Agoston, K.; Geyer, A.; König, B.; Kruppa, M.; Grauer, A. Combinatorial Chemistry and Solid Phase Synthesis: Seminar and Laboratory Course, **2008**.

Conferences

Summer School Medicinal Chemistry, Shanghai, V.R. China, September 2005

Funded by the EU-AsiaLink Medicinal Chemistry

1st EuCheMS Chemistry Congress, Budapest, Hungary, September 2006

Funded by the Karl-Ziegler-Institute

Wissenschaftsforum Chemie, Ulm, Germany, September 2007

Funded by the Gesellschaft Deutscher Chemiker e.V.

2nd EuCheMS Chemistry Congress, Turin, Italy, September 2008

Funded by the Karl-Ziegler-Institute

Curriculum Vitae

Personal Details

Name: Andreas Grauer
Date of Birth: 13.09.1979
Place of Birth: Neu-Ulm
Nationality: German
Status: single

Education

09.1990 – 07.1999 Grammar School, "König-Karlmann-Gymnasium",
Altötting, Germany

25.06.1999 A-Level (general qualification for university entrance)

07.1999 – 06.2000 Civilian Service, „Old people's and nursing home St.
Klara“, Altötting, Germany

10.2000 – 09.2005 Chemistry Studies, University of Regensburg,
Germany

01.2005 – 09.2005 Diploma Thesis in the research group of Prof. Dr. B.
König, University of Regensburg, Germany
Title: „Coordinative Recognition of Peptides Containing
N-terminal Histidine and Phosphorylated Tyrosine

28.09.2005 Diploma

10.2005 – 03.2009 PhD work in the research group of Prof. Dr. B. König,
University of Regensburg, Germany
Title: „Synthetic Receptors for the Differentiation of
Phosphorylated Peptides and Synthesis and Use of
Tetrahydrofuran Amino Acids”

Internships / Professional Experience

08.1997 Student trainee, Technical Department at Vinnolit
GmbH & Co. KG, Gendorf, Germany

08.1998 Student trainee, VCM-plant at Vinnolit GmbH & Co.
KG, Gendorf, Germany

07.2000 – 08.2000	Student trainee, S-PVC-plant at Vinnolit GmbH & Co. KG, Gendorf, Germany
08.2001 – 09.2001	Student trainee, EDC/VCM-plant at Vinnolit GmbH & Co. KG, Gendorf, Germany
11.2002 – 06.2003	Student assistant, research group of Prof. Dr. A. Pfitzner, University of Regensburg, Germany
03.2003	Practical Course „Chemical Engineering II“, „Karl-Winnacker-Institut der DECHEMA e.V.“, Frankfurt am Main, Germany
08.2003	Student Trainee, Chlorine-plant at Vinnolit GmbH & Co. KG, Gendorf, Germany
10.2005 – 03.2009	Graduate assistant, research group of Prof. Dr. B. König, University of Regensburg, Germany