

## Modelling and Simulation of Disc Brake Contact Analysis and Squeal

Abd Rahim Abu Bakar<sup>1</sup>, Huajiang Ouyang<sup>2</sup>, and Mohd Kameil Abdul Hamid<sup>1</sup>

<sup>1</sup>Department of Aeronautic and Automotive Technology  
Universiti Teknologi Malaysia  
81310 UTM Skudai, Johor,  
Malaysia

<sup>2</sup>Department of Engineering  
University of Liverpool  
Brownlow Street  
L69 3GH, Liverpool  
United Kingdom

Received Date: 29<sup>th</sup> August 2006    Accepted Date: 14<sup>th</sup> February 2007

---

### ABSTRACT

Predicting disc brake squeal by means of the complex eigenvalue method has been a popular approach in the brake research community owing to its advantages over the dynamic transient method. The positive real parts of the complex eigenvalue reflect the degree of instability of the brake system and are thought to indicate the likelihood of squeal occurrence. This paper studies the disc brake squeal using a detailed 3-dimensional finite element (FE) model of a real disc brake. First, the FE model is validated through modal analysis both at component and assembly levels. Then, a number of possible structural modifications for suppressing unstable vibration are carried out. The effect of contact pressure distributions on squeal propensity is also investigated. Lastly, a plausible modification is proposed which should result in reduced positive real parts of the eigenvalues and hence produce better squeal noise performance.

Keywords: Disc brake, contact analysis, complex eigenvalues, squeal, structural modifications.

### ABSTRAK

*Kaedah nilai eigen kompleks sering digunakan dalam meramal hingar "squeal" pada sistem brek cakera oleh komuniti penyelidikan sistem brek disebabkan kelebihanannya berbanding dengan kaedah dinamik fana. Bahagian nyata positif dalam kaedah nilai eigen kompleks memperlihatkan darjah ketidakstabilan dalam sistem brek dan seterusnya meramalkan terhasilnya hingar "squeal". Kertas kerja ini mengkaji hingar squeal bagi brek cakera menggunakan model 3 dimensi unsur terhingga. Di awal kajian, model tersebut diujisahkan melalui analisa modal pada peringkat komponen dan juga pemasangan. Seterusnya beberapa penambahbaikan struktur dilakukan bagi mengurangkan ketidakstabilan pada getaran. Kesan taburan tekanan sentuhan terhadap hingar squeal juga diselidiki. Akhir sekali, penambahbaikan yang sesuai dipilih*

*berdasarkan pengurangan/penghapusan bahagian nyata positif dalam nilai eigen dan seterusnya menghasilkan sistem brek yang bebas dari hingar squeal.*

*Kata kunci: Brek cakera, analisa sentuhan, nilai eigen kompleks, squeal, penambahbaikan struktur.*

## INTRODUCTION

Nowadays, passenger cars become one of the main transportation for people travelling from one place to another. Thus, quality issues in terms of noise and vibration of the passenger cars should be a major concern. One of vehicle components that occasionally generate unwanted noise and vibration is a disc brake system. As a result, carmakers, brake system and friction material suppliers face challenging tasks to reduce high warranty payouts. Akay (2002) stated that the warranty claims due to the brake noise, vibration and harshness (NVH) including brake squeal in North America alone were up to one billion dollars each year. Furthermore, Abendroth and Wernitz (2000) noted that many friction material suppliers had to spend up to 50 percent of their engineering budgets on the NVH issues.

The brake noise and vibration phenomena can be described based on the mechanism of generation. Disc brake noise and vibration can be divided into three categories, i.e. creep-groan, judder and squeal (Ouyang et al. 2003). The most troublesome and annoying noise is squeal, which is disturbing to both car passengers and environmental, and is expensive to the brake and the car manufacturers in terms of warranty costs (Crolla et al. 1991). The brake squeal is defined as a friction induced vibration and it generally occurs at frequencies above 1 kHz and is described as sound pressure level above 78 dB (Eriksson 2000).

In recent years, finite element method becomes one of popular tools in studying disc brake squeal (Liles 1989; Ripin 1995; Lee et al. 1998; Ouyang et al. 2003b; Kung et al. 2003; Bajer et al. 2003; Bajer et al. 2004). This is owing to the fact that experimental methods could not predict any squeal at early design stage. In addition, the finite element method capable of simulating any changes made on the disc brake components much faster and easier than the experimental. In order to predict squeal occurrence most researchers prefer to use complex eigenvalue analysis than dynamic transient analysis. Discussions on such analysis over the other methods are given in details in

(Ouyang et al. 2003a; Mahajan et al. 1999). The success of the complex eigenvalue method lies in the inclusion of the asymmetric friction stiffness matrix that may be derived from contact pressure analysis. The positive real parts of the complex eigenvalues reflect the degree of instability of the brake system and are thought to indicate the likelihood of squeal occurrence.

The contact pressure distribution in disc brakes has been investigated by a number of people. However, up to date, measuring dynamic contact pressure distribution remains impossible. Tumbrink (1989) attempted to measure static pressure distribution using a ball pressure method whilst Samie and Sheridan (1990) used a commercial pressure-sensitive film (Fuji Prescale film). There are also various methods available to measure static contact pressure distribution, which are not dedicated to the brake system. They are the polyethyleneterephthalate films (PET) (Nitta, 1995), a transferred oil film (Yamaguchi, et al. 1997) and the ultrasound reflection (Quinn et al. 2002; Pau et al. 2004). Contact pressure prediction by means of numerical method was studied in (Samie & Sheridan 1990; Tirovic & Day 1991; Ripin 1995; Lee et al. 1998; Hohmann et al. 1999; Tamari et al. 2000; Rumold & Swift 2002). There are several levels of complexity in disc brake models that have been developed in order to predict dynamic contact pressure distribution through numerical methods. For example Ripin (1995) only considered brake pads and a rigid surface of the disc in his 3-dimensional model. While Lee et al. (1998) adopted a deformable disc, however the calliper and the carrier were not included in their model. Tirovic and Day (1991), and Hohmann et al. (1999) included a deformable disc with more brake components than those in (Ripin 1995; Lee et al. 1998). The only works that considered all disc brake components and used deformable-to-deformable surfaces of the disc and pads are (Tamari et al. 2000; Rumold & Swift 2002).

Although continuous investigations have been carried out over decades, so far there is still no comprehensive solution for suppressing

brake squeal noise. Therefore, the motivations of this paper are to model and simulate disc brake contact analysis and later to predict squeal propensity. A detailed and full 3-dimensional finite element model of a real disc brake is developed. The paper also investigates effect of structural modifications on the onset of squeal. In the brake research community it has been speculated that the non-uniformity of the contact pressure may promote squeal. Therefore, it is the authors' intention to investigate further upon this claim. In the end, the authors may suggest the plausible modification that could improve squeal performance and hence might help create a quieter design of the car disc brake.

**FINITE ELEMENT MODEL**

A detailed 3-dimensional finite element (FE) model of a Mercedes solid disc brake assembly

is developed. Figures 1a and 1b show a real disc brake of floating calliper design and its FE model respectively. The FE model consists of a disc, a piston, a calliper, a carrier, piston and finger pads, two bolts and two guide pins. A rubber seal (attached to the piston) and two rubber washers (attached to the guide pins) in this brake assembly are not included in the FE model. Damping shims are also absent since they have been removed in the squeal experiments. The FE model uses up to 8 350 solid elements and approximately 37 100 degrees of freedom (DOFs). Figure 2 shows a schematic diagram of contact interaction that has been used in the disc brake assembly model. A rigid boundary condition is imposed at the boltholes of the disc and of the carrier bracket, where all six degrees of freedom are rigidly constrained.

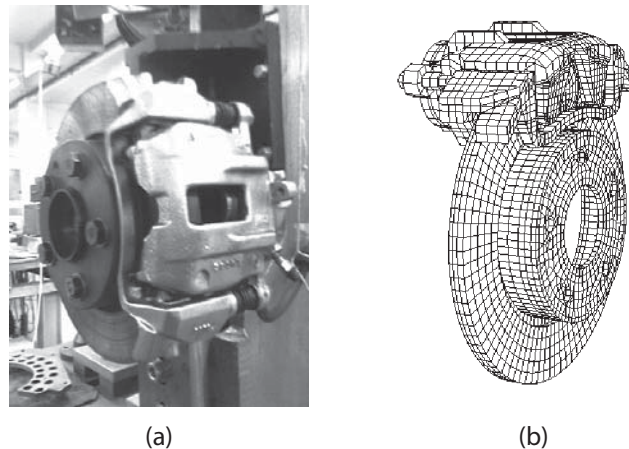

**FIGURE 1.** Disc brake assembly: (a) an actual disc brake (b) its FE model

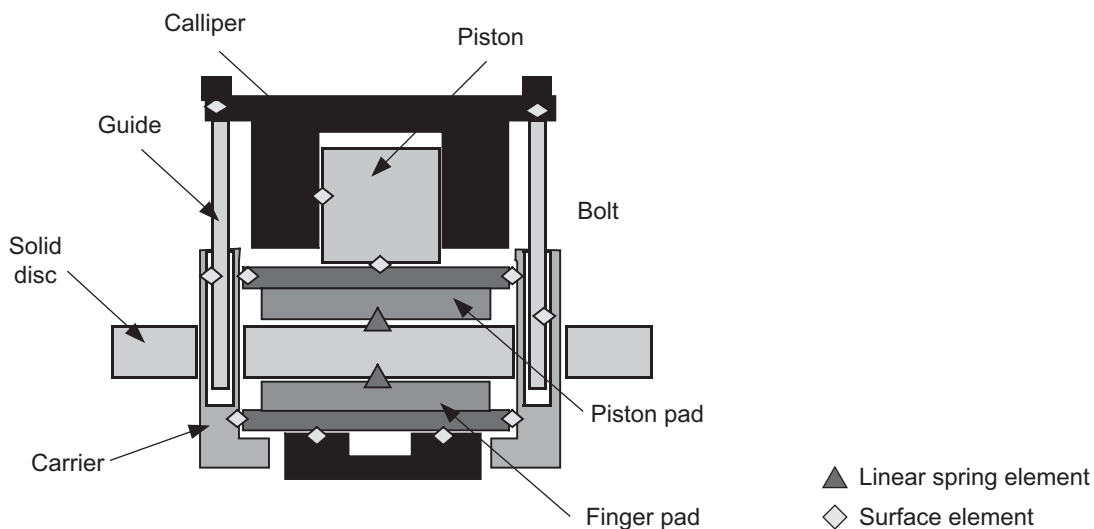

**FIGURE 2.** Schematic diagram of contact interaction in a disc brake assembly



well correlated with the experimental results. Hence tuning process in the density and Young's modulus is necessary to reduce relative errors between the two sets of results. Having tuned the material properties the maximum relative error is  $-0.5\%$  and are shown in Table 1. These results are based on the material properties given

form an assembly model. In the experimental modal analysis, a brake-line pressure of 1 MPa is imposed to the stationary disc brake assembly. A similar condition is also applied to the FE brake assembly model. In this validation, measurements are taken on the disc as it has a more regular shape than the other components.

**TABLE 3.** Modal results of the assembly measured on the disc

Mode	2ND	3ND	3ND	4ND	5ND	6ND	7ND
Test (Hz)	1287.2	1750.7	2154.9	2980.4	4543.7	6159.0	7970.0
FE (Hz)	1246.9	1730.1	2151.1	2966.2	4445.7	5837.1	8045.2
Error (%)	-3.1	-1.1	-0.1	-0.4	-2.1	-5.2	0.9

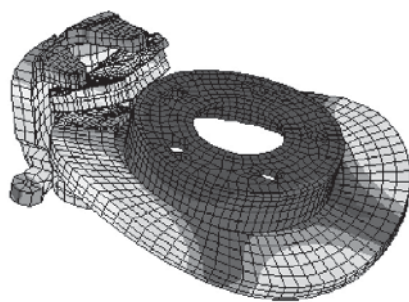

a) 2ND at 1246.9 Hz

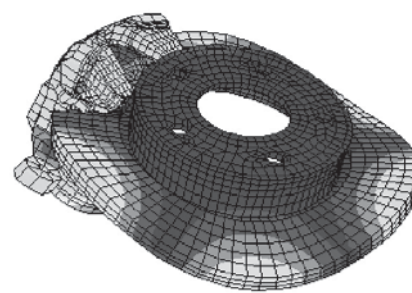

b) 3ND at 1730.1 Hz

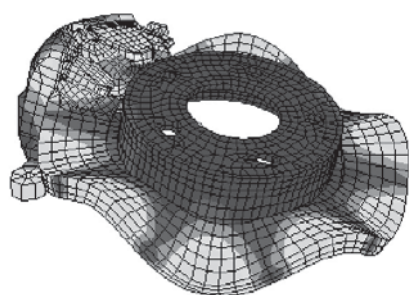

e) 5ND at 4445.7 Hz

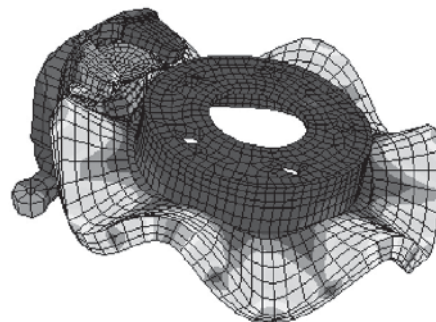

f) 6ND at 5837.1 Hz

**FIGURE 4.** Mode shapes of the assembly model

in Table 2. In this work, the FE model of the disc is validated by the authors and compared with the experimental data whilst the material data of the other components were validated and provided by an industry source.

The second stage of validation levels is to capture dynamic characteristics of the assembly model. The previous separated disc brake components must be coupled together now to

For the FE assembly model, spring stiffness values are firstly set to the magnitude of  $10^6$  N/m. A comparison is made between predicted and experimental results. If there are large relative errors, the spring stiffness values for linking two components need to be adjusted or updated. This updating process is continued until the relative errors are reduced to an acceptable level. After a number of attempts, good agreement between



predicted and experimental results is achieved. Figure 4 shows some of the mode shapes of the assembly model. Correlation between the two frequencies that include 2ND up to 7ND of the disc is given in Table 3. From the table, it is found that the maximum relative error is - 5.2 %. Having confident with the validation results, stability analysis using complex eigenvalues analysis can be performed.

### COMPLEX EIGENVALUES ANALYSIS

In order to perform the complex eigenvalue analysis using ABAQUS, four main steps are required (Kung et al. 2003). They are given as follows:

- Nonlinear static analysis for applying brake-line pressure
- Nonlinear static analysis to impose rotational speed on the disc
- Normal mode analysis to extract natural frequency of undamped system
- Complex eigenvalue analysis that incorporates the effect of friction coupling

In this analysis, the complex eigenvalues are solved using the subspace projection method. The eigenvalue problem can be written in the following form:

$$(\lambda^2 [M] + \lambda [C] + [K])\{\phi\} = 0 \quad (1)$$

where [M] is the mass matrix, [C] is the damping matrix, which can include friction-induced damping effects as well as material damping contribution and [K] is the unsymmetric (due to friction) stiffness matrix. This unsymmetrical stiffness matrix leads to both complex eigenvalues and eigenvectors. In the third step stated above,

the symmetric eigenvalue problem is first solved, by dropping damping matrix [C] and the unsymmetric contributions to the stiffness matrix [K], to find the projection subspace. Therefore the eigenvalue,  $\lambda$  becomes a pure imaginary where  $\lambda = i\omega$ , and the eigenvalue problem now becomes:

$$(-\omega^2 [M] + [K_s])\{\phi\} = 0 \quad (2)$$

where  $K_s$  is the symmetric stiffness. This symmetric eigenvalue problem then is solved using subspace eigensolver. The next step is that the original matrices are projected in the subspace of real eigenvectors and given as follows:

$$[M^*] = [\phi_1 \dots \phi_n]^T [M] [\phi_1 \dots \phi_n], \quad (3a)$$

$$[C^*] = [\phi_1 \dots \phi_n]^T [C] [\phi_1 \dots \phi_n], \quad (3b)$$

$$[K^*] = [\phi_1 \dots \phi_n]^T [K] [\phi_1 \dots \phi_n], \quad (3c)$$

where [M\*], [C\*] and [K\*] are the recovered mass, damping and stiffness matrices.

Now the eigenvalue problem is expressed in the following form:

$$(\lambda^2 [M^*] + \lambda [C^*] + [K^*])\{\phi^*\} \quad (4)$$

The reduced complex eigenvalues problem is then solved using the QZ method for a generalized nonsymmetrical eigenvalue problem. The eigenvectors of the original system are recovered by the following:

$$\{\Phi\}^k = [\phi_1 \dots \phi_n] \{\Phi^*\}^k \quad (5)$$

where  $\{\Phi\}^k$  is the approximation of the k-th eigenvector of the original system.

**TABLE 4.** Squeal frequencies generated in the experiment

Operating Conditions		Mode	Squeal
Pressure (MPa)	Speed (rad/s)	Nodal Diameter	Frequency (Hz)
0.16	26.0	4	2944.4
"	"	6	6797.1
0.22	6.3	5	4275.1
0.34	3.2	3	1755.6
0.83	6.3	7	7540.2

In this paper, four different pressures and rotation speeds of the baseline model are examined. Table 4 shows squeal frequencies generated in the experiment. Squeal prediction by finite element model is illustrated in Figure 5. The prediction shows more unstable frequencies and this is simply due to neglecting components' material damping. Nevertheless, there is good agreement between FE calculations and experimental results. The distributions of contact pressure that calculated about centerline of the pad are depicted in Figure 5. It is shown that high contact pressure occurred at the leading edge

than the trailing, which gave almost zero pressure for the piston pad. While, for the finger pad zero pressure generated in the middle of the pad and high pressure remains at the leading edge.

than the baseline model. These modifications generate more unstable frequencies above 7000 Hz, as shown in Figure 7. By removing some spring elements at certain location between the piston and the piston-pad back plate, and between the finger and the finger-pad back plate (M2) as shown in Figure 8, unstable frequencies above 6000 Hz are eliminated. However, most of the unstable frequencies below this frequency remain. Thus, this is not a favourable modification either. Combining M2 with M3 and M5 seems to be a promising solution as most of the unstable

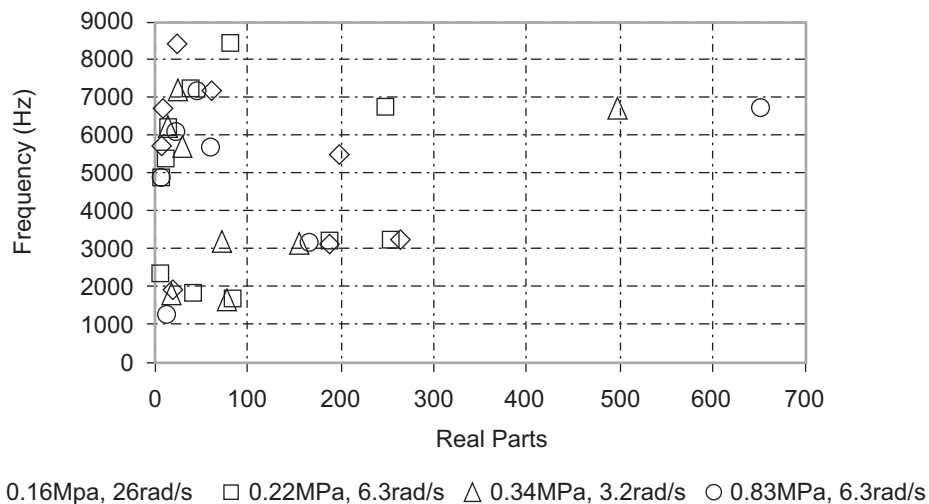

FIGURE 5. Prediction of unstable frequencies at different pressure and speeds of baseline model

than the trailing, which gave almost zero pressure for the piston pad. While, for the finger pad zero pressure generated in the middle of the pad and high pressure remains at the leading edge.

### STRUCTURAL MODIFICATIONS

Generally, structural (including material) modifications are a favourite means of improving squeal performance of the disc brake. In this paper, several structural modifications are simulated and they are explained in Table 5. Figure 7 shows predicted unstable frequencies of the modified structure at pressure of 0.83 MPa and speed of 6.3 rad/s. It is shown that M1, M4 and M5 do not make any improvement on noise performance since they generate the same unstable frequencies as obtained in the baseline model. M3, M1+M2 and M2+M4 are not favourable modifications either since more unstable frequencies are generated

frequencies are eliminated except one at frequency 8600 Hz. Therefore, the authors regarded this modification as a plausible one. Now, it is interesting to see the distributions of contact pressure of these modifications.

The contact pressure distributions at the piston and the finger pads are shown in Figure 9. For the piston pad, M1, M4 and M5 follow exactly the same trend of the baseline model whilst M3 almost produces the same magnitude of pressure of the baseline model except in the middle of the pad, where the pressure fluctuates mildly due to the presence of the slot. The rest of the modifications produce slightly different results, where the contact pressure is much higher at the trailing edge and slightly lower at the leading edge, than those of the baseline model. Pressure fluctuation also occurs in the middle of the pad for M1+M2. For the finger pad, M1, M3, M4 and

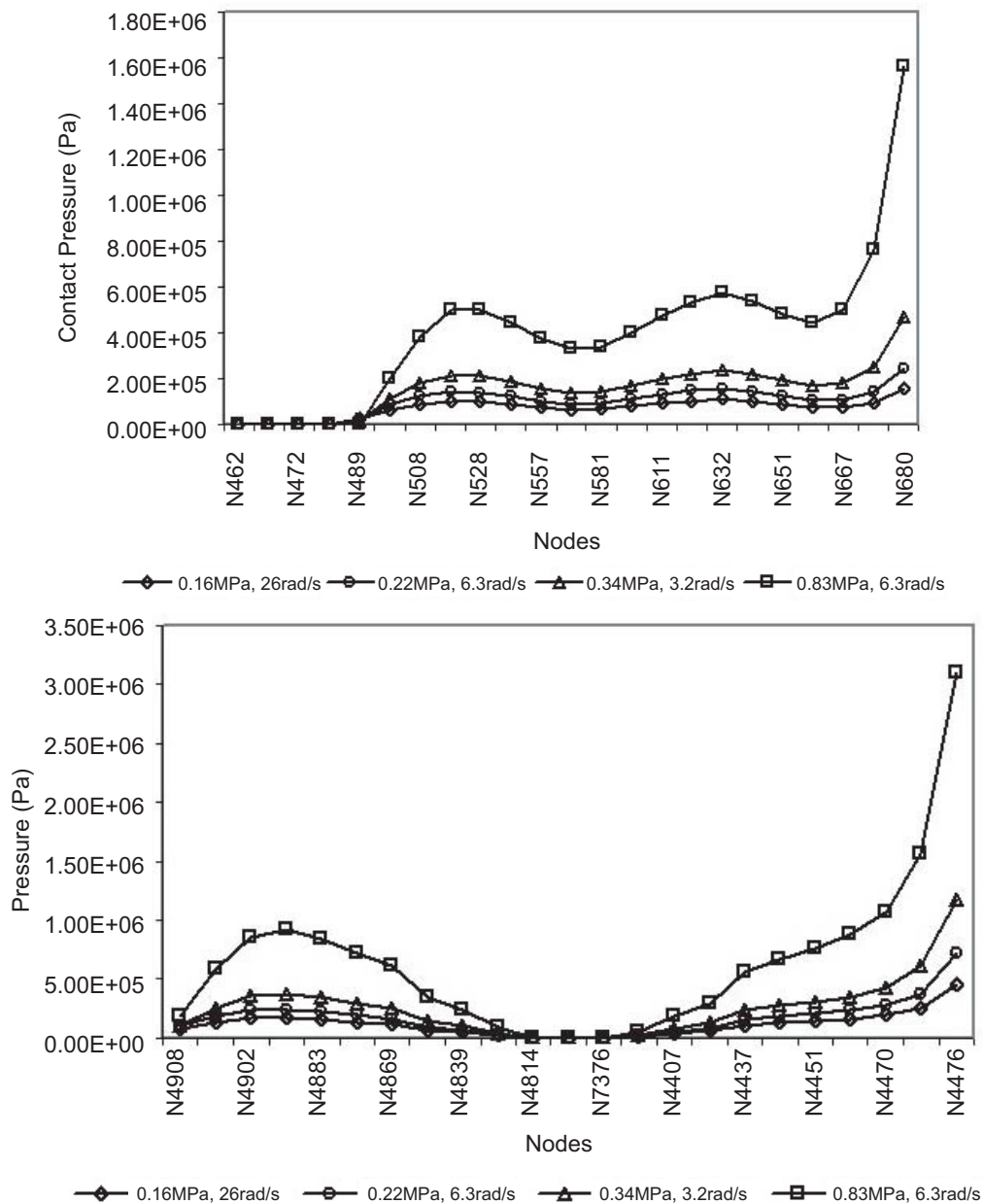
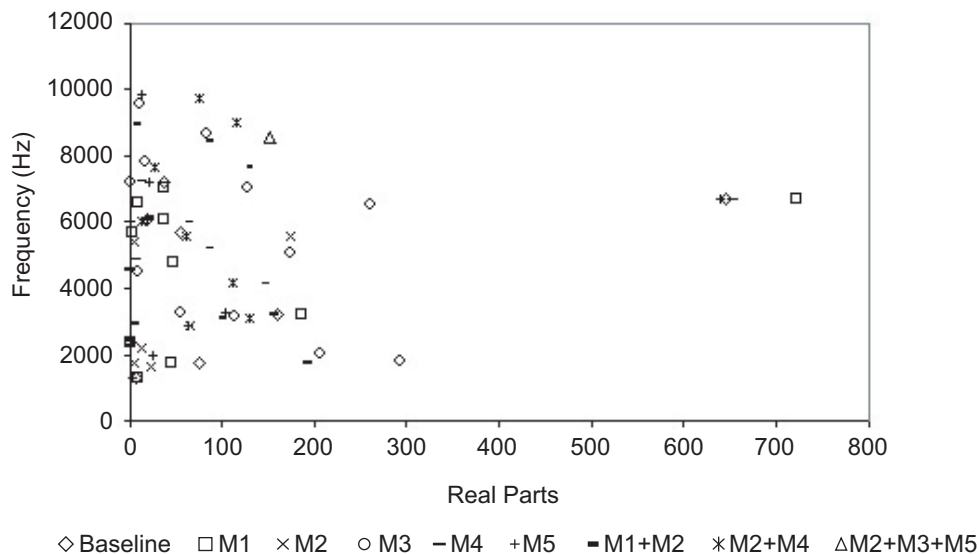

**FIGURE 6.** Contact pressure distribution at piston pad (top) and finger pad (bottom). Right hand side of the diagram is the leading edge of the pad.

**TABLE 5.** Structural and material modifications

No	Modifications	Descriptions
1	Baseline	Unmodified
2	Slotted pad (M1)	Centre of the pad
3	Finger & piston partial connection (M2)	See Fig.8
4	Stiffer disc (M3)	$E=150\text{GPa}$
5	Vented Disc (M4)	22 slots
6	Stiffer calliper (M5)	$E = 700 \text{ GPa}$
7	M1+M2	
8	M2+M4	
9	M2+M3+M5	





**FIGURE 7.** Unstable frequencies of modified structures and material

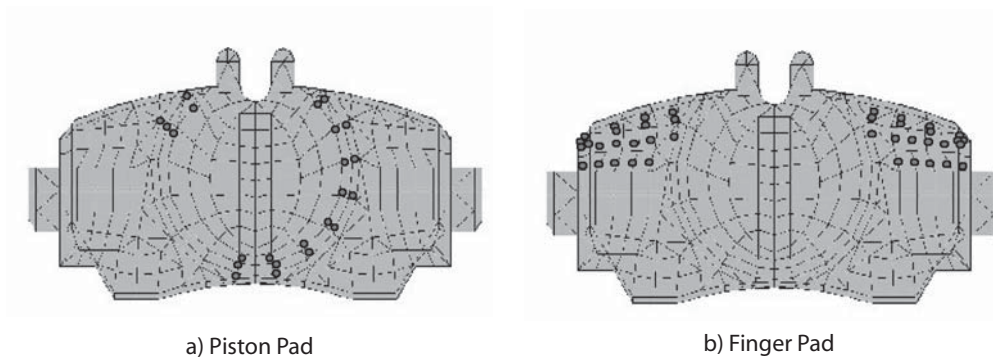

**FIGURE 8.** Partial connections in the axial direction (the red dot represents removal of one axial connection)

M5 lead to exactly the same trend of the baseline model whilst the rest produce slightly higher contact pressure at the trailing edge.

Comparison of different structural modifications in terms of the respective contact pressure distribution at the piston and the finger pads and the unstable frequencies obtained previously seems to suggest that a favourable contact pressure distribution alone is not good enough to suppress the occurrence of squeal. It can be seen that even though M2 produces almost the same magnitude of the contact pressure of M2+M4, the resultant unstable frequencies are different. The reason why M2+M3+M5 eliminates most of the unstable frequencies below 8000 Hz is due to mode decoupling between and/or within the pad, the disc and the calliper. Chen et al. (2003) stated that decouple rotor in-plane and out-of-plane modes, and decouple pad/caliper modes are part of the strategies for the effective way to reduce or eliminate squeal.

**CONCLUSIONS**

This paper investigates the influence of contact pressure distributions on the squeal occurrence as a result of structural modifications. Prior to the complex eigenvalue analysis the finite element model of a real disc brake was validated through modal analysis, where good correlations are obtained at components and assembly level. There is also good agreement in squeal predictions between the FE model and experimental results. Several structural modifications are simulated. From the results, it is suggested that combined modification, i.e. partial connections the piston and the piston-pad back plate and between the finger and the finger-pad back plate, a stiffer caliper and a stiffer disc can eliminate unstable frequencies below 8000 Hz, which are dominant in the baseline model. Therefore, this modification is regarded as a plausible one. From the contact pressure point of view, it seems that shifting

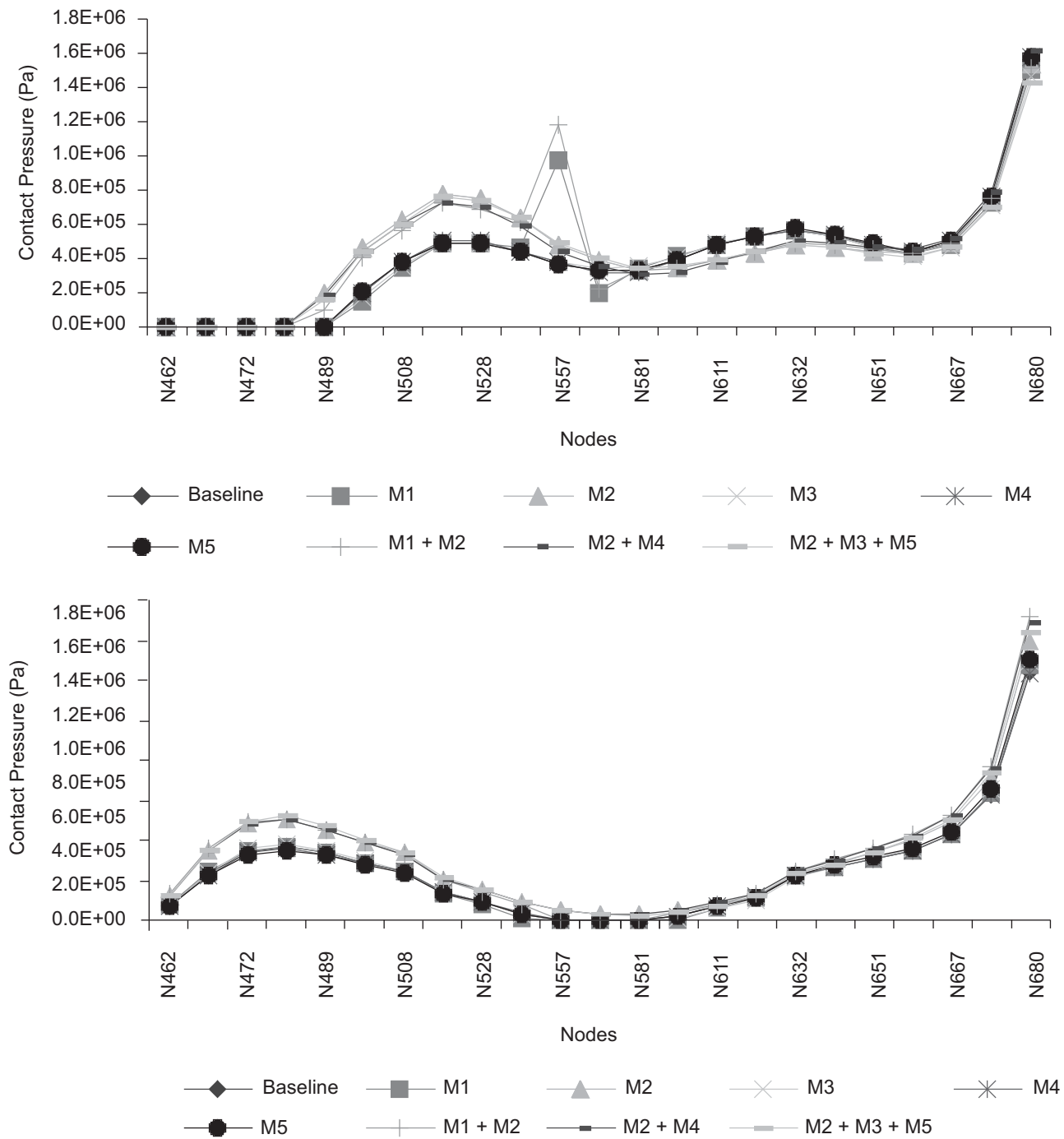

**FIGURE 9.** Contact pressure distribution of structural modifications at piston pad (top) and finger pad (bottom)

the pressure towards the trailing edge alone is insufficient to suppress unstable frequencies. Mode decoupling between and/or within the components stated aforementioned is believed to be another factor in eliminating unstable frequencies below 8000 Hz.

**ACKNOWLEDGEMENTS**

The first author would like to thank the following for their contributions and supports: Dr S James (University of Liverpool), Dr Q Cao (University of Aberdeen), TRW Automotive, and Universiti Teknologi Malaysia.

## REFERENCES

- Abendroth, H. & Wernitz, B. 2000. The integrated test concept dyno-vehicle; performance and noise. *S.A.E Technical Paper* 2000-01-2774.
- Akay, A. 2002. Acoustics of friction. *J. Acoust. Soc. Am.* 111(4):1525-1548.
- Bajer, A., Belsky, V. & Kung, S. 2004. The influence of friction-induced damping and nonlinear effects on brake squeal analysis. *S.A.E. Technical Paper* 2004-01-2794.
- Bajer, A., Belsky, V. & Zeng, L.J. 2003. Combining a nonlinear static analysis and complex eigenvalue extraction in brake squeal simulation. *S.A.E Technical Paper* 2003-01-3349.
- Chen, F., Tong, H., Chen, S.E. & Quaglia, R.L. 2003. On automotive disc brake squeal Part IV: Reduction and prevention. *S.A.E. Technical Paper* 2003-01-3345.
- Crolla, D.A. & Lang, A.M. 1991. Brake noise and vibration – The state of the art. *Vehicle Tribology Leeds-Lyon Tribology Series* 18: 165-174.
- Eriksson, M. 2000. Friction and contact phenomenon of disc brakes related to squeal. PhD Thesis, Faculty of Science and Technology, Uppsala University.
- Hohmann, C., Schiffner, K., Oerter, K. and Reese, H. 1999. Contact analysis for drum brakes and disk brakes using ADINA. *Computers and Structures* 72: 185-198.
- Kung, S., Steizer, G., Belsky, V. and Bajer, A. 2003. Brake squeal analysis incorporating contact conditions and other nonlinear effects. *S.A.E. Technical Paper* 2003-01-3343.
- Lee, Y.S., Brooks, P.C., Barton, D.C. & Crolla, D. A. 1998. A study of disc brake squeal propensity using a parametric finite element model. *IMechE*, C521/009/98: 191-201.
- Liles, G. D. 1989. Analysis of disc brake squeal using finite element methods. *S.A.E. Technical Paper* 891150.
- Mahajan, S. K., Hu, Y. & Zhang, K. 1999. Vehicle disc brake squeal simulations and experiences. *S.A.E. Technical Paper* 1999-01-1738.
- Nitta, I. 1995. Measurements of real contact areas using PET films (thickness, 0.9 $\mu$ m). *Wear* 181-183: 844-849.
- Ouyang, H., Cao, Q., Mottershead, J.E. & Treyde, T. 2003. Vibration and squeal of a disc brake: modelling and experimental results. *Proc. Instn. Mech. Engrs, Part D: J. Automobile Engineering* 217: 867-875.
- Ouyang, H., Nack, W. V., Yuan, Y. & Chen, F. 2003. On automotive disc brake squeal Part II: simulation and analysis. *S.A.E. Technical Paper* 2003-01-0684.
- Pau, M., Baldi, A., Orrú, P.F., & Ginesu, F. 2004. Experimental investigation on contact between cylindrical conformal surfaces. *J. Strain Analysis* 39(3): 315-328.
- Quinn, A.M., Drinkwater, B.W. & Dwyer-Joyce, R.S. 2002. The measurement of contact pressure in machine elements using ultrasound. *Ultrasonics* 39: 495-502.
- Ripin, Z.B.M. 1995. Analysis of Disc Brake Squeal Using the Finite Element Method. PhD Thesis, Department of Mechanical Engineering, University of Leeds.
- Rumold, W. and Swift, R.A. 2002. Evaluation of disc brake pad pressure distribution by multibody dynamic analysis. *Proc. of International Conference on Vehicle Brakes*, Ed. D Barton and B Shilton, Professional Engineering Publishing Ltd., Bury St Edmund, UK.
- Samie, F. and Sheridan, D. C. 1990. Contact analysis for a passenger car disc brake. *S.A.E. Technical Paper* 900005.
- Tamari, J., Doi, K. and Tamasho, T. 2000. Prediction of contact pressure of disc brake pad. *JSAE Review* 21: 136-138.
- Tumbrink, H.J. 1989. Measurement of load distribution on disc brake pads and optimization of disc brakes using the ball pressure methods. *S.A.E. Technical Paper* 890863.
- Yamaguchi, K., Uchida, M. and Abraha, P. 1997. Measurement of the pressure distribution on contact surfaces by detection of a transferred oil film. *Surface Sciences*, 377-379: 1015-1018.