

# Optical Generation and Wireless Transmission of 60 GHz OOK Signals Using Gain Switched Laser

H. Shams, P. M. Anandarajah, P. Perry, and L.P. Barry

*Research Institute for Networks and Communication Engineering (RINCE), Department of Electronic Engineering, Dublin City University (DCU), Dublin 9, Ireland*

*Author e-mail address: [Haymen.shams@eeng.dcu.ie](mailto:Haymen.shams@eeng.dcu.ie)*

**Abstract:** We present a novel, simple and cost effective system for optical millimeter-wave generation and transmission of 3 Gbps data based on gain switching. System performance has been investigated, including wireless transmission and power budget analysis.

©2010 Optical Society of America

**OCIS codes:** (060.2330) Fiber optics communications; (060.5625) Radio frequency photonics

## 1. Introduction

Millimeter waves (mm-waves) provide a wide band of spectrum for high-bandwidth wireless connectivity over a short range [1, 2]. In order to provide high capacity coverage with mm-wave systems, radio-over-fiber (RoF) is an attractive solution for extending the reach of mm-wave systems since the optical link has a very low loss, immunity to electromagnetic interference, and is capable of transmitting large bandwidth signals. In such a system, signals are generated in the central station (CS) and distributed to a large number of remote antenna units (RAUs) via optical fiber cables. This results in the cost sensitive equipment being located at the central station, with the cost being shared between a large number of terminals. In addition, this type of system simplifies and reduces the cost of the RAUs as the requirements for up conversion and a local oscillator in the RAU are eliminated.

Optical mm-wave generation and all optical up-conversion techniques have recently attracted significant interest due to the low cost and improved performance for signal distribution. Remote heterodyne receivers are commonly used to generate mm-waves [3], where the two correlated optical carriers are generated at the CS with a frequency offset equal to the mm-wave frequency. The carriers are then transmitted through optical fiber and beat at the high speed photodetector. Many techniques have been reported that employ external intensity modulators to generate frequency doubling or quadrupling of the driven RF sinusoid signal [4, 5]. This method requires an external modulator which increases both loss and cost, and is more susceptible to bias drifting of the modulators, which can affect the output spectrum. The work reported here is based on the use of optical filters to select only two optical modes, separated by the desired mm-wave frequency, from a gain switched laser (GSL) spectrum [6, 7] and to use that technique in a viable system experiment. These two optical modes are phase locked because they are derived from the same laser light source. Therefore, the spectral linewidth of the generated mm-wave at the high speed photodiode does not depend on the laser linewidth, but only on the purity of the signal that drives the laser.

The system performance has been investigated by measuring the bit error rate (BER) and the eye diagrams for the baseband signals after wireless transmission. This system can easily generate high mm-wave frequencies with a stable spectrum with less cost and complexity than comparable systems, since it uses only one MZM to modulate the data and needs only a modest laser drive frequency.

## 2. Experimental generation and distribution system

The proposed schematic diagram for the optical generation and downstream data transmission in a mm-wave is shown in Fig. 1 and is divided into three sections. The (CS) consists of a commercial distributed feedback laser diode (DFB-LD) with an emission wavelength of 1551 nm, at room temperature, and a threshold current of 15 mA. The gain switching of the DFB-LD is achieved by amplifying a 15 GHz RF sinusoidal signal which is combined with an adjustable DC current via a bias tee. The generated gain switched spectrum is captured by a high-resolution optical spectrum analyzer (OSA) and is shown in Fig.2 (a). The spectrum shows that the generated comb consists of eight central sidebands covering a total spectral range of 105 GHz, with a maximum power difference between the comb lines of only 5 dB. After that, the optical comb is amplified by using an erbium doped fiber amplifier (EDFA) and then filtered.

## OTh07.pdf

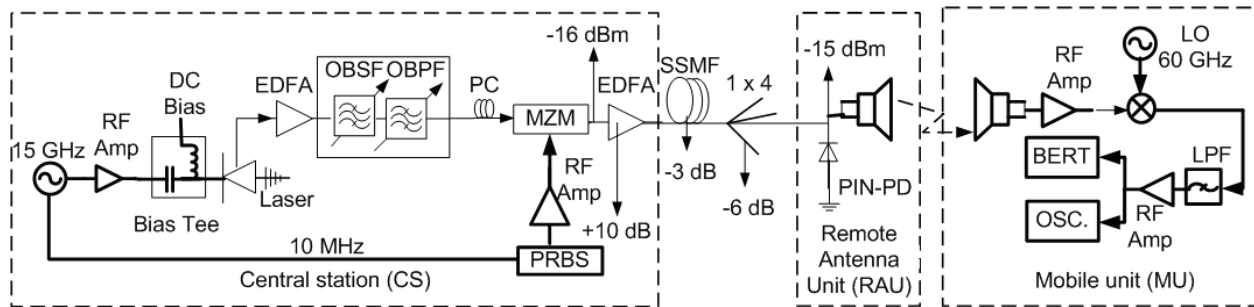

Fig. 1. Schematic diagram of the generation and modulation of 60 GHz using a gain switching technique

To generate a 60 GHz mm-wave signal, an optical band stop filter (OBSF) is used to suppress the middle components and an optical band pass filter (OBPF) is used for the outer sidebands. After filtering, the polarization controller (PC) is used to change the polarization for the optical signal before being fed into the Mach–Zehnder modulator (MZM). The MZM is driven by a 3 Gbps non return to zero on-off-keying (NRZ-OOK) data stream (with a  $2^{31}-1$  word length) generated by using a pseudo-random bit sequence (PRBS) synchronized with 10 MHz from the RF sinusoidal signal that drives the laser diode. The modulated optical signal is shown in Fig.2 (b) where the modulation is clearly visible on both main tones. The suppressed sidebands are shown around 20 dB lower than the main sidebands. This level of suppression was limited by the optical filters available, and much better suppression could be achieved by employing a specially designed Bragg filter which has two band pass wavelengths separated by the required frequency, to select the two optical carriers.

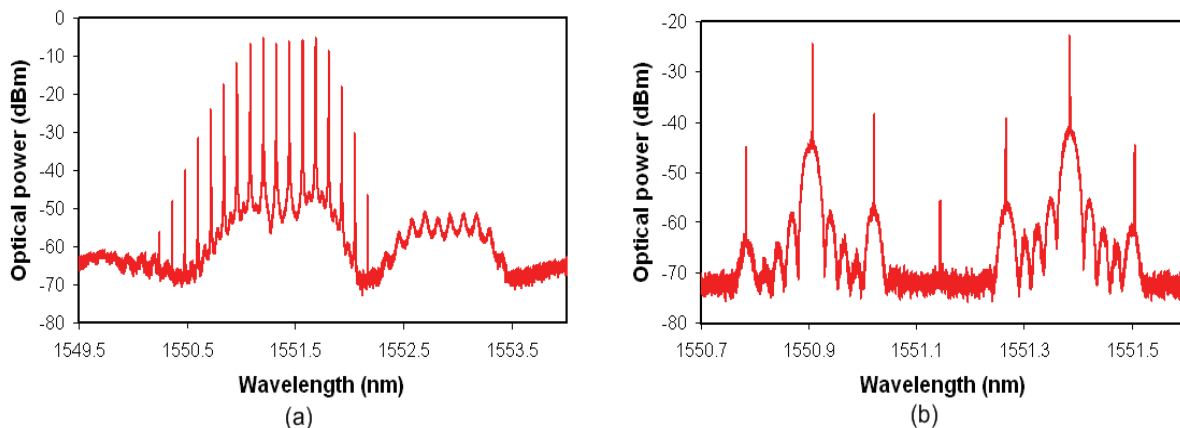

Fig. 2. (a) The optical spectrum for GSL, and (b) the optical spectrum of the filtered and modulated GSL.

This signal is transmitted over a 3 km span of standard single mode fiber (SSMF) to multiple RAUs, where it is photodetected by a high speed photodiode with a 3 dB bandwidth of 70 GHz and a dc responsivity of 0.6 A/W. The two sidebands beat together in the receiver and generate a modulated 60 GHz mm-wave signal. The generated electrical signal is directly transmitted over the air by using a standard 20 dBi horn antenna. The waveguide and antenna work as a bandpass filter and only transmit the required signal at 60 GHz and remove the baseband signal and other harmonic signals.

In the mobile unit (MU), the mm-wave signal is received using another 20 dBi horn antenna and is amplified by using a mm-wave amplifier. The received signal is down-converted to baseband after mixing it with a 60 GHz local oscillator, then filtered by using a low pass filter (LPF) and amplified. The bit error rate (BER) is analyzed by a bit error rate tester (BERT) for different wireless transmission distances. The eye diagrams are also recorded by using a high speed digital sampling oscilloscope (OSC).

### 3. Experimental Results and Discussion

In Fig. 3, the measured BER is plotted versus the received optical power for back-to-back (BTB), 1.5 m, and 2 m wireless lengths. The eye diagrams of the electrical recovered baseband signals are shown as insets in the same figure for BTB and 2 m wireless transmission, as can be seen they are clear and open. This system has an error free performance for a sufficiently high optical received power, however, the BER measurements were taken from BER

of  $10^{-7}$ , as these BER values are common for radio transmission and will be improved if the system uses a forward error correction technique. As shown in Fig. 3, the BTB receiver sensitivity is -33 dBm and the measured power penalty after wireless transmission over 1.5 m and 2 m is 4.7 dB and 8 dB, respectively. The wireless transmission lengths were also plotted versus the receiver sensitivity in Fig. 4 for different BER ( $< 10^{-6}$  and  $10^{-4}$ ). For BER  $< 10^{-6}$ , the received optical power is -25 dBm at 2 m transmission, while, the measured sensitivity is -29 dBm at BER  $< 10^{-4}$ .

The optical power budget for our system was also calculated to show the expected system performance in a practical set-up with a distribution to four RAUs. As shown in Fig. 1, the output power of the transmitter is -16 dBm after the modulator, and the received optical power at the RAU is -15 dBm. For BER  $< 10^{-6}$ , the receiver sensitivity is -25 dBm, which would give a power margin of 10 dB which allows a further 8-way split in the system or a three-fold increase in radio transmission distance. Alternatively, the second EDFA can be removed while maintaining the same split ratio and transmission distance. A practical commercial system would also use a specially designed filter which should have a lower pass band loss and a more sensitive detector to give a higher power margin. It should also be noted that the MU can use a simple filter-based carrier recovery technique instead of the 60GHz LO to further reduce costs [8].

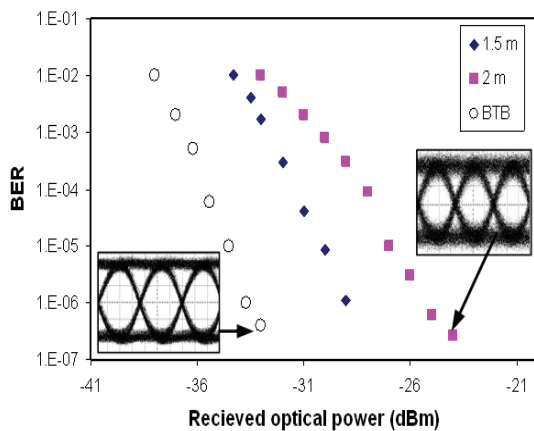

Fig. 3. The BER versus received optical power for 3 km transmission over fiber

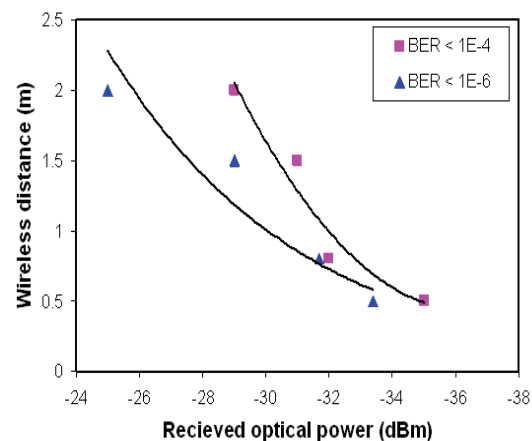

Fig. 4. The wireless distance transmission versus the received optical fiber for BER  $< 10^{-6}$ , and  $10^{-4}$ .

#### 4. Conclusions

In this paper, we have proposed a novel method for the generation and transmission of a 3 Gbps downlink stream in a UWBoF system operating at 60 GHz, based on a gain switched DFB-LD. The generated comb spectrum from the GSL is filtered by using appropriated filters to select two optical sidebands which are then OOK modulated with a 3 Gbit/s data signal. This system presents a much simpler and lower cost transmitter than the commonly used MZM approach. The power budget analysis also shows that this transmitter can yield a viable distribution system.

**Acknowledgments:** This work is sponsored by Science Foundation Ireland Research Frontiers Programme and an Enterprise Ireland Technology Development Phase Grant.

#### 5. References

- [1] M. Weiß, M. Huchard, A. Stohr, B. Charbonnier, S. Fedderwitz, and D. S. Jager, "60-GHz Photonic millimeter-wave link for short- to medium-range wireless transmission up to 12.5 Gb/s," *J. Lightwave Technol.* **26**, 2424-2429 (2008).
- [2] P. Smulders, "Exploiting the 60 GHz band for local wireless multimedia access: prospects and future directions," *IEEE Communications Magazine* **40**, 140-147 (2002).
- [3] R. Kashyap, J. Yao, K. Wu, and X. Zhang, "Techniques for photonic generation of millimeter-wave signals," in 2007 Digest of the IEEE/LEOS Summer Topical Meetings (2007), pp. 188-189.
- [4] J. Yu, Z. Jia, T. Wang, and G. K. Chang, "Centralized lightwave radio-over-fiber system with photonic frequency quadrupling for high-frequency millimeter-wave generation," *IEEE Photonics Technology Letters* **19**, 1499-1501 (2007).
- [5] J. Yu, Z. Jia, T. Wang, and G. Chang, "A novel radio-over-fiber configuration using optical phase modulator to generate an optical mm-wave and centralized lightwave for uplink connection," *IEEE Photonics Technology Letters* **19**, 140-142 (2007).
- [6] D. Novak, Z. Ahmed, R. B. Waterhouse, and R. S. Tucker, "Signal generation using pulsed semiconductor lasers for application in millimeter-wave wireless links," *IEEE Trans. Microwave Theory Tech.* **43**, 2257-2262 (1995).
- [7] H. Shams, P. M. Anandarajah, P. Perry, and L. P. Barry, "Optical millimeter-wave generation and transmission system for 1.25Gbit/s downstream link using a gain switched laser" *Opt. Commun.* (2009).
- [8] A. Kaszubowska-Anandarajah, P. Perry, L. P. Barry, and H. Shams, "An IR-UWB photonic distribution system," *IEEE Photon. Technol. Lett.* **20**, 1884-1886 (2008).