

# AUTONOMOUS, DEPLOYABLE SENSING DEVICE

Salzitsa Anastasova<sup>1</sup>, Conor Slater<sup>1</sup>, Aleksandar Radu<sup>1</sup>, Johan Bobacka<sup>2</sup>, Andrzej Lewenstam<sup>2</sup>, Marek Danielwski<sup>3</sup>, Dermot Diamond<sup>1</sup>

**CLARITY**  
clarity-centre.org

<sup>1</sup>CLARITY; The Centre for Sensor Web Technologies, National Centre for Sensor Research, School of Chemical Sciences, Dublin City University, Glasnevin, Dublin 9, Ireland

<sup>2</sup>Abo Akademi, Tuomiokirkontori 3, FI-20500, Turku, Finland

<sup>3</sup>AGH University of Science and Technology, Mickiewiczza 30, 30-059 Krakow, Poland

**OVERVIEW:** The recent progress in lowering of the detection limit of ion-selective electrodes (ISEs), as well as their simple construction, low production cost and low power requirements, make ISEs ideal candidates for detector systems that can be integrated into autonomous, deployable sensing devices. Routine analysis and early warning systems are applications that first spring to mind, however great added value can be obtained by integration of many such devices into a wireless sensing network.

In this paper we describe our progress towards the miniaturization of ISEs with an integrated all-solid-state reference electrode to produce an all-solid-state sensor that could be further integrated into an autonomous, deployable sensing device. This work has two avenues: 1) development of a platform that can house all-solid-state ISEs and reference electrodes and 2) development of electronic circuitry for data acquisition and *wireless* transmission of the data. The latter utilizes novel, *in-house* made motes (i.e. nodes in a wireless sensor network) that operate at lower than usual frequency and therefore consume less power than other, commercially available motes. In addition, they are easier to program which makes communication between chemists and computer scientists easier.

## Development of "solid contact" ISEs

Potentiometric measurements were performed at room temperature (21°C) using a custom-made 4-channel electrode monitor. EMF measurements were conducted in stirring solutions using a Metrohm 728 stir plate and taken against a double junction Ag/AgCl reference electrode (IFS, 3M KCl, Metrohm, 6.0729.100) with 1M LiOAc as bridge electrolyte.

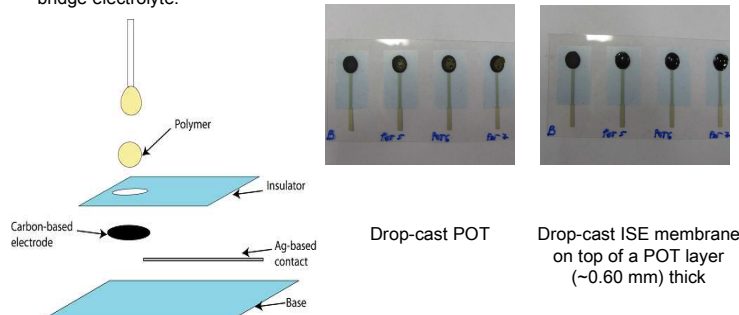

## Solid-state pH electrodes

Composition: 10mmol/kg KTpCITB, 20 mmol/kg H II, PVC:NPOE 1:2

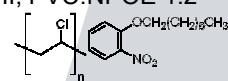
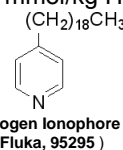
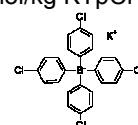

## Experimental data

Comparison of potentiometric measurements obtained with the using a custom-made 4-channel reference system and the *in-house* made motes. Investigation of long-term stability of sensors (top, left); validation of wireless circuitry (top, right); reversibility of response to pH (bottom, left); ■ pH high low; ◆ pH low high; similar experiments performed with wireless mote (bottom, right)

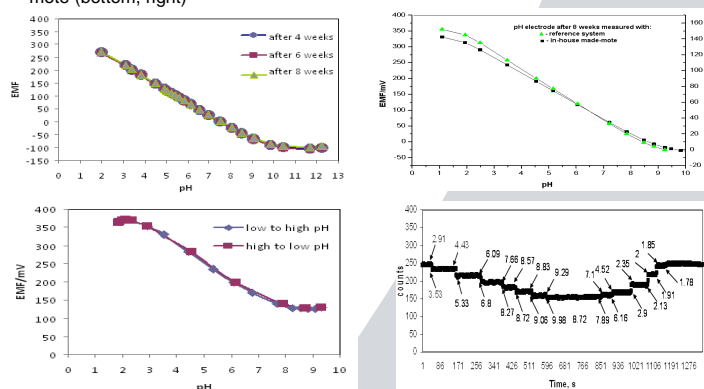

## Development of circuitry for wireless data transmission

A sensor node was constructed on a breadboard to demonstrate the suitability of ISEs for integration in remote sensing devices. The node consists of an In-house made mote called the ConRod, a signal conditioning circuit, and the ISE. Data are transmitted wirelessly to a base station so the data can be stored on a laptop computer. The EMF signal from the ISE has to be conditioned using an instrumentation amplifier due to the requirement of a high impedance input for the data acquisition and the need to adjust the baseline signal to positive voltages for the ADC on the mote.

Measurements with the wireless sensor mote data acquisition system with ability for wireless data transfer adapted for ion-selective electrodes were performed at room temperature (21°C) in parallel using the laboratory reference system, in order to validate the wireless mote circuitry.

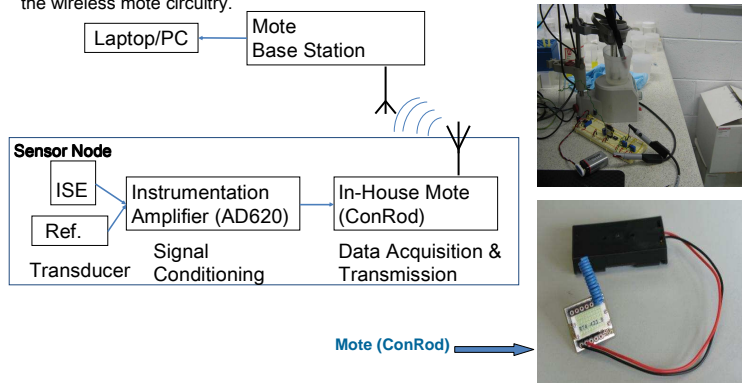

## FUTURE VISION

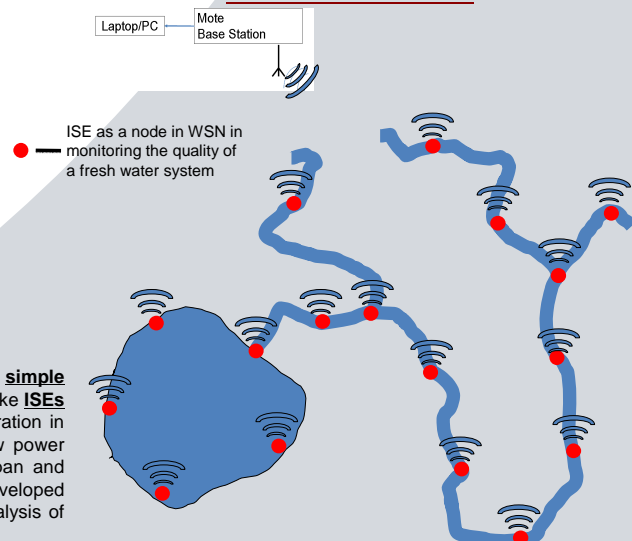

**Conclusions:** A **simple construction**, **good detection limit**, very **low power demand**, and **simple experimental setup** coupled with **miniaturization opportunities** arising from solid-state format make **ISEs excellent prospect for integration in autonomous sensing devices** and ultimately their integration in large wireless sensing networks. The *in-house* mote was used for its low cost construction, low power consumption and simple programming. Hereby developed pH electrode has a wide sensing span and showed excellent reproducibility and repeatability using both classical electronics and the newly developed circuitry for wireless data transmission. Miniaturized ion-selective electrodes can be used for analysis of compounds being relevant for health, environment and clinical analysis.

**Acknowledgement:** Enterprise Ireland grant 07/RFP/MASF812. AR thanks to DCU Research Career Start Fellowship 2008.

This work is supported by Science Foundation Ireland under grant 07/CE/I1147