

The SODA AOSE Methodology

Multiagent Systems LM
Sistemi Multiagente LM

Ambra Molesini & Andrea Omicini
{ambra.molesini, andrea.omicini}@unibo.it

Ingegneria Due
ALMA MATER STUDIORUM—Università di Bologna a Cesena

Academic Year 2011/2012



- 1 SODA: Overview
- 2 SODA: Abstractions
 - A&A in SODA
 - The SODA meta-model
- 3 SODA: Process
 - SPEM
 - The SODA Process Mechanisms
 - The Processes
- 4 SODA: Notation
 - Analysis Phase
 - Design Phase
- 5 Conclusions & Web Resources



SODA: Societies in Open and Distributed Agent spaces

SODA ...

- ... is an agent-oriented methodology for the analysis and design of agent-based systems
- ... focuses on inter-agent issues, like the engineering of societies and environment for MAS [Omicini, 2001]
- ... adopts agents and artifacts – after the A&A meta-model – as the main building blocks for MAS development [Molesini et al., 2005]
- ... introduces a simple *layering* principle in order to cope with the complexity of system description [Molesini et al., 2006]
- ... adopts a tabular representation

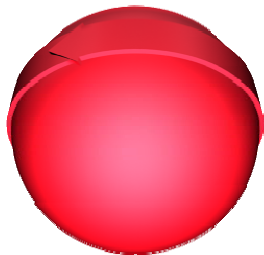

SODA: Overview

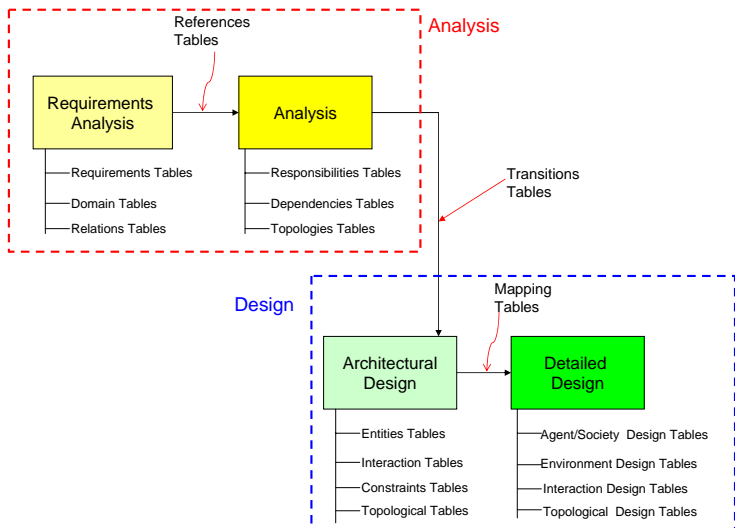

Software Engineering Methodologies: Concerns

Methodology [Ghezzi et al., 2002]

- A methodology is a collection of methods covering and connecting different stages in a process
- The purpose of a methodology is to prescribe a certain coherent approach to solving a problem in the context of a software process by preselecting and putting in relation a number of methods
- A methodology has two important components
 - one that describe the process elements of the approach: the **abstractions**
 - one that focuses on the steps that have to be done, the work products that have to be produced – and their documentation – . . . : the **process**



SODA Abstractions

- The abstractions supported by SODA are logically divided into three categories
 - the abstractions for modelling/designing the system active part (task, role, agent, etc.);
 - the abstractions for the reactive part (function, resource, artifact, etc.);
 - the abstractions for interaction and organisational rules (relation, dependency, interaction, rule, etc.).
- Each of the four SODA's steps models the system by exploiting a specific subset of the abstractions
 - each subset always includes at least one abstraction for each of the above categories: at least one abstraction for the system active part, one for the reactive part, and another for interaction and organisational rules.



SODA Active Abstractions

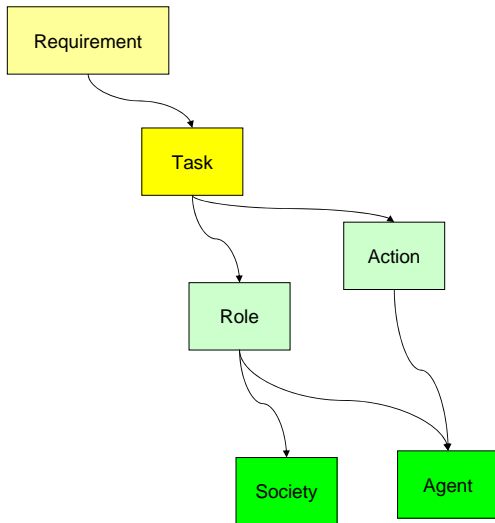

SODA Reactive Abstractions

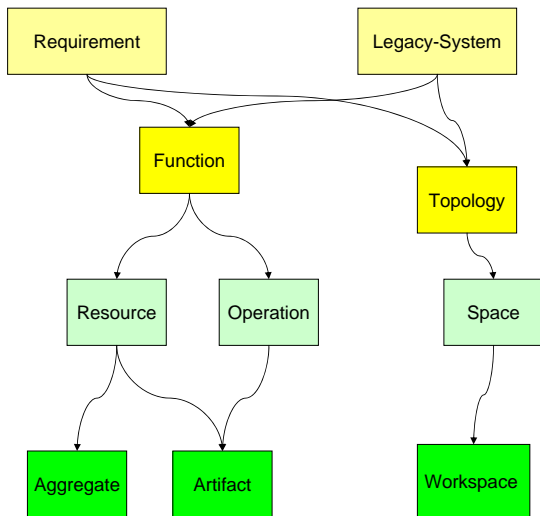

SODA Interaction & Normative Abstractions

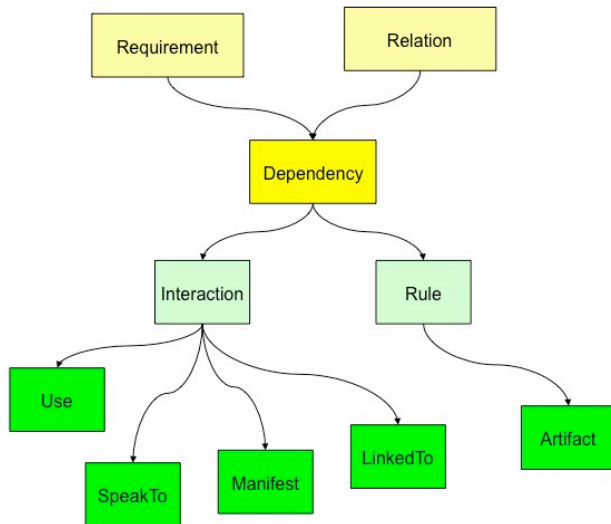

Outline

- 1 SODA: Overview
- 2 SODA: Abstractions**
 - A&A in SODA
 - The SODA meta-model
- 3 SODA: Process
 - SPEM
 - The SODA Process Mechanisms
 - The Processes
- 4 SODA: Notation
 - Analysis Phase
 - Design Phase
- 5 Conclusions & Web Resources



Artifacts

- Artifacts take the form of objects or tools that agents *share* and *use* to
 - support their activities
 - achieve their objectives
- Artifacts are explicitly designed to provide some functions which guide their use by agents

Example: coordination artifacts

- Govern social activities
- Enable and mediate agent interaction
- Mediate the interaction between individual agents and their environment
- Capture, express and embody the parts of the environment that support agents' activities

Classification

A possible classification for artifacts

Individual artifacts — exploited by one agent only in order to mediate its interaction with the environment. In general, individual artifacts are not directly affected by the activity of other agents, but can, through linkability, interact with other artifacts in the MAS

Social artifacts — exploited by more than one agent, mediate between two or more agents in a MAS. In general, social artifacts typically provide MAS with a service which is in the first place meant to achieve a social goal of the MAS, rather than an individual agent goal

Environmental artifacts — mediate between a MAS and an external resource. In principle, environmental artifacts can be conceived as a means to raise external MAS resources up to the agent cognitive level

Agents & Artifacts (A&A)

- Artifacts constitute the basic building blocks both for
 - MAS analysis/modelling
 - MAS development
- Agents and artifacts can be assumed as two fundamental abstractions for modelling MAS structure
 - Agents speaking with other agents
 - Agents using artifacts to achieve their objectives



A&A Ingredients in SODA

Agents model individual and social activities

Artifacts *glue* agents together, as well as MAS and the environment

- artifacts mediate between individual agents and MAS
- artifacts build up agent societies
- artifacts wrap up the resources of MAS and bring them to the cognitive level of agents

Workspaces structure agents and artifacts organisation & interaction



Outline

- 1 SODA: Overview
- 2 SODA: Abstractions**
 - A&A in SODA
 - The SODA meta-model
- 3 SODA: Process
 - SPEM
 - The SODA Process Mechanisms
 - The Processes
- 4 SODA: Notation
 - Analysis Phase
 - Design Phase
- 5 Conclusions & Web Resources



SODA Abstractions: A Formal Representation?

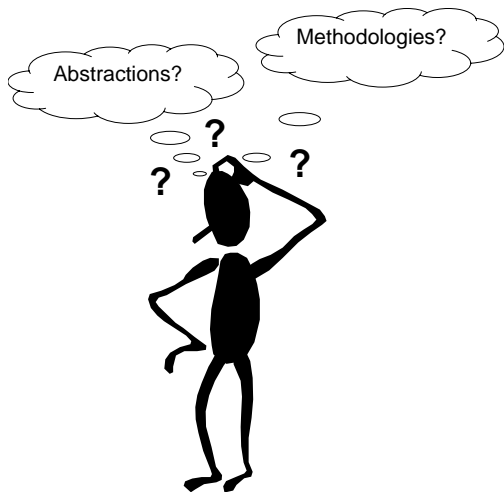

SODA Abstractions: A Formal Representation?

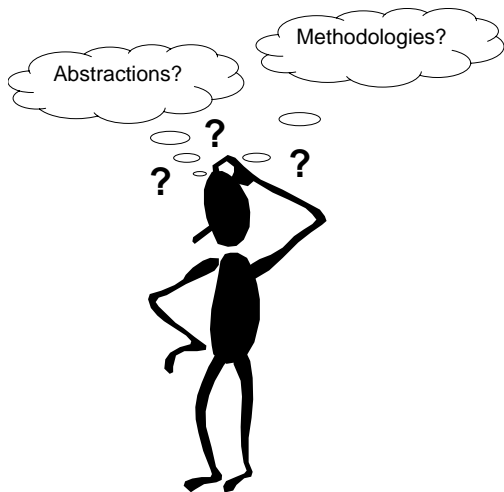

- How can we represent the SODA abstractions? ...



SODA Abstractions: A Formal Representation?

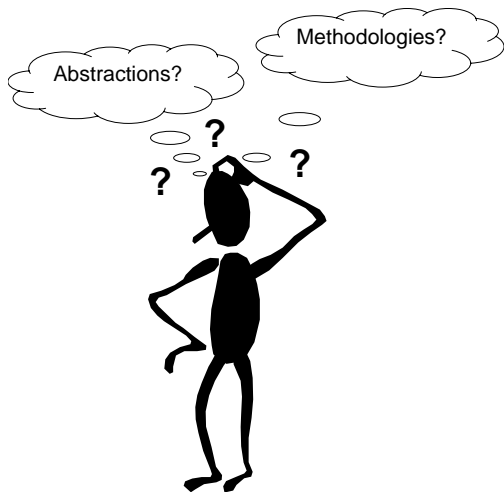

- How can we represent the SODA abstractions? ...
- ...and their relationships? ...



SODA Abstractions: A Formal Representation?

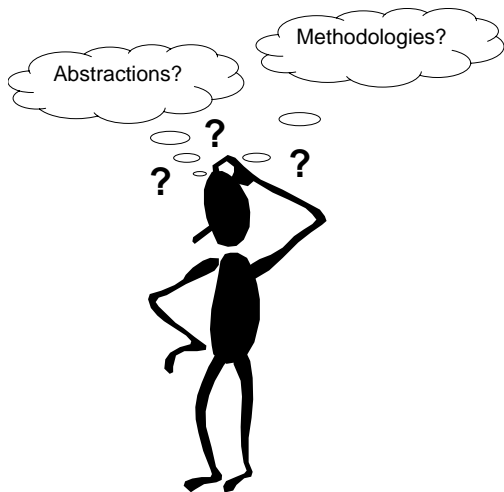

- How can we represent the SODA abstractions? ...
- ...and their relationships? ...
- ...in a standard way in order to support methodologies comparisons? ...



SODA Abstractions: A Formal Representation?

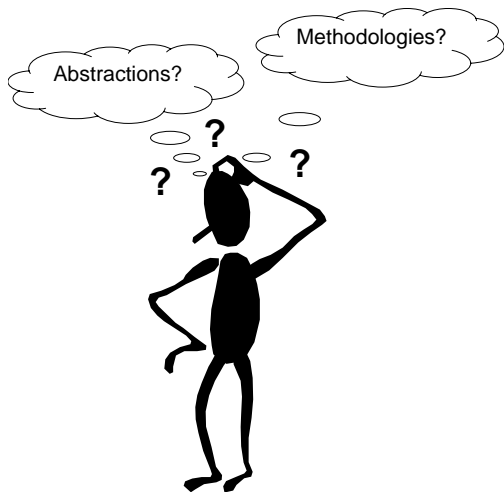

- How can we represent the SODA abstractions? ...
- ...and their relationships? ...
- ...in a standard way in order to support methodologies comparisons? ...
- The meta-modelling technique from Software Engineering can help us



Meta-models for Software Engineering Methodologies

Definition

Meta-modelling is the analysis, construction and development of the frames, rules, constraints, models and theories applicable and useful for the modelling in a predefined class of problems

- A meta-model enables checking and verifying the completeness and expressiveness of a methodology by understanding its deep semantics, as well as the relationships among concepts in different languages or methods
- The process of designing a system consists of instantiating the system meta-model that the designers have in their mind in order to fulfill the specific problem requirements [Bernon et al., 2004]



Using Meta-models

- Meta-models are useful for specifying the concepts, rules and relationships used to define a family of related methodologies
- Although it is possible to describe a methodology without an explicit meta-model, formalising the underpinning ideas of the methodology in question is valuable when checking its consistency or when planning extensions or modifications
- In the specific case of AOSE, the concepts in the meta-model assume the name of MAS Meta-model Elements (MMMEs)



SODA Abstractions Adopted at Each Step

Analysis phase

Requirements Analysis — the system's requirements and the external environment are analysed and modelled

Analysis — the system's requirements are modelled in terms of tasks, functions, topologies and dependencies

Design phase

Architectural Design — in this phase we analyse the solution domain, the system is modelled in terms of roles, resources, actions, operations, interactions, rules and spaces

Detailed Design — in this phase we design the system in terms of agents, societies, artifacts, compositions, aggregates, workspaces, uses, links to, manifests and speaks to

The SODA Meta-model

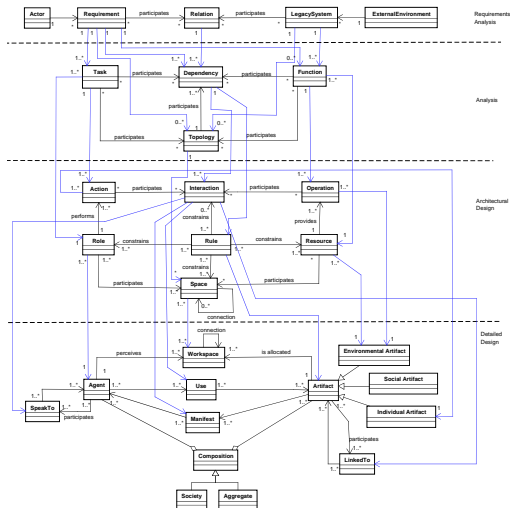

Requirements Analysis Meta-model

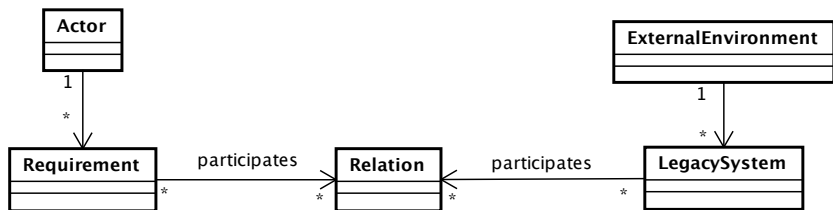

Requirements Analysis

Actor — is a user of the systems that needs several functionalities from the systems. We use the system as an actor in order to express several non-functional requirements as security, standards and so on. The actors are used in order to facilitated the trace of the sources of requirements.

Requirement — is a functional, non-functional or domain description of the system service and constraint of the system.

External-Environment — is the external world of the system made by legacy systems that will interact with the system.

Legacy-System — is a single legacy system.

Relation — is a relationship among requirements and contexts.



Analysis Meta-model

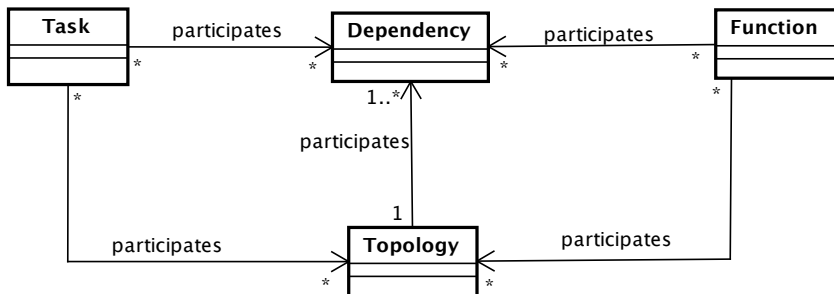

Analysis

Task — is an activity that requires one or more competences and the use of functions

Function — is an reactive activity that aimed at supporting tasks

Dependency — is any relationship (interactions, constraints. . .) among other (tasks and/or functions) abstract entities

Topology — is any topological necessity of the environment's structure, often could be derived from functions. It is important to note that topology could influence the tasks because topology could constrains the achievement of tasks



Architectural Design Meta-model

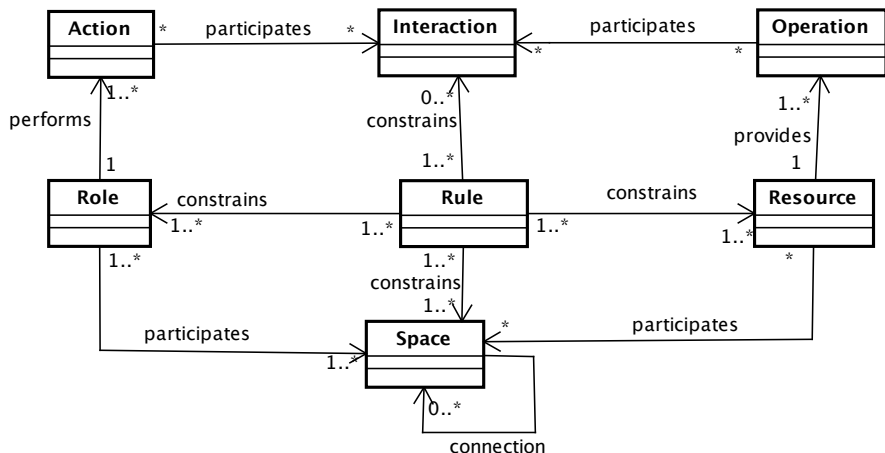

Architectural Design

Role — is defined as the abstraction responsible for the achievement of one or more tasks

Resource — is defined as the abstraction that provides some functions

Action — represents an action that the role potentially could be able to do

Operation — represents the operation that the resource is potentially able to provide

Interaction — represents the acts of the interaction among roles, among resources and between roles and resources

Rule — enables and bounds the entities' behaviour

Space — is a conceptual locus in the environment



Detailed Design Meta-model

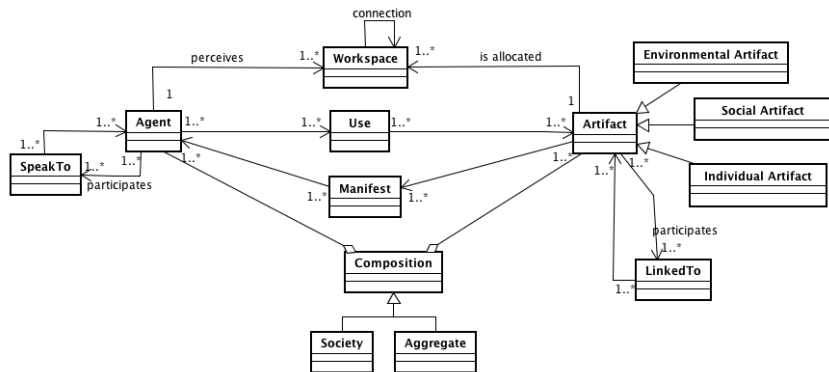

Detailed Design

- Agent** — is an autonomous entity able to play several roles, and perform actions
- Society** — is a group of interacting agents and artifacts whose overall behaviour is essentially an *autonomous*, proactive one
- Artifact** — is a reactive entity able to provide several functions, and make operations available to agents
- Aggregate** — is a group of interacting artifacts and agents whose overall behaviour is essentially a *functional*, reactive one.
- Workspace** — is a conceptual locus in the environment
 - Use** — the act of interaction between agent and artifact: agent uses artifact
 - SpeakTo** — the act of interaction among agents: agent speaks with another agent
 - Manifest** — the act of interaction between artifact and agent: artifact manifests itself to agent
 - LinkedTo** — the act of interaction among artifact: artifact is linked to another artifact



Development Process

Development Process [Cernuzzi et al., 2005]

- The development process is an ordered set of steps that involve all the activities, constraints and resources required to produce a specific desired output satisfying a set of input requirements
- Typically, a process is composed by different stages/phases put in relation with each other
- Each stage/phase of a process identify a portion of work definition to be done in the context of the process, the resources to be exploited to that purpose and the constraints to be obeyed in the execution of the phase
- Case by case, the work in a phase can be very small or more demanding
- Phases are usually composed by a set of activities that may, in turn, be conceived in terms of smaller atomic units of work (steps)

Outline

- 1 SODA: Overview
- 2 SODA: Abstractions
 - A&A in SODA
 - The SODA meta-model
- 3 SODA: Process**
 - SPEM**
 - The SODA Process Mechanisms
 - The Processes
- 4 SODA: Notation
 - Analysis Phase
 - Design Phase
- 5 Conclusions & Web Resources















SPEM

- SPEM (Software Process Engineering Meta-model) [Object Management Group, 2008] is an OMG standard object-oriented meta-model defined as an UML profile and used to describe a concrete software development process or a family of related software development processes
- SPEM is based on the idea that a software development process is a collaboration between active abstract entities called *roles* which perform operations called *activities* on concrete and real entities called *work products*
- Each role interacts or collaborates by exchanging work products and triggering the execution of activities
- The overall goal of a process is to bring a set of work products to a well-defined state



SPEM Notation

Stereotype	Symbol
Activity	
Category	
Composite role and Team	
Guidance	
Milestone	
Process	
Process Component	
Process Pattern	
Role Definition and Use	
Task Definition and Use	
Tool Definition	
WorkProduct Definition and Use	



Outline

- 1 SODA: Overview
- 2 SODA: Abstractions
 - A&A in SODA
 - The SODA meta-model
- 3 SODA: Process**
 - SPEM
 - The SODA Process Mechanisms**
 - The Processes
- 4 SODA: Notation
 - Analysis Phase
 - Design Phase
- 5 Conclusions & Web Resources



Layering: The Intuition

A complex system

is any system featuring a large number of interacting components, whose aggregate activity is nonlinear and typically self-organisation [Simon, 1996].

The human mind

is not able to reason about

- a great number of different components / parts
- too many details...

We need

- models...
- ... capturing the systems' details at different levels of abstraction



Layering: The Intuition

A complex system

is any system featuring a large number of interacting components, whose aggregate activity is nonlinear and typically self-organisation [Simon, 1996].

The human mind

is not able to reason about

- a great number of different components / parts
- too many details. . .

We need

- models. . .
- . . . capturing the systems' details at different levels of abstraction



Layering: The Intuition

A complex system

is any system featuring a large number of interacting components, whose aggregate activity is nonlinear and typically self-organisation [Simon, 1996].

The human mind

is not able to reason about

- a great number of different components / parts
- too many details. . .

We need

- models. . .
- . . . capturing the systems' details at different levels of abstraction



Layering: The Intuition

A complex system

is any system featuring a large number of interacting components, whose aggregate activity is nonlinear and typically self-organisation [Simon, 1996].

The human mind

is not able to reason about

- a great number of different components / parts
- too many details. . .

We need

- models. . .
- . . . capturing the systems' details at different levels of abstraction



Layering: The Intuition

A complex system

is any system featuring a large number of interacting components, whose aggregate activity is nonlinear and typically self-organisation [Simon, 1996].

The human mind

is not able to reason about

- a great number of different components / parts
- too many details. . .

We need

- models. . .
- . . . capturing the systems' details at different levels of abstraction



Layering: The Intuition I



Agent



Layering: The Intuition I

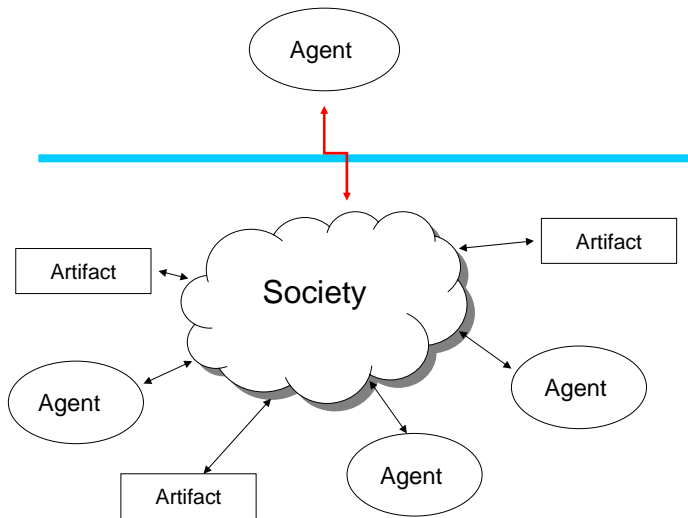

Layering: The Intuition II

Artifact



Layering: The Intuition II

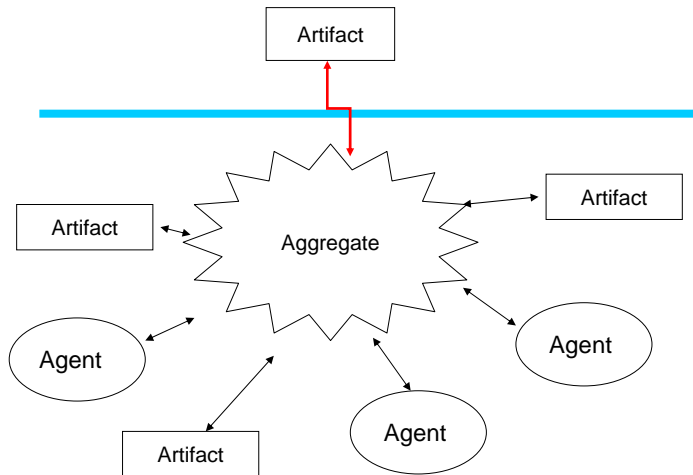

Managing Complexity

- Complexity is inherent in real-life systems
- Complexity management: balancing between *completeness* and *clarity*
- Analysis and design of real-life systems proceed *middle-out*
- Complex systems call for *layered*, hierarchical explanations
- Each layer is in some sense autonomous
 - at the same time, layers are organised in a hierarchy
 - each layer is strictly connected with the upper /lower layers



Layering, Systems & MAS

- In many branches of sciences, systems are represented as organised on different layers
- Each level is essential to the general understanding of the system's wholeness, but at the same time, no level can be understood in isolation
- When applied to the engineering of MAS, this principle suggests
 - that MAS models, abstractions, patterns and technologies can be suitably categorised and compared using a layered description
 - that agent-oriented processes and methods should support some forms of MAS layering



Layering in SODA: The Meta-model

- The layering principle is achieved by means of the **zoom** and **projection** mechanisms [Molesini et al., 2006, Molesini et al., 2010]
- Two kinds of zoom
 - in-zoom** — from an abstract to a more detailed layer
 - out-zoom** — from a detailed to a more abstract layer
- The *projection mechanism* projects entities from one to another layer

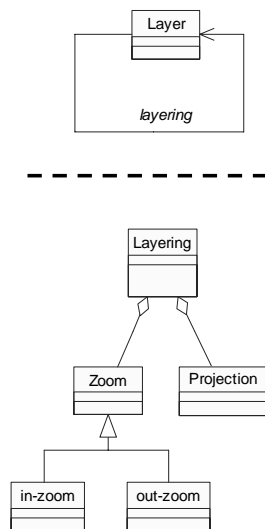

Layering in SODA: Process

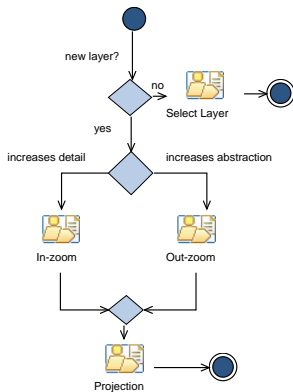

Layering in SODA: Activities, Tasks, Roles and Workproducts

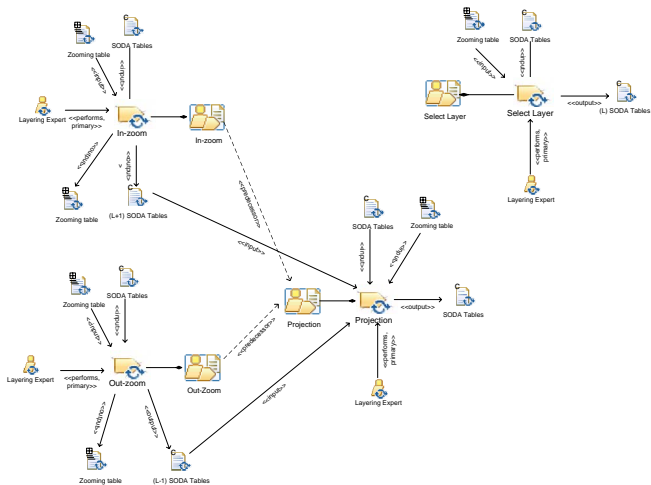

Layering in SODA: Workproducts & MMMEs

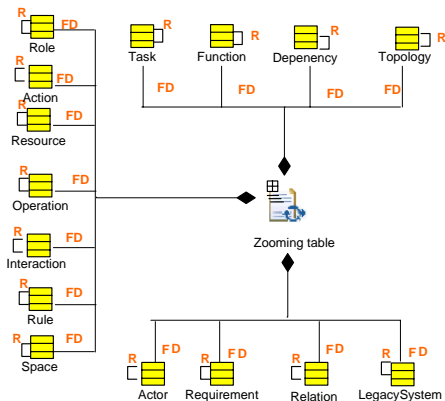

Layering Principle

- In general, when working with SODA, we start from a certain layer, we could call *core layer*, and it is labelled with “c”
- The core layer is always **complete**
- In the other layer we find only the in/out zoomed entities and the projection entities.
- The in-zoomed layers are labelled with “c+1”, “c+2” and the out-zoomed layers are labelled “c-1”, “c-2”...
- The projection entities will be labelled with “+” if the projection is from abstract layer to detailed layer, “-” otherwise
- The only relations between layers are the *zooming relation* express by means of zooming table (in the following)
- If we have relation between entities belonging different layers we have to project these entities in the same layer



Example

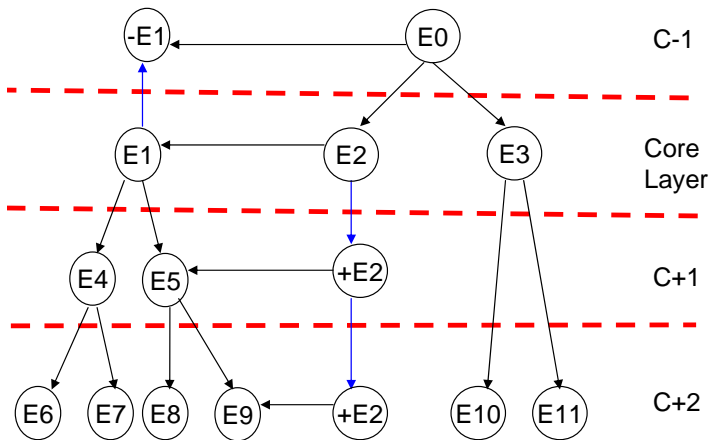

System's Views

Horizontal view: analyse the system in one level of detail

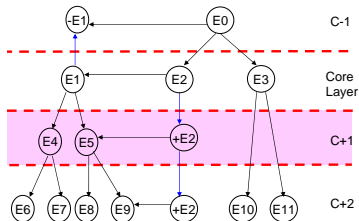

Vertical view: analyse one kind of abstract entity

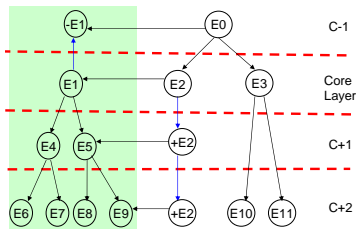

Zooming Artifact 1/2

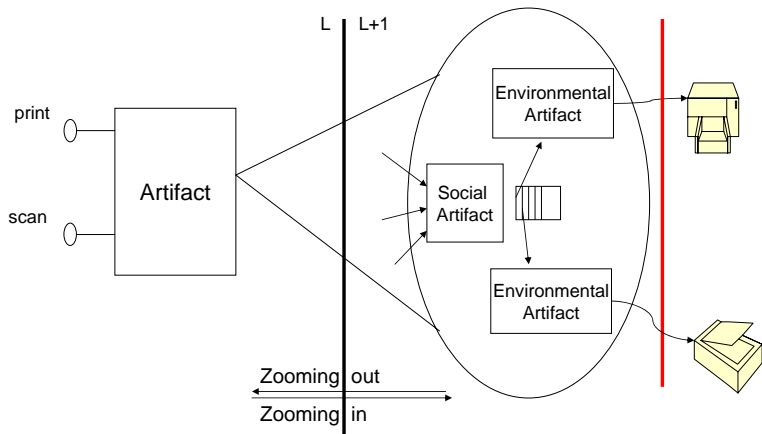

Zooming Artifact 2/2

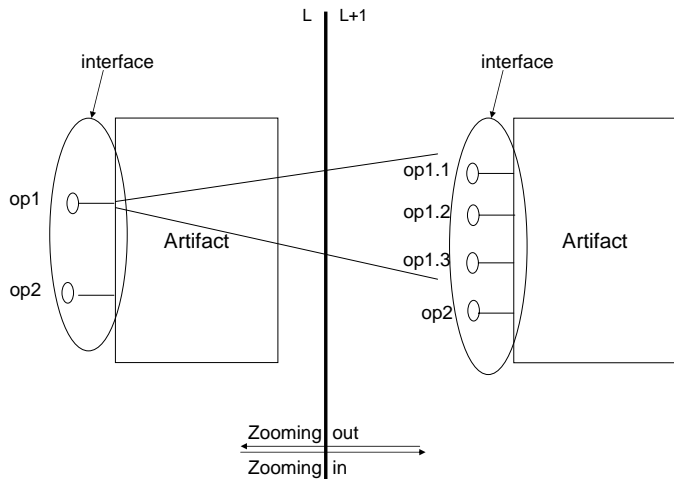

Outline

- 1 SODA: Overview
- 2 SODA: Abstractions
 - A&A in SODA
 - The SODA meta-model
- 3 SODA: Process**
 - SPEM
 - The SODA Process Mechanisms
 - The Processes**
- 4 SODA: Notation
 - Analysis Phase
 - Design Phase
- 5 Conclusions & Web Resources



SODA Process Organisation

- Four sub-phases: Requirements Analysis, Analysis, Architectural Design, Detailed Design
- Each sub-phase is modelled as a separate and independent Method Content
- A specific process is defined for each sub-phase
- Reusing of these processes to create the whole SODA process
- Each sub-phase – and each model in the sub-processes – is represented as an activity, related to the corresponding SPEM's Task(s)
- Adoption of the Layering Capability pattern



The SODA Process [Molesini et al., 2008]

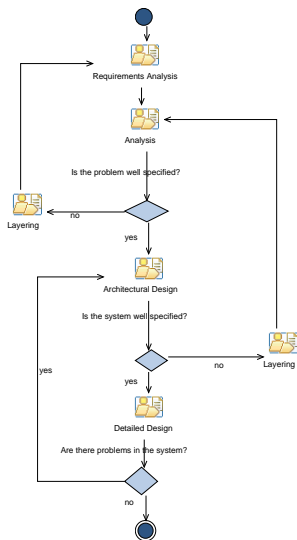

Requirements Analysis Process

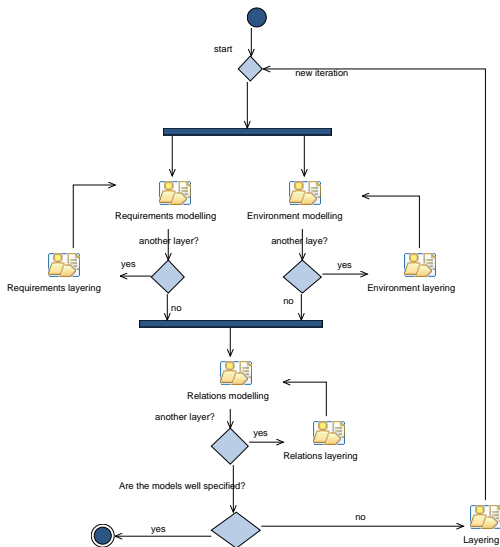

Requirements Analysis Process

Requirements modelling activity: *requirement* and *actor* are used for modelling the customers' requirements and the requirement sources

Environment modelling activity: *external-environment* notion is used as a container of the *legacy-systems* that represent the legacy resources of the environment

Relation modelling activity: *relation* is used for modelling the relationships between requirements and legacy systems



Requirements Analysis: Activities, Tasks, Roles and Workproducts

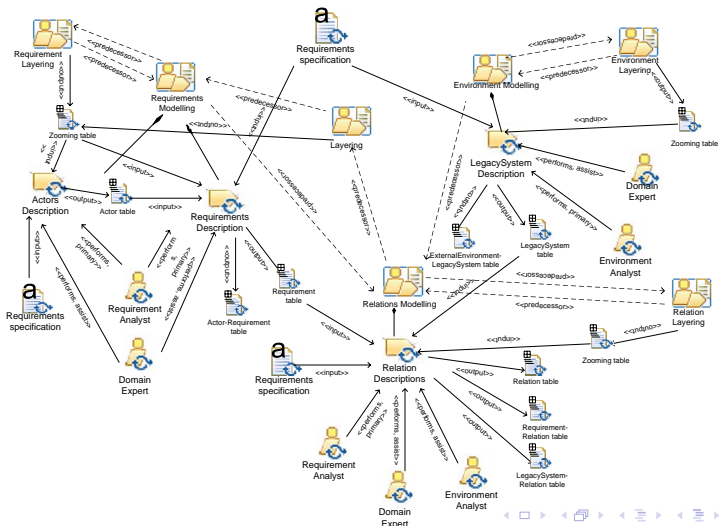

Requirements Analysis: Workproducts & MMEs

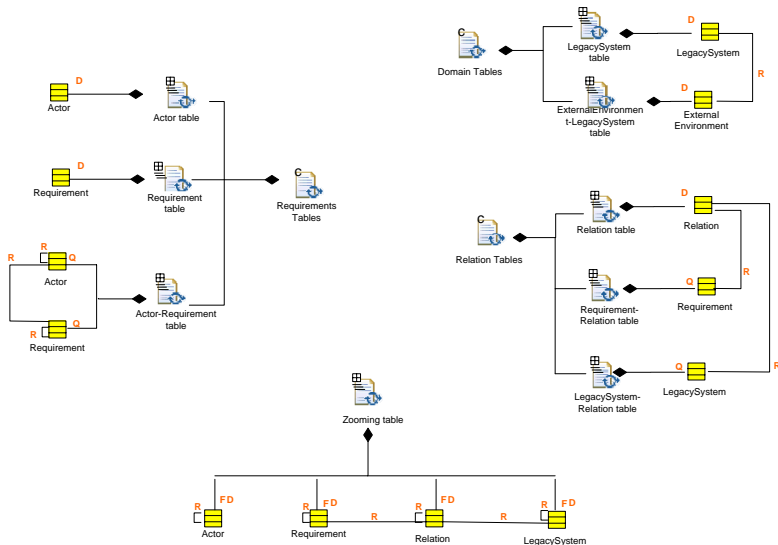

Analysis Process

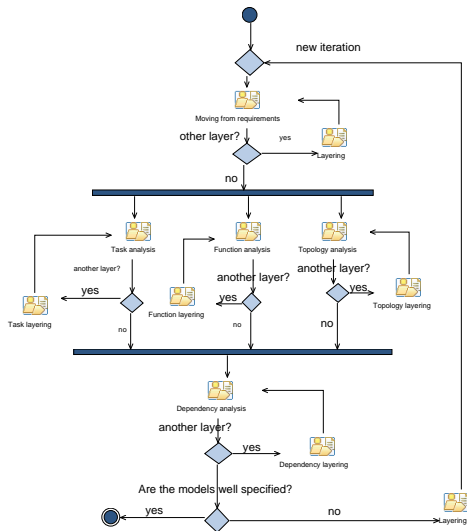

Analysis Process

- Moving from **Requirements** activity: the abstractions identified in the previous step are mapped onto the abstractions adopted in this stage to generate the initial version of the **Analysis models**
- Task analysis** activity: *task* is exploited for analysing the system's active part
- Function analysis** activity: *function* is exploited for analysing the system's functional part
- Topology analysis** activity: *topology* is exploited for analysing the topological constraints over the environment
- Dependency analysis** activity: *dependency* is exploited for the analysis of the relations highlighted in the previous step and for the definition of new relationship among abstract entities identified in this stage



Analysis: Workproducts & MMMEs

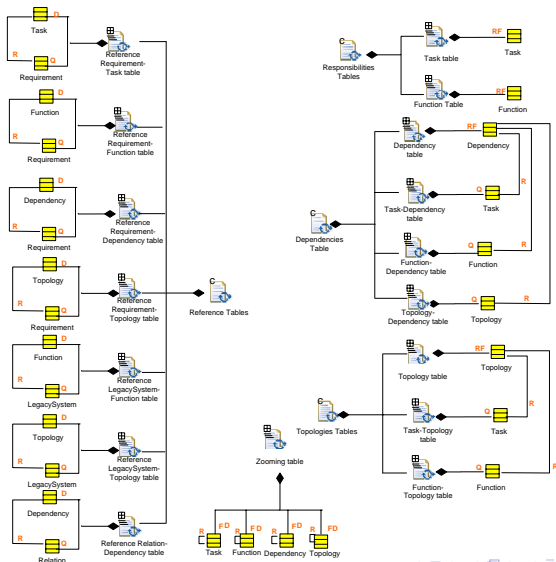

Architectural Design Process

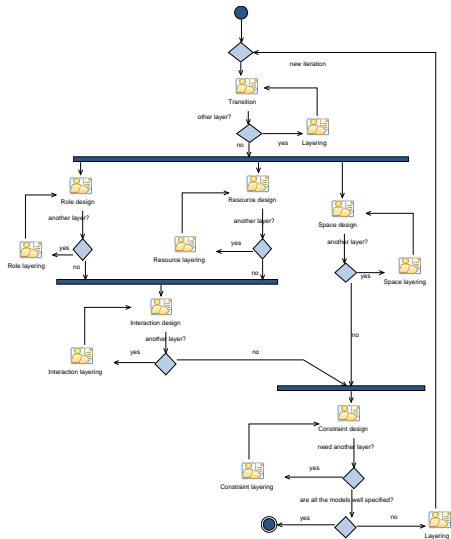

Architectural Design Process

- Transition** activity: the abstractions identified in the previous step are mapped onto the abstractions adopted in this stage so as to generate the initial version of the Architectural Design models
- Role design** activity: assignment tasks to *roles* and identification of the *actions* necessary in order to achieve each specific tasks
- Resource design** activity: assignment of functions of responsibilities for providing to *resources* and identification of the *operations* necessary for providing each specific function.
- Space design** activity: identification of the *spaces* starting from the topology constraints analysed in the previous step
- Interaction design** activity: identification of the *interactions* that represent the acts of the interaction among roles, among resources and between roles and resources starting from the dependencies analysed in the previous step
- Constraint design** activity: identification of the *rules* that enable and bound the entities' behaviour starting from the dependencies analysed in the previous step



Architectural Design: Activities, Tasks, Roles and Workproducts

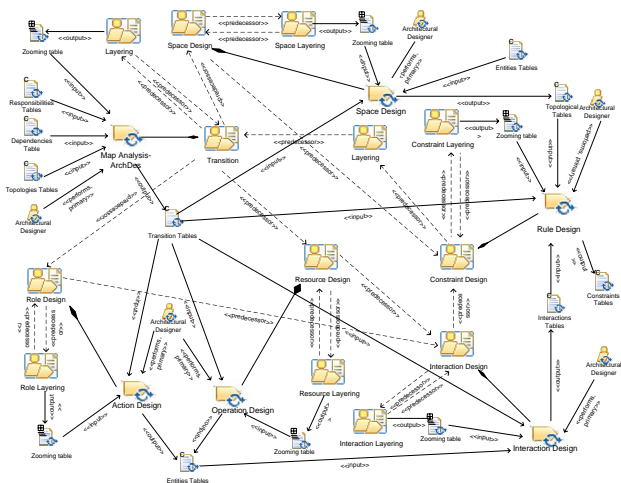

Architectural Design: Workproducts & MMEs

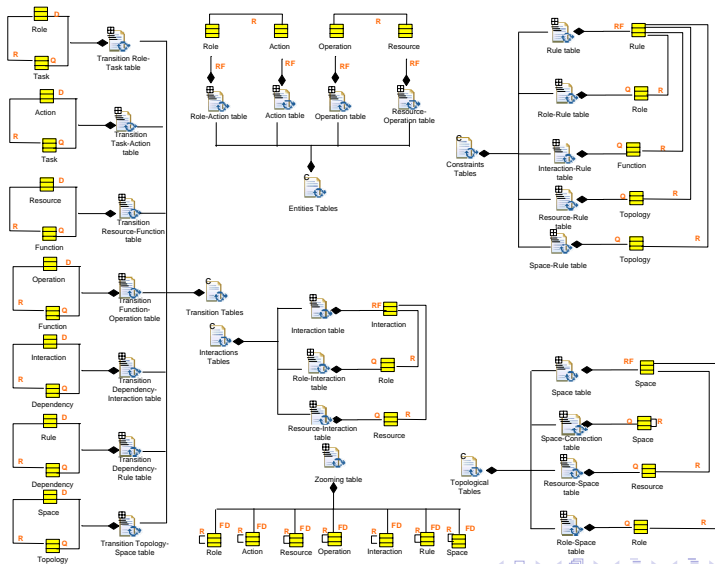

Detailed Design Process

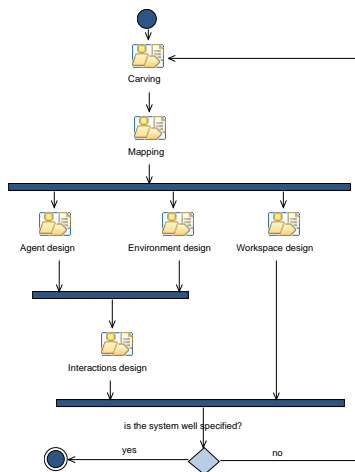

Carving

- In the Architectural Design step our system could be potentially composed by all the layers detected in the previously steps
- Each complete layer represents a different system architecture. . .
- It is not possible to first design and then physically implement a system specified by different levels of abstraction
- So, for each entity, we need to choose the appropriate layer of representation. . .
- ... the chosen system architecture is “carved out” from all the possible architectures
- So, each carving represents a specific development. . .
- ... in an iterative incremental process we can made different carving in order to refine the system



Carving

- In the Architectural Design step our system could be potentially composed by all the layers detected in the previously steps
- Each complete layer represents a different system architecture. . .
- It is not possible to first design and then physically implement a system specified by different levels of abstraction
- So, for each entity, we need to choose the appropriate layer of representation. . .
- ... the chosen system architecture is “carved out” from all the possible architectures
- So, each carving represents a specific development. . .
- ... in an iterative incremental process we can made different carving in order to refine the system



Carving

- In the Architectural Design step our system could be potentially composed by all the layers detected in the previously steps
- Each complete layer represents a different system architecture. . .
- It is not possible to first design and then physically implement a system specified by different levels of abstraction
- So, for each entity, we need to choose the appropriate layer of representation. . .
- ... the chosen system architecture is “carved out” from all the possible architectures
- So, each carving represents a specific development. . .
- ... in an iterative incremental process we can made different carving in order to refine the system



Carving

- In the Architectural Design step our system could be potentially composed by all the layers detected in the previously steps
- Each complete layer represents a different system architecture. . .
- It is not possible to first design and then physically implement a system specified by different levels of abstraction
- So, for each entity, we need to choose the appropriate layer of representation. . .
- ... the chosen system architecture is “carved out” from all the possible architectures
- So, each carving represents a specific development. . .
- ... in an iterative incremental process we can made different carving in order to refine the system



Carving

- In the Architectural Design step our system could be potentially composed by all the layers detected in the previously steps
- Each complete layer represents a different system architecture. . .
- It is not possible to first design and then physically implement a system specified by different levels of abstraction
- So, for each entity, we need to choose the appropriate layer of representation. . .
- ... the chosen system architecture is “carved out” from all the possible architectures
- So, each carving represents a specific development. . .
- ... in an iterative incremental process we can made different carving in order to refine the system



Carving

- In the Architectural Design step our system could be potentially composed by all the layers detected in the previously steps
- Each complete layer represents a different system architecture. . .
- It is not possible to first design and then physically implement a system specified by different levels of abstraction
- So, for each entity, we need to choose the appropriate layer of representation. . .
- ... the chosen system architecture is “carved out” from all the possible architectures
- So, each carving represents a specific development. . .
- ... in an iterative incremental process we can made different carving in order to refine the system



Carving

- In the Architectural Design step our system could be potentially composed by all the layers detected in the previously steps
- Each complete layer represents a different system architecture. . .
- It is not possible to first design and then physically implement a system specified by different levels of abstraction
- So, for each entity, we need to choose the appropriate layer of representation. . .
- ... the chosen system architecture is “carved out” from all the possible architectures
- So, each carving represents a specific development. . .
- ... in an iterative incremental process we can made different carving in order to refine the system



Carving

Architectural Design

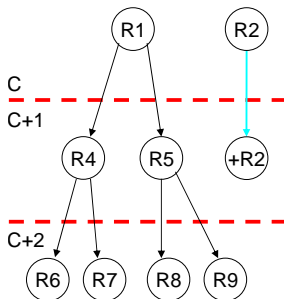

Carving

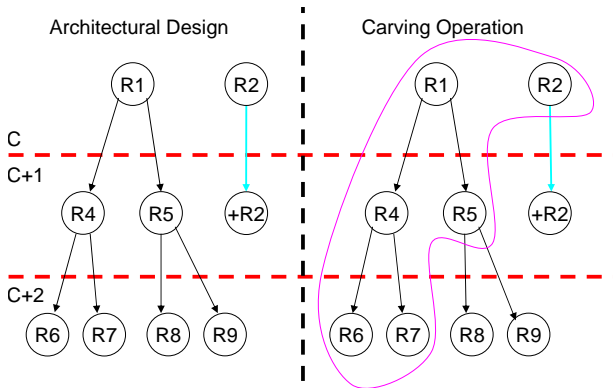

Carving

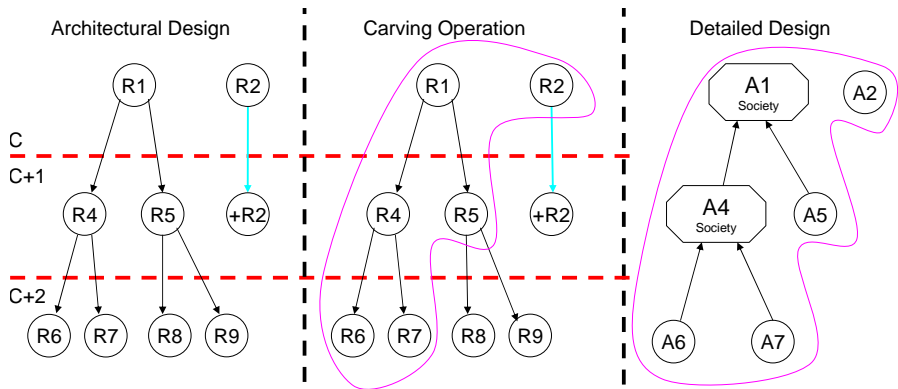

Detailed Design Process

Mapping activity: the carved abstractions are mapped onto the abstractions adopted in this stage, thus generating the initial version of the Detailed Design models

Agent design activity: design of *agents* and *societies*

Environment design activity: design of *artifacts* and *aggregates*

Workspace design activity: design of *workspaces*

Interactions design activity: design of *use*, *manifest*, *speakTo* and *linkedTo*



Detailed Design: Activities, Tasks, Roles and Workproducts

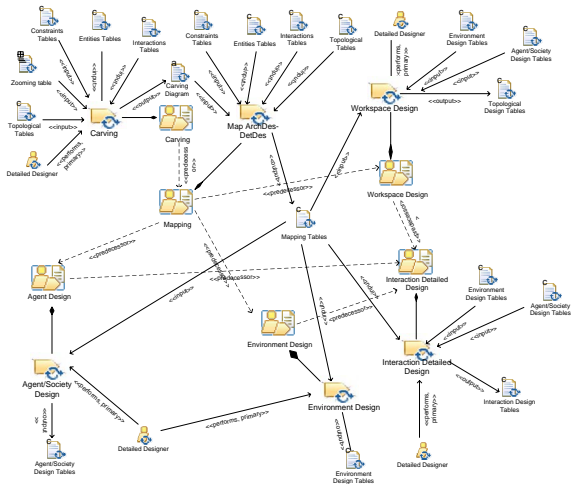

Detailed Design: Workproducts & MMEs

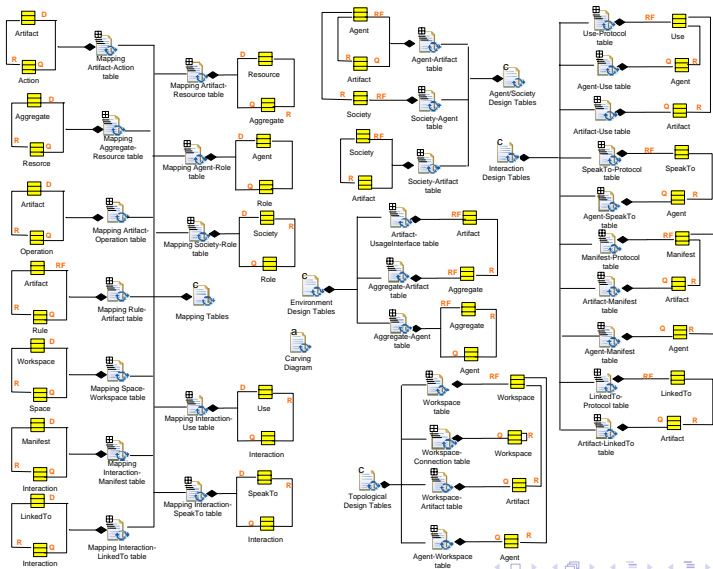

SODA Workproducts Dependencies

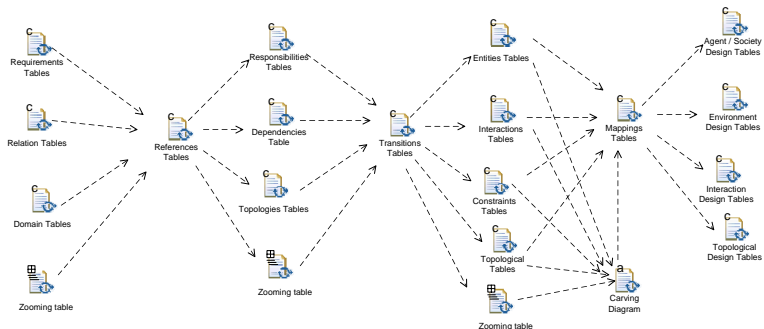

The SODA Notation

The design of a complex system

calls for both a clear and disciplined notation and tools for supporting the consistency checks

- SODA adopts a tabular representation
- Tables
 - clear way for analysing and designing the systems
 - very easy for automatic tools
 - very easy for consistency and completeness checkers



Outline

- 1 SODA: Overview
- 2 SODA: Abstractions
 - A&A in SODA
 - The SODA meta-model
- 3 SODA: Process
 - SPEM
 - The SODA Process Mechanisms
 - The Processes
- 4 SODA: Notation
 - Analysis Phase
 - Design Phase
- 5 Conclusions & Web Resources



Analysis Phase: Tables

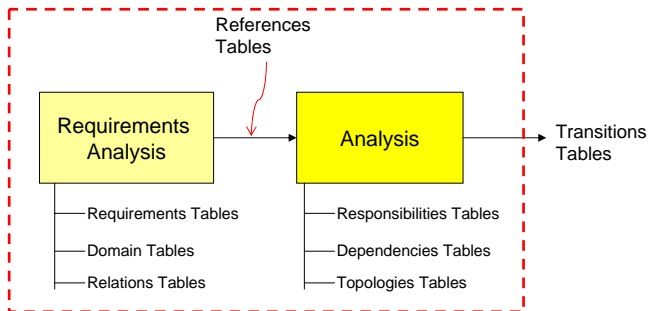

Requirements Analysis: Tabular Representation

- Requirements Tables: $(L)A_{C_t}$, $(L)A_{R_t}$ and $(L)R_{e_t}$

Actor	Description
<i>actor name</i>	<i>actor description</i>
Actor	Requirement
<i>actor name</i>	<i>requirement names</i>
Requirement	Description
<i>requirement name</i>	<i>requirement description</i>

- Domain Tables: $(L)EELS_t$ and $(L)LS_t$

External-Environment	Legacy-System
<i>external-environment name</i>	<i>Legacy-System names</i>
Legacy-System	Description
<i>legacy-system name</i>	<i>legacy-system description</i>



Requirements Analysis: Tabular Representation

- Requirements Tables define and describe the abstract entities tied to the concept of “requirement”
 - *Actor table* $((L)Ac_t)$ describes each single actor
 - *Actor-Requirement Table* $((L)AR_t)$ specifies the list of the requirements for each actors
 - *Requirement Table* $((L)Re_t)$ lists all the requirement and describe them.
- Domain Tables define and describe the abstract entities tied to the external environment
 - *ExternalEnvironment-LegacySystem Table* $((L)EELS_t)$ specifies the list of the contexts for external-environment
 - *Legacy-System Table* $((L)LS_t)$ lists all the contexts and describe them



Requirements Analysis: Tabular Representation

- Relations Tables: $(L)Rel_t$, $(L)RR_t$ and $(L)RLS_t$

Relation	Description
<i>relation name</i>	<i>relation description</i>

Requirement	Relation
<i>requirement name</i>	<i>relation names</i>

Legacy-System	Relation
<i>legacy-system name</i>	<i>relation names</i>



Requirements Analysis: Tabular Representation

- Relations Tables relate the abstract entities among them
 - *Relation Table* $((L)Rel_t)$ lists all the relationship among abstract entities and provides a description to them
 - *Requirement-Relation Table* $((L)RR_t)$ specifies the list of relations where requirement is involved
 - *LegacySystem-Relation Table* $((L)LSR_t)$ specifies the list of relations where context is involved



From Requirements Analysis to Analysis (II)

- References Tables in top- down order: $(L)RRT_t$, $(L)RRF_t$, $(L)RRTot_t$, $(L)RReqD_t$, $(L)RLSF_t$, $(L)RLST_t$, $(L)RReID_t$

Requirement	Task
<i>requirement name</i>	<i>task names</i>
Requirement	Function
<i>requirement name</i>	<i>function names</i>
Requirement	Topology
<i>requirement name</i>	<i>topology names</i>
Requirement	Dependency
<i>requirement name</i>	<i>dependency names</i>
Legacy-System	Function
<i>legacy-system name</i>	<i>function names</i>
Legacy-System	Topology
<i>legacy-system name</i>	<i>topology names</i>
Relation	Dependency
<i>relation name</i>	<i>dependency names</i>



From Requirements Analysis to Analysis (III)

References Tables identify the relations among the abstractions of the requirement analysis phase and the abstractions used in analysis phase.

- *Reference Requirement-Task Table* $((L)RRT_t)$ specifies the mapping between requirement and tasks
- *Reference Requirement-Function Table* $((L)RRF_t)$ specifies the mapping between requirement and resources
- *Reference Requirement-Topology table* $((L)RRTo_t)$ specifies the mapping between each requirement and the generated topologies
- *Reference Requirement-Dependency table* $((L)RReqD_t)$ specifies the mapping between each requirement and the generated dependencies
- *Reference LegacySystem-Function Table* $((L)RLSF_t)$ specifies the mapping between legacy-system and functions
- *Reference LegacySystem-Topology Table* $((L)RLST_t)$ specifies the mapping between legacy-system and topologies
- *Reference Relation-Dependency Table* $((L)RRD_t)$ specifies the mapping between relations and dependencies



Analysis: Tabular Representation

- Responsibilities Tables: $(L)T_t$ and $(L)F_t$

Task	Description
<i>task name</i>	<i>task description</i>

Function	Description
<i>function name</i>	<i>function description</i>

- Dependencies Tables: $(L)D_t$, $(L)TD_t$, $(L)FD_t$ and $(L)TopD_t$

Dependency	Description
<i>dependency name</i>	<i>dependency description</i>

Task	Dependency
<i>task name</i>	<i>dependency names</i>

Function	Dependency
<i>function name</i>	<i>dependency names</i>

Topology	Dependency
<i>topology name</i>	<i>dependency names</i>



Analysis: Tabular Representation

- Responsibilities Tables define and describe the abstract entities tied to the concept of “responsibility”
 - *Task Table* $((L)T_t)$ lists all the tasks and describes them
 - *Function Table* $((L)F_t)$ lists all the functions and describe them
- Dependencies Tables relate the abstract entities among them.
 - *Dependency Table* $((L)D_t)$ lists all the dependency among abstract entities and provides a description to them.
 - *Task-Dependency Table* $((L)TD_t)$ specifies the list of dependencies where task is involved.
 - *Function-Dependency Table* $((L)FD_t)$ specifies the list of dependencies where function is involved.
 - *Topology-Dependency table* $((L)TopD_t)$ specifies the list of dependencies where each topology is involved.



Analysis: Tabular Representation

- Topologies Tables in top-down order – $(L)Top_t$, $(L)TTop_t$, $(L)FTop_t$

Topology	Description
<i>Topology name</i>	<i>topology description</i>
Task	Topology
<i>task name</i>	<i>topology names</i>
Function	Topology
<i>function name</i>	<i>topology names</i>

- Topologies Tables express the topological needs
 - *Topology Table* ($(L)Top_t$) lists all the topological requirements and provides a description to them.
 - *Task-Topology Table* ($(L)TTop_t$) specifies the list of topological requirements those influence the task.
 - *Function-Topology Table* ($(L)FTop_t$) specifies the list of topological requirements affected by the function.



Zooming: Tabular Representation

- Zooming Table: $(L)Z_t$

Layer L	Layer L+1
<i>out-zoomed entity</i>	<i>in-zoomed entities</i>



Example: In-zoom Task

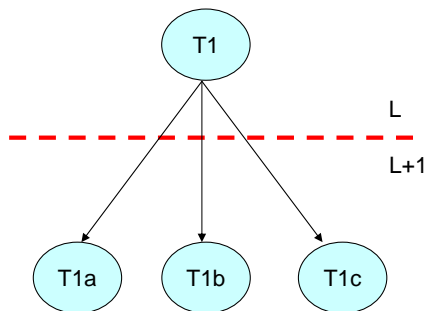

- Zooming Table: $(L)Z_t$

Layer L	Layer L+1
$T1$	$T1a, T1b, T1c, \dots$



Example: Out-zoom Tasks

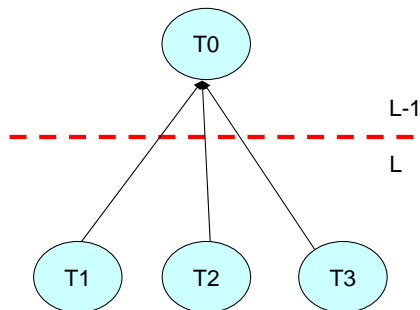

- Zooming Table: $(L)Z_t$

Layer L-1	Layer L
T_0	T_1, T_2, T_3, \dots



Remarks

- The organisational structure of the system is *implicitly managed by means of zooming relation*
- For example when we in-zoom a task, we obtain new tasks, new dependencies and potentially new functions and topologies.
- By means of new dependencies we can express all the social rules that allow to new task to work together to achieve the original tasks.
- In the same way in the architectural design phase when we in-zoom a role, we obtain new roles, new actions, new interactions and potentially new resources and operations. By means of new interactions we can express all the social rules that allow to new roles to work together to achieve the “social task(s)” assigned to the original role.



Complete Example: In-zoom Task

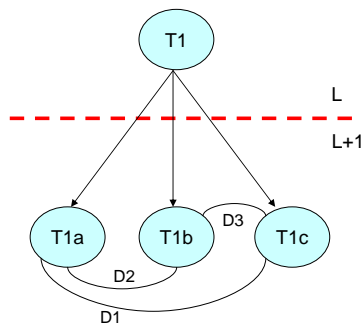

- Zooming Table: $(L)Z_t$

Layer L	Layer L+1
$T1$	$T1a, T1b, T1c$ $D1, D2, D3$



Outline

- 1 SODA: Overview
- 2 SODA: Abstractions
 - A&A in SODA
 - The SODA meta-model
- 3 SODA: Process
 - SPEM
 - The SODA Process Mechanisms
 - The Processes
- 4 SODA: Notation
 - Analysis Phase
 - Design Phase
- 5 Conclusions & Web Resources



Design Phase: Tables

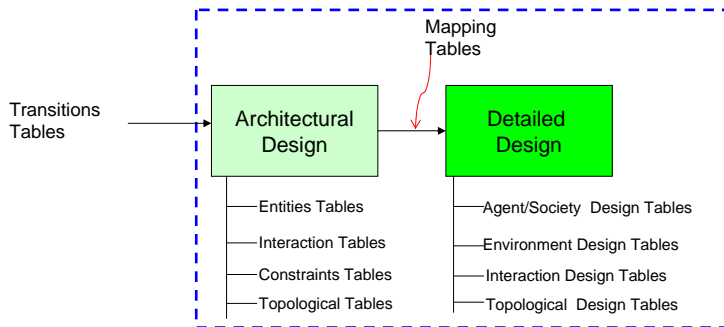

From Analysis to Architectural Design

Transition Tables in top-down order – $(L)TRT_t$, $(L)TTA_t$, $(L)TRF_t$,
 $((L)TFO_t)$, $(L)TID_t$, $(L)TTopS_t$

Role	Task
<i>role name</i>	<i>task names</i>
Task	Action
<i>task name</i>	<i>action names</i>
Resource	Function
<i>resource name</i>	<i>function names</i>
Function	Operation
<i>function name</i>	<i>operation names</i>
Dependency	Interaction
<i>dependency name</i>	<i>interaction names</i>
Dependency	Rule
<i>dependency name</i>	<i>rule names</i>
Topology	Space
<i>topology name</i>	<i>space names</i>



From Analysis to Architectural Design

- Transition Tables identify the relations among the abstractions of the requirement analysis phase and the abstractions used in analysis phase
 - *Transition Role-Task Table* ($((L)TRT_t)$) specifies the mapping between tasks and roles.
 - *Transition Task-Action table* ($((L)TTA_t)$) relates tasks and actions.
 - *Transition Resource-Function Table* ($((L)TRF_t)$) specifies the mapping between functions and resources.
 - *Transition Function-Operation table* ($((L)TFO_t)$) relates functions and operations.
 - *Transition Interaction-Dependency Table* ($((L)TID_t)$) specifies the mapping between dependencies and interaction.
 - *Transition Rule-Dependency table* ($((L)TRuD_t)$) maps dependencies onto rules
 - *Transition Topology-Space Table* ($((L)TTopS_t)$) specifies the mapping between topologies and spaces.



Architectural Design: Tabular Representation

- Entities Tables in top-down order – $(L)A_t$, $(L)O_t$, $(L)RA_t$, $(L)RO_t$

Action	Description
<i>action name</i>	<i>description</i>
Operation	Description
<i>operation name</i>	<i>description</i>
Role	Action
<i>role name</i>	<i>action names</i>
Resource	Operation
<i>resource name</i>	<i>operation names</i>



Architectural Design: Tabular Representation

- The Entities Tables that describe roles and resources of the system
 - *Action Table* $((L)A_t)$ specifies the actions that roles could be able to execute and describes them the mapping between tasks and roles.
 - *Operation Table* $((L)O_t)$ specifies the operations that resources could provide and describes them the mapping between tasks and roles.
 - *Role-Action Table* $((L)RA_t)$ specifies the list of actions that a specific role is able to do.
 - *Resource-Operation Table* $((L)RO_t)$ specifies the list of operations that a specific resource is able to provide.



Architectural Design: Tabular Representation

- Interactions Tables in top-down order – $(L)I_t$, $(L)Acl_t$, $(L)Opl_t$

Interaction	Description
<i>interaction name</i>	<i>description</i>

Action	Interaction
<i>action name</i>	<i>interaction names</i>

Operation	Interaction
<i>operation name</i>	<i>interaction names</i>



Architectural Design: Tabular Representation

- The Interactions Tables that describe the interaction where roles and resources are involved
 - *Interaction Table* $((L)I_t)$ specifies the interactions and describes them. the mapping between tasks and roles.
 - *Action-Interaction table* $((L)Acl_t)$ specifies the interactions where each action is involved.
 - *Operation-Interaction table* $((L)Opl_t)$ specifies the interactions where each operation is involved.



Architectural Design: Tabular Representation

- Constraints Tables in top-down order – $(L)Ru_t$, $(L)IRu_t$, $(L)ReRu_t$, $(L)RoRu_t$, $(L)SRu_t$

Rule	Description
<i>rule name</i>	<i>description</i>

Interaction	Rule
<i>interaction name</i>	<i>rule names</i>

Resource	Rule
<i>resource name</i>	<i>rule names</i>

Role	Rule
<i>role name</i>	<i>rule names</i>

Space	Rule
<i>space name</i>	<i>rule names</i>



Architectural Design: Tabular Representation

- The Constraints Tables describe the constraints over the entities behaviours
 - *Rule table* $((L)Ru_t)$ defines the single rule.
 - *Rule-Interaction table* $((L)IRu_t)$ specifies the constraints over the interactions.
 - *Resource-Rule table* $((L)ReRu_t)$ specifies the rules where each resource is involved.
 - *Role-Rule table* $((L)RoRu_t)$ specifies the rules where each role is involved.
 - *Space-Rule table* $((L)SRu_t)$ specifies the rules where each space is involved.



Architectural Design: Tabular Representation

- Topological Tables in top-down order – $(L)S_t$, $(L)SC_t$, $(L)SRe_t$ and $(L)SRo_t$

Space	Description
<i>space name</i>	<i>description</i>

Space	Connection
<i>space name</i>	<i>space names</i>

Resource	Space
<i>resource name</i>	<i>space names</i>

Role	Space
<i>role name</i>	<i>space names</i>



Architectural Design: Tabular Representation

- Topological Tables

- *Space table* $((L)S_t)$ specifies the spaces and describes them.
- *Space-Connection table* $((L)SC_t)$ shows the connections between spaces at the same layer of abstraction (the hierarchical relations among spaces are managed by means of zooming table)
- *Space-Resource table* $((L)SRe_t)$ shows the allocation of the resources to spaces. A resource could be allocated in several different spaces. In particular, a single, distributed resource can in principle be used to model a distributed service, accessible from more nodes of the network.
- *Space-Role table* $((L)sRo_t)$ shows the list of space that the roles can perceive in the system.



From Architectural Design to Detailed Design

- Mapping Tables in top-down order – MAR_t , MSR_t , $MAAc_t$, MAR_t , $MAGgR_t$, $MAROp_t$, $MARu_t$, MSW_t , MIU_t , MIM_t , $MISp_t$, MIL_t

Agent	Role
<i>agent name</i>	<i>role names</i>

Society	Role
<i>society name</i>	<i>role name</i>

(Individual) Artifact	Action
<i>artifact name</i>	<i>action names</i>

(Environmental) Artifact	Resource
<i>artifact name</i>	<i>resource names</i>

Aggregate	Resource
<i>aggregate name</i>	<i>resource name</i>

(Environmental) Artifact	Operation
<i>artifact name</i>	<i>operation names</i>



From Architectural Design to Detailed Design

Rule	Artifact
<i>rule name</i>	<i>artifact names</i>
Workspace	Space
<i>workspace name</i>	<i>space names</i>
Interaction	Use
<i>interaction name</i>	<i>use names</i>
Interaction	Manifest
<i>interaction name</i>	<i>manifest names</i>
Interaction	SpeakTo
<i>interaction name</i>	<i>speak names</i>
Interaction	LinkedTo
<i>interaction name</i>	<i>linked names</i>



From Architectural Design to Detailed Design I

- Mapping Tables

- *Mapping Agent-Role table (MAR_t)* maps roles onto agents
- *Mapping Society-Role table (MSR_t)* maps role onto society
- *Mapping Artifact-Action table ($MAAc_t$)* maps actions onto individual artifacts
- *Mapping Artifact-Resource table ($MARr_t$)* maps resources onto artifacts
- *Mapping Aggregate-Resource table ($MAggR_t$)* maps resources onto aggregate
- *Mapping Artifact-Operation table ($MAROp_t$)* maps operation onto environmental artifacts
- *Mapping Artifact-Rule table ($MARu_t$)* maps the rules specified in the Architectural Design onto the artifacts that implement and enforce them
- *Mapping Artifact-Operation table (MSW_t)* maps spaces onto workspaces



From Architectural Design to Detailed Design II

- *Mapping Interaction-Use table* (MIU_t) maps interactions onto use
- *Mapping Interaction-Manifest table* (MIM_t) maps interactions onto manifest
- *Mapping Interaction-SpeakTo table* ($MISp_t$) maps interactions onto SpeakTo
- *Mapping Interaction-LinkedTo table* (MIL_t) maps interactions onto linkedTo



Detailed Design: Tabular Representation

- Agent/Society Design Tables in top-down order – $(L)AA_t$, $(L)SA_t$, $(L)SAr_t$

Agent	(Individual) Artifact
<i>agent name</i>	<i>artifact names</i>

Society	Agent
<i>Society name</i>	<i>agent names</i>

Society	Artifact
<i>society name</i>	<i>artifact names</i>



Detailed Design: Tabular Representation

- Agent/Society Design Tables
 - *Agent-Artifact Table* $((L)AA_t)$ specifies the (individual) artifacts related to agents.
 - *Society-Agent Table* $((L)SA_t)$ specifies which agents work in the society
 - *Society-Artifact Table* $((L)SAr_t)$ specifies the artifacts related to societies.



Detailed Design: Tabular Representation

- Environment Design Tables in top-down order – AUI_t , $AggArt_t$, $AggAge_t$

Artifact	Usage Interface
<i>artifact name</i>	<i>list of operations</i>

Aggregate	Artifact
<i>aggregate name</i>	<i>artifact names</i>

Aggregate	Agent
<i>aggregate name</i>	<i>agent names</i>



Detailed Design: Tabular Representation

- Environment Design Tables
 - *Artifact-UsageInterface Table* ($(L)AUI_t$) specifies the operations provided by artifacts.
 - *Aggregate-Artifact table* ($AggArt_t$) lists the artifacts belonging to a specific aggregate.
 - *Aggregate-Agent table* ($AggAge_t$) lists the agents belonging to a specific aggregate



Detailed Design: Tabular Representation

- Interaction Design Tables in top-down order – UP_t , $AgeU_t$, $ArtU_t$, SP_t , $AgeSp_t$, MP_t , $ArtM_t$, $AgeM_t$, LP_t , $ArtL_t$

Use	Protocol
<i>use name</i>	<i>protocol description</i>

Agent	Use
<i>agent name</i>	<i>use names</i>

Artifact	Use
<i>artifact name</i>	<i>use names</i>

SpeakTo	Protocol
<i>speak name</i>	<i>protocol description</i>

Agent	SpeakTo
<i>agent name</i>	<i>speak names</i>

Manifest	Protocol
<i>speak name</i>	<i>protocol description</i>

Artifact	Manifest
<i>artifact name</i>	<i>manifest names</i>

Agent	Manifest
<i>artifact name</i>	<i>manifest names</i>

LinkedTo	Protocol
<i>linked name</i>	<i>protocol description</i>

Artifact	LinkedTo
<i>artifact name</i>	<i>linked names</i>



Detailed Design: Tabular Representation

- Interaction Design Tables concern the design of interactions among entities
 - *Use-Protocol table* (UP_t) details the protocols for each “use” interaction
 - *Agent-Use table* ($AgeU_t$) specifies the “use” where each agent is involved
 - *Artifact-Use table* ($ArtU_t$) specifies the “use” where each artifact is involved
 - *SpeakTo-Protocol table* (SP_t) details the protocols for each “speakTo” interaction
 - *Agent-SpeakTo table* ($AgeSp_t$) specifies the “speakTo” where each agent is involved
 - *Manifest-Protocol table* (MP_t) details the protocols for each “manifest” interaction
 - *Artifact-Manifest table* ($ArtM_t$) specifies the “manifest” where each artifact is involved
 - *Agent-Manifest table* ($AgeM_t$) specifies the “manifest” where each agent is involved
 - *LinkedTo-Protocol table* (LP_t) details the protocols for each “linkedTo” interaction
 - *Artifact-LinkedTo-table* ($ArtL_t$) specifies the “linkedTo” where each artifact is involved



Detailed Design: Tabular Representation

- Topological Design Tables in top-down order: $(L)W_t$, $(L)WC_t$, $(L)WArt_t$ and $(L)WA_t$

Workspace	Description
<i>workspace name</i>	<i>description</i>

Workspace	Connection
<i>workspace name</i>	<i>workspace names</i>

Workspace	Artifact
<i>workspace name</i>	<i>artifact names</i>

Agent	Workspace
<i>agent name</i>	<i>workspace names</i>



Detailed Design: Tabular Representation

- Topological Design Tables describe the structure of the environment:
 - *Workspace table* $((L)W_t)$ describes the workspaces
 - *Workspace-Connection table* $((L)WC_t)$ shows the connections among the workspaces
 - *Workspace-Artifact table* $((L)WArt_t)$ shows the allocation of the artifacts to workspaces
 - *Workspace-Agent table* $((L)WA_t)$ lists the workspaces that each agent can perceive



Conclusions & Future Work

- SODA allows engineers to
 - design societies
 - design environments
 - support the complexity of system description (layering principle)
- Future works
 - testing SODA
 - refining the meta-model
 - building the tools
 - extracting fragments from SODA according to IEEE-FIPA Method Engineering
 - integration between methodologies' and infrastructures' processes



Web Site

`http://soda.apice.unibo.it`

SODA Space

ALMA MATER STUDIUM BOLOGNENSE UNIVERSITÀ DI BOLOGNA SEDE DI CESENA

APICe
DEIS - ELETTRONICA INFORMATICA E SISTEMISTICA

Log-in
En

SODA: Home

SODA

- Home
- Overview
- Publications
- Documents
- People
- Related Projects
- Theses
- Blog

SODA Home

SODA (Societies in Open and Distributed Agent spaces) is a methodology for the analysis and design of complex agent-based systems. SODA is not concerned with *intra-agent issues*: designing a multi-agent system with SODA leads to defining agents in terms of their required observable behaviour and their role in the multi-agent system. Instead, SODA concentrated on *inter-agent issues*, like the engineering of societies and infrastructures for multi-agent systems. Recently a new and extended version of the methodology has been proposed, which takes into account both the Agents and Artifacts (A&A) meta-model, and a mechanism to manage the complexity of system description.

APICe Main Spaces

- Home
- People
- Publications
- Talks
- Projects
- Courses
- Theses
- Themes
- Blog

VALIDATE: XHTML • CSS

PRINTABLE VERSIONS: Preview • PDF • RTF

unibo.it

COPYRIGHT © 2008 ALICE RESEARCH GROUP @ DEIS



- 1 SODA: Overview
- 2 SODA: Abstractions
 - A&A in SODA
 - The SODA meta-model
- 3 SODA: Process
 - SPEM
 - The SODA Process Mechanisms
 - The Processes
- 4 SODA: Notation
 - Analysis Phase
 - Design Phase
- 5 Conclusions & Web Resources



Bibliography I

-  Bernon, C., Cossentino, M., Gleizes, M. P., Turci, P., and Zambonelli, F. (2004).

A study of some multi-agent meta-models.

In Odell, J., Giorgini, P., and Müller, J. P., editors, *Agent-Oriented Software Engineering V*, volume 3382 of *Lecture Notes in Computer Science*, pages 62–77. Springer.

5th International Workshop (AOSE 2004), New York, NY, USA, 19 July 2004. Revised Selected Papers.



-  Cernuzzi, L., Cossentino, M., and Zambonelli, F. (2005).

Process models for agent-based development.

Engineering Applications of Artificial Intelligence, 18(2):205–222.



Bibliography II

-  Ghezzi, C., Jazayeri, M., and Mandrioli, D. (2002).
Fundamental of Software Engineering.
Prentice Hall, second edition.
-  Molesini, A., Denti, E., and Omicini, A. (2005).
MAS meta-models on test: UML vs. OPM in the SODA case study.
In Pěchouček, M., Petta, P., and Varga, L. Z., editors, *Multi-Agent Systems and Applications IV*, volume 3690 of *LNAI*, pages 163–172.
Springer.
4th International Central and Eastern European Conference on
Multi-Agent Systems (CEEMAS'05), Budapest, Hungary,
15–17 September 2005, Proceedings.



Bibliography III

 Molesini, A., Denti, E., and Omicini, A. (2010).

Agent-based conference management: A case study in SODA.
International Journal of Agent-Oriented Software Engineering,
4(1):1–31.

 Molesini, A., Nardini, E., Denti, E., and Omicini, A. (2008).

Advancing object-oriented standards toward agent-oriented
methodologies: SPEM 2.0 on SODA.

In Baldoni, M., Cossentino, M., De Paoli, F., and Seidita, V., editors,
*9th Workshop “From Objects to Agents” (WOA 2008) – Evolution of
Agent Development: Methodologies, Tools, Platforms and Languages*,
pages 108–114, Palermo, Italy. Seneca Edizioni.



Bibliography IV



Molesini, A., Omicini, A., Ricci, A., and Denti, E. (2006).

Zooming multi-agent systems.

In Müller, J. P. and Zambonelli, F., editors, *Agent-Oriented Software Engineering VI*, volume 3950 of *LNCS*, pages 81–93. Springer.

6th International Workshop (AOSE 2005), Utrecht, The Netherlands, 25–26 July 2005. Revised and Invited Papers.



Object Management Group (2008).

Software & Systems Process Engineering Meta-Model Specification 2.0.

<http://www.omg.org/spec/SPEM/2.0/PDF>.



Bibliography V



Omicini, A. (2001).

SODA: Societies and infrastructures in the analysis and design of agent-based systems.

In Ciancarini, P. and Wooldridge, M. J., editors, *Agent-Oriented Software Engineering*, volume 1957 of *LNCS*, pages 185–193.

Springer-Verlag.

1st International Workshop (AOSE 2000), Limerick, Ireland, 10 June 2000. Revised Papers.



Simon, H. A. (1996).

The Sciences of the Artificial.

The MIT Press, 3rd edition.



The SODA AOSE Methodology

Multiagent Systems LM
Sistemi Multiagente LM

Ambra Molesini & Andrea Omicini
{ambra.molesini, andrea.omicini}@unibo.it

Ingegneria Due
ALMA MATER STUDIORUM—Università di Bologna a Cesena

Academic Year 2011/2012

