

IAC-10-D2.4.06

# SpaceLiner Rocket-Powered High-Speed Passenger Transportation Concept Evolving in FAST20XX

*Martin Sippel, Arnold van Foreest*

[Martin.Sippel@dlr.de](mailto:Martin.Sippel@dlr.de) Tel. +49-421-24420145, Fax. +49-421-24420150

*Space Launcher Systems Analysis (SART), DLR, Bremen,, Germany*

The revolutionary ultrafast passenger transport SpaceLiner is under investigation at DLR since more than 5 years. The two-stage, fully reusable vehicle is powered by rocket engines. The EU-funded study FAST20XX (Future high-Altitude high-Speed Transport 20XX) recently set off further deepening the research in this advanced transportation concept.

The paper describes the latest progress of the SpaceLiner configuration achieved in the last two years:

- Vehicle trade-off studies including the choice of propellant (RP vs. LH2) and
  - staging characteristics (e.g. the challenges of single stage concepts for shorter distances)
- Pre-development of a passenger rescue capsule
- Aerodynamic shape refinement
- Resizing and optimization of the passenger stage including establishing a preliminary structural concept

## Nomenclature

D	Drag	N
$I_{sp}$	(mass) specific Impulse	s (N s / kg)
L	Lift	N
M	Mach-number	-
T	Thrust	N
W	weight	N
g	gravity acceleration	m/s <sup>2</sup>
m	mass	kg
q	dynamic pressure	Pa
v	velocity	m/s
$\alpha$	angle of attack	-
$\gamma$	flight path angle	-

## Subscripts, Abbreviations

AOA	Angle of Attack
CMC	Ceramic Matrix Composites
EASA	European Aviation Safety Agency
FAA	Federal Aviation Administration
GLOW	Gross Lift-Off Mass
LEO	Low Earth Orbit
LFBB	Liquid Fly-Back Booster
LH2	Liquid Hydrogen
LOX	Liquid Oxygen
MECO	Main Engine Cut Off
PEEK	Poly-ether-ether ketone
RLV	Reusable Launch Vehicle
SSME	Space Shuttle Main Engine
SSTO	Single Stage to Orbit
TPS	Thermal Protection System
TSTO	Two Stage to Orbit
cog	center of gravity
cop	center of pressure

## 1 INTRODUCTION

A strategic vision has been proposed by DLR in 2005 which ultimately has the potential to enable sustainable low-cost space transportation to orbit (references 1, 2, 3). The baseline idea is simple and quite conventional: Strongly surging the number of launches per year and hence dramatically shrinking manufacturing and operating cost of launcher hardware.

The obvious challenge of the vision is to identify the very application creating this new, large-size market. All recent assessments of the launch business are sobering. The required new market must be significantly different from today's orbiting of communication or earth observation satellites because almost no growth is to be expected in these conventional application areas.

Nevertheless, a market well beyond those assessments could be created if the conventional thinking of what rocket propelled vehicles are to be used for is exceeded.

Ultra fast transportation, much faster than supersonic and even potential hypersonic airplanes, is definitely a fundamental new application for launch vehicles. Even in the case that only a very small portion of the upper business travel segment could be tapped by rocket-propelled means of intercontinental passenger transport, the resulting launch rates per year would be far in excess of any other credible scenario. By no more than partially tapping the huge intercontinental travel and tourist market, production rates of RLVs and their rocket engines could increase hundredfold which is out of reach for all other known earth-orbit space transportation applications. The fast intercontinental travel form of space tourism, not only attracting the leisure market, would, as a byproduct, enable to also considerably reduce the cost of space transportation to orbit.



**Figure 1: The SpaceLiner vision of a rocket-propelled intercontinental passenger transport, shown here at stage separation in a video animation, could push spaceflight further than any other credible scenario**

## 2 STRATEGIC VISION AND REQUIREMENTS OF SPACELINER DEVELOPMENT

Currently, the worldwide launcher sector, including research and industry, remains in a situation of crisis.

An assessment of the launch business already including some kind of optimism is sobering. The Futron *Analysis of Space Concepts Enabled by New Transportation (ASCENT) Study* [4] was carried out in 2002 by NASA Marshall Space Flight Center (MSFC) and Futron Corporation to ‘provide the best possible estimates of global launch vehicle demand for the next twenty years’. The ASCENT study prognosis of an almost flat launch demand in the next 15 to 20 years (Figure 2) already contains new emerging applications. Without the launch demand generated by these new businesses, (notably public space travel), there would be a rather rapid decline of the launch industry during the forecast period.

Figure 2 shows that even the most optimistic “Robust” scenario would only see a slight increase in the number of launches until 2021. Recent retrospect of the past years sadly demonstrated that the “Constrained” lower end of the prognosis was often still too optimistic. The actual number of launch attempts to orbit in *every year* up to 2006 remained *below* even the most pessimistic prognosis as shown in Figure 2. In 2007, for the first time, the actual development slightly exceeded the most pessimistic “Constrained” forecast and in 2009 even slightly exceeded the “Baseline” scenario.

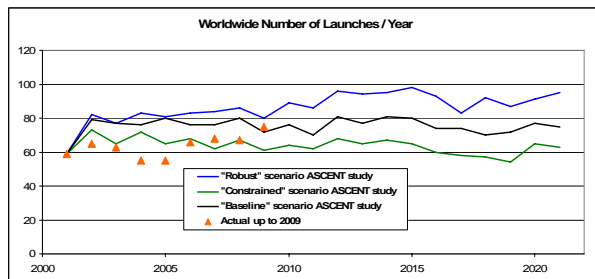

**Figure 2: Baseline, Robust and Constrained forecasts of worldwide number of launches per year for different ASCENT study [4] scenarios compared with actual number of launches**

However, this recent development is unlikely to indicate a turning point or a future surge in launch numbers. The

last year saw different new entrants to the launcher business with several test flights. Iran and the two Koreas attempted payload delivery to orbit. The latter failed and are not included in the statistics of Figure 2.

Thus, the launch history during the last 8 years demonstrates that without new applications the “Constrained” prognosis of ASCENT represents a guideline for the currently achievable yearly launch numbers. A new market with an ability to change the situation, however, must be significantly different from today’s orbiting of communication or earth observation satellites because almost no growth is to be expected in these areas. As has been demonstrated by the ASCENT study, “most of today’s markets, both commercial and governmental, are virtually unaffected by even massive reductions in launch prices.” [4]

Thus, technological progress in space transportation is slowing or stopping because of the decline in launcher development budgets. Space-X’s Falcon family is a low-tech approach and its commercial viability is still to be proven because today’s market conditions are exactly the same as analyzed in ASCENT. (See also [6]!)

The new idea of space tourism as a potential commercial application of spaceflight is gaining momentum and dedicated conferences are held [5]. It has been demonstrated in references 1, 2, and 3 by a first assessment of the SpaceLiner’s potential business case that ultra fast transportation far in excess of supersonic and even potential hypersonic airplanes is such a fundamental new application for launch vehicles. Even in the case that only a very small portion of the upper business travel segment could be tapped by a rocket-propelled intercontinental passenger transport, the resulting launch rates per year would be far in excess of any other credible scenario. The fast intercontinental travel space tourism, not only attracting the leisure market, would, as a byproduct, also enable to considerably reduce the cost of space transportation to orbit.

## 3 THE EU-FUNDED RESEARCH PROJECT FAST20XX

The EU’s 7<sup>th</sup> Framework Program funded FAST20XX (Future high-Altitude high-Speed Transport 20XX) multinational collaborative research project aims at providing a sound technological foundation for the industrial introduction of advanced high-altitude high-speed transportation in the medium term and in the longer term (SpaceLiner application) [13]. Note that no detailed vehicle design is planned in the study but the mastering of technologies required for any later development. The identified critical technologies will be investigated in depth by developing and applying dedicated analytical, numerical and experimental tools, while the legal/regulatory issues will be discussed with government or international authorities.

The high-energy concept SpaceLiner is intended to achieve a step change in ultra-fast long-haul passenger and freight transport. Although the basic performance data of the vertically launching and horizontally landing two-stage vehicle are undisputable, the eventual commercial realization is facing quite a lot of technical

and operational challenges. The most important challenges are:

- High reliability and safety of hypersonic passenger flight
- Long life staged combustion cycle rocket engines
- Transpiration cooling to safely withstand a challenging aerothermal environment
- Fast turn-around times currently unknown in the launcher business

Some of these challenges characteristic for any high-energy transportation are addressed in the FAST20XX project. The work package 3 of FAST20XX looking at technologies for High-Energy Suborbital Transportation is organized in five different top-level lines, each one addressing a different technology to be developed and/or assessed:

- Mission Definition and System Analysis of the SpaceLiner (led by DLR SART as the creator of the concept)
- Heating, Flow and Flight Control (led by DLR's high-speed windtunnel division)
- Advanced Structures (led by Swedish research organization FOI)
- Low-Density Effects in Suborbital Flight (investigated by DLR and the Italian aeronautical research institution CIRA)
- Flight Dynamics and Safety (led by DEIMOS SPACE)

A more detailed list of the foreseen SpaceLiner technical investigation tasks in FAST20XX has been published in [7].

#### **4 TECHNICAL EVOLUTION OF THE SPACELINER CONCEPT**

Technical progress of the advanced SpaceLiner concept has been achieved in the frame of the EU funded FAST20XX study as well as also by internal funding of DLR. This section describing the latest evolution up to September 2010 is structured by the technical disciplines involved and not by their funding sources. Different configurations in terms of propellant combinations, staging, aerodynamic shapes, and structural architectures have been analyzed. A subsequent configuration numbering has been established for all those types investigated in sufficient level of detail. These investigations deliver important data for the next reference configuration SpaceLiner7 which is still in its definition process.

##### **4.1 Basic Requirements for a Rocket-Propelled Intercontinental Passenger Stage**

The very high-speed travel option of the SpaceLiner is most attractive on ultra-long haul distances between the main population and business centers of the world. A reduction in total travel time of up to 80 % seems to be achievable [5]. These centers can be identified at least in Australia, East Asia, Europe, and the Atlantic and Pacific coast of North America (compare ref. 5).

One of the most demanding missions in terms of  $\Delta-v$  is the west-bound flight from south-east Australia to a central European destination which is selected as the reference design case.

Different configurations and take-off modes have been analyzed. Horizontal take-off options, which are more conventional for passenger flight, have been dismissed because of unsolved problems related to cryogenic propellant sloshing and rocket engine feed. A parallel stage arrangement is preferred over a tandem configuration mostly due to the latter's expected outsize length of more than 100 m. The large wings of the two reusable stages in tandem arrangement would generate high bending loads on the structure.

The most important requirement for the overall design of the 'SpaceLiner' concept is an acceptable safety record. The specific number of fatalities in its operation should not exceed those of early jet-airliner travel. It has to be realized that such a requirement is a notable technical challenge in itself, far beyond the capability of today's manned spaceflight. The rocket engine powered 'SpaceLiner' is based on an advanced but technically conservative approach which does not rely on any exotic technologies. Thus, a two stage, fully reusable vehicle is designed as an "exceedingly reliable" system to overcome the safety deficits of current state-of-the-art launchers.

The rocket engines are intentionally not designed to their technical limits to improve their reliability. Intensive testing and qualification of the propulsion system is further essential. Nevertheless, an engine-out capability during all acceleration flight phases is to be integrated. Despite all effort, tight margins are intrinsic of all launch systems and significantly reduce the achievable safety and reliability. Thus, a passenger rescue system will be indispensable. This could be envisioned as a cabin in the form of a large capsule to be separated from the orbiter in case of an emergency and then safely returning to Earth (see section 4.5).

Although the reusable upper stage with the passenger payload does not reach stable orbital velocity during nominal missions of the reference design, its conditions are so similar to those of an orbiter that the vehicle is also dubbed as 'orbiter' in the following paragraphs.

##### **4.2 SpaceLiner2 reference design**

The technical evolution of the SpaceLiner concept is based on the configuration 2 status of 2007 described for the first time in [8]. Major technical data are again summarized in this section.

Fuel rich staged combustion cycle engines with a moderate chamber pressure, approximately 1700 kN thrust in vacuum were selected for the propulsion system of the two stages already in the early designs [1]. These engine performance data are not overly ambitious and have already been exceeded by existing engines like SSME or RD-0120. However, the ambitious goal of a passenger rocket is to considerably enhance reliability and reusability of the engines beyond the current state of the art.

All engines should work from lift-off until MECO. A propellant crossfeed from the booster to the orbiter is foreseen up to separation to reduce the overall size of the orbiter stage. The expansion ratios of the booster and orbiter engines are adapted to their respective optimums, while mass flow, turbo-machinery, and combustion

chamber remain identical. These engine characteristics are listed in Table 1.

**Table 1: Engine data of SpaceLiner2**

	Booster	Orbiter
Number of engines	8	2
Mixture ratio	6:1	6:1
Chamber pressure [MPa]	16	16
Mass flow per engine [kg/s]	384.5	384.5
Expansion ratio [-]	33	59
Specific impulse in vacuum [s]	437.6	448
Specific impulse at sea level [s]	388.4	360.4
Thrust in vacuum per engine [kN]	1650.6	1689.8
Thrust at sea level per engine[kN]	1465.0	1359.4

The booster is a large unmanned tank structure providing thrust and propellant crossfeed to the orbiter up to staging. Its total propellant loading including residuals reaches 760 Mg, 105 % of the Space Shuttle External Tank. Compare Figure 3 for the resulting launch configuration and the characteristic SpaceLiner data in Table 2.

The orbiter, designed to transport 50 passengers with their luggage, accommodates no more than 155 Mg propellant in the aft section which is designed as an aeroshell-like concept. Aerodynamic considerations and severe thermal conditions in the atmospheric skipping phase (see [2, 8] and section 4.7 below) exclude any integral tank structure. The orbiter's structural index is at 60 %, relatively conservative for a large cryogenic RLV. However, it must be considered that the vehicle has to include a passenger cabin and safety features.

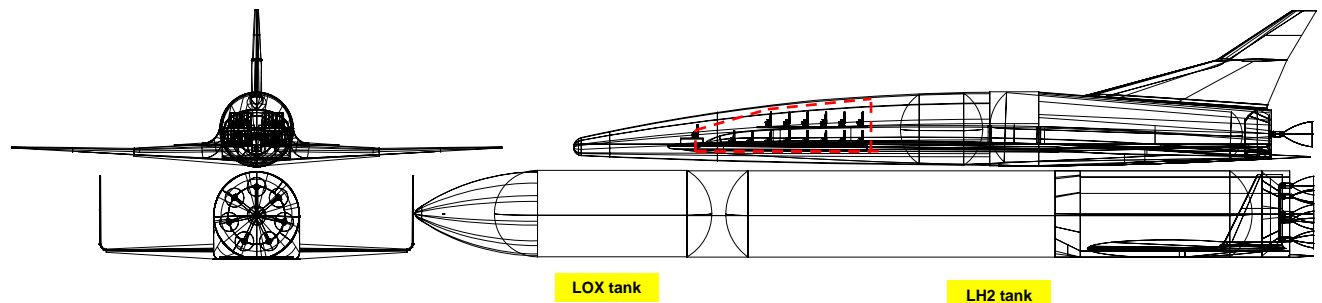

**Figure 3: Generic rocket-powered intercontinental passenger spaceplane SpaceLiner2 (top) with reusable booster (bottom) in CAD wireframe drawing showing internal arrangement, red line is highlighting capsule section**

**Table 2: SpaceLiner2 characteristic vehicle data (reference mission)**

	GLOW Mass [kg]	Mass at burnout [kg]	Nominal Ascent Propellant mass [kg]	Total length [m]	Max. fuselage diameter [m]	Wing span [m]	Projected wing surface area [m <sup>2</sup> ]
Orbiter	275200	120200	155000	60.4	6	40	955
Booster	870960	116960	754000	73.4	7	25.5	325

Different SpaceLiner trajectories with intercontinental destinations have been analyzed. One of the most demanding practical missions is the west-bound flight from south-east Australia to a central European destination which has been selected early as the reference design case [1].

After performing a vertical take-off, the combined launcher accelerates for 215 s up to 3.2 km/s (beyond Mach 11) when the booster separates. After its MECO the booster performs a ballistic reentry and will be transferred back to its launch site by the patented method dubbed 'in-air-capturing' which has been investigated by DLR in simulations and has proven its principle feasibility [9, 10]. A fairly similar method has been proposed and studied in Russia [11]. The massive advantage of this approach is the fact that a booster stage caught in the air does not need any fly-back propellant and turbo-engine propulsion system. The mass savings on the RLV stage by in-air-capturing allow for a significantly smaller vehicle or a payload increase [9]. The innovative capturing has been selected as the baseline technology for the booster retrieval,

enabling a total lift-off mass reduction of at least 150 Mg. Conventional turbojet fly-back or a downrange landing site, if available, are the backup options, if 'in-air-capturing' would be deemed as unfeasible or as too risky.

Following separation, the orbiter with the passengers inside accelerates for another 200 s to its MECO conditions close to 6.55 km/s at a relatively low apogee altitude of 85 km. Conditions are still clearly suborbital with a perigee of -3360 km.

Different flight options exist in principle after MECO. The atmospheric skipping looked most attractive considering achievable flight range, launch mass, and mechanical loads [1]. However, the stagnation point heat flux might exceed 4 MW/m<sup>2</sup> (2.1 MW/m<sup>2</sup> in nose region) for a short time [8]. New approaches for the structural materials and thermal protection including advanced active cooling have to be implemented. Some promising design options are outlined in [12] and briefly in section 4.7 below.

The highly challenging technical issue of the extremely high heat flux might be resolved if the SpaceLiner were to achieve a higher MECO velocity. This would effectively stretch the range of a single ballistic arc to a point where the following atmospheric entry could be kept within mechanical and thermal loads of existing orbiter vehicles like Space Shuttle or Buran. The SpaceLiner would thus not use a skipping trajectory anymore, but instead a single ballistic arc followed by conventional re-entry. On the downside this solution would require almost 1000 m/s additional  $\Delta-v$  resulting in a much heavier launcher and heavier and larger orbital stage. Therefore, the low orbital option is only a backup in case the reference skipping variant should turn out to be technically unfeasible or too risky.

After approximately 5400 s (1.5 hours) flying the reference mission along the orthodrome, the SpaceLiner should reach its final destination.

### 4.3 Passenger Load-Environment

The overall flight environment for SpaceLiner passengers inside the cabin with respect to acceleration loads is, as expected, very different to conventional subsonic airplanes. After a vertical take-off the axial load factor rises until the booster main engines are throttled or are subsequently cut-off when the axial acceleration reaches  $25 \text{ m/s}^2$  (2.6 g). During that period the nominal normal load factor remains considerably below 1 g. (Figure 4, top) After about 120 s of almost 0 g weightlessness following orbiter MECO, the skipping trajectory starts. The periodic drag deceleration  $n_x$  never exceeds -0.2 g. The normal load factor  $n_z$  is controlled at a nominal design maximum of +1.5 g and a minimum of +0.026 g in the ballistic arc succeeding the first skip. (Figure 4, bottom) Afterwards both extremes are closing in on the normal flight condition of 1 g.

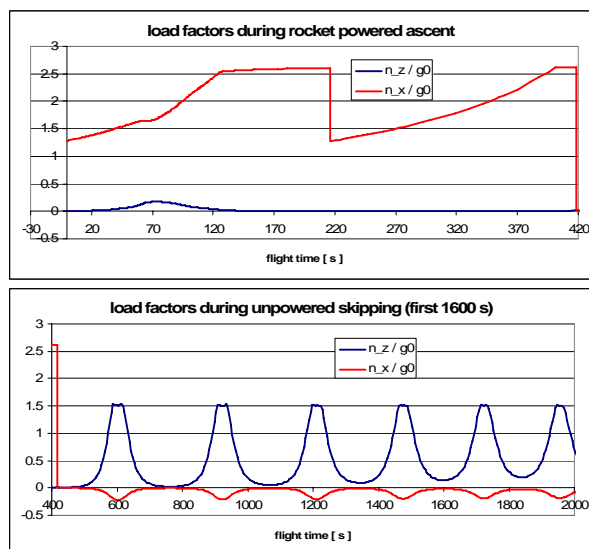

Figure 4: Load factors  $n_x$  and  $n_z$  of SpaceLiner2 along reference trajectory

According to FAA/EASA standards, the airframe and the passengers aboard all civil airliners are required to withstand maximum off-nominal  $n_z$  loads up to 2.5 g. The SpaceLiner comfortably stays within these limits. However, the load frequency (starting with a period of approximately 320 s for the reference mission) is much

different to that in conventional passenger aircraft. Although, the environment could best be characterized by that experienced while sitting on a gently moving very long swing, the passenger medical conditions will be checked in FAST20XX for their acceptability [7].

### 4.4 Vehicle trade-off studies

Several configuration trade-offs have been performed in order to support the definition of the next reference configuration already dubbed "SpaceLiner7". The level of engineering detail of the traded configurations is not exactly the same as for the previous reference SpaceLiner2 type. E.g. full CAD models have not been generated. However, obtained data of the interim research configurations 3, 4, 5, and 6 are at sufficiently high quality because they have been iteratively sized with careful scaling of the reference mass break-down, preliminary aerodynamic sizing and always trajectory optimization. Some of these configurations are described in this paragraph. A full documentation of all trade-off results can be found in [14, 15].

For the interim configuration SpaceLiner3, the wing surface area had been slightly enlarged. Also the central fin on the orbiter has been removed and instead large winglets were introduced to produce lateral stability and control. Improved aerodynamic performance results in a reduced takeoff mass of almost 100 tons compared to the reference variant 2. However, the effectiveness of the winglets as a replacement of the horizontal stabilizer is questionable and thermal and mechanical loads on the relatively thin winglets are critical. Hence the investigation of this configuration is no longer continued.

The development of the SpaceLiner4 version was the first activity in the framework of FAST20XX. The difference with respect to the reference SpaceLiner2 is the fact that the trim drag of the elevator deflection has been taken into account more carefully than for the previous configurations. In order to minimize significant losses in hypersonics, the wing has been moved forward by 5.7 m.

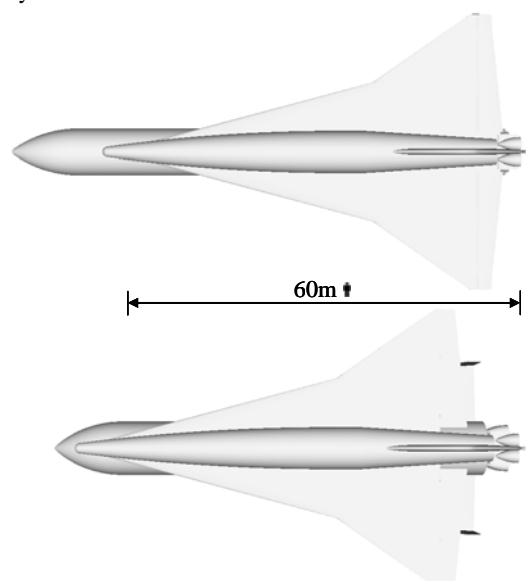

Figure 5: Generic rocket powered intercontinental passenger spaceplane SpaceLiner4 (bottom) compared with the SpaceLiner2 (top)

Nevertheless, the required  $\Delta-v$  obtained from an iterative sizing increased by 0.15 km/s. This in turn results in an increased propellant mass of 77 tons and hence an additional engine on the booster stage and a larger booster structure. GLOW increases by almost 88 tons. To be able to fit this extra engine on the booster, the booster diameter has been increased by 1 m, resulting in a shorter booster than used for the SpaceLiner2 (see Figure 5). Data on the masses and dimensions of the SpaceLiner4 are listed in Table 3. The new aerodynamic data sets including trim drag are documented in [14, 15].

From an operational point of view, a single stage configuration would be preferable eliminating the need for the booster's return to a launch site and subsequently the mating of both stages. Further, such a vehicle would be less risky because of avoiding the inherent danger related to the staging maneuver. However, the minimum  $\Delta-v$ -requirement of more than 6500 m/s without losses for the reference mission will require SSTO technology, nevertheless resulting in a very large and outside stage. Although these considerations were already well known in the early SpaceLiner designs driving the two-stage approach, the FAST20XX study allowed again the systematic assessment of a single stage vehicle on shorter distances than the reference mission.

It is interesting to see how big the passenger stage should be to fly a meaningful mission on its own. The flight from Western Europe to the East Coast of the USA, carrying 50 passengers is the chosen mission for this analysis. For flying this distance in a single stage configuration, the orbiter must be about 85 m long and requires 452 tons of LOX/LH2 propellant, resulting in a total mass of 610 tons. Six engines of the type for the orbiter defined in Table 1 are needed. The flight time for crossing the Atlantic would be about 55 minutes while the velocity at burnout would reach about 4.5 km/s at an altitude of approximately 50 km. A significant throttling requirement (typical for all single stage vehicles) up to 60% is needed not to exceed 2.5 g. This goal is achievable by cutting-off three engines.

Table 5 summarizes the masses and dimensions. Figure 6 shows a picture of the single stage SpaceLiner6.

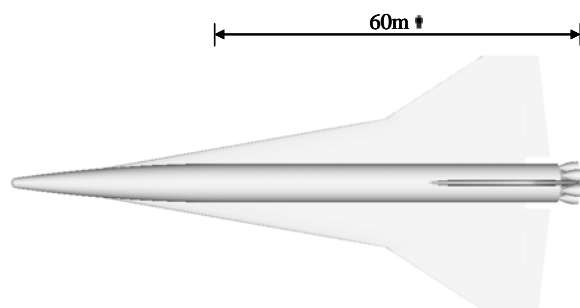

**Figure 6: Generic single stage rocket powered intercontinental passenger spaceplane SpaceLiner6 sized for transatlantic mission**

The analyses clearly demonstrate the challenges of single stage concepts even on shorter distances for which the flight time reduction advantages of the SpaceLiner concept are diminishing. The optimum choice of the propellant combination is not obvious without detailed analyses. In combination

with LOX as the oxidizer, the fuels RP (kerosene) and LH2 are of interest. Kerosene might be especially advantageous for the booster stage to limit its large size and stay more compact.

The SpaceLiner5 version is another two stage configuration designed for the reference mission using the same orbiter as the SpaceLiner4 version. The only changes are made to the booster, where the propellants are now LOX and RP1. The much higher density of kerosene compared to hydrogen could result in a smaller booster, but on the other hand it must be taken into account that the specific impulse of LOX/RP1 is considerably lower. In consequence the total system mass at lift-off will probably get heavier. As the orbiter remains unchanged and propellant crossfeed is still foreseen until separation, the booster is also equipped with an LH2 tank to feed the orbiter engines. The booster therefore actually contains three tanks; a LOX tank used by both the orbiter and the booster engines, an RP1 tank for the booster engines and an LH2 tank for the orbiter engines during the early part of the ascent when the orbiter is still attached to the booster.

The kerosene engines for the booster stage are based on the advanced, but already existing since two decades RD-180 and RD-171 engines from Energomash, which achieve very high performance for RP-propellant; e.g. a specific impulse of almost 338 s in vacuum [16]. To gain sufficient thrust at take-off, two RD-171s and a single RD-180 are needed for the booster.

Table 4 shows the SpaceLiner5 dimensions and masses. The booster is 8.6 m shorter and its diameter is 1 m smaller compared to the fully cryogenic SpaceLiner4. A graphical representation can be found in Figure 7. The total propellant mass stored in the booster has increased by 262 tons. Nevertheless, the booster empty weight is reduced by 9.4 tons. Overall the size difference is relatively small, but additional system complexity is added due to the different engine and propellant types on booster and orbiter. Moreover, the SpaceLiner with these two fuel types would lose some of its environmental friendliness because the LOX-RP-booster engines are producing not only water but also a significant amount of CO and CO<sub>2</sub>.

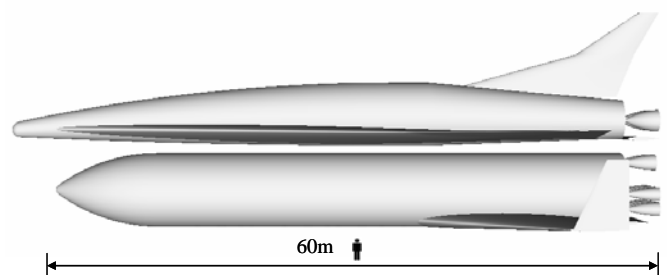

**Figure 7: Generic rocket powered intercontinental passenger spaceplane SpaceLiner5 with RP1 used for the booster engines**

The Australia – Europe mission is one of the most technically challenging distances with significant passenger volume. However, several northern hemisphere flights like trans-Pacific or trans-Atlantic are less challenging but offer a larger market potential. Thus, the flight from Europe to the west coast of North America, with a minimum orthodrome distance around



9000 km, has been investigated for its suitability with the SpaceLiner2 configuration. An elongated orbiter derivative could transport 100 passengers on this mission in one hour with the same booster stage [8]. Reference 15 presents some trajectory simulation results of other flight connections like East Asia to Europe or to North America. The challenge to be addressed in the next steps of the design process will be how to service all SpaceLiner missions with a minimum number of different stages optimally adapted to the passenger volume. Similar problems exist in the airliner business but the high performance requirement of the SpaceLiner reduces the margins for technical compromises.

In FAST20XX additional trajectory optimizations are performed in preparation of the flight dynamic assessment. Figure 8 shows two different ground tracks of the reference mission obtained from ASTOS optimizations. The red line close to the orthodrome is similar to the baseline assumption. The black line on a more northward track achieves the same range at about the same flight time with considerably reduced fuel consumption of the booster. The optimization of the launch azimuth with 3-dimensional control of the

vehicle is obviously an important task to be performed in the next steps of the SpaceLiner design process.

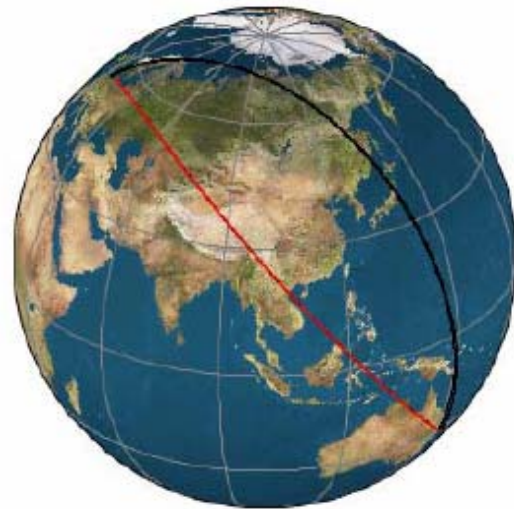

**Figure 8: Different ground tracks from simulations of reference mission Australia – Europe depending on launch azimuth**

**Table 3: SpaceLiner4 characteristic vehicle data (reference mission)**

	GLOW Mass [kg]	Mass at burnout [kg]	Nominal Ascent Propellant mass [kg]	Total length [m]	Max. fuselage diameter [m]	Wing span [m]	Projected wing surface area [m <sup>2</sup> ]
Orbiter	275200	120200	155000	57	6	40	955
Booster	958542	127542	831000	64.3	8	25.5	325
Total	1233742	247742	986000	-	-	-	-

**Table 4: SpaceLiner5 characteristic vehicle data (reference mission)**

	GLOW Mass [kg]	Mass at burnout [kg]	Nominal Ascent Propellant mass [kg]	Total length [m]	Max. fuselage diameter [m]	Wing span [m]	Projected wing surface area [m <sup>2</sup> ]
Orbiter	275200	120200	155000	57	6	40	955
Booster	1210705	118105	1092600	55.7	7	25.5	325
Total	1485905	238305	1247600	-	-	-	-

**Table 5: Single stage SpaceLiner6 characteristic vehicle data (transatlantic mission)**

	GLOW Mass [kg]	Mass at burnout [kg]	Nominal Ascent Propellant mass [kg]	Total length [m]	Max. fuselage diameter [m]	Wing span [m]	Projected wing surface area [m <sup>2</sup> ]
Orbiter	610340	158340	452000	85.2	6	40	1298

#### 4.5 Pre-development of a passenger rescue capsule

The tight margins intrinsic of all launch systems make a dedicated passenger rescue system indispensable for viable SpaceLiner operation. A straight forward and least exotic form is a cabin designed in the form of a large capsule to be separated from the orbiter in case of an emergency and then safely returning to Earth.

A preliminary design of a passenger rescue capsule has been recently performed in a multi-disciplinary, iterative approach [17], taking into account NASA manned system requirements [18], considering:

- Defining the capsule geometry

- Approximation of its aerodynamic characteristics
- Calculation of aerothermodynamic heating and choosing its heat shield
- Trajectory analysis demonstrating the vehicle dynamics and loads in off-nominal flight
- Dimensioning of the separation motors and defining other subsystems and hence creating a reliable first mass model of the passenger rescue system.

A fundamental requirement for the design of the rescue capsule is its integration in the front section of the passenger stage. The capsule should be separated as easily and quickly as possible. Therefore, it is not an integral part of the fuselage structure. The dashed red line in Figure 3 shows the approximate position of the

capsule and that its upper aft section is conformal with the SpaceLiner's fuselage while the lower side is fully protected by the fuselage bottom structure. The cabin might be attached late in the launch preparation process when the tanks are already filled.

The flight of the SpaceLiner has been divided in three phases for the pre-design of the rescue capsule and its subsystems. Different actions have to be performed to guarantee a safe separation, distancing and afterwards a safe landing of the rescue capsule.

During the early **ground** operation and early **lift-off** phase it is important in an emergency to rapidly gain distance but also to gain altitude. Otherwise the capsule would crash on the ground after separation without time to deploy the parachutes. Separation boosters behind the passengers pointing upwards lift the capsule. Separation pitch engines change the direction of the capsule to an angle of 48°. The capsule would have to roll around its x-axis because of the vertical position at the launch pad. Thus, additional control engines are required. It is assumed that an explosion on the launch pad is the worst-case scenario since the tanks are full and with increased altitude the shock wave loses its power. Though it is very unlikely that the whole propellant explodes at the same time, this event is assumed as the rescue system design case. The liquid-propellant is described as the equivalent quantity of TNT and the explosive characteristics are derived from diagrams. As the passengers are in the rescue capsule the limit of the overpressure is depending on the pressure limit of the capsule which is set to 60 kPa. The overpressure falls below this value at sea level at a distance of approximately 250 m reaching this point in 380 ms [17].

If a severe malfunction is noticed during the **ascent**, it is crucial for the capsule to leave the SpaceLiner flight path to avoid being hit by the remains of the SpaceLiner. The capsule has to be rotated around the x-axis to make the deployment of parachutes possible and orient the main TPS towards maximum heat loads. With the gaining of altitude, the atmospheric pressure and therefore the impact of an explosion is reduced. At about 33 km altitude the overpressure falls below 60 kPa already at a distance of 25 m from the explosion. The velocity of the shockwave also decreases, impacting the necessary prediction time for an automatic separation system to approximately 0.65 s [17].

After passing the highest point the unpowered **descent** phase begins. The propellant tanks are empty and do not pose a risk anymore. The SpaceLiner orbiter is gliding after MECO in a horizontal position with small flight path angles hence it is not required to rotate the capsule around the x-axis. Three different hypersonic trajectory points of interest are chosen:

- The lowest point of the first skip with very high velocity in a relatively dense atmosphere results in a high heat flux and dynamic pressure.
- The fastest point during the whole SpaceLiner flight. Accompanied by a high heat load and dynamic pressure.
- The highest point of the trajectory. Shortly after the MECO it exposes the passengers to very high g-forces and dynamic pressure.

A detailed analysis of the Separation Propulsion System and the Thermal Protection System is made as they are regarded to be the most critical components.

The cabin rescue system of the SpaceLiner concept requires powerful solid separation motors with a very short burn time to enable the capsule reaching a safe distance for passenger evacuation while not being destroyed by the overpressure of the blast wave [18]. Such boosters cannot be found as off-the-shelf products, thus dimensions have to be approximated. The separation system will be placed between the passengers and the tanks of the SpaceLiner. Thus, the motor's length, is limited. A propellant mixture of HTPB, AP and Al is used and burnt at 150 bar chamber pressure.

The reaction control system is divided into a front and aft section on the upper part of the capsule with orientation in the upward and sideward directions to enable rotation around its major axes. Each thruster is integrated as a pair to allow for redundancy (Figure 9).

The TPS of the capsule is subject to high heat flux and has no need for re-usability. Therefore, an ablative thermal protection is preferred with low system complexity, thus guaranteeing high safety. The insulation material on the upper side of the capsule could be similar to the SpaceLiner's fuselage upper side because in some regions it is the same surface. The relatively low heat loads allow for a thin multi-layer insulation as already used for the Space Shuttle orbiter or a metallic TPS (compare section 4.7).

The landing system of the capsule is a parachute-solid retro-booster combination, this choice being made because of a significant mass reduction. Energy absorbing seats with integrated small airbags might also reduce the loads on the passengers in case of an emergency landing. In case of a water landing the buoyancy of the rescue capsule has to be greater than the gravitational forces. The buoyancy is 9 times larger than the gravitational forces [17], thus fully compliant.

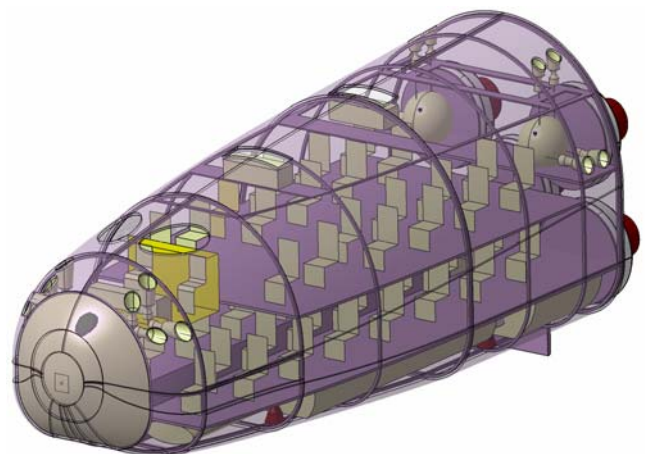

**Figure 9: CAD model of rescue capsule variant 2 in isometric view (from front) [17]**

A comparison of round and flat bottom geometry and different sizes and positions of the body flap have been investigated to find the optimum aerodynamic configuration with respect to trim and controllability requirements in hypersonics.



The total mass of the passenger rescue system additional to the cabin structure and internal passenger equipment is estimated at about 7.65 tons. The largest part of this mass of more than 3 tons applies to the separation motors. The overall mass penalty fits quite well with the early SpaceLiner2 assumption. The length of the capsule reaches almost 15 m and its maximum diameter is close to 5.7 m. The total mass of the fully equipped capsule, including the passengers and payload after burn-out of the separation motors, is estimated to be slightly above 29 tons. The overall size of the capsule is challengingly large with its landing mass about three times that of the largest capsules built to date. An interesting option in the design of SpaceLiner7 is splitting the passenger and crew cabin into two parts which might also improve the utilization of the long nose section. Several trade-offs are still necessary to find the optimum configuration.

#### 4.6 Aerodynamic shape refinement

A study performed in [15] shows a high sensitivity of the orbiter's hypersonic L/D on the achievable range. Dependence is almost linear with a 0.25 improvement in L/D allowing for 1000 km additional range. Since losses by trimming and flight control using flaps are unavoidable, the optimization of the aerodynamic shape is of paramount importance.

Safe controllability of the vehicle in all flight conditions has to be assured including during abort cases. The Mach number range stretches from the hypersonics through the transonic regime to the low speed subsonic landing approach. An extensive study on the different geometrical options for the optimization of the hypersonic aerodynamic and aerothermodynamic characteristics of the SpaceLiner has been recently concluded at DLR [19].

Using simplified shapes for the nose, fuselage, wing, and horizontal stabilizer, a numerical optimization of the hypersonic characteristics has been performed by CFD calculations with the fast modified Newtonian Method. Controllability issues were not addressed but the leading edge heat fluxes are considered. Figure 10 shows a few results of the optimizer for maximum L/D and parametric variation of acceptable leading edge temperature.

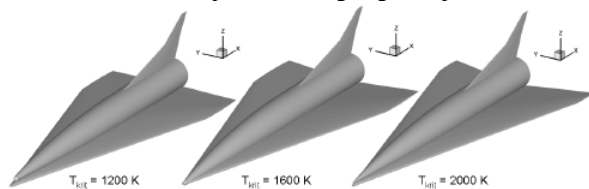

Figure 10: Promising numerically optimized geometry options of the SpaceLiner orbiter stage [19]

Single-Delta wing configurations as shown in Figure 10 offer some advantages for increased hypersonic L/D and reduced leading edge heat transfer compared to SpaceLiner2's double-Delta. The transonic and subsonic behavior of such wing shapes seems to be also acceptable according to preliminary analyses. The SpaceLiner2's NACA-66 airfoil remains the baseline because of good overall behavior found in the optimization process [19].

The SpaceLiner should have natural longitudinal stability in the hypersonic flight regime because the aerodynamic forces at some points of the trajectory might be too low for efficient generation of artificial stability. The trailing edge flaps have been preliminarily defined as elevons with two flaps on each wing for redundancy in case of blockage.

The final outer aerodynamic shape of the SpaceLiner7 is planned to be frozen in early 2011 taking into account the results presented in this paragraph, more detailed CFD of low-speed aerodynamics, as well as structural considerations and integration of a passive thermal protection (see subsequent paragraph 4.7).

#### 4.7 Preliminary structural and TPS concept of the passenger stage

For all previous SpaceLiner configurations only relatively sketchy structural concepts exist. This situation will change to a more detailed analysis in the definition of SpaceLiner7 with the FAST20XX support of FOI from Sweden and Orbspace from Austria. A few baseline choices have already been fixed.

An aeroshell-like structure for the passenger stage is most promising because of decoupling the maximum thermal gradients between cryogenic tanks and the outside surface. The internal protected structure could be metallic or CFRP. Materials with sufficient strength at elevated temperatures (e.g. 250°C, > 500 K) like Titanium or the polymer PEEK could be interesting for reducing the insulation thickness and hence the TPS mass. Design trade-offs are required to find an optimum technical solution.

A preliminary structural sizing of the wing is already running, taking into account the loads and dimensions of the main gear and flap actuator forces and moments. Figure 11 shows the von-Mises stress distribution in the wing for a hypersonic load case.

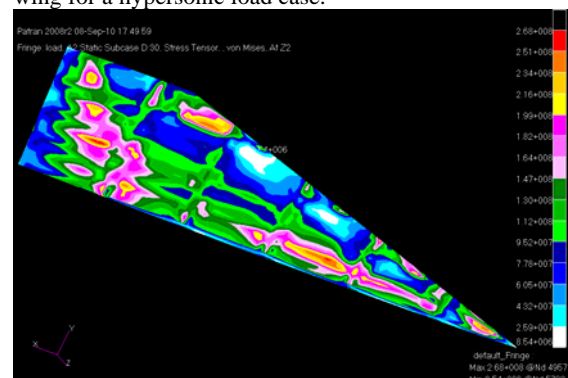

Figure 11: Von-Mises stress distribution in NASTRAN FE-model of wing

The most severe aerothermal conditions are found during the SpaceLiner's first skip. The maximum heat flux at the stagnation point is about 2 MW/m<sup>2</sup> but could reach 4 MW/m<sup>2</sup> on the leading edge. The outboard leading edge of the double-delta wing is found to be most critical and might be subject to additional shock-shock and shock-boundary layer interaction further raising the heat loads in this region. Although the heat peaks are relatively short transient phenomena of about 100 s, a first estimation reveals that actual wall

temperatures on the leading edges and nose reach about 3000 K and 2600 K, respectively [2, 8].

A peak temperature of 3000 K is well beyond the capabilities of any available material. Thus in a limited area of the vehicle, advanced active cooling processes must definitely be implemented should the SpaceLiner orbiter maintain its ambitious skipping flight. Fortunately, some promising ceramic materials exist which sustain very high temperatures and which are also capable of transpiration cooling due to their porosity. The principle of transpiration is a promising cooling approach making use of two phenomena: Firstly, the porous structure will be cooled by convection of the coolant flow. Secondly, a thermal blocking coolant layer is built on the outer, hot surface of the porous structure, which reduces heat transfer to the surface.

In order to make the cooling system as light as possible, a coolant with high cooling capacity per kg has to be used. For the SpaceLiner it is therefore proposed to use liquid water as a coolant, potentially much more effective than gas. The principal feasibility of this active cooling approach has already been experimentally demonstrated [12]. During FAST20XX a more extensive and systematic research, scanning different geometries and materials will be run at DLR's arc heated facility. These experiments are scheduled to start at the end of this year.

The maximum acceptable temperatures for the passive TPS should be limited to approximately 1850 K to be compliant with the reusability requirement. A concept of passive TPS with C/C-SiC external surface and fibre insulation is promising on the lower side of the vehicle. Zirkonium-fibers might be of interest due to their increased heat resistance. The vehicle's upper side could see a metallic thermal protection to avoid potential problems with the water resistance of ceramic TPS material.

## 5 CONCLUSION

A conceptual reusable winged rocket for very high-speed intercontinental passenger transport is proposed by DLR. Research on the vehicle is performed with support from the EU project FAST20XX. Assuming advanced but not exotic technologies, a vertically launched rocket powered two stage space vehicle is able to transport about 50 passengers over distances of up to 17000 km in about 1.5 hours.

Rocket engines are well known in their performance characteristics but are also notorious in their low reliability and life time. Significant improvements in the latter fields as well as additional vehicle safety measures are indispensable for passenger flights of such concepts. A passenger rescue capsule has been pre-defined which should allow for a safe landing of the people on board even in case of a launch site explosion of booster and orbiter stage.

An atmospheric skipping trajectory is found technically attractive for the rocket plane after its MECO. FAST20XX studies if the related alternating normal loads are acceptable for the passenger's health and comfort.

The next iteration step of the SpaceLiner concept will be version 7 which will be based on much more detailed design of different subsystems and vehicle structures. An integrated interdisciplinary design process of the passenger stage will be necessary based on the ongoing configuration trade-offs.

A single stage concept has again been looked at for missions with reduced flight range. However, even for a transatlantic trajectory the vehicle grows to considerable size and is subject to deep throttling requirements to stay within acceptable limits.

Replacing the low density liquid hydrogen by kerosene on the booster results in a somewhat smaller size but is counteracted by the much higher launch mass and additional system complexity. The use of kerosene as propellant is also not as environmentally friendly as hydrogen generated by solar electric power, which therefore remains the baseline fuel.

The aerodynamic shape of the SpaceLiner orbiter is now in an iteration process taking into account requirements of the hypersonic and subsonic flight regimes. Further, flight dynamics and controllability are considered. The structural concept of the passenger stage is defined as an aeroshell concept. Trade-offs are performed with different types of passive thermal protection and structural material always keeping good aerodynamic characteristics in mind. The temperatures at leading edge areas during the most severe skipping conditions may rise to 3000 K and therefore are to be actively cooled. Transpiration cooling could be an attractive countermeasure and in FAST20XX an experimental research campaign will be run in relevant conditions for the stagnation point and leading edges.

## 6 ACKNOWLEDGEMENTS

Part of this work was performed within the 'Future High-Altitude High-Speed Transport 20XX' project investigating high-speed transport. FAST20XX, coordinated by ESA-ESTEC, is supported by the EU within the 7th Framework Programme Theme7 Transport, Contract no.: ACP8-GA-2009-233816. Further information on FAST20XX can be found on <http://www.esa.int/fast20xx>.

The authors gratefully acknowledge the contributions of Mrs. Uta Atanassov, Mr. Josef Klevanski, Ms. Ingrid Dietlein, Ms. Carina Ludwig, Mr. Paul-Benjamin Eißmann, Mr. Paul Nizenkov, Mr. Francesco Cremaschi, Mr. Dominik Neeb, Mr. Tobias Schwanekamp, Mr. Alexander Kopp, Mr. Daniel Keller, and Ms. Olga Trivailo to the preliminary design of the SpaceLiner and the preparation of this paper.

## 7 REFERENCES

1. Sippel, M., Klevanski, J., Steelant, J.: Comparative Study on Options for High-Speed Intercontinental Passenger Transports: Air-Breathing- vs. Rocket-Propelled, IAC-05-D2.4.09, October 2005

2. Sippel, M., Klevanski, J., van Foreest, A., Gülhan, A., Esser, B., Kuhn, M.: The SpaceLiner Concept and its Aerothermodynamic Challenges, 1st ARA-Days, Arcachon July 2006
3. Sippel, M.: Introducing the SpaceLiner Vision, 7th International Symposium on Launcher Technologies, Barcelona, Spain, April 2-5, 2007
4. NN: Analysis of Space Concepts Enabled by New Transportation (ASCENT Study), Futron, January 2003
5. Sippel, M.: Promising roadmap alternatives for the SpaceLiner, Acta Astronautica, Vol. 66, Iss. 11-12, (2010)
6. NN: The Challenge Ahead for SpaceX, Editorial, Space News, June 14, 2010
7. Sippel, M.: SpaceLiner - a Visionary Concept of an Ultra Fast Passenger Transport under Investigation in FAST20XX, AIAA 2009-7439, 16th AIAA/DLR/DGLR International Space Planes and Hypersonic Systems and Technologies Conference, Bremen 2009
8. Sippel, M., van Foreest, A.: Latest Progress in Research on the SpaceLiner High-Speed Passenger Transportation Concept, IAC-07-D2.7.07, September 2007
9. Sippel, M., Klevanski, J.; Kauffmann, J.: Innovative Method for Return to the Launch Site of Reusable Winged Stages, IAF-01-V.3.08, Toulouse October 2001
10. Sippel, M., Klevanski, J.: Progresses in Simulating the Advanced In-Air-Capturing Method, 5th International Conference on Launcher Technology, Missions, Control and Avionics, S15.2, Madrid, November 2003
11. Antonenko, S.V.; Belavskiy, S.A.: The midair retrieval technology for returning of the reusable LV's boosters, 2<sup>ND</sup> EUROPEAN CONFERENCE FOR AEROSPACE SCIENCES (EUCASS) paper 1.3.08, Brussels July 2007
12. van Foreest, A., Sippel, M.; Gülhan, A.; Esser, B.; Ambrosius, B.A.C.; Sudmeijer, K.: Transpiration Cooling Using Liquid Water, Journal of Thermophysics and Heat Transfer, Vol. 23, No. 4, October–December 2009
13. NN: SEVENTH FRAMEWORK PROGRAMME, THEME 7 [Transport, Aeronautics], Grant agreement for: Collaborative Project, small or medium scale focused research project1, Annex I - "Description of Work", Project acronym: FAST20XX, Project full title: Future high-Altitude high-Speed Transport 20XX, Grant agreement no.: 233816, 06 January 2009
14. van Foreest, A., Sippel, M.: Report on mission definition and concept trade-off including preliminary aerodynamic database, FAST20XX report D3.1.1.1, SART-TN013/2010, 2010
15. Eißmann, P.-B.: Mission analyzes and Design optimization of the SpaceLiner, DLR internal report, SART-TN005/2010, 2010
16. N.N.: RD-180, Product Information Pratt&Whitney / NPO Energomash , UTC 1997
17. Nizenkov, P.: Preliminary Design Study of A Cabin Rescue System for the SpaceLiner, DLR internal report, SART-TN006/2010, 2010
18. N.N.: NASA-STD-3000 Man-Systems Integration Standards, Volume 1, NASA.1995
19. Schwanekamp, T.: Implementierung eines Kopp-lungstools zur Optimierung der Aerodynamik und Aerothermodynamik des SpaceLiner Konzeptes, DLR internal report, June 2010

*Further updated information concerning the SART space transportation concepts is available at:*  
<http://www.dlr.de/SART>