

## Development of the ExoMars Chassis and Locomotion Subsystem

S. Michaud<sup>(1)</sup>, A. Gibbesch<sup>(2)</sup>, T. Thueer<sup>(3)</sup>, A. Krebs<sup>(3)</sup>, C. Lee<sup>(4)</sup>, B. Despont<sup>(1)</sup>, B. Schäfer<sup>(2)</sup>, R. Slade<sup>(5)</sup>

<sup>(1)</sup>*Oerlikon Space AG*  
Schaffhauserstr. 580  
CH-8052 Zurich (Switzerland)  
[stephane.michaud@oerlikon.com](mailto:stephane.michaud@oerlikon.com)

<sup>(2)</sup>*DLR Institute of Robotics  
and Mechatronics*  
Oberpfaffenhofen  
D-82234 Wessling  
(Germany)

<sup>(3)</sup>*Autonomous Systems Lab,  
Swiss Federal Institute of  
Technologies, Zurich*  
CH-8052 Zurich  
(Switzerland)

<sup>(4)</sup>*von Hoerner & Sulger GmbH*  
Schlossplatz 8  
68723 Schwetzingen  
(Germany)

<sup>(5)</sup>*Astrium Limited*  
Gunnels Wood Road, COB 2,  
STEVENAGE, Herts, SG1 2AS  
(England)

### Abstract

*A mobile surface element is required in the frame of the ESA ExoMars mission for exploring Mars in order to investigate the environment and search for evidence of life. The mobility aspect is important in terms of range and duration but the rover and in particular the locomotion subsystem has also to fulfill other key mission constraints related to the Martian environment and the accommodation within the lander.*

*Taking into account all design drivers, a detailed investigation of suitable passive suspensions was performed in the frame of the ESA activity labeled "Exomars Phase B1 Rover Vehicle Chassis and Locomotion Subsystem Design". This task was achieved with the support of the Rover Chassis Evaluation Tool (RCET) presented in [2]. The trade-off and optimization phase cumulate in the selection of an optimal concept for the ExoMars mission.*

### 1. Introduction

In the framework of its Aurora Exploration Programme, which focuses on the development and implementation of technologies for missions to the moon and to Mars, ESA is currently developing the ExoMars Project, aiming at a launch in 2013 [1].

The ExoMars mission will search for traces of past and present life, characterize the Mars geochemistry and water distribution, improve the knowledge of the Mars environment and geophysics, and identify possible surface hazards to future human exploration missions.

In order to achieve this task, a Rover will carry a comprehensive suite of analytical instruments dedicated to exobiology and geological research: the Pasteur Payload. Over its planned 6-months lifetime, the Rover will ensure a regional mobility (several kilometres) searching for traces of past and present life. It will do this by collecting and analysing samples from within surface rocks, and from underground — down to a depth of 2 meters.

This paper focus on the development of this rover as far as the mobility aspect is concerned and in particular on the selection of an appropriate suspension system. The elements that enable the rover to traverse the surface of Mars that handle the traction, obstacle traverse and slope climbing are called the ExoMars Locomotion Subsystem or just locomotion S/S.

### 2. Main functions

The locomotion S/S is required for providing the motion on the Mars surface. This subsystem need to

include locomotion sensors in order to facilitate precise motion control and support the localization function. In general, the locomotion S/S has to perform the following primary functions:

- Accommodate within the lander (stow in a extremely limited space)
- Survive launch and transfer environment.
- Deployed itself and egress from the lander
- Achieved locomotion on Martian surface (e.g. slope gradeability, traverse obstacles)
- Achieved sufficient stability during the operational and the drilling phase

### 3. Suspension trade-off

The selection of the most appropriate locomotion concept needs to be based on defined criteria related to the main functions. Often, the trade-off of mobile device focuses exclusively on the locomotion performances. However, the ultimate objective for ExoMars is to design a locomotion subsystem that meets all of the mission requirements and in particular the main functions described in the previous section.

The challenge proposed by the ExoMars mission is to design a lightweight locomotion S/S that can be accommodated within the limited space available in the lander and deploy itself in order to safely egress from the SES before beginning the on-surface mission.

Therefore the highest ranked requirements indicate the fundamental importance of being able to reach the Martian surface and deployment itself into an operational configuration.

The second aspect is the ratio between the locomotion S/S mass compared to the payload mass. Because the mass that can be bring to the Martian surface is limited, reducing the mass of the locomotion S/S allow accommodating more scientific instruments.

The ExoMars rover depends exclusively on solar energy that is limited by the size of the solar panel. Therefore the displacement range per day can be limited by excessive power consumption.

Only after these design drivers comes the locomotion performance aspect. Reduced climbing ability will extend the travel distance in order to reach a site of scientific interest or even some site may be discarded. However, the mission can found place with reduced capability.

This is based on these assumptions that the ranking was established for the ExoMars Locomotion S/S trade-off.

### 3.1. Suspension Concepts

Choice of a 6x6 chassis configuration with passive wheel suspension such as represented by the three successful Mars rovers (SOJOURNER and the MER's) developed by the Jet Propulsion Laboratory (JPL) was driven by the typically bouldery terrains of the Martian surface as compared with that of the Moon which is essentially a smooth soil surface with shallow undulations. This key difference was learned from the first successful landings on Mars by VIKING 1 and 2 in 1976 and calls for mobile vehicles to have significant ground clearance and passive contour following capability for an adequate mean free path performance.

Wheeled chassis architectures are not only preferable for their simplicity and high reliability, but also because they can support superior obstacle performance of the vehicle by proper kinematic design while optimizing power consumption.

As was shown during the RCET activity [2] and by Bekker already, the optimum chassis layout for off-road vehicles in rough terrains is the six-wheeled train with multiple vehicle cab sections (Bekker, 1969). Such configurations allow to very well follow terrain contours and can cope with negotiation of isolated obstacles such as rocks, and make these vehicles particularly well-suited for operation on unprepared, rough surfaces such as can be found on Mars.

Thus, the trade-off is limited on a six motorized wheel concept connected to the rover body trough a passive suspension. The following concepts suitable for the ExoMars mission have been trade-offed:

- CRAB (4 different versions) [4]
- RCL-E including increase of the footprint for better stability [5]
- MER (2 versions) [6]
- V-Bogies (2 versions)
- 3 Bogies (3 versions)

The last two concepts are novel and to our knowledge were never presented in a paper. Therefore a brief description is given in the next section.

### 3.2. Simple bogies concepts

A suspension concept based on the previous RCL-E heritage was proposed by Astrium Uk. The so called "3

bogies” is based on three simple bogie located at each side of the rover and on the rear (i.e. longitudinal bogie). The three points attachment is a mathematically defined system that allow to passively keep all six wheel in contact with the ground, even in an uneven terrain.

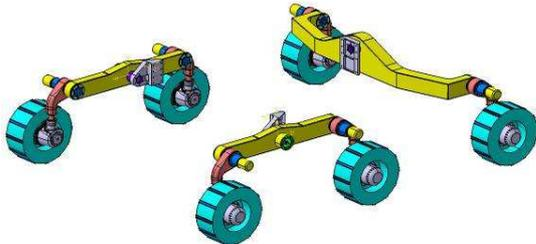

**Figure 1. 3 bogies conceptual design**

An option for modifying the motion of the wheels is to accommodate a v-shape bogie or a parallel bogie instead of the simple bogie in particular at the rear (i.e. longitudinal bogie).

### 3.3. Lander accommodation and egress

Depending on the suspension complexity, the stowing concept can have a significant impact on the deployed configuration and the overall mass. Therefore before evaluating the mobility aspect, the rover chassis key dimension needs to be defined based on detailed investigation of a suitable stowed configuration.

The ExoMars stowage volume allows deploying the wheels by rotating the legs around a deployment joint and locks it into place as represented in Fig.2.

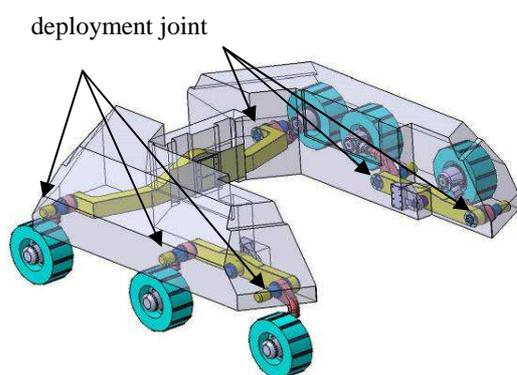

**Figure 2. Deployment concept**

This solution is suitable for all suspension concepts and lead of having the same footprint after deployment.

Because of its suspension complexity, the CRAB is the most penalized concept w.r.t. this criteria.

### 3.4. Locomotion S/S mass

A mass budget can only be established after a detailed design phase and is therefore not adapted to a trade-off exercise. Therefore comparison rules were established in order to trade the concept w.r.t. the mass criteria as follow:

- The weight of the suspension beam is estimated to be linear with the length. A mass / length ratio for the main and secondary beam as been established.
- The mass of each joint and other item like the differential drive mechanism (if any) is estimated
- The weight of the drive unit is established based on the required torque. This torque is an output of the quasi-static simulation tool [2].
- Due to similar deployment strategy, 6kg mass is added to all concepts.

**Table 1. Mass estimation**

	Mass [kg]	Torque [Nm]	Delta [kg]
CRAB	39.6	35.5	+4 kg
RCL-E	37.1	38.5	+1 kg
3 Bogies	32.3	35.5	-4 kg
V Bogies	35.2	TBD	-1 kg
MER	35.9	37.0	+0 kg

Even with the approximation used, the relative value gives an estimation of the mass difference between the concepts. Therefore, using MER as a benchmark, 4 kg can be won or loosed as a function of the selected concept. In general we can summarize the mass criteria as follow:

- The CRAB is penalized by its structural complexity even if the maximal required torque allows using a lightweight drive unit.
- The MER is penalized w.r.t the 3 bogies due to the differential drive mechanism and a slightly higher peak torque requirement. This torque requirement can be reduced by selecting other internal dimensions.

### 3.5. Power consumption

The power consumption per travel distance mainly depends on the efficiency of the components that are assumed to be the same for all concepts. The effective travel distance is a function of the mean free path (MFP). Therefore, the power consumption metric is included in the locomotion performance estimation.

### 3.6. Locomotion performances

#### 3.6.1. Stability

Because of the location of the rover body CoM, the stability in all direction on a 40° slope is an issue for the majority of the selected concepts. For having the possibility to check the five different concepts with different configuration (i.e. location of the CoM and internal geometry), a mathematical model and a quasi-static analytical tool are used.

The mathematical model solves the Newton-Euler equations on different slopes and for a rover orientations from 0° to 360° but consider the wheel as “blocked”. The 3 bogies result is presented in Fig 3.

The 2D simulator is presented in [2]. It solves the static equations for uphill and downhill orientation and features an algorithm that find the optimal set of torques that needs to be applied to the wheels.

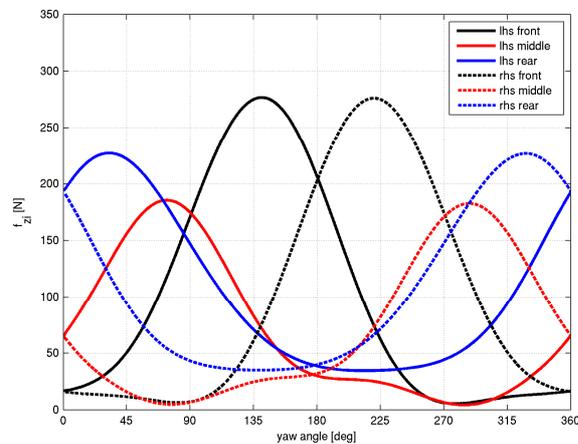

Figure 3. 3 bogies stability on a 40° slope

Based on the stability analysis presented on table 2, it appears that only the rocker-bogie (MER) and the 3 bogies are compliant with the stability requirement of 40°. For other concepts like the CRAB or the RCL-E alternative solutions needs to be implemented that required extra mass or the rover have an unequal wheel

load repartition on a leveled surface. The second option penalized the locomotion performances.

Table 2. Stability estimation

	Uphill	Downhill	Lateral
CRAB (mod 3)	+33°	-33°	>40°
RCL-E (mod 4)	+49°	-32°	>40°
3 Bogies (mod 1)	+41°	-44°	>40°
V Bogies	+40°	-36°	>40°
MER (mod 1)	+43°	-42°	>40°

Once the main dimensions are established and a CAD, model set-up, the 3D simulation tools presented in [2] was used to confirm the preliminary stability analysis. In particular this tool based on Simpack takes into account the reduction of the stability due to the deflexion of the wheels (particularly important when flexible wheel technology is used as explain in section 4.3).

#### 3.6.2 Motion in uneven terrain

Motion analysis on hard surface in particular over rectangular and hemi-spherical obstacles was performed. Because detailed design was not available at this stage, the criteria is the required friction coefficient in order to traverse the obstacle. The step shape obstacle is the most difficult to be overcome. It required a friction coefficient of 0.6 to 0.65 for all concepts except the RCL-E that require a coefficient over 1. Even 0.6 is a challenge for metallic wheels and special attention should be paid on the grouser design. Currently it is considered that only the RCL-E concept cannot traverse a 25cm step shape obstacle.

On lose soil (e.g. Martian sand) the slope gradeability depends mainly on the wheel design and the wheel load. The first parameter is independent from the suspension concept and therefore is not considered for the trade-off. What influence the slope gradeability but also the required drive torque and the power consumption is when the load repartition between the wheels.

Whichever concept is selected the internal dimension should be selected such as the wheel pressure at least on a levelled surface is equilibrated. This is the reason why only such version (“mod” in table 2) is considered in the stability analysis.

### 3.4. Trade-off summary

The accommodation within the Lander, the locomotion S/S mass estimation and the stability are clearly in favor of the 3 bogies and the MER.

Based on the simulations performed until now, we can conclude that the locomotion performances of the 3 bogies concepts are equivalent to a rocker bogie structure (type MER). In particular as far as 2D is concern (i.e. similar terrain on the left and right side of the rover). This is confirmed by the mathematical model that is identical for both concepts in such situation because the MER differential drive as well as the rear bogie are not acting in this situation.

The accommodation of a differential drive within the rover body is identified to be a main disadvantage compared to a rear bogie in terms of volume and mass. The 3 bogies concept presented in section 3.2 is also more adapted to the ExoMars stowage volume and is therefore the preferred concept.

## 4. Selected concept

As it was identified in [2] and during the locomotion performance analysis, the behavior in uneven terrain strongly depends on the appropriate selection of the geometry. In particular the location of the pivot points, the wheel design and the motion control should be selected appropriately. This is why an optimization phase was undertaken with also a focus to the deployment aspect.

### 4.1. Deployment

Once the Descent module has landed and it is deployed, the rover is ready to start the deployment. The main function of the deployment is to unfold the rover's legs from the stowed configuration.

The design team study different deployment options and had determined that the consequence of lifting the overall rover without an external mechanism will be to over design the actuators. A rover based lift system would have results on unnecessary mass to be carried out by the rover during the overall operational phase.

Another key feature of the suspension that has not been emphasized in previous flight application is the possibility to activate the deployment joints during the mission for modifying the footprint or for activating a so called wheel-walking mode. Therefore a possible

combination of deployment and wheel-walking actuator is proposed.

### 4.2. Wheel-walking option

The wheel-walking is described in [5] for the RCL-E and was adapted to the current selected concept. Adding 6 motors penalized the simplicity of the current passive suspension concept therefore wheel-walking mode is only considered to be a viable solution when combined with the deployment concept as proposed on Fig. 4.

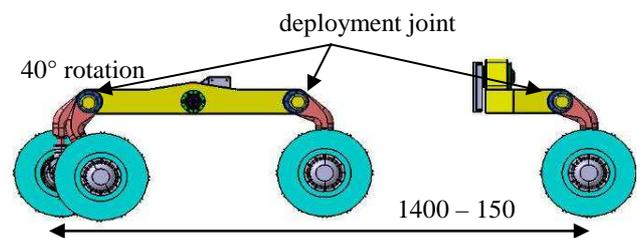

Figure 4. Wheel-walking mode

Due to the available space, the accommodation of actuators able to provide a sufficient torque for wheel walking (estimated in the 20 to 30Nm range) is a challenge. The utilization of an external lift system for the deployment would reduce the required torque at the joint to 6Nm.

Therefore a direct combination of the deployment and wheel-walking function could not be achieved. It has now to be decided if the increased of the actuator mass, volume and the overall complexity is balanced by the extended performances. This needs to be supported with a test in order to demonstrate the gain in terms of slope gradeability when using this motion mode.

### 4.3. Wheel design

The stowage volume limits the dimension of the wheel to approximately  $\varnothing 250 \times 100$ mm. This is similar to the NASA MER wheel with a reduced width. It should be noted that the gradeability required of the ExoMars rover on two soil types exceeds the demonstrated soil slope gradeability of the MER rovers which is  $\sim 20^\circ$  [7] and as such is a challenging requirement in particular with such wheels.

This means that alternative solution needs to be investigated. The first one is the wheel-walking mode presented in section 4.1. A second option could be the utilization of a deformable wheel structure that increases the effective wheel contact surface with the

ground. Based on the extensive utilization of a tractive prediction module (TPM) presented in [3], optimal flexible wheel parameters were defined that are compliant with the ExoMars mission slope gradeability requirements.

The ExoMars rover as the MER rover has the challenge of egressing from a lander poised on airbags and surface features, a maneuver that could require the vehicle to drop from a significant height (i.e. 25cm) above the surface. As presented in [6], the ability to absorb significant driving loads is a key aspect were the utilization of a flexible wheel is also advantageous.

The disadvantage is the space required by the flexible elements inside the wheel that limit the remaining available volume for accommodating the steering and drive unit.

A final consideration at this stage concerns the possible incorporation of protective, deformable mesh screens on the lateral faces of the wheel to prevent accumulation of fines and larger particles in the wheel interior as well as to provide shielding of the (hub-internal) drive mechanism from wind-blown dust on the Martian surface. Whether this is judged necessary and what a corresponding design could look like can only be decided once the shape of the wheel (in the transverse direction) has been clarified.

#### 4.4. Motion control optimization

For wheeled rough terrain rovers, the motion optimization is somewhat related to minimizing slip. Minimizing wheel slip not only limits odometric error but also increases the robot's climbing performance. In order to fulfil this goal, several methods have been developed.

One type of method uses the information of wheel slip to correct individual wheel speed, and thus allows limiting slip. An implementation of this type was done at JPL on the FIDO rover and is described in [8]. It is based on a velocity synchronization algorithm which minimizes the effect of the wheels "fighting" one another. Such methods account neither for the kinematic nor for the physical model of the rover.

The method presented in [9] includes a kinematic model to estimate the optimal velocity of each wheel depending on its trajectory plane. Since the kinematic state of an articulated rover moving in rough terrain changes continuously the wheels need different velocity inputs to avoid slip. This method takes into account the state of the rover and the topology of the

terrain, and tries to minimize slip by setting the input velocity to each wheel separately.

Torque control, however, needs the information about the state of the rover, the wheel ground contact angles, as well as the physical properties of the rover as inputs to the control algorithm. Since the load is shifted between wheels while the rover is moving on uneven terrain it makes sense to set the wheel torques accordingly in order to increase traction and minimize slip.

The foreseen locomotion S/S controller should incorporate a static model of the rover that allows calculating the optimal wheel torque depending on the rover's state. [10] provides a nice overview of torque control for a rough terrain robot and shows its superiority to velocity control.

A static model computed the optimal torques based on the state of the rover. These torques are only big enough for the rover to maintain its actual static state. In order to move forward the rover has to overcome motion resistance. Therefore, the torque optimization is integrated into the locomotion S/S control architecture depicted in Fig. 5.

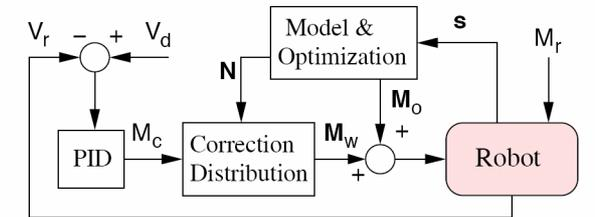

$V_d$	desired rover velocity	$M_o$	vector of optimal torques
$V_r$	measured rover velocity	$N$	vector of normal forces
$M_r$	rolling resistance torque	$s$	rover state vector
$M_c$	correction torque	$M_w$	wheel corr. torques

**Figure 5. Optimal motion control system architecture.**

The kernel of the control loop is a PID controller. It provides the additional torque to apply to the wheels in order to reach the desired velocity  $V_d$ .  $M_c$  is actually an estimate of the global rolling resistance torque  $M_r$ , which is considered as a perturbation by the PID controller. The rejection of the perturbation is guaranteed by the integral term of the PID. Because the rolling resistance is proportional to the normal force, the individual corrections for the wheels are distributed using

$$M_{wi} = \frac{N_i}{N_m} M_c$$

where  $N_i$  is the normal force on wheel  $i$  and  $N_m$  the average of all the normal forces. The derivative term of the PID allows to account for non modeled dynamic effects and helps to stabilize the system. The parameters estimation for the controller is not critical because we are more interested in minimizing slip than in reaching the desired velocity in an optimal way. For locomotion in rough terrain, a residual error on the velocity can be accepted as long as slip is minimized. Furthermore, the system offers an intrinsic stability because the ratio between inertia and motor torques is large.

Simulation and testing with a scaled breadboard demonstrate that on uneven terrain, locally wheel slip can be bigger with torque control but the total slip remains always smaller than speed control. Therefore the approach seems very promising to increase locomotion performance.

The effort to set up a model for the controller and to integrate the needed sensors in the locomotion S/S is rewarded by a significant reduction of slip. However, this comes at the price of increased system complexity, mainly in terms of additional sensors.

The main issue with torque control is the sensing of the wheel ground contact point. The test with the ExoMars breadboard will show if the information can also be obtained by use of simple force sensors at the drive shaft of the wheel which would simplify the future flight hardware development significantly

## 5. Flight model performances prediction

After the modification of the internal geometry mainly focus on the deployment and stability requirements the locomotion performances must be asses again. The simulation results are also more accurate than during the trade-off by using the preliminary flight design.

### 5.1. Obstacles

The results for maximum friction requirements on a step obstacle ( $h=0.25$  m) is confirmed to be between 0.60 and 0.65 for the forward direction but is 0.8 for the reverse direction. The results for the semi circle obstacle ( $h=0.25$  m) is between 0.4 in forward and 0.5 to 0.6 in reverse direction as a function of the final location of the CoM.

On a  $18^\circ$  slope, the required friction coefficient raise up to 1.0 value that is significantly over the current estimated value for the ExoMars wheel on a stone (i.e.  $\mu < 0.5$ ). It has to be noticed that the

simulation does not take into account the effect of the grousers that should help overcoming the obstacle. Testing will confirm the climbing ability of the locomotion S/S.

The required peek torque to overcome the gravitational resistance is 15.8 Nm for the step shape obstacle and below 12Nm for the hemi-spherical one on a leveled surface. On a  $18^\circ$  slope, the peek toque is between 24 and 29Nm. To this value the motion resistance as a function of the soil should be added and is considered to remain below 15Nm. Therefore, including some margin, a maximal peek torque requirement of 50Nm is proposed.

### 5.2. Simulation on uneven terrain

The simulation in 3D are all performed with the MBS tool based on Simpack. The main modification concerned the contact modeling and the wheel-soil interaction model.

The Polygonal Contact Model (PCM) developed within the scope of a thesis at DLR Oberpfaffenhofen is based on the polygonal representation of body surfaces. Therefore the comprehensively explained methods and algorithms for collision detection and contact patch approximation and discretization are closely related to computer graphics. For determining the contact stresses, the elastic foundation model is utilized extended by viscous damping and a regularized version of Coulomb's friction law.

When calculating the contact forces with the contact pair of wheel and surface area the latter is assumed as stiff contact surface and the wheel is defined with an area-related stiffness and damping coefficient.

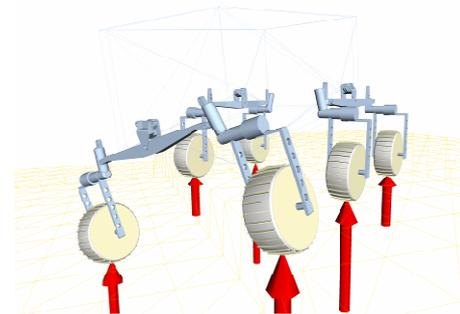

**Figure 6. 3 bogies simulation 25cm step down manoeuvre**

The specific wheel-soil interaction will be handled by an updated version of the TPM presented in [3].

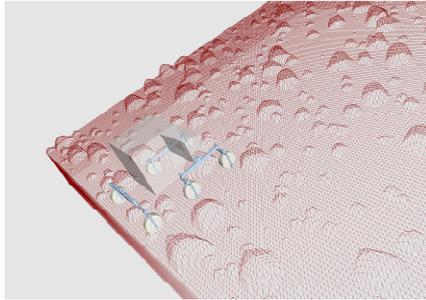

**Figure 7. 3D view of rover on terrain tilted 18°**

If the mean free path on the representative terrain is quite important, simulation results for the same terrain with 18° tilt and basic speed control show that the rover cannot cope with the obstacles and gets stuck after quite a short distance. This calls for a detailed performance analysis with a combination of both obstacles and slopes.

## 5. Testing

The manufacturing of a representative breadboard is on-going and will be tested with the test facility presented in [2] upgraded for this purpose. The breadboard features 2 axis force sensor and a torque sensor on each wheel in order to allow comparing simulation data with the measurement. Motion on Martian soil simulant will be conducted in the system level testbed facility located at OSZ in order to validate the prediction.

## 6. Conclusion

An extensive trade-off taking into account the specificity of the ExoMars mission was conducted that demonstrate the advantage of using a suspension concept based on simple bogies. The main criteria are the challenging limited space available to stow the locomotion S/S, the mass and the stability in all direction once deployed.

The locomotion performance are estimated to be similar to the NASA MER but alternative solution were identified to improve the motion or at east reduce the effect of using wheel with a smaller width.

Correct localization and good locomotion performance are crucial for an exploration mission where the rover operates autonomously over extended periods. Additional costs and efforts are therefore justified if the gain in performance is sufficiently high. Solution like wheel-walking mode, flexible wheel technology and optimal motion control were therefore

investigated and presented in this paper. Testing with a representative breadboard will support the final selection of which of these novel technologies should be implemented into the future flight model in order to have an optimal rover for exploring Mars.

## 6. References

- [1] P. Baglioni, R. Fisackerly et al., "The Mars Exploration Plans of ESA", IEEE Robotics & Automation Magazine, p 83-89, June 2006.
- [2] S. Michaud, L. Richter and al., *Rover Chassis Evaluation and Design Optimisation using the RCET*, Proceeding of the ASTRA 2006, ESTEC, the Netherlands, 2006.
- [3] L. Richter, A. Ellery, Y. Gao, S. Michaud, N. Schmitz, S. Weiß, *A Predictive Wheel-Soil Interaction Model for Planetary Rovers Validated in Testbeds and Against MER Mars Rover Performance Data*, proceeding of the 10<sup>th</sup> European Conference of the International Society for Terrain-Vehicle Systems (ISTVS), October 2006.
- [4] T. Thueer, P. Lamon, A. Krebs, R. Siegwart, *CRAB – Exploration rover with advanced obstacle negotiation capabilities*, Proceeding of the ASTRA 2006, ESTEC, the Netherlands, 2006.
- [5] V. Kucherenko, V. Gromov, I. Kazhukalo, A. Bogatchev, S. Vladykin, and A. Manykjan, "Engineering Support on Rover Locomotion for ExoMars Rover Phase A - "ESROL-A", Report for the European Space Agency (ESA) by Science & Technology Rover Company Ltd (RCL) 2004.
- [6] B.D. Harrington and C. Voorhees, *The Challenges of Designing the Rocker-Bogie Suspension for the Mars Exploration Rove*, Proceedings of the 37th Aerospace Mechanisms Symposium, Johnson Space Center, May 19-21, 2004.
- [7] L. Richter, M. Bernasconi, W. Buff, MIDD - Mobile Instrument Deployment Device. Final Report of the Study's Slice II. CCN 3 to ESTEC Contract No. 11230/94/NL/PP(SC), 2006.
- [8] E. T. Baumgartner, H. Aghazarian, and A. Trebi-Ollenu, "Rover Localization Results for the FIDO Rover," in SPIE Proc. Vol. 4571, Sensor Fusion and Decentralized Control in Autonomous Robotic Systems IV, Newton, MA, USA, 2001.
- [9] T. Peynot and S. Lacroix, "Enhanced locomotion control for a planetary rover," in IEEE International Conference on Intelligent Robots and Systems (IROS'03), Las Vegas, USA, 2003, pp. 311-316 vol.1.
- [10] P. Lamon and R. Siegwart, "Wheel Torque Control in Rough Terrain - Modeling and Simulation," in IEEE International Conference on Robotics and Automation (ICRA'05), Barcelona, Spain, 2005, p. 6.