

## The Solar Power Tower Jülich

### A solar thermal power plant for test and demonstration of air receiver technology

Hennecke, K.  
Institute of Technical Thermodynamics  
German Aerospace Center  
D-51170 Köln, Germany  
klaus.hennecke@dlr.de

Hoffschmidt, B.  
University of Applied Sciences Aachen  
Solar Institute Jülich  
Heinrich-Mußmann-Str. 5  
D-52428 Jülich, Germany  
hoffschmidt@sj.fh-aachen.de

Koll, G.  
Kraftanlagen München GmbH  
P.O. Box 201140  
D-80011 München, Germany  
kollg@ka-muenchen.de

Schwarzbözl, P.  
Institute of Technical Thermodynamics  
German Aerospace Center  
D-51170 Köln, Germany  
peter.schwarzboezl@dlr.de

Göttsche, J.  
University of Applied Sciences Aachen  
Solar Institute Jülich  
Heinrich-Mußmann-Str. 5  
D-52428 Jülich, Germany  
goettsche@sj.fh-aachen.de

Beuter, M.  
Kraftanlagen München GmbH  
P.O. Box 201140  
D-80011 München, Germany  
beuterm@ka-muenchen.de

Hartz, T.  
Stadtwerke Jülich GmbH  
An der Vogelstange 2a,  
D-52428 Jülich, Germany  
t.hartz@stadtwerke-juelich.de

#### ABSTRACT

The open volumetric receiver technology allows the use of air as heat transfer medium at high temperatures in solar thermal power tower plants. It combines porous ceramic or metallic absorber structures with a strictly modular receiver design. Highly concentrated solar radiation is used to produce hot air as 'firing' for a steam rankine cycle. The advantages of this technology are simplicity and scalability, the ability to include a thermal storage, the low thermal capacity and a high efficiency potential. This receiver technology was developed in various joint projects of research and industry over the past years. It was tested and qualified in the worlds largest test center for concentrating solar power, the Plataforma Solar de Almería (PSA) in Southern Spain with a nominal power of 3 MW incident radiation. In June 2006 it was decided to build a tower power plant with thermal storage in Jülich, Germany, with a design power of 1,5 MWe. The objectives of this plant are to test and demonstrate the solar air technology as a complete system, to develop control and plant management

strategies and to improve the overall performance and reliability. The location in Germany was chosen as it is close to the research institutions involved and it allows the investigation of the system performance under fluctuating irradiation conditions. The Solar Power Tower Jülich is scheduled to start operation by the end of 2008. The five year project comprises design, construction and a two year test operation phase, accompanied by an intensive R&D program. The experiences of this project will be a vital step towards a successful market introduction.

The paper explains the fundamentals of the open volumetric receiver technology and shows the history of its development. It gives technical information about the system definition and the engineering of the Solar Power Tower Jülich.

#### 1. INTRODUCTION

Solar thermal power plants are a recognized option for large scale renewable electricity production. In these systems,

direct solar radiation is concentrated onto an absorbing surface, where it is transformed into heat at high temperature levels, which in turn is used in a thermodynamic cycle driving a generator to produce electricity. Dispatchable power can be provided to the utility grid by means of integrated thermal storage and/or fuel based back-up systems.

First commercial success was achieved in the late 1980's with 354 MWe of parabolic trough power plants installed in California, which are still in operation and provide some 500 GWh/a to the grid. Recently, increasing environmental awareness and favorable legislation led to a restart of solar thermal power in Spain, which marks the development of world wide markets.

In the Global Market Initiative (GMI) an increasing number of countries co-operate in the aim to realize 5000 MWe of solar thermal power plants by 2015, some estimates predict up to 40 GWe by 2025. This huge market potential opens opportunities for new players and technologies to enter the competition. One of these technologies at the verge of the market is the open volumetric receiver. The solar power tower Jülich, a 1,5 MW pilot plant, is the next logical step in the development and will be the reference for future commercial applications.

## 2. THE SOLAR POWER TOWER JÜLICH

### 2.1 System Concept

Slightly curved mirrors, so called heliostats, track the sun in two axes to concentrate the light onto the receiver located on a central tower. In principle, temperatures above 1000°C can be achieved in the focal area, indicating the high thermodynamic potential of the system. Air was chosen as the heat transfer medium, since it is freely available, non-toxic, and does not require freeze protection during times of non-operation.

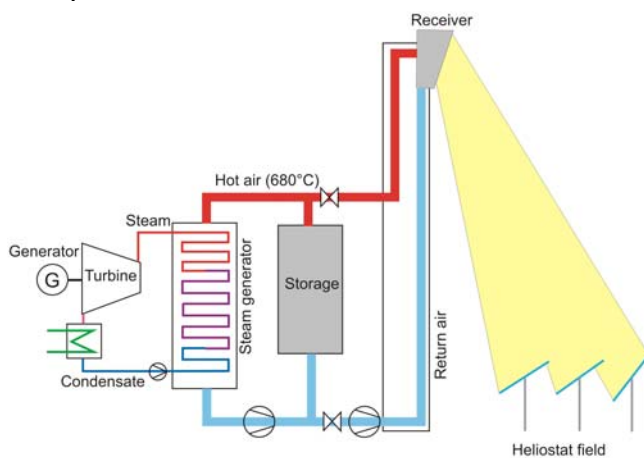

Fig. 1: Schematic of plant concept

The air is heated up to about 700°C and used to generate steam in a waste heat boiler. Steam parameters may be up to 100 bar and 500°C, which is in the typical range for medium-sized conventional power plants. The steam drives a turbine/generator and returns in form of condensate to the steam generator. A thermal storage is connected parallel to the boiler. When charging, hot air passes through the vessel filled with ceramic material, which develops a temperature profile between the hot and the cold end of the storage. The cool air exiting the steam generator and/or storage is returned to the receiver. To discharge the storage, cool air from the steam generator is circulated in reverse flow through the storage vessel and back to the steam generator.

This system concept offers several benefits. Operation with steam parameters as customary in conventional power plant engineering ensures high efficiency and optimum use of the solar energy available. Major parts of the plant can be built using standard components from conventional power plant construction. Design, operation and maintenance concepts can benefit from the sound knowledge base from this sector and consequently, a high operational reliability and availability can be expected. However, the exploitation of these benefits needs an appropriate receiver technology.

### 2.2 Key Component Receiver

Due to the thermo-physical properties of air, large surfaces are necessary to enable efficient heat transfer. This is a certain contradiction to the design requirement of a receiver for highly concentrated radiation, which should have a small aperture area to reduce thermal losses. The solution is provided by the volumetric receiver: The aperture is not the absorbing surface, but allows the concentrated radiation to enter into a porous structure which is heated up and provides huge internal surfaces for the heat transfer to the air, which is sucked through this structure from the ambient.



Fig. 2: Ceramic absorber module

An early development with wire mesh as absorber material was initiated by Fricker (1) and led to tests of a 2,5 MWth receiver on the Plataforma Solar de Almería in the early 1990's under the leadership of the PHOEBUS-TSA project consortium (2). Building on these experiences, systematic

development of ceramic absorber structures at DLR (3) led to the present modular HiTRec receiver design.

The core element is the absorber module made from SiSiC and consisting of an extruded parallel channel structure inserted into a cup (Fig. 2). The inner surface of this structure is about 50 times larger than the aperture. The open neck of the cup is inserted into a double walled steel casing, which is open to the hot air duct. Inside the casing, return air cooling the steel structures is distributed and blown out to the receiver front between the individual absorber modules to be re-circulated through the receiver (Fig. 3). Over a series of development projects, this concept was further refined until a 6 m<sup>2</sup> prototype was developed and tested on the Plataforma Solar de Almería in international co-operation within the EU-Project SOLAIR (2000-2004) (4).

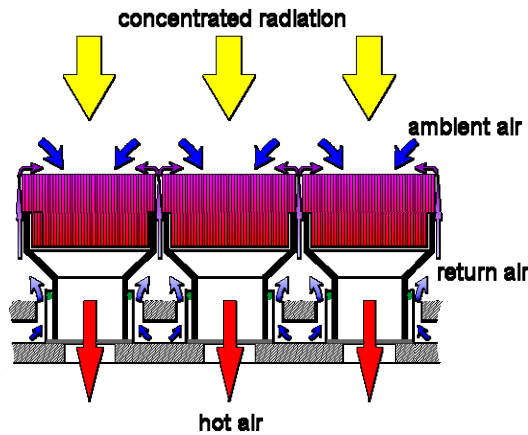

Fig. 3: HiTRec receiver design

This prototype is assembled from 12 subunits which in turn are build up from 27 absorber modules and related casings. At full load at 700°C, this receiver has a thermal power of about 2.500 kW. Up-scaling to larger systems is possible by using similar units as sub-receivers (Fig. 4).

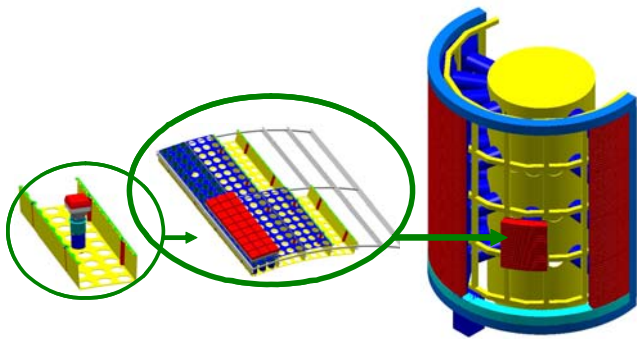

Fig. 4: Modular up-scaling to large receivers

After licensing the technology to Kraftanlagen München, the subsequent joint development was focused on the qualification of the absorber modules and refinement of the receiver design. Detailed investigations regarding the influence of design variations on thermo-mechanical durability, efficiency and cost of the absorber elements were carried out. A parabolic dish concentrator was modified to enable accelerated cyclic loading of individual absorber modules under real operating conditions (5). The prototype receiver was equipped and tested with improved absorber modules, and FEM calculations were carried out to identify critical stresses under different operating conditions. This work created a basis on which the design and realization of a first pilot plant could be endeavored.

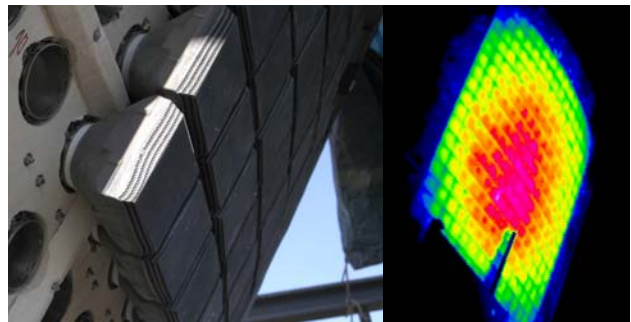

Fig. 5: Prototype receiver during assembly (left) and IR photograph during operation (right)

### 2.3 The Consortium

Stadtwerke Jülich, the municipal utility of the city of Jülich located in the west of Germany will be the owner and operator of the pilot plant. Their engagement in this innovative project is supported by the city council as part of the urban development in this region traditionally related to energy technologies.

Kraftanlagen München, one of the leading German companies in the piping systems and plant construction sector, will be the turn-key contractor. They have taken a license from DLR and see the pilot plant as the logical next step to prepare the technology for the market.

The Solar Institute Jülich at the University of applied sciences Aachen has earned great merits in the development of the project. A long term co-operation is envisaged with respect to research and training of young engineers.

DLR has developed and licensed the receiver technology to KAM and contributes to the design, start-up and operation of the plant. In the accompanying R&D program, further improvements of the technology and methods for optimized operation and quality assurance will be developed.

## 2.4 Pilot plant design

To be able to serve as a reference for future commercial systems, the pilot plant needs to be rated in a power range significant for utility applications, but at the same time be small enough to keep technical and financial risks low. A turbine capacity of 1,5 MWe was chosen as basis for the design. Heliostat field and receiver tower design were adapted to the latitude and boundaries of the selected site with a ground area of about 160.000 m<sup>2</sup>. About 20.000 m<sup>2</sup> of Heliostats will be installed. The receiver with an aperture of 22 m<sup>2</sup> will be mounted at a tower height of 55 m.

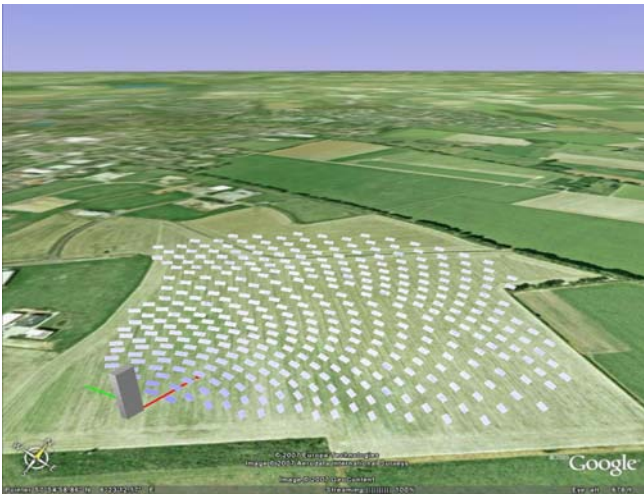

Fig. 6: Selected site with possible heliostat field layout (montage)

Except for the cooling towers, the complete power plant equipment and offices will be accommodated inside the tower.

## 2.4 Project status and outlook

Approval planning is complete, and detailed design of the plant has started. Site work shall commence summer 2007, and start-up is scheduled for late 2008. After a two year period of operational testing, the plant shall generate electricity for the grid in a regular manner. In parallel, the research partners will monitor the plant performance and use the opportunity to further advance the technology. A medium to long term option under consideration is the hybridization of the plant with bio-fuel. It is expected that the successful demonstration of the pilot plant operation will lead to commercial follow-up projects in suitable locations in the sunbelt of the world.

## 3. NOMENCLATURE

DLR Deutsches Zentrum für Luft- und Raumfahrt  
(German Aerospace Center)

e	electric
EU	European Union
FEM	Finite Element Method
GMI	Global Market Initiative
GW	Gigawatt = 10 <sup>9</sup> Watt
KAM	Kraftanlagen München
kW	Kilowatt = 10 <sup>3</sup> Watt
MW	Megawatt = 10 <sup>6</sup> Watt
PSA	Plataforma Solar de Almería
R&D	Research and Development
SIJ	Solar Institute Jülich
SiSiC	Silicium infiltrated Silicium carbide
th	thermal

## 4. ACKNOWLEDGMENTS

The technology development was supported through a series of projects with funding from the European Commission, the Federal Republic of Germany and the State of North Rhine-Westphalia.

The current project for the realization of the pilot plant is supported by the Federal Ministry for the Environment, Nature Conservation and Nuclear Safety, the Ministry of Economic Affairs and Energy of the State of North Rhine-Westphalia, and the Bavarian Ministry of Economic Affairs, Infrastructure, Transport and Technology .

The authors gratefully acknowledge the co-operation and financial support.

## 5. REFERENCES

- (1) H.W. Fricker, M. Silva, C. Winkler and J. Chavez, "Design and Test Result of Wire Receiver Experiment – Almería" 4th International Solar Energy Conference, Santa Fe, NM, 1988
- (2) M. Haeger, L. Keller, R. Monterreal, A. Valverde, "PHOEBUS Technology Program Solar Air Receiver (TSA) – Operational Experiences with the Experimental Set-Up of a 2,5MWth Volumetric Air Receiver at Plataforma Solar de Almería" Ciemat-DLR Plataforma Solar de Almería. PSA-Technical Report 02/94, 1994
- (3) B. Hoffschmidt, „Vergleichende Bewertung verschiedener Konzepte volumetrischer Strahlungsempfänger“ Dissertation RWTH Aachen. DLR-Forschungsbericht 97-35. Köln, 1997
- (4) B. Hoffschmidt, G. Dibowski, M. Beuter, V. Fernandez, F. Téllez, P. Stobbe, „Test Results of a 3MW Solar Open Volumetric Receiver“, ISES Solar World Congress 2003, Göteborg, Sweden, 18.06.2003
- (5) M. Ebert, G. Dibowski, M. Pfänder, J.-P. Säck, P. Schwarzbözl, S. Ulmer, „Test Facility for Volumetric Absorber“ Proceedings of 13th SolarPACES Symposium, June 20-23, 2006, Seville.