

**CASE STUDIES IN THE USE OF COMPUTER SOFTWARE
IN THE TEACHING OF ENERGY**

Thesis submitted in fulfilment of requirements for the degree of

D O C T O R O F P H I L O S O P H Y

by

G M NICHOLLS

Department of Science Education
University of London
Institute of Education

January 1991

ABSTRACT

The project was designed to investigate how a piece of software could be used in the teaching of Energy. The central aim of the research was to show how the incorporation of software in the teaching of energy is dependent on a variety of factors, notably pupil's cognitive levels, and their underlying conceptions of energy.

The subjects of the study were four classes consisting of three age groups, who participated in a six week energy project.

The data consisted of:

- (a) A special purpose conceptual questionnaire;
- (b) CSMS Science Reasoning Tasks;
- (c) Observations during teaching;
- (d) Pupils work during teaching;
- (e) Data about pupils from teachers and school records.

The questionnaire was given to pupils before and after teaching. From an analysis of the results it was possible to describe a structure of pupil's conceptions of Energy. Three of the classes were given Piagetian tests to establish pupil's cognitive levels, as a possible way of predicting problem areas that might occur in the use of the software. Observations of the interaction between pupils and the computer were made and used to develop teaching strategies. Detailed records of the pupil's project work were collected. The analysis of this work was made through:

- 1 A "systemic" network, that characterised pupil's conceptions of Energy from their written work;
- 2 A comparison of the cognitive level (on Piagetian lines) of the written work and the cognitive demands of the tasks set through the software;
- 3 A comparison of cognitive levels on SRTs and cognitive level as evidence in pupil's work and in their conceptions;
- 4 In certain cases, data about pupils was obtained from the teachers and school records to substantiate the results found in the analysis.

In so doing, some of the influences on the learning and teaching of energy with the use of a piece of software have been explored.

ACKNOWLEDGEMENTS

I dedicate this thesis to the memory of my father for without his encouragement in the first instance it would never have been attempted, and whose wish it was to be completed.

I am indebted to Jon Ogborn for his excellent supervision, continuous support, encouragement and patience, sometimes in the most difficult of situations; to Roger Wolfe and Wendy Matthews, whose support and good humour were invaluable; to Vince Stribbling, Julie Stribbling, and Gill Stowe, from British Gas South Eastern, who were always there to help with resources, advice, demonstrations in schools, and most of all encouragement and humour, to Dick Boohan for his endless help in the computer work, to the teachers and schools that made the research possible; to Margaret Walker for caring for my children in my absence; to Helen Tweedle whose encouragement, help in the Primary schools, and belief in the project has been wonderful; and finally to my husband whose loyalty, sense of humour and support have never faded.

The project was part of a collaboration between British Gas (HQ) Education Service and the Science Department of the London Institute of Education.

CONTENTS

PAGE

ABSTRACT

ACKNOWLEDGMENTS

CONTENTS

FIGURES

TABLES

CHAPTER 1 INTRODUCTION 1

- 1.1 Teaching and learning of energy using computer software 1
- 1.2 Goals of the Research 6

CHAPTER 2 PRELIMINARY AND PILOT WORK 7

- 2.1 Introduction 7
- 2.2 Development of Software Catalogue 7
- 2.3 Choice of Computer Software 9
- 2.4 Primary Energy Game (PEG) 11
- 2.5 CEDRIC 2.1 13
- 2.6 Preliminary Investigations and Pilot Work 14
 - 2.6.1 Using PEG 15
 - 2.6.2 Using CEDRIC 2.1 18
- 2.7 Some Conclusions 19

CHAPTER 3 CEDRIC 2.1 21

- 3.1 Introduction 21
- 3.2 Background of the Development of CEDRIC 2.1..... 21
- 3.3 Scope and Use of Program 22
- 3.4 What the Program Does 23
- 3.5 Detailed Description of Each Program 24
- 3.6 Basic Research Questions for the use of CEDRIC 2.1 in the Classroom..... 30

CHAPTER 4 LITERATURE REVIEW 31

- 4.1 Introduction 31
- 4.2 Computers in Education 32
- 4.3 Teaching and Learning 38
- 4.4 Childrens Ideas on Energy 50
- 4.5 Cognitive Development 54
- 4.6 Overview 60

CHAPTER 5 RESEARCH QUESTIONS 63

- 5.1 Introduction 63
- 5.2 Questions raised 63
- 5.3 Assumptions made in research for the use of CEDRIC 2.1 68

CHAPTER 6	<u>WORK CARRIED OUT and DATA COLLECTED</u>	70
6.1	Overview of the Research	70
6.2	Formulation of Energy Questionnaire	75
6.3	The Energy Project Carried out in Schools	80
6.3.1	Introduction	80
6.3.2	Points Common to all schools	80
6.3.3	Primary School 1	82
6.3.4	Primary School 2	86
6.3.5	Secondary School 1	91
6.3.6	Secondary School 2	94
6.4	Extension Work on CEDRIC 2.1	96
6.5	Science Reasoning Tasks	96
6.6	Overview	99
6.7	APPENDIX to Chapter 6	100
CHAPTER 7	<u>DATA ANALYSIS: ENERGY QUESTIONNAIRE</u>	107
7.1	Introduction	107
7.2	Energy Questionnaire	107
7.3	Rationale	107
7.4	Analysis of Data	108
7.4.1	Analysis of Questionnaire Prior Teaching	110
7.4.2	Analysis of Questionnaire Post Teaching	126
7.5	Some Conclusions	133
CHAPTER 8	<u>DATA ANALYSIS: CSMS TASKS AND ANALYSIS OF CHILDRENS WORK</u>	135
8.1	CSMS Tasks	135
8.1.1	Introduction	135
8.1.2	Analysis	136
8.1.3	Looking at the SRT's alone	142
8.1.4	General Expected Level of Achievement based on SRT's	143
8.1.5	Individual Differences	149
8.1.6	Discussions of outcomes from the SRT's	153
8.2	Analysis of Children's Work	155
8.2.1	Introduction	155
8.2.2	Rationale	156
8.2.3	Analysis	156
8.3	Analysis Through Tasks	170
8.3.1	Some Conclusions	179
8.4	Looking at the Pupils Ideas of Energy in Relation to their Cognitive Level	181
8.4.1	Summarising the Data	181
8.4.2	Analysis	182
8.4.3	Some Conclusions	190
8.5	Considering The Secondary School Pupils	191
8.5.1	Introduction	191
8.5.2	Rationale	191
8.5.3	Analysis	192
8.5.4	Some Conclusions	199

	PAGE
CHAPTER 9 CONCLUSIONS	200
9.1 Introduction	200
9.2 Summary	201
9.3 Pupils Conceptions and Cognitive level: Is there a Link? ...	201
9.4 Cognitive Level and Conceptual Demand: Is there a Link?	203
9.5 Teaching and Learning	204
9.6 Final Comment	206

BIBLIOGRAPHY

APPENDICES

1	Software availability Catalogue 1987/1988
2	CEDRIC 2.1 Original Household Data Sheet
3	Energy Questionnaire
4	Questions set to Primary and Secondary Schools
5	Record of Pupils responses from Primary and Secondary Schools
6	Revised Data Collection Sheet 1
7	Revised Data Collection Sheet 2
8	Revised Data Collection Sheet 3
9	Revised Data Collection Sheet 4
10	CSMS Tasks Sheets
11	"Holming in on Home Heating"
12	Pupils responses to Energy Questionnaire
13	Cognitive Level attained by pupils in Class 1a, 1b and Class 3
14	Cognitive Level Scaling
15	Complete Curriculum Analysis Taxonomy
16	Responses to Energy Conservation Questions
17	Energy Efficient House
18	Energy Paper "Dimensions of Childrens' Conceptions of Energy"
19	Multidimensional Scaling (MDS)

FIGURES

PAGE

2.1-1	Energy Software Available Autumn Term 1987	8
3.1-1	Flow Chart for CEDRIC 2.1	27
6.1-1	Objects Used for Energy Questionnaire	78
6.7-1	CEDRIC 2.1 Household Data Collection Sheet 1	102
6.7-2	CEDRIC 2.1 Data Collection Sheet 2	104
7.4-1	Aspects of Energy Questionnaire	108
7.4-2	Objects used in Energy Questionnaire	109
7.4-3	Multidimensional Scaling Map for Younger Pupils	111
7.4-4	Percentage Yes Answers for Younger Pupils	113/114
7.4-5	Dot Plots for Younger Pupils	118/119
7.4-6	Interpretation of two Dimensions	121
7.4-7	Multidimensional Scaling Map for Older Pupils	111
7.4-8	Percentage Yes responses for Older Pupils	123/124
7.4-9	Multidimensional Scaling Map for Younger Pupils Post Teaching	127
7.4-10	Percentage Yes responses for Younger Pupils Post Teaching ...	130
7.4-11	Multidimensional Scaling Map for Older Pupils Post Teaching	127
7.4-12	Percentage Yes responses for Older Pupils Post Teaching	132
8.1-1	Shayer, Percentage of Children at Various Stages	137
8.2-1	First attempt of Energy Network	158
8.2-2	Possible Interaction of entities	158
8.2-3	Final Version of Energy Network	159
8.2-4	House Design 1	176
8.2-5	House Design 2	177

TABLES

PAGE

6.1-1	Types of Data Collected	74
7.1a	Dot Plot Analysis	116
7.1b	Summarising the Nature of Objects	117
7.2	Object Characterisation	120
7.3	Aspects which distinguish Entities	121
7.4	Differences between Groups	125
7.5	Comparison of Weightings from MDS maps Post and Pre Test	128
8.1-1	Cumulative Percentages for National Average	138
8.1-2	Number of Pupils in each Class Obtaining Cognitive Level	138
8.1-3	Chi-Squared Test for Classes 1a, 1b and 3	139/140/141
8.1-4	Curriculum Analysis Taxonomy. Section 1.1 to 1.6	144
8.1-5	Curriculum Analysis Taxonomy. Section 2.1 to 2.9	145
8.1-6	Curriculum Analysis Taxonomy. Section P1 to P12	146
8.1-7	Example Results Sheets	150
8.1-8	Degree of Difficulty Found	154
8.2-1	Number of Pupils at each Cognitive Level	167
8.2-2	Work is Expended Energy	167
8.2-3	Energy has Many Sources	168
8.5-1	Energy Topic/Cognitive Level	196
8.5-2	Reasons for Events	197

CHAPTER: 1 INTRODUCTION

1.1 TEACHING AND LEARNING OF ENERGY USING COMPUTER SOFTWARE

It is more than a decade since the first publications about children's prior ideas and conceptions with relation to teaching first appeared, leaving researchers and teachers asking questions about how to incorporate these notions into effective teaching strategies. Running concurrently with this has been the advent of the computer into the classroom, adding to the need for research into how best to view its use and into how to include it in the everyday teaching of science and other areas of the curriculum. There have been various projects on possible uses of computers in the classroom, such as LOGO or wordprocessing, as there have been projects to consider how best to use childrens' prior conceptions in practical teaching situations, eg (CLISP) (Centre for Studies in Science and Maths Education, University of Leeds. 1987)

This study is specifically concerned with the integration of a piece of software into the teaching and learning of energy and energy related concepts. It is a set of case studies, using a specific set of teaching strategies, and a particular program (CEDRIC 2.1). The study hopes to clarify the possibilities of using such a piece of software within an integrated teaching scheme and to identify gaps between intended and actual outcomes, by pinpointing the problems and issues connected with such an endeavour.

Two major problems arise from the nature of the project:

- (a) The type of software to be used;
- (b) The nature of the subject matter, Energy.

These two problems each involve several issues. The first problem concerns the availability of suitable software and the process of choosing which software packages would be most suitable to use within the main body of the research. The second problem concerns the nature of the subject matter to be taught. Energy is a very abstract concept that holds a variety of meanings for adults and pupils alike, not always in agreement with the scientific view. This gives rise to the possibility that pupils hold very definite prior conceptions of energy that might influence the way they approach the teaching and learning of energy in school. Added to this is the possibility that the conceptual demands of energy related topics do not match the conceptual levels of the pupils, in this way causing problems.

The main purpose of the project was to see how computer software could be incorporated into the teaching of energy. Before considering issues about prior conceptions and cognitive level, it was necessary to consider what software was available for teaching. The decision to use one piece of energy software, and the way in which it was chosen forms the subject matter of Chapter 2. Chapter 3 gives a detailed description of the chosen

software, CEDRIC 2.1. The chapter concludes with a statement concerning some of the basic questions that guide the research.

Four such questions are given:

- 1 Can pupils aged 9 to 13 learn about energy by using CEDRIC 2.1?
- 2 What teaching material/strategies can help make CEDRIC 2.1 part of an effective sequence?
- 3 What can be learned about the appropriateness of CEDRIC 2.1 in this context?
- 4 How important is cognitive level, as opposed to knowledge, in determining the success of the learning tasks within CEDRIC 2.1?

These questions are elaborated and clarified in Chapter 5.

Chapter 4 reviews the literature relevant to the study of the learning of energy, using software. It is divided into four areas, each considering issues that have a bearing on the present research.

- 1 Computers in Education.
- 2 Teaching strategies and classroom learning.
- 3 Children's ideas on Energy.
- 4 Cognitive development and demand.

The work carried out and the data collected are described in Chapter 6. An overview of the research is given by describing the four schools used and the nature of the work undertaken in them. The question of prior conceptions is considered, with a description of the development of an energy questionnaire which attempts to find some structure in the way pupils between the

ages of 9 to 13 think about energy, in this way giving direction to teaching strategies. Four schools were used, two Primary and two Secondary schools. The aim was to try the software out with a cross-section of ages, abilities, and cognitive level, in this way trying to ascertain the types of teaching strategies required for the software.

Much of the data collected was of a qualitative nature, in the form of pupils' written work, tape recordings of classroom discussions, and assignments, all of which are discussed in detail. Finally a description of each school's project work is given with comments from teachers and pupils involved. Development of teaching aids evolving from the projects can be found in the appendix to Chapter 6.

Analysis of the data collected is considered in Chapters 7 and 8. It is divided into three main sections:

- 1 Energy questionnaire - This aimed at finding a possible structure in the way pupils conceive energy at the various ages considered, and to see if there are important differences between them that could be accounted for, either through teaching/learning experiences or cognitive level.
- 2 The CSMS tasks (cognitive level). The cognitive levels of the pupils and the cognitive demands of the software are both examined in the light of the work done by Shayer and Adey (1981). Their curriculum taxonomies are used

to try to predict possible areas of difficulty within the software. The levels of cognition as described in the taxonomies are then used to examine a selection of topics considered as difficult, in conjunction with the individual results of the pupil's cognitive levels obtained from CSMS tests, [Shayer and Wylam (1978)], to see if there is a correlation between those topics well or poorly understood, and the levels of cognition supposed to be required for them.

3 Analysis of children's work. In order to extract as much information as possible from the pupil's work, it is analysed in three ways:

- (a) Development of a network to analyse the children's conceptions of energy from their own work;
- (b) Seeing how far the pupil's work reflects their cognitive levels;
- (c) Seeing if there is any relationship between the results of the CSMS tasks and those of the energy questionnaire.

Chapter 9 draws together the points raised by the analysis of the data. It discusses possible connections between prior conceptions, cognitive level, and the teaching/learning of energy. These views are then brought together with suggestions for how the research could be further developed, in an effort to help identify areas of software and teaching/learning strategies that require improvement, in this way producing information of potential value to a teacher who may intend to use such software.

1.2 GOALS OF THE RESEARCH

In the light of the research questions raised in Chapter 5, the study sets out to accomplish the following:

- 1 To review available energy software, with respect to its possible use in teaching strategies;
- 2 To confirm that pupils do have prior conceptions of energy;
- 3 To identify a possible structure in these notions that could influence teaching strategies;
- 4 To see if software can be analysed for cognitive demand, and whether this can be related to the cognitive levels of pupils;
- 5 To see if prior conceptions have any relationship with the cognitive level of the pupil;
- 6 To see if teaching strategies can be evolved using such information to the benefit of both teacher and pupil;
- 7 To demonstrate the possible use of computer software within an integrated teaching scheme.

CHAPTER: 2 PRELIMINARY AND PILOT WORK

2.1 INTRODUCTION

This chapter explains how the pilot and preliminary work was conducted, in order to investigate teaching strategies and learning experiences with respect to energy related software. It shows how the software was chosen for the main body of the research.

2.2 DEVELOPMENT OF SOFTWARE CATALOGUE

It appeared useful to begin by finding a way of collecting information concerning the type and availability of Energy related software. This was necessary in order that a decision could be made as to which software packages would be most useful for the research. It was also important to have this information so as to be able to consider what form of evaluation might be appropriate. Thus all the available software was documented in the form of a catalogue.

This information was collected by going through all Educational software catalogues, as well as approaching industries concerned with energy such as British Gas, Shell, BP, and CEGB. This showed both a lack of Energy software available at the time, and the diversity of that which existed, as can be seen in figure 2.1.1.

Figure 2.1.1

ENERGY SOFTWARE AVAILABLE AUTUMN TERM 1987

SUBJECT AREA	SUGGESTED AGE RANGE
Energy first series project	6 to 9
Electricity Softlab	6+
Primary Energy Game	9 to 11
Heat and Temperature	11+
CEDRIC 2.1 (Home insulation)	11 to 14
Watts in Your Home	11 to 16
Nuclear Reaction Simulation	14 to 18
BP Energy Pack	15 to 18
Power Package	15+
Domestic Heating	Secondary level
Micro Gas Class	5+

Each piece of software was looked at and analysed under the following headings:

- 1 Type of software.
- 2 Program classification.
- 3 Intended program user.
- 4 Subject classification: Area of the curriculum to be covered.
- 5 Scope of program.

6 Interaction with program.

7 Overall impression.

The catalogue was intended to be a way of looking at the software on a descriptive level. It aimed to analyse each program in a way that would be useful to a teacher who was looking for a range of software options that would give a distinctive contribution to a course or area of study in the curriculum. (A full copy of the catalogue can be seen in Appendix 1).

The catalogue was printed, packaged and sent to various schools throughout Britain, with a simple questionnaire attached asking for teachers' comments. The return was low but useful.

2.3 CHOICE OF COMPUTER SOFTWARE

The aim of the catalogue had been to see what type of Energy software was available, so as to decide what software to use in the research. It seemed, given the small quantity of software and its diversity, that it would be more appropriate to concentrate on two or three specific pieces of software that appeared to have similar content. In this way it was hoped that related aspects could be chosen in order to try to investigate them with respect to learning processes, knowledge and skills required, cognitive level, and applicability to various age ranges.

When choosing the software it was necessary to consider the nature of the problem, in that the software had to fit within a framework of Energy teaching in schools, and be suitable for

pupils in Secondary and Primary schools. It was also hoped that one of the software packages would be a British Gas production, as they were interested to see how their Energy software functioned within a given classroom setting. This interest arose as a part of their collaboration within the research work.

Several factors contributed to the decision to use two programs: Primary Energy Game (PEG), and CEDRIC 2.1 (Community Energy Data and Retrieval Information). Initially the programs were selected for the similar ideas and concepts they appeared to portray. Both were based on home heating and the conservation of fuel within a household setting. The programs used these ideas in different ways. PEG is a game designed for 9 to 11 year olds and CEDRIC 2.1 is a database aimed at the 11+ age group. This slight overlap of target ages, but difference of approach, was thought to be useful.

PEG and CEDRIC 2.1 were given some preliminary tests in schools, each with two or three children, looking at whether they could use the program on their own and understand what it was trying to say. In addition, the preliminary work looked at the acceptability of the programs within the school situation, with respect to teachers' views, and the place they thought the software might have within a given teaching context. From the results the programs appeared to be sufficiently compatible with one another in related concepts, but diverse enough in approach, to attempt pilot work with them.

As previously mentioned, both software packages related to energy consumption within a domestic setting, but portrayed it in different ways. It is now appropriate to consider each.

2.4 PRIMARY ENERGY GAME (PEG)

PEG is a game in which the user tries to control the internal temperature of a house in response to a set of random events. The documentation of the software makes claims about the value and purpose of the program which could be tested by using this software over differing age ranges. The documentation claims that:

"PEG is a program that was developed so that young children are introduced to the principles of good household practice in a challenging and entertaining manner PEG has been designed for children in the age range of 9 to 11 although it has an educational value for a much wider age range".

[Introduction to PEG documentation (1986) p2]

The program involves a person, PEG, controlled by the pupil, who can turn radiators on and off, and open and close doors and windows, in order to maintain the house at a constant temperature. The computer controls the variation of the outside temperature, which is guided by a twenty-four hour cycle and is shown by an outside thermometer, as well as a clock telling the time of the day and night. Added to this, the weather can change, sometimes dramatically from sunshine to snow, which adds variety to the game.

The documentation states that:

"Another element of the game is the random opening and closing of windows by other people, making it more exciting as well as introducing the ideas of ENERGY CONSERVATION PEG has to try to close them before too many points are lost, ie energy is BEING WASTED".

[PEG documentation (1986) p3]

The objectives behind PEG are notably:

"The overall objective of the package is to help the children to be more aware of the importance of domestic heat energy conservation, and the need to control the home environment economically"

"There are also a number of subsumed conceptions within this overall objective that are worth noting as follows:

- 1 The concept of thermostat control
- 2 The concept of thermal equilibrium.
- 3 Differentiation between temperature and heat and the concept of temperature as 'degrees of heat'.
- 4 The concept of conduction of heat.
- 5 The concept of hot-warm-cold being a part of the same continuum.
- 6 Objects in general take time to cool down.
- 7 The concept of heat "spreading", eg leaving the door open heats neighbouring rooms"

[PEG documentation (1986) pp5-6]

These give a good indication of what the PEG program aimed to achieve with pupils. It would clearly be possible in principle to study how well such claims were met, in a realistic classroom context.

2.5 CEDRIC 2.1

The second package chosen was CEDRIC 2.1. This is a database program designed for Secondary school pupils. It is used to calculate the energy consumption of the individual pupil's home and possible areas of energy wastage. The documentation states that:

"CEDRIC 2.1 will help you to think about the way you use energy in your home".

[CEDRIC 2.1 Pupils guide (1987) p1]

The teacher's notes indicate that:

"The program attempts to answer the questions:

- 1 Is my home energy efficient in terms of thermal insulation?
- 2 What energy saving methods are best suited to improve the situation?"

[CEDRIC 2.1 Teachers notes (1987) p2]

CEDRIC 2.1 tackles these questions using three main programs:

- 1 PROFILE: This contains a lot of facts and figures about different kinds of homes in the United Kingdom, and how they use energy. You can then compare your own sample of homes with this data.
- 2 DHL (Designed heat loss): This calculates how much energy escapes from the home on a cold winter's day.
- 3 GUESTIMATOR: This estimates the quantity and the cost of the energy used for different purposes in the home.

These three programs are meant to be used to teach pupils various aspects of energy saving. The documentation states that:

"In Physics the topics of energy conservation and heat transfer can be related to the very practical problem of thermal insulation of the home. CEDRIC 2.1 provides an excellent introduction to the concepts of thermal equilibrium, the core concept upon which the program is based the topics of home insulation, choice of fuels for heating, transfer and conversion of energy and so on, can be taught in an entirely relevant manner".

[CEDRIC 2.1 Teachers notes (1987) p1]

Other claims made by CEDRIC 2.1 include:

" The program provides for an excellent practical exercise in data collection, processing and presentation as well as introducing concepts of energy conservation in the home the program involves the children in measuring in metric units and calculating areas and volumes".

[CEDRIC 2.1 Teachers notes (1987) p1]

From these statements it can be seen that there is much similarity in what is intended to be taught by PEG and CEDRIC 2.1. The work for pupils that accompanies CEDRIC requires mathematical and measurement skills to collect data and make calculations so as to proceed through the program, (see Chapter 3). PEG, however, requires only qualitative decisions to be made by the child.

2.6 PRELIMINARY INVESTIGATION AND PILOT WORK

In order to investigate in a preliminary way how the two programs could be used in the classroom, it was necessary to ask some very basic questions about the program. These questions as initially formulated were:

- 1 Does the software do the job intended?
- 2 Does the software have an identifiable position in the curriculum, or teaching strategy of the teacher, ie is there a job for the software to do?
- 3 What type of tasks are necessary to be able to obtain reliable information about how much the learner really knows in a given area?

With these questions in mind the two programs were taken into two Primary and two Secondary schools. The same schools were later used for the research, and will be discussed in detail in Chapter 6.

2.6.1 Using PEG

The first piece of software to be examined was PEG. This was designed for the Primary school, yet it was received poorly by the two Primary schools as well as by the Secondary schools. I took groups of children and introduced them to the computer program. Each group had a double session of approximately 60 to 80 minutes with me. It was evident from watching the children that the program was being used more as a game than as an instructional instrument, and it was difficult to assess whether any learning was taking place. This can be seen from the children's comments after using the program. In what follows, Groups 1 and 2 were children from the fourth year juniors in Primary school one. They were high ability pupils who through selection were going to Grammar school. Groups 3 and 4 were mixed ability groups from the second Primary school.

GROUP 1

"We thought this game was fun to play with, but it didn't teach us as much as we thought it would".

On questioning the pupils it became noticeable that some of the basic concepts of the game were being misunderstood. For example, pupils realised that they were trying to keep the house warm, but could not understand the logic of the program, as their comments indicate.

GROUP 1

"There were some things we could not understand, eg the windows kept opening and closing at inconvenient moments. The thermometers also changed even at high temperatures to low - even though the radiators were on and the windows closed".

Group 2

"The game wasn't realistic enough to teach us about the advantages of saving energy in the home. In one sense that the windows opened by some magic force and lowered the temperature in the room also that when you turn the radiators on they automatically switch onto full temperature so raising the climate in the room also the sudden change of weather, because in a real situation the sun would never change to snow in about a couple of seconds".

(This statement comes from a 10 year old)

GROUP 3

"The game was not set in realistic position, an example is that the windows kept opening and when you turned the radiators it lit up straight away the sudden change of the weather without warning was not a good idea".

My observation of pupils using the PEG program suggested that the pupils appeared to be more engrossed in the game

than trying to see what was actually making the game work. The gaining of points seemed to predominate, whoever was at the keyboard.

The above comments taken from pupils seem to reinforce the impression that they were puzzled about reasons for the effects of windows opening and doors closing etc. It appeared that they were simply reacting to what happened, and not being led to think about why each thing happened, or why their actions had the effect they did. After each group of pupils' had used the program, I started a discussion with them about what they thought the program was trying to teach them. This made it clearer that they had not grasped the basic concept of the program, ie that of the conservation of heat within the home.

The discussion was taken a stage further. I got one pupil to sit in front of the computer, and the other pupils to give him instructions as to how to control events. At the same time they also tried to explain to each other what was happening eg windows opening would lead to a temperature drop. Two reasons were given:

- (a) That the room was too hot and the radiators needed to be turned off, in terms of points to be gained in the game;
- (b) A random event, in which case the windows had to be shut and the radiators turned on.

Gradually the pupils seemed to become aware that the events occurring on the screen related to the overall structure of the game, hence controlling the score they could achieve in the game. After this period of joint work I asked the group to discuss the points raised and to write a new comment on the program. A typical example is given by Group 4:

GROUP 4

"PEG had to try to keep his house at an even temperature, through night and day, sun and rain, and make sure energy wasn't wasted. It made Thalia and I quite frustrated because every time we shut a window and our score would start building up, a radiator downstairs would turn on and you'd have to remember to shut the door behind you".

2.6.2 Using CEDRIC 2.1

CEDRIC 2.1 was designed for 11 to 15 year olds, (a fuller description of its development and educational content can be found in Chapter 3). It appeared however that it had potential for being used in the Primary school. The same four groups were introduced to the program, in a similar way as described for PEG. It was evident from the way the pupils approached the program that they would need help in understanding the data collection sheets, however once they obtained the relevant information they appeared to understand what was required of them. The pupils' comments on the program reflect this:

GROUP 2

"CEDRIC was a very interesting game. It made me find out a lot about my house that I didn't know. You had to type the information you had found out about your house into the computer and it would process the energy your house wasted".

My observations here, were that the pupils found the program far more interesting than PEG. However CEDRIC was not without its problems, such as the data collection sheets. Nevertheless it appeared to have potential for the teaching of energy.

2.7 SOME CONCLUSIONS

It would appear that although the pupils had some appreciation of PEG, the game element still remained firmly in their minds. This made me realise that to try to see how, or in what way, the pupils were actually thinking about energy would require them to use more skills than were needed in the PEG program. Secondly, as most of the questions were posed by me in order to promote discussion, it was difficult to interpret what the pupils had learnt, and to what extent the program had influenced their thinking. From this point of view PEG appeared too limited for the research work, and this was a contributing factor in the decision not to use it in the main research.

However the preliminary work does suggest that PEG has limited uses for Energy work in the classroom. It appeared that the pupils, given sufficient direction and teaching, could grasp aspects of heat conservation within the home. But this in essence was not what the research was trying to achieve, although it is arguable that a similar line of research could be applied to the PEG program, in terms of knowledge and skills used, learning processes etc.

CEDRIC 2.1 was chosen as it appeared to give more opportunity to test knowledge, skills, cognitive level, and general appropriateness within the classroom situation. Teachers found it more flexible, with the possibility of cross curricula activities, than PEG.

In conclusion, it was decided that CEDRIC 2.1 was to be the software package that would be concentrated on for the main body of the research. Chapter 3 discusses the development and format of CEDRIC 2.1 in detail. Its use in the classroom, and the tasks set and developed from it, and the teaching strategies involved, are all discussed in detail in Chapter 6.

CHAPTER: 3 CEDRIC 2.1

3.1 INTRODUCTION

The purpose of this chapter is to discuss the nature of CEDRIC 2.1 and indicate the basic research questions that its use in the classroom might raise. The chapter begins by giving a background to the development of the program, followed by detailed descriptions of each section and finally discussing the questions that will be looked at in the study.

3.2 BACKGROUND OF THE DEVELOPMENT OF CEDRIC 2.1

CEDRIC 2.1 (Community Energy Display and Retrieval of Information and Calculation) was initially designed as an aid to "Energy Study UK", a national schools competition of the Energy Efficiency Office. The competition was sponsored by British Gas, Conoco and the Electricity Council, and was organised by the regions of British Gas and the Northern Ireland Electricity Service during the latter half of 1984. The object of the competition was to help children understand domestic energy use and energy saving in their individual homes and their local communities.

The popularity of the competition encouraged British Gas Education Service to revise and distribute CEDRIC as a separate teaching package. CEDRIC 2.1 is a major revision of the original.

3.3 SCOPE AND USES OF PROGRAM

CEDRIC 2.1 features a built-in database of regional and national statistics concerned with energy use. In essence the program accepts pupils data and makes comparisons between them and the built-in database. It aims to enable pupils to process data that they themselves have independently collected so that they can draw conclusions about how energy efficient their own homes are, and make suggestions on how to make them more energy efficient. A number of concepts within the field of energy conservation, such as heat flow and thermal equilibrium, are introduced.

The program was designed so that it could be used in various areas of the curriculum. It is suggested by the documentation that in physics the topics of energy conservation and heat transfer can be related to the very practical problems of thermal insulation of the home; as CEDRIC 2.1:

"Provides an excellent introduction to the concept of thermal equilibrium, the core concept of the program".

[CEDRIC 2.1 Teachers Notes (1987) p7]

It also suggests that in a typical middle or lower Secondary General Science course the program provides practical exercises in data collection, processing and presentation as well as introducing the concepts of energy conservation in the home. It maintains that children will experience the use of units in which energy is measured, and will be introduced to the idea that energy has to be paid for.

With respect to Mathematics the program involves the children in measuring in metric units and in calculating area and volume. It therefore provides a very practical application of these concepts, which can be used in a realistic and practical way.

With the advent of the National Curriculum all these suggested aspects of the program feature quite prominently in various attainment targets in both the Science and Mathematics documents as well as the proposals for Technology in the National Curriculum [National Curriculum Documents (1988, 1989)].

3.4 WHAT THE PROGRAM DOES

The program attempts to answer the questions:

- 1 Is my home energy efficient in terms of thermal insulation?
- 2 What energy saving methods are best suited to improve the situation?

It attempts to answer these questions by processing data collected by the pupils in groups or individually. It presents the data both numerically and in graph form, in this way allowing the pupils to make comparisons on both a national and regional level. The "regions" refer to the British Gas Regions in which the children live.

The three main programs making up the packages each contain a data file of the national and regional information.

(a) PROFILE:

Has a data file on specific characteristics of homes, such as property types, age, kinds of insulation, etc.

(b) DESIGNED HEAT LOSS (DHL):

Concerns itself with heat loss and gives an approximate measure for the Designed Heat Loss for each home, and proportion of heat loss through roofs, windows, walls and gaps.

(c) GUESTIMATOR:

Gives an estimate of how much energy a particular home, with its own pattern of energy use, could typically be expected to use in a specific region. This can then be compared with the actual energy use, and inter-regional comparisons, so that conclusions can be drawn by pupils.

The documentation claims that:

"It can be seen that by using the programs either individually or in tandem, a great number of questions under the umbrella of energy conservation can be answered".

[CEDRIC 2.1 Teachers Notes (1987) p2]

3.5 DETAILED DESCRIPTION OF EACH PROGRAM

The teacher's notes indicate that the programs are designed to be simple enough to be operated by an inexperienced 11 year old, and flexible enough to cater for a wide range of classroom situations.

Profile

The program allows certain characteristics of a group of dwellings to be compared with the corresponding characteristics for the region concerned, and nationally. To make worthwhile comparisons, information from 25 to 40 dwellings should be entered. Here a class set of data would be ideal.

The characteristics to be studied are:

- 1 Property type: (detached, semi-detached etc);
- 2 Property age;
- 3 Source of main heating;
- 4 Type of central heating;
- 5 How the domestic hot water is heated;
- 6 Type of insulation in property;
- 7 How many children under 16 live in the household;
- 8 Type of cooker fuel.

Data is collected from the whole group and entered for one characteristic at a time. If necessary, input can be interrupted and intermediate results saved for later reloading from disc. When data input for a characteristic is completed, the data can be edited to make amendments, additions or deletions. After editing, the data can be saved to be analysed at a later date if required. When the data is analysed, the results are displayed in the form of a table. The table can be printed or saved for subsequent printing. The same data can also be displayed in bar chart form.

The program begins by showing an example of how the package displays the data in both tables and bar charts. It can then either look at the statistics included in the program, or be used to enter pupils information and compare these with national or regional statistics. This comparison is done under the headings stated above (1 to 8).

Designed Heat Loss (DHL)

The program contains a model to estimate the major heat losses from the walls, windows, floors, and gaps of each of (or all of) the groups of homes represented as data. The output from this shows where most energy is escaping from the building, and so gives clues as to where to concentrate on seeking improvements. The program is designed so that pupils can subsequently re-run the program with fresh data in order to gauge the effectiveness of these improvements.

The main logical flow is shown in the figure 3.1-1 below:

FIGURE 3.1-1

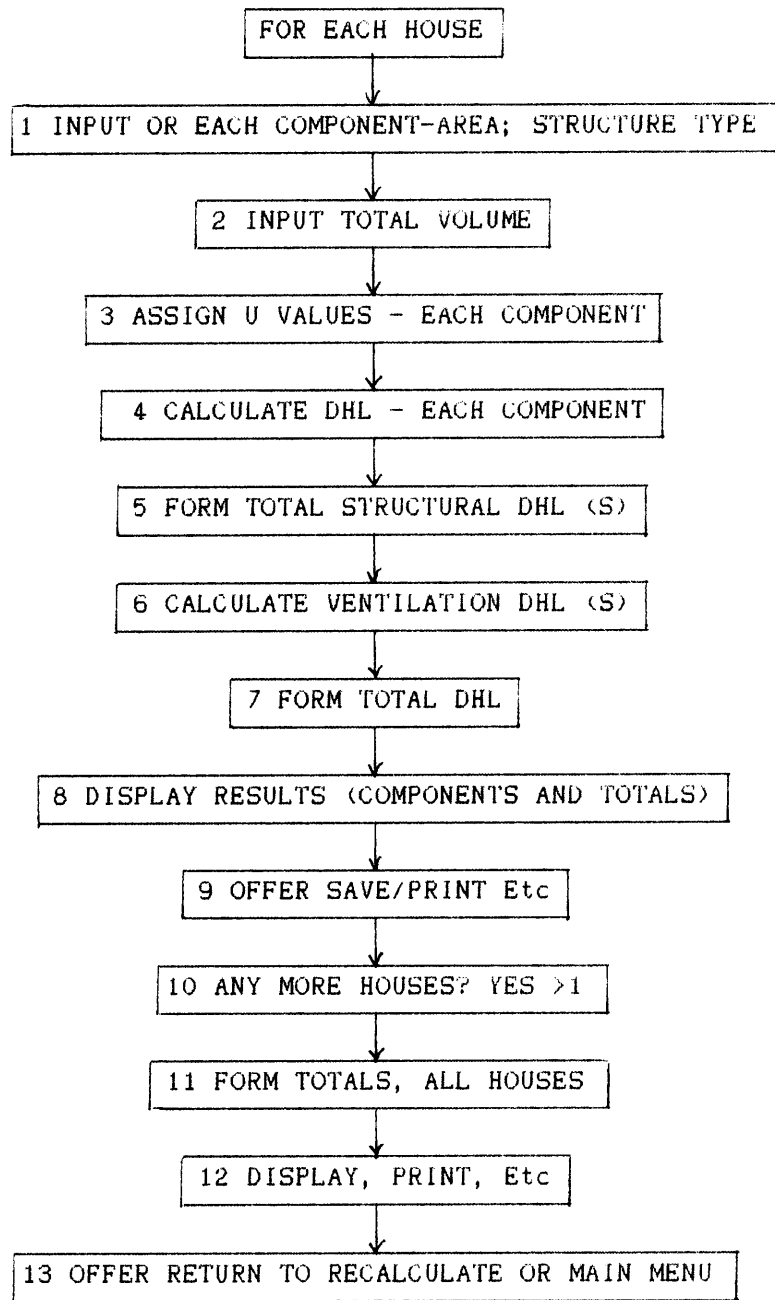

The DHL value is calculated from stored tables of U values (heat loss coefficients). The equation for calculating DHL is as follows:

$$DHL = Q/t = UA(T_2 - T_1)$$

where Q/t is the energy loss per second (watts), A is the area of the fabric of the house under consideration $T_z - T_1$, represent the internal and external temperatures.

DHL is a very useful measure of the effectiveness of thermal insulation of a building and is widely used by building designers and heating engineers.

The documents states that:

"To minimise the data collection requirements a representative number of U values has been selected, hence the DHL will be an approximation. However it will be sensitive enough to reflect the effect of improving roof insulation, for example".

[CEDRIC 2.1 Teachers Notes (1987) p3]

Before starting the program the pupils have to collect information about their home, using the data collection sheets provided. When the data has been entered CEDRIC 2.1 gives the DHL value. This can then be displayed for individual homes, when it will be expressed in **KW** or for the entire group, when it will be in **MW**.

Guestimator

This part of the program works out energy consumption and the cost of heating, lighting and cooking. In the case of the centrally heated house, the consumption is calculated from a series of equations developed by Watson House, the British Gas research station for the domestic sector. The model takes into account the design heat loss of the house, which is determined by

the DHL program, and a factor known as Degree Days, which is a measure of weather variations between regions. A factor is also included that accounts for domestic hot water, which is multiplied by the number of people living in the house.

These equations only apply to centrally heated houses. For other houses that are not centrally heated, a different calculation is made, based upon fuel type used and numbers and type of heaters in the house.

The program asks for information about the number of people living in the home, how big the home is, how it is heated and what other appliances the house has. Guestimator then displays the amount of fuel used - both by type and by cost and will indicate the cost in kilowatt hours equivalent for each fuel type. The program can also show how the fuel is being used, by dividing up energy uses into heating, cooking, lighting, and other uses. All these figures are displayed in the same units, kilowatts hours, and the cost of each heating use is shown, together with the percentage of the total energy use which that figure represents.

Guestimator can not only look at individual results, but can show whether the same house would use more or less energy if it was situated in a different part of the country, both in terms of regional differences and differences in fuel costs.

Gathering Data

In all uses of CEDRIC 2.1 data is needed as input. This is collected by the pupils by filling in a Household Data Form supplied with the program. (This can be seen in Appendix 2). As mentioned in Chapter 2 the Household Data Form caused problems, especially but not only with the younger pupils. The way the data collection sheet was set out was confusing and did not follow the sequence of the program. It also contained different terminology to that found in the program, which confused younger pupils. The data collection sheet was revised as part of the research (see Chapter 6).

3.6 BASIC RESEARCH QUESTIONS FOR THE USE OF CEDRIC 2.1 IN THE CLASSROOM

Four basic questions are considered:

- 1 Can pupils aged 9 to 13 learn about energy by using CEDRIC 2.1?
- 2 What teaching material/strategies can help to make CEDRIC 2.1 part of effective teaching sequence?
- 3 What can be learnt about the appropriateness of CEDRIC 2.1 in this context?
- 4 How important is cognitive level, as opposed to knowledge, in determining the success of the learning tasks within CEDRIC 2.1?

These questions will be elaborated and clarified in Chapter 5.

Chapter 4

LITERATURE REVIEW

4.1 Introduction

This chapter reviews the literature relevant to the study of the learning of energy using computer software. There are four main needs.

The first is to understand how pupils view energy, on the assumption that the knowledge and ideas they hold prior to teaching will shape their general understanding, appreciation, and approach to the learning of ideas. Secondly, a theory of learning is needed as a framework for the research, so as to have a basis for planning a teaching strategy, and describing consequent learning episodes. Thirdly, to consider how useful a piece of software is for a teaching strategy or learning process, it is important to review work on computers in science education, with attention being given to pupils' cognitive skills with respect to those demanded by the software. For this last purpose it will also be necessary to examine research on cognitive demand.

Thus the review will be in four main parts:

- 1 Computers in education;
- 2 Teaching strategies and classroom learning;
- 3 Children's ideas on energy;
- 4 Cognitive development and demand.

4.2 Computers in Education

It is more than a decade since the computer began to be considered as part of the Educational system in schools, bringing with it a considerable quantity of Educational software. As a consequence teachers are faced with many and varied problems relating to this new technology, with respect to their teaching strategies, and to pupils' learning in all areas of the curriculum.

It appears from the literature that there are two main areas in which the computer can contribute to Education: as an aid to learning and instruction in the classroom and as a tool for research on human cognition. In this review emphasis will be on the classroom and the role the computer and its software may play in that setting. It will focus on the interaction of the learner with computer programs.

The application of computing to Education encompasses a range of complex activities. A considerable body of literature has arisen concerning these activities including Self (1985), O'Shea and Self (1987), Solomon C (1986), and Kelly (1984), to name but a few. Recently there has been much focus on the nature and quality of software available in schools. O'Shea and Self (1987) predicted a continuation of advances in hardware technology, but saw trends in software development as a gloomier picture. They suggest that better quality programs are needed but find little evidence of systematic improvement.

"The awful truth is that over the last ten years the availability of mediocre computer-assisted learning material has increased in a steady and boring way - the main effect of the microcomputer revolution being to decrease the average quality of computer software." [O'Shea and Self, (1987), pp260 - 261: cf Self (1985)].

Rutkowsaka J and Crook C (1987), share O'Shea and Self's view as to why so much educational software is unsatisfactory: they indicate that the available programs are too "unintelligent" to support flexible interaction with the learner. The most important attempt to remedy this is to draw on the discipline of Artificial Intelligence (AI). However, it is not the intention to discuss this issue here, but only to indicate that it is accepted as a problem in Educational computing.

Such authors suggest that the difficulties of bringing Computer Based Learning (CBL) into the science classroom, can mainly be attributed to software limitations [Walker (1983)]. Nonetheless, such deficiencies need to be examined, and not overplayed. Computer based methods can now take on a variety of Educational roles, as there are materials, packages and tools to assist a range of practical applications [Hartley (1988)]. What is now required is more data on effective teaching practices and on the process of learning with the computer. Educationists might agree that the computer's presence offers new opportunities to enhance children's lives and to improve the quality, content and delivery of education in part by making more explicit the type of knowledge they are involved in learning or dealing with. However, more empirical data is required to substantiate this view. They might agree that in this way the computer can be an intellectual tool for both learner and teacher. However, improvement depends on taking advantage of the computer's

potential, which requires an understanding of what is possible. It is therefore useful to examine how the computer has been conceived in Educational terms.

A common framework for classifying Educational computing is seeing the computer as Tutor, Tool or Tutee [Nash (1982)]. This framework suggests that understanding the application of computing depends upon seeing all computer use in one of these three modes, with the computer functioning as 'tutor', as a 'tool', or as 'tutee or student'.

The principle behind the tutorial mode is that the purpose of running the program is known in advance, and its structure can therefore be tailored to this end. Its premises are that the objectives of running the program are defined and known in advance, the user being asked questions at each stage for data, and being given instructions, if only of a limited kind. In this way the user is led through a problem step by step. Although this method of computer use has advantages it is limited in what it can achieve. O'Shea and Self (1987) comment that:

"Computer tutors echo the expository teaching versus discovery learning controversy in Educational philosophy. It is straightforward to implement tutors to expound the facts in response to each and every student error but, not unreasonably, students do not take kindly to such programs. The aim as yet unrealised, must be to give only the suggestions, hints and corrections that a skilful human tutor would give."
(pp 171-172)

Within the framework of computer as 'student' or 'tutee', it has been problematic to decide how important it is that a teaching program should determine its actions from an understanding of students needs, through a student model. The 'student model' is

any information which a teaching program has, that is specific to the particular student being taught. The data structures purport to represent a relevant part of the student's knowledge of the subject.

While tutorial systems aim to build up the student's knowledge of certain skills, it is often difficult to make this knowledge explicit enough for the system to be able to generate direct comments about it. Hartley (1985), argues that student models tend to operate on the wrong level: they provide information about the student's attempt to solve specific problems but not directly about his understanding of the general skills involved.

Several of the research questions have been formulated in terms of regarding the computer as a tool. These can be seen in two ways:-

- 1 Is the computer tool learnable?
- 2 To what range of learning activities can the tool, in this case CEDRIC 2.1, be applied?

In some cases, eg LOGO, the first question is difficult to answer, but in the case of CEDRIC is more straightforward. The second question deals with the computational perspective of enriching the traditional curriculum. This in essence can refer to many very general purpose tools. However, CEDRIC is a special purpose tool built around a database system as described in Chapter 3.

Underwood (1984) suggests that databases are seen by many as one of the most effective ways of using a computer in schools, and that such programs use the full potential of machines and give

pupils the opportunity to collect material from their own environment. He further suggests that databases develop skills of hypothesis testing by encouraging children to ask 'good' questions. This type of program can be considered as a way of fostering the acquisition and development of basic linguistic skills, including;

- (a) The ability to code information;
- (b) The ability to organise knowledge within an information structure;
- (c) The ability to express logical procedures for research and analysis.

[Degl'Innocenti and Ferraris (1988)]

Database programs can be said to represent a useful tool for promoting 'research' at an educational level by the provision or creation of manageable data files which allow and encourage pupils to set up a process of observation, classification, and making and testing hypotheses, in this way allowing the formulation of new hypotheses. [Degl'Innocenti and Ferraris (1988)]. It is arguable that in this way the pupil can be enabled to study complex domains with a fresh approach.

This would suggest that the application of information retrieval systems to the learning of complex subjects could prove useful in creating the conditions for using productive learning/teaching strategies. However, if such a system is to improve the skills mentioned above, database programs must include additional teaching materials as well as computer based materials. White (1987) puts this argument well:

"Students ought to be led through a problem-solving process, with explicit demonstrations, practice in identifying information needs and establishing and applying criteria for information sufficiency, relevance and effective organisation."

At the present the difficulty appears to be in establishing criteria by which judgements can be made about the usefulness of such computer based activities. The arguments put forward have depended on the philosophical stand taken, and are used as justifications for educational computing. Most reflect two paradigms of Educational philosophy. The first is concerned with the acquisition of knowledge, and the second with largely unstructured and undirected activity and play. More recently Kelly (1984), has suggested a third, which relates to Experience, with active learning seen as being a matter of process rather than product, in this way promoting development of the child's thought processes. An exponent to this view is Papert (1980).

Papert sees learning as a constructive process where children build their own intellectual structures. He pursues such questions as: "What experience and knowledge lead children to change their theories?"

Papert believes that children learn best when they are encouraged to draw on their own intuition and to put to use what they already know in developing new ideas. He sees the computer as providing a context in which this kind of learning can happen.

Papert's views represent what O'Shea and Self (1987), regard as the 'Revolutionary' faction of educational computing, as opposed to the 'Reformist', who are interested in using the computer in conventional educational contexts. Suppes (1966)

Through these ideas two fundamental questions arise, which are important to the present research. One concerns the 'functional' nature of the computer, and the other is a 'structural' question. In the 'functional' domain the questions arising can be summarised as:-

"What can the computer do to assist learning?"

In the structural domain:-

"Does the advent of the computer give grounds for changing our conceptions of the processes of teaching and learning, and thereby our teaching strategies?"

The second question is fundamental, concerning our most basic assumptions about the nature of knowledge, how it is acquired, and what it is to have knowledge. The emergence of the computer, with its facilities for gathering, processing, storing and transmitting information can pose a challenge to the way Education and teaching are viewed. Teachers may consider their authority as a source of 'worthwhile knowledge' challenged by CBL. Faced with this type of challenge, CBL could be considered as a fundamentally mistaken view of what knowledge is and of what is worthwhile.

4.3 Teaching and Learning

A view of learning that seems to lend itself to computing is that of Bruner (1973). His view that knowledge should be interpreted in terms of the individual's mastery of tools fits well with the current research. Central to his thesis is that:-

- 1 Man is distinctive in his capacity for inventing tools to augment his existing powers;
- 2 Education is the process of acquisition of mastery of those tools.

If as suggested previously the computer and its software is viewed as a 'tool', what makes Bruner's theory especially useful is its integration of the tool function; in this way the computer can be seen as an extension of the user's own powers of reflection. The suggestion here is that the interactive relationship between user and computer is highly significant, when considering the contribution it can make to the teaching/learning process. Functional issues then force teachers to face the formulation of a rationale in order to answer the question:

"What can the computer do to assist learning?"

The interactive element has been explored by Kemmis et al (1977). In their efforts to evaluate early examples of CAL they concluded that:

"The assessment of learner performance by prescribed criteria of achievement in the tradition of the behaviourist model of learning is inadequate. This view of knowledge compatible with a behaviourist position conflates knowledge and information." (p216)

This would indicate that a model of learning is required that acknowledges the importance of the knowledge the individual brings to the learning experience, and that also accepts that such knowledge is not recalling items of information, but it is how knowledge is to be used.

"The successful attainment of knowledge is not merely mastery of propositional knowledge about the subject domain, it is appropriate usage. The teacher will judge that the student has learned when he speaks of the objects in ways which the teacher regards as appropriate." [Kemmis et al (1977) p208]

If the teaching and learning process is to be improved a theoretical framework is required:

- (a) To see how it could shed light on the way pupils think and;
- (b) On possible ways to adjust teaching strategies to complement pupils' thinking.

A recent piece of research which would appear to be of interest to the present research is the concept of 'Middle-Level-Model' of Educational development psychology (MLM) Strauss (1987). The model appears to give a possible framework from which curriculum development/teaching strategies might evolve. The MLM attempts to be in the middle of educational practice and developmental theory. What is useful to the present research is the theoretical basis from which it has evolved.

MLM has been influenced by two traditions, those of Piaget and Vygotsky. The Piagetian psychogenetic model allows for the analysis of concepts, and their development relations, where the role of conflict is as a source of development. On the other hand Vygotsky's approach allows for a relation between children's spontaneous common sense, and formal school based concepts. Both elements would appear fundamentally important when considering the concept of energy, the basic assumption being that children have multiple representations of their knowledge of the world. Solomon (1983). These representations develop in time and possibly have an effect on one another. If so, any form of curriculum development or teaching strategy should take account of these multiple representations. Results of several studies (cf section 4.4) show that children hold representations concerning natural phenomena and how they affect everyday life. These beliefs have been shown to be different from scientific ones and from the ideas often present in the classroom. Driver et al (1984).

It is here that Vygotsky's distinction between spontaneous and scientific (school learned) concepts, could give a possible way of considering these multiple representations. He regards spontaneous concepts as being unconscious, non-reflective, originating from childrens' direct experience of the world. They are non-systematic, and learnt through everyday experiences in order for them to become part of the child's conceptions. It is widely accepted that it is necessary for teachers to be conscious of these ideas when pupils come to science lessons.

Recently much emphasis has been given to a 'constructivist' form of teaching. For this purpose, these ideas could possibly be grouped together into two broad headings or domains as suggested by Solomon (1983). She regards the two domains as 'life world' Concepts derived through language, peer groups, and media, which are often context bound and used inconsistently by pupils. On the other hand 'Scientific knowledge' is decontextualised and consistent, but is for most children confined to the science classroom. Solomon (1978) drawing on work from Schutz and Luckmann (1973), presents a theory of the social construction of meaning in which she argues that "Objects of commonsense", exist through social communication, whereby ideas are exchanged and explored. Whether a pupil can affirm or even share these ideas with others in a classroom situation has a part to play in shaping the construction of the knowledge gained by pupils.

"We take it for granted that those who are close to us see the world the way we do, but through social exchanges we seek always to have this reconfirmed. This continued reaffirmation of social notions make them very durable and resistant to change."
[Solomon 1987, p67]

Driver (1989) argues that learners need to be given access to the 'knowledge systems of science'. Here she means that pupils need not only the physical experiences, but also the concepts and models of conventional science, to be given, in order to construct them for themselves and appreciate their domains of applicability.

What consequence has this perspective for teaching strategies? Various groups of researchers have attempted to identify features of science teaching that might have implications for classroom practice. Examples are taken from two action research projects:

- 1 Childrens Learning in Science Project, based at the University of Leeds (Driver and Oldham (1986) (CLISP);
- 2 Student's Intuitions and Scientific Instruction. (SI) Project [Kuhn and Aquirre (1987)], based at University of British Columbia and directed by Gaalen Erickson.

Both projects worked collaboratively with teachers and took a constructivist approach to classroom work. The position taken especially by Driver is that:

"Learning in science is characterised neither by learning 'content' nor by learning 'process' but by a dynamic interaction where-by pupils continually and progressively construct and reconstruct their understanding of the world." [Driver (1989) p76]

This suggests that learning requires giving pupils opportunities to make explicit their understanding and then to consider alternatives. In this way it is assumed that pupils are actively involved in the process of theory change, and will hopefully not accept empirical evidence as given. The research from the SI project indicates that it is:

"Crucial to listen to what students have to say, and that the teacher must make this listening part of reflecting back on what the pupil said or did."
[Aquirre and Kuhn (1987)]

It is claimed that this 'constructivist' approach to teaching and learning is based on current perspectives of cognition, that it takes account of the social processes of knowledge construction, and that it reflects contemporary views of the nature of science itself. Edward and Mercer (1987) have explored, and given an analysis of teacher-pupil interaction in activity orientated classrooms, and come to the conclusion that:-

" We shall not be using any critique of progressive education to argue for a return to traditional didactic methods. The progressive movement was right to argue for the importance of children's active engagement in their own education. What we shall advocate is a third step, towards a cultural-communicative model of education The traditional ideology was all about teaching, and the progressive ideology is all about learning. What is needed is a new synthesis, in which education is seen as the development of joint understanding." (p36)

It has long been quoted that:-

"The most important single factor influencing learning is what the pupil already knows. Ascertain this and teach him accordingly." Ausubel (1968)

It would seem useful to the discussion to examine some examples of what is meant here before looking in depth at the literature concerning pupils' conceptions of energy.

A good example of the type of concept being discussed is that of Heat and Temperature. Children directly experience objects at differing temperatures, through playing, bath time, and watching water boil, etc. In such situations they might add hot or cold water hence making things 'hotter' or 'colder'. This type of

spontaneous knowledge of temperature is learnt unsystematically. Similarly some of children's notions of energy are constructed through media representations for example that certain foods give energy and that certain fuels are more 'energy efficient' than others. They are often being told to eat because they need 'energy', or to switch the light out or shut the door in order not to waste, or to save energy. This could give insight as to why pupils have difficulty with conservation of energy and the definition of energy.

In contrast however, Vygotsky sees school-learned concepts as conscious, reflective, originating in the classroom (or in an informal educational setting), and systematic. Examples 1 to 4 below, taken from heat, temperature and energy, indicate what is implied by school based concepts.

- 1 Thermal equilibrium, when two objects at different temperatures eventually reach the same temperature.
- 2 Quantification of temperature in degrees.
- 3 Energy is neither created or destroyed.
- 4 Quantification of energy measured in Joules.

It is difficult to envisage how children could construct these concepts from everyday experience without having some form of instruction. Vygotsky views spontaneous and school-learned concepts as two sides of a single process, concept development, but not as being identical in nature having different origins (personal experience and classroom experience). They also develop in different ways, spontaneous concepts being 'data-driven', processed bottom upwards. This would indicate a dynamic development between two kinds of concepts. This dynamic view

would fit with Kelly's (1956) and Piaget's emphasis on cognitive interaction with the world, characterised by active assimilation.

How then can this be of use for the teaching and learning of energy? Vygotsky suggests that:

"To devise successful methods of instructing the school child in systematic knowledge, it is necessary to understand the development of scientific concepts in the child's mind." (p82)

He poses two questions of particular relevance to guiding the present research.

- 1 "What happens in the mind of the child to the scientific concepts he is taught at school?"
- 2 "What is the relationship between the assimilation of information and the internal development of a scientific concept in the child's consciousness?" [Vygotsky (1987) p82]

The first of these two questions can be considered in relation to the view of 'meaningful learning' [Ausubel (1968)]. That is, what sense do pupils make of scientific concepts as taught in schools? According to Ausubel meaningful learning occurs only when new material is linked by the learner to relevant ideas and conceptual schemes he possesses in his existing cognitive structures. Tomlinson (1981) suggests that the process of learning must begin with some sort of acquisition or grasp of what is involved.

This leads to the second question which concerns much of the present work. Does the learning of scientific concepts, such as energy, as taught within a teaching strategy alter the pupils' everyday, commonsense, spontaneous understanding of the same concept? However, an equally important question to be asked is:

"To what extent do pupils' commonsense, spontaneous understanding influence what is learnt from scientific concepts as taught in schools."

To be able to construct a series of teaching strategies that might in some way attempt to focus on these issues, requires a framework deriving from a theory of learning that can highlight them. Although there has been much research on children's thinking and learning, there is still little that explains how pupils learn large bodies of complex material over a period of time. One such attempt was made by Norman (1978). The theory, and the way it could be used, in the present research, to identify the intellectual demands teachers make on children, is worthy of discussion. Norman is interested in the way learning takes place in complex situations. He defines this by referring to complex topics as:

"A rich set of conceptual structures that require learning periods measured in weeks or even years."
[Norman (1978) p39]

Central to his argument is the notion of memory representations. He views all learning as organised into schemes, with new learning experiences having to interact with what the learner already knows. In this way meaningful learning can occur. How can this new knowledge be acquired? He suggested that there are three ways in which this acquisition can take place. First, that the new knowledge can be added to the framework provided by existing knowledge modules: this mode of learning he calls ACCRETION. Second, new knowledge modules can be formed by reconceptualising knowledge about a topic, this he calls RECONSTRUCTURING. Third, existing knowledge modules can be made more effective by specializing the information contained within

them for the particular task required of them, this is called TUNING.

Accretion is necessary to provide a database upon which appropriate knowledge modules can later form. In the learning process accretion seems to be needed to fill out the knowledge.

Reconstructing is often characterised by insight into the topic. If accretion is knowledge acquisition, restructuring is knowledge understanding. The important notion here is that there need be no formal addition of knowledge by the pupil during restructuring. In terms of a teaching situation this can be of interest. The teacher need only ask questions, carefully avoiding the presentation of any new information. However, by skilful questioning it would seem possible to lead the pupils into recognising their own deficiencies in the structuring of their existing knowledge. Norman indicates that for restructuring to take place, good teaching must occur.

Tuning requires the repeated use of knowledge, and seems best accomplished by practice at the task or using the concepts of the topic matter.

What is useful to the present study is that Norman suggests that all three modes of learning are probably always present, however:

" Because learning a complex topic has neither a definite starting point nor a definite ending point, the start always builds upon previously acquired material (thereby making unclear where the start really occurs)." [Norman (1978) p42]

Further he suggests that one could obtain some reasonable information by tests at different times in the learning of new material

"In particular, the modes of learning differ in the kind of instructional procedures that are most relevant, the test of knowledge that seems most appropriate, the ability to transfer the newly acquired knowledge to other, related topics, and the susceptibility to interference from the simultaneous learning of related topics." p42

In an extensive research Bennet et al (1984) attempted to use Norman's theory to examine the 'Quality of Pupil's Learning Experience'. The study considered the teaching process in the classroom environment, of 6 to 7 year old children. It brought to light a number of issues that could be regarded as important for teachers, such as the nature of classroom tasks, and their appropriateness and match to children's abilities and cognitive levels. The study appeared to show the possibility of this type of research.

Central questions here are:

"What does it mean to have learnt something?"

and

"Is learning related to understanding?"

These are however fundamental in relation to the argument put forward earlier regarding Vygotsky and the nature of concepts. Norman categorises the above two questions into two sections, which can help when thinking of teaching strategies. These are:

- 1 The study of learning which relates to the acquisition of information;
- 2 The study of performance which emphasises how the information is used.

Performance and understanding are different things. It isn't enough to know something; the knowledge must be available at the proper time, and it must be represented in a form appropriate to the specific needs of the moment. This poses the question:

"What implications do these theories have for the teaching and learning of energy with computer software?"

Bruner (1978) offers a view that the computer can be seen as a tool for learning, allowing the user to consider the computer as an extension of his own powers of reflection. This is important when considering Norman's (1978) theory of learning, with respect to the acquisition of information and how that information is used. If we accept Ausubel's (1968) statement of meaningful learning as a prerequisite for teaching, then the computer as a tool allows the categories of Norman's theory to be implemented in the development of teaching/learning tasks in terms of new information given, how it is to be used and to see if it is understood by the pupil.

If such tasks are to be developed, a theoretical framework relating to pupil's prior conceptions and developmental stages is needed. Strauss' (1988) MLM theory allows for the analysis of both as it originates from Piaget and Vygotsky. Vygotsky's approach is important to the research as it allows for the relations between Children's spontaneous common sense and formal school based concepts to be considered. The Piagetian approach allows for the analysis of concepts and their developmental relations. In this way teaching strategies can consider the nature of the pupils' preconceptions and their cognitive level.

In conclusion the way these ideas are used in the research is that it takes Ausubel's statement as a starting point for thinking about teaching strategies, and that Bruner allows for the computer to be considered as a tool for learning. Norman gives a theoretical structure for the planning of teaching tasks, Vygotsky allows for the consideration of preconceptions, and Piaget allows for the assessing of the cognitive demands of a task in relation to the development of a child. The outcome of which can be seen in Chapters 6, 7 and 8.

4.4 Children's Ideas on Energy

Many of the recent publications on children's ideas of energy have attempted to explain the underlying causes and origins of these conceptions. The literature can be divided into two broad categories, each approach focusing on certain elements, such as:

- 1 General research that attempts to illuminate common aspects of a range of children's concepts such as Osborne, Bell and Gilbert (1983);
- 2 Research relating to children's understanding of specific concepts such as energy, eg Brooks, Driver, Solomon J, Watts M (1983).

The literature in the first category has given the area various labels such as 'Alternative Frameworks', and 'Misconceptions'. Here I wish to discuss the specific conceptions found within the second category.

One of the major descriptions of children's conceptions of energy is given by M Watts (1983), who gives seven categorisations of energy. His classification can be regarded as a set of metaphors to help understand children's ideas and explanations of energy associated with events, in this way giving possible indications

as to how a teacher might actively help the pupil learn about energy. I will use these as a means of discussing the literature.

1 "Human Centred" (Anthropomorphic)

Watts identified this element when students were asked a series of questions relating to energy in certain situations. He found that many of the responses indicated that pupils regarded energy as associated with human beings or with objects to which they attributed human characteristics. Black and Solomon (1983), indicated that this type of association occurs with the younger pupils who have received little or no instruction about energy. Pupils aged 11 to 13 were given written tests, questions in which energy was associated with words such as growing, food, and exercise, but found that the emphasis decreased with age. By 13 a third of the pupils had ideas concerning the notion of energy being quantifiable and universal. Other studies such as Brooks (1986), and Stead (1980) refer to the everyday meaning of energy being associated with 'Energeticness'. Watts distinguishes the living associations of energy into two: anthropocentric and anthropomorphic. The notion of 'Energetics' as reported by Stead (1980) falls into the latter category, as pupils associate the idea that living things need energy to live and be active.

2 "Source of Force" (Clement 1978)

Watts identifies this as the 'Depository' framework. Here some objects have energy and are recharged, while others 'need' energy and expend what they have got. The

notion of force being linked to energy was studied by Watts and Gilbert (1983), when interviewing 15 to 17 year old pupils. The results suggested that for some pupils the words 'force' and 'energy' were synonymous. Duit (1981) also found a similar association in Germany, when asking pupils to fill in a questionnaire before and after a unit of instruction on work, energy, power and force. He found that 20% included force as an association prior to teaching, with very little difference after. In a later study Brooks and Driver (1984) analysed responses from pupils aged between 14 and 15 about energy. They found that in response to a question about a ballbearing being released in a U-shaped track, very few pupils used the word 'energy', but focused on the amount of force the ballbearing had at different parts of the track. The way the word 'force' was used suggested that their concept was one of Kinetic Energy, not of force in the scientific sense.

Watts describes his 'depository' model as energy being a causal agent, a source of activity based or stored in certain objects. Pupils see energy both as objects needing energy and as others having and expending it.

3 "Energy as an Ingredient"

Energy is considered as a dormant ingredient within objects, which needs a trigger to release it. This suggests that objects such as food and fuels have no stored energy themselves but can give energy if something is done to them, eg they are eaten or burnt. Watts suggests that energy is not

seen as a causal agent, but as a dormant one that needs to be triggered.

4 "Energy as an Obvious Activity"

Here energy is identified with an outward overt display of activity, labelled by Watts as an 'Activity Framework'. This particular approach was reported by Gilbert and Pope (1982), using Watts' frameworks in a study of children aged 10 to 12 years.

Many of the responses suggested a framework where energy was associated with 'ostensive activity'. For some pupils energy is strongly associated with observable movement, so that non-moving objects are not considered as having energy.

5 "Energy as Functional"

Watts also listed 'functional energy', as a kind of fuel, which is mainly associated with those processes that make things work, particularly technical appliances. He concluded that there was a connection between energy and processes which make life more comfortable. Thus for some pupils things having energy included cars, aircraft, etc, but falling books, clouds, etc which do not work for us are not considered as having energy. Solomon (1983) describes 'provinces of meaning' of the word energy, one of which is the idea of energy as a world wide resource in short supply. Stead (1980) also describes the general fuel idea and suggests that students' responses often indicate 'energy crisis' and 'conservation of energy', which in reality means fuel crisis and fuel conservation. This tends to lend itself to the idea

that possibly fuel is being considered as energy itself. Duit (1981) found 10% of his students mentioned the 'energy crisis' before teaching and one third mentioned power plants, when discussing the 'functional' aspect of energy.

6 "Energy as Product"

Energy is considered a by-product of a situation being generated, active and disappearing (product framework). In their study Gilbert and Pope found few instances of this framework in comparison to the 'depository'.

7 "Energy as a Flow-transfer Model"

Energy is seen as a type of fluid or substance, able to be transported or carried. This view was particularly evident in students' comments on electrical energy. Duit's (1981) study suggests that students frequently associated the word energy with current. However, he does also point out that this could mean energy being viewed as a fluid and also suggests a fluid motion of energy. For example energy can sometimes be seen as a substance flowing through circuits, transported by carriers.

4.5 COGNITIVE DEVELOPMENT

A recurring question in the literature appears to be:

"Can schools work in harmony with development?"

Studies regarding the development of the ability to think, offer important insight into how schools can be more effective in this area. Some of the major questions have focused on the matching of cognitive level of pupils to the types of curriculum material

offered to them. This section will try to illuminate these issues, by expanding on the theoretical framework on which they are based.

The work of Piaget and others has had a considerable impact on curricular issues such as:

"When should selected topics or concepts be introduced into a student's education?"

From a Piagetian point of view, cognitive development is seen as increasing the structural complexity of cognitive processes: it involves a description of human thinking under certain conditions. There are three central pedagogic implications deriving from the Piagetian theory:-

- 1 Development occurs through an invariant hierarchy of stages, in which the successful negotiation of one stage is a prerequisite for optimal development of the next.
- 2 Each stage has an underlying unity of operations, which applies to all intellectual skills exhibited within that stage.
- 3 The key process of development is identified as equilibration which describes the process of reciprocal interactions between environment 'inputs' (experience) and growing cognitive structures.

This growth is partially due to maturation, but primarily arises out of active interchanges and variations in the intellectual content of environment encounters.

Brown and Desforges (1977), although arguing against 'stages', refer to the way that:

"Practices of assessing children's performances, sequencing curriculum material and structuring learning environments to facilitate progress are justified, not directly from Piagetian observations, but from the abstract notion of stages and development processes which Piaget takes as explanations of his observations" (p7).

(Brown and Desforges go on to argue that they should not be, since in their view Piaget is wrong).

This would indicate that educational implications arise from the underlying principles of Piaget's epistemology, which in turn makes the relationship between theory and practice an important one to understand. The idea of 'stages' involves a coherent integration of operations into a theme, or a series of themes, which underlie certain categories of behaviour at a particular point in time. Against this Brown and Desforges (1977) argue:

"A considerable number of studies have cast doubt upon the integrity of stages, some referring to the surprisingly low correlations between behaviours at a given time, others to the absence of expected operations " [see also Pascual-Leone, (1970)].

However, there has been much positive work in curriculum development based on Piaget's theory, notably that of Shayer (1978). The problem Shayer addresses is that of arranging instructional materials in an optimal learning order: ie the problem of matching tasks to the learner's attainments and abilities. In attempting to optimise the sequence of teaching/learning experiences for pupils Shayer uses Piaget's theory of cognitive development. He analyses the conceptual demands of several science schemes; [Shayer (1972, 1974)], notably the Nuffield Science courses.

Shayer developed his work by establishing the utility of some part of Piaget's theory. He focuses on the 'developmental construct' which asserts that:

"People's minds have reality - processing mechanisms whose operations on reality can be described."
[Shayer 1979 p265]

The claim implies that performance on certain Piagetian tasks can be used to characterise a person's developmental level. Other tasks (eg curriculum tasks) could be analysed to ascertain their intellectual demands in similar terms. These latter tasks can then be matched to the developmental level of the learner. Such a matching model was developed by Shayer and Adey (1978) and put forward as a curriculum taxonomy, which rested on three basic assumptions:

- 1 That identification of Piagetian stages reached by a person's reasoning is possible by means of a limited test, and that this is useful as an indicator of that person's reasoning in relation to a wide diversity of scientific content;
- 2 That curriculum tasks can be analysed for their level of cognitive demand, that is for stage-related skills required for their understanding;
- 3 That meaningful learning will only occur when the cognitive skills demanded by the task are available to the student.

The first assumption has been heavily criticised, as it is concerned with the unitary nature of the concept of stages. [Brown Desforges (1977), (1979), and Driver (1982) p126]. However, Shayer provides empirical evidence for the unitary nature of the formal operational stage of thinking (1979) p271 and Lawson [Lawson and Snitgen (1982) p238] reports similar findings.

The second assumption that content can be analysed for level of cognitive demand has been criticised on the grounds that the problems associated with assessing pupil's level of cognition also apply to the analysis of curriculum material [Driver (1978) p59, Driver (1979) p80]. Klausmeier and Sipple [1982 pp161-180] would support Driver, from evidence collected from a longitudinal study relating to the concrete period. However the techniques developed by Shayer (1970), (1972), (1978) and Ingle and Shayer (1971) have proved successful on several science curricula, notably that of Nuffield Chemistry and Nuffield Physics.

The third assumption is the 'readiness' issue as discussed by Rowell [1984 p5]. Shayer et al [1981 p166], argue against this notion using the position of optimal matching, ie that the intellectual steps of a science course are matched to the student. Rowell and Dawson [1980 p694] counter argue, suggesting that students who do not seem to possess the appropriate formal skills could be taught 'concrete equivalent skills' to solve the problem. Lawson [1982 p82] suggests that:

"What we seek is the identification of a basic unified set of mental operations that can be taught and will improve achievement in a general sense."

Thus the work of Rowell and Dawson, Lawson, and Shayer is all based on Piagetian lines, with each making assumptions and each having their problems. Shayer's optimal matching procedure is one interpretation of a Piagetian position, and if it is to be used in a positive way, as in the present research, the assumptions on which it is based need to be understood. It can be argued that Shayer has provided a technique for curriculum analysis which is theory-based and allows teaching/learning

strategies to be considered in a way that might help instructional problems.

From Piaget it is possible to think in terms of developing structures of thought and to consider ways in which children's cognitive structures influence what they know as well as what they will choose to learn. However, it is accepted here that Piaget's developmental theory as interpreted by Shayer cannot take into account a pupil's beliefs and the preconceptions with which he approaches a task, together with the effect these have on his thinking. Lovell and Shayer (1977) suggests that:

"When preconceptions are at variance with experimental findings, the adolescent is likely, at first, to put his faith in the former and not in logic, although he may well have the requisite logical thinking skills at his disposal. Indeed, it is not until he becomes experienced in seeing connections between phenomena that he is likely to reject his preconceptions and have faith in scientific methods." (p107)

Driver (1973) clearly shows that the language and forms of the scientific methods may be quite familiar to the students before they are used with confidence as a natural preference.

There is considerable evidence to support the notion that there is a real difference between conceptual systems of young children and those of older pupils and adults. Although this is a basic characteristic of Piaget's work, it has also been pin-pointed by Vygotsky (1962) and Bruner (1966). However, Novak (1977) believes that children acquire a hierarchically organised framework for specific concepts and do not develop general operations as Piaget's theory claims. Novak prefers Ausubel's theory of meaningful learning as a guide to teaching practice. Shayer's response to this is that:

"To start from what the learner already knows leaves unanswered the questions about how one can describe or measure what the learner knows, and more importantly, what processing skills the learner has available to cope with new material." [1978 p5]

The position taken for the present research is that it is important to consider what the pupil already knows, but that one must also take account of the appropriate skills available to that pupil in order to assess the potential of the tasks to be set.

4.6 OVERVIEW

The question to be posed here is:

"What can be learned, for the purpose of the present study, about how children's conceptions of energy, within a learning theory can affect teaching/learning strategies that incorporate computer software?"

The notion that all pupils have prior ideas or conceptions or multiple representations of their worlds prior to instruction, and that these ideas are difficult to change is accepted. One way of attempting to understand these conceptions has been through Vygotsky's distinction of spontaneous and school-learned knowledge. An overview of the literature appears to indicate that children have characteristic ways of constructing their spontaneous commonsense concepts, and that these mental constructions do not necessarily mesh with school-learned knowledge about the same concepts. Establishing these problem areas has led to various approaches to teaching/learning strategies.

A dominant approach has been that of the constructivist. This explains conceptual change as the product of interaction between

existing conceptions and new experience. Theories of learning, such as Norman's, where concept change is said to be difficult because concept learning is not simply the accretion of new ideas, but the reconstruction of meaning, have been interpreted and adopted by some as a model for constructivist instruction, [Driver 1989, CLISP]. In the context of the present research it would appear evident that an adequate description of the structure of pupil's prior conceptions of energy would be required if appropriate learning tasks and teaching strategies are to be examined in a way that might address the changes learners need to make in their conceptual schemes. However, a constructivist theory of learning is not the same as, nor necessarily implies a constructivist model of instruction. Norman's Theory of Complex Learning would appear to give a possible framework, for teaching, and for examining the issues involved in planning teaching/learning strategies.

Strauss's (1989) Middle Level Theory was examined to see how a theoretical framework based on Piaget and Vygotsky could offer possible ways of discussing the relationship of pupils' conceptions with instruction. It proposes that there are:

"Universal inevitable changes in children's thinking over a period of time, but also important changes come about through the conscious efforts of those who attempt to transmit knowledge."

If the teacher is to transmit knowledge with the aid of the computer as in the present research, one must ask the question:

"How do we view the computer within a learning theory?"

Bruner's view that knowledge interpreted in terms of the individual's mastery of tools offers this middle area the possibility of considering the computer and its software as a 'tool', allowing the pupil to reflect on his own ideas, but also allowing for interaction between teacher, pupil and computer, in this way encompassing what Vygotsky calls the 'Zone of Proximal Development'. He intended the notion of 'Zone of Proximal Development' to capture the fact that:

"Learning should be matched in some manner with the child's developmental level." [Vygotsky, 1978, p85.]

If this interaction is to be successful a critical question is whether the teacher can make the right assumptions about where pupils are in their understanding of energy at the start of the topic, in order to minimise the amount of mismatch. The suggestion appears to be centred on the conceptual demands placed on pupils. The argument put forward is that if this mismatch could be ascertained then it would be possible to improve the quality of the pupils' learning experience. Shayer's Curriculum Taxonomy provides a way of considering such demands, both for the pupil and the curriculum material being used.

CHAPTER 5 RESEARCH QUESTIONS

5.1 INTRODUCTION

This chapter aims to consider the research questions raised in Chapter 3 and the assumptions made within the research itself. Each of the questions will be looked at and discussed.

5.2 QUESTIONS RAISED

1 CAN PUPILS OF AGES 9 TO 13 YEARS LEARN ABOUT ENERGY BY USING CEDRIC 2.1?

In order to address this question, it is necessary to analyse the nature and the structure of the tasks the program requires of the pupils. This analysis has three components:

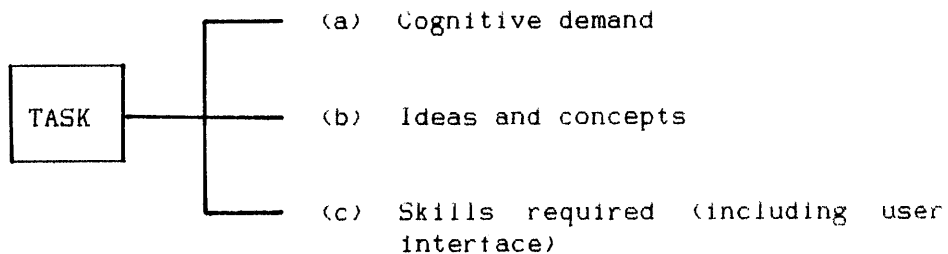

(a) COGNITIVE DEMANDS

The cognitive demands of the software are analysed using the Shayer Taxonomy, (section 5.3) as a means of approximating the level of understanding required to attempt the tasks in question; incorporating this with the data obtained from the teaching will help to provide evidence about whether the analytical use of the taxonomy has appropriately identified the levels of cognitive demand of the tasks. In order to achieve this aim, a sequence of tasks are chosen from CEDRIC and compared with the various levels of development as they appear in the taxonomy. This gives an indication as to the type of

reasoning required, and the cognitive demand in terms of cognitive level required by the tasks.

The pupils are asked to complete two Science Reasoning Tasks in order to obtain an idea of their cognitive levels. The first Science Reasoning Task used was Spatial Relationships; a drawing task, involving childrens' perceptions of verticals, horizontals, and perspective. This gives indications of cognitive levels between pre-operational and late concrete operational. The second task involves Volume and Heaviness. This task considers the conservation of substance, weight, volume and proportionality as density, and explores pre-operational thinking to early formal operational thinking.

The published research indicating expected levels at different ages is used to anticipate ages for which tasks and teaching strategies would be appropriate, and cases where they may need modification to reduce their level of demand.

(b) **IDEAS AND CONCEPTS REQUIRED**

The ideas about and concepts of energy implied by or pre-supposed by the software tasks are examined to see how they match with those of the pupils. To do this it is necessary both to analyse the software from this point of view, and to investigate pupils' ideas on energy.

The software is examined in terms of which ideas about energy are:

- (a) required?
- (b) assumed or taken for granted?
- (c) taught?

It follows that evidence is needed of the nature of the preconceived ideas that pupils hold. This data is collected by a specially developed questionnaire, a detailed description of which is given in Chapter 6, which characterises relationships between pupils' ideas about energy loss, transfer, creation, need etc. Qualitative data is also collected from pupils' work during the teaching process.

(c) **SKILLS REQUIRED**

The skills required to perform the tasks also need to be established. The relevant skills fall into four main groups.

Mathematical Skills

Can the pupils manage problems using percentages? Do they have the computational skills or must these be taught prior to the use of the software?

Practical Skills

Do the pupils have the ability to measure and record their findings accurately enough to be able to perform the tasks adequately?

(1) Data Collection Skills

Do the pupils know how and where to find the information needed to complete the task and if so, do they know what to do with the data they have collected?

(2) User Interface

Can the pupils control and manage the program itself? In particular:

- (a) How much help is required to enable successful use?
- (b) Can the pupils follow the instructions, and therefore insert data in the correct sequence to obtain results?

2 WHAT TEACHING MATERIALS/STRATEGIES CAN HELP MAKE CEDRIC 2.1 PART OF AN EFFECTIVE TEACHING SEQUENCE?

Designing a teaching scheme to incorporate CEDRIC 2.1 is attempted in the research. From the pilot work it was evident that if such a task was to be undertaken it was essential to consider how and where the software was to be used. This initial attempt gave indications as to how it could be incorporated into an overall teaching strategy, and the type of material needing to be developed in order for the pupils to achieve success within given tasks. The relevant questions are:

- (1) How successful were the materials/strategies used?
- (2) What evidence is there that the pupils have learned?
- (3) How can these strategies be implemented in the classroom with respect to the curriculum?

3 WHAT CAN BE LEARNED MORE GENERALLY ABOUT THE "APPROPRIATENESS" OF CEDRIC 2.1?

The research as described above can only directly show that CEDRIC 2.1 can be used effectively in one particular way in a small number of different contexts. It will be important in addition to at least propose, speculatively but on the basis of the evidence gathered, more general lessons that might be drawn about how it might fit into other teaching schemes with other kinds of pupils. Here the evidence about cognitive demand, and about pupils' ideas on energy, will be relevant in helping to identify critical issues relating to the use of the software.

In order to be able to say anything at this level it will be necessary to have looked at:

- 1 What the pupils have learnt;
- 2 What major difficulties they have faced;
- 3 What improvements might usefully be made to the software and/or the teaching strategies.

4 HOW IMPORTANT IS COGNITIVE LEVEL, AS OPPOSED TO KNOWLEDGE, IN DETERMINING THE SUCCESS OF LEARNING TASKS WITH CEDRIC 2.1?

In addition to the empirical work on incorporating CEDRIC 2.1 into a teaching scheme, this further question is addressed through considering the relation of cognitive level and prior knowledge, to the performance of specific tasks required by the software. The research will have already looked at the cognitive demands of a sequence of tasks, and have examined the pupils prior knowledge on energy. This will be followed up by a more intensive study of one task, in this case obtaining evidence of pupils' cognitive levels via

Shayer and Adey tasks, together with tests of the knowledge of energy required by the task.

5.3 ASSUMPTIONS MADE IN RESEARCH FOR THE USE OF CEDRIC 2.1

The aim of the research was to see how and in what way the use of CEDRIC 2.1 can help in the teaching and learning of energy, and to test the value of some of the support material and teaching approaches developed for it.

The research makes some assumptions about what factors are relevant to this learning. Included in these are pupils' cognitive levels of development, and their prior knowledge and ideas about energy. A theory of learning deriving from Norman (1978), will be used as a framework for designing teaching sequences.

The work addresses questions about two areas: the knowledge and skills pupils need in order to learn from this software, and the teaching material/strategies that might be required to make the software part of an effective teaching scheme.

In considering pupils' knowledge and skills, attention will be given to the importance of cognitive level, as opposed to knowledge, in determining the success of the software and teaching material.

For the purpose of taking account of the cognitive demand of the software and the cognitive levels of pupils, Shayer and Adey's (1981) interpretation of Piaget's work will be used. The Shayer Taxonomy is designed to aid in the matching of

curriculum content in science to the abilities of pupils, based on group Science Reasoning Tasks, for assessing children's ability to use concrete and formal operational reasoning strategies. It will be assumed that the taxonomy can be relied on for the investigation.

Secondly, it is assumed that the knowledge and ideas pupils have on energy prior to any teaching will be of great importance to their general understanding, appreciation and approach in the learning of energy.

Thirdly, given that a theory of learning is required as a framework for the research, Norman's Theory of Complex Learning (1978) will be taken as giving a useful descriptive structural plan, in terms of teaching strategies and consequent learning episodes.

The last, but equally important notion, is the assumption that the energy related software used within the research is worth studying when integrated into a well constructed teaching plan on energy rather than taught in isolation.

CHAPTER: 6 WORK CARRIED OUT AND DATA COLLECTED

6.1 OVERVIEW OF THE RESEARCH

This section aims to give a general view of the work conducted in four chosen schools. It will give an outline of the work carried out and indicate variations in tasks completed by the pupils in each school. It will also describe the types of data collected.

The choice of schools was made so as to incorporate children of differing ability and age, in order to obtain a broad picture of children's learning about energy, and of the use of the software in schools.

Four schools were used, two Primary and two Secondary. The age range covered was 9 to 14 years. The school will be referred to as Primary Schools 1 and 2, (P1, P2) and Secondary Schools 1 and 2 (S1, S2).

For the data to have something common to all schools a pre-devised energy questionnaire was given to each pupil taking part, in order to try to find their ideas about, and knowledge of energy, prior to any teaching or use of the software. (The questionnaire can be seen in Appendix 3). Its formulation is discussed in detail in section (6.2) of this chapter. Due to the age range covered, the questionnaire was kept as simple as possible, yet giving a maximum return in data collection.

It was hoped that the data collected in this way would give some indication of the similarities and some of the differences between the age ranges. The pupils in P1 and P2 were given

Science Reasoning Tasks to establish their cognitive levels, so that a comparison could be made between their levels and those demanded by the software. Unfortunately due to constraining circumstances in the Secondary school, the Science Reasoning Tasks were not able to be administered there.

In each school, pupils undertook an energy project, using CEDRIC 2.1. However, the type of project work carried out by the pupils varied in each school. This was due to the fact that the research was carried out at the end of the summer term, when many of the pupils were engaged in various activities that removed them from their classroom and their lessons. Common to all schools was that I personally taught most of the work on energy, including supervising all the computer work by the pupils.

The basic aim of the work was to see how and in what way CEDRIC 2.1 could be used in schools to maximum effect. Included in this was to see how CEDRIC 2.1 could be used or adapted for pupils of differing ages and abilities.

The two Primary schools came from urban areas. Primary School 1 was a junior school of approximately 200 to 300 pupils from a varied catchment area, including both middle and working class homes. The class used was of mixed ability. Primary School 2 was a larger school of approximately 300 to 400 pupils. It had a mainly middle class catchment area, with mixed ability classes. Both schools used a strong thematic approach, especially to the teaching of "science". However Primary School 1 was far more formal in its teaching approach, with pupils guided by the teacher throughout the week. Primary School 2 used a matrix

system of learning. Each child had its own matrix and had to complete that work by the end of the week. Each completed piece of work was marked or inspected by the teacher. Thus these two schools represent substantial differences in teaching contexts.

The two Secondary schools also came from urban areas, but were very different in nature, especially with regard to ability. Secondary School 1 was a very selective girls' school with high ability pupils, and Secondary School 2 had predominantly average to below average ability pupils, with a high proportion of pupils being boarders.

The nature of the work to be carried out was discussed beforehand with each school. It was aimed to complete broadly similar work at each school, whilst complying with the needs of the teachers involved, and their objectives for introducing this particular topic to their classes.

In Primary School 1, a project basis was adopted in which the computer software could be included quite easily into the teacher's pre-planned teaching scheme, which was "Energy and Man". This teacher wanted the pupils to obtain an overall view of energy, rather than a purely scientific notion of the topic. Primary School 2, was more concerned with the pupils gaining access to the computer programs I had to offer. The teacher thought this would help them to develop skills that they otherwise might not have the opportunity to develop, as well as appreciating some of the ideas surrounding energy.

The Secondary school approach was different again. The first school used the occasion as an opportunity to try to motivate some of the students who had decided to opt out of Physics lessons in the fourth year. The teacher hoped that a new approach would involve the pupils more in their science lessons. A fair amount of ground work had already been covered with respect to the "scientific" nature of energy. He was looking to the work to broaden the pupils' ideas about energy and energy related problems.

The second of the two Secondary schools was very keen to take part in the research work, as they saw it as an opportunity of starting to use CEDRIC 2.1 within an energy teaching scheme, that might have use throughout the curriculum. However in the short term the work had to be stopped due to the fact that the majority of the pupils were boarders so that data for the program chosen was difficult to obtain. Nevertheless, a reasonable amount of information was collected from the school before the work ceased.

The research work and the teaching planned was therefore structured in a way that would be reasonably uniform so far as the type of data collected was concerned, yet diverse enough to fulfil the schools' needs.

In each school, the work started with the use of CEDRIC 2.1. This gave an opportunity to observe a piece of computer software being used with different ages and abilities, as well as to see how the pupils coped with the computer itself. All pupils were asked to record as much as possible of their work throughout the

project, so that a record of their work could be obtained for use as data.

Each class teacher had their own methods for their pupils to record this work, ranging from project books, to a file of relevant work completed during the time I was in the school.

The Table 6.1.1 below gives an indication of the types of data collected from each of the schools during the six week period of the project work:

TABLE 6.1.1

DATA and MATERIAL COLLECTED	PRIMARY SCHOOL 1	PRIMARY SCHOOL 2	SECONDARY SCHOOL 1	SECONDARY SCHOOL 2
GRID QUESTIONNAIRE A and B	/	/	/	/
SCIENCE REASONING TASKS	/	/	x	x
NOTES FROM LESSONS	/	/	/	/
TAPE RECORDINGS	x	x	/	/
PROJECT BOOKS	/	/	/	/
HOMEWORK	/	/	/	/
TESTS IN CLASS	/	/	/	/
MODELS PRODUCED	x	x	/	/
ASSIGNMENTS	/	/	/	/
MODIFIED CEDRIC INSTRUCTIONS	/	/	x	x
INSULATION SHEETS	/	/	x	x
PROBLEM SOLVING	/	/	/	/
RECORDS OF CLASS WORK	/	/	/	/
SUMMARY SHEETS	/	/	x	x

The form of the data collected varied, though pupils covered much the same work through different approaches. These variations will be discussed at length in Section 6.3.

Concentrating on CEDRIC 2.1 allowed me to devise many small experiments, such as problem solving, data collection, and data input into the computer.

Generally I was looking for evidence of whether the pupils could both understand and manipulate the information they were being presented with, sometimes with my help but predominantly by themselves. In this way it was hoped that the underlying problems of the program would come to light and generate further investigation.

Much of the data collected was in descriptive form. The Primary schools produced project books of various lengths, whilst the Secondary schools produced documentation of completed work and models.

The research set out to use the software to generate as much useful information as possible, with regard to pupils' conceptions of energy, their skills in terms of computer use, data collection, manipulation of data, the acquiring of new vocabulary, and the nature of problem solving within the context of energy problems.

6.2 FORMULATION OF ENERGY QUESTIONNAIRE

A method of establishing pupils' preconceived ideas about energy was required. Initially 6 pupils from Primary School 1, of mixed ability and aged between 10 and 11, and 12 Secondary pupils aged 13+ from a selective school were asked a series of questions on energy. These can be seen in Appendix 4 as 1P and 1S. The

Secondary pupils were asked further questions to see at what level they had approached the topic previously.

The questionnaires were completed under test conditions, and then later gone through in detail with pupils to see what they had found difficult or ambiguous. From this it emerged that:

- (a) The wording of some of the questions was too difficult;
- (b) Several questions were ambiguous;
- (c) The concepts of Kinetic or Potential energy were very difficult for the pupils to explain.

A complete record of the pupils' responses can be found in Appendix 5.

The main conclusion drawn from this first questionnaire was that the way the questions were worded, influenced too much the type of responses given. It was also difficult to understand exactly what it was that pupils were trying to say in these responses.

Although the Secondary pupils were more articulate, similar barriers of meaning and context were found.

Comparing the written scripts with the pupils' interviews it appeared that, at both Primary level and Secondary level, the pupils did not always mean what they wrote. This was a salient point in the construction of the second questionnaire. It seemed clear that the type of questionnaire required was one that did not need responses in the written form, as the responses were difficult to interpret and analyse coherently. What was needed was a type of questionnaire which obtained many answers from many questions on different aspects of energy, eg:

- 1 What kinds of thing need energy?
- 2 What types of things are a source of energy?

It was therefore decided to produce a questionnaire in which a set of objects were given, and questions related to various aspects of energy were asked about them, to which pupils could answer just Yes or No. I tried to cover the major points that related to energy, by using verbs most often mentioned by the pupils in the previous questionnaires. It was also important to consider that the questionnaire had to fulfil three major constraints:

- 1 To be easily understood by a wide age range;
- 2 To elicit the type of information I was looking for;
- 3 To enable easy interpretation of the responses obtained.

For these reasons a grid type of questionnaire was developed. It can be seen in Appendix 3. This questionnaire was designed so that the pupils only had to tick or cross an appropriate space. The sheets were then sent back to the schools and on this occasion the whole class was asked to participate.

There were 9 questions about each object:

Is it;

- 1 Something which can NEED energy?
- 2 Something which we can GET energy from?
- 3 Something which can USE UP ITS OWN energy?
- 4 Something which USES UP energy from other things?
- 5 Something which can STORE energy?
- 6 Something which can PASS on energy?

- 7 Something which can LOSE energy?
- 8 Something which can HAVE energy?
- 9 Something which IS energy?

The objects across the top of the grid were chosen by formulating a simple structure, divided into 4 main areas, as can be seen in Figure 6.1.1. These were based on comments made by the children, through the interviews, and the others were an arbitrary choice, in the sense that they were included to try to make the pupils think about energy in different ways eg tree, atoms, soil, and a warm room.

FIGURE 6.1.1 OBJECTS USED

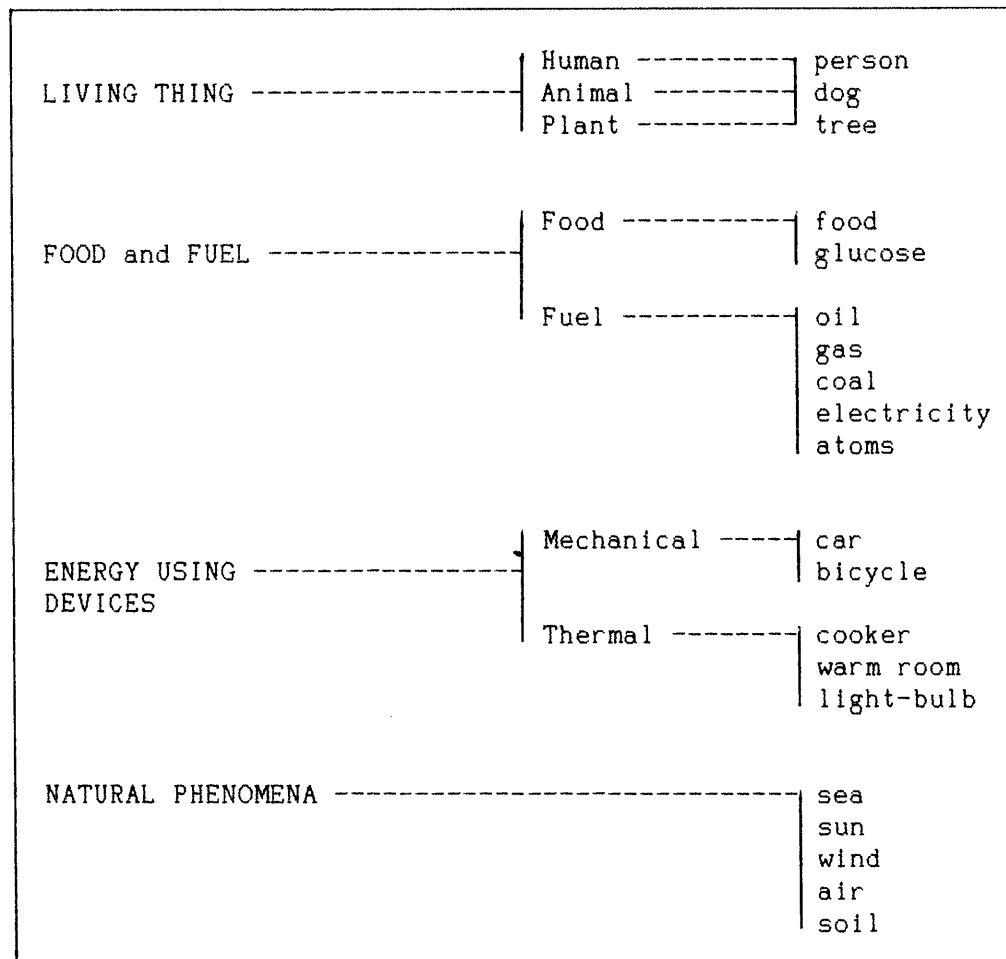

The questionnaire was administered by the class teacher who was asked to discuss the questions with the children only after the completion of the questionnaire itself.

Some pupils in the Primary school still found aspects of the questionnaire difficult, with respect to the meaning of certain words within a given question. The supervising teacher made the following comments:

"Question 8 was ambiguous, does HAVE mean RECEIVE or POSSESS? It would have been more beneficial if somebody could have gone through the answers given by each child and listened to their explanation as to why they interpreted the questions in a particular way and gave the answers they did".

The teacher also recorded one pupil's response to question 2 (get energy from).

"You could put a person on a bicycle attach a dynamo and a light bulb. The same could be true of water if it was controlled, but I interpreted the question as a natural provider of energy".

[William aged 10]

The teacher also reported that the pupils had difficulty in the actual manipulation of the grid. She therefore decided to read each question out in turn so that the pupils could fill in each line of the questionnaire before proceeding to the next one. In this way she ensured that all lines of the questionnaire were correctly filled in. This technique was then recommended to all the other schools taking part in the project. This slight alteration seemed to facilitate the mechanics of the grid itself.

6.3 THE ENERGY PROJECTS CARRIED OUT IN SCHOOLS

6.3.1 Introduction

Section 6.1 gave an overview of the work carried out in each of the schools. This section aims to give a more detailed description of the work conducted within each school during the six weeks of the energy project, to highlight the problems that arose from the work, how they were tackled, and what questions were left unanswered or created. As much of the project work was the same in each school, but the problems arising were different, a description of what was being looked for in all schools is given, in this way giving structure to the detailed description of each school.

6.3.2 Points Common to all Schools

CEDRIC 2.1 was used to see if pupils in their respective age and ability groups could cope with more complex situations than they had been used to, without having to enter into a great deal of "Scientific detail". It was important to try and see what methods, if any, the pupils used in trying to understand and hence cope with the work set them.

Each section of the program was either taught, discussed or demonstrated before the pupils used it themselves. During this time it was always on my mind to see if the children were trying to use what I had taught them or were trying to place the information that they had gathered into some form of coherent structure in their own minds. Questioning often brought out areas of doubt and

misunderstanding, and the introduction of the same information in a different format would from time to time help. Examples of this can be seen in Chapter 8.

A series of tasks were developed using CEDRIC 2.1. These included mathematical skills, explanation skills, and reasoning skills. It was hoped that through these various strategies a general picture of the cognitive skills, processes used, and levels of understanding of the pupils would be seen. The areas looked at in relation to the program included percentages, ie what this actually meant to the pupils, whether they could calculate their own percentages from the information that they had collected, and if so whether they understood the meaning of the results obtained and what use they put them to. Measurements and the calculation of areas, volumes, and DHL (Designed Heat Loss) were looked at to see if the pupils could actually do these calculations without the use of the program, and whether the program actually enhanced the learning processes that were required. When looking at the DHL of the pupils own houses the introduction of energy saving methods was considered and discussed. Various scientific concepts were introduced at this point such as the "conservation of energy", but it was not however put to the pupils in this way, but rather as of:

"What do you think is happening to all the energy, in the form of heat that is being supplied to the room?"

This led to discussions on the escape of heat from the room, and the fact that the temperature of the room might not remain constant, and how this could be rectified. For some pupils it became evident that this approach helped them to gain a clearer understanding of some energy concepts, as can be seen in their written documentation, discussed in Chapter 8.

It was also part of the research to see whether the program could fit coherently into the overall teaching scheme planned.

When using the program with the children I was trying to see whether they were using knowledge they already had to explain sequences of events that occurred in the program, or if they were making use of the knowledge they had just been introduced to in a coherent way, thus indicating possible areas of learning that might have taken place, as well as indicating successful use of certain parts of the relevant program.

6.3.3 Primary School 1

This school was chosen because it was accessible and the teachers were happy to co-operate with the research work. Its strong thematic approach to its teaching lent itself well to the research. Energy was to be taught as part of the theme "Energy and Man". The second half of the summer term (six weeks) was given to the project. Time was allocated each day for the pupils to conduct their work. I went twice a week to supervise the computer use.

The idea was to introduce the pupils to as many aspects of energy and its interpretation as possible. Many resources were acquired such as videos, computer software, booklets, myself, and an introductory talk on energy in the form of gas, by the British Gas Educational Services Department.

Gas was introduced to the pupils as an energy giving commodity. The aspects looked at included how it is formed, how it is extracted, how it is utilised, its impact on the environment, and ways in which its consumption could be reduced. Great emphasis was put on the saving of energy. This was introduced by a film called "The Wasteful Family". This particular aspect of the talk seems to have made a great impression on the pupils, as it appears as one of the main features in their written work. It was also a pertinent point to pick up and use, in terms of the computer software. It was at this point that certain children were chosen to participate in the use of the computer software.

Both the classroom teacher and myself taught the children throughout the project. The teacher supervised all the practical and creative elements, the Head Teacher taught a few science lessons, and I supervised the use of the computer. The aim of the teaching program was to see how and in what way the learning process developed, and to what extent the teaching program was actually affecting the pupils' conceptions of energy, and their acquisition of knowledge and skills.

The class was divided into approximately equal sections: those with the class teacher, those working with the computer program, and those who were doing other tasks related to the project that did not necessarily require teacher supervision, such as watching chosen videos. The groups rotated so that they were subjected to similar situations throughout the project. Due to the fact that the actual manipulation of the program took longer than expected, not all the children had the opportunity to use the computer program in depth, the computer only being available to the class for the two days a week I was in the school.

As much of the material and resources were provided by British Gas Educational Services, the work the children produced was orientated towards gas. This however did not deviate from the type of research I was trying to do. The project books the pupils have produced do indicate their ideas and concepts of energy. Their writing and drawings reveal many related conceptions.

The class teacher introduced the pupils to various elements of the work through discussions and investigation. She allocated approximately two sessions a day, which was the equivalent of about 80 minutes, for the project. Pupils were encouraged to look for information themselves, from resource books, videos, tapes and software (when available).

I took groups of children and introduced them to CEDRIC 2.1. Each group had a double session with me, this varying in time from about 60 to 80 minutes. The program involved data collection and analysis tasks, demanding a variety of skills at all levels of cognitive processing. The main aim was to see how and in what way the pupils would negotiate the program, from the point of view of meaningful learning, and from the point of view of the cognitive demands made upon them.

Within each group, I chose one pupil to instruct the others in the use of the program, after I had initially run through it with the group. It was interesting to observe the way this pupil and the others worked together. The "leader" read the instructions from the screen to the group and initiated a discussion as to what the answer should be, or how it could be obtained. It appeared that the leader used a consensus decision. This interaction between pupils gave insight into some of the areas they found difficult to understand and hard to fit into their own framework of ideas. Many of these were noted and discussed with them at a later date.

The introduction of CEDRIC 2.1 took longer than anticipated. It turned out that the documentation needed explaining in great detail before pupils could manage to use the program on their own. One complete morning session (80 minutes) was spent with each group, going through the documentation and how it was presented on the screen. I then worked through a pre-calculated example.

This aspect of simplification of the documentation was looked at in detail in the second Primary school. (As a part of this work new documentation was developed, which will be discussed in section 6.7)

The pupils were asked to use the data collection sheets provided to collect data for use with the program. This proved difficult as the documentation did not coincide with what was on the screen. I therefore gave the children a list of data to collect, as it appeared on the screen, so that they could put it into the program at the next lesson.

To bring the project to a close, I asked a series of questions to which they gave written responses. The questions related to the nature of the work done, how it was approached, the use of the various resources, and what they themselves had got out of doing it. I also asked what, if they were in my position, they would include and consider important in an energy project. The responses were both interesting and humorous.

6.3.4 Primary School 2

The work in this school differed from that described above in that I was working with a smaller group of 10 pupils. The teacher chose very able pupils, all of whom had passed selection to the Grammar school, for the project as he thought it was in their interest to learn about energy and the use of the computer programs. In this school I did all the teaching and supervising of the computer use. The

pupils were juniors (11+). Energy appeared twice a week for a double session. I went in for one of each of these sessions. In the remaining time the children were expected by their teacher to write up their work on their own. I was not always available when they required help. However they did have access to the computer whenever they wished within a given period on the time table. Due to the nature of the working of this particular classroom I found the written work variable in nature, ranging from well explained, logically written information to rather haphazard efforts. However the pupils did accomplish a great deal of work given the time and circumstances.

As described in Chapter 2 these pupils were initially introduced to the energy project through the computer program PEG. In order to initiate discussions on energy usage in the home it seemed appropriate to ask them what were the main points brought out in that program. The children were able to recall that the main idea was to control the internal temperature of the house despite changing conditions outside. It was interesting to note that in this discussion they themselves introduced terms such as heat energy, saving energy, draught proofing, double glazing, and insulation. It was apparent at times that these terms, although being used in the correct context, were used without any real understanding of their implications. At this point I asked the pupils exactly what they meant by these words and where they had learnt about them. During these interviews I tried to correct any misunderstandings they had by explaining the meaning

of each term, in the hope that they would be able to understand them more easily when using CEDRIC 2.1.

The pupils' written work started with a representation of energy both in their world and what it meant to them personally. Most of them chose to represent this information in the form of a flow diagram. They were then posed six questions by their own class teacher as a way of starting them on their project. These included:

- 1 What is energy?
- 2 Where do we get energy from?
- 3 How do we use energy?
- 4 How do we make energy?
- 5 When will energy run out?
- 6 How much energy is wasted?

Since the concept of energy within the context of home heating had already been introduced to the pupils in the introduction to the project work, I now wanted to see how they would adapt to having to gather their own data in order to use CEDRIC 2.1.

The data collection documentation supplied with CEDRIC 2.1 had already, in school P1, proved too difficult to use. I therefore decided to try to construct a simpler version of the documentation, in order to see if this could make the use of the program more possible for younger pupils. This required two attempts, before pupils could successfully collect the required data. (The two revised

sheets can be seen in Appendices 6 to 9. The pupils then went home and gathered as much of the information as possible. This proved to be much more successful than I had anticipated, the pupils being then able to enter the data without any help from me. They seemed to follow the program quite easily, processing their information in a logical and sequential way. The product of their work led to the DHL of each of their homes. The pupils were using skills they already possessed in order to manipulate the knowledge they were being introduced to. It therefore seemed pertinent to see just how much they had assimilated of the new knowledge they were gaining, and whether the information was being used in a logical and coherent manner.

The task I set was to design and construct their own home in a scaled down version using the information they had gained from CEDRIC 2.1. The aim was for each pupil to find their DHL and try to improve on it through the use of CEDRIC. This was to be achieved by constructing a model of their house using a shoe box. The box was to represent the basic layout of the house including windows doors etc. Insulation was to be represented by cotton wool, double glazing by cling film, the various surrounds of the window frames were to be represented by whatever the pupils thought appropriate. Each step of the exercise was recorded by the pupils in project books. Diagrams with explanations of various steps taken were given in order to show how their homes were being made more energy efficient.

It was possible for them to return home and explore the nature of the types of energy saving devices they had at home. They were encouraged to collect further data and incorporate it into their existing data in the CEDRIC database. This would then enable them to see how and in what way the DHL of their homes could be changed. The interesting factor here when discussing these points with the children, was that the way they interpreted their findings seemed to indicate that both prior knowledge and new skills were being used to interpret what had been shown on the screen.

There appeared to be a general understanding of the basic concepts of home insulation when I spoke to the pupils, yet if one looks at their written work it often implies the concepts but does not directly state them. An attempt to explore some of these discrepancies between the two areas will be made in Chapter 8.

The end product of this work was to be a house made from the shoe box, representing their home. However the pupils found the notion of scaling down very difficult, even in an approximate form, and it was therefore decided that the mere representation of the house in terms of the shoe box would be adequate. Their project books contained evidence of the prior planning, and understanding of aspects of heat conservation gained through using the CEDRIC program.

6.3.5 Secondary School 1

The aim of the energy project in Secondary School 1 was to see to what extent CEDRIC 2.1 could be used to make pupils think more about energy, and understand better what the related problems might be. This would then test the flexibility of the program and the concepts it was aiming to convey.

I was given a group of third year students who were no longer continuing their studies in physics in the fourth year of their schooling. The teacher hoped that a different approach to energy topics might encourage them to change their ideas and attitudes towards the topic generally.

My main concern was to elicit as many of the pupils' concepts, attitudes, notions and beliefs as possible prior to introducing them to the energy project and the use of the software. For this the energy questionnaire was used, together with a small question sheet on home insulation and various terms connected with energy saving devices within the home. In this school, the aim was for pupils to use the software with as little help from me as possible. I was trying to see how they would use the information and knowledge they were being introduced to in the tasks set during the project.

The pupils had been taught about energy in the weeks preceding my visits to the school. I was asked to try to incorporate some of these ideas into the project work.

Energy within the home was introduced as a way of finding out what pupils' ideas were as to energy "conservation", uses of energy and energy transfer. The initial discussion was recorded for future analysis.

Having discussed energy around the home the pupils were introduced to CEDRIC 2.1. The actual running of the program caused them no problems, as they seemed to have all the practical skills required for such a task. The group took about a double lesson to appreciate exactly what was required of them to obtain a reasonable set of results. The discussion on home insulation plus the introduction to the program took two double lessons.

The pupils were then asked to take the Household data sheet from the (old form) CEDRIC 2.1 package and collect the relevant information so that a DHL value could be obtained. The pupils were set this as homework. The following lesson they were asked to put their data into CEDRIC 2.1 and to record the information presented by it. Each pupil was told to record each other's details so that comparisons could be made. (A printer was not available). This approach had the advantage that the pupils made instantaneous comments about the figures produced on the screen.

It was interesting to note that some pupils found manipulating the data they collected difficult, eg when asked for the total area of the windows in their homes, they had only recorded the area of one, hence the DHL

value calculated at the end of the program was not accurate. This was picked up by the more aware in the group. They then gave suggestions such as:

"For now approximately how many windows do you have, lets say they were all the same size, that way we can carry on".

When all the pupils had obtained results for their home a tape recorded discussion was held. This discussion was initiated by me, with help given in the form of new knowledge, and explanations in areas that concerned them. There were questions about specific terminology, such as:

"What is a thermal break, and how does it work?"

"What is cavity wall insulation, and why do we need it?"

The aim here was to interest the pupils sufficiently that they might want to investigate the problematic areas in their own homes. They were encouraged to use the information collected about their homes as well as the new knowledge they had acquired about insulation to think about improving the overall effectiveness of their home's energy consumption.

As with the Primary schools the task set was to develop a model house made from a shoe box, to represent their homes with energy saving modifications included. Here too the pupils found scaling down very difficult, so that mere representation was accepted, in order not to lose enthusiasm. Each step of the work was recorded. These

reasons and explanations for each decision made regarding the use of insulating material or any other factor that might change the DHL of their own house.

documents included diagrams and explanations for each decision made regarding the use of insulating material or any other factor that might change the DHL of their own house.

The culmination of this work was that the pupils constructed models of their homes with comprehensive written documentation explaining the reason for their design and the use of the chosen types of insulation.

The pupils were also encouraged to refer back to CEDRIC 2.1 at all times to see if their ideas were correct, evidence of this being in their written work.

6.3.6 Secondary School 2

This school presented many problems, due to the nature of the school itself, and the project had to be postponed. The fact that School 2 had a high proportion of boarders was a major problem when it came to collecting data for CEDRIC 2.1. I taught one double lesson a week of 80 minutes, as part of their combined science course. The group of pupils I was given were of low ability and had a poor standard of maths. This provided a way of testing the flexibility of CEDRIC 2.1, in that using it with low ability pupils helps to find the limits of CEDRIC 2.1 with respect to maths.

Before attempting to teach the group I gave the pupils the energy questionnaire.

The pupils were introduced to CEDRIC 2.1 through the original data collection sheets. I initially went through the documentation with them explaining what was required and how each section could be calculated, so that the right information could be put into the computer. The pupils were then asked to obtain this information. Out of the group I had only two who were day students, and therefore the collection of home energy data was limited to those two pupils. The rest were set tasks relevant to certain areas of the school, ie to find the area of classrooms, how many classrooms there were in the school, what type of heating the school had.

In the next lesson we looked at the information collected by two pupils. The processing of this information took a great deal longer than expected. The discussion took the form of comparisons between the school as a building and the houses of the pupils who had collected data.

It was at this point that the project had to stop (the pupils had internal examinations to take and the teacher thought it best to postpone the work to a later date). However the pupils did fill in the energy questionnaire, and complete enough work on CEDRIC 2.1 to give some indication of how it could be used with less able children.

6.4 EXTENSION WORK ON CEDRIC

An extension to this work has led to a cross-curricula competition initiated by British Gas South Eastern Region. The competition is called "A Style For Living", and incorporates CEDRIC 2.1 being used to make a pre-specified house energy efficient, using the DHL part of the program. The response to the approach has been very encouraging, with some 245 schools in Kent alone entering (approximately 2200 pupils). The area finals are in May 1990 and the Regional finals in July 1990. Being one of the judges will enable me to have access to the work completed. (Although too late to use in the present analysis it will give a good insight into how the teaching strategies evolving from CEDRIC 2.1 can be used).

6.5 SCIENCE REASONING TASKS (CSMS)

The Science Reasoning Tasks (SRT) are tests for assessing the cognitive levels of children, or use of Concrete and Formal Reasoning strategies, developed by Shayer (1978). They can be used by science teachers without professional training in Piagetian studies. A class of thirty pupils can be tested on each task in 35 to 50 minutes. There is evidence of their validity and reliability. The tasks are criterion rather than norm-referenced, in that the Piagetian level of each subject is estimated directly.

The tasks were primarily developed to be used as an adjunct to curriculum development in science teaching. The SRT's provide a way of looking at curriculum material, with a view to possible evaluation, by making a match between target population and course material. Within the energy project, tests on individual

classes were made to estimate the range of cognitive levels, to give evidence relevant to understanding difficulties with software.

The tasks were designed to be used in schools for pupils between the ages of 9 and 16. Tasks III to VII are taken from "The Growth of Logical Thinking" [Piaget and Inhelder (1958)], and are aimed at the older pupils. Tasks I and II as used in the Energy project are aimed at the average or above average pupil down to the age of 7. The SRT's were only able to be given to the Primary school children.

-

As discussed in Chapter 4 , it was decided that the SRT's might be a useful way of considering the the pupils cognitive levels, and that the Shayer Taxonomies could be a valid way of looking at levels of difficulty in the software and its documentation. A comparison of the two sets of observations would give a possible evaluation of the software.

-

The two tests chosen were:

- (i) Spatial Relationships. In this task pupils draw their responses. It is therefore particularly suitable for the younger child, and those with writing difficulties.
- (ii) Volume and Heaviness.

1 Spatial Relationships

This is based on "The Child's Conception of Space" [Piaget and Inhelder (1956)], and tests the pupils' perception of spatial co-ordination. Four situations are taken and each may be scored at a number of levels.

- (a) An empty jam-jar is held up and each pupil is asked to draw it in cross-section, imagining it half-full of water. Then it is tilted to 45 degrees, and the pupils asked to draw it as it would look if it were still half-full of water. Finally, it is held horizontally, and the same question asked.

- (b) The children are asked to draw the outline of a mountain, and on its side draw a house and some trees.
- (c) A jam-jar with a plumb-line hanging inside is provided for each child, who is asked to handle it. Then the same question is asked as in (a).
- (d) The child is asked to imagine that he is standing in the middle of a long straight road going away into the distance, and either side of it are rows of trees. He is asked to draw it as it would look.

Depending on the item scores, an overall assessment on this task can range from pre-operational (1B) through to late concrete (2B), with an additional scoring of 2B+.

[Taken from Shayer (1978) p8]

2 Volume and Heaviness

"This is based mainly on 'The Child's Construction of Qualities' [Piaget and Inhelder (1974)], and was chosen as being particularly suitable for the range of measurements 2A to 3A. Task II is hierarchically organised, with each item scored right or wrong. The first two items are the classical water-pouring tests from Chapter 1 of "The Child's Conception of Number" [Piaget (1952)] and the next is a substance-conservation question based on maize being "popped" in front of the class. These test conservation of substance, an early concrete operational concept (2A). The next seven are all scored as late concrete (2B) items, and involve intuitive density and water-displacement concepts based on a block of plasticine being lowered into water in measuring cylinders, having been distorted in various ways. Then there is a 2B/3A item in which pupils are asked to hold a block of brass and a block of plasticine of the same dimension, and asked how the amount of water they would displace would compare. Finally there are three 3A items requiring an analytical concept of density for their solution".

[General Guide, Shayer 1978 p9]

Both tests sheets can be seen in Appendix 10. As with all SRT's the administration of these tasks require the active involvement of the teacher.

6.6 OVERVIEW

In this Chapter, I have tried to give an account of the way in which the Energy Project was carried out in the schools. Four schools took part in the research, two Primary and two Secondary, encompassing some 100 children of varying ages and abilities. These included pupils between 9+ and 14+. All schools came from urban areas: two from middle class areas with well equipped schools, and a mixed catchment area, one not so well equipped school, and a residential type school, with good computer facilities. However the nature of the last school did not fit with the type of project that was being offered, so that the project was stopped prematurely.

The energy project itself comprised several elements. The first was to introduce pupils to a piece of energy software, CEDRIC 2.1. This involved them finding data about their homes, and putting this information into the computer. Tasks were set to see how much information the pupils had acquired, and the degree of understanding obtained through its use.

Through using the program it became evident that some new form of documentation was required if the younger pupils were to gain anything from its use. The nature of the new documentation was based on the needs of the pupils at the time. This approach showed that CEDRIC 2.1 could be completed by the pupils, giving a possible way of approaching the teaching of energy and energy conservation in the home. It did also seem that pupils of all ages could

assimilate the information from the program with varying degrees of help, depending on their ages and abilities.

In order for the project to have the same basis for all the pupils a questionnaire was developed, so that pupils' pre-conceived ideas on energy could be found prior to them starting.

6.7 APPENDIX TO CHAPTER 6

The Development of new CEDRIC 2.1 Documentation for the Younger Pupil

As mentioned in section 6.3 the documentation that went with CEDRIC 2.1 program appeared to be difficult for younger pupils to negotiate. It was therefore thought useful to develop new documentation. This was attempted in Primary school 2, and then further extended for British Gas, within the same school. (This has led to a new set of documents being published and issued with CEDRIC).

The original documentation for the program was difficult for several reasons:

- 1 The data to be collected was not in the same order as required by the program. Hence when pupils had collected data they were continually turning pages to find the required information. This led to input errors from younger pupils.
- 2 Much of the data needed required some form of mathematical manipulation, yet very little guidance was given on how to do this. For example the total areas of windows were required, but there was no indication as to what measurements needed to be taken in order to achieve this.
- 3 The documentation did not allow adequate space for all the information gathered to be recorded prior to entering it into the program.

- 4 Some of the language and terms used were not familiar to the younger pupil, (for example "thermal break" and "cavity wall").

These problems came to light in Primary School 1, and were reinforced in Primary School 2. The first attempt at making gathering data easier was designed by the class teachers. This enabled the pupils to gather a certain amount of information but not enough to obtain an accurate DHL figure. The teachers' version can be seen over.

Figure 6.7.1 CEDRIC HOUSEHOLD DATA COLLECTION SHEET (Attempt 1, By Teacher 1)

<u>NAME</u>		<u>ADDRESS</u>	
<u>CEDRIC HOME NUMBER</u>		<u>REGION</u>	
<u>TYPE OF DWELLING</u>		<u>AGE OF DWELLING</u>	
Detached	<input type="text"/>	Pre 1914	<input type="text"/>
Terraced	<input type="text"/>	1914-1939	<input type="text"/>
Bungalow	<input type="text"/>	1940-1960	<input type="text"/>
Flat/Maisonette	<input type="text"/>	1960-Now	<input type="text"/>
None of these	<input type="text"/>		
<u>SIZE OF DWELLING</u>		<u>GROUND</u>	
FLOOR AREA	<input type="text"/>	FIRST FLOOR	<input type="text"/>
		SECOND FLOOR	<input type="text"/>
ROOF AREA	<input type="text"/>		
HOW MANY WINDOWS WITH DOUBLE GLAZING?		<input type="text"/>	
AREA	<input type="text"/>		
WITHOUT DOUBLE GLAZING	<input type="text"/>	AREA	<input type="text"/>
<u>EXTERNAL WALL</u>			
Solid Brick	<input type="text"/>	Cavity +1976	<input type="text"/>
Stone/Concrete	<input type="text"/>	-1976	<input type="text"/>
Loft Insulation	Yes or No		
<u>HEATING</u>			
Gas Fire	<input type="text"/>	+ CH	<input type="text"/>
Electric Heater	<input type="text"/>	+ CH	<input type="text"/>
Solid Fuel Fire	<input type="text"/>	+ CH	<input type="text"/>
Central Heating Only	<input type="text"/>	+ Other	<input type="text"/>
<u>CENTRAL HEATING FUEL</u>			
Gas	<input type="text"/>		
Electricity	<input type="text"/>		
Solid Fuel	<input type="text"/>		
Oil	<input type="text"/>		
Communal	<input type="text"/>		
None	<input type="text"/>		
<u>NUMBER OF PEOPLE LIVING IN DWELLING</u>		<input type="text"/>	

It seemed clear to me that pupils would need a more comprehensive data gathering sheet than the one above, if the project was to continue successfully. I tried to design a sheet that would simplify the nature of the data required, yet still satisfy the needs of the program, as well as giving the pupil some idea of how to find the information needed.

The next sheet I developed tried to place the data required in an appropriate order for the children to collect. Although they found this sheet easier to follow they still required a great deal of help with certain aspects, such as calculating the area of the floor space or volume of the house. For the purpose of the continuation of the project the following data collection sheet was used.

FIGURE 6.7.2 CEDRIC 2.1 DATA COLLECTION SHEET 2.

NAME:

ADDRESS:

CEDRIC HOUSE NUMBER:

REGION

TYPE OF HOUSE:

AGE OF HOUSE:

SIZE OF HOUSE

Number of Floors

Area of Floors First Floor

Second Floor

Third Floor

Area of Ceilings

Number of Windows

Area of Windows

How many windows are double glazed?

How many have wooden frames?

How many have metal frames?

How many are single glazed, with wooden frames?

How many are single glazed, with metal frames?

How many people live in your house?

What type of heating do you have?

Do you have loft insulation?

Do you have any draft proofing?

What is your house built with?

Does your house have cavity walls?

Does your house have concrete or wooden floors?

Does your house have cavity wall insulation?

The above data sheet served the purpose of collecting sufficient data to continue with the project, but it did show that further work was needed on the documentation in order to achieve the collection of data easily and efficiently by children on their own.

The project work was complete at this school. However I returned at a later date to continue the improvement of the data collection sheet. I was fortunate to be able to work with the same set of pupils who had completed the energy project. In this way the program and documentation did not have to be explained over again.

Discussions with the pupils led me to think that in order to make the data collection sheets self-sufficient, it would be necessary to include hints as to how to find or calculate the required information within the documentation. This led to the idea of having diagrams to show how (for example) to calculate the area of a two-storey house. The instructions needed to be simple and sequential, with space for the child to record the results of each step so that all the information would be at hand to complete any calculations that were necessary. In this way the teacher could also see how the child had collected the information, and where mistakes might have occurred.

It was at this point that British Gas showed further interest in the documentation I was trying to develop. The first draft appeared to show some success with the pupils who trialled the data gathering process. The sequential flow of the information seemed to be helpful, as pupils thought the idea of having a

shaded box for their final result made it easier for them to put information required into the program. This document was then taken to British Gas Educational Department. They wished to publish the document as part of the CEDRIC 2.1 package but wanted the document to be more pictorial, and also to fit in with their concept of the character "HOLMES" who "homes in on" things to get particular facts. The documentation evolved as a result can be seen in Appendix 11.

This new pictorial version was then taken back to the two schools used in the pilot study and again trialed. The character Holmes was found entertaining by the younger pupils, and they found it easier to collect the required data than before. Having done so the children seemed to find no difficulty when inserting it into the computer, finding it relatively easy to check what they were doing at each stage, since the screen on the documentation matched the screen they were looking at when entering the data.

This new documentation gave the impression that it facilitated the use of CEDRIC 2.1 with younger pupils. There has been insufficient time to trial the documentation on less able pupils. Even so, it has been adopted and published by British Gas.

Chapter 7

DATA ANALYSIS ENERGY QUESTIONNAIRE

7.1 Introduction

The data analysis is divided into three main sections, each dealing with a particular aspect of the data collected. These are the Energy Questionnaire (this Chapter), The Science Reasoning Tasks (Chapter 8, 8.1) and the Pupils' Work, (Chapter 8, 8.2). It will describe the results of the analysis, and show some connections between the findings.

7.2 Energy Questionnaire

The questionnaire was given before and after teaching a six week topic on energy studies in each of the four schools. The purpose of the questionnaire is discussed in detail in Chapter 6, section 6.2. It was completed by all pupils. The questions were presented on a grid, to be filled with a tick or a cross for all objects, on each aspect of energy, taking each aspect in turn.

7.3 Rationale

The aim of the questionnaire was to find a way of eliciting how the pupils were thinking about energy. By choosing a questionnaire that required only Yes/No answers, about a wide variety of entities, related to nine aspects of energy, it was hoped that a structure of the pupils conceptions of energy could be identified.

7.4 Analysis of Data

It is important here to recall the aspects of energy that were chosen for the questionnaire (Figure 7.4-1), and the objects used (Figure 7.4-2).

FIGURE 7.4-1 ASPECTS OF ENERGY CHOSEN		
Being energy	┌	it IS energy
Storing energy	┌	it can HAVE energy it can STORE energy
Needing energy	┌	it can NEED energy
Using energy	┌	it can USE UP ITS OWN energy it can USE UP energy FROM OTHER THINGS
Giving energy	┌	we can GET energy from it it can PASS ON energy
Losing energy	┌	it can LOSE energy

9

FIGURE 7.4-2 OBJECTS USED IN ENERGY QUESTIONNAIRE

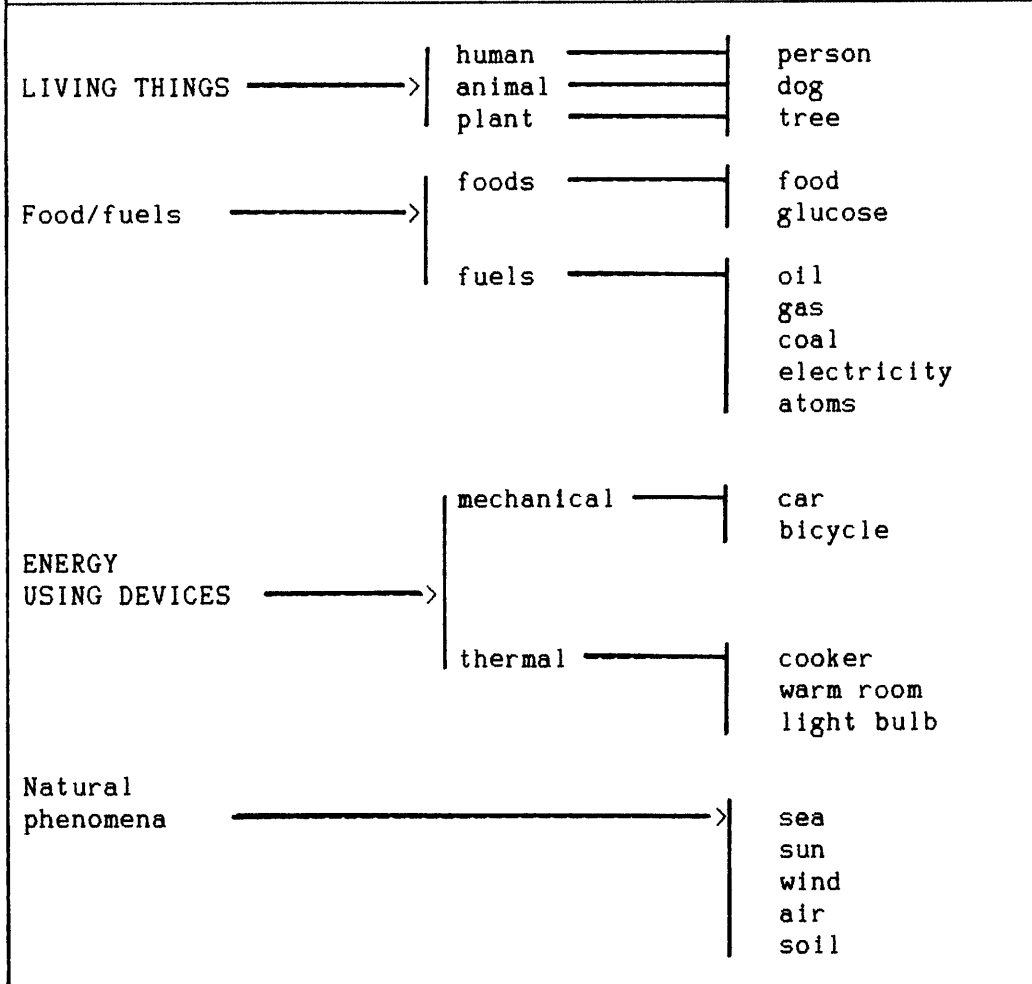

(The way pupils responded to these questions can be seen in Appendix 12).

The grid itself gave no indication as to why the pupils ticked or crossed the appropriate boxes. It was therefore necessary to see if there were any patterns in the way the objects were regarded.

7.4.1 Analysis of Questionnaire Prior to Teaching

For ease of discussion the younger pupils will be discussed first, followed by the older pupils.

Younger Pupils

Three main conclusions will be drawn for the younger pupils; that they see energy as related to:

- (a) Consumer/Source;
- (b) Can make things act on own or be used to act;
- (c) Are animate or inanimate.

Consumer/Sources

A starting point for the analysis used Multidimensional Scaling (MDS). This showed how the entities grouped together. The MDS gives a map in two or more dimensions using "distances" as a relative guide. The correlations between the entities using the frequencies of responses on the nine aspects, were converted into "distances" [1-correlation], using the "distance" only ordinally. Here the Euclidean distances between points on the map reproduce as well as possible the order of the "distances" taken from the correlations. In the case of the younger pupils, two dimensions explained 99% of the variance in the ordering of the distances, with a low Kruskal stress of 0.024. Figure 7.4-3 shows the two dimensional scaling map of the objects. A more detailed account of MDS can be found in Appendix 19.

Figure 7.4-3

Multi-dimensional scaling: younger pupils

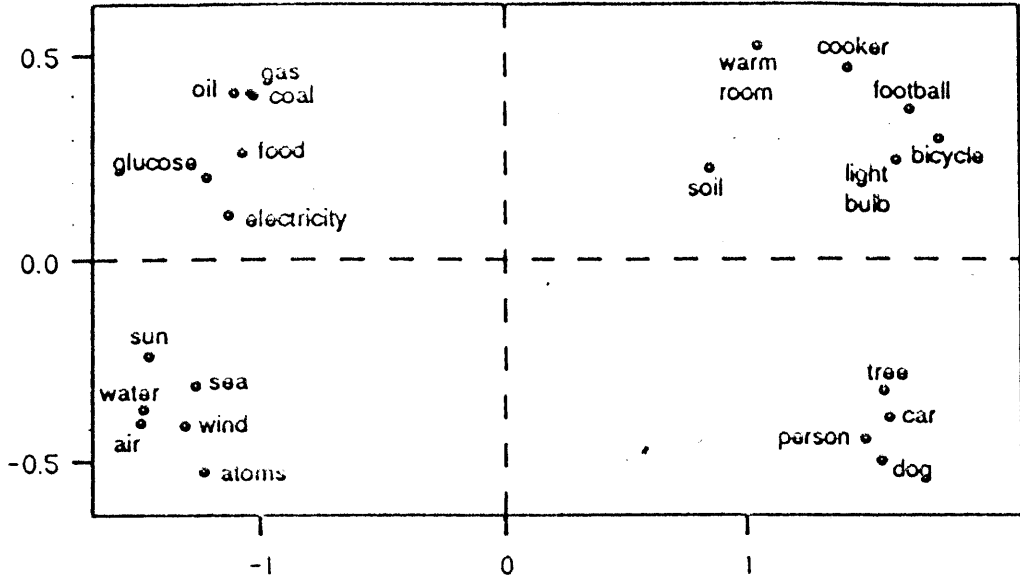
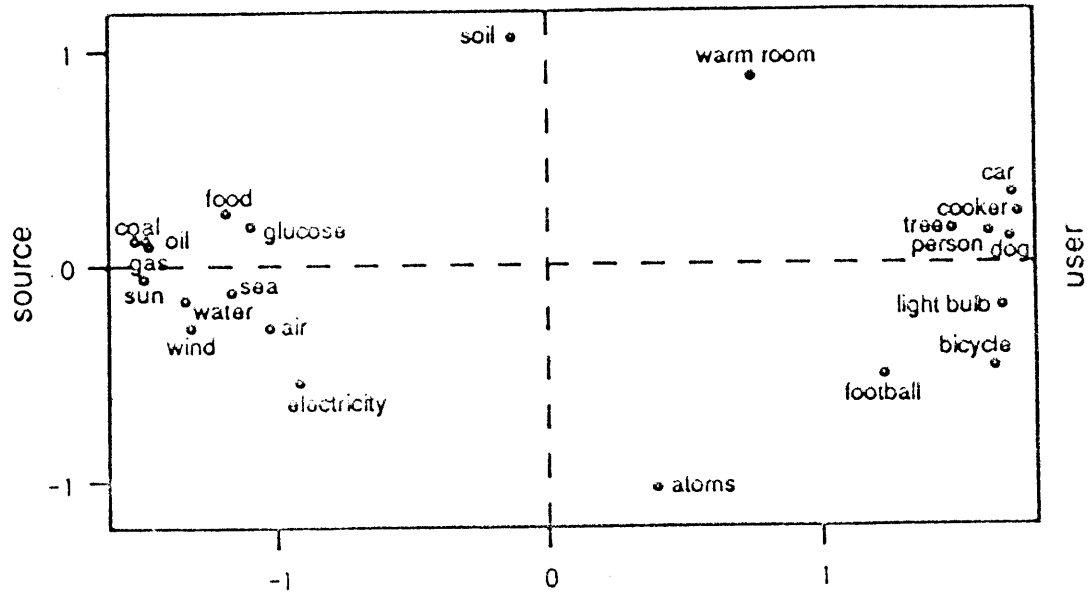

Figure 7.4-7

Multi-dimensional scaling: older pupils



The result is rather simple. In Figure 7.4-3, the horizontal dimension features strongly, dividing the entities into two distinctive groups. However it can be seen that the vertical dimension also divides the entities, in this way giving four groups. It is also noticeable that these resemble closely those incorporated into the selection of entities in Figure 7.4-2. However, small discrepancies do appear, such as the car which is found in the groups of living things; soil found with energy using devices, and atoms (which were meant to represent nuclear fuel) found with natural phenomena.

The interpretations given to the dimensions were identified by considering the percentage of "Yes" answers for all entities for each aspect of energy, (Figure 7.4-4). In this way it is possible to characterise the differences between the four groups. For ease of interpretation the entities have been re-ordered into the four groups.

The main dimension (horizontal) is clear in its interpretation. The entities falling in the groups "living things" and "energy using devices" fall to the right in Figure 7.4-3, and appear in Figure 7.4-4 as those entities most often "needing energy" and "using energy" from other things; but not as things that "give energy", "pass on energy" or "ARE energy." However on the left of Figure 7.4-3 the entities in the groups Foods and Fuels, and Natural Phenomena are found, and are represented in Figure 7.4-4 with a complementary set of properties: things which can "pass on energy", "we get energy from them", and "ARE energy." However they are rarely seen as "needing energy", or "using energy from other things."

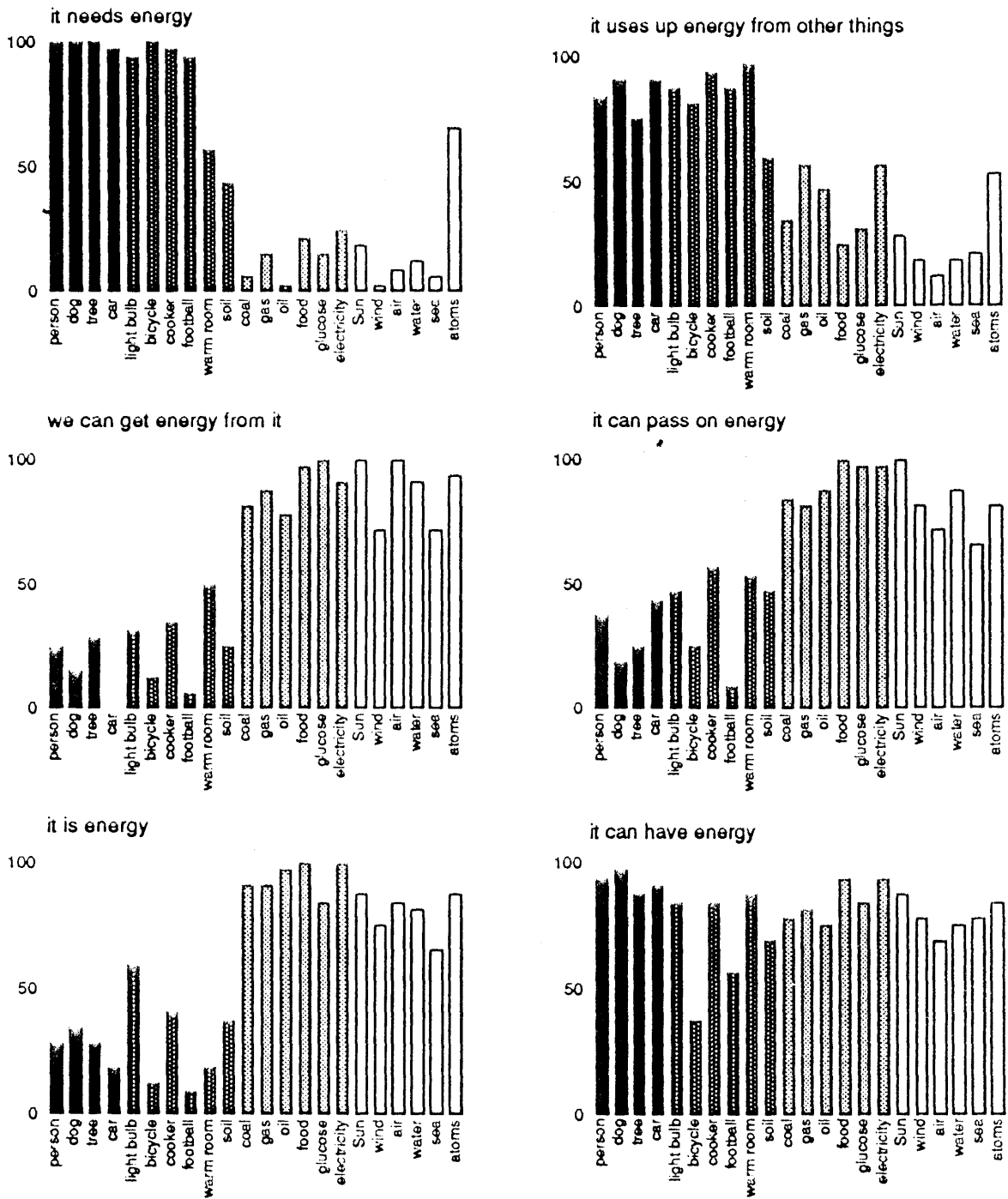

Figure 7.4 Percentages of 'yes' answers for entities: younger children

Figure 7.4-4 Percentages of 'yes' answers for entities: younger children.

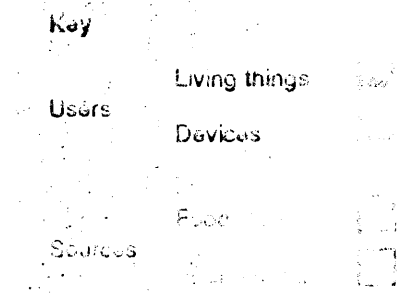
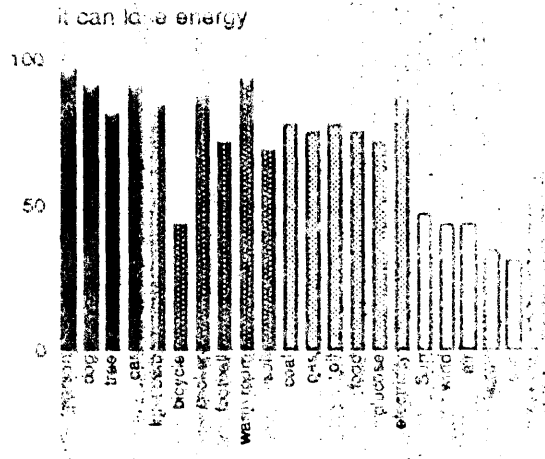
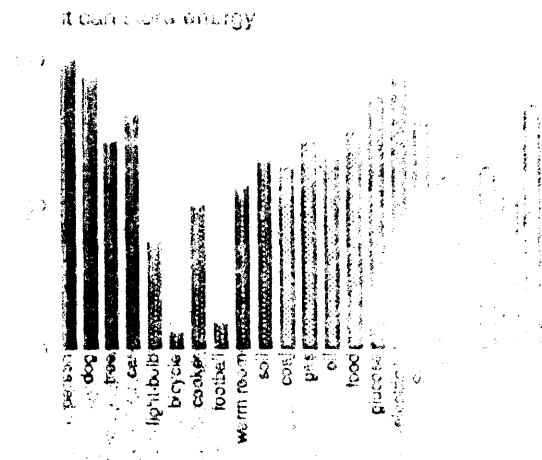
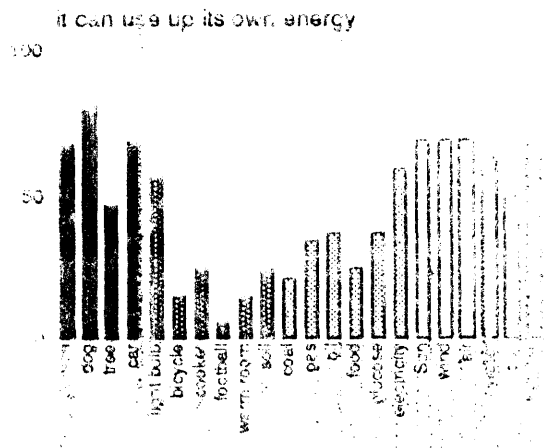

Figure 7.4-4 Percentages of 'yes' answers for entities; younger children (continued)

Figure 7.4-4 Percentages of 'yes' answers for entities; younger children (continued)

Thus the horizontal dimension appears to be interpretable as Consumer/Source, where the consumer category includes Living Things (person, dog, tree) plus car, as well as energy using devices such as football and warm room, and possibly soil. Things seen as sources are Foods and Fuels, (glucose, gas, oil, etc) and Natural Phenomena (wind, sun, sea).

It is interesting that the four groups cannot be distinguished by the aspect "it can HAVE energy." This can be seen in Figure 7.4-4. However a few exceptions do occur, the football and the bicycle, and perhaps water, which unlike almost all other entities are less often seen as having energy.

The second dimension, which is weaker, appears to divide the entities in a rather more complex way. A possible first interpretation of this could be as "Acts on own"/"Used to act." This derives from the fact that Living Things and Natural Phenomena can be distinguished from Foods and Fuels, and Energy Using Devices, by the aspect "It can use up its own energy" as seen in Figure 7.4-4.

It may be that this dimension is concerned with those entities that can or cannot use their own energy, things that can "Act Alone" as opposed to those which are "Used to Act." The interpretation given to "Act on Own" and "Used to Act" could be as follows:

"Act on Own" - The entity is visibly seen to have energy, such as a person, dog, and car, they are all seen to move

freely. The sources of energy, such as sun, water, and sea, are all seen as visibly having energy.

"Used to Act" - Here something must be done before energy is apparent. Each entity has to be acted on before energy is visibly used. A simple dot plot analysis identifies the aspects on which entities in a given group are frequently or rarely chosen. Figures 7.4-5 (a, b, c, d, e) show entities in each group highlighted. Table 7.1 gives an indication of how the notion "Act on Own" and "Used to Act" were distinguished.

TABLE 7.1 (A): DOT PLOT ANALYSIS	
SOURCES OFTEN SEEN AS	We get energy from it, it passes on energy
CONSUMERS ARE RARELY SEEN AS	It is energy
SOURCES ARE rarely SEEN AS	It needs energy, uses up energy from other things, it loses energy
CONSUMERS ARE OFTEN SEEN AS	
ACT ALONE OFTEN SEEN AS	It uses its own energy. it can have energy, it can store energy
USED TO ACT RARELY SEEN AS	

TABLE 7.1 (B): SUMMARISING THE NATURE OF OBJECTS IN THE 4 GROUPS

LIVING THINGS	CONSUMER	ACT ALONE
FOODS AND FUELS	SOURCE	USED TO ACT
ENERGY USING DEVICES	CONSUMER	USED TO ACT
NATURAL PHENOMENA	SOURCE	ACT ALONE

FIGURE 7.5 - DOT PLOTS OF RESPONSES WITH GROUPS DISTINGUISHED BY MOS HIGHLIGHTED.

(a)

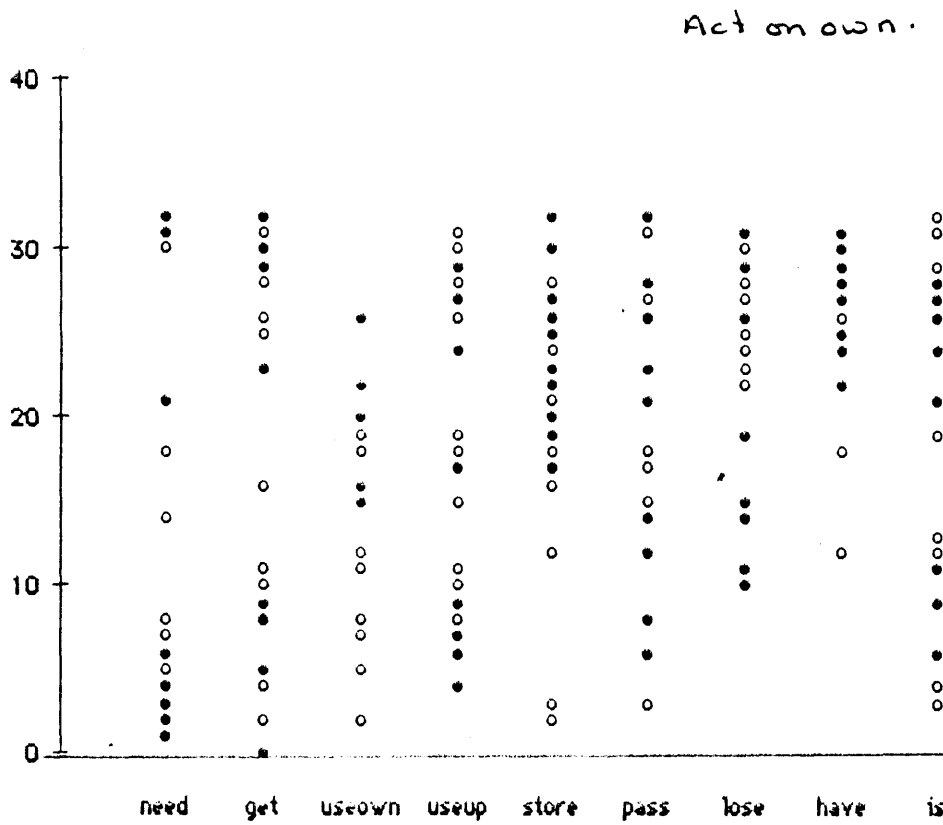

(b)

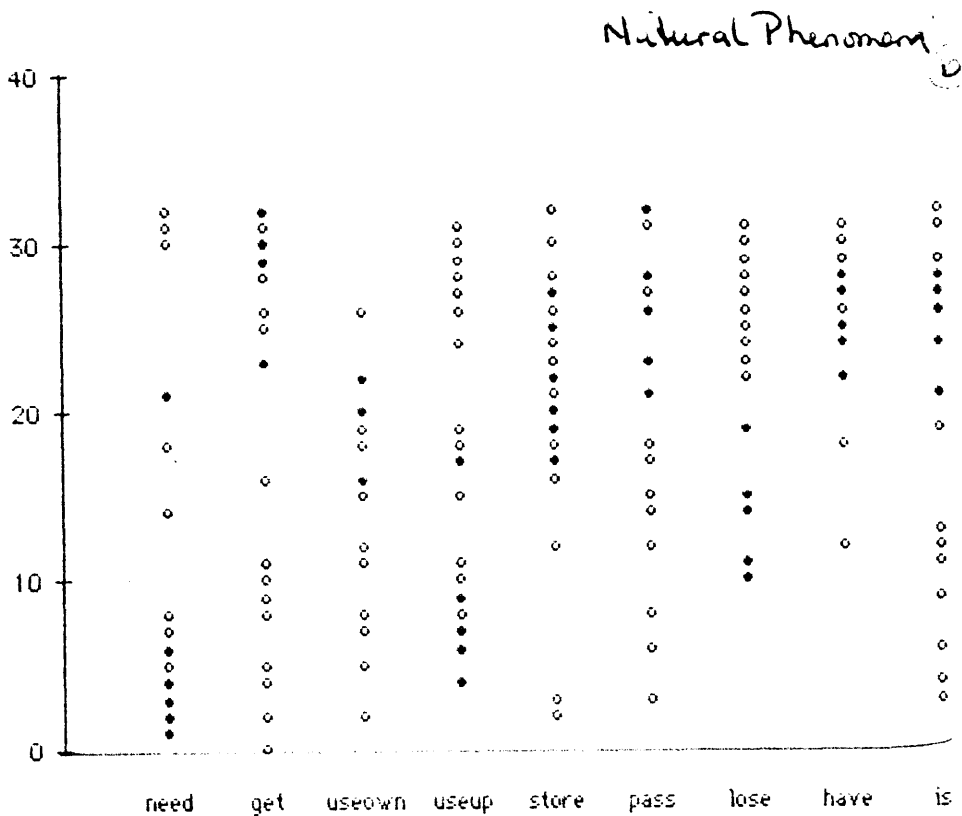

(c)



Fuels

(d)

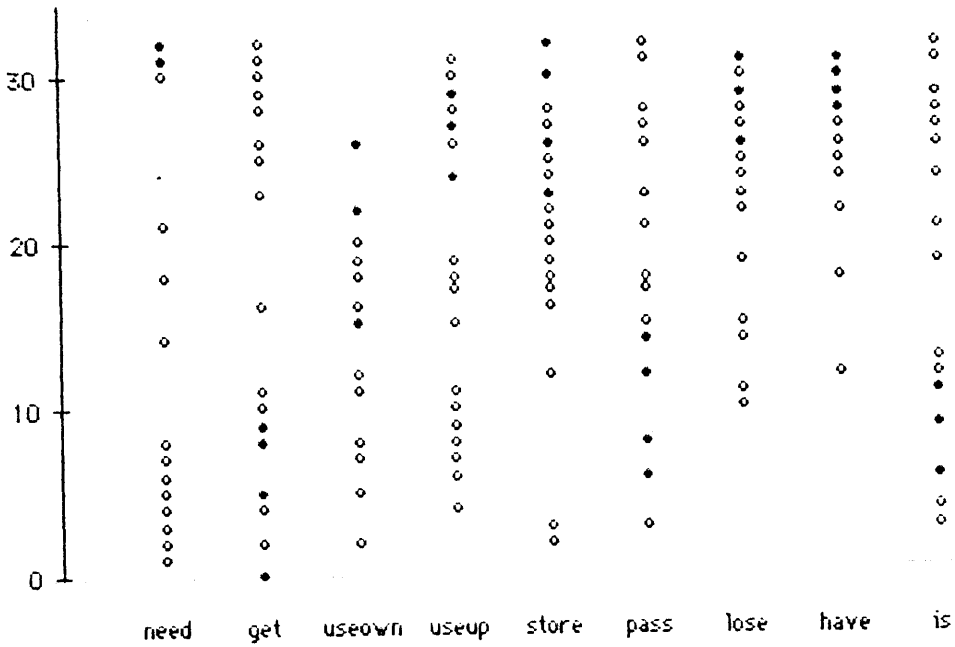

Living things

(e)

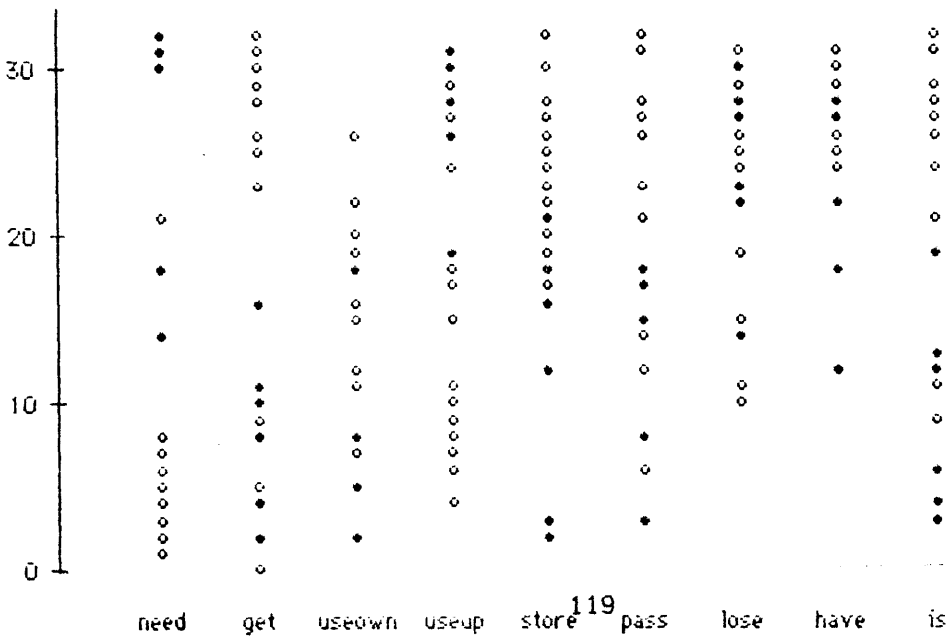

Non living things

The aspects were then separated into four groups and three features, as shown in Table 7.2.

TABLE 7,2

OBJECT CHARACTERISTICS; (HIGH = +) (LOW = -)									
FEATURES	GIVING ENERGY			CONSUMPTION/LOSS			POSSESS OWN ENERGY		
GROUPS	GET FROM	PASS ON	IS	NEED	USE UP	LOSE	USE OWN	HAVE	STORE
LIVING THINGS	-	-	-	+	+	+	+	+	+
FOODS/FUELS	+	+	+	-	-	-	-	-	-
ENERGY USING DEVICES	-	-	-	+	+	+	-	-	-
NATURAL PHENOMENA	+	+	+	-	-	-	+	+	+

From Tables 7.1 and 7.2, it can be seen that energy using devices are rarely seen as storing energy, and natural phenomena are rarely seen as losing energy. It is possible to say that USERS which are also USED to ACT do not store energy, while sources which ACT ALONE do not lose energy. This is also reflected in the second dimension where the entities are concerned with the aspects "losing energy" and "storing energy."

A summary of these notions is given in Figure 7.4-6:

FIGURE 7.4-6 SUMMARY OF INTERPRETATIONS ON 2 DIMENSIONS	
NOT USE OWN	
Food and fuels	do not store energy energy using devices
SOURCE	USERS
natural phenomena do not lose energy	Living things
USE OWN	

Analysis of Older Pupils

The older pupils' data was subjected to the same type of analysis. Figure 7.4-7 shows the MDS map corresponding to Figure 7.4-3 for the younger pupils.

The obvious similarity between the two sets of pupils is the main horizontal dimension. A test with Individual Differences Scaling using INDSCAL confirms this. The distinction in this dimension still remains SOURCE/CONSUMER, as with the younger pupils, as can be seen in Table 7.3 (derived from figure 7.4-8).

TABLE 7.3 ASPECTS WHICH DISTINGUISH ENTITIES		
DISTINCTION	SEEN AS	NOT SEEN AS
USERS	needing energy using up energy from other things losing energy	things from which we get energy pass on energy are energy
SOURCES	things from which we get energy things which pass on energy things that are energy	need energy use up energy from other things lose energy

There does not appear to be a second dimension for the older pupils. Three entities might contribute to such a dimension, (soil, warm room, and atoms) but it seems more likely that their position is such because they correlate very weakly with the majority of the other entities and with each other. Thus where the younger pupils distinguish four groups of entities, the older ones do not.

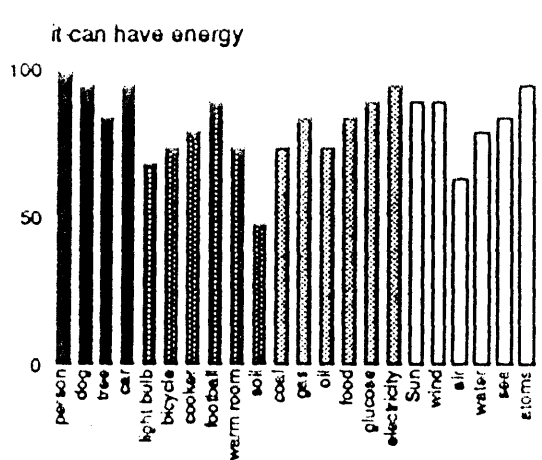
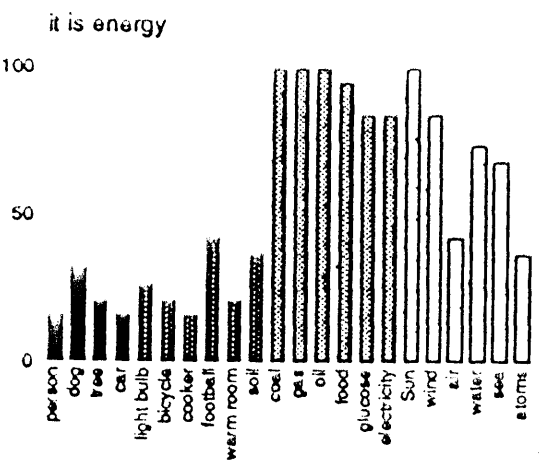
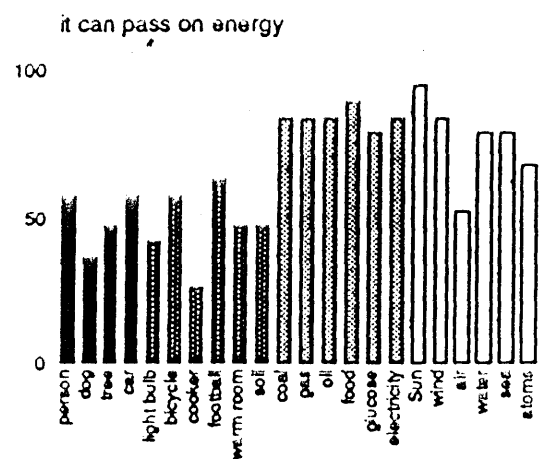
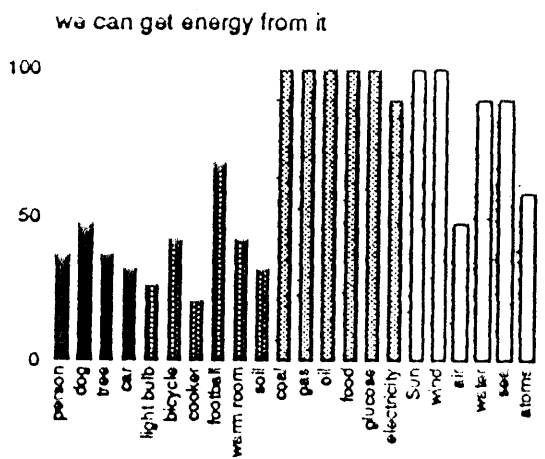
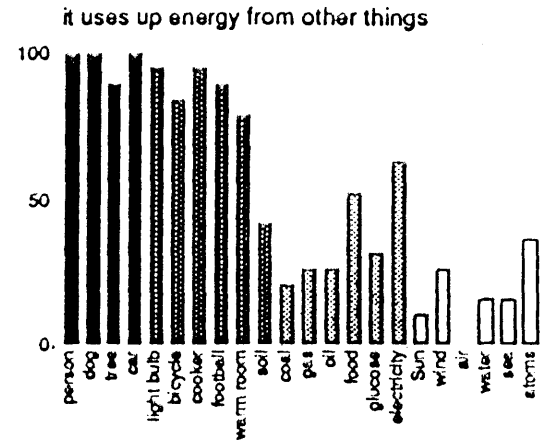
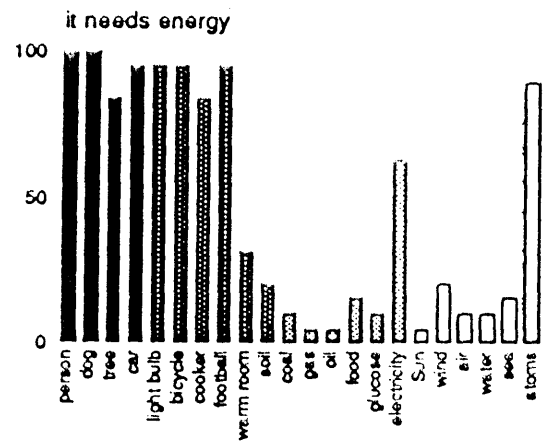

Figure 7.3 Percentages of 'yes' answers for entities: older children

Figures 7.4-8 Percentages of 'yes' answers for entities: older children

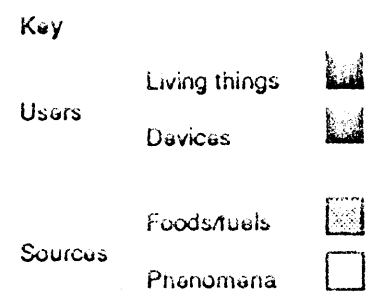
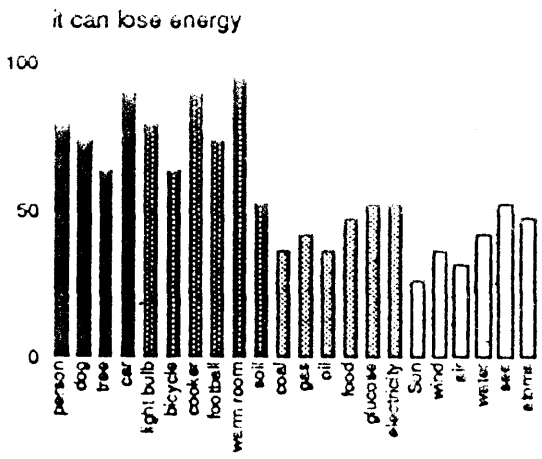
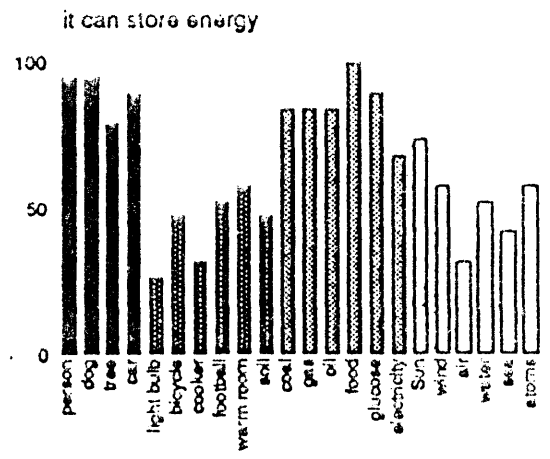
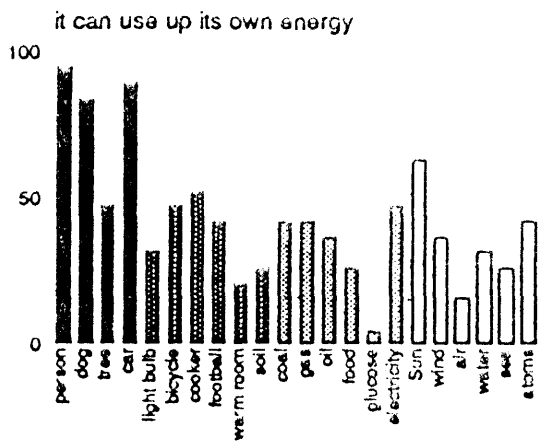

Figure 7.2 Percentages of 'yes' answers for entities: older children (continued)

Figure 7.4-8 Percentages of 'yes' answers for entities; older children (continued)

Comparing the Older Pupils with the Younger Ones

Figures 7.4-4 and 7.4-8, which represent the percentage of YES answers for entities of the younger and older pupils respectively, make it possible to show what differences there are in the way two groups of pupils are thinking. One of the major features of the second dimension for the younger pupils is "Uses up its own energy." For the older pupils Living Things are more often seen as "Using their own energy", but now contribute to the Source/Consumer distinction.

A closer inspection of the difference between the groups reveals some interesting points. Table 7.4 shows the major differences between the two groups.

TABLE 7.4 DIFFERENCES BETWEEN GROUPS		
WAY ENTITY OBSERVED.	YOUNGER PUPILS	OLDER PUPILS
Mechanical objects football, bicycle	Not having energy	Often think they do have energy
Soil	User of energy	Do not see it as a user of energy
Atoms	Source of energy Get energy from	Not a source of energy Need energy Get energy from
Air	Source of energy	Consider it much less as a source of energy

These distinctions between the older and younger pupils suggest that the older pupils may have some idea about mechanical energy as in the case of the football and bicycle. Where

soil is concerned, perhaps the older pupils know more about how plants grow, seeing soil much less a user of energy than the younger pupils. Atoms are interesting in that the older pupils consider atoms as needing energy and less often as something from which we get energy. A similar difference can be seen between fuels and natural phenomena, in that fuels are more often thought of as being energy, whereas natural phenomena are seen less often in this way. Another significant difference is the way electricity is viewed. The older pupils view it as a source and to some degree a user (needs energy, uses up energy from other things), whereas the younger pupils see electricity primarily as a source of energy.

7.4.2 Analysis of Energy Questionnaire Post Teaching

Both sets of pupils were given the energy questionnaire after the six week teaching project. The analysis was the same as for the pre-teaching test.

Analysis of Younger Pupils

Figure 7.4-9 shows the MDS map. It can be seen that the horizontal dimension remains the stronger in dividing the entities into two groups. It is also noticeable that the second dimension almost disappears, with only heat, atoms, soil and electricity weakly contributing to it. The four groups that were present in Figure 7.4-3 distinguishing the entities no longer appear so strongly. There is a trend towards seeing the entities more as Source/Consumer as in the case of the older pupils. (Figure 7.4-7) When the two sets of results (pre/post) were subjected to individual MDS scaling, it was found that the weights of each dimension were considerably different. Table 7.5 shows these weightings.

FIGURE 7.4-9

Multi-dimensional scaling - younger pupils

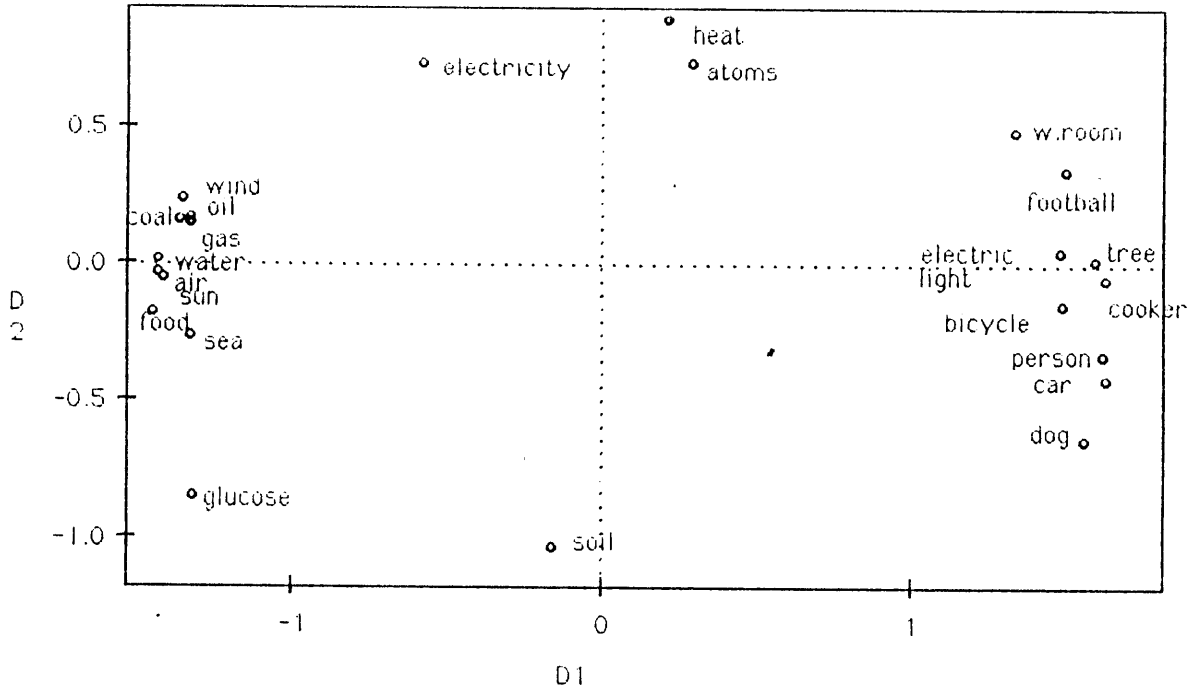

FIGURE 7.4-11

Multi-dimensional scaling - older pupils

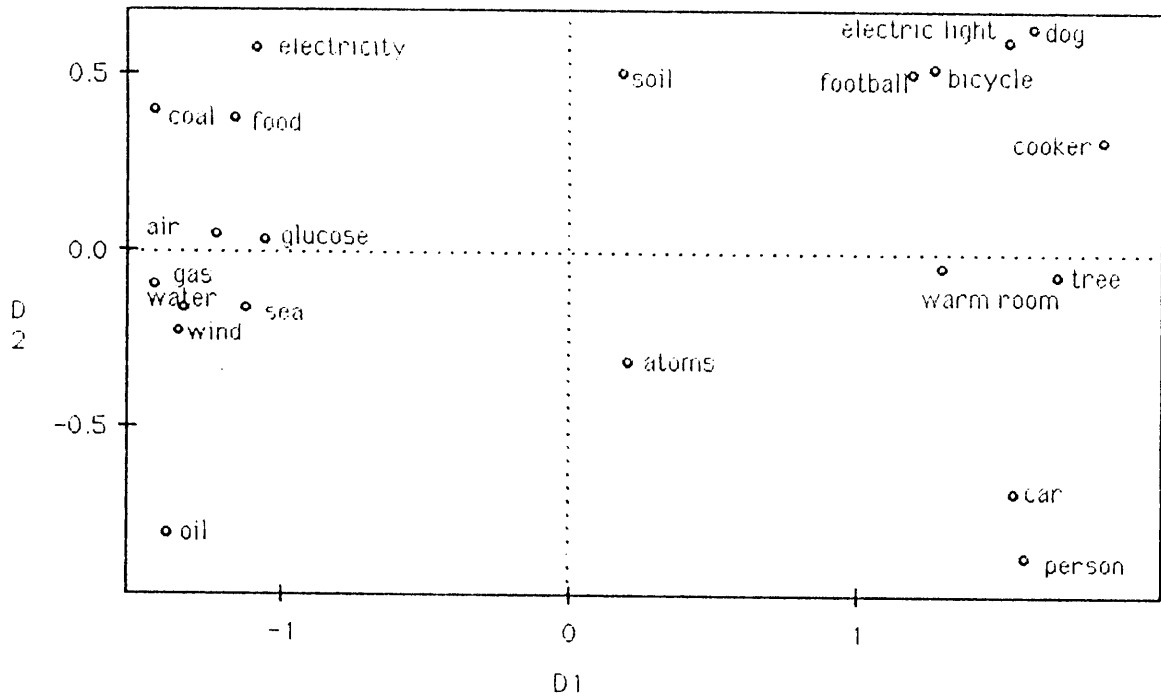

TABLE 7.5 COMPARISON OF WEIGHTING FROM MDS MAP FOR PRE AND POST TEST			
SUBJECT NUMBER	WEIRDNESS	DIMENSIONS	
		1	2
BEFORE 1	0.4093	0.8971	0.2745
AFTER 2	0.8928	0.9783	0.0126

It can be seen that there is a noticeable difference in the "weirdness score" in that after teaching, Dimension 1 scores increase and Dimension 2 scores decrease, suggesting that after teaching pupils give less importance to Dimension 2 and more to Dimension 1. Figure 7.4-10 shows the percentage YES responses for each entity, for three aspects of energy, these being the aspects that differentiated how the pupils viewed energy prior to teaching.

Comparing Figure 7.4-4 with 7.4-10 one can see that much less importance is given to entities losing energy, for example coal, gas, oil, food, electricity, glucose and soil are significantly smaller in value; similarly an important aspect prior to teaching was that of "using up own energy." Comparing the two graphs (Figure 7.4-4 and Figure 7.4-10) it can be seen that certain entities are given more importance after teaching than prior to teaching, these include coal, oil and gas, as well as two unexpected entities (football and cooker). However the natural phenomena are now seen as having less to do with using up their own energy.

A tentative explanation for these results could be that the pupils are now not relating the energy associated with the natural phenomena quite so strongly to their direct action, ie sun shining, wind blowing. It is also interesting to see that less importance is given to storing energy, especially with respect to electricity and atoms. This could be directly attributable to the energy project which introduced the pupils to various forms of domestic heating, and how these forms were manufactured, including the generating of electricity from nuclear fuel.

Percentage yes answers for various items

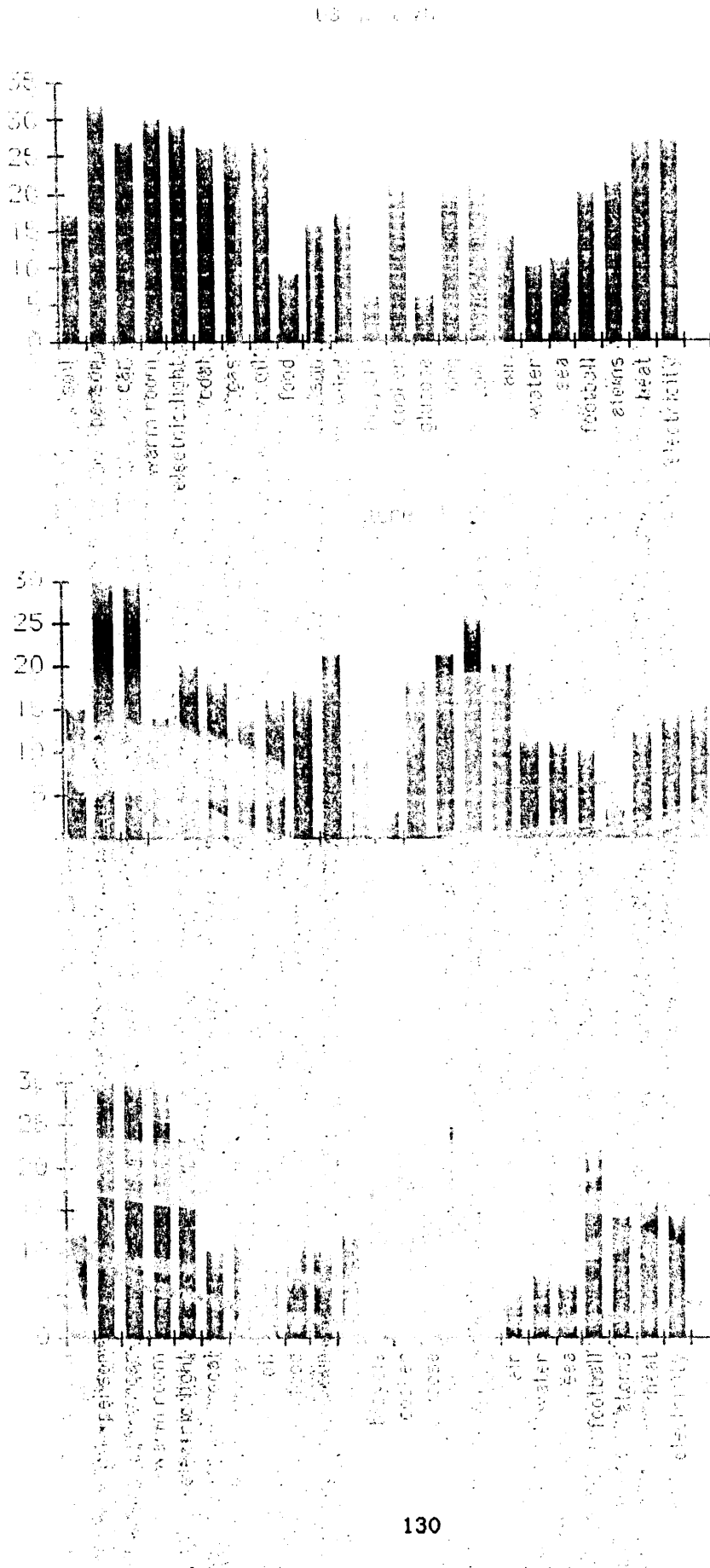

Analysis of Older Pupils Post Teaching

Comparing the MDS maps (Figures 7.4-7 and 7.4-11) before and after teaching, it can be seen that the horizontal dimension is most prominent in dividing the entities, with no real second dimension in evidence. The only contributing entities are soil and atoms in both maps. It would appear that the way the entities are placed on the scaling diagram is because they correlated very weakly with the majority of the other entities and with each other. Figure 7.4-12 shows the percentage YES responses for the three aspects of energy that most distinguished the entities, which are "use up own energy", "storing energy" and "losing energy."

Figure 7.4-12 shows that the older pupils do not see many entities as "using up their own energy", the exceptions being person, dog, car, and the sun, however they do give importance to "storing energy" and "losing energy." Four entities are worthy of further examination, these are light-bulb, cooker, warm room, and glucose. The former two entities appear not to store energy or use their own energy, however both are seen as high in "losing energy." The warm room is seen as "losing energy" and to a certain extent "storing energy", but does not "use its own energy." Glucose rates highly on "storing energy" reasonably highly for "losing energy", and very low at "using its own energy." These points are interesting because they appear to suggest that the older pupils see an exchange of energy in some way, through the "storing" and "losing" of energy.

FIGURE 7.4-12

Percentage yes answers for older pupils

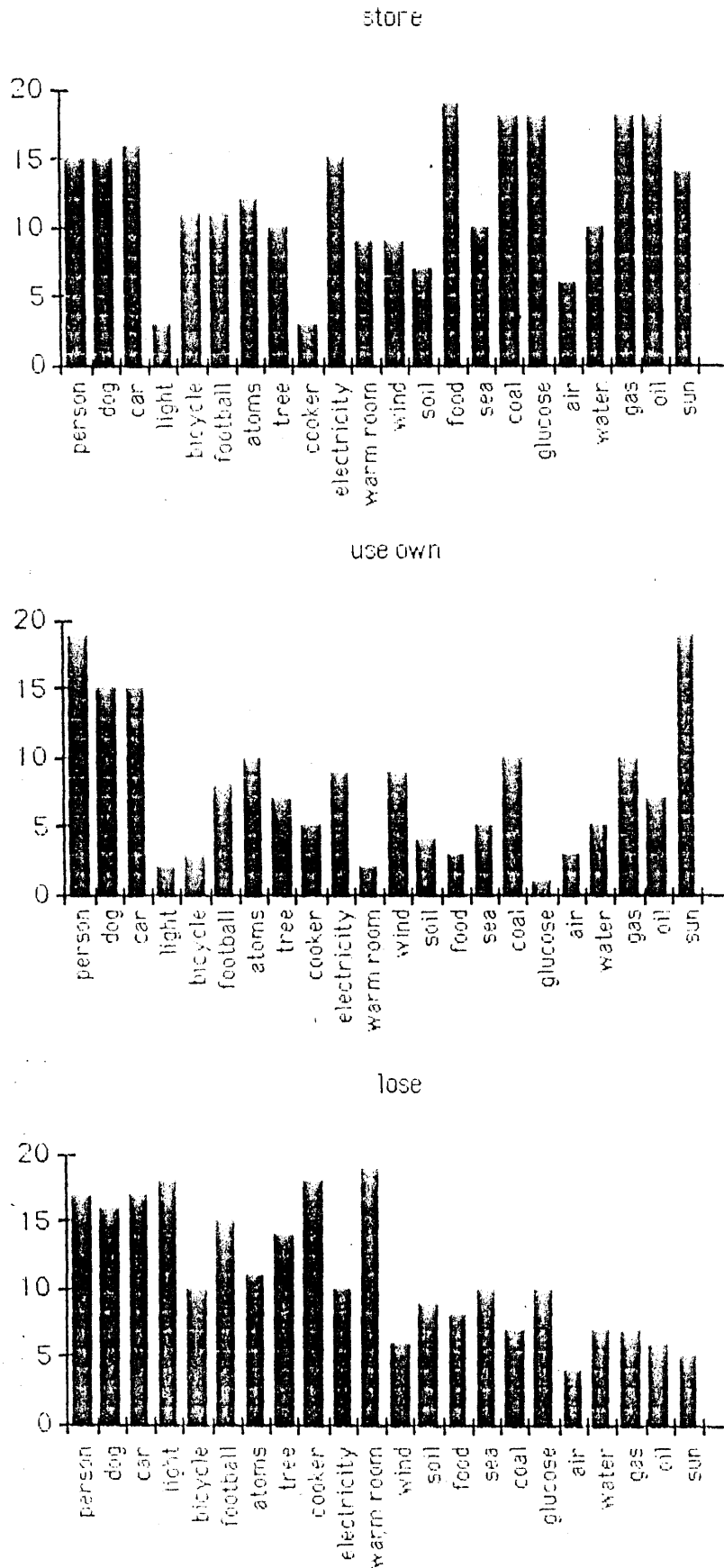

Comparing the Older Pupils with the Younger Ones

The MDS maps (Figure 7.4-9 and 7.4-11) look very similar, indicating that the younger pupils now give more importance to the first dimension of "Source"/"Consumer", and less to the second dimension concerned with "Act on own"/"Used to Act." It is also interesting to note that the entities "atoms" and "soil" appear in the second dimension for both groups.

The percentage YES responses (Figure 7.4-10 and 7.4-12) for the aspect "use up own energy", show that the younger pupils still give more importance to this aspect than the older pupils, however the aspects "store energy" and "lose energy" now appear to be similar for both groups.

7.5 Some Conclusions

The analysis has shown that it is possible to describe underlying structures in the way children of differing ages conceive energy. A major feature has been in detecting a main structure common to both sets of pupils, namely a distinction between Sources and Consumers of Energy.

For both sets of pupils prior to and after teaching, "Sources" as well as being things which give energy are also considered as being energy. This includes foods, fuels and visibly active phenomena such as wind, water, and the sea. However, the younger pupils appear to identify losing energy with losing activity whereas the older pupils see losing energy as being connected with being a "user of energy." After teaching, the younger pupils do appear to show signs of seeing the aspect of "losing energy" more as the older pupils do.

A significant difference between the older and younger pupils is the way in which they view the behaviour of the four groups, Natural Phenomena, Living Things, Energy Using devices and Foods and Fuel. The differentiation of Consumer/Source was found in both; however the younger pupils appeared to distinguish between entities that could "act alone" and those which are "used to act." It is possible that this relationship stems from the younger pupils' view of animacy, in association with energy. A major difference between the two sets of pupils is that the older ones see the connection of energy and activity as less important. Similar signs are apparent for the younger pupils after teaching, whereas the older pupils give almost no connection to the energy-activity equation. It seems that the older pupils view energy as something that can be exchanged between objects, hence indicating that an object can be both a "source" and a "user" of energy.

In conclusion it can be said that the analysis of the questionnaire seems to indicate that the pupils' view of energy does show some signs of changing with teaching. This is especially evident in the younger pupils' work. The evidence is not quite so clear with the older pupils, however there is evidence to suggest that a slight change may have occurred.

The first results of the energy questionnaire were reported in a paper "Dimensions of Childrens' Conceptions of Energy." (Appendix 18).

Chapter 8

DATA ANALYSIS - CSMS TASKS AND ANALYSIS OF CHILDRENS' WORK

8.1 CSMS TASKS

8.1.1 Introduction

Data on pupils' cognitive levels provided information for making judgements on possible teaching strategies. Much of the project work gave insight into the ability of the children. However it was important to see if this was reaffirmed by their cognitive level, and to what extent these classes represented normal classes of 9 to 10 and 11 to 12 year olds. The tests chosen were the Science Reasoning Tasks, the contents of which are described in Chapter 6. The data in this section came from the administration of these tasks given to pupils involved in the project in both Primary schools. These included two classes of 11+ year olds, (class 1a and 1b), and one class of 10+ year olds, (class 3). Unfortunately time and circumstance did not allow pupils in the Secondary school to be tested. These tasks were given to obtain background information relating to the cognitive levels of the classes and of each pupil individually. The following questions need to be considered:

- 1 Do the children of each class respectively match the national norm?
- 2 What kind of evidence of individual cognitive level do the tests show?
- 3 Can the determination of the cognitive levels of the pupils help to predict possible problem areas in the software?

- 4 How well do the pupils perform with respect to the conceptual demands of the software?

If one is to assume that the pupils' written work in the form of project books and the individual tasks completed are an appropriate way of trying to assess their abilities, it is important to compare these assessments with a set of standardised results such as those given by the CSMS tasks. It would then be possible to consider the question:

- 5 To what extent can the written data from the children be used as evidence of understanding difficulties as related to the software's cognitive demands?

8.1.2 Analysis

The Science Reasoning Tasks (SRT) are criterion rather than norm-referenced, in that the Piagetian level of each subject is estimated directly. Using the task scores from each task it was possible to obtain the cognitive level attained by each pupil (Appendix 13). The scores are calculated as follows for both tasks:

"Each item is written to test the performance at a particular Piagetian level

Each pupil scored right (1) or wrong (0). The assessment is made on the total number of items that have been answered correctly.

The level of development is expressed directly as a number on a scale."

(The scale can be seen in Appendix 14)

[Shayer (1989) p4]

Table 8.1-2 shows the number of pupils in each class at each cognitive level for tasks 1 and 2.

Cognitive Level Results

This section will look at the data for:

- (a) The class as a whole;
- (b) Individual assessment.

Class as a whole

The first question posed was:

"Do the children of each class respectively match the national norm?"

The percentage at each cognitive level, for each class were calculated, and compared to the national average, as predicted by the Shayer results, Figure 8.1-1 and Table 8.1-1 in order to answer the above question.

FIGURE 8.1-1

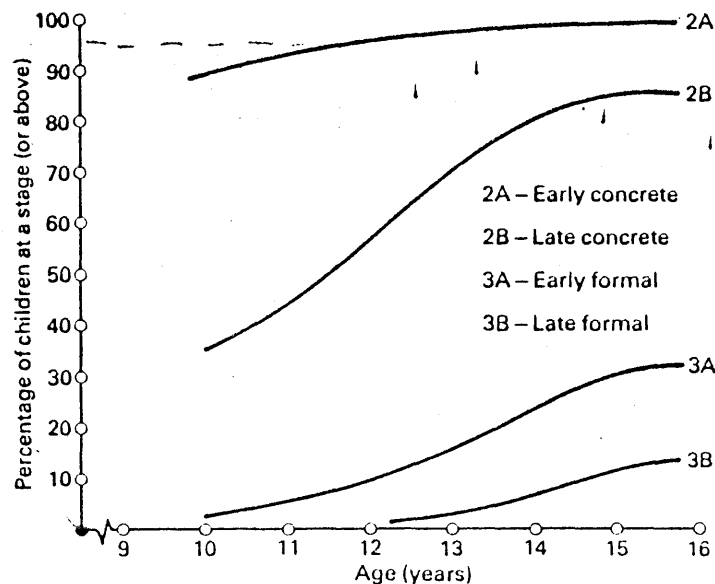

From the Figure 8.1-1 the cumulative percentages of the national average can be found, as shown in Table 8.1-1. Table 8.1-2, gives the cumulative percentages for class 1a, 1b and class 3.

From Table 8.1-1 it can be seen that 90% of pupils aged approximately 10.5 years have reached 2A, and 40% have reached 2B. Examining the numbers for Class 3 (Table 8.1-2), 96% have reached 2A and 46% have reached 2B.

TABLE 8.1-1 SHAYER DATA		TABLE 8.1-2 CLASS 1a, 1b and 3 DATA				
LEVEL	CUMULATIVE % NA (11.5) Years	CUMULATIVE % CLASS 1a (11+)		CLASS 1b (11+)		CSMS TASKS
		Task 2	Task 1	Task 2	Task 1	
2A	95	97 93	94 94	100 82	95 95	2A 2A/2B
2B	50	93 37	75 19	53 24	65 21	2B 2B
3A	10	4	0	9	0	3A
3B	0	-	-	-	-	3B
LEVEL	CUMULATIVE % NA (10.5) Years	CLASS 3 (10+)		CSMS TASKS		
		Task 2	Task 1			
2A	90	100 100	100 96	2A 2A/2B		
2B	40	70 35	46 8	2B 2B+		
3A	5	8	0	3A		
3B	0	-	-	3B		

The figures are slightly but not much higher than the national average. A similar picture can be found for Class 1b. However Class 1a does appear to have a rather higher percentage of pupils reaching 2B than average, though with fewer attaining 3A.

The frequencies of children at levels <2A, 2A, 2B, and 3A were compared with expected frequencies from the national data, Shayer (1979), using a Chi-squared test.

TABLE 8.1-3 CHI-SQUARED TEST FOR CLASSES 1a, 1b and 3 Class 1a				
LEVEL	NATIONAL CUMULATIVE %	% IN EACH CLASS	PREDICTED NUMBER FOR CLASS OF 26	ACTUAL NUMBER IN CLASS
<2A	100	5	1.3	0
2A	95	45	11.7	6
2B	50	40	10.4	19
3A	10	10	2.6	1
3B	0	0	0	0
LEVEL	OBSERVED NUMBER	EXPECTED NUMBER	(OBS - EXP)	$\frac{(OBS - EXP)^2}{EXP}$
<2A	0	1.3	-1.3	1.3
2A	6	11.7	-5.7	2.7
2B	19	10.4	8.6	7.1
3A	1	2.6	-1.6	1.0
TOTAL = 12.1				

$X^2 = 12.1$, 3df, significant at $p < 0.001$

Class 1b				
LEVEL	NATIONAL CUMULATIVE %	% IN EACH CLASS	PREDICTED NUMBER FOR CLASS OF 37	ACTUAL NUMBER IN CLASS
<2A	100	5	1.9	0
2A	95	45	16.6	17
2B	50	40	14.8	17
3A	10	10	3.7	3
LEVEL	OBSERVED NUMBER	EXPECTED NUMBER	(OBS - EXP)	$\frac{(OBS - EXP)^2}{EXP}$
<2A	0	1.9	-1.9	1.9
2A	17	16.6	0.4	0.010
2B	17	14.8	2.2	0.300
3A	3	3.7	-0.7	0.100
TOTAL = 2.310				

$X^2 = 2.310, 3df, \text{ not significant } (p = 0.5)$

Class 3				
LEVEL	NATIONAL CUMULATIVE %	% IN EACH CLASS	PREDICTED NUMBER FOR CLASS OF 26	ACTUAL NUMBER IN CLASS
<2A	100	10	2.6	0
2A	90	50	13.0	14
2B	40	35	10.4	12
3A	5	5	1.3	0
LEVEL	OBSERVED NUMBER	EXPECTED NUMBER	(OBS - EXP)	$\frac{(OBS - EXP)^2}{EXP}$
<2A	0	2.6	-2.6	2.60
2A	14	13.0	1.0	0.08
2B	12	10.4	1.6	0.25
3A	0	1.3	-1.3	1.30
TOTAL = 4.23				

$X^2 = 4.23$, 3df, not significant, ($p = 0.25$)

The Chi-squared tests indicate that there is no reason to reject the hypothesis that the frequencies fit the national data, for classes 1b and 3. Class 1a however had more pupils than expected at level 2B, and fewer at lower levels. The departure from the national norm, is statistically significant, ($X^2 = 12.1$, $p = <0.01$, 3df). The school reported that this class had been notably high-achieving, compared with their normal expectations, in agreement with the above result.

The effect is an excess of pupils at level 2B and fewer at 2A, but not of any excess at level 3A. This may be expected to have some impact on their results, but not as much as if there had been substantial extra numbers, at level 3A, where formal operations are just beginning. This slightly unusual level of development in the class as a whole will be taken into account in giving interpretations of their work in Chapter 8, section 8.3 and 8.4, and Chapter 9.

8.1.3 Looking at the SRTs Alone

In order to consider the second question:

"What kind of evidence of individual cognitive level does the test show?"

It is necessary to look at the SRT results and compare them with what pupils of 10+ and 11+ would be expected to be able to do. This is done by considering the Curriculum Analysis Taxonomy, Tables 8.1-4, 8.1-5 and 8.1-6. These give information as to the nature of relevant work pupils could be expected to achieve. Secondly, a closer examination of individual cases will be looked at to find major differences in cognitive level, in an attempt to "predict" possible difficulties.

In principle, it is also possible to use the Curriculum Analysis Taxonomy to rate the levels of difficulty of various activities required by the software. The first taxonomy concentrates on the mental activities

of pupils and the second on the intellectual elements or schemas specific to different types of science activities. (The complete Taxonomy can be seen in Appendix 15).

8.1.4 General Expected Level of Achievement Based on SRTs

Table 8.1-2 shows the cumulative percentage of each class with respect to Piagetian levels. This will be used as a guide to what each class should be able to achieve:

- (a) With respect to energy concepts;
- (b) With respect to the conceptual demands of the software.

Table 8.1-4

Function	1 pre-operational	2A early concrete	2B late concrete	3A early formal	3B late formal
1.1 Interest and Investigation style	Things are believed to be exactly as they appear to immediate perception. Perception dictates decisions. Faced with a mature person's ideas of evidence, will deny it, explain it anthropomorphically, or be silent. Does not perceive contradictions.	Will register what happens, but for interest to be maintained after the first obvious observations needs a associative or simple associative model ⁴ . Unaided investigation style does not go as far as producing concrete models. (see 1.4-2A and 2B)	Will include variation ¹ and classification ² as tools of perception in finding out what happens, but needs to be provided with a concrete model by which to structure experimental results (classes must be given, and examples of the application shown). Finds interest in making and checking cause-and-effect predictions.	Finds further interest in beginning to look for why, and following out consequences from a formal model. Confused by the request to investigate empirical relationships without an interpretative model. Can use a formal model, (see 1.4-3A) but requires it to be provided. Can generate concrete models with interest. Can see the point of making hypotheses, and can plan simple controlled experiments, but is likely to need help in deducing relationships from results and in organising the information so that irrelevant variables are excluded at each step.	Finds interest in generating and checking possible 'why' explanations. Will tolerate absence of an interpretative model while investigating empirical relationships. Takes it as obvious that in a system with several variables he must 'hold all other things equal' while varying one at a time, and can plan such investigations and interpret results. Will make quantitative checks involving proportionality relationships.
1.2 Reasons for events	Interprets phenomena egocentrically, in terms of his own self.	See 1.1, 1.3, and 1.4: 'Cause-and-effect only partly structured—'this goes with that'; so uses associative reasoning. Simple one-factor causes, such as 'force', etc.	Bipolar concepts such as 'alkali destroys acid'. Can use ordering relationships to partially quantify associative relationships: 'as this goes up, that goes down'; 'if you double this you must double that', i.e. 'the reason' involves describing the relationship or categories, not providing a formal model. Cause-and-effect structured according to general concrete stage schemas as 'adding acid makes the pH lower'.	Looks for some causative necessity behind a relation established with concrete schemas. Allows for the possibility of a cause that is not in 1:1 correspondence with observations. Can consider the possibility of multiple causes for one effect, or multiple effects of one cause. Can suspend judgement and allow results of controlled experiments to constrain choice among various cause-and-effect explanations. Can handle formal models as explanatory provided their structure is simple (see 1.4).	Because aware of multiple causes and effects can think of reality in a multivariate way, so can make a general or abstract formulation of a relationship which covers all cases in an economical way. Can use deduction from the properties of a formal model—either from its mathematical or internal physical structure—to make explanatory predictions about reality.
1.3 Relationships	Cannot consistently arrange data in an ordered series.	Can order a series, but is unlikely to see that as an obvious way of summing up observations. Nominal scale ³ relationships—'same distance—same weight' (See-5a v).	Can multiply series, and hence can find 1:1 correspondences between two sets of readings (e.g. weights and extensions of springs), and hence any linear relationship. Readily uses the notion of reversibility. Will use compensation argument to explain a conservation where only ONE variable is independent, e.g. of a piece of clay 'you've made it longer, but it's thinner so it's the same'. See also 2.2.	Uses compensation relationships between TWO independent variables, e.g. weights and distances on both arms of a balance can be changed while preserving equilibrium; resistance is related to both area and length, in electricity. See also 2.2. Simple functional relationships beyond linear, and thus accelerated version of the concrete modelling described in 1.4(2B), rather than formal modelling.)	Can reflect upon reciprocal relationship between several variables. Thus can handle quantitative 'relations between relations' as in proportions, or semi-quantitative relationships as in chemical equilibria. This level of thinking is often needed for analysing experimental results so as to order them for lower-level computation, e.g. weight changes in reactions involving different elements and compounds, or density calculations where density is an inferred concept (density of gases, or Archimedes' problems). See 2.4-3B.

¹ Seriation: putting objects or data into order according to a property such as length, mass (ordinal scales).
² Classification: putting things in groups according to common property.
³ Nominal Scale: scale with two values only: 'Four legs good; two legs bad'.
⁴ Association: co-incidence in time or place serving as basis for prediction.

Type of problem	2A early concrete	2B late concrete	3A early formal	3B late formal
2.5 Control of variables	Can reject a proposed experimental test where a factor whose effect is intuitively obvious is un-controlled, at the level of 'that's not fair', but fails to separate variables and so eliminate one. 'Fairness' may also be applied in the sense of giving every factor an equal chance, e.g. 'Slower runner should be given shorter distance'.	Will usually vary more than one factor in each experiment, and often varies other factors to test the effect of a given one.	Sees the need to vary one factor at a time and can suggest experimental tests to control for factors explicitly named. May fail to control factors that are not perceptually obvious. Fails to develop a strategy based on a feeling of the system as a whole. May not see the point of having an experiment without a factor present to see if it is a variable.	Sets up suitable experiments to economically control factors and eliminate ones that are not effective, and can apply 'all other things equal' strategy to multivariable problems. More sophisticated biological experiments possible including interaction effects. Appreciates the impossibility of controlling natural variation, and so the need for proper sampling.
2.3 Equilibria of systems	See 1.3-2A. Observations ordered in terms of one property.	Relationships between variables only conceptualised two at a time, with the relationship linear (direct or inverse). (Single variables like force not compound variables such as pressure.)	Where there are two independent variables related to each other at equilibrium, will discover this relationship, provided the ratios are simple whole numbers e.g. 3/2; 1/4; 3/4, etc. e.g. $W_1/W_2 = L_2/L_1$ in a balance, or $A_1/h_2 = a_2/a_1$ in hydraulic press, without grasping the internal law of the whole system.	Can compare any ratio in two independent variables' equilibria by treating them as a proportion. When there are 3 or more variables related to each other at equilibrium, can conceptualise the relationship of the third to the other two, and thus arrive at a general law for the system, and can discuss the reciprocal relation of the first two variables e.g. in the case of the inclined plane relates the track weight and hanging weight variables by equating them to the ratio of the vertical rises and fall of each. Can provide an explanation for a relation established at 3A level, e.g. $A_1/h_2 = a_2/a_1$, because pressure produced by each arm is the same—leading to view of the whole system.
2.4 Mathematical Operations	Number is now distinguished effectively from size, shape, appearance. Number as a series, but confined to the numbers which can be given a conceivable concrete realisation.	Can work with single operations (e.g. addition, subtraction, division and multiplication) but the system of numbers must have closure, i.e. the operation must be unambiguous and the result of the operation must be within the set, e.g. $5 + 4 = x$ can be solved, but $7 - 7 = 3$ or $5 \div 4$ cannot.	Concrete generalisation. Can work with the relationship $V = bh$ or $W_1/H_1 = W_2/H_2$ but only by treating each step as a definite operation on definite numbers. Begins to accept lack of closure, e.g. can solve $7 - 7 = 7 - 3$ by a series of operations to each side of the relation.	Can properly conceive of a variable, and begins to work with the explicit rules of a system so as to develop proof strategies. See 1.3-3B. Rather than needing a formula where several variables are involved, can analyse the set of relations required by the model so as to sequence correctly a series of simple computations e.g. with a 'hydrogen-oxygen' model realises the weight changes relating to H and O separately must be computed before weights of other compounds can be computed. Before a density calculation can be set up the relevant weight and volume changes must be found.
2.6 Correlations/Reasoning	Number is now distinguished effectively from size, shape, appearance. Number as a series, but confined to the numbers which can be given a conceivable concrete realisation.	No systematic method of examining the strength of a relationship except to look to see if the confirming cases are bigger in number than all the rest.	Begins to look at the ratio of confirming to disconfirming cases, but tends to look only at the probability of two of the four cases, e.g. for blue or brown eyes and light or dark hair will compare the ratio of those with blue eyes and blond hair to those with blue and dark.	Realises that the opposite pairs are as important as each other. Thus takes the brown eyes/dark hair set together with the blue eyes/fair hair set, and compares it with the sum of the two disconfirming cases (brown/fair and blue/dark).
2.9 Measurement Skills	Makes measurements by comparing beginning and ending of object/journey with rule in simple whole numbers.	Bar diagrams, histograms, idea of mean as the centre of a histogram, and variation as its breadth. Graphical relationships of first order equations. Interpretation of graphs where there is a 1:1 correspondence with the object modelled, e.g. height/time relationship for the growth of a plant.	Interpretation of higher order graphical relations in terms of rates (instantaneous slopes) and reciprocal relationships; conceptualisation of relationships between variables, e.g. in $V = bh$, if V constant, b and/or h must drop proportionally.	Interpretation of higher order graphical relations in terms of rates (instantaneous slopes) and reciprocal relationships; conceptualisation of relationships between variables, e.g. in $V = bh$, if V constant, b and/or h must drop proportionally.

Topic	2A early concrete	2B late concrete	3A early formal	3B late formal
P.6 Newton's Laws	See P4, P5 and P2.	See P4, P5, and P2.	See P.4 for First Law. Where accelerations are constant can handle Second Law as a relationship between Force, Mass, and Acceleration. Unlikely to grasp the necessity for the Third Law, but can see the sense of it when confronted with experimental evidence.	See P.4 for First Law. Can analyse problems to see how to apply the first two Laws, and plan sequence of computations. Since he tends to think in terms of proof strategies can eventually see (from many examples) the necessity for the Third Law, and will treat all three as a set of axioms which produces consistent results.
P.7 Electricity	Bulbs light when connected to batteries. A bright bulb has more energy than a dim bulb. Likely to internalise a 'box connection' model of electricity flow. No potential/current distribution.	Can use voltage as a global measure of electrical forces. Although readings on an ammeter are used, as a measure of electricity, concept of current tends to be collapsed under voltage, so effects of current are given a 'voltage' explanation.	Notion of resistance as V/I ratio. Can use a fluid model of current flow and predict with it properties of circuits, e.g. where direction of some of the batteries are changed, or where series is changed to parallel. Draws circuits in terms of a consistent two-current model—e.g. will realise that a light-bulb must have a second connecting point for the filament.	Potential as an intensive property is distinguished from the extensive property of electricity, and hence potential as work required to transfer charge between two points. Potential drop in different parts of a complex circuit may be modelled (will needs to be taught well!).
P.8 Temperature and Heat	No distinction between heat and temperature. Temperature as a qualitative concept of hotness and coldness.	Temperature quite well conceptualised as linear 1:1 mapping of the number line on to 'degree of hotness'. Amount of heat only imperfectly conceptualised—usually collapsed under temperature. Amount of heat depends on mass of hot substance.	Caloric model of heat/temperature relationship, and calculations involved. Kinetic theory picture accepted as providing explanation of particular phenomena, but not integrated with heat/temperature model.	Can use kinetic theory as predictive and explanatory model. Therefore can begin to appreciate the First Law of thermodynamics, and can deal with thermal equilibria as dynamic and statistical.
P.9 Kinetic Theory	See Text. 1.4. In no way is kinetic theory concrete modelling	Used to explain only phenomena in simple correspondence with model. e.g. expansion due to greater vibration of particles, so particles expand or take up more space. Solution seen as intermingling of particles, so volume of solute is conserved.	Can appreciate its use as a deductive model proceeding from simple postulates. Relative properties of gases, liquids, and solids explained. Relative diffusion rates of different gases, and of gases into a vacuum compared with into air. Ready to appreciate quantitative derivation of gas laws and to conceive of temperature as only the mean value of a wide range of kinetic energies.	Can appreciate its use as a deductive model proceeding from simple postulates. Relative properties of gases, liquids, and solids explained. Relative diffusion rates of different gases, and of gases into a vacuum compared with into air. Ready to appreciate quantitative derivation of gas laws and to conceive of temperature as only the mean value of a wide range of kinetic energies.
P.10 Energy and Power	Work is expended energy. Energy has many sources. Power can be differentiated from work. All three concepts are intuitive and anthropomorphic	Work is expended energy. Energy has many sources. Power can be differentiated from work. All three concepts are intuitive and anthropomorphic	Work as a Force x Distance product. Kinetic energy as defined as $\frac{1}{2}mv^2$ —hence deduction about stopping distances of cars from different speeds. Electric energy as $V \times I \times t$ product. Power as work done in unit time. Heat energy as calories.	Equivalence of different energy forms having each a capacity (extensive) and a potential (intensive) aspect. Energy as a general product of extensive and intensive factor. Can begin to appreciate the problem of Heat as a form of energy is only partly convertible to work.
P.11 Thermodynamics		Conservation of energy as a learnt concept. Mechanical equivalent of Heat as a learnt fact.	Conservation of energy as a learnt concept. Mechanical equivalent of Heat as a learnt fact.	Capable of seeing $dE = W - q$ as a postulate which connects measured quantities to a formal model which, like Newton's Laws, appears to yield consistent predictions. Thus can eventually see that Heat, as a form of energy, needs a second postulate to connect it with other forms of energy.
P.12 Light	Can use a linear propagation (straight line) model to 'explain' reflection of seen rays from a flat mirror. 'The smaller the angle it goes in, the smaller the angle it goes out.' Shadows larger the nearer the object is to the light.	Can use the Lens Laws to deal with real images (linear propagation model) but as algorithm. Uncomfortable with wave model as phenomenon of light too obliquely connected with properties of model. Wavelength/frequency relationship as a computational algorithm. Light as part of electromagnetic spectrum.	Can use wave model to account qualitatively for diffraction/interference phenomena. Can see Lens Laws as a deductive system and can learn to compute within their rules. Transverse and Longitudinal waves and velocity of transmission relating wavelength and frequency. Em spectrum and frequency of waves related to properties of emitting resonator.	Can use wave model to account qualitatively for diffraction/interference phenomena. Can see Lens Laws as a deductive system and can learn to compute within their rules. Transverse and Longitudinal waves and velocity of transmission relating wavelength and frequency. Em spectrum and frequency of waves related to properties of emitting resonator.

ENERGY CONCEPT

Class 3

Ninety-six per cent of the class are at 2A/2B with approximately 50% at 2B. From sections P8 to P11, in Table 8.1-6 it can be seen that most concepts relating to energy require a minimum level of 2B, and areas of conservation of energy require 3A. From this, one would anticipate pupils in this class having problems grasping the fundamentals of energy conservation, and differentiating power and work.

Class 1a

On average 84% of this class are at 2B with 4% having reached 3A. This indicates that the majority of the class should be able to deal with simple aspects of energy, such as energy having many sources, and work being expended energy. (Table 8.1-6, sections P8, 9 and 10). However, one would also anticipate a greater proportion of pupils showing some form of understanding of the conservation of energy.

Class 1b

On average 59% of this class have attained level 2B with 9% having reached 3A. One would expect a fair proportion of the class to be able to attempt simple energy aspects as indicated above, but fewer showing an understanding of energy conservation.

Demands Made by Software

For the program to run, measurement skills, investigation and data collection skills, and mathematical operations are required. These include working with volumes, area, estimations of length, the collecting and tabulation of data in an ordered way. Minimum levels for these types of tasks, as can be seen in Table 8.1-6 are 2A/2B. The more difficult elements such as seriation, ratios, graphical representations and interpretations, reasons for events and relationships, require a minimum level of 2B/3A.

Class 3

From these assertions it might be expected that Class 3 should be able to collect the relevant data for the program, but would have difficulty in calculating and tabulating prior to entering the information into the database. It would also seem probable that the majority of pupils would not be able to interpret the results from the program, which are given graphically, in a meaningful way.

Class 1a

These pupils having higher than average Piagetian levels should be able to complete the data collection and enter the relevant information into the database. The expected problem areas would be calculation of ratios, and interpretation of graphical information as these require 3A level thinking, which only 4% of the class reached.

Class 1b

The majority of pupils in this class have the Piagetian level expected for their age, and should be able to complete the data collection, but with possible difficulties in terms of area and volume. As with Class 1a the expected problem areas would be those requiring higher level thinking and reasoning.

8.1.5 Individual Differences

Two pupils have been selected to illustrate the two extremes of cognitive level, with reference to two tasks; one related to mathematical concepts, and one with respect to energy. This will be used to illustrate the possible value of using Piagetian levels as a guide to identifying problem areas. In section 8.3 a more detailed look at the pupils' work will give indications as to whether the cognitive levels are reflected in their work.

Class 1(a and b)

Sarah (Assessed as high ability by teacher, Piagetian level = 3A).

Trevor (Assessed by teacher as average to below average, Piagetian level = 2A/2B).

Task 1

The aim of this task was to see how pupils could cope with various mathematical concepts. CEDRIC 2.1 was the main instrument in the investigation. It was hoped that it would reveal the extent to which the pupils understood the data CEDRIC gave back to them. Having fed in the relevant input data, the following set of results were obtained.

TABLE 8.1-7				
USES	KWH	%	COST (£)	%
HEATING	15307.0	75.5	393.4	59.7
COOKING	1560.0	7.7	81.7	12.4
LIGHTING	1280.0	6.3	76.1	10.2
OTHER	2230.0	10.9	116.9	17.7
TOTAL	20377.0		659.1	

The pupils were then asked a series of questions relating to the data.

Question 1

"What does it mean when it says 59.7% is spent on heating?"

Looking at the Curriculum Analysis Taxonomy, (sections 1.1 to 1.3, and 2.3 to 2.9), it can be seen that this type of question requires a minimum of 2B/3A reasoning. If this is compared to the types of answers given by the two pupils, it might be possible to assess how accurately the taxonomy predicts the problem areas.

Sarah

"It means that 59.7p of every pound spent on energy in the house is spent on heating."

Trevor

"This means that the certain percentage out of a hundred is spent on heating."

Question 2

"What does it mean when it says 20% of all heat is lost through the roof of a house?"

Sarah

"Of all the heat lost in an average house, 20% or a fifth is lost through the roof."

Trevor

"It means that 20% of the heat is lost through the roof."

These replies confirm that Sarah is working at 2B/3A. She appears to have no difficulty in defining percentages and manipulating ratios, on the other hand Trevor does not explain anything. He at best repeats the question,

perhaps indicative of the difficulties encountered by someone capable of 2A/2B reasoning.

Task 2

The pupils were asked to define energy and to discuss some of its sources and uses, (see section 8.2). Here two examples are again chosen to illustrate the possibility of using the Curriculum Analysis Taxonomy for predicting problem areas. The aspect of energy to be considered is that of energy and power. From the taxonomy, Table 8.1-6 a minimum level of 2B is needed for the realisation that:

- 1 Work is expended energy;
- 2 Energy has many sources;
- 3 Power can be differentiated from work.

At this level all three concepts are intuitive and anthropomorphic.

Sarah's Work 3A

"Energy is used by many forms of equipment and machinery wherever we look. The human body uses great amounts of energy when performing its daily tasks, and for warming itself against cold. All types of engines use energy including motor vehicles, aeroplanes, ships and trains all types of heating use energy to produce their heat."

"Energy is power."

Trevor's Work 2A/2B

"I think that we can see energy through people riding, jogging, swimming, and talking. But what also amazed me was, that when you are asleep you are using energy. Energy is a thing we need to value otherwise we would be 'dead' Humans run on food that is our power source."

These replies seem to indicate that the children are working within their predicted levels. In Sarah's case, she sees energy as having many forms, that work is expended energy, and a possible connection between heat and energy. However there is no evidence that she can differentiate work and power as a concept. This is all indicative of 2B/3A reasoning.

Trevor gives little indication of energy having many forms and appears to see energy as very much related with living and with humans, and also identifies energy with power, indicative of 2A/2B reasoning.

8.1.6 Discussion of Outcomes from SRTs

The Test Alone

Analysis of the SRTs did give useful information about individual pupils. It identified the highest and lowest cognitive levels in the classes, and helped to distinguish areas of thinking between levels. It also appears to "predict" the areas pupils could find problematic in the software.

Using Piagetian Levels to "Predict" Areas of Difficulty

For the class as a whole the Piagetian levels predicted that certain areas such as ratio, conservation of energy, and the distinction between power and work, would be problematic. On an individual basis the predictions could be useful, as with the case of Sarah and Trevor. Further examination is required to assess more generally (cf section 8.3) if the predictions are helpful for the class as a whole. The table below gives a simple indication as to the degree of difficulty encountered by pupils within respective cognitive levels, when attempting some of the tasks set.

TABLE 8.1-8 SHOWS DEGREE OF DIFFICULTY FOUND					
PIAGETIAN LEVEL	CLASS	RATIO	CONSERVATION	TOPIC POWER/WORK	MATHEMATICAL INTERPRETATION
HIGHER	1a	Little	Some	Some	Little
2B+ to	1b	Some	Considerable	Considerable	Little
3A	3	Some	Considerable	Considerable	Some
LOWER	1a	Some	Considerable	Considerable	Some
2A to	1b	Considerable	Considerable	Considerable	Considerable
2A/2b	3	Considerable	Considerable	Considerable	Considerable

The work of all children in each of the above topics was examined for understanding, interpretation and skill in answering the questions set in the task. If more than 50% of the questions were completed successfully the pupils were recorded as having little difficulty with the question, 50% to 25% some difficulty and <25% considerable difficulty.

Two examples are given below to illustrate the point:

Mum spends £145 on gas. She saved £290 for the gas bill.
What percentage did she spend of it?

Sarah: High Ability (3A)

$$\begin{array}{r} 1 \quad \cancel{145} \quad 100 \quad 100 \\ \quad \quad \times \quad \quad = \quad \quad = 50\% \\ 2 \quad \cancel{290} \quad 1 \quad 2 \end{array}$$

This means she spent half of her money.
Little difficulty.

Trevor: Average/Below Average Ability (2A/2B)

$$145 - 290 = 145 \quad \text{Saved } \pounds 145$$

Considerable difficulty.

These results would be expected from the Curriculum Taxonomy considering the level of cognition that each of the pupils are at respectively.

8.2 ANALYSIS OF CHILDREN'S WORK

8.2.1 Introduction

The data in this section comes from the work completed by the pupils during the six week energy project.

The analysis of the data is directed by three questions:

- 1 To what extent does the pupil's work reflect their ideas and conceptions of energy?
- 2 Does the work reflect their cognitive levels?

If one is to assume that the energy questionnaire gives a picture of the children's conceptions, and that the CSMS tasks identify possible areas of difficulty, the question to be considered is:

- 3 To what extent does the work help us to understand any relations between the CSMS tasks and the energy questionnaire?

8.2.2 Rationale

The energy questionnaire discussed in section 7.2 gave a structure for the way pupils were thinking about energy. However the questionnaire could not give a complete picture, as the answers required no explanation. The analysis of the project work will give further information for making judgements on how the pupils conceptualize energy.

8.2.3 Analysis

The analysis will be in two sections, one dealing with the pupils' written project books, and the other with set tasks, directly related to the software.

Analysis of Work Through a Systemic Network

A systemic network (Bliss, Ogborn, Monk 1983) will be used to describe the structure of pupils' thinking about energy. The network is to be evaluated at two levels:

- 1 Does the network capture interesting features of the pupils' knowledge of energy?
- 2 Do these examples work with respect to the data on individual children?

Designing the Network

The network was developed in order to code the pupils' ideas of energy as portrayed in their class work. Each child had to follow a specific plan for the project, based on the following four questions:

- 1 What is energy?
- 2 How do we use energy?
- 3 What uses energy?
- 4 What are the sources of energy?

These indicate the structure of the content of the work, and how and what they chose to describe and identify. The initial construction of the network was based on the above description and definitions.

Each of the pupils' scripts was examined for evidence from the above four questions and systematically listed into categories as shown in figure 8.2-1. This was a simple first attempt at representing the pupil's ideas.

FIGURE 8.2-1 FIRST ATTEMPT OF ENERGY NETWORK

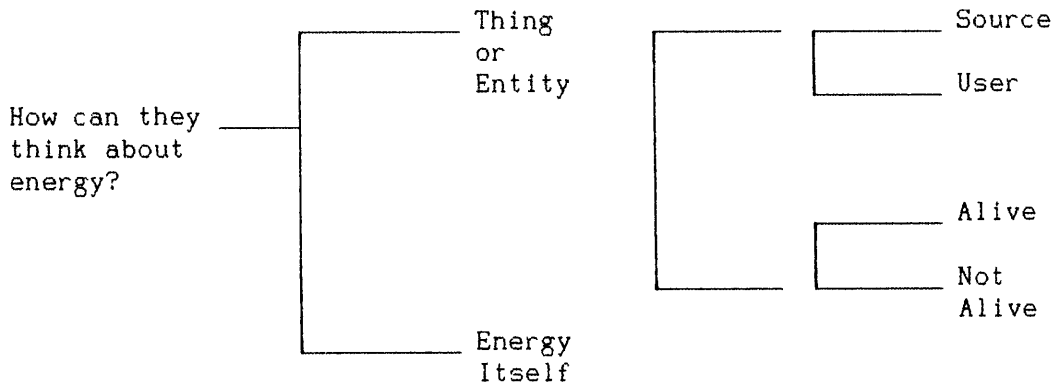

It shows some very simple notions of energy, but does not represent all aspects of the data collected from the pupils. A more detailed description is required, showing possible interactions between the entities, as in Figure 8.2-2.

FIGURE 8.2-2 POSSIBLE INTERACTION OF ENTITIES

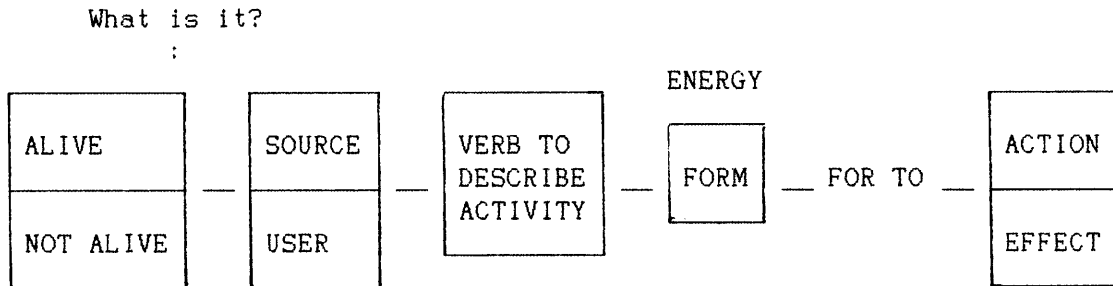

From this a revised version of the network was obtained, Figure 8.2-3. Further expansion of the network then allowed for greater flexibility in coping with the many and varied entities supplied by the pupils. It shows the main ways in which pupils view energy. It also enables a quantity of qualitative data to be represented in a structured account of many individual pieces of work.

FIGURE 8.2-3 FINAL VERSION OF ENERGY NETWORK

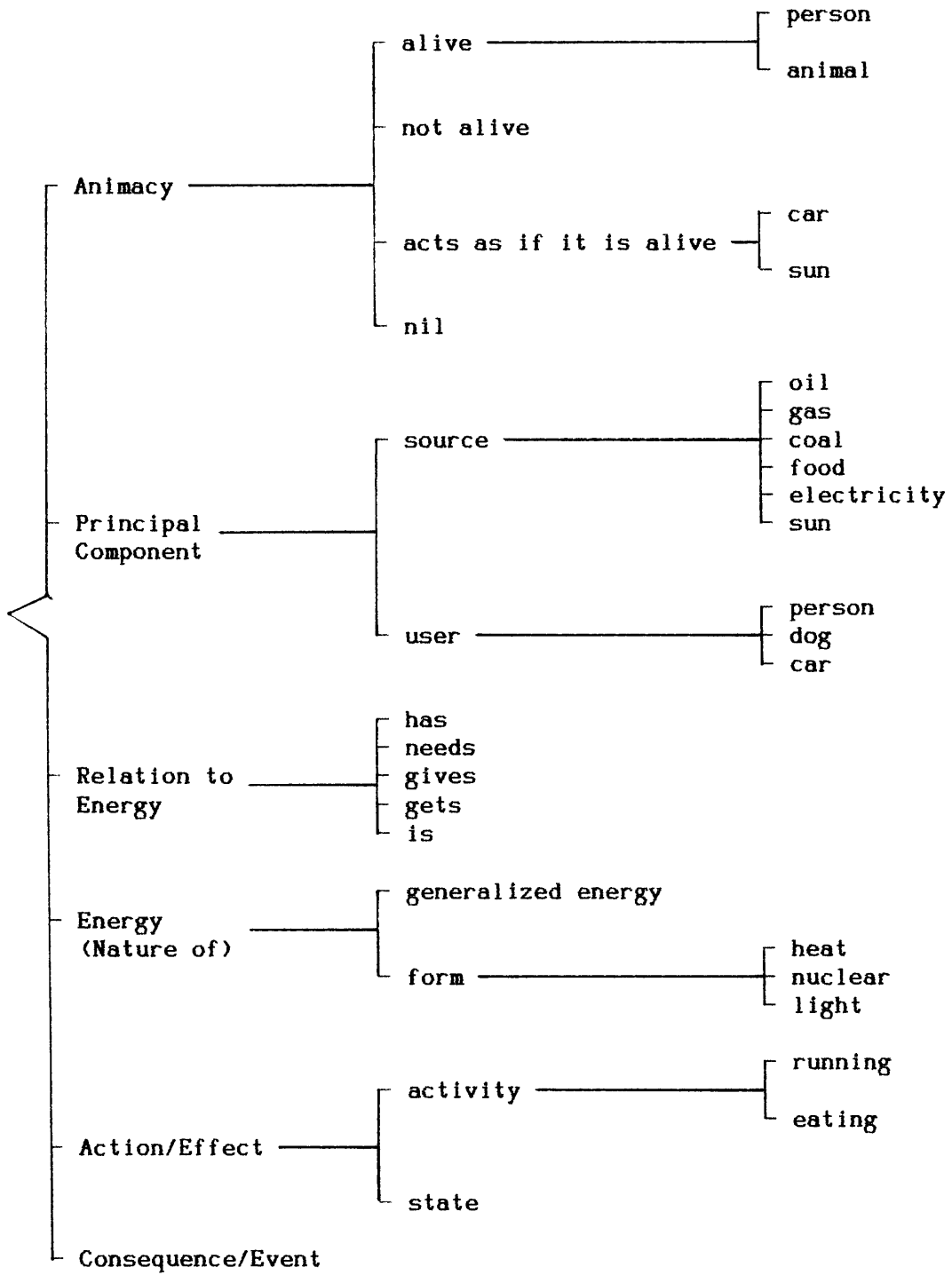

In order to answer the two questions originally posed for evaluating the network, ten pupils' work was considered.

- 1 Does the network capture interesting features of the pupil's knowledge of energy?
- 2 Do these features work with respect to the data collected on individual children?

Examples of work from six pupils from both class 1a and 1b, and four pupils from class 3 will illustrate the usefulness of the network. The pupils were chosen to reflect the full range of abilities.

Class 1a and 1b

The first three pupils are of higher ability, and the second three average to below average ability.

Sarah

"All types of engines use energy including motor bikes, cars and planes, to go."

This fits the network as follows: not alive, user (car), verb (needs) form (energy) for effect (motion).

Fiona

"The sun is our main source of energy for life, because plants and humans need it."

Here the format is as follows: not alive, source (sun), verb (needs) form (energy), because (reason).

Michael

Michael's work provides a good example of how the network accounts for pupils' conceptions. The example below is full of description, however the ideas can be represented by the network in the following way:

- 1 Energy (nature of) generalised, Principal component (source) sun, Relation to energy (gives) Form (light);
- 2 Energy (nature of) generalised, Principal component (user) person, Action/Effect (running);
- 3 Principal component (source) food, Relation to energy (need), Action/Effect (activity as in living).

"We see energy in our world through all different types of objects. When we think of energy many things are pictured in our minds. For example, we think of electric fires, the sun, water, windmills, cookers, people running, and moving

"In order to use energy we must discover what provides it

"The sun provides energy by light and helping things to grow

Neil

"Energy is gas, sun, water, coal, and wind."

"We use food energy ourselves, electricity in batteries".

Although harder to interpret, these examples still fit the network, Alive (person), relation to energy (use), form (food energy). Principal component (source) sun, relation to energy (is).

Louise

"Energy is a source of power which can be used in all sorts of ways. It can be put into a car, into yourself, or you can find it in water. Energy is power, energy is realised from a variety of sources. Energy is responsible for making things go all sorts of things use energy, cars, people."

There are two distinct elements here that are well represented by the network:

- (a) Alive, user (person), makes things go (active);
- (b) Not alive user (car) makes things go (effect);

Tracy

"Humans run on food that is our power source."

"Energy has many definitions I think that we can see energy through people riding, jogging and talking."

Here the representations are, Animacy, alive (person), principal component (source) food, Action/effect (activity) riding, jogging.

Class 3

Jacky

"Energy is a source of power and we need it to help us live and walk and it comes from lots of things like wind, rain, clouds."

From the network the representation is alive (person), verb (need), to live (activity).

Polly

"Energy is GO. Food is our energy, and if we are ill we don't have any energy to get up Petrol, oil, gas or electricity are other sources of energy for transport and other things."

From the network:

- (a) Alive (person), verb (needs), source (food), to live (activity);
- (b) Not alive (transport), verb (needs), source (fuel), to move (activity);

David

"Energy is very special and vital to human life. It keeps people warm, as well as powering calculators to nuclear missiles. Many animals are able to produce their own energy."

From the network it can be seen that energy is required to live, source (energy), verb (need), activity (to live), Alive (animal, person).

Michael

"Energy is very special for without it we could not live. There are many things we can produce energy from, like the sun, and water. Heat is an important form of energy, that we rely on every day in our homes."

From the network it can be seen that energy, verb (need) activity (live), source (sun, water), alive (person).

The network shows how most of the notions of energy as portrayed by the pupils can be expressed. Most of the pupils' statements fit each of its categories labelled in the network, however it is not necessary for this to

happen on every occasion. The network makes no reference to changing forms of energy, this is because no instances, except for one which is questionable (cf Chapter 8, 8.3.4), were found in the younger pupils work. Although examples are quoted later from the older pupils, insufficient examples were found to contribute effectively to the network.

The above examples show how the network gives an account of how the pupils represent their ideas of energy. In the case of the younger pupils it is often difficult to decide exactly what they are trying to say, making interpretation somewhat problematic. Such problematic cases will be discussed as they arise.

The network does appear to fit the pupils' work of all abilities, however if any comment is to be made on how, if at all, the network can help to examine the cognitive level of the pupils' work, a closer examination of these examples is required.

Analysis Through Cognitive Level

The analysis in this section is guided by the question:

"Does the work reflect the cognitive levels of the pupils?"

It will first look at the six pupils from classes 1a and 1b, and the four pupils from class 3, in more detail than above, in order to establish whether their representations of energy match with the cognitive levels as in Table 8.1-6 taken from the Shayer and Adey Taxonomy. Secondly,

a series of tasks specifically related to certain cognitive levels demanded by the software will be examined in relation to the pupils work, to see if the levels are reflected there also.

Class 1a and 1b

Sarah, Fiona and Michael, were all rated as high ability by their teachers, and attained a Piagetian level of +2B/3A, on the SRT tasks. Neil, Louise, and Tracy, were rated as average to below average pupils by their teachers and attained Piagetian levels of 2A/2B. These levels can now be compared with (Table 8.1-6) with respect to the minimum cognitive level required to understand various energy related concepts. The section most relevant to the discussion is P10 Energy and Power.

It would seem from the extract given previously, and from their network representations, that all six pupils in classes 1a and 1b recognise that energy has many sources and that work is expended energy. However Neil, Louise and Tracy show no evidence of being able to differentiate "power" from "work", whereas Sarah, Fiona, and Michael do show the beginnings of such a differentiation, but not consistently as in the case of Sarah, stating that "energy is power".

Class 3

Jacky achieved a 2A/2B Piagetian level, and was rated as slightly below average for her class by her teacher. Polly and David were rated as average to slightly above

average for their class and achieved a Piagetian level of 2B/2B+. Michael was an example of the highest ability in the class and achieved a Piagetian level of +2B/3A.

From Jacky's and Polly's classifications of energy (see quoted extracts) it can be seen that they associate energy with living things, or the "go of things". There is evidence that the pupils see energy as having many sources, however there is no real evidence, with the exception of Michael, that work is expended energy, or that power can be differentiated from work. Bearing in mind that the minimum level required to understand these ideas is 2B, it is not surprising that there is little written evidence showing such differentiations.

The tables below show that the types of response discussed above are representative of the classes in general and not merely chosen to suit the argument. From the Shayer Taxonomy the minimum level required for understanding Energy/Power concepts is 2B/3A. The concepts required by the level indicate:

- 1 Work is expended energy;
- 2 Energy has many sources;
- 3 Power can be differentiated from work.

Each pupils' work was examined for evidence of the above concepts. If such evidence was found it was then compared to their cognitive level as determined by the SRT results (Appendix 13). Table 8.2-1 shows the total number of pupils at each cognitive level, for each class respectively.

TABLE 8.2-1

CLASS	NUMBER OF PUPILS AT EACH COGNITIVE LEVEL			
	3A	2B	2A/2B	2A
CLASS 1a	1	19	6	0
CLASS 1b	3	17	11	6
CLASS 3	0	12	14	0

Table 8.2-2 shows how many pupils at each recorded cognitive level showed evidence of "Work being considered as expended energy".

TABLE 8.2-2

WORK IS EXPENDED ENERGY				
CLASS	NUMBER OF PUPILS AT EACH COGNITIVE LEVEL SHOWING EVIDENCE OF CONCEPT			
	3A	2B	2A/2B	2A
CLASS 1a	1	19	2	0
CLASS 1b	1	15	5	2
CLASS 3	0	11	7	0

Table 8.2-3 shows how many pupils at each recorded cognitive level showed evidence of energy having many sources.

TABLE 8.2-3

ENERGY HAS MANY SOURCES				
CLASS	NUMBER OF PUPILS AT EACH COGNITIVE LEVEL SHOWING EVIDENCE OF CONCEPT			
	3A	2B	2A/2B	2A
CLASS 1a	1	19	4	0
CLASS 1b	2	15	10	5
CLASS 3	0	11	13	0

With respect to the third concept "Power can be differentiated from work", only one case can be reported, and is questionable in its interpretation. This comes from Sarah whose estimated cognitive level is 3A.

"Energy is all round us, when I turn on the light I know electricity is causing the brightness As I walk to school the wind reminds me of the power of the windmill. The sound of car engines is full of energy, and a coal lorry reminds me of a source of energy. Throughout the day the sun beats down with its own solar energy, and the sea crashes in the distance with its own wave power".

Her explanation could be taken as a possible indication that a differentiation between power and energy is forming or that she regards "power" as in "powerful" not as in "rate of working". However what can be considered from this is that no concrete evidence was found to show that the pupils could cope with this particular concept.

In conclusion it could be said that these tables give an indication of how many pupils at various levels show evidence of working at a particular level that is different to their estimated level of cognition as found in the SRTs.

Considering the concept "Work is expended energy", it can be seen that the majority of the pupils at levels 3A and 2B show some evidence of the concept, however there are a greater number of pupils showing evidence of 2B thinking in class 3 than one would expect, with few showing evidence of the concept at the lower levels of cognition ie 2A/2B and 2A. The concept "energy has many sources" does not appear to pose a great problem with any of the pupils as the majority of pupils at each recorded level appear to show some evidence of understanding that energy has many sources.

However in order to consolidate these results and to be able to confirm that the pupils are working at certain cognitive levels, other areas of their work need to be explored. This will be done through a series of tasks which were chosen as directly relating to the software, but with distinct cognitive levels attached to each task, in this way assessing how well the work reflects the pupils Piagetian level and at the same time seeing how they coped with the predicted problem areas.

8.3 ANALYSIS THROUGH TASKS

The data in this section was collected from a series of tasks given to various groups of pupils from both schools. The group sizes were usually 6 to 8, the groups being of mixed ability, and chosen by the class teacher.

Rationale

Each task was set with specific cognitive levels in mind. Each response is then considered for an estimate of its cognitive level, in this way attempting to see if the pupils work does in fact reflect their cognitive level.

Task 1

A detailed description of CEDRIC 2.1 has been given in Chapter 3. The program includes vocabulary that is not used every day by pupils. The first task was designed to see what knowledge the pupils had concerning insulation, and conservation of energy. Groups of pupils from both Primary schools were asked to answer the following questions:

- 1 What is double glazing, and where did you learn about it?
- 2 What is cavity wall insulation, and where did you learn about it?
- 3 What does insulation mean?
- 4 What does conservation mean?
- 5 What does the conservation of energy mean?

There were a variety of answers to these questions, (all of which can be found in Appendix 16), the most interesting of which are quoted below.

Example 1

"Double glazing keeps the house warm because it is two layers of glass and therefore keeps more in the house, because the heat has to get through two layers of glass before it can escape".

The estimated cognitive level of the above comments is 2B, using the Curriculum Analysis Taxonomy, section 1.2, "Reasoning for events". The explanation given indicates the use of bipolar events, ie the more glass there is, the more heat kept in the house, however no formal explanation is given. There appears to be a distinction between heat and temperature; however there is no direct evidence to show that heat has been fully conceptualized. This example can be considered as indicative of 2B thinking. The SRT level for this pupil was 2B.

Example 2

"Cavity wall insulation is I think a kind of gap which is between two walls. I think they put foam in it to save energy and to keep the cold from coming into the house".

The estimated cognitive level of this statement is 2A/2B: (Table 8.1-4 section 1.2) the explanation given uses bipolar events. In addition it is interesting to note that the pupil sees energy saving as keeping cold from coming in, which may reflect 2A thinking where heat and temperature are not distinguished. The SRT level was 2A/2B, consistent with the above diagnosis of the thinking.

Example 3

"Insulation means trying to stop heat from escaping from the main living quarters. We would find insulation in lofts and walls".

This example is more difficult to categorise as it lacks detail. Its level might be estimated at 2B, since there appears to be a distinction between heat and temperature. The SRT results for this pupil was also 2B.

Example 4

"Energy means fuel for life. It also means the food we eat converts into glucose which gives us the strength to move".

This is a good example of how energy is often conceptualized by this age range. It possibly fits the 2B description "Work is seen as expended energy", but seen in a totally anthropomorphic way, (again 2B). The SRT result for this pupil was 2B/3A.

Conservation of energy in the scientific sense, requires at least a level of 3A. Thus not many examples of it would be expected to be found. Example 5 below is a case where it is wholly absent, while Example 6 shows a more scientific appreciation beginning to emerge. However, in many cases, the "Ecological" interpretation remains dominant.

Example 5

"Conservation is to save things like Pandas, Lions and Birds".

Example 6

"Conservation of energy is when it is stored somewhere or used in a sensible way".

The cognitive level of this pupil was 2B.

These examples were chosen to illustrate the diversity of ideas the pupils held, and how they reflect the cognitive levels generally. However they are representative of many of the responses.

Task 2

This involved the children in data collection, measurement skills, and the interpretation of the data they had collected. Each element required a minimum cognitive level of 2A/2B. The pupils were given revised data collection sheet (Chapter 6), to complete, and subsequently put the collected data into the program, obtaining a DHL (Designed Heat Loss) value for the house. Pupils were asked to comment on it.

The majority of the older and more able pupils found little difficulty in collecting the relevant information as described in Chapter 6. However, the younger and less able pupils required direction in completing the data sheets. Pupils from all classes found calculation on area and volume difficult, the majority of the problems occurred with the younger pupils in class 3 and the less able from all the classes. In terms of cognitive level this would be expected. For calculations of area a minimum level of 2B is required and 3A for volume. This would agree with the nature of the difficulties encountered by the pupils, considering

that the majority of class 3 were at level 2A/2B, and classes 1a and 1b at level 2B, with less able pupils at level 2A/2B.

Giving simple examples of calculation methods did help pupils to a certain extent. This type of assistance is considered in detail with respect to percentages later (cf Task 4).

Task 3

The pupils were asked to construct a scaled down version of their house using the information they had collected, and had found through using the program. The task was to construct a model using a shoe box. The box represented the layout of the house, including windows, doors, etc. The insulating material used was to be the pupil's choice. Each step of the construction and development was recorded.

The task demands can be separated into various operations requiring certain cognitive levels, based on sections 1.1 and 1.6 of the Curriculum Analysis Taxonomy (Table 8.1-4). These can be summarised as follows:

- (a) Investigations, (section 1.1) it can be seen that at 2B the pupils should find:

"Interest in making and checking cause-and-effect predictions".

- (b) Depth of interpretations, (section 1.6):

"Takes several aspects of described situations into account, but separately, and in imposing cause-effects stay within the descriptions, mostly redescribes it".

Ordinal scale level of interpretation. Level 2B.

As predicted above, the scaling down proved difficult. The younger pupils had very little idea of what was expected of them, whilst the older pupils required a great deal of help with using scales, in terms of the type and nature of the scale. This can be seen in figure 8.2-4, in which the pupil has simply chosen to draw the diagrams, but gives no mathematical basis for the construction. This would be in agreement with the Curriculum Analysis Taxonomy section 2.2, (Table 8.1-5). It suggests that pupils require a minimum level of 3A to use more than an ordinal scale, and to achieve ratios of more complicated numbers, and as only three pupils had attained this level from all the classes, the result is not surprising. However the task was accomplished but without numerical representation (ie ordinally). The pupils did manage to investigate the problems of insulation, and energy conservation in a way that reflected 2B thinking. Examples of this work can be seen in figure 8.2-5. The most noticeable point is that there seemed to be general understanding of the concept of insulation, yet the work is such that these concepts are being stated rather than explained in a meaningful way, which is indicative of level 2A/2B. Examples are given below.

Example 1

"For the roof use some cardboard into a point then cover the underneath with cotton wool to give insulation".

Example 2

"Cavity wall insulation is a very effective way of keeping energy in the house".

FIGURE 8.2-4

Michael: Age 11: Cognitive Level + 2B/3A

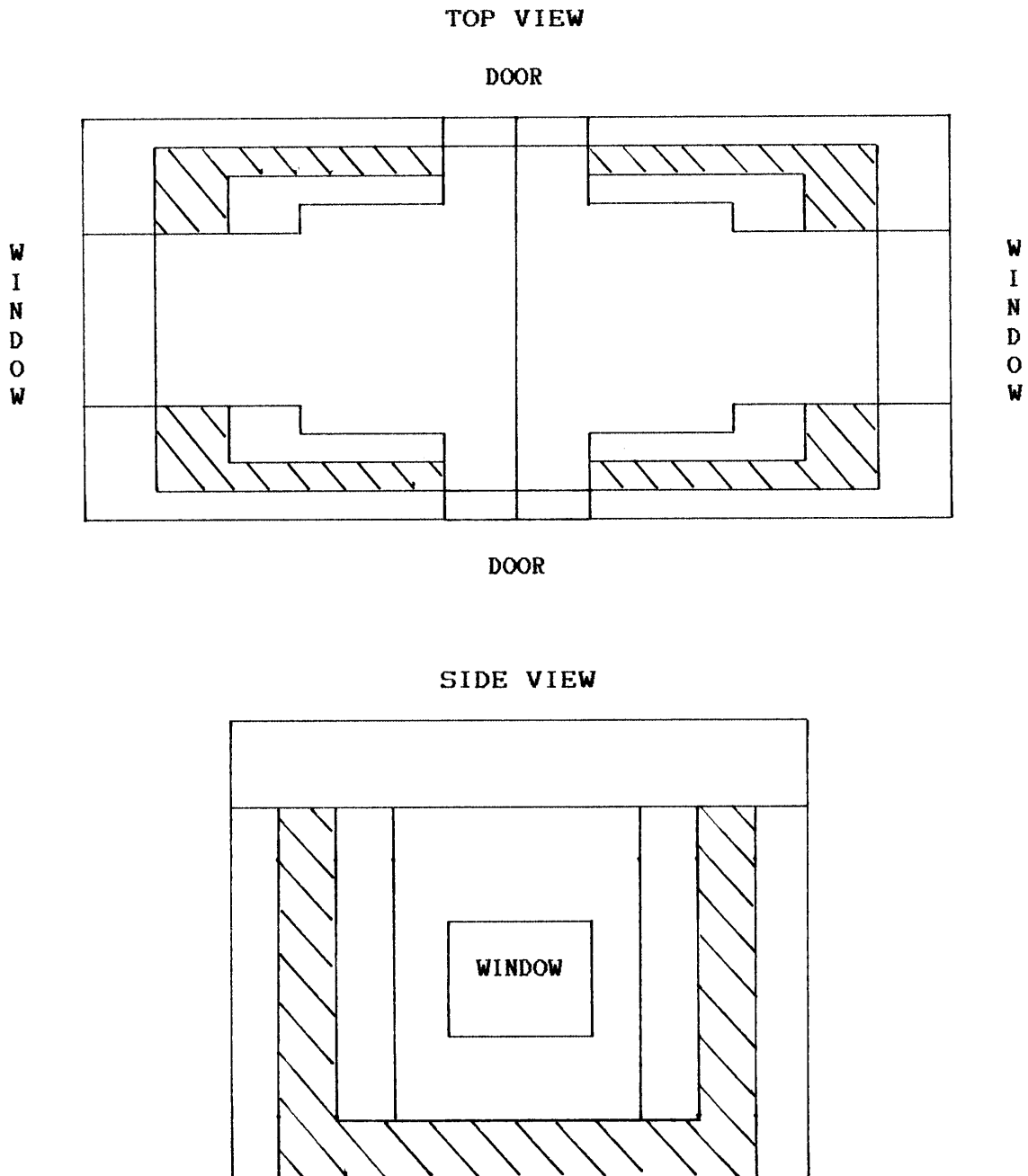

Full documentation of work: Appendix 17.

FIGURE 8.2-5

Stage 2

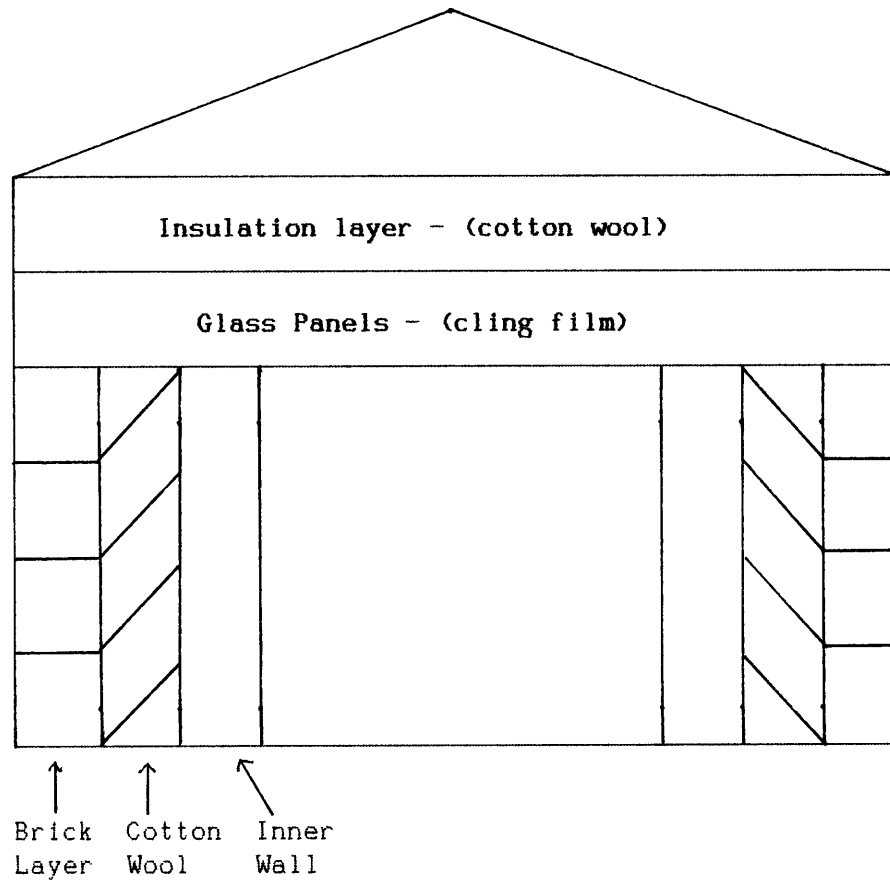

Cavity Walls

The second stage in our bungalow was to-fit cavity walls. Cavity walls consist of two walls a few inches apart with a layer of foam in the middle. This means that any air trapped in between the two walls will stop energy from escaping.

Both example 1 and 2 appear to show that the pupils realise that insulation is needed, what to use for insulation as in the suggestion of cotton wool, and that insulation keeps energy in the house, but neither example gives any reasoning for such

suggestions, being therefore indicative of 2A/2B thinking, in which cause-effect reasoning is only partially structured.

The fourth task was to see if the pupils could manipulate figures given on the data sheet obtained at the end of the program, which were notably on percentages, (one example has been discussed in section 8.1). However here the pupils worked through some simple percentage questions, giving explanations for each step they took in order to establish what process they were using, in relation to their cognitive level. The point of this task was to see why there had been problems with the original task on percentages as illustrated in Chapter 8 section 8.1.5.

Task 4

Question 1

"You have £40 pocket money and you have spent 20% of it. How much have you got left?"

Question 2

"Pocket money saved £55, you spend 25% of your money. How much have you got left?"

Both these questions were looking for evidence that pupils could make inferences from the data involving ratios. The numbers were chosen specifically so that only small whole numbers, representative of 2B thinking, need to be considered.

None of the pupils appeared to have any problems with the examples below.

<u>Example 1</u>	<u>Example 2</u>	<u>Example 3</u>
20% = $\frac{1}{5}$	25% is the same as $\frac{1}{4}$	25% = $\frac{1}{4}$
$\frac{1}{5}$ of £40 = £8	25% = $\frac{1}{4}$	$\frac{1}{4}$ of £55 = $13\frac{3}{4}$
£40 - £8 = £32	Hence $\frac{55}{4} = £13.75$	$\frac{3}{4}$ of £1 = .75p
Answer £32	£55 - £13.75 = £41.25	Hence £13.75
	Answer £41.25	£55 - £13.75 = £41.25
		Answer £41.25

From these results it can be seen that the pupils found no difficulty in coping with the mechanics of calculations of percentages, and simple ratios. Yet faced with the print out from the program, as discussed in section 8.1.5 they found it difficult to appreciate what the numbers represented, and therefore found them difficult to analyse and complete calculations on. Often these numbers were complex, for example 393.4 and 116.9 (Table 8.1-7).

A possible explanation in view of the above evidence is that although the pupils can manipulate simple ratios, as can be seen in Examples 1 and 2 of Task 4 which is reflective of 2B thinking, using more complex numbers requires a higher level of understanding, which they have not yet reached.

8.3.1 Some Conclusions

Examination of the tasks set would seem to indicate that there is a relationship between the work completed by the pupils and their cognitive level. The predicted problem

areas do seem to materialise, both at an individual level and at class level.

Task 1, reflects the way pupils consider insulation and conservation of energy in a domestic situation. As such it showed that the majority of the pupils were thinking about the above concepts at a level of 2B, which was intuitive and anthropomorphic in nature, indicative of this level. Interesting comments did arise such as, "keeping the cold out", however when such comments were compared to the pupils' cognitive level the statement was not surprising, as the pupil's level was 2A.

Task 2, investigated data collection skills and interpretation of that data. The minimum cognitive level required for collecting data of this kind is 2A/2B, and for completing the required calculations and interpreting the results 2B/3A. The results of Task 2 appeared to show that the areas requiring high cognitive levels of reasoning, such as ratios and volume, did in fact prove difficult. Further evidence of this was found in Task 3 and 4, which appeared to highlight the problems the pupils had in calculating and interpreting percentages.

These findings raise some important issues, with respect to the way software could be used to help pupils manipulate difficult numerical problems, and the way in which teachers could observe the methods used by pupils in trying to solve these types of problems. Such a discussion can be found in Chapter 9.

Having seen that pupils' work does appear to reflect their cognitive level it would seem necessary to consider the third question posed:

"To what extent does the work help us to understand any relations between the CSMS tasks and the energy questionnaire?"

8.4 LOOKING AT THE PUPILS' IDEAS OF ENERGY IN RELATION TO THEIR COGNITIVE LEVEL

The data in this section are taken from the results of the energy questionnaire (Chapter 7, section 7.2), and the results from the CSMS tasks (Chapter 8, section 8.1), and examined to see what, if any, relations exist between the two sets of data.

The Rationale

The energy questionnaire suggested a structure for the way pupils thought about energy, while the CSMS tasks gave indications of their cognitive levels. The problems encountered could be related to both the above causes. In order to substantiate such a notion it will be necessary to look at individual pupils of varying ages to see if the ideas about energy can be related to cognitive level.

8.4.1 Summarising the Data

The results from the energy questionnaire (Chapter 7) indicate that pupils aged between 10 and 11+ see energy in two distinctive ways, that of "Source v Consumer", and of being strongly associated with activity. The older pupils tended to see energy more as "Source v Consumer" than the younger pupils, not giving so much attention to the simple equation of energy with activity.

The CSMS tasks gave indications of the general levels of reasoning that one could expect from 10 to 11 year old pupils, these being in the region of early concrete, and late concrete operational thinking.

The energy network gave a representation of how the pupils viewed the notion of energy.

8.4.2 Analysis

Two pupils from each class will be considered, one with a high cognitive level and one lower, using the results of the SRTs as a guide to their levels.

Class 3

Polly age 10.3 years, cognitive level 2B/+2B.

Jacky age 10.4 years, cognitive level 2A/2B.

Piaget (1947) when discussing the construction of operations suggests that:

"From 7-8 to 11-12 years 'concrete operations' are organised, ie operational groupings of thought concerning objects that can be manipulated or known through the senses."
(p 123)

Central to his argument is the idea of "action":

"There is the level of operations, which concerns transformations of reality by means of internalized actions that are grouped into coherent reversible systems"

However he goes on to argue that these internalized actions are characterized by obstacles, these are:

"That a successful adaptive action is not automatically accompanied by an accurate mental representation of the situation or of the action performed."
(pp 93-94)

This would suggest that this stage of development involves the problem of mentally representing what has already been absorbed on the level of action. Concrete operational reasoning can therefore be said to relate directly to objects and groups of objects (classes), and to relations between objects. In this way logical organisation of judgements and arguments can be made, but are inseparable from their content. Here operations function only with reference to observations or representations regarded as true, not based on hypothesis.

From this it is possible to surmise that a child's reasoning at this level is not independent of situations, his thinking being effective only to the extent that it is concerned with a particular concrete situation.

If Polly's and Jacky's work is now considered (section 8.2.3) it shows quite clearly that energy is seen very much in terms of activity, and that activity is human orientated, as shown in the statements such as "Energy makes us go." This notion is picked up in the second dimension of the multidimensional scaling maps, arising from the results of the energy questionnaire for the younger pupils, which highlights the connection between energy and activity. Certain interesting points do appear when examining the way the above two pupils reason about energy. Polly appears to be able to

articulate slightly better as to what energy means to her, and how sources of energy relate to certain objects, for example "food is our energy", "petrol, oil, etc, are other sources of energy for transport and other things."

These types of comments would be expected from the level of cognition which Polly is at, not only in terms of energy as stated in the Curriculum Analysis Taxonomy, but from Piagetian generalizations about concrete operational thought. Jacky on the other hand mixes energy, power, action source and living all together. For example:

"Energy is a source of power and we need it to help us live and walk and it comes from lots of things like wind, rain, clouds."

Using the taxonomy the fact Jacky shows that energy has various sources albeit in a restricted way, would suggest reasoning of "early concrete operations", however the way in which she tries to explain her ideas gives indication that her reasoning is very tentative, making her generalizations weak. Concrete operations are regarded as:

"Providing a transition between schemes of action and the general logical structures Concrete operations are already co-ordinated into overall structures, but these structures are weak and permit only step by step reasoning for lack of generalized combinations."
(Piaget and Inhelder 1966 p100)

Polly and Jacky appear to fit concrete operational reasoning but with significant differences which can be found by using the energy network to give a representation of their ideas, and that these ideas appear to fit what is

expected of pupils at their respective cognitive level. For example Polly being at late concrete operations would be expected to structure simple cause-effect notions as can be seen in her second statement. Her first statement clearly shows that her reasoning relates to action and the relationship between objects, ie the connection between staying alive, food and energy. These connections would seem to come from observations rather than hypothesis, indicative of Polly's cognitive level.

Polly

- 1 "Energy helps us to stay alive. It gives us heat for houses and allows us to cook food."
- 2 "Food is made into energy by our body."

From the network: Animacy (alive) person, Action/effect (state) alive. Energy (generalized) form (heat), Activity (cook). Animacy (alive) person, Principal component (source) food.

Jacky

- 1 "Energy is a source of power and we need it to live"
- 2 "It helps us in two ways, electricity and helping us to move. First it helps to keep warm and give us things to watch."

From the network: Animacy (alive) person, verb (need), Activity (live). Animacy (not alive), Principal Component (source) electricity and (user) person, Relation to energy (need), Action/effect (activity) to move, (state) warm.

Jacky's reasoning appears to show cause-effect relationships but they seem to be only partly structured, and to use associative reasoning which is indicative of early concrete operational thought. Her conception of energy also fits this level of reasoning as found in the Shayer Taxonomy. (Table 8.1-4).

The Energy Questionnaire gives a structure to the way pupils of this age view energy, and is representative of their conceptions, however weak these conceptions may be, as demonstrated in the second dimension of the MDS map.

The cognitive level of these conceptions (as represented in the Shayer Taxonomy) can be compared with the types of reasoning pupils are using in their written responses, as found in their class work (for example, step by step reasoning that lacks generalization and abstraction). Such a comparison would suggest that pupils could be attributed to a level of operations such as "concrete operational thinking". This could then be substantiated by referring to the general expected cognitive level of pupils within this age range.

If that above suggestion is accepted, an interesting issue for the research arises, if we consider Sarah age 11, with a cognitive level of 2B\3A, as this level is considered as being exceptional for her age when compared to both the class average and the national average.

3A is associated with "early formal operational thinking." What relevance does this have here? It is necessary to consider what formal reasoning entails. Piaget states that:

"By means of differentiation of form and content, the subject becomes capable of reasoning correctly about propositions he does not believe, or at least not yet; that is proposition that he considers pure hypotheses. He becomes capable of drawing the necessary conclusion from truths which are merely possible, which constitutes the beginning of hypothetico-deductive or formal thought."
(Piaget and Inhelder 1966, p 132)

From this one might assume that a major characteristic of formal operational thought is the ability to think about many possible eventualities; this permits an escape from the limitations of immediate reality and helps to promote hypothetico-deductive thinking. This then allows the pupil to tackle problems by systematically considering all of the factors in that problem. This could be summarised by saying that pupils at this level should show a progression in reasoning with respect to generalizations and abstractions. This type of reasoning is expected from older pupils, aged 12+.

If there is some connection between pupils prior conceptions and cognitive level, it is necessary to examine some of the work produced by the pupils that might be expected to show some form of formal reasoning, by nature of their cognitive level. In addition to this it is necessary to see how these pupils view energy. Here the energy network will be used to give a representation of the pupils conceptions, which can then be considered with respect to the energy questionnaire and finally their cognitive level.

From Piaget's description the types of reasoning expected would be evidence of early generalizations and abstractions. If Sarah (aged 11) and Michael's (aged 11.10) work is considered (extracts of which can be found in section 8.2.3) it is possible to see that both define sources of energy specifically, and try to give reasons for various aspects of energy. Michael's work shows that a more generalized reasoning is beginning to appear, rather than considering energy simply in "active" terms, for example:

"In order to use energy we must discover what provides it. The sun provides energy by light, and helps things to grow."

However the human criteria still exists,

"Food keeps humans living."

The network helps to give a representation of these statements:

- 1 Animacy (not alive), Principal Component (source) sun, Nature of energy (form) light, Consequence (helps things to grow).
- 2 Animacy (alive) person, Principal Component (source) food, verb (need), Effect (living).

Example one shows that Michael is reasoning with several objects, and tries to reach a deduction through considering the possibilities. The reasoning appears to be as follows; to use energy we need to know what provides energy, then we can explain certain effects. Even though this is simplistic it does indicate that a deeper level of thought has occurred, possibly indicative of early formal operational thought.

Michael was one of the oldest pupils in the class as well as having a high cognitive level, it is therefore possible to say that his ideas have developed with age, although his cognitive level is higher than would be expect at this age. However if we assume that prior conceptions change with cognitive level, age should not necessarily be important. If this is the case, Sarah's results become of interest to the research. Sarah, with a cognitive level of 3A, was almost a year younger than the rest of her class and therefore an academic year "ahead" of herself. It is therefore interesting to see how she conceptualizes energy. Some of her work has been considered in section 8.2.3, where she discusses power:

"The sea crashes in the distance with its own wave power."

As have been suggested previously, Sarah does not actually differentiate power as a rate of working, but appears to consider power as in "powerful", yet this type of reasoning is beyond basic concrete operational thought, but not quite formal. It is possible that Sarah is at a transitional stage, and that the particular logical form (rate of work) is still not independent of its concrete content.

Further examination of Sarah's work shows statements such as:

"Energy is a source of heat,"

and:

"Energy is all around us in different sources, when I turn on the light I know electricity is causing the brightness heating the water and the humming of the fridge."

These two statements indicate a difference in the way Sarah considers energy from many pupils of her age, and seem indicative of her cognitive level. For example the energy activity association is not present in the above statements, the only evidence found of this association is a statement that the "body needs food for its energy." Sarah's reasoning appears to allow for the possibility that energy can be considered in a more abstract way in terms of cause and effect, For example she states that energy is all around us, but has many sources one of which is electricity which causes several effects, albeit that these relationships appear to be established with concrete schemas, this in itself being indicative of early formal operational reasoning.

8.4.3 Some Conclusions

Michael's and Sarah's conceptions of energy appear to fit with the ideas held by older pupils (who would be expected to have a higher cognitive level) as described in the results of the energy questionnaire in Chapter 7. They both appear to place less importance on the energy-activity equation, but do not lose the source/user division in their conceptions of energy. This has also been apparent when examining their statements through the Energy network. What has shown to be interesting is that a tentative exploration of Sarah's and Michael's ideas about energy and the way they appear to reason, does seem to reflect their cognitive ability as estimated by the SRT results rather than their ages.

What is being suggested here is that there is a possible connection between prior conceptions and cognitive level. Sarah is a good test case, with a cognitive level which is exceptional for her age, and whose prior conceptions appear to match her cognitive level, not her age. The same could be argued for Michael.

8.5 CONSIDERING THE SECONDARY SCHOOL PUPILS

8.5.1 Introduction

The aim of this section is to consider the work produced by the Secondary school pupils in the light of the conclusions drawn from the Primary school analysis. Due to the examination constraints these pupils were unable to complete the SRTs. However they did complete the energy questionnaire before and after the project, as well as submitting project work. Both sets of data have been analysed in a similar way to that for the Primary schools.

8.5.2 Rationale

Using the conclusions drawn in Chapter 8, 8.1.2, from the Primary schools, (in terms of cognitive level of pupils, cognitive demands of software, and analysis of energy ideas from the network) the aim is to show that a certain level of cognition - somewhat higher - would be expected to be found in pupils aged 13+. However as there are no cognitive levels of the pupils to refer to, the pupils' work will be examined in three ways:

- (a) The way they think about energy, using the network;
- (b) The demands of the software and how they coped with it;
- (c) The work the pupils completed.

This will then be used to estimate at what level the pupils are working. In this way the predicted level can be compared to the national average to see if the pupils are in fact working at a higher level of cognition than the younger pupils, ie that which is expected of 13 to 14 year olds.

8.5.3 Analysis

Using the Network

The network constructed in Chapter 8, 8.2.1 is used here to analyse the older pupils' work.

Heidi

"Energy is something that powers and controls things, eg the energy from electricity powers the television Energy can also make more energy, eg energy from Uranium (I think) gives energy to make nuclear energy."

From the network the first statement indicates that: Not alive (television), source (electricity), verb (powers), effect (picture).

From the second statement: Not alive (energy), source (uranium) verb (makes) effect (nuclear energy).

Donna

"Energy is power, or strength that can be used to make a car work, in that case the energy is petrol."

This fits the network well: Not alive (car), source (petrol), action (work/movement).

Emma

"Energy is things such as heat and food. We need food to give us energy."

From the network: Alive (person), source (heat, food), verb (need) action/effect (to live).

Charlotte

"Energy is something that gives power to other things, eg electricity. It makes other things work. If it wasn't for energy people wouldn't be able to move."

From the network: Not alive (things) source (electricity) verb (gives) effect (works). Alive (person) source (energy) action (move).

This cross-section of examples shows that the network appears to fit the older pupils' work equally well. However if the network is to help predict the cognitive level at which the pupils are thinking a closer examination is required. Using the Shayer analysis (Figure 8.1-1) for the age range considered here, 13/14 years old, one would expect 97% to 100% to have reached 2A, 77% to 85% 2B, 20% to 30% 3A and 5% to 10% 3B. Shayer suggests that one cannot expect more than 20% of an average third year class to have formal operational thinking.

From Figure 8.1-1 an estimated 5% to 10% of pupils should have reached formal operational thought as described in the previous section (8.3.3). In terms of energy this involves appreciating the following:

- 1 The first law of thermodynamics and equilibrium;
- 2 Equivalence of different energy forms having a capacity (extensive) and a potential (intensive) aspect;
- 3 Energy as a product of these factors;
- 4 Appreciate problems of heat as a form of energy is only partly convertible to work. [Shayer 1979, see also Table 8.1-6].

These four features are limited in their usefulness in trying to assess the older pupils' cognitive level with respect to energy for the present work, as the software used did not directly approach all of the above aspects. However, examining the way the pupils reason about energy can give indications as to how they are generalizing and using abstractions. It is therefore necessary to use examples from the pupils work in order to try to estimate at what level the pupils are thinking.

Donna

"Energy is power, or strength that can be used to make a car work, in this case the energy is petrol.

Food is energy that was (I think) chemical energy, but we burn it up and change it to another kind of energy, but I don't know what it is called."

This example shows that although energy and power have not been adequately differentiated, energy and work have. This requires 2B (late concrete operations). Donna's statement indicates appreciation that energy has various

forms and can change from one form to another. The Shayer taxonomy suggest that to think of energy changes in terms of their implicit and explicit nature requires formal operational reasoning; Donna's statement does not fit this requirement, however she does appear to show some knowledge of energy changes which requires a degree of abstraction beyond concrete operations, but not necessarily complete formal operational thinking. A possible estimate of Donna's cognitive level is +2B/3A.

Charlotte

"Energy is something that gives power to other things eg electricity. It makes other things work."

Charlotte appears to distinguish energy from work, indicative of 2B thinking, but the statement gives no indication of higher level thought.

Heidi

"Energy can also make more energy eg energy from Uranium (I think) gives energy to make nuclear energy."

Heidi's statement indicates that she is beginning to realise that energy has different forms and can be converted; here again the Shayer taxonomy does not help directly in estimating the pupil's cognitive level from the view of energy, however, examining the reasoning in the statement allows for the possibility of a cause that is not in 1:1 correspondence with observations as in the case of Uranium and Nuclear energy. This type of reasoning could be attributed to early formal thought.

What is particularly interesting with these examples is that although the Shayer taxonomy does not appear helpful in the area of energy concepts at formal operational level, it is possible to examine the pupils in the way that they generalize and hypothesis as a way of estimating their cognitive level, with the aid of Table 8.1-4. The process is not an easy one. From this type of analysis it would be possible to say that a few of the pupils are showing signs of formal operational thinking, albeit in its early stages. In order to show how representative these examples are of the pupils work, the table below gives a simple indication of how many pupils made responses at each estimated Piagetian level.

TABLE 8.5-1		TOTAL NUMBER OF GIRLS 23	
TOPIC	ESTIMATED PIAGETIAN LEVEL	NUMBER OF GIRLS	
Energy has many forms	2B	23	
Work is expended energy	2B	20	
Power is differentiated from work	2B	13	
Power seen as work done	3A	2	
Equivalence of different energy forms	3B	2	
Heat as a form of energy	3B	3	
Conservation of energy as learnt fact	3A	4	

The results above highlight the problems in estimating the pupils' cognitive levels through using the Shayer taxonomy for energy concepts. However, more useful information can be gained from the first taxonomy (Table 8.1-4) on different aspects of the development of the child's interaction with the world. Table 8.5-2 shows how many pupils showed evidence of reasoning at each estimated Piagetian level, that was appropriate to the tasks set from the software.

TABLE 8.5-2	TOTAL NUMBER OF GIRLS 23	
TOPIC: REASON FOR EVENTS	ESTIMATED PIAGETIAN LEVEL	NUMBER OF GIRLS SHOWING EVIDENCE OF LEVEL
Cause - effect structured according to general concrete stage	2B	23
Can use ordering relationships to partially quantify associative relations	2B	20
Looks for some causative necessity behind relations established with concrete schemas	3A	15
Consider the possibility of multiple causes for one effect, or multiple effects of one cause	3A	12

From Table 8.5-1 and 8.5-2 it is possible to suggest that a large proportion of these pupils were at a transitional stage of operational thinking, ie 2B/3A. The results indicate that a higher proportion of the older pupils have a higher cognitive level than the Primary pupils, as one would expect.

Evidence for the pupils having a higher cognitive level than the Primary pupils can also be found in the older pupils' project work relating to data from the software. A good example is Melanie (age 13.9). Having used the software to calculate the Design Heat Loss (DHL) of her house, she then goes on to explain possible reasons why her results are different from those of the rest of the group.

"Everyone's results are different because their houses are heated differently and they use different types of insulation. Also the type of house they live in, because if you live in a terraced house the house next door's walls give you some insulation."

From the Curriculum Analysis Taxonomy, a pupil that describes and interprets information taking account of more than one aspect is said to be at early formal operational thinking, of which the above example is indicative.

This type of interpretation was to be found in most of the pupils' work. Collecting the data and then analysing the results were not as problematic for the older pupils as the younger ones. The demands of the software in terms of mathematical concepts were completed by the pupils with few problems. Figure 8.5-1 is an example of such work. This is further evidence that the pupils are at a higher level of cognition than the younger pupils, as many of the mathematical tasks required a minimum of late concrete operational reasoning, with some at the level of early formal operational reasoning.

8.5.4 Some Conclusions

The aim of this section of the analysis was to see if the predictive nature of the Curriculum Analysis Taxonomy, would show whether the Secondary pupils did have a higher cognitive level, as one would expect. The examples chosen indicate that this prediction is difficult from the energy aspects of the taxonomy alone, however when considering how the pupils reason within their responses there is evidence to justify the assertion that the older pupils are at a higher cognitive level. The evidence also shows that few pupils have in fact reached formal operational thinking. Many of the pupils' statements made in their project work, and the way in which they coped with the tasks set from the software, indicate operations in the transitional stage of 2B/3A category. This in itself is evidence that generally the cognitive level of the pupils is higher, as expected for their age.

The few examples chosen in the analysis has indicated that the energy network can be used for representing the older pupils conceptions and ideas of energy equally well. These representations have also appeared to reflect the pupils expected cognitive levels, as was the case with the younger pupils.

CHAPTER 9 CONCLUSIONS

9.1 INTRODUCTION

The basis of the research has been to see what effective ways can be found for incorporating computer software into teaching strategies, by looking at prior conceptions, cognitive level, and the demands of the software.

Chapter One suggested that in order to address the problems of integrating computer software into the teaching of energy, certain areas of consideration were needed:

- (a) Types of software available;
- (b) The way pupils conceived energy;
- (c) The cognitive demands of the software with respect to the cognitive levels of the pupils.

The case studies described in this research have tried to focus on these issues, by considering a specific piece of energy software CEDRIC 2.1, and have led to proposals for possible teaching strategies to ease certain difficulties. Although the work has answered some of the questions, it has brought to light several others that pose important questions for both teacher and researcher. If software is to be successfully incorporated into classroom teaching the following two questions need to be considered:

- 1 Is there a link between the structure of children's conceptions of energy and their cognitive level; how does this relate to the demands made by the software?
- 2 How can these help in making decisions about the use of the software in a given teaching scheme?

This thesis can be regarded as an exploration of these questions, and its findings suggest that there is a link between prior conceptions and cognitive level, and that this in turn reflects how pupils cope with the demands of the software.

This chapter will summarise the evidence from the investigations that support this statement, and will discuss the implications for the integration of computer software into the teaching of energy.

9.2 SUMMARY

Three areas have been discussed in this thesis:

- 1 The structure of pupils' conceptions of energy, before and after teaching, identified:
 - (a) Through an energy questionnaire;
 - (b) Through a network describing conceptions appearing in pupils' work.
- 2 The level of cognition of the pupils, and the conceptual demands of the software, by using the Shayer and Adey Science Reasoning Tasks, and the Curriculum Analysis Taxonomy respectively.
- 3 The integration of CEDRIC 2.1 into a teaching scheme.

9.3 PUPILS' CONCEPTIONS AND COGNITIVE LEVEL: IS THERE A LINK?

The difficulties and problems pupils have with the concept of energy have been well documented, [Bliss and Ogborn (1985), Brook and Driver (1984), Solomon (1983, 1987), etcl. The description of alternative conceptions has been the main focus of such writing. However the majority have focused around stating the differences between the "scientific" view and those held by the pupils. Few clues have been given to possible links between

children's alternative conceptions and their cognitive development. Chapter 7 has confirmed that pupils do have prior conceptions and has further produced evidence that there is an underlying structure to these conceptions which changes with age.

The main structure common to the younger and older pupils is a distinction between "Sources" and "Consumers" or "Users" of energy. "Sources" are things seen as ones from which we get energy, and things which ARE energy. These include foods, fuels, the sun and naturally active phenomena such as the sea, wind and water. "Consumers" are the things seen as needing energy and which use energy from other things, such as a cooker, and a bicycle and living things. The major difference between the younger and older pupils was the way the loss of energy was considered; the older pupils associating losing energy with being a user of energy whereas the younger pupils associated it with loss of activity. This division and association can be considered through stages of development.

What is being suggested here is that the difference in the way energy is conceptualised by the two groups can be linked to the cognitive level of the pupils. In this study the pupils, from ages 10 to 14 years, had cognitive levels ranging from 2A/2B to 3A/3B. Examination of these developmental stages, through the Shayer Taxonomy, indicated what can be expected of pupils in this age range. A pupil at 2A/2B would be expected to relate energy concepts such as power and work in an intuitive and anthropomorphic way, whereas a pupil at 3A/3B would be expected to relate energy concepts such as power to work done, and to be

able to appreciate different forms of energy having capacity (extensive) and potential (intensive) aspects.

This latter aspect of the taxonomy was found to be problematic as its main emphasis in differentiating forms of reasoning was directly related to extensive and intensive aspects of energy, which the older pupils showed no signs of. However when considering the way the older pupils reasoned, with respect to the taxonomy a better association was found. The variation in cognitive level between the younger and older pupils appeared to fit well with the structure found for respective pupils conceptions of energy.

The link between cognitive level and prior conceptions is clarified when detailed differences between the two groups of pupils are studied. This analysis suggests that the older pupils are less inclined to a simple explanation that energy is equated to activity. Evidence has been given to support the view that the older pupils are thinking of energy in terms of something that is exchangeable between objects, so that objects could be both a source or a user; this fits well with higher level thinking.

9.4 COGNITIVE LEVEL AND CONCEPTUAL DEMAND: IS THERE A LINK?

The cognitive demands of the software tasks have been examined, and appear in certain areas to be greater than those appropriate to the average 10 to 13 year old pupil. These difficulties became apparent in their work. Analysing the tasks set from the software, by using the Shayer and Adey approach, has highlighted areas that the pupils find difficult, suggesting, excluding or simplifying certain tasks.

The results of such modifications suggest that the main problem of using the software stemmed from its task documentation, the nature and content of which was beyond the average primary pupil, rather than from the underlying cognitive demand. This work can therefore be viewed in part as a trial of the Shayer approach. Since the taxonomy does seem to isolate many of the concepts which are found to give rise to difficulties for the pupils, this study suggests that the Shayer approach provides a useful tool for Teacher/Researcher engaged in software analysis for science teaching.

9.5 TEACHING AND LEARNING ENERGY

Learning is considered active, not passive, by involving the children directly in their learning, whether it be with computer interaction or information finding and recording. This has very much been the case in the present project. The assertion however, presupposes a dual role for the teacher:

- (a) That of giving the learner sufficient and appropriate information and instruction, so that interaction with each task set can be accomplished;
- (b) In order to help the pupils construct meaning, the teacher must be aware of the cognitive level that the pupil is working at as well as understanding some of the pupils' basic notions about energy. Within the present research, learning has been viewed as a qualitative change in a pupils' conceptions of energy, and energy related concepts. It represents a distinct change in how energy is perceived, understood and in the meaning it then has for the learner.

Changes from one conception to another do occur, mainly (one can argue) because conflict between the differing ways of thinking becomes explicit through the teaching strategy chosen. The research has shown, if only tentatively, that it is possible to describe pupils' prior conceptions and then to describe the

changes that have taken place in those conceptions. A conception is taken to be a way of seeing something, a qualitative relationship between an individual and some phenomena, in this case to do with energy. That is, conceptions are categories of interpretation in terms of which pupils understand the world around them. From this standpoint it has been possible to show a change in the way pupils conceptualise energy, which may in part be due to the teaching strategy chosen, although this cannot be certain.

The analysis of the energy questionnaire after teaching indicated a distinctive change in the way energy was viewed by the younger pupils, as well as for the older pupils, albeit to a lesser extent. The decrease in importance of the second dimension, for the younger pupils, which related energy to "action", would seem to suggest that they were viewing energy differently. However, examining the first dimension it was apparent that the "source/consumer" view of energy remained strongly. In the case of the older pupils, the second dimension although weak prior to teaching had almost disappeared completely afterwards. If these interpretations can be taken as indicating change in the way pupils perceive energy, then it would be possible to say that the teaching strategy chosen was effective in some way.

There are no guarantees that a specific piece of software can help the teacher achieve these aims at the present time. However, what is proposed here is that within certain topic areas, software with good well planned documentation can stimulate pupils into thinking about topics such as energy, and in this way promote learning. This leads to asking the question

"What makes an effective program for classroom use, and are there principles evolving from Educational or Instructional psychology which could underpin their design?"

From the theoretical framework and underlying assumptions of the research as discussed in Chapters 4 and 5 respectively, it would appear that the case studies carried out show the beginnings of a possible approach to teaching/learning of energy with computer software, based on modifying tasks to accommodate prior conceptions and cognitive levels of pupils, so as to reduce the conceptual demands of the material used.

9.6 FINAL COMMENTS

One of the concerns of the project was the nature of the match between the demands of the tasks or activity set by the software, with the pupils' capacity to undertake it. Analysis showed (Chapters 7 and 8) a possible connection between cognitive level, prior conceptions and pupils' potential for completing tasks successfully. More investigation is required into designing software with specific cognitive levels in mind, using a theoretical framework from Educational and Instructional psychology as suggested in Chapter 4.

With specific reference to the teaching of energy, such a design would need a fuller description of the structure of childrens' dimensions of energy than could be obtained in the present work. This would also need a larger sample of pupils, but could possibly help in future design of energy software. If such a design is possible how can it be integrated into conventional classroom teaching? Chapter 4 discussed various teaching styles and the quality of pupils' learning experiences with respect to

pupil achievement. What the present research has been able to show in the few cases examined is that software integration is complex, involving several points of consideration, such as:

- 1 Is the software appropriate?
- 2 Has the software got adequate documentation?
- 3 Does it match the cognitive level of the pupils?
- 4 How easy is it to use?

It is not necessary here to discuss these points again, however what is required is to indicate that these simple questions have greater underlying importance for successful integration than at first meets the eye. What is required is further in-depth studies with other pieces of software to see if integration can be achieved within a well constructed framework of teaching strategies, prior conceptions and cognitive level.

The research has only considered one very small aspect of science teaching, albeit a complex and often difficult area to teach, Energy. Its complexity stems from the difference between social explanations of energy and its scientific definition, these two notions often seeming to be in conflict with each other. Energy, however, is not the only area of the curriculum that faces this type of problem. Mechanics has also shown these problem areas. What is being suggested here is that it would be interesting to see if the approach outlined in the present project can be used for other areas of the science curriculum.

What I believe has been achieved through the research is that carefully constructed documentation that takes account of the cognitive level of pupils as well as their preconceptions, has

enabled a piece of computer software such as CEDRIC 2.1 to be used successfully with a wide range of pupils. The research has also shown that the energy questionnaire is a simple but effective tool that enables a teacher to find the pupils' conceptions of energy, and the development of the energy network appears to be able to characterise pupils' notions of energy for all age ranges. I also believe that the research has given indications that the quality of pupils' learning experiences with respect to their achievement can be explored through the use of computer software.

In conclusion it can be said that the use of CEDRIC 2.1 within an integrated teaching strategy has a considerable amount to offer teachers within the context of energy. However teachers must consider seriously the type of pupil with whom they will be attempting to use the software, and in what way they can reconcile the idea of prior conceptions with the philosophy of cognitive development as presented in the Shayer Taxonomy.

BIBLIOGRAPHY

- ADEY P, BLISS J, SHAYER M (1989). Adolescent Development and School Science. Falmer Press.
- ANDERSON S B, BALL S (1978). The Profession and Practice of Program Education. Jossey - Bass Publications.
- ARCHENHOLD W F, DRIVER R, ORTON A, WOOD-ROBINSON C (1979). Cognitive Development, Research in Science and Mathematics, University of Leeds Publication.
- AUSUBLE D (1968). Educational Psychology. A Cognitive View. Holt, Rinehart and Winston.
- AUSUBLE D (1973). Meaningful Reception Learning and the Acquisition of Concepts.
- AUSUBLE D, NOVAK J D, HANESIAN H (1978). Educational Psychology, a Cognitive View. Holt Publications, 2nd Edition.
- BARKER P, YEATES H (1985). Introducing Computer Assisted Learning. Prentice Hall International.
- BARNES D (1976). From Communication to Curriculum. Penguin Books.
- BELL B F (1985). The Construction of Meaning and Conceptual Change in Classroom Settings. University of Leeds.
- BENNETT N, DESFORGES C, COCKBURN A, WILKINSON B (1986). The Quality of Pupils Learning Experiences. LEA Publications.
- BENNETT N (1976). Teaching Styles and Pupils Progress. The Chaucer Press Ltd.
- BENTLEY D, WATTS M (1989). Learning and Teaching in School Science, Practical Alternatives. OU Press Milton Keynes.
- BERK R A, (Ed) (1981). Education Methodology, The State of The Art. University Press.
- BIGGS J (1979). Individual Differences in Study Processes and the Quality of Learning Outcomes. In Higher Education 8 (1979) pp381-384.
- BLACK P, SOLOMON J (1983). Life World and Science World - pupils ideas about energy. Entropy in the School Volume One, Roland Eotvos, Physical Society.
- BLEASE D (1986). Evaluating Educational Software. Croom Helm.
- BROOK A, DRIVER R, JOHNSTON K (1989). Learning Processes in Science: A Classroom Perspective. In Science and Education, Ed by Wellington J.
- BROOK A, DRIVER R (1984). Aspects of Secondary Students Understanding of Energy. A Full Report. University of Leeds. (CLISP).

- BROWN G, DESFORGES C (1977). Piagetian Psychology and Education, Time for Revision. In British Journal of Educational Psychology. Vol.47 pp7-17.
- BRUNER J S (1969). Studies in Cognitive Growth. Chichester Wiley.
- BRUNER J S (1973). Beyond the Information Given. Allen and Unwin.
- CARY S (1986). Cognitive Science and Science Education. American Psychologist 41. 1, pp123-130.
- CARY S (1987). Conceptual Change in Childhood. MIT Press.
- CEDRIC 2.1 (1987). Community Energy Display and Retrieval of Information. British Gas.
- CHILDRENS LEARNING IN SCIENCE PROJECT (1985): Energy;
A Constructivist Approach for Secondary schools Students.
University of Leeds.
- CLAXTON G (Ed) (1980). Cognitive Psychology. Routledge and Kegan Paul.
- CLAXTON G (1984). An Introduction to the Psychology of Growth and Change in Everyday Life. OU Press.
- CLEMENTS D H (1985). Computers in Early and Primary Education. Prentice Hall.
- COTTON J W (1978). Semantic Factors in Cognition. LEA Publications.
- DELG'INNOCENTI R, FERRARIS M (1988). Databases as a Tool for Promoting Research Activities in the Classroom. In Computer Education Vol. 12, No. 1 pp157-162.
- DESFORGES C, BROWN G (1979). The Educational Utility of Piaget. A Reply to Shayer. British Journal of Educational Psychology Vol. 49 pp277-281.
- DRIVER R (1973). The Representation of Conceptual Frameworks in Young Adolescent Science Students. Unpublished Doctoral Dissertation University of Illinois.
- DRIVER R (1982). Making a Match? A Review of the CSMS Science Reasoning Tasks. In European Journal of Science Education Vol. 4 pp123-127.
- DRIVER R (1989). Students Conceptions of the Learning of Science. International Journal of Science Education Vol. 11, No. 5 pp481-491
- DRIVER R (1983). The Pupil as Scientist? OU Press.
- DRIVER R, BELL B (1986). Students Thinking and Learning of Science. A Constructivists View. School Science Review 67. 240 pp443-456.
- DRIVER R, GUESNE E, TIBERGHIE A (1985). Children's Ideas in Science. Open University Press.
- DRIVER R, MILLAR R (Ed) (1986). Energy Matters. University of Leeds.

- DRIVER R, OLDHAM (1986). A Constructivist Approach to Curriculum Development in Science Education. Studies in Science Education 13. pp105-122.
- DRIVER R (1989). Learning Processes in Science Education: A Classroom Perspective, In Science Education, A Critical Analysis Ed. WELLINGTON J.
- DUIT R (1981). Students notions about Energy concepts - before and after Physics instruction. In Jung w. Pfundt H, Rhoneck C.V. Problems Concerning Students Representations of Physic and Chemistry knowledge.
- DUNN S, MORGAN V (1987). The Impact of the Computer on Education. (A Course for Teachers). Prentice Hall.
- EDWARDS D, MERCER N (1987). Common Knowledge. Open University Press.
- ENGEL-CLOUGH E, DRIVER R (1986). Consistency in the use of Students Conceptual Frameworks Across Different Tasks Contexts. Science Education 70. 4. pp473-496.
- ENTWISTLE N (1981). Styles of Learning and Teaching. John Wiley and Sons.
- ENTWISTLE N (1987). Understanding Classroom Learning. Hodder and Stoughton.
- FLAVELL J H (1977). Cognitive Development. Prentice Hall.
- GILBERT J, POPE M (1982). School children discussing energy. Institution of Educational Development, University of Surrey.
- HEAD J (1986). Research into "Alternative Frameworks Promise and Problems". In User Central System Design Ed. NORMAN D A, DRAPER S W, LEA Publications.
- HEAD J (1982). "What can Psychology Contribute to Science Education?" School Science Review Vol. 63 pp631-642.
- HARTLEY J R (1988). Learning from Computer Based Learning in Science. Studies in Science Education Vol. 15 pp55-76.
- HARTLEY J R (1985). Using the Computer for Learning and Teaching. In New Directions in Educational Psychology Ed. ENTWISTLE N. Falmer Press.
- HOWE J A, ROSS P M (1981). Microcomputers in Secondary Education, Issues and Techniques. Kogan Page.
- INGLE R B, SHAYER M (1971). Conceptual Demands in Nuffield 'O' Level Chemistry. Education in Chemistry Vol. 8 pp182-183.
- JOHANSSON B, MARTON F, SVENSSON L (1985). "An Approach to Describing Learning as Change Between Qualitatively Different Conceptions. In Cognitive Structure and Conceptual Change. Academic Press pp233-257.
- KELLY A V (1984). Microcomputers and the Curriculum. Harper Row.

- KELLY (1956) REPRINT (1965). The Psychology of Personal Constructs. New York; Norton.
- KEMMIS S, ATKIN R, WRIGHT E (1977). How do Students Learn? Occasional Paper 5, University of East Anglia, Centre of Applied Research in Education.
- KIRBY J, BRIGGS J (1980). Cognitive Development and Instruction. Academic Press.
- KLAUSMEIER H J, ALLEN P S (1978). Cognitive Development of Children and Youth. A Longitudinal Study. Chapter 2 pp30. Academic Press.
- KLAUSMEIER H (1980). Learning and Teaching Concepts. Academic Press.
- KLAUSMEIER H, SIPPLE T S (1982). "Factor Structures of the Piagetian Stages of Concrete operations." Contemporary Educational psychology Vol. 7 pp161-180.
- KUHN K, AGUIRRE J (1987). A Case study - on the journal - a method designed to enable the implimentation of constructivist teaching in the classroom, in NOVAK J (Ed) Proceedings of the Second International Seminar: Misconceptions and Educational Strategies in Science and Mathematics. Vol. 2 pp262-274.
- KUHN D, AMSEL E, O'LOUGHLIN M (1988). The Development of Scientific Thinking Skills. Academic Press.
- LAWSON A E (1982). The Reality of General Cognitive Operations. Science Education Vol. 66 pp229-241.
- LAWSON A E, SNITGEN D A (1982). Teaching Formal Reasoning in College Level Biology Course for Perservice Teachers. Journal of Science Teaching Vol. 19 pp233-248.
- LEWIS R, TAGG E D (Ed) (1981). Computers in Education. North-Holland Publishing Company.
- LIBEN L S (Ed) (1987). Development and Learning, Conflict or Congruence? LEA Publications.
- LOVELL K, SHAYER M (1978). The Impact of the Work of Piaget on Science Curriculum Development. Knowledge and Development Vol. 2 Piaget and Education. Plenum Press.
- MADDISON A (1982). Microcomputers in the Classroom. Hodder and Stoughton.
- MADDISON J (1983). Education in the Micro-electronics Era. The Open University Press.
- MAGOON A J (1977). Constructivist Approaches in Educational Research. Review of Educational Research 47, pp651-693.
- MARTON F, HOUNSELL D, ENTWISTLE N (1984). The Experience of Learning. Scottish Academic Press.
- MILLAR R (1989). Constructive Criticisms. International Journal of Science Education Vol. 11, No5 pp587-596.

- NASH A, BALL D (1982). An Introduction to Microcomputers in Teaching. Hutchingson & Company Ltd.
- NEISSER U (1976). Cognition and Reality. Freeman Company.
- NORMAN D (1978). Towards a Complex Theory of Learning. In Cognitive Psychology and Instruction, Ed. LESGOLD A. PELLEGRINO Plenum Press.
- NORMAN D (1982). Learning and Memory. Freeman Company.
- NORMAN D, RUMELHART D (1975). Explorations in Cognition. Freeman and Company.
- NOVAK J, GOWIN D (1984). Learning how to Learn. Cambridge University Press.
- OSBORNE J, BELL B, GILBERT J K (1983). Science Teaching and Children's views of the World. European Journal of Science Education Vol. 5. 1, pp1-14.
- OSBORNE R, FREYBERG P (1985). Learning Science: The Implications of Children's Science. London Hieneman.
- OSBORNE R J, WITTRUCK M C (1983). A Generative Process. Science Education 67.4. pp489-508.
- O'SHEA T (1979). Self-Improving Teaching Systems: Basel, Birkhauser Verlag.
- O'SHEA T, SELF J (1987). Learning and Teaching with Computers. The Harvest Press.
- PAPERT S (1980). Mindstorms. Harvester Press.
- PASCUAL-LEONE J (1980). A Mathematical Model for the Transition rule in Piaget's developmental stages. Acta Psychology 32, pp301-345.
- PEG (1986). Primary Energy Game. British Gas.
- PIAGET J (1974). Success and Understanding. Routledge and Kegan Paul.
- PIAGET J (1975). The Development of Thought Equilibration of Cognitive Structures. Blackwell.
- PIAGET J, INHELDER B (1966). The Growth of Logical Thinking. Routledge and Kegan Paul.
- PIAGET J, INHELDER B. The Psychology of the Child. Routledge and Kegan Paul.
- PIAGET J, INHELDER B (1974). The Childs Constructs of Quantities. Routledge and Kegan Paul.
- POPE M, GILBERT J K (1985). Theories of Learning: KELLY: In Osborne R J and Gilbert J K (Eds), Some issues of Theory in Science Education. University of Waikato.

- REID I, RUSHTON J (1985). Teachers, Computers, and the Classroom. Manchester University Press.
- ROWELL J (1984). Many Paths to Knowledge, Piaget and Science Education Studies in Science Education Vol. 11 pp1-25.
- ROWELL J A, DAWSON C J (1980). Mountain or Molehill, Can cognitive psychology reduce the dimensions of conceptual problems in classroom practise. Science Education Vol. 64 pp693-708.
- RUSHBY N (Ed) (1987). Technology Based Learning. Kogan Page.
- RUSHBY N (1981). Selected Readings in Computer Based Learning. Kogan Page.
- RUSHBY N (1979). An Introduction to Educational Computing. Croom Helm.
- RUTKOWSKA J, CROOK C (Eds) (1987). Computers, Cognition and Development. Wiley and Sons Ltd.
- SCANLON E, O'SHEA T (1987). Educational Computing. Wiley and Sons.
- SCHUTZ A, LUCKMAN T (1973). Structures of the Life World. Heinemann Publications.
- SELF J (1985). Microcomputers in Education. Harvester Press.
- SEGAL J W, CHIPMAN S F, GLASER R (1985). Thinking and Learning Skills Vol. One Relating Instructions to Research. LEA Publications.
- SIEGLER R S (1978). Children's Thinking What Develops? LEA Publications.
- SHAYER M (1979). Has Piaget's Constructs of Formal Operational Thinking and Utility. British Journal of Educational Psychology Vol. 49.
- SHAYER M (1978). The match of Science Curriculum to Learner in the middle and secondary school. Studies in Science Education Vol.
- SHAYER M (1978). The Analysis of Science Curriculum for Piagetian level of demand. Studies in Science Education Vol. 5 pp115-130.
- SLOAN D (1984). The Computer in Education. A Critical Perspective. Teacher College Press.
- SOLOMON C (1987). Computer Environments for Children. A Reflection on Theories of Learning and Education. MIT Press.
- SOLOMON J (1983). Messy, Contradictory and Obstinate Persistent: a study of children's out-of-school ideas about energy. School Science Review 65 pp225-233.
- SOLOMON J (1983). Learning about Energy: How children think in two domains. European Journal of Science Education. Vol. 5 (1) pp49-59.
- SOLOMON J (1987). Social Influences on the construction of pupils understanding of science. Studies in Science Education. Vol. 14 pp63-82.

- SOLOMON J (1984). Children's Explanations. Paper presented at AERA Conference.
- STEAD B (1980). Energy. Working Paper 17. Learning in Science Project. University of Waitato.
- STEINBERG E R (1984). Teaching Computers to Teach. LEA Publications.
- STRAUSS S (1987). Psychology and School Learning. Development and Learning Conflict or Congruence. LEA Publications. pp133-157.
- STRIKE K A, POSNER G J (1982). Conceptual Change and Science Teaching. European Journal of Science Education. Vol. 4 (3) pp231-240.
- SUPPES P, MORNINGSTAR M (1966). Computer Assisted Instruction. Science 166 pp343-350.
- TOMLINSON P (1981). Understanding Teaching. McGraw-Hill. UK.
- UNDERWOOD G, BRIGGS P (1984). The Development of word recognition processes. British Journal of Psychology Vol. 75 pp243-255.
- VYGOTSKY L S (1962). Thought and Language. Cambridge MA MIT Press.
- VYGOTSKY L S (1978). Mind in Society: The development of higher psychological processes. Cambridge MA: Havard University Press.
- WALKER D (1983). Reflections on the Educational potential and limitations of microcomputers. Report: Stanford School of Education. Stanford University USA.
- WALLACE J G (1972). Stages and Transition in Conceptual Development. An exploritory study. NFER.
- WATSON D (1987). Developing CAL. Computers in the Curriculum. Narper Educational Series.
- WATTS D M (1983). Some Alternative Views of Energy. Physics Education. Vol. 18 pp213-217.
- WATTS D M, GILBERT J K (1983). Enigmas in School Science: students conceptions for sciectificially associated words. Research in Science and Technology Education, 1, pp161-171.
- WELLINGTON J J (1985). Children, Computers and the Curriculum. Harper Educational Press.
- WHITE C S (1987). Developing information-processing skills through structural activities with file-management programs. Journal of Education Computing Research. Vol. 3.3.
- WILLIAMS R, McCLEAN C (1985). Computing in Schools. Holmes McDougall Ltd. Edinburgh.
- YAZDANI M (1987). Artificial Intelligence, Powerful Ideas and Childrens Learning. Computers, Cognition and Development.

Appendix 1

SOFTWARE AVAILABILITY ON ENERGY AT PRESENT 1987/88

1	Energy (First projects series) Cambridge University Press*	6-9 years
2	Electric Softlab Shell Education	6+ years
3	PEG Primary Energy Gas British Gas Education Service	9-11 years
4	Heat and Temperature* Shell Softlab packages	11+ years
5	Cedric 2/2.1 Home Insulation/Energy Savings ...	11-14 years
6	Watts in Your Home Cambridge University Press	11-16 years
7	Nuclear Reactors Simulations Longmans Publications	14-18 years
8	BP Energy Pack BP Educational Services	15-18 years
9	Power Package CEGB Educational Services	15+ years
10	Domestic Heating	Secondary level
11	Micro Gas Class British Gas Education Service	5+ years

* This software was not available at 2 February 1988. Evaluation will follow in due course.

1 METHOD OF ANALYSIS USED IN COMPILING CATALOGUES

- 1 Type of Software: Make, dimensions of disc, cassette.
- 2 Program Classification: Game, simulation, graphics, database, etc.
- 3 Program User: Age, ability;
Group use or individual use;
Class orientation.
- 4 Subject Classification/Area of Curriculum to be covered:

Specific topic, general area being covered, ie if looking at energy specifically:

- (a) Energy Conservation;
- (b) Energy Use;
- (c) Energy Type;
- (d) Energy production.

(It would be useful for the teacher to be able to pinpoint area of use within the structure of the syllabus.)

5 Scope of Program:

Mode of presentation, who is involved with the computer, and who is in charge.

What does the program do?

What is its intended use?

- (a) Concept Learning.
- (b) Reinforcement.

How will the user use it?

Does it assist the teacher in what is already being taught?

External documentation - What does it include?

- (a) Statement of what program intended to do.
- (b) Flow Chart.

6 Interaction of program:

(a) Is the program flexible?

Does the pupil adapt to it or does it adapt to the pupil?

ie

(1) Computer controlling pupil.

(2) Teacher, class, and computer.

(3) Pupil controlling computer.

(4) Teacher and computer, no pupil (use for preparation of teaching material).

(b) Does it leave the initiative with the user?

(c) Does it offer options, ie

(1) Does it make clear what these options are?

(2) What are the implications of adopting them?

(d) What mode does it operate?

(1) Command.

(2) Tutorial.

(3) Menus.

(4) Keywords.

(5) Mouse icon system.

(e) Is there an easy backtrack?

7 Overall Impressions:

2 SHELL SOFTLAB: ELECTRICITY

- 1 Shell publication: Kings College 1987: BBC 40/80 track Disc Econet.
- 2 Provides simulations of experiments.
- 3 User ability 11-13 age group) Usage with small groups package also intended for 6+) and individuals.
- 4 Electricity and its uses:
 - (a) Starting with Circuits;
 - (b) General Circuits;
 - (c) Circuits using symbols;
 - (d) Batteries;
 - (e) Milk float;
 - (f) Electricity at home;
 - (g) Information menu file.

Good supplementary information for teacher, hence can pinpoint exact use of program for areas of Curriculum intended.

5 Operation Mode includes:

- (a) Menus, Commands and Simulations;
- (b) Program looks at all areas of basic Electrical Circuits and simple ideas of Electrical energy use, ie in the home;
- (c) Intended use, to enable pupils to encounter electrical principles and applications in an easy way;
- (d) User is always active and has ability to set up circuits and correct where errors are made;
- (e) Possible uses for teachers are to give pupils more experience with electrical circuits when time and equipment might not be available;
- (f) External documentation is good, well illustrated and presented. Teachers notes are extensive in use of package.

6 Impressions:

The program is flexible, as a pupil can operate it easily, as simple commands are followed. Options given are clearly stated and easy to follow. Good interaction between pupil and program. No easy backtrack, but results easily obtained by pressing F1 key.

3 PRIMARY ENERGY GAME: BRITISH GAS EDUCATIONAL SERVICE

1 British Gas Publications: Institute of Education 1986 40/80 Track disk, BBC, RML.

2 Provides a simulation type game.

3 User ability 9+ years - best used individually, although small groups could work on it.

4 Attempts to show how a house can be kept warm through PEG, a working thermostat. Points are awarded for correct use of doors, windows, etc so that energy is conserved. Scope for teacher use is very limited.

5 Operation Mode:

(a) Drill in game code;

(b) Program tries to introduce ideas of energy conservation through maintaining constant temperature throughout the house;

(c) Intended use, for pupils to gain awareness of energy loss and conservation, as pupil is interacting at all times with program;

(d) Teachers need to familiarize themselves with program first before deciding how to use program;

(e) External documentation limited, no guidelines as for real use in curriculum.

6 Interaction of program:

(a) Pupil has to adapt to program;

(b) Computer controls program;

(c) Direction keys have to be used continually to score;

(d) Initiative of use left to pupil.

7 Impressions:

Not a very flexible program with no immediate apparent directional use. Aim to reach 2000 points.

4 BRITISH GAS: CEDRIC 2

- 1 British Gas Education Service 1985 for BBC B 40/80 Track disk, RML 480Z.
- 2 Provides database statistics, and graphics.
- 3 User ability 14+ years with variety of uses in the curriculum, age dependant on how and to what level it is going to be used.
- 4 Program gives pupils data that can then be compared with various equivalent data collected by pupils in an effort to put across the ideas of energy conservation. It has special relevance to home insulation, and efficient use of energy within home context.

Uses are diverse as program is flexible. Teacher would have to assess particular needs for each area of the curriculum, use was intended for.

- 5 Mode of operations include:
 - (a) Commands, menus;
 - (b) Gives data for regional areas for comparison with group findings of pupils data which can be stored.
Data to be found includes -
 - (i) type of heating;
 - (ii) type of property;
 - (iii) type of insulation etc.
 - (c) Intended use, fact and data collections for analysis;
 - (d) More for group project than individual use;
 - (e) Very useful for teacher in project work as all data collected can be stored;
 - (f) External documentation include teachers handbook; pupils guide and Household Data form.

Useful indications given on how to use package as well as what can be achieved by it.

- 6 Interaction of program:
 - (1) Program adapts to pupil as information is fed into the computer and comparisons given;
 - (2) The teacher and pupil can control the computer as the initiative is left with them to compile data;
 - (3) Many options are given in a clear and distinctive way;
 - (4) Operates a menu, keywords system;
 - (5) Easy backtrack.

7 Impressions:

Flexible in terms of what the program is trying to do as various data can be collected and stored.

Commands easy to follow. Options clearly stated and easy to follow up. Wide variety of uses in the curriculum.

5 CEDRIC 2.1 BRITISH GAS EDUCATION SERVICES

(To be read in conjunction with Cedric 2)

Cedric 2.1 is a revised version of CEDRIC 2. It has taken into account recent fuel prices, and facilitated the data collection and usage, by putting the program onto one disc, saving the inconvenience of Cedric 2 of changing disc throughout the use of the program.

The documentation has also been updated including:

- 1 Teachers Guide: This gives a comprehensive account of the aims and objectives of the program, with information as to how some of the statistics used were derived at. Lesson notes are also included as a form of idea giving to the teacher;
- 2 Pupils Guide: This gives a detailed account of what a pupil could expect to find within the program. Explanations are given for the terminology used and direction of use of the program itself;
- 3 Household Data Form Masters: This indicates how the data can be collected and used for the program.

It is clearly present in a logical manner.

Overall Impressions:

A very useful piece of software. Very flexible, as it can be used across a wide range of curriculum projects/subjects. Cedric 2.1 could be most useful in some of the new GCSE courses. However, the program is let down by its package presentation. The Household data form although clearly presented could be larger and more dynamically presented as could the Cedric 2.1 package.

6 WATTS IN YOUR HOME: NETHERHALL SOFTWARE

- 1 Cambridge Micro Software Publications: Council for Educational Technology for the UK 1983. BBC 40 track disc, RML 380Z disc.
- 2 Provides data on various forms of domestic heating results dealt with graphically.
- 3 User ability 11 to 16+ years, nearer 16 than 11.
- 4 Program gives pupils various heating appliances and costs of running them at various settings. The data is then represented graphically, often showing 2 or 3 graphs simultaneously.
- 5 Mode of operation includes:
 - (a) Menus, keywords;
 - (b) Program looks at energy consumption;
 - (c) Intended use, to compare type and cost of energy using heating appliances;
 - (d) User has the ability to change cost of unit of energy used;
 - (e) External documentation - Teachers handbook.
 - (i) Well laid out, with ideas and suggestions on use of program.
 - (ii) Follow-up work included on areas such as fuel costs, conservation and long term projects. Documentation also includes a suggested survey for pupils to conduct, and values to use that are stored on a database.

6 Interaction:

- (a) Pupil must adapt as the menu guides use of program throughout;
- (b) Keywords used but continuous instruction for immediate use good, but documentation required for use of other keywords;
- (c) Initiative with pupil only when changing cost of units used;
- (d) Options offered are very limited;
- (e) No easy backtrack.

7 Impressions:

Program inflexible, pupil must always follow instructions. Choice of appliance limited, and graphic representations could be clear. Having 2 graphs simultaneously could be misleading. Options offered very limited. Program could only be used in a very specific way in a small area of the curriculum.

7 NUCLEAR REACTOR SIMULATIONS

- 1 Longman Publications: Computers in the Curriculum UK Atomic Energy Authority 1985. Suitable for BBC, B, B+, 128k Aries B2D RAM 40 track disc.
- 2 Provides simulation of Advanced Gas Cooled Reactor (AGCR).
- 3 User ability: At least 'A' level standard, with reservations of its use at GCSE or 16+ candidates. Individual use limited, more suitable for demonstration purposes.
- 4 Program attempts to illustrate the behaviour of an Advanced Gas Cooled Reactor, by showing the various components such as the reactor core, the boiler, and the turbines, or the system as a whole.

Each component can be investigated separately or the operation of the whole system simulated. Teachers handbook needs to be read before attempting to run program.

- 5 Operation Mode:
 - (a) Simulation, based on commands and menu choice;
 - (b) Program looks at various areas of the AGCR, with the ability of plotting 2 variable graphically eg, CO₂ level, and steam level;
 - (c) Intended use: to enable pupils to see the internal operations of an AGCR, and the components that would affect the running of the Reactor. (This is done numerically. Numbers chosen change quickly in a given time for each component);
 - (d) User is rather passive, require only to change the numerical values of each component. Interaction very limited;
 - (e) The use of this program for teachers is that of demonstration. As the program layout allows for this;
 - (f) External documentation includes:
 - 1 Teachers Booklet - Giving a brief rundown of what the program consists of, how the computer model was assimilated, and what machine requirements are;
 - 2 Students Booklet - This contains information on Nuclear fuel, Nuclear Power Reactors, and operating a Nuclear Reactor;
 - 3 Students Exercises Booklet - This gives an indication of how the program operates, using the demonstration option, using the full features of the program, and a series of Exercises which include;

- (a) Using the control rods;
- (b) Looking at reactivity;
- (c) Controlling the reactor core;
- (d) Investigating the boiler;
- (e) Producing electricity;
- (f) Learning how to operate a nuclear power station.

Overall Impressions:

Although program on its own is inflexible used as a package in an open project way, it could be a very useful package for teaching Electric energy supply, in any Physics curriculum. Presentation of work-sheets good and innovating.

8 THE BP ENERGY FILE

- 1 BP publications suitable for BBC, 40/80 T, RML 480Z, IBM PC, Nimbus.
- 2 Provides tabular and graphic detail on a database.
- 3 User ability varied, at school level at least 16+.
- 4 Energy production and uses on a comparative basis within nations and worlds - very diverse, teacher would have to study program in detail to see exactly where and how it could be used in the curriculum.
- 5 Mode of operation includes:
 - (a) Menus, commands/keywords;
 - (b) Shows various facts on energy levels and productions in the world;
 - (c) Intended use fact finding;
 - (d) Individual use, or possible very small groups of pupils;
 - (e) Assistance to teacher - minimal as explanations often needed;
 - (f) Good external documentation includes:
 - Tutors guide;
 - Set of worksheets;
 - Forecasting leaflet.
- 6 Interaction:
 - (a) Pupil must adapt;
 - (b) Menu and keywords used - There are many keywords and references. Therefore documentation must always be handy for referral;
 - (c) Options offered are limited;
 - (d) User initiative only in representation;
 - (e) No easy backtrack, referral to main menu.
- 7 Impressions:

Not a flexible program. Pupil must always adapt and continual referral to documentation to find keywords is a drawback. Vast amount of data available for use, but teacher would have to assimilate actual use for specific teaching.

9 POWER PACKAGE UNDERSTANDING ELECTRICITY SERVICE 1985

- 1 CEGB: Understanding Electricity Service 1985. BBC B, Master 40 Track disc.
- 2 Provides: Database, statistics, graphics and simulation of electricity supply.
- 3 User ability: 15+ with a variety of uses in the curriculum. The age of pupil would determine how and what way it was to be used.
- 4 The program enables the pupils/teacher to experience the problems related to supplying, running and maintaining an electricity supply system.

The main area of the program is to try and match demand with generations, with a realistic approach to storage. All forms of power generation are looked at; Oil, Nuclear etc.

When used in conjunction with the documentation, many possibilities arise, and could prove a flexible piece of software.

- 5 Mode of Operations:
 - (a) Commands and menu;
 - (b) Gives data for various power stations and allows others to be entered for comparison;
 - (c) Intended use: For trying to establish demand/generation ideas;
 - (d) More for group/project work than individual use. Very useful for teacher in terms of project work and energy ideas of 'O'/GCSE curriculums;
 - (e) External documentation is excellent. Variance of ideas put forward in 5 investigation manuals:
 - 1 Getting started;
 - 2 Investigations in Mathematics;
 - 3 Investigation in Economics;
 - 4 Investigation in Physical Science;
 - 5 Investigation in Geology and Geography.

Each package is self-explanatory with work-sheets designed to help and promote interest in power supply. Teachers manual is a comprehensive document introducing the program and its philosophy, with a detailed approach of its use both pictorially and written.

6 Interaction of program:

- (1) Pupil adapts to program. Pupil fed computer data but on command;
- (2) Pupil/teacher makes decision numerically but again directed by the computer program;
- (3) Few options, sometimes could be made clearer;
- (4) Operations Menu, Keyword command.

10 DOMESTIC HEATING: LONGMAN PUBLICATIONS

- 1 Longman publication: Kings College 1984 BBC 40/80 T.
- 2 Database and tabular graphics.
- 3 User ability at least 15+ years and group use would be better.
- 4 Domestic Heating - Uses of energy in various housing types. How and what amounts of energy are lost. Teacher would need to know program well before use within a specific area of use.
- 5 Mode of operations includes:

- (a) Menus and keywords;
- (b) Program looks at energy loss;
- (c) Intended use to collect data, to make aware areas of energy loss and how to minimise them;
- (d) User is experimenter, as has the ability to change values;
- (e) Possible use to teacher as project work on extension of ideas of conservation of energy;
- (f) External documentation limited;

(1) Handbook of use, this incorporates students leaflets A, B, C, D, Z. Leaflet Z is on keywords.

6 Interaction:

- (a) Pupil must adapt to program, computer in control;
- (b) Keywords used, but documentation needed for referral; as there are a great many to remember;
- (c) Initiative with pupil only in data collection;
- (d) Options offered are limited and not that clearly stated;
- (e) No easy backtrack.

7 Impressions:

Program inflexible, pupil must always adapt, as the program runs on a series of keywords. To produce displays, which then enables interaction with program as pupil can choose various values. However, keywords are many and referral to leaflet continually needed. Options offered are not always clearly stated. No easy backtrack.

11 MICRO GAS CLASS

- 1 Public Relations Department. 1985 British Gas North Western. Use on BBC B, Spectrum, Econet, 40T Disc.
- 2 Provides, simulation/game approach to energy - in terms of figure (gas flame called Fred).
- 3 User ability: It is aimed at primary and middle schools. Target area would be age 5+ used in groups rather than individually.
- 4 The program shows in a very simplistic way the nature of gas and its safety aspects. It falls into 3 sections:
 - (1) 'Fred flies home' - origins of natural gas;
 - (2) 'Fred plays safe' - safety in energy use;
 - (3) 'Fred beats waste' - energy conservation.

The program would be best used for group work to promote discussion, rather than individual use. The package is designed to be used either on its own or as a module in a given curriculum project.

- 5 Operational Mode:
 - (a) Menus and Keywords;
 - (b) Program looks at origins of gas, safety of gas use, and energy conservation using the idea of a friendly gas flame called Fred to show what is happening;
 - (c) Intended use: To bring energy awareness to the very young pupil by visually coming into contact with a gas flame. (A scratch card giving the smell of gas is included in the package), and the problems surrounding gas;
 - (d) User is not active as the key word or letter always prompts the actions except in the safety game, where there is pupil interaction, but instruction could be difficult to follow for pupil;
 - (e) The teacher could use this package in a project-like way, rather than on its own. To introduce pupils to the idea of gas as a form of energy.
- 6 Interaction of Pupil:
 - (a) Pupil has to adapt to program;
 - (b) Menu and Keywords;
 - (c) Initiative left with pupil in decision making;
 - (d) Options offered are limited but clear - except in safety game.

7 Overall Impressions:

The program has a great deal of potential but at a much lower age range than anticipated by the authors. It is suited to lower primary. Looking at it from that point of view, it has a great deal to offer the teacher as it is flexible enough to many options of discussion. For older pupils it is too simplistic. The documentation offered is very good with many ideas to launch project work within the school.

Cedric 2.1

Household Data Form

The information on this set of forms is from:
Name
about the house at:
Address
CEDRIC 2.1 home number:

About these forms;

Inside these forms you will find pages that contain pairs of boxes. The boxes on the left hand side of the form provide places to record various pieces of data about a dwelling. The boxes on the right show you where to insert this data when using the CEDRIC 2.1 software. Here is an example.

<p>You tick or write your answers in a box like this</p>	<p>The computer asks for the data like this</p>															
<p>Information needed</p> <table border="1"> <tr><td>Option 1</td><td><input type="checkbox"/></td></tr> <tr><td>Option 2</td><td><input type="checkbox"/></td></tr> <tr><td>Option 3</td><td><input type="checkbox"/></td></tr> <tr><td>Option 4</td><td><input type="checkbox"/></td></tr> <tr><td>Etc.</td><td><input type="checkbox"/></td></tr> <tr><td> </td><td><input type="checkbox"/></td></tr> </table> <p>The names of the programs within CEDRIC 2.1 that will require this information.</p>	Option 1	<input type="checkbox"/>	Option 2	<input type="checkbox"/>	Option 3	<input type="checkbox"/>	Option 4	<input type="checkbox"/>	Etc.	<input type="checkbox"/>		<input type="checkbox"/>	<table border="1"> <tr> <td style="text-align: center;"> CEDRIC 2.1 - PROGRAM Home Number <input type="checkbox"/> </td> </tr> <tr> <td> A question about the dwelling. Press a number next to your answer </td> </tr> <tr> <td> 1.. Option 1. 2.. Option 2. 3.. Option 3. 4.. Option 4. 5.. Etc.. 6.. 0.. Finished answering questions. </td> </tr> </table>	CEDRIC 2.1 - PROGRAM Home Number <input type="checkbox"/>	A question about the dwelling. Press a number next to your answer	1.. Option 1. 2.. Option 2. 3.. Option 3. 4.. Option 4. 5.. Etc.. 6.. 0.. Finished answering questions.
Option 1	<input type="checkbox"/>															
Option 2	<input type="checkbox"/>															
Option 3	<input type="checkbox"/>															
Option 4	<input type="checkbox"/>															
Etc.	<input type="checkbox"/>															
	<input type="checkbox"/>															
CEDRIC 2.1 - PROGRAM Home Number <input type="checkbox"/>																
A question about the dwelling. Press a number next to your answer																
1.. Option 1. 2.. Option 2. 3.. Option 3. 4.. Option 4. 5.. Etc.. 6.. 0.. Finished answering questions.																

<h2>British Gas Region</h2>	<p>CEDRIC 2.1 - GUESTIMATOR</p> <p>From which British Gas region is your sample taken?</p> <p>Press the number next to your answer</p>
<p>Look at a gas bill or in the 'phone book under gas to find this out.</p>	<ol style="list-style-type: none"> 1.. Scotland. 2.. Northern. 3.. North Western. 4.. North Eastern. 5.. East Midlands. 6.. West Midlands.
<p>This information is needed in the PROFILE and the GUESTIMATOR programs.</p>	<ol style="list-style-type: none"> 0.. See other list of regions.

Description of Dwelling

<h3>Type of dwelling</h3> <table border="1" style="width: 100%;"> <tr><td>Detached</td><td><input type="checkbox"/></td></tr> <tr><td>Semi-Detached</td><td><input type="checkbox"/></td></tr> <tr><td>Terraced</td><td><input type="checkbox"/></td></tr> <tr><td>Bungalow</td><td><input type="checkbox"/></td></tr> <tr><td>Flat or maisonette</td><td><input type="checkbox"/></td></tr> <tr><td>None of these</td><td><input type="checkbox"/></td></tr> </table>	Detached	<input type="checkbox"/>	Semi-Detached	<input type="checkbox"/>	Terraced	<input type="checkbox"/>	Bungalow	<input type="checkbox"/>	Flat or maisonette	<input type="checkbox"/>	None of these	<input type="checkbox"/>	<p>CEDRIC 2.1 - PROFILE</p> <p>Home Number <input type="checkbox"/></p> <p>What sort of home do you live in? Press a number next to your answer</p> <ol style="list-style-type: none"> 1.. Detached House. 2.. Semi-detached house. 3.. Terraced house. 4.. Bungalow. 5.. Flat / maisonette. 6.. None of these. <p>0.. Finished answering questions.</p>
Detached	<input type="checkbox"/>												
Semi-Detached	<input type="checkbox"/>												
Terraced	<input type="checkbox"/>												
Bungalow	<input type="checkbox"/>												
Flat or maisonette	<input type="checkbox"/>												
None of these	<input type="checkbox"/>												
<p>This information is needed in the PROFILE program.</p>													

<h3>Age of dwelling</h3> <table border="1" style="width: 100%;"> <tr><td>Pre 1914</td><td><input type="checkbox"/></td></tr> <tr><td>1914 - 1939</td><td><input type="checkbox"/></td></tr> <tr><td>1940 - 1960</td><td><input type="checkbox"/></td></tr> <tr><td>1960 - now</td><td><input type="checkbox"/></td></tr> </table>	Pre 1914	<input type="checkbox"/>	1914 - 1939	<input type="checkbox"/>	1940 - 1960	<input type="checkbox"/>	1960 - now	<input type="checkbox"/>	<p>CEDRIC 2.1 - PROFILE</p> <p>Home Number <input type="checkbox"/></p> <p>How old is your home?</p> <p>Press the answer next to your answer</p> <ol style="list-style-type: none"> 1.. Pre 1914. 2.. 1914 - 1939. 3.. 1940 - 1959. 4.. 1960 - now. <p>0.. Finished answering questions.</p>
Pre 1914	<input type="checkbox"/>								
1914 - 1939	<input type="checkbox"/>								
1940 - 1960	<input type="checkbox"/>								
1960 - now	<input type="checkbox"/>								
<p>NB if your family does not know try asking a neighbour.</p>									
<p>This information is needed in the PROFILE program.</p>									

House area calculation

If the dwelling is a basic rectangle - easy. Measure the outside wall lengths and multiply them together:

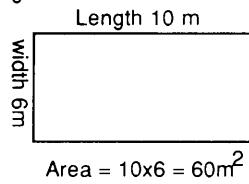

If the dwelling is a complicated shape - draw it on a separate sheet and split it into separate rectangles. Take measurements for each rectangle -

find each area and add them all together. For example:

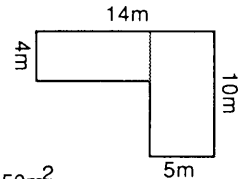

$$\text{Area 1} = 10 \times 5 = 50\text{m}^2$$

$$\text{Area 2} = (14-5) \times 4 = 36\text{m}^2$$

$$\text{Total area} = 50\text{m}^2 + 36\text{m}^2 = 86\text{m}^2$$

Size of Dwelling

Floor area

Width	Length	Area

Take the external measurements unless the dwelling is a flat - in this case you should take the internal measurements.

Roof area

Width	Length	Area

This means the area of the ceilings on the top floor - usually the same as the ground floor area. Not needed for middle flats.

Height of each floor & total

Ground		

Total height m

Total wall area m^2

Volume of house m^3

This information is needed in the DHL program.

CEDRIC 2.1 - DHL

What is the total area of your ground floor (if any)?

Just press RETURN if you have no ground floor.

Floor area
(in square metres)

CEDRIC 2.1 - DHL

What is the total area of your external walls?

Including windows and doors

Wall area
(in square metres)

Windows

Is there any double glazing ?

Yes No

This information is needed for DHL & PROFILE .

- Notes:
- Enter areas in whole square metres only.
 - Do-it-yourself secondary glazing -this should be described by the construction of the outer window.
 - Type-this describes the frame adjacent to the glass. NB plastic frames-class as wood.
 - Thermal break-some metal single and double glazed, framed windows have a plastic insert between the glass and frame.

CEDRIC 21 - PROFILE

Home number
Do you have any double glazing
Press the number next to your answer

- 1 .. Some.
2 .. None.

0 .. Finished answering questions.

CEDRIC 21 - DHL

How much of your window area is single glazed with a wooden frame?

Just press RETURN if you have none.

Area
(in square metres)

Types and areas

S/G - single glazed D/G - double glazed
T/B - thermal break

Window number	Height (m) including frame	Width (m) including frame	Wooden frame S/G	Wooden frame D/G	Metal frame S/G	Metal frame D/G	Metal frame S/G-T/B	Metal frame D/G-T/B
1								
2								
3								
4								
5								
6								
7								
8								
9								
10								
11								
12								
13								
14								
15								
Total areas in m ²								

Walls		CEDRIC 21 - PROFILE
Are the walls insulated ?		
Yes	No	
This information is needed in the PROFILE program.		Home number <input type="checkbox"/> Are your walls insulated? Press the number next to your answer 1 .. They are insulated. 2 .. They are not insulated. 0 .. Finished answering questions.

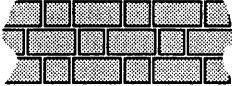
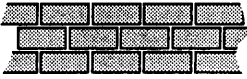
Types of external wall	
Solid brick walls are usually 9" thick - you may be able to check this at a door or window opening. The brick pattern often looks like this.	
Cavity brick walls usually look like this.	
Other types of walls: Stone and concrete walls - treat as solid brick. Timber framed - treat as 'cavity built after 1976'.	
Cavity pre 1976 and cavity post 1976. In 1976 much higher insulation levels were introduced for all new buildings.	

What type of external walls are there ?		CEDRIC 21 - DHL
Solid (no cavity)	<input type="checkbox"/>	
Cavity (no insulation) built before 1976	<input type="checkbox"/>	
Cavity (no insulation) built after 1976	<input type="checkbox"/>	What sort of external walls do you have. Press the number next to your answer 1 .. Solid (no cavity). 2 .. Cavity-no insulation-pre 1976. 3 .. Cavity-no insulation-post 1976. 4 .. Cavity-insulated.
Cavity with insulation	<input type="checkbox"/>	
This information is needed in the DHL program.		

<h2 style="margin: 0;">Ground floor Construction</h2> <p>Wooden joists <input type="checkbox"/></p> <p>Solid concrete <input type="checkbox"/></p> <p>This information is needed in the DHL program.</p>	<p style="text-align: center;">CEDRIC 2.1 - DHL</p> <p style="text-align: center;">Home number <input type="checkbox"/></p> <p style="text-align: center;">How is your ground floor mounted?</p> <p style="text-align: center;">Press the number next to your answer</p> <p>1 .. On joists. 2 .. Solid floor. 3 .. No ground floor.</p>
--	--

<h2 style="margin: 0;">Draughts</h2> <p>How much draft proofing is there ?</p> <p>None <input type="checkbox"/></p> <p>Some <input type="checkbox"/></p> <p>Full <input type="checkbox"/></p> <p>This information is needed in the DHL program.</p>	<p style="text-align: center;">CEDRIC 2.1 - DHL</p> <p style="text-align: center;">Home number <input type="checkbox"/></p> <p style="text-align: center;">How much draught proofing do you have?</p> <p style="text-align: center;">Press the number next to your answer</p> <p>1 .. No draught proofing. 2 .. Some draught proofing. 3 .. Full draught proofing.</p>
---	---

<h2 style="margin: 0;">Loft insulation</h2> <p>Is the loft insulated ?</p> <p>Yes <input type="checkbox"/> No <input type="checkbox"/></p> <p>What sort of roof do you have ? <input type="checkbox"/></p> <p>This information is needed in the PROFILE program.</p> <p>How much roof insulation is there in the roof ?</p> <p>No insulation pre 1976 <input type="checkbox"/></p> <p>No insulation post 1976 <input type="checkbox"/></p> <p>Insulated to 60 mm <input type="checkbox"/></p> <p>Insulated to 80 mm <input type="checkbox"/></p> <p>Insulated to 100 mm <input type="checkbox"/></p> <p>Insulated to 150 mm <input type="checkbox"/></p> <p>Insulated to 200 mm <input type="checkbox"/></p> <p>No roof <input type="checkbox"/></p> <p>This information is needed in the DHL program.</p>	<p style="text-align: center;">CEDRIC 2.1 - PROFILE</p> <p style="text-align: center;">Home number <input type="checkbox"/></p> <p style="text-align: center;">Is the loft insulated?</p> <p style="text-align: center;">Press the number next to your answer</p> <p>1 .. My loft is insulated. 2 .. My loft is not insulated.</p> <p>0 .. Finished answering questions</p> <p style="text-align: center;">CEDRIC 2.1 - DHL</p> <p style="text-align: center;">Home number <input type="checkbox"/></p> <p style="text-align: center;">What sort of roof do you have?</p> <p style="text-align: center;">Press the number next to your answer</p> <p>1 .. No insulation pre 1976. 2 .. No insulation post 1976. 3 .. Insulated - 60mm. 4 .. Insulated - 80mm. 5 .. Insulated - 100mm. 6 .. Insulated - 150mm. 7 .. Insulated - 200mm. 8 .. No roof.</p>
--	---

Space heating

How is the dwelling heated?

Gas fire	<input type="checkbox"/>
Electric heater	<input type="checkbox"/>
Solid fuel fire	<input type="checkbox"/>
Central heating only	<input type="checkbox"/>
C/h and gas fire	<input type="checkbox"/>
C/h and electric fire	<input type="checkbox"/>
C/h and solid fuel	<input type="checkbox"/>
Other methods	<input type="checkbox"/>

This information is needed in the PROFILE program.

If there is central heating, what fuel is used ?

Gas	<input type="checkbox"/>
Electricity	<input type="checkbox"/>
Solid fuel	<input type="checkbox"/>
Oil	<input type="checkbox"/>
Communal	<input type="checkbox"/>
None	<input type="checkbox"/>

NB. For GUESTIMATOR, class communal heating as electric. In both PROFILE and GUESTIMATOR class LPG as electric.

This information is needed in the GUESTIMATOR and PROFILE programs.

If there is no central heating how is the main living room heated ?

Gas	<input type="checkbox"/>
Electricity	<input type="checkbox"/>
Bottled gas	<input type="checkbox"/>
House coal	<input type="checkbox"/>
Smokeless fuel	<input type="checkbox"/>

How many electric storage radiators are there ?

How many gas wall heaters are there ?

This information is needed in GUESTIMATOR.

CEDRIC 2.1 - PROFILE

Home Number

Other than central heating, how do you heat your home?

Press a number next to your answer

- 1 .. Gas fire.
- 2 .. Electric heater.
- 3 .. Solid fuel fire.
- 4 .. C.H. only.
- 5 .. C.H. and gas fire.
- 6 .. C.H. and electric fire.
- 7 .. C.H. and solid fuel.
- 8 .. Other methods.
- 0 .. Finished answering questions.

CEDRIC 2.1 - PROFILE

Home Number

How is your central heating powered?

Press a number next to your answer

- 1 .. Gas.
- 2 .. Electricity.
- 3 .. Solid fuel.
- 4 .. Oil.
- 5 .. Communal.
- 6 .. None.
- 0 .. Finished answering questions.

CEDRIC 2.1 - GUESTIMATOR

Which of these fuels heats your living room?

Press a number next to your answer

- 1 .. Gas.
- 2 .. Electricity.
- 3 .. Bottled Gas.
- 4 .. House Coal.
- 5 .. Smokeless Fuel.

Occupants		CEDRIC 2.1 - GUESTIMATOR
How many people live in the dwelling ? <input type="text"/>		How many people normally live in your home?
This information is needed in the GUESTIMATOR program.		Type a number between 0 and 8. Type 8 if more than 8.
Are there any children under 16 ?		Do any children under 16 live in your home.
Yes <input type="text"/>	No <input type="text"/>	Press the number next to your answer
This information is needed in the PROFILE program.		1 .. There are children under 16. 2 .. There are not children under 16. 0 .. Finished answering questions.

Water heating		CEDRIC 2.1 - GUESTIMATOR
What fuel is used ?		How is your main hot water supply heated?
Gas <input type="text"/>	<input type="text"/>	Press the number next to your answer
Electricity <input type="text"/>	<input type="text"/>	1 .. Gas. 2 .. Electricity
NB. Regard solid fuel and LPG as electricity.		
This information is needed in the GUESTIMATOR program.		
How is the water heated ?		CEDRIC 2.1 - PROFILE
From individual appliance <input type="text"/>	<input type="text"/>	Home Number <input type="text"/>
From central heating <input type="text"/>	<input type="text"/>	How is your hot water heated ?
Central heating plus individual appliances <input type="text"/>	<input type="text"/>	Press the number next to your answer
Communal supply <input type="text"/>	<input type="text"/>	1 .. Individual appliance. 2 .. Central heating. 3 .. C.H. and individual appliance. 4 .. Communal supply. 5 .. No piped hot water. 0 .. Finished answering questions.
No piped hot water <input type="text"/>	<input type="text"/>	
NB. Individual appliances: gas/electric instantaneous, solid fuel & back boilers.		
Is the hot water tank lagged ?		
Yes <input type="text"/>	No <input type="text"/>	
This information is needed in the PROFILE program.		

Cooking		CEDRIC 2.1 - GUESTIMATOR
What fuel is used for cooking ?		How is your cooker powered? Press the number next to your answer
Gas	<input type="checkbox"/>	1 .. Gas.
Electricity	<input type="checkbox"/>	2 .. Electricity.
Bottled gas	<input type="checkbox"/>	3 .. Bottled Gas.
Gas and electricity	<input type="checkbox"/>	CEDRIC 2.1 - PROFILE
None of these	<input type="checkbox"/>	Home Number <input type="checkbox"/>
NB. Regard solid fuel as electricity.		How is your cooker powered? Press the number next to your answer
This information is needed in the GUESTIMATOR and PROFILE programs.		1 .. All gas. 2 .. All electric. 3 .. Gas and electric. 4 .. None of these. 0 .. Finished answering questions.

Other appliances			CEDRIC 2.1 - GUESTIMATOR
Does the home have a :-			Do you have a fridge?
Refrigerator	<input type="checkbox"/>	<input type="checkbox"/>	Press Y or N
Fridge/freezer	<input type="checkbox"/>	<input type="checkbox"/>	
Chest freezer	<input type="checkbox"/>	<input type="checkbox"/>	CEDRIC 2.1 - GUESTIMATOR
Washing machine	<input type="checkbox"/>	<input type="checkbox"/>	Do you have a fridge / freezer?
Dishwasher	<input type="checkbox"/>	<input type="checkbox"/>	Press Y or N
Colour TV	<input type="checkbox"/>	<input type="checkbox"/>	etc....
This information is needed in GUESTIMATOR			

Annual fuel consumptions	
Gas	
Electricity	
Solid fuel	
Oil	
LPG	
Other	
It may be possible to obtain this information from old electricity, gas and other fuel bills. If this data is not readily available discuss with your teacher how it can be obtained or how an estimate can be made.	

GRID QUESTIONNAIRE 2	TYPES OF THINGS [ENTITIES]																										
	crisis	car	room	elect	light	coal	gas	oil	food	sun	wind	bicycle	cooker	glucose	dog	tree	soil	air	water	sea	moving	footballs	atoms	heat	electricity		
✓ if it is like this X if it is like this																											
Something which can <u>NEED</u> energy																											
Something which we can <u>GET</u> energy <u>FROM</u>																											
Something which can <u>USE UP</u> its own energy																											
Something which <u>USES UP</u> energy from <u>OTHER THINGS</u>																											
Something which can be a <u>STORE</u> of energy																											
Something which <u>PASSES ON</u> energy																											
Something which can <u>LOSE</u> energy.																											
Something which can <u>HAVE</u> energy																											
Something which <u>IS</u> energy.																											

Appendix 4

ENERGY QUESTIONS 1P (Primary school)

- 1 What do we mean by energy?
- 2 Where do you think energy comes from?
- 3 Name five things that you think has energy.
- 4 How do we use energy?
- 5 How can we save energy?
- 6 What sources of energy do you know?
- 7 How do we get energy?
- 8 How do we lose energy?
- 9 In our homes how do we measure how much energy we use?
- 10 What changes the amount of energy we use at home?
- 11 Do you know any names for different types of energy? If so, make a list.
- 12 How do we measure the energy we use?
- 13 How many things can you think of that you do which use energy?

QUESTIONS ON ENERGY 15 (Secondary school)

- 1 What do we mean by energy?
- 2 Where do you think energy comes from?
- 3 Name as many types of energy that you can think of.
- 4 Why do we need energy?
- 5 Where do we get our energy from?
- 6 What sources of energy do you know? List them.
- 7 What kind of energy do we use in our homes?
- 8 What kind of energy does industry use?
- 9 How do we use energy?
- 10 How do we lose energy?
- 11 How can we save energy?
- 12 How do we measure the amount of energy used in our homes?
- 13 What changes the amount of energy used in our homes?
- 14 Have you ever heard of the following? (Please list)
 - (a) Kinetic energy;
 - (b) Potential energy;
 - (c) Heat energy;
 - (d) Chemical energy;
 - (e) Electrical energy;
 - (f) Gravitational energy.
- 15 Write a sentence to explain the meaning of each type of energy that you have listed.
- 16 Give an example of each of the types of energy you have listed.
- 17 Explain what you think the conservation of energy means.
- 18 What do you understand by the terms:
 - (a) Work;
 - (b) Power.
- 19 Have (a) and (b) anything to do with energy? If yes, what is the connection?
- 20 How do we measure energy?
- 21 What governs energy consumption?

Appendix 5(a)

PRIMARY SCHOOL RESPONSES

Question 1

This should be made easier;

"It looked hard and was difficult to answer."

Question 2

Was regarded as fair and straightforward and that the question could be left as it was.

Question 3

Here it was suggested that 5 items were too many to list and that 2 or 3 would have been better. Discussing this further, the pupils gave alternative answers such as Animals, Humans and Glucose.

Question 4

The pupils agreed to leave this question as it was, which seemed very surprising as few gave a written response to the question.

Question 5

The pupils suggested making the question clearer. This reflected the fact that the responses given were frequently alternative energy sources rather than ways of saving energy.

Question 6

Although all the pupils answered the question adequately, they found the wording of the question difficult and suggested that it should be made simpler.

Questions 7, 8, 9

Posed no problems.

Question 10

Pupils indicated that the question was not clear and suggested changing it to:

"What types of things change the amount of energy used?"

Question 11

This was found to be VERY difficult and none of the pupils had any conception of kinetic or potential energy, or any scientific terminology.

Question 12

The question, "How do we measure the energy WE use?" Proved beyond all of the pupils. The answer being looked for was Calories/Joules, but none gave this even after discussing the question. Hence the whole question needed to be reconsidered.

Appendix 5 (b)

SECONDARY SCHOOL RESPONSES

Question 4

Here the wording was queried. The pupils did not like the word "WE" as they could not decide whether it meant humans or machines.

Question 12 to 16

Seemed to prove difficult with most of the pupils. Questions 12 and 13 were quoted as being very difficult and in Question 14 the terminology was found to be problematic. Some of the pupils had heard of the terms but did not know what they meant or understood them. This led to a further problem, for if they could not answer Question 14, then Questions 15 and 16 could also not be answered.

Question 17

Was attempted by very few, the actual area of study had not been covered in lesson time. However some of the pupils had an idea of the concept of the conservation of energy but the majority found it difficult.

Questions 18 and 19

Although work and power had been taught, the pupils found it difficult to express what the terms meant. One pupil did comment that if one understood work and power, the connection should be in the explanation given, therefore Questions 18 and 19 should be linked.

Questions 20 and 21

These were also found difficult by the majority and several did not understand what the questions were aimed at.

Appendix 6

CEDRIC 2.1

HOUSEHOLD DATA RECORD

Name

Address

.....

Cedric Home Number

Region

Type of Dwelling

Detached Bungalow None of These
Terraced Flat/Maisonette

Age of Dwelling

Pre 1914 1940-1960
1914-1939 1960-Now

Size of Dwelling

Floor Area

Ground First floor Second floor

Roof Area (Ceilings)

How many windows with double glazing?

Area

Without double glazing? Area

External Wall

Solid Brick Cavity +1976
Stone/Concrete -1976

Loft Insulation Yes No

Heating

Gas Fire	<input type="checkbox"/>	+CH	<input type="checkbox"/>
Electric Fire	<input type="checkbox"/>	+CH	<input type="checkbox"/>
Solid Fuel Fire	<input type="checkbox"/>	+CH	<input type="checkbox"/>
Central Heating Only	<input type="checkbox"/>	Other	<input type="checkbox"/>

Central Heating Fuel

Gas	<input type="checkbox"/>
Electricity	<input type="checkbox"/>
Solid Fuel	<input type="checkbox"/>
Oil	<input type="checkbox"/>
Communal	<input type="checkbox"/>
None	<input type="checkbox"/>

Number of people living in dwelling

Appendix 7

CEDRIC 2.1 HOUSEHOLD DATA SHEET FOR PRIMARY USE.

Name

Address

CEDRIC House no

Region

Type of House

Age of House

SIZE OF HOUSE

Number of floors

Area of floor 1

Area of floor 2

Area of floor 3

Area of ceilings

Number of windows

Area of windows

How many windows are double glazed?

How many have wooden frames?

How many have metal frames?

How many are single glazed with metal frames?

How many windows are single glazed with wooden frames?

How many people live in your house?

What type of heating do you have?

Do you have loft insulation?

How thick is your insulation?

Do you have any draft proofing?

What is your house built with?

Does your house have cavity walls?

Does your house have floor/wall insulation?

Does your house have wooden or concrete floors?

APPENDIX 8.

CEDRIC 2.1
Household Data Form
For the Primary School

Information on this sheet is from :

Name :

About the house at :

Address :

CEDRIC 2.1 home number :

What is the total area of your ground floor?

Cedric 2.1 - DHL

What is the total area of your ground floor (if any)?

Just press RETURN if you have no ground floor

Floor area
(in square metres)

How to find the total area of your ground floor

- (i) Try and measure the length of your house from the front door to the back, in metres

Length of house =

length

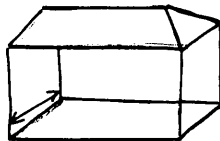

- (ii) Try to measure the width of your house from one side to the other, in metres

Width of house =

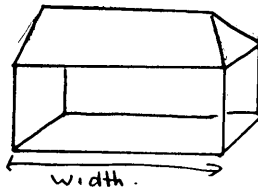

To find the area multiply

Length of house x width of house =

The answers in the RED boxes to into the computer

What is the total area of your external walls?

Cedric 2.1 - DHL

What is the total area of your external walls?

Including windows and doors

Wall area
(in square metres)

To find this out you need to measure how long and how wide the outside of your house is

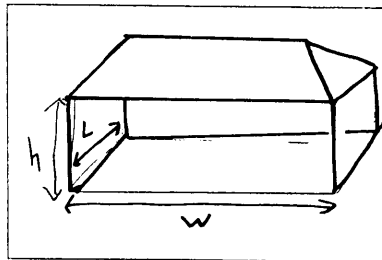

How long is your house?

How ~~wide~~^{high} is your house?

The total area of the external or outside walls are your two answers multiplied together

How long is your house x how ~~wide~~^{high} is your house

x

=

AREA OF YOUR HOUSE

What is the total volume of your house?

Cedric 2.1 - DHL

What is the total volume of your house?

Volume
(in cubic metres)

To find out the volume of your house, you have to know :

How many floors has your house got? =

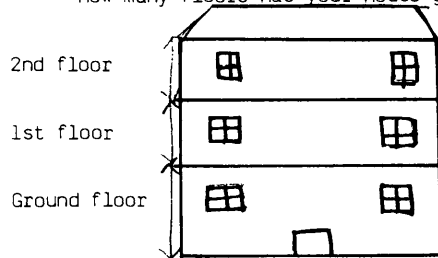

How high is the 2nd floor? =

How high is the 1st floor? =

How high is the ground floor? =

Add these numbers together.

It will tell you how high your house is =

What is the volume of your house?

Volume = Length x width x height

also

Volume = Total area x total height

You already have these answers

$$\text{Volume} = \boxed{\begin{array}{c} \text{Total} \\ \text{Area} \end{array}} \times \boxed{\begin{array}{c} \text{Height} \\ \text{of} \\ \text{House} \end{array}} = \boxed{}$$

How much of your window area is single glazed with a wooden frame?

Cedric 2.1 - DHL

How much of your window area is single glazed with a wooden frame?

Just press RETURN if you have none

Area
(in square metres)

single glazed

wooden frame

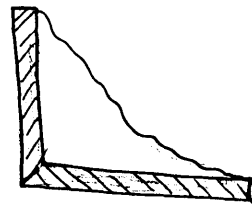

To find the area of a window

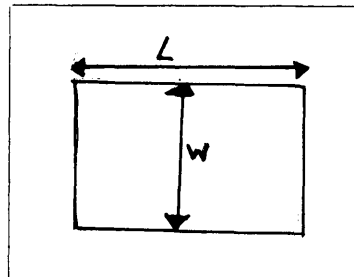

Measure the length of your window in metres

Measure the width of your window in metres

Area = Length x width
(square metres)

To find the total area of your windows

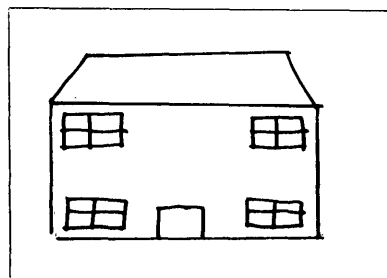

Count how many windows there are in your house =

Total Area = How many windows
x
Area of one window
=

How much of your window area is double glazed with a wooden frame?

Cedric 2.1 - DHL

How much of your window area is double glazed with a wooden frame?

Just press RETURN if you have none

Area
(in square metres)

double glazed

wooden frame

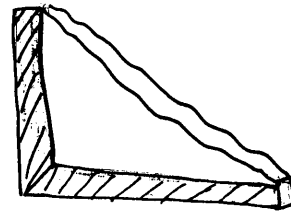

To find the area of a window

Measure the length of your window in metres



Measure the width of your window in metres



Area = Length x width
(square metres)



To find the total area of your windows

Count how many windows there are in your house =



Total Area = How many windows
x
Area of one window
=



How much of your window area is single glazed with a metal frame?

Cedric 2.1 - DHL

How much of your window area is single glazed with a metal frame?

Just press RETURN if you have none

Area
(in square metres)

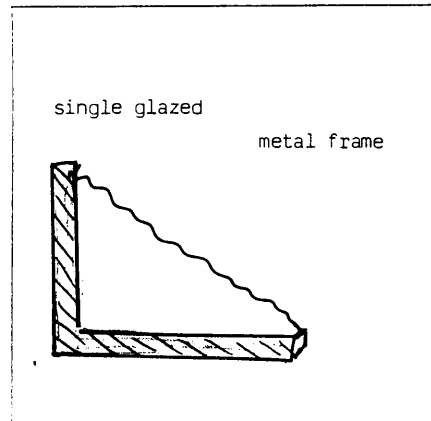

To find the area of a window

Measure the length of your window in metres

Measure the width of your window in metres

Area = Length x width
(square metres)

To find the total area of your windows

Count how many windows there are in your house =

Total Area = How many windows
x
Area of one window
=

How much of your window area is double glazed with a metal frame?

Cedric 2.1 - DHL

How much of your window area is double glazed with a metal frame?

Just press RETURN if you have none

Area
(in square metres)

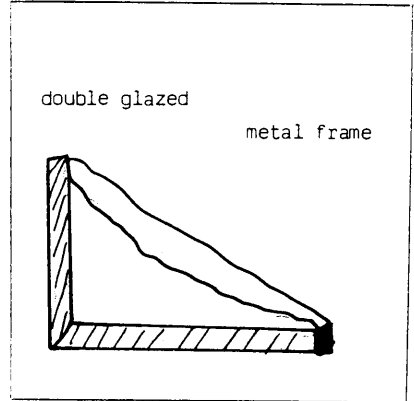

To find the area of a window

Measure the length of your window in metres



Measure the width of your window in metres

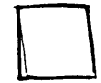

Area = Length x width
(square metres)



To find the total area of your windows

Count how many windows there are in your house =



Total Area = How many windows
x
Area of one window
=



How much of your window area is single glazed with a thermal break?

Cedric 2.1 - DHL

How much of your window area is single glazed with a thermal break?

Just press RETURN if you have none

Area
(in square metres)

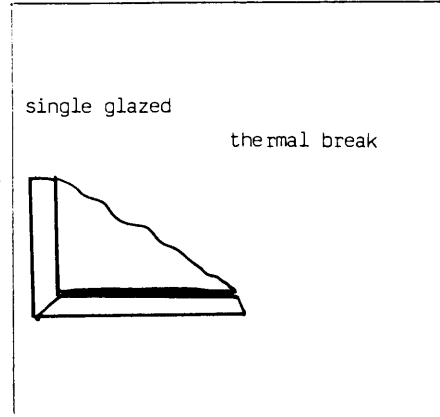

To find the area of a window

Measure the length of your window in metres

Measure the width of your window in metres

Area = Length x width
(square metres)

To find the total area of your windows

Count how many windows there are in your house =

Total Area = How many windows
x
Area of one window
=

How much of your window area is double glazed with a thermal break?

Cedric 2.1 - DHL

How much of your window area is double glazed with a thermal break?

Just press RETURN if you have none

Area
(in square metres)

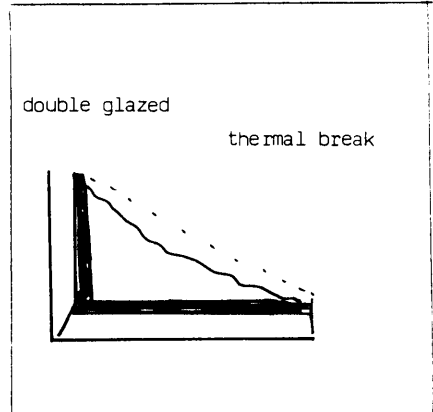

To find the area of a window

Measure the length of your window in metres



Measure the width of your window in metres



Area = Length x width
(square metres)



To find the total area of your windows

Count how many windows there are in your house =



Total Area = How many windows
x
Area of one window
=



How is your ground floor mounted?

Cedric 2.1 - DHL

How is your ground floor mounted?

Press the number next to your answer

1. On joists
2. Solid floor
3. No ground floor

Tick one of the RED boxes

1. Joists

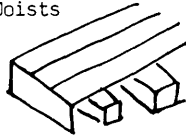

2. Solid floor

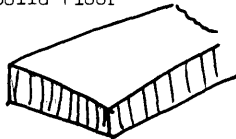

3. No ground floor



What sort of external walls do you have?

Cedric 2.1 - DHL

What sort of external walls do you have?

Press the number next to your answer

1. Solid (no cavity)
2. Cavity - no insulation pre 1976
3. Cavity - no insulation post 1976
4. Cavity insulated

This question is about how the outside walls of your house are built

Tick one of the RED boxes
The black boxes will help you answer the questions for the RED box

Are they solid brick like this?

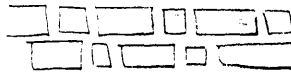

or

Are they cavity bricks like this?

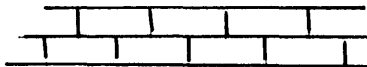

Show cavity wall insulation

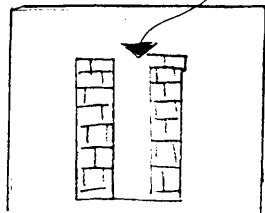

YES	
NO	

YES	
NO	

What sort of external walls do you have?

1. Solid (no cavity)	
2. Cavity - no insulation pre 1976	
3. Cavity - no insulation post 1976	
4. Cavity insulated	

How much draught proofing do you have?

Cedric 2.1 - DHL
How much draught proofing do you have?
Press the number next to your answer
1. No draught proofing
2. Some draught proofing
3. Full draught proofing

Here are some examples of draught proofing that will help you answer the questions

Door Snake	Tape around door frame	Tape around Window frame
Heavy Curtains	Secondary Glazing	etc.

How much draught proofing do you have?

1. No draught proofing	
2. Some draught proofing	
3. Full draught proofing	

What is your Home Number?

Cedric 2.1 - DHL

What is your Home Number?

Type 0 to finish

Home Number

Press RETURN

or Use DELETE to correct

Fill in your Home Number. This will help you to find your D.H.L. in the next section

Cedric 2.1 - DHL

On a cold day, if you keep your home comfortably warm, you will be losing energy to the atmosphere thus :

Roof	Kw	%
Walls	Kw	%
Windows	Kw	%
Floor	Kw	%
Gaps	Kw	%
D.H.L.	Kw	%

Please RETURN to continue

This is what you see on the screen, but there will be lots of numbers beside each item. Fill your answers from the screen in the table below.

Roof	Kw	%
Walls	Kw	%
Windows	Kw	%
Floor	Kw	%
Gaps	Kw	%
D.H.L.	Kw	%

Using the Numbers from your D.H.L. chart, fill in the gaps in the diagram with how much heat is lost through each part of the house.

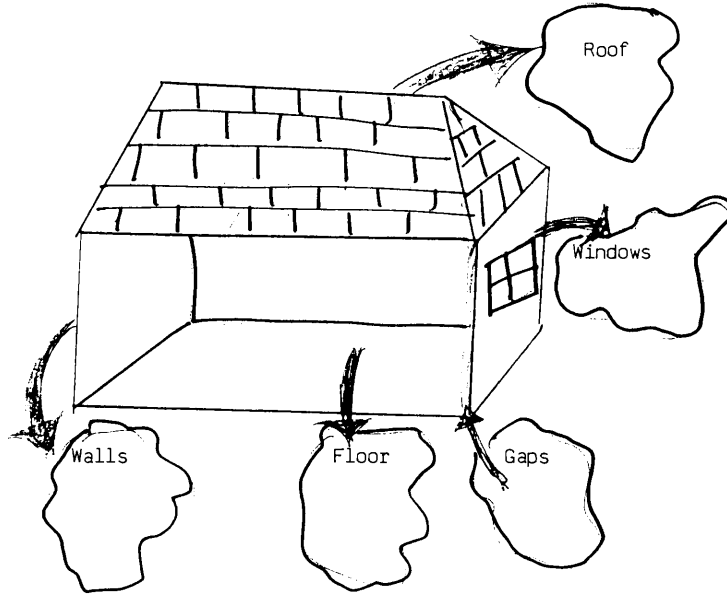

APPENDIX 9.

Household Data Form Masters
FOR THE SECONDARY SCHOOL.

Cedric 2.1

Community Energy
Display and Retrieval
of Information

British Gas 

Catalogue number 80

Teachers Notes.

Cedric 2.1 is designed to help pupils think about the way Energy is used in a house; and it what ways it could be made more energy efficient.

To enable the pupils to approach these questions, data is required, which the pupils can collect through the data collection sheets, then putting them into the program.

This will give them the D.H.L (Designed Heat Loss) of the house. Which can then be looked at to see how it can be improved.

Questimator which is the second part of the program - estimates the quantity and cost of the energy used for different purposes in the home.

The results are displayed both numerically and graphically.

To start the program running press "SHIFT BREAK".

This will give you the main menu so that you can proceed.

Cedric 2.1

Household Data Form

Information on this sheet is from:
Name
about the house at:
Address
CEDRIC 2.1 home number:

The data collection sheets are designed to follow the CEDRIC 2.1 program. The boxes on the left hand side indicate what will appear on the screen. On the right hand side are various boxes to record the data collected. The answers that go into the outlined boxes are that which are needed to make the program function, and correspond to the questions asked.

<p>The computer asks for the data like this</p> <div style="border: 1px solid black; padding: 5px;"> <p style="text-align: center;">CEDRIC 2.1 PROGRAM</p> <p style="text-align: center;">Home Number 1</p> <p>A question about the dwelling. Press a number next to your answer</p> <p>1.. Option 1. 2.. Option 2. 3.. Option 3. 4.. Option 4. 5.. Etc.. 6..</p> <p>0.. Finished answering questions.</p> </div>	<p>You tick or write your answers in a box like this</p> <div style="border: 1px solid black; padding: 5px;"> <p style="text-align: center;"><u>Type of information needed</u></p> <table border="1" style="width: 100%; border-collapse: collapse;"> <tr> <td style="width: 5%; text-align: center;">1</td> <td style="width: 85%;">Option 1</td> <td style="width: 10%;"></td> </tr> <tr> <td style="text-align: center;">2</td> <td>Option 2</td> <td></td> </tr> <tr> <td style="text-align: center;">3</td> <td>Option 3</td> <td></td> </tr> <tr> <td style="text-align: center;">4</td> <td>Option 4</td> <td></td> </tr> <tr> <td></td> <td>Etc.</td> <td></td> </tr> <tr> <td></td> <td> </td> <td></td> </tr> </table> </div> <p>Type of Information: needed NO = <input style="width: 40px; height: 20px;" type="text"/></p>	1	Option 1		2	Option 2		3	Option 3		4	Option 4			Etc.				
1	Option 1																		
2	Option 2																		
3	Option 3																		
4	Option 4																		
	Etc.																		

2: What is the total area of your external walls?

GEDRIC 2.1 - DHL

What is the total area of your external walls ?

Including windows and doors

Wall area
(in square metres)

TOTAL AREA OF EXTERNAL WALL =

3. What is the total volume of your house?

GEDRIC 2.1 - DHL

What is the total volume of your house ?

VOLUME
(in cubic metres)

TOTAL VOLUME OF YOUR HOUSE =

4: How are your windows glazed?

By filling in the information below, it will help you enter this section of data into the computer.

Notes:
 Enter areas in whole square metres only.
 Do-it-yourself secondary glazing -this should be described by the construction of the outer window.
 Type-this describes the frame adjacent to the glass. NB plastic frames-class as wood.
 Thermal break-some metal single and double glazed, framed windows have a plastic insert between the glass and frame.

Types and areas			S/G - single glazed D/G - double glazed T/B - thermal break							
Window number	Height (m) including frame	Width (m) including frame	Wooden frame S/G	Wooden frame D/G	Metal frame S/G	Metal frame D/G	Metal frame S/G-T/B	Metal frame		
1										
2										
3										
4										
5										
6										
7										
8										
9										
10										
11										
12										
13										
14										
15										
Total areas in m ²										

CEDRIC 2.1 - DHL

How much of your window area is single glazed with a wooden frame?

Just press RETURN if you have none.

Area
(in square metres)

Single glazed window with wooden frame.

CEDRIC 2.1 DHL.

How much of your window area is double glazed with wooden frame

Just press RETURN if you have none.

Area
in sq. mts.

Double glazed window with wooden frame

CEDRIC 2.1 DHL.

How much of your window area is single glazed with a metal frame?

Just press RETURN if you have none.

AREA
in square metres.

Single glazed with metal frame.

Area =

CEQRIC 2.1 D.H.L

How much of your window area is double glazed with metal frame?

Just Press RETURN if you have none.

AREA

in square metres.

Double glazed with metal frame

AREA =

CEQRIC 2.1 D.H.L

How much of your window area is double glazed with thermal break?

Just press RETURN if you have none.

AREA

(Square metres)

Single glazed with thermal break.

AREA =

CEQRIC 2.1 D.H.L

How much of your window area is double glazed with a thermal break?

Just Press RETURN if you have none.

AREA

Double glazed with thermal break.

AREA =

5: How is your ground floor mounted?

CEDRIC 2.1 - DHL

Home number 12
How is your ground floor mounted?

Press the number next to your answer

1 .. On joists.
2 .. Solid floor.
3 .. No ground floor.

1. Wooden joists
2. Solid floor (concrete)
3. No ground floor.

put number in box

6: What sort of roof do you have?

CEDRIC 2.1 - DHL		How much roof insulation is there in the roof?
Home number 11	What sort of roof do you have?	1 No insulation pre 1976
Press the number next to your answer	1 .. No insulation pre 1976.	2 No insulation post 1976
2 .. No insulation post 1976.	2 .. Insulated - 60mm.	3 Insulated to 60 mm
3 .. Insulated - 80mm.	3 .. Insulated - 80mm.	4 Insulated to 80 mm
4 .. Insulated - 100mm.	4 .. Insulated - 100mm.	5 Insulated to 100 mm
5 .. Insulated - 150mm.	5 .. Insulated - 150mm.	6 Insulated to 150 mm
6 .. Insulated - 200mm.	6 .. Insulated - 200mm.	7 Insulated to 200 mm
7 .. No roof.	7 .. No roof.	8 No roof
8 .. No roof.		

Tick the appropriate square, and put the number in the highlighted box

7: What sort of external walls do you have?

CEDRIC 2.1 - DHL		What type of external walls are there?
What sort of external walls do you have	1 Solid (no cavity)	<input type="checkbox"/>
Press the number next to your answer	2 Cavity (no insulation) built before 1976	<input type="checkbox"/>
1 .. Solid (no cavity).	3 Cavity (no insulation) built after 1976	<input type="checkbox"/>
2 .. Cavity-no insulation-pre 1976.	4 Cavity with insulation	<input type="checkbox"/>
3 .. Cavity-no insulation-post 1976.		
4 .. Cavity-insulated.		

Tick the appropriate box above and put the number in the shaded box

8: How much draught proofing do you have?

CEDRIC 2.1 - DHL	
Home number 12	Draughts
How much draught proofing do you have? Press the number next to your answer	How much draft proofing is there ?
1 ... No draught proofing.	1 None <input type="checkbox"/>
2 ... Some draught proofing.	2 Some <input type="checkbox"/>
3 ... Full draught proofing.	3 Full <input type="checkbox"/>

Tick the appropriate box above and put the number in the shaded box.

9: What's your Home number?

CEDRIC 2.1 - DHL	Fill in your home number. This will help you find your D.H.L. in the next section
What is your home No? Type 0 to finish	
Home Number <input type="text"/>	
Press RETURN or use DELETE to correct.	<input type="text"/>

10. This is what your screen will show.

CEDRIC 2.1 DHL		
On a cold day, if you keep your home comfortably warm, you will be loosing energy to the atmosphere thus		
Roof	Kw	%
walls	Kw	%
Windows	Kw	%
Floor	Kw	%
Gaps	Kw	%
DHL	Kw	%

Data Needed for Questimator

1. How many people normally live in your house?

CEDRIC 2.1 - QUESTIMATOR
How many people normally live in your home?
Type a number between 0 and 8.
Type 8 if more than 8.

How many people live in the dwelling?

2. Does your house have full central heating?

CEDRIC 2.1 QUESTIMATOR
Does your house have full central heating, and hot water?
Press Y or N

Does your house have full central heating?

IF YES

3: How is your central heating powered?

CEDRIC 2.1 QUESTIMATOR
How is your central heating powered?
Press a number next to your answer
1.. Gas.
2.. Electricity.
3.. OIL
4.. Solid fuel.

Put the appropriate number in the box

4: What is the D.H.L of your house?

CEOALC 2.1
What is the D.H.L of your home? <input type="text"/>
Type your answer then return.

D.H.L value =



Science Reasoning Tasks

TASK 1 SPATIAL RELATIONSHIPS MANUAL

Michael Shayer
Research Fellow, Chelsea College
University of London

Introduction

This Task* is one of a series developed by the team 'Concepts in Secondary Maths & Science' at Chelsea College, University of London in the period 1973/78 in order to investigate the relationship between the optimum Piagetian level at which a pupil can function and the understanding of Science which he or she can achieve.

This Task* tests coordination of spatial relationships and is based on Piaget and Inhelder's "The Child's Conception of Space", Routledge, London, 1956. Since the pupils draw their answers, it is particularly suitable for younger children and those with writing difficulties. It covers the range from preconceptual to late concrete (2B) operational thinking. The highest assessment possible is 2B+, which indicates fluency with concrete operations and the possibility of higher levels of thinking.

As with all the Science Reasoning Tasks the administration of this Task requires the active involvement of the teacher and this makes them aware of what the Task seeks to measure.

Equipment

Unlined paper, pencil and eraser for each child.
Empty jam jar on teacher's table clearly visible to all.
8 or so jam jars with lids or corks. From the centre of each lid hang a plumb-line, weighted with lead shot, plasticine etc., inside the jar. There should be enough jars placed around the class so that each child can see one clearly.

* For information on the use, development, statistics, etc. of this Task see the CSMS Science Reasoning Tasks *General Guide* (pub. NFER - NELSON)

Administration

1. Show the children the empty jam jar and ask them to "Draw this jam jar, but imagine there is some water in it and draw that too".

Ask them to draw a jam jar with water in it again, but this time:













- (a) tilted
 - (b) on its side, and
 - (c) upside down. If the children start to ask should the water be running out, tell them to draw what they think they will see when the jam jar, half-full of water, has been put in that position.
2. Ask them to draw a mountain with a house and trees on its sides. Make sure they understand that they are to draw them on the skyline, rather than on the front.

Ask them to put a chimney on the house they drew before with smoke rising from it. Tell them it was a still day, with no wind blowing.
 3. Ask them to draw the jam jar on their table that has a weight on a line hanging down inside it:
 - (a) With the jam jar upright and sitting on the table
 - (b) WITHOUT TOUCHING OR MOVING THE JAR AT ALL, ask them to draw it again as they imagine it would look if they tilted it
 - (c) TELL THEM THEY CAN NOW TOUCH THE JAR AND MOVE IT ABOUT. Draw again if they think their first drawing was not right, but the old drawing is not to be rubbed out.
 4. Ask them to imagine they are standing in the middle of a long straight road, lined with trees, going away from them into the distance. Ask them to draw it the way it would look.

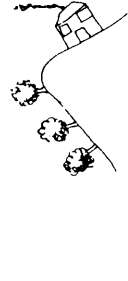
Go round the class while the children are doing the drawings. Check that they understand what they are expected to draw and see what "improvements" (if any) can be obtained by discussing any "mistakes", and note their reaction to the discussion. With a group of low ability, question 4 may be omitted if the Task has already gone on long enough. You may need to show them a simple cross-section drawing of a mountain and a jam jar on the board.

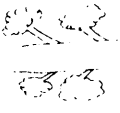
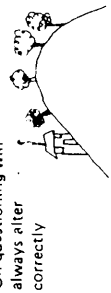
Notes on Assessment

- * Items 1 and 3 have a maximum scoring of 2B(4).
- ‡ For item 2, score 2B+(5) only if the general atmosphere of confidence distinguishes it clearly from the normal run of 2B performances.
- † For item 4, score 2B(4) for any signs of perspective, with vertical trees. Score 6 if the tree sizes are coordinated with the road perspective. Score 5 for intermediate cases.

Developmental Level (Piaget)	Score	1 Jam Jar and Water	2 Mountain, House and Trees	3 Plumb Line	4 Road with Trees
Preconceptual	0	Water's presence shown by scribble, no surface 	Trees and House not related to mountain 		
Intuitive or Pre-operational 1	1	Surface on water but parallel to base of container, even if tilted 	Trees and house at right angles to the mountain even where the surface is not horizontal 	Line stays nearly parallel to sides 	No attempt at perspective, trees at right angle to edge 
Early Concrete 2A (Intermediate)	2 (3)	Surface beginning to move towards lip as jar is tilted, but not consistently horizontal 	Some objects related to vertical as well as to mountain surface. Try asking about smoke from chimney (windless) 	On questioning they will always say line is vertical, but will still tend to draw it parallel to sides 	Trees start to be drawn upright but no perspective 
Late Concrete 2B	4	Finding result by trial and error. Maybe one mistake but will rectify this on questioning	Maybe an error or two. On questioning will always alter correctly 	As jam jar 	Trees drawn upright and they begin to bring far end of road bending together 
Late Concrete 2B or above 2B+	4,5,6	All right. Pupil appears to know before any trial	All right <i>wind blows!</i> 	All right Score 4	2B+ Full perspective Even inclination of edges into distance. Trees graded in size Score 6 

Emergence of an internalised Euclidean space of horizontals and verticals

* , † see notes opposite

Scoring

Enter the corresponding score for each item on the class assessment sheet. Take their sum, and give an overall assessment using these scoring rules.

Scoring Rules:	18 or above	– above 2B (2B+)
	14, 15, 16, 17	– 2B
	9 to 13	– 2A/2B
	6, 7, 8	– 2A
	5 or less	– 1

6.

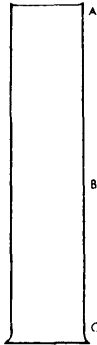

You see that water spills over when the block is lowered to A.

If it is lowered to B instead, will more

less

the same amount of water spill over ?

If it is lowered to C instead, will less

more

the same amount of water spill over ?

7.



What will the new volume-reading be?

.....

8.

If the plasticine is made into a ball, will the level be the same



higher

lower ?

9.

If the plasticine is made into a cylinder, will the level be the same



higher

lower ?

10.

If the metal block is lowered in, will more

less

the same amount of water spill over ?

Why?

.....
.....

- 11.
- a) Will this flat piece float
sink ?
 - b) Will this small flat piece float? YES
NO
 - c) Will this tiny piece float? YES
NO

- 12.
- a) This box, full of dry-cleaning fluid weighs 1500 grams.

Another box (twice as tall) filled with water weighs 2000 grams.
Would the box with the dry-cleaning fluid
float
sink in water?
How did you work out your answer?

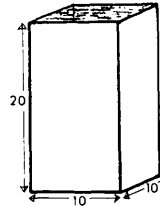
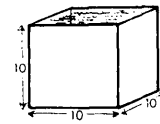

.....
.....

- b) When this box is emptied, and filled with alcohol it weighs 850 grams.
Will it float
sink in water?

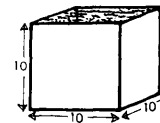

How did you work out your answer?
.....
.....

13. a)



How do you think Archimedes measured the old and the new crowns' volumes to compare them, using a measuring cylinder?

.....
.....

b) Archimedes then weighed the two crowns and found that the new, bigger crown weighed more than the old one. Nevertheless he said that the new crown had some lighter metal in it.

How do you think he worked it out?

.....
.....
.....

14.



Both blocks are made of the same brass.

A weighs 60 grams, and its volume is 15cm^3 .

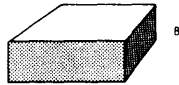

B weighs 160 grams.

What is its volume? cm^3 .

How did you work out your answer?

.....
.....

Homing in on HEAT FROM YOUR HOME



**Cartoon style HOUSEHOLD DATA FORM for use
with the CEDRIC 2.1 software (DHL and Guestimator)
Published by the British Gas Education Service**



Information on this sheet is from:

Name:

About the house at:

Address:

CEDRIC 2.1 home number:

Choose any number 1-40 (it need not be the number of the house used in the postal address). Each member of the class or group will need to choose a different number for their house. The computer will ask you for the number you give your house before it can work out the results of your survey.

What is the total area of your ground floor?

CEDRIC 2.1 DHL

What is the total area of your ground floor (if any)?

Just press RETURN if you have no ground floor

Floor area (in square metres)

floor?



How to find the total area of your ground floor

- (i) Measure the length of your house from the front door to the back, in metres

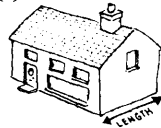

Length of house =

- (ii) Measure the width of your house from one side to the other, in metres

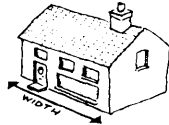

Width of house =

To find the area, multiply

Length of house \times width of house =

 m²

What is the total area of your roof?

CEDRIC 2.1 DHL

What is the total area of your roof (if any)?

Just press RETURN if you have no roof

Roof area (in square metres)

In most cases the answer will be the same as for the total area of the ground floor (see above)

 m²

THE ANSWERS IN THE SHADED BOXES GO INTO THE COMPUTER

What is the total area of your external walls?

CEDRIC 2.1 DHL

What is the total area of your external walls?

Including windows and doors

Wall area (in square metres)

To find this out you must:

- Count the number of outside walls
- Measure the length of each wall
- Measure the height of each wall
- Multiply the $L \times H$ to work out the area of each wall
- Add all the wall areas together

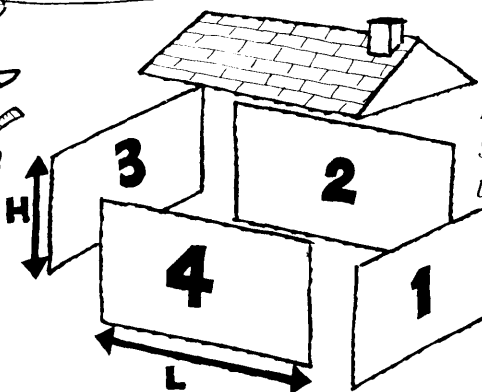

Here is an example, showing a house with only four walls

WALL 1 How long is wall 1? m
How high is wall 1? m

Multiply together = m²

WALL 2 How long is wall 2? m
How high is wall 2? m

Multiply together = m²

WALL 3 How long is wall 3? m
How high is wall 3? m

Multiply together = m²

WALL 4 How long is wall 4? m
How high is wall 4? m

Multiply together = m²

Do this for every outside wall that your house has

Then add them all together:
TOTAL AREA OF OUTSIDE WALLS = m²

THE ANSWER IN THE SHADED BOX GOES INTO THE COMPUTER

What is the total volume of your home?

CEDRIC 2.1 DHL

What is the total volume of your home?

Volume (in cubic metres)

To find out the volume of your home, you have to know:

How many floors has your home got?

How high is the 2nd floor?

How high is the 1st floor?

How high is the ground floor?

Add these numbers together. It will tell you how high your house is

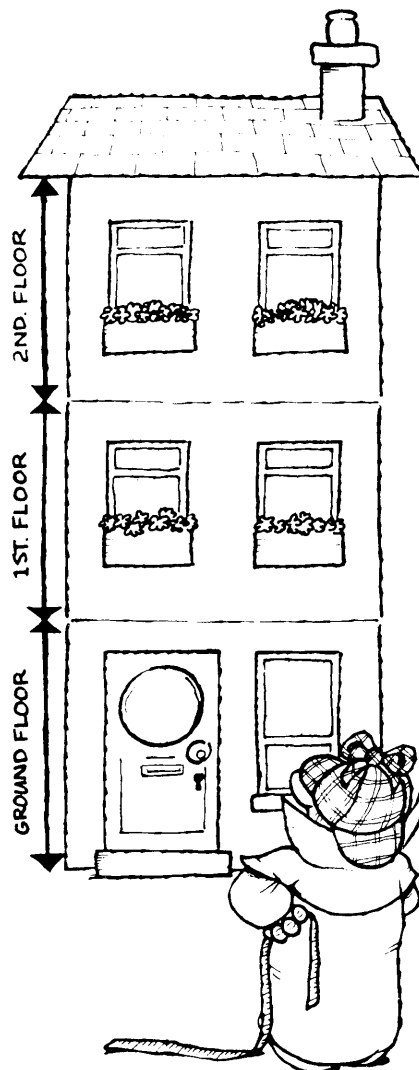

What is the volume of your home?

Volume = length × width × height. Also, volume = total area × total height
You already have these answers:

$$\text{VOLUME} = \boxed{\text{TOTAL AREA}} \times \boxed{\text{HEIGHT OF HOUSE}} = \boxed{\text{m}^3}$$

THE ANSWER IN THE SHADED BOX GOES INTO THE COMPUTER

How much of your window area is double glazed with a wooden frame?

CEDRIC 2.1 DHL
 How much of your window area is double glazed with a wooden frame?
 Just press RETURN if you have none
 Area (in square metres)

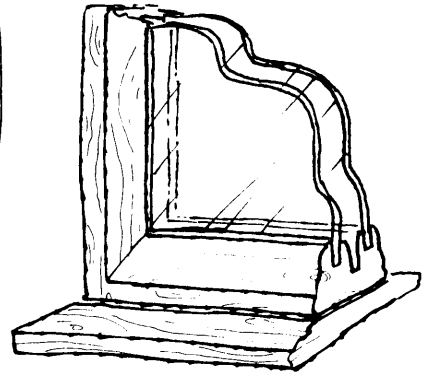

To find the area of a window

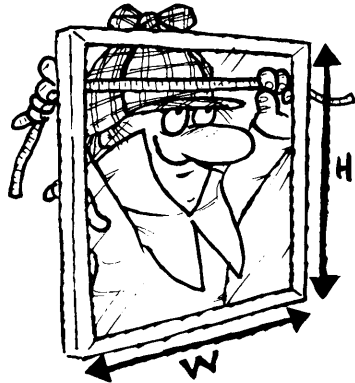

Measure the height of your window in metres

Measure the width of your window in metres

Area = height \times width
(square metres)

To find the total area of your windows

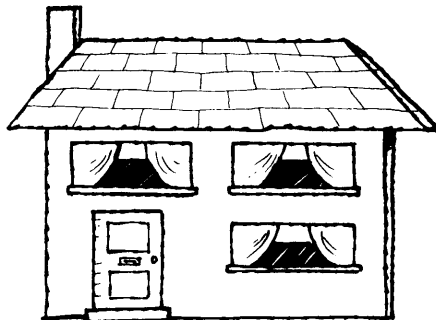

Count how many windows there are in your house =

Total area = How many windows \times area of one window

THE ANSWER IN THE SHADED BOX GOES INTO THE COMPUTER

How much of your window area is single glazed with a metal frame?

CEDRIC 2.1 DHL
 How much of your window area is single glazed with a metal frame?
 Just press RETURN if you have none
 Area (in square metres)

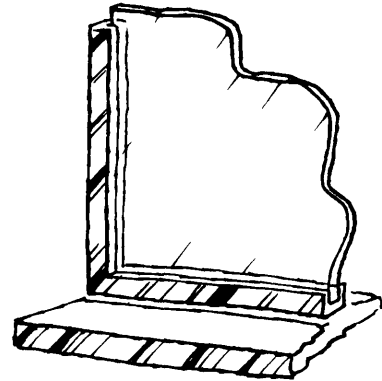

To find the area of a window

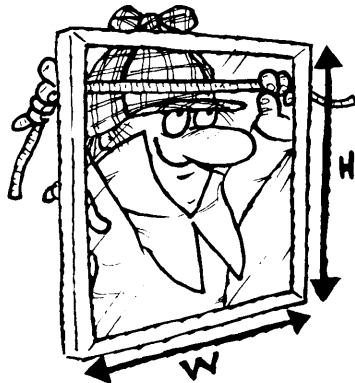

Measure the height of your window in metres

Measure the width of your window in metres

Area = height \times width
(square metres)

To find the total area of your windows

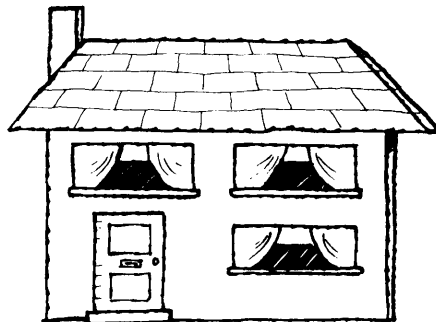

Count how many windows there are in your house =

Total area = How many windows \times area of one window

THE ANSWER IN THE SHADED BOX GOES INTO THE COMPUTER

How much of your window area is double glazed with a metal frame?

CEDRIC 2.1 DHL
 How much of your window area is double glazed with a metal frame?
 Just press RETURN if you have none
 Area (in square metres)

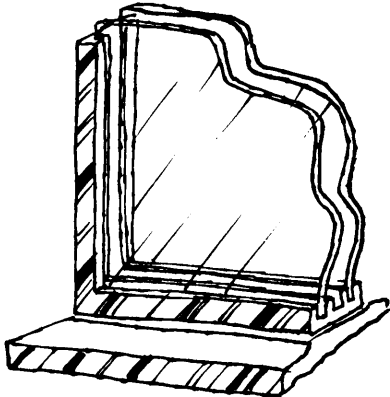

To find the area of a window

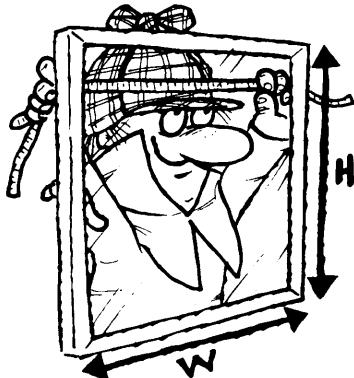

Measure the height of your window in metres

Measure the width of your window in metres

Area = height \times width
 (square metres)

To find the total area of your windows

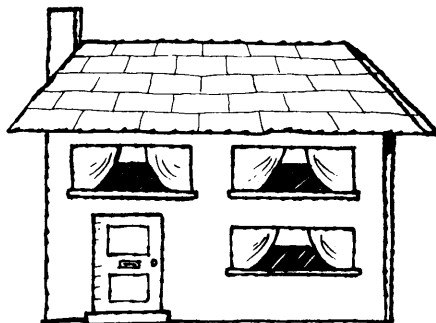

Count how many windows there are in your house =

Total area = How many windows \times area of one window

THE ANSWER IN THE SHADED BOX GOES INTO THE COMPUTER

How much of your window area is single glazed with a thermal break?

CEDRIC 2.1 DHL
 How much of your window area is single glazed with a thermal break?
 Just press RETURN if you have none
 Area (in square metres)

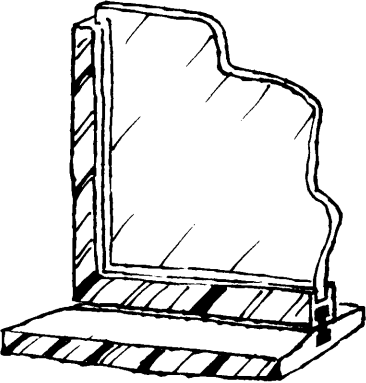

To find the area of a window

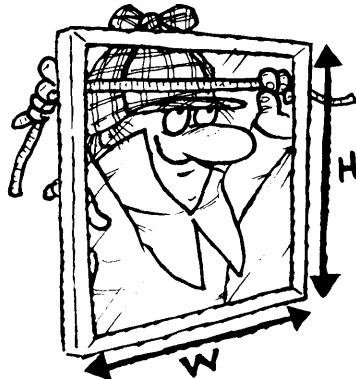

Measure the height of your window in metres

Measure the width of your window in metres

Area = height \times width
(square metres)

To find the total area of your windows

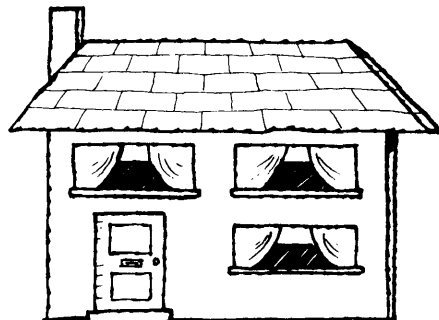

Count how many windows there are in your house =

Total area = How many windows \times area of one window

 m²

THE ANSWER IN THE SHADED BOX GOES INTO THE COMPUTER

How much of your window area is double glazed with a thermal break?

CEDRIC 2.1 DHL
 How much of your window area is double glazed with a thermal break?
 Just press RETURN if you have none
 Area (in square metres)

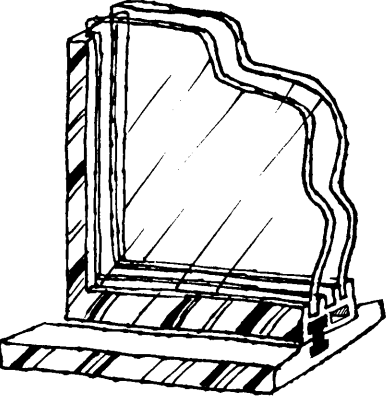

To find the area of a window

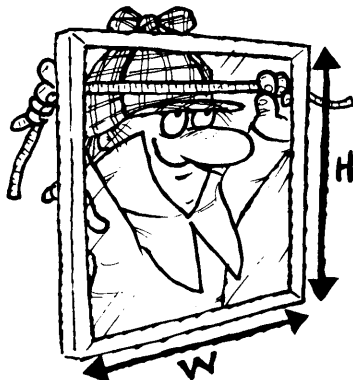

Measure the height of your window in metres

Measure the width of your window in metres

Area = height × width
(square metres)

To find the total area of your windows

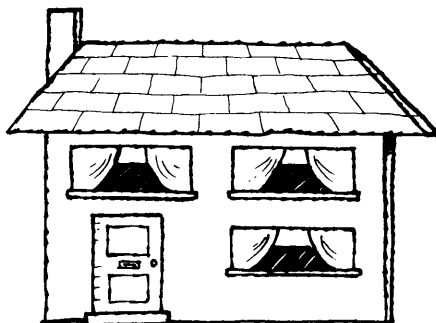

Count how many windows there are in your house =

Total area = How many windows × area of one window

THE ANSWER IN THE SHADED BOX GOES INTO THE COMPUTER

How is your ground floor mounted?

CEDRIC 2.1 DHL

How is your ground floor mounted?

Press the number next to your answer

1. On joists
2. Solid floor
3. No ground floor



1. Joists

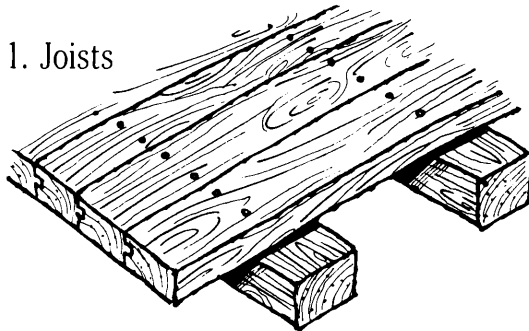

2. Solid floor



3. No ground floor

THE ANSWER IN THE SHADED BOX GOES INTO THE COMPUTER

What sort of roof do you have?

CEDRIC 2.1 DHL

What sort of roof do you have?
Press the number next to your answer

1. No insulation pre 1976
2. No insulation post 1976
3. Insulated – 60mm
4. Insulated – 80mm
5. Insulated – 100mm
6. Insulated – 150mm
7. Insulated – 200mm
8. No roof

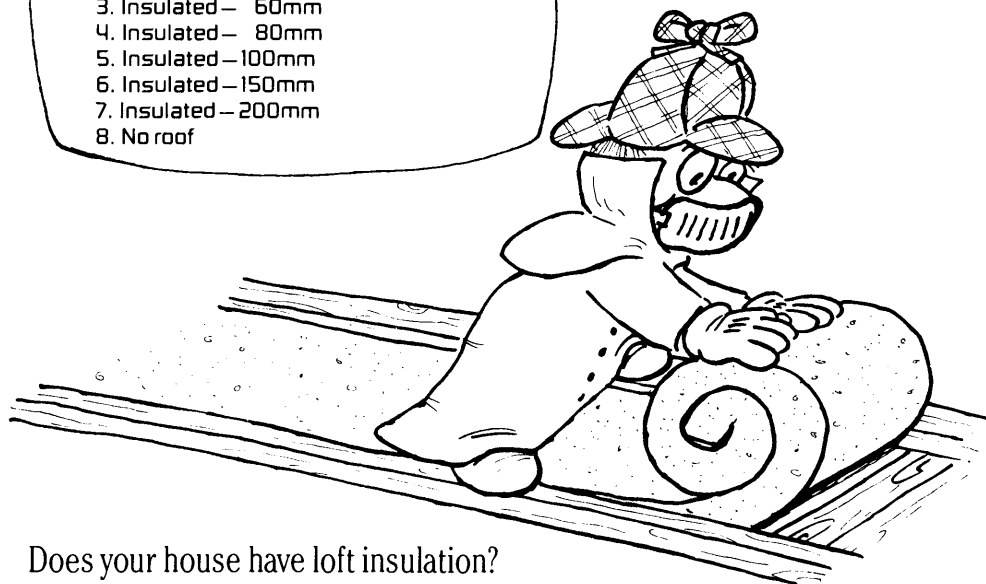

Does your house have loft insulation?

Tick one box

YES

NO

When was your loft insulated and how thick is the insulation?

TICK ONE SHADED BOX

1. No insulation pre 1976

5. Insulated – 100mm

2. No insulation post 1976

6. Insulated – 150mm

3. Insulated – 60mm

7. Insulated – 200mm

4. Insulated – 80mm

8. No roof

THE ANSWER IN THE SHADED BOX GOES INTO THE COMPUTER

What sort of external walls do you have?

CEDRIC 2.1 OHL

What sort of external walls do you have?
 Press the number next to your answer

1. Solid (no cavity)
2. Cavity – no insulation pre 1976
3. Cavity – no insulation post 1976
4. Cavity insulated

This question is about how the outside walls of your house are built.

Tick one of the shaded boxes. The black boxes will help you answer the questions for the shaded box

Are they solid brick like this?

Are they cavity bricks like this?

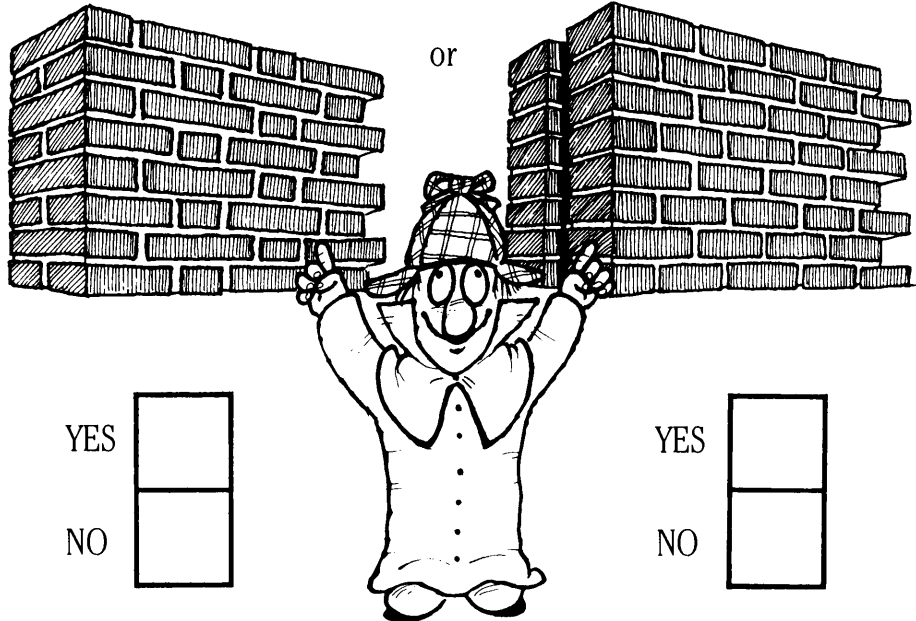

What sort of external walls do you have?

1. Solid (no cavity)	<input type="checkbox"/>
2. Cavity – no insulation pre 1976	<input type="checkbox"/>
3. Cavity insulated	<input type="checkbox"/>
4. Cavity – no insulation post 1976	<input type="checkbox"/>

CAVITY WALL WITHOUT FILLING

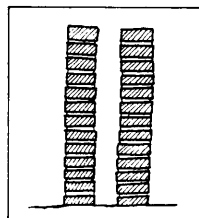

CAVITY WALL WITH INSULATION FILLING

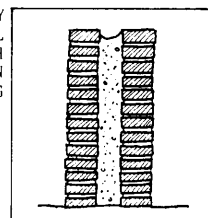

THE ANSWER IN THE SHADED BOX GOES INTO THE COMPUTER

How much draught proofing do you have?

CEDRIC 2.1 DHL

How much draught proofing do you have?
 Press the number next to your answer

1. No draught proofing
2. Some draught proofing
3. Full draught proofing



Here are some examples of draught proofing that will help you answer the questions

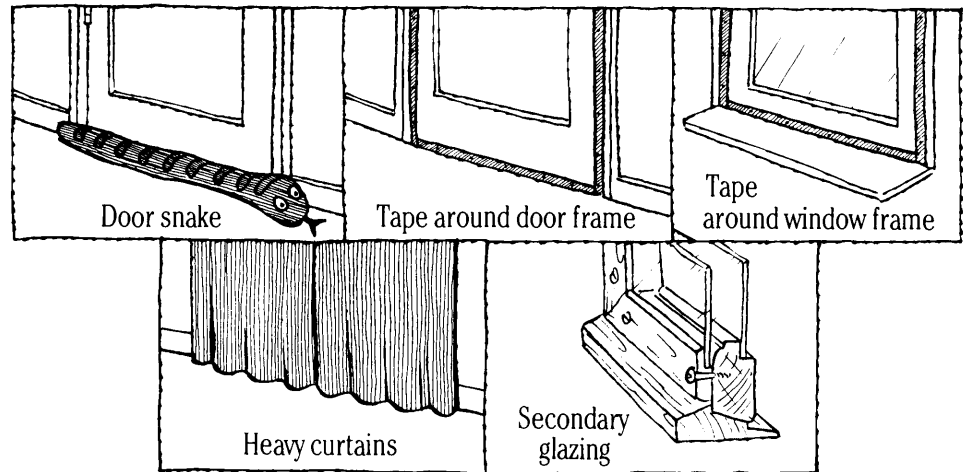

How much draught proofing do you have?

1. No draught proofing	<input type="checkbox"/>
2. Some draught proofing	<input type="checkbox"/>
3. Full draught proofing	<input type="checkbox"/>

THE ANSWER IN THE SHADED BOX GOES INTO THE COMPUTER

What do you want to do next?

CEDRIC 2.1 DHL

- What do you want to do next?
 Press the number next to your answer
1. Enter more answers
 2. Check and change your answers
 3. Save your answers
 4. Display your DHL
 5. Display your group's DHL
 6. Use another group
 0. Finish with program

Press number 4
 'Display your costs'
 (No 3 if using a
 Nimbus computer)

What is your home number?

CEDRIC 2.1 DHL

What is your Home Number?
 Type 0 to finish
 Home Number
 Press RETURN
 or Use DELETE to correct

FILL IN YOUR HOME NUMBER.
 THIS WILL HELP
 YOU TO FIND
 YOUR COSTS IN
 THE NEXT
 SECTION.

MY HOME NUMBER IS:



THE ANSWER IN THE SHADED BOX GOES INTO THE COMPUTER

The DHL chart for my home

CEDRIC 2.1 DHL

On a cold day, if you keep your home comfortably warm, you will be losing energy to the atmosphere thus:

Roof	Kw	%
Walls	Kw	%
Windows	Kw	%
Floor	Kw	%
Gaps	Kw	%
DHL	Kw	

Please RETURN to continue

This is what you see on the screen, but there will be lots of numbers beside each item. Fill in the numbers for your home from the screen in the table below

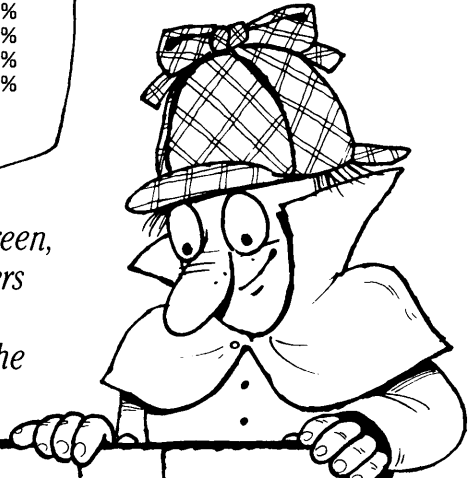

Roof	Kw	%
Walls	Kw	%
Windows	Kw	%
Floor	Kw	%
Gaps	Kw	%
DHL	Kw	

Energy loss from my home

Using the numbers from your DHL chart, fill in the gaps in the diagram with how much heat is lost through each part of the house

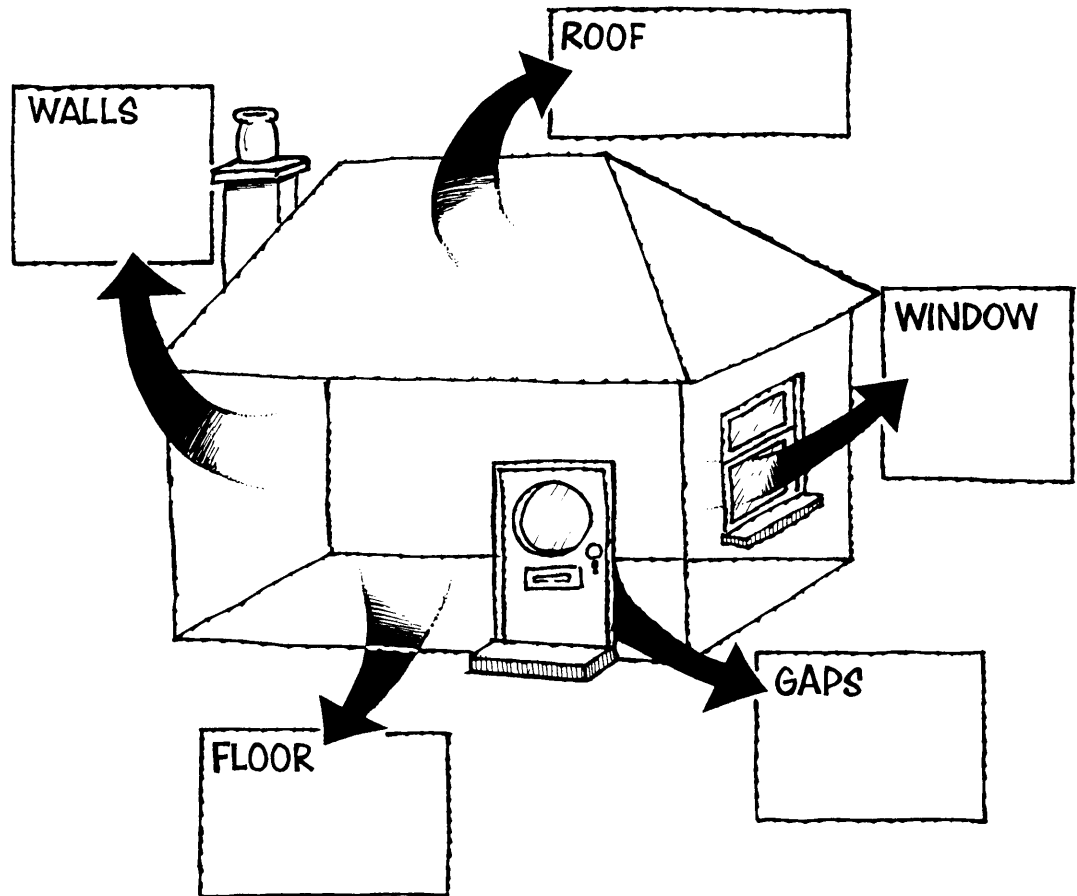

How much could this energy cost?

To find out go on the GUESTIMATOR PROGRAM. You will need to know your DHL figure

How many people normally live in your home?

CEDRIC 2.1 GUESTIMATOR

How many people normally live in your home?

Type a number between 0 and 8

Type 8 if more than 8

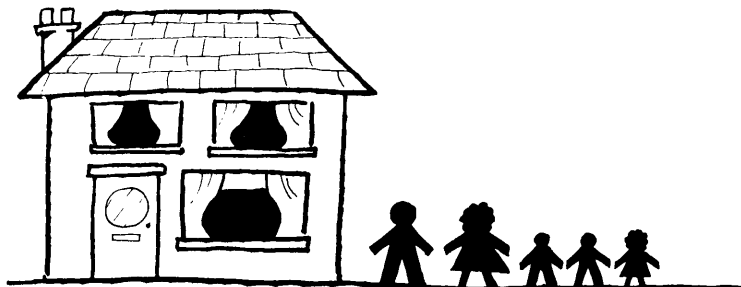
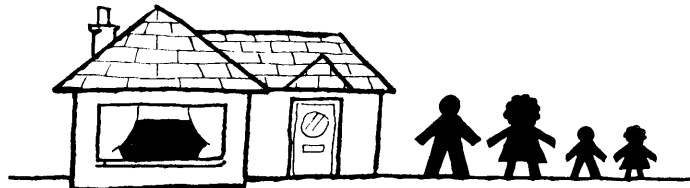
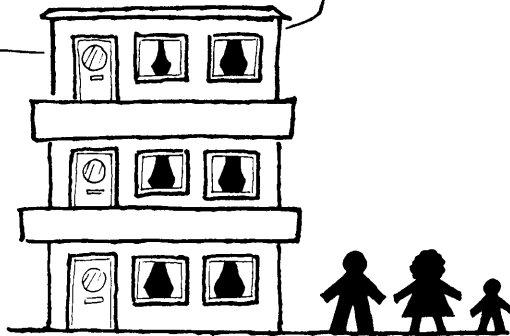

The number of people living in my home is

THE ANSWER IN THE SHADED BOX GOES INTO THE COMPUTER

Does your home have full central heating and hot water?

CEDRIC 2.1 GUESTIMATOR

Does your home have full central heating and hot water?

Press Y or N

My house has full central heating and hot water

YES

NO

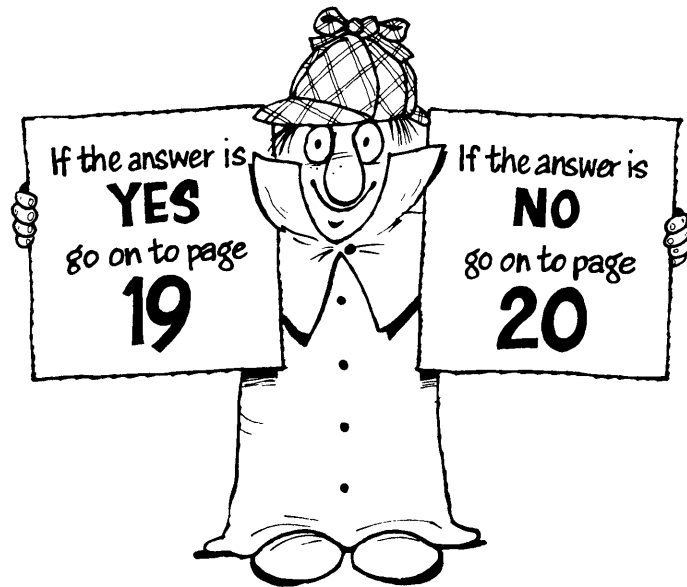

THE ANSWER IN THE SHADED BOX GOES INTO THE COMPUTER

If YES, how is your central heating powered?

CEDRIC 2.1 GUESTIMATOR

How is your central heating powered?

Press a number next to your answer

1. Gas
2. Electricity
3. Oil
4. Solid fuel



The central heating is powered by:

1. GAS
2. ELECTRICITY
3. OIL
4. SOLID FUEL

The central heating is powered by fuel number

DON'T FORGET TO PRESS RETURN

CEDRIC 2.1 GUESTIMATOR

What is the DHL of your home?

Type your answer then
RETURN

The DHL value

(look back to page 15)

NOW GO ON TO PAGE 23

If NO, which of these fuels heats your living room?

CEDRIC 2.1 GUESTIMATOR

Which of these fuels heats your living room?

Press a number next to your answer

1. Gas
2. Electricity
3. Bottled Gas
4. House Coal
5. Smokeless Fuel

My living room is heated by: 1. GAS

2. ELECTRICITY

3. BOTTLED GAS

4. HOUSE COAL

5. SMOKELESS FUEL

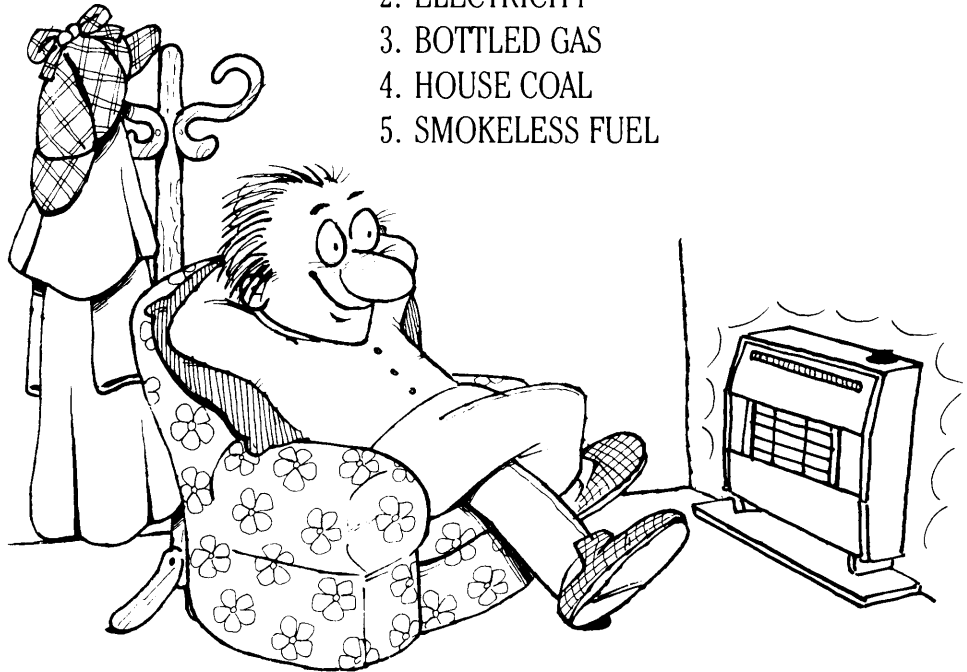

The type of fuel is number

THE ANSWER IN THE SHADED BOX GOES INTO THE COMPUTER

How many electric storage radiators do you have?

CEDRIC 2.1 GUESTIMATOR

How many electric storage radiators do you have?

Type number between 0 - 8

Type 8 if more than 8

Press RETURN

Number of electric storage radiators

How many gas wall heaters do you have?

CEDRIC 2.1 GUESTIMATOR

How many gas wall heaters do you have?

Type number between 0 - 8

Type 8 if more than 8

Press RETURN

Number of gas wall heaters

THE ANSWER IN THE SHADED BOX GOES INTO THE COMPUTER

How is your main hot water supply heated?

CEDRIC 2.1 GUESTIMATOR

How is your main hot water supply heated?

Press the number next to your answer

1. Gas
2. Electricity

The main hot water supply is heated by 1. GAS
2. ELECTRICITY



Main hot water is supplied by fuel number

THE ANSWER IN THE SHADED BOX GOES INTO THE COMPUTER

How is your cooker powered?

CEDRIC 2.1 GUESTIMATOR

How is your cooker powered?

Press the number next to your answer

1. Gas
2. Electricity
3. Bottled Gas

The cooker is powered by:

1. GAS
2. ELECTRICITY
3. BOTTLED GAS

The cooker is powered by fuel number

(Remember: solid fuel counts as electricity)



THE ANSWER IN THE SHADED BOX GOES INTO THE COMPUTER

Does your home have ...?

CEDRIC 2.1 GUESTIMATOR

Does your home have a fridge?

Press Y or N

1

CEDRIC 2.1 GUESTIMATOR

Does your home have a fridge/ freezer?

Press Y or N

2

CEDRIC 2.1 GUESTIMATOR

Does your home have a freezer?

Press Y or N

3

CEDRIC 2.1 GUESTIMATOR

Does your home have a washing machine?

Press Y or N

4

CEDRIC 2.1 GUESTIMATOR

Does your home have a dishwasher?

Press Y or N

5

CEDRIC 2.1 GUESTIMATOR

Does your home have a colour TV?

Press Y or N

6

Tick the Y or N box in each case

1 FRIDGE	Y	N	2 FRIDGE/FREEZER	Y	N
3 FREEZER	Y	N	4 WASHING MACHINE	Y	N
5 DISHWASHER	Y	N	6 COLOUR TV	Y	N

THE ANSWERS IN THE SHADED BOXES GO INTO THE COMPUTER

What do you want to do next?

CEDRIC 2.1 GUESTIMATOR

What do you want to do next?
Press the number next to your answer

1. Enter more answers
2. Check and change your answers
3. Save your answers
4. Display your costs
5. Display your group's costs
6. Use another group
0. Finish with program

Press number 4 'Display your costs' (No 3 if using a Nimbus computer)

What is your home number?

CEDRIC 2.1 GUESTIMATOR

What is your home number?
Type 0 to finish
Press RETURN or use
DELETE to correct



The home number entered was
(Use the same number as on page 14)

THE ANSWER IN THE SHADED BOX GOES INTO THE COMPUTER

From which British Gas region is your sample taken?

CEDRIC 2.1 GUESTIMATOR

Press the number next to your answer

1. Scotland
2. Northern
3. North Western
4. North Eastern
5. East Midlands
6. West Midlands
0. See other list of regions

SCREEN 1

WHAT IS THE NAME OF YOUR GAS REGION?

CEDRIC 2.1 GUESTIMATOR

Press the number next to your answer

1. Wales
2. Eastern
3. North Thames
4. South Eastern
5. Southern
6. South Western
0. See other list of regions

SCREEN 2

Look at both screens to find the name of your gas region

My local gas region is _____

It is region number

THE ANSWER IN THE SHADED BOX GOES INTO THE COMPUTER

Keep pressing RETURN/N until you see a table which shows

Use and cost by type of use

Home Number _____

Use	KWh	%	£	%
Heating				
Cooking				
Lighting				
Other				
Total				

Copy the information and make a bar chart

Compare your answers with others in your class to see what differences you can find

Think of a way of showing everybody's results



Appendix 12

YES RESPONSES FOR PRIMARY SCHOOL 1, BEFORE TEACHING

Things	Need	Get	Use Own	Use Up. f other	Store	Pass On	Lose	Have	Is
Person	32	8	22	27	32	12	31	30	9
Dog	32	5	26	29	30	6	29	31	11
Tree	32	9	15	24	23	8	26	28	9
Coal	2	26	7	11	20	27	25	25	29
Gas	5	28	11	18	23	26	24	26	29
Oil	1	25	12	15	21	28	25	24	31
Food	7	31	8	8	24	32	24	30	32
Glucose	5	32	12	10	28	31	23	27	27
Elec- tricity	8	29	19	18	30	31	28	30	32
Car	31	0	22	29	26	14	29	29	6
Wm Room	18	16	5	31	18	17	30	28	6
Light	30	10	18	28	12	15	27	27	19
Bicycle	32	4	5	26	2	8	14	12	4
Cooker	31	11	8	30	16	18	28	27	13
Foot- ball	30	2	2	28	3	3	23	18	3
Sun	6	32	22	9	25	32	15	28	28
Wind	1	23	22	6	19	26	14	25	24
Soil	14	8	8	19	21	15	22	22	12
Air	3	32	22	4	22	23	14	22	27
Water	4	29	20	6	20	28	11	24	26
Sea	2	23	16	7	17	21	10	25	21
Atoms	21	30	22	17	27	26	19	27	28

Do you want a printout of the next table?

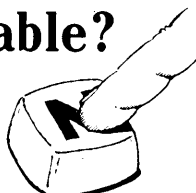

PRESS N.
(unless you have a printer already connected and switched on)

CEDRIC 2.1 GUESTIMATOR

Do you want a print out of the next table?

Press Y or N

Fuel amount and cost by type of fuel

This is what you see on the screen, but there are lots of numbers for each fuel. Fill in the numbers for your home in each of the boxes. Each one tells you about the approximate fuel costs for your home for one year

CEDRIC 2.1 GUESTIMATOR

Fuel amount and cost by type of fuel

Home number

Fuel	Quantity	£	Cost%
GAS (Therms)			
ELECTRICITY (Kwh)			
OIL (Litres)			
SOLID (Tonnes)			
LPG (Kg)			
TOTAL			

Home Number _____			
Fuel	Quantity	£	Cost %
GAS (Therms)			
ELECTRICITY (kWh)			
OIL (Litres)			
SOLID (Tonnes)			
LPG (kg)			
TOTAL			

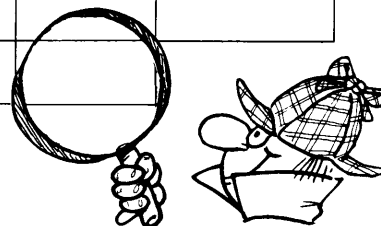

YES RESPONSES FOR PRIMARY SCHOOL 1, AFTER TEACHING

Object	Need	Get From	Use Up Its Own	Use Up. f. Other	Store	Pass On	Lose	Have	Is
Person	34	5	32	31	32	11	32	29	4
Dog	34	3	29	33	32	12	32	26	4
Tree	20	20	18	27	17	23	32	29	14
Coal	32	12	26	27	22	14	25	30	13
Gas	1	33	9	7	18	31	11	24	31
Oil	4	33	10	7	16	30	13	24	31
Food	2	33	9	7	18	29	10	23	33
Glucose	3	33	6	5	20	28	13	24	33
Elec- tricity	6	33	16	5	23	28	12	26	32
Car	4	33	10	4	11	25	15	23	28
Wm Room	29	3	12	28	4	8	20	13	5
Light	33	12	21	28	20	14	25	23	10
Bicycle	8	32	14	6	23	25	17	24	26
Cooker	33	1	30	30	29	8	27	29	6
Foot- ball	30	10	23	26	23	15	21	23	14
Sun	17	14	11	13	18	16	15	23	20
Wind	2	28	6	6	13	22	7	17	28
Soil	4	33	9	6	14	23	9	19	28
Air	6	26	8	7	12	21	8	19	26
Water	27	3	11	29	3	7	24	12	5
Sea	16	16	13	16	15	18	16	23	17
Atoms	10	25	21	25	16	24	20	21	28

YES RESPONSES FOR PRIMARY SCHOOL 2, BEFORE TEACHING

Total number of pupils 31

Object	Need	Get From	Use Up Own	Use Up f. Other	Store	Pass On	Lose	Have	Is
Person	31	14	28	22	30	12	31	31	8
Dog	18	21	30	25	30	18	31	31	3
Tree	24	22	8	29	27	19	31	26	16
Coal	28	22	25	22	19	17	30	27	17
Gas	5	30	22	14	25	24	29	30	28
Oil	8	30	20	13	25	23	28	29	28
Food	4	25	18	10	27	24	21	28	28
Glucose	17	31	4	18	26	30	24	30	26
Elec- tricity	16	29	16	14	30	29	12	30	29
Car	10	16	7	9	13	19	12	23	26
Wm Room	19	9	5	20	4	7	19	9	7
Light	29	20	23	25	21	24	30	23	12
Bicycle	15	29	6	16	30	26	14	20	21
Cooker	24	3	0	13	0	4	9	7	1
Foot- ball	29	14	21	20	24	20	23	27	16
Sun	22	15	9	13	22	18	15	18	18
Wind	9	27	5	9	10	24	11	21	21
Soil	8	21	5	16	15	18	9	26	20
Air	4	14	7	11	9	9	12	19	15
Water	16	9	6	23	5	8	18	13	10
Sea	19	15	15	16	19	15	16	19	21
Atoms	28	28	27	27	28	28	30	30	29

YES RESPONSES FOR PRIMARY SCHOOL 2, AFTER TEACHING

Total number of pupils 32

Objects	Need	Get From	Use Up Own	Use Up f. Other	Store	Pass On	Lose	Have	Is
Person	32	15	32	26	30	9	30	22	3
Dog	32	19	27	32	30	11	30	20	3
Tree	31	23	30	28	14	21	30	22	12
Coal	31	17	29	26	20	13	24	30	11
Gas	9	29	26	11	18	30	10	21	29
Oil	5	29	27	15	14	29	11	21	29
Food	7	28	27	14	16	27	9	20	31
Glucose	10	31	9	12	17	26	12	21	31
Elec- tricity	16	27	16	13	21	26	10	22	30
Car	9	21	17	10	9	22	12	19	25
Wm Room	22	6	6	25	3	6	18	10	3
Light	32	13	21	25	18	12	23	20	7
Bicycle	3	27	6	11	21	22	15	20	24
Cooker	24	3	20	22	26	6	25	22	3
Foot- ball	26	15	21	24	20	13	19	19	11
Sun	29	10	17	17	15	15	12	19	17
Wind	11	21	14	11	11	20	5	14	24
Soil	3	25	10	12	11	21	7	15	24
Air	6	10	11	11	10	19	6	15	23
Water	6	60	20	18	3	5	22	9	3
Sea	25	18	21	14	12	17	14	21	15
Atoms	22	23	27	22	14	22	16	19	23

YES RESPONSES FOR SECONDARY SCHOOL 1, BEFORE TEACHING

Total number of pupils 19

Objects	Need	Get From	Use Own	Use Up f. Other	Store	Pass On	Lose	Have	Is
Person	19	17	18	19	18	11	15	19	3
Dog	19	9	16	19	18	7	14	18	6
Car	18	6	17	19	17	11	17	18	3
Light	18	5	6	18	5	8	15	13	5
Bicycle	18	8	9	16	9	11	12	14	4
Foot- ball	18	13	8	17	10	12	14	17	8
Atoms	17	11	8	7	11	13	9	18	7
Tree	16	7	9	17	15	9	12	16	4
Cooker	16	4	10	18	6	5	17	15	3
Elec- tricity	12	17	9	12	13	16	10	18	16
Wm Room	6	8	4	15	11	9	18	14	4
Wind	4	19	7	5	11	16	7	17	16
Soil	4	6	5	8	9	9	10	9	7
Food	3	19	5	10	19	17	9	16	18
Sea	3	17	5	3	8	15	10	16	13
Coal	2	19	8	4	16	16	7	15	19
Glucose	2	19	1	6	17	15	10	17	16
Air	2	9	3	0	6	10	6	12	8
Water	2	17	6	3	10	15	8	15	14
Gas	1	19	8	5	16	16	8	16	19
Oil	1	19	7	5	16	16	7	14	19
Sun	1	19	12	2	14	18	5	17	19

YES RESPONSES FOR SECONDARY SCHOOL 1, AFTER TEACHING

Total number of pupils 19

Objects	Need	Get From	Use Own	Use Up f. Other	Store	Pass On	Lose	Have	Is
Person	19	7	19	19	15	10	17	19	4
Dog	19	8	15	19	15	6	16	19	4
Car	18	4	15	19	16	10	17	19	2
Light	18	10	2	19	3	5	18	12	4
Bicycle	17	8	3	14	11	10	10	13	3
Foot- ball	18	13	8	15	11	13	15	17	7
Atoms	17	13	10	10	12	16	11	19	9
Tree	14	4	7	17	10	7	14	13	2
Cooker	18	5	5	19	3	4	18	10	1
Elec- tricity	10	17	9	10	15	17	10	19	17
Wm Room	10	6	2	17	9	8	19	12	3
Wind	4	19	9	5	9	16	6	18	17
Soil	3	4	4	6	7	6	9	9	5
Food	3	19	3	10	19	18	8	15	19
Sea	3	17	5	3	10	15	10	14	11
Coal	2	19	10	3	18	18	7	18	19
Glucose	2	19	1	5	18	14	10	18	17
Air	1	10	3	0	6	10	4	11	9
Water	1	17	5	2	10	16	7	14	14
Gas	1	19	10	4	18	18	7	17	19
Oil	1	17	7	4	18	17	6	17	19
Sun	1	19	19	1	14	19	5	19	19

Appendix 13

CSMS TASKS RESULTS PRIMARY SCHOOL 2 CLASS 3

AGE	CHILD NO	TASK 1	LEVEL	TASK 2	LEVEL
10.0	1	19	+2B	7.0	+2B
9.6	2	14	2B	5.0	2A/2B
10.0	3	13	2A/2B	6.7	+2B
10.0	4	12	2A/2B	5.7	2B
10.2	5	11	2A/2B	6.3	2B
10.3	6	15	2B	5.7	2B
9.9	7	15	2B	8.8	2B/3A
10.0	8	14	2B	7.0	+2B
10.2	9	17	2B	6.3	2B
10.0	10	13	2A/2B	4.6	2A/2B
10.0	11	11	2A/2B	5.0	2A/2B
10.2	12	9	2A/2B	5.0	2A/2B
10.0	13	7	2A/2B	4.6	2A/2B
10.4	14	9	2A/2B	4.6	2A/2B
10.3	15	14	2B	7.5	+2B
10.0	16	8	2A/2B	7.5	+2B
10.0	17	13	2A/2B	5.7	2B
10.0	18	12	2A/2B	5.7	2B
10.3	19	14	2B	5.0	2A/2B
10.3	20	12	2A/2B	4.6	2A/2B
10.1	21	14	2B	6.7	+2B
10.3	22	11	2A/2B	5.7	2B
10.0	23	18	+2B	7.0	+2B
10.0	24	12	2A/2B	8.8	3A
10.5	25	14	2B	6.0	2B
10.1	26	15	2B	6.3	2B

CSMS TASKS RESULTS PRIMARY SCHOOL 2 CLASS 1

AGE	CHILD NO	TASK 1	LEVEL	TASK 2	LEVEL
11.3	1	19	+2B	6.0	2B
11.9	2	13	2A/2B	6.3	2B
11.7	3	15	2B	7.5	+2B
11.2	4	14	2B	6.0	2B
11.9	5	16	2B	6.3	2B
11.6	6	18	+2B	6.0	2B
11.6	7	16	2B	6.3	2B
11.0	8	17	2B	7.0	+2B
11.7	9	17	2B	7.0	+2B
11.5	10	17	2B	6.3	2B
11.6	11	16	2B	6.7	+2B
11.6	12	18	+2B	8.0	3A
11.0	13	18	+2B	7.0	+2B
11.0	14	16	2B	7.0	+2B
11.2	15	18	+2B	6.7	+2B
11.0	16	17	2B	6.3	2B
11.1	17	13	2A/2B	5.7	2B
11.5	18	13	2A/2B	5.7	2B
11.2	19	15	2B	6.7	+2B
11.9	20	12	2A/2B	3.5	2A
11.0	21	14	2B	5.7	2B
11.3	22	13	2A/2B	6.0	2B
11.6	23	13	2A/2B	7.0	+2B
11.0	24	14	2B	6.3	2B
11.4	25	14	2B	6.0	2B
11.0	26	--	??	6.3	2B

CSMS TASKS RESULTS PRIMARY SCHOOL 1 CLASS 1

AGE	CHILD NO	TASK 1	LEVEL	TASK 2	LEVEL
11.2	1	19	+2B	6.9	+2B
11.4	2	18	+2B	6.7	+2B
11.4	3	16	2B	6.5	2B
11.7	4	9	2A/2B	4.6	2A/2B
11.3	5	19	+2B	7.7	3A
11.6	6	13	2A/2B	4.4	2A/2B
11.0	7	11	2A/2B	4.4	2A/2B
11.0	8	11	2A/2B	4.2	2A/2B
11.6	9	13	2A/2B	4.0	2A/2B
11.7	10	8	2A	3.5	2A
11.4	11	7	2A	3.2	2A
11.0	12	19	+2B	7.1	+2B
11.0	13	8	2A	3.5	2A
11.3	14	15	2B	5.2	2B
11.0	15	6	2A	3.0	2A
11.7	16	18	+2B	6.9	+2B
11.4	17	12	2A/2B	4.3	2A/2B
11.2	18	14	2B	6.1	2B
11.6	19	7	2A	3.0	2A
11.5	20	19	+2B	7.7	3A
11.9	21	15	2B	5.6	2B
11.6	22	7	2A	3.1	2A
11.6	23	14	2B	5.2	2B
11.4	24	13	2A/2B	5.0	2A/2B
11.0	25	16	2B	5.9	2B
11.0	26	17	+2B	6.6	+2B
11.4	27	13	2A/2B	4.1	2A/2B
11.4	28	11	2A/2B	4.6	2A/2B
11.0	29	12	2A/2B	5.6	2B
11.5	30	18	+2B	6.7	+2B
11.6	31	15	2B	6.3	2B
11.6	32	19	+2B	8.5	3A
11.5	33	15	2B	6.9	+2B
11.3	34	16	2B	6.7	2B
11.3	35	14	2B	4.7	2A/2B
11.0	36	13	2B	4.8	2A/2B
10.10	37	20	3A	7.5	3A

APPENDIX 14

Revised Scoring of Science Reasoning Tasks

Since Science Reasoning Tasks (also known as Piagetian Reasoning Tasks) were first published by NFER in 1978, development work on them has continued, and a number of changes have been made. Most significantly for users of the SRTs, the method of ascribing a level of cognitive development to an individual has been made simpler and more reliable. This has been achieved through a complete reanalysis using Rasch scaling, which makes the best use of all of the pupil data and item data in arriving at scales.

The practical outcomes of this process for task users are that:

- you should ignore the section on "scoring rules" in the teachers' manual (and the subpara "scoring" on p.12 of the General Guide);
- you can now make your assessment simply on the total number of items that a subject has answered correctly; and
- the level of development is expressed directly as a number on a scale. The scale is based on the following ascription of scores to the **beginning** of each of the levels and sublevels of thinking:

Early concrete	2A	3.0
Mid concrete	2A/2B	4.0
Mature concrete	2B	5.0
Concrete generalisation	2B+	6.0
Early formal	3A	7.0
Mid formal	3A/3B	8.0
Formal generalisation	3B	9.0

Note that what we used to call transition is now "concrete generalisation." The level 3A/3B was not used before, but it corresponds to Piaget's mature formal operations. 3B is called formal generalisation. The table below shows the level of thinking on this scale which is indicated by a given total number of items correct, for this task.

Notes below indicate how you may still ascribe 2A - 3B descriptions of levels of thinking in line with previous assessments you may have carried out with this task.

Task II: Volume and heaviness	Total no. of items correct	Scale Score
	1	2.7
	2	3.5
	3	4.1
	4	4.6
	5	5.0
	6	5.3
	7	5.7
	8	6.0
	9	6.3
	10	6.7
	11	7.0
	12	7.5
	13	8.0
	14	8.8

You may ascribe "2A" if scale level is ≥ 3.5 ; "2A/2B" if ≥ 4.6 ; "2B" if ≥ 5.7 ; "2B+" ≥ 6.7 ; "3A" if ≥ 8.0 .

Taxonomy 1: Different aspects of the development of the child's interaction with the world.

Function	1 pre-operational	2A early concrete	2B late concrete	3A early formal	3B late formal
1.1 Interest and investigation style	Things are believed to be exactly as they appear to immediate perception. Perception dictates decisions. Faced with a mature person's idea of evidence, will deny it, explain it anthropomorphically, or be silent. Does not perceive contradictions.	Will register what happens, but for interest to be maintained after the first obvious observations needs a narrative or simple associative model ¹ . Unaided investigation style does not go as far as producing concrete models. (see 1.4—2A and 2B)	Will include seriation ¹ and classification ² as tools of perception in finding out what happens, but needs to be provided with a concrete experimental which to structure experimental results (classes must be given, and examples of the application shown). Finds interest in making and checking cause-and-effect predictions.	Finds further interest in beginning to look for why, and following out consequences from a formal model. Confused by the request to investigate empirical relationships without an interpretative model. Can use a formal model, (see 1.4—3A) but requires it to be provided. Can generate concrete models with interest. Can see the point of making hypotheses, and can plan simple controlled experiments, but is likely to need help in deducing relationships from results and in organising the information so that irrelevant variables are excluded at each step.	Finds interest in generating and checking possible 'why' explanations. Will tolerate absence of an interpretative model while investigating empirical relationships. Takes it as obvious that in a system with several variables he must 'hold all other things equal' while varying one at a time, and can plan such investigations and interpret results. Will make quantitative checks involving proportionality relationships.
1.2 Reasons for events	Interprets phenomena egocentrically, in terms of his own self.	See 1.1, 1.3, and 1.4: 'Cause-and-effect only partly structured—'this goes with that'; so uses associative reasoning. Simple one-factor causes, such as 'force', etc.	Bipolar concepts such as 'alkali destroys acid'. Can use ordering relationships to partially quantify associative relationships: 'as this goes up, that goes down'; 'if you double this you must double that', i.e. 'the reason' involves describing the relationship or category, not providing a formal model. Cause-and-effect structured according to general concrete stage schemas as 'adding acid makes the pH lower'.	Looks for some causative necessity behind a relation established with concrete schemas. Allows for the possibility of a cause that is not in 1:1 correspondence with observations. Can consider the possibility of multiple causes for one effect, or multiple effects of one cause. Can suspend judgement and allow results of controlled experiments to constrain choice among various cause-and-effect explanations. Can handle formal models as explanatory provided their structure is simple (see 1.4).	Because aware of multiple causes and effects can think of reality in a multivariate way, so can make a general or abstract formulation of a relationship which covers all cases in an economical way. Can use deduction from the properties of a formal model—either from its mathematical or internal physical structure—to make explanatory predictions about reality.
1.3 Relationships	Cannot consistently arrange data in an ordered series.	Can order a series, but is unlikely to see that as an obvious way of summing up observations. Nominal scale relationships—'same distance—same weight' (See-Saw).	Can multiply seriations, and hence can find 1:1 correspondences between two sets of readings (e.g. weights and extensions of springs), and hence any linear relationship. Ready uses the notion of reversibility. Will use compensation argument to explain a conservation where only ONE variable is independent, e.g. of a piece of clay 'you've made it longer, but it's thinner so its the same'. See also 2.2.	Uses compensation relationships between TWO independent variables, e.g. weights and distances on both arms of a balance can be changed while preserving equilibrium; resistance is related to both area and length, in electricity. See also 2.2. Simple functional relationships beyond linear, and thus accepted version of the concrete modelling described in 1.4(2B), rather than formal modelling.	Can reflect upon reciprocal relationship between several variables. Thus can handle quantitative 'relations between relations' as in proportions, or semi-quantitative relationships as in chemical equilibria. This level of thinking is often needed for analysing experimental results so as to order them for lower-level computation, e.g. weight changes in reactions involving different elements and compounds, or density calculations where density is an inferred concept (density of gases, or Archimedes' problems). See 2.4—3B.

¹Nominal Scale: scale with two values only: 'Four legs good; two legs bad'.
²Association: co-incident in time or place serving as basis for prediction.

¹Seriation: putting objects or data into order according to a property such as length, mass (ordinal scales).
²Classification: putting things in groups according to common property.

Function		2A early concrete	2B late concrete	3A early formal	3B late formal
1.4	Use of Models	<p>Concrete modelling is the organisation of reality by seriation or classification or 1:1 correspondence. At this level simple comparisons only, and elementary causes—'his opposite/his'. Unstructured notions such as 'bureness'.</p>	<p>Modelling by seriation extends to any linear scale. For classification see 1.5—see 1.4 and 1.3. Model now has arbitrary definition of dense model (skelcton; gear-box, etc.).</p>	<p>Formal modelling is the indirect interpretation of reality by deductive comparison from a postulated system with its own rules. At this level student usually needs guidance in deducing from a system with several variables many qualitative relationships in simple (e.g. with 'caloric' model of heat transfer, or 'pressure' as F/A) deduction is likely to be qualitative only (exchange reactions with metals and oxides). Model is taken as true, not hypothesis, so this level does not allow critical comparison of alternative formal models.</p>	<p>Can actively search for an explanatory model, extend one that is given, and compare alternative models for how they account for the same data. Since proportional thinking is readily available (relating two independent variables to each other) can formulate quantitative deductions from the model, and reflect on the relations between the variables.</p>
1.5	Type of Categorisation	<p>Thought is associational, and association of one aspect (e.g. height) not linked to another aspect (e.g. breadth) on a temporary basis. Thus has difficulty classifying objects into even two groups as successive judgements on one object are contradictory.</p>	<p>Elementary classification. Sets of objects are classified according to one major criterion at a time, e.g. colour, size, shape, etc. Children can also multiply classifications, i.e. 'big blue squares' and 'small squares'. 'Red big squares' and 'small squares'.</p>	<p>Generalization. Now the classifying operation is used to impose meaning on a wide range of phenomena. A general formula like $V=Ah/b$ will be used as an instruction for computing volume. Asked to choose the next term in the series 'Etna—volcano—...', would pick 'mountain' as the best classifier.</p>	<p>Abstraction. By contrast, would prefer 'geological notion' to 'mountain' as next step in categorisation. Because of the abstract nature of reality it is sometimes more powerful to search among the many properties for the essence of the underlying association. Mountain is a higher class, but geological notion abstracts so that connections with non-mountains can be explored. In $V=Ah/b$, the way in which A and b vary in relation to one another for constant V and V'.</p>
1.6	Depth of Interpretation (for descriptive passages)	<p>Does not look for contradictions in interpreting a descriptive account. Tends to pick on one feature only.</p>	<p>Imposes a consistent interpretation, but builds it around one feature of the account. Nominal scale interpretation.</p>	<p>Extended describer level. Still stays largely within the descriptive account, but considers more than one aspect at once (trees removed; rain on soil, soil washed away).</p>	<p>Explainer thinking. Not only are all the relevant features of the description accounted for, but hypotheses are tested against the data and, when necessary, inferences made imaginatively using outside ideas and data. (Examine whether a formal model (1.4—2A and 3B) is provided as an interpretation.)</p>

Taxonomy 2: The development of different 'schemas' required for the understanding of the sciences.

Type of problem	2A early concrete	2B late concrete	3A early formal	3B late formal
2.1 Conservation	Accepts that the amount of substance does not change, but still believes that weight and volume do, except in the very simplest situations, e.g. accepts volume constant when liquid poured to different shaped vessel, but volume of water displaced does not equal volume of displacing body. Conserves number and length.	Conservation of weight even when the dimensions of the body are changed. Volume conserved if body can be seen, but not if it dissolves.	All conservations. Now understands how the volume of odd-shaped objects can be determined by displacement. Notion of pure substance, which is conserved even when mixed with other (pure) substances. Realises that the volume of liquid displaced by a body does not depend on its weight.	Can formulate and quantify relationships between different ratio concepts introduced under 3A. Descriptions e.g. 'mixing the shadows cast by different rings, the ratio between the ring sizes and the distances has to be the same'. Think- ing in terms of direct or inverse relations between ratio variables (e.g. moles/litre, or mass/atomic mass) known how to model the relationships mathematically. See 2.4-3B. In volumetric work can handle computation in terms of V_1/P_1 , therefore C_1/C_2 .
2.2 Proportionality	Can double or halve the quantity of two related sets, e.g. if 2 oranges cost 4p, one orange costs 2p.	Has not arrived at metric proportions. Can make inferences from data involving constant ratio, so long as ratio is a small whole number, e.g. if 2 sweets cost 5p, 6 will cost 15p. Thus can scale up by factors of two or three, and partition using simple whole numbers.	Can make inferences where a ratio of simple whole numbers is involved, e.g. if a 2 kg box costs 12p and a 3 kg box costs 15p, which is the best buy? Can handle, as functional relationships, ratio variables such as density as weight/volume; current/voltage; surface gas volume changes with temperature and pressure. $n_1 V_1 = n_2 V_2$ in chemical volumetric work.	Can compare any ratio in two independent variables related to each other at equilibrium. When there are 3 or more variables related to each other at equilibrium, can conceptualise the relationship of the third to the other two, and thus arrive at a general law for the system, and can discuss the reciprocal relation of the first two variables e.g. in the case of the inclined plane relates the truck weight and hanging weight variables by equating them to the ratio of the vertical rise and fall of each. Can prove as an explanation for a relation established at 3A level, e.g. $n_1/n_2 = p_2/p_1$, because pressure produced by each arm is the same—leading to view of the whole system.
2.3 Equilibria of systems	See 1.3-2A. Observations ordered in terms of one property.	Relationships between variables only conceptualised two at a time, with the relationship (linear or otherwise) (Simple variables like force not compound variables such as pressure.)	Where there are two independent variables related to each other at equilibrium, the relationship included the ratios are simple whole numbers e.g. $3/2$; $1/4$; $3/4$, etc. e.g. $W_1/W_2 = L_2/L_1$ in a balance, or $n_1/n_2 = p_2/p_1$ in hydraulic press, without grasping the internal law of the whole system.	Can compare any ratio in two independent variables' equilibria by treating them as a proportion. When there are 3 or more variables related to each other at equilibrium, can conceptualise the relationship of the third to the other two, and thus arrive at a general law for the system, and can discuss the reciprocal relation of the first two variables e.g. in the case of the inclined plane relates the truck weight and hanging weight variables by equating them to the ratio of the vertical rise and fall of each. Can prove as an explanation for a relation established at 3A level, e.g. $n_1/n_2 = p_2/p_1$, because pressure produced by each arm is the same—leading to view of the whole system.
2.4 Mathematical Operations	Number is now distinguished effectively from size, shape, appearance. Number as a series, but confined to the numbers which can be given a concrete realisation.	Can work with single operations (e.g. addition, subtraction, division and multiplication) but the system of numbers must have closure, i.e. the operation must be unambiguous and the result of the operation must be within the set, e.g. $5 + 4 \times x$ can be solved, but $7 - 7 - 3$ or $5 \div 4$ cannot.	Concrete generalisation. Can work with the relationship $V = W/M$ or $W/H_1 = W_2/H_2$ but only by treating each step as a definite operation on definite numbers. Begins to accept lack of closure, e.g. can solve $7 - 7 = 7 - 3$ by a series of operations to each side of the relation.	Can properly conceive of a variable, and begins to work with the explicit rules of a system so as to develop proof strategies. See 1.3-3B. Rather than needing a formula where several variables are involved, can analyse the set of relations required by the model so as to sequence correctly a series of simple computations e.g. with a 'hydrogen-oxygen' model relating the weight changes relating to weights of other compounds can be computed. Before a density calculation can be set up the relevant weight and volume changes must be found.

Type of problem	2A early concrete	2B late concrete	2A early formal	2B late formal
2.5 Control of variables	Can reject a proposed experimental test where a factor whose effect is intuitively obvious is un-controlled, at the level of 'that's not fair', but fails to separate variables and so eliminate one. 'Fairness' may also be applied in the sense of giving every factor an equal chance, e.g. 'Slower runner should be given shorter distance'.	Will usually vary more than one factor in each experiment, and often varies other factors to test the effect of a given one.	Sees the need to vary one factor at a time and can suggest experimental tests to control for factors explicitly named. May fail to control factors that are not perceptually obvious. Fails to develop a strategy based on a feeling of the system as a whole. May not see the point of having an experiment without a factor present to see if it is a variable.	Sets up suitable experiments to economically control factors and eliminate ones that are not effective, and can apply 'all other things equal' strategy to multivariable problems. More sophisticated biological experiments possible including interaction effects. Appreciates the impossibility of controlling natural variation, and so the need for proper sampling.
2.6 Exclusion of Variables	In analysis of a multivariate problem (e.g. pendulum, flexibility of rods of different materials, shape, etc.) has no strategy for excluding interfering variables. May attempt to order the effects of factors and may arrive at the direction of the effects if they are intuitively obvious, e.g. 'longer rods bend more'.	Will order the effects of a given factor, but fails to exclude the interference of the other factors because he is trying to impose bivariate thinking. Thus often arrives at correct effect of a factor by invalid arguments. Unlikely to arrive at correct effect where it is contrary to intuition or where the factor makes no difference.	Will correctly arrive at the effect of a factor from experiments in which he/she has controlled for the other factors, but will often fail to exclude the effect of other factors when asked to select, from a group of experiments, those required to show the effect of each factor. Thus when two factors have been changed, and an effect is noticed, is likely to attribute change to the combination of both.	Because of an implicit knowledge of the different effects which may be caused by combinations of the variables that are possible will select economically from a variety of experiments those required to show the effect or non effect of each in turn.
2.7 Probabilistic Thinking	No notions of probability.	Given 3 red objects and 3 yellow objects mixed up in a bag, realises that there is a 50/50 chance of drawing a red one.	Given other ratios of objects will count the numbers of the given type (n) and the number of all objects (N) and express the chance of selection as a fraction n/N .	
2.8 Correlational Reasoning	Makes measurements by comparing beginning and ending of object/journey with rule in simple whole numbers.	No systematic method of estimating the strength of a relationship except to look to see if the confirming cases are bigger in number than all the rest.	Realises that the opposite pairs are as important as each other. Thus takes the brown eyes/dark hair set together with the blue eyes/fair hair set, and compares it with the sum of the two disconfirming cases (brown/fair and blue/dark).	
2.9 Measurement Skills	Makes measurements by comparing beginning and ending of object/journey with rule in simple whole numbers.	Bar diagrams, histograms, idea of mean as the centre of a histogram, and variation as its breadth. Graphical relationships of first order equations. Interpretation of graphs where there is a 1:1 correspondence with the object modelled, e.g. height/time relationship for the growth of a plant.	Interpretation of higher order graphical relations in terms of rates (instantaneous slopes) and reciprocal relationships: conceptualisation of relationships between variables, e.g. in $V = I R$, if I rises (V constant), R and/or R must drop proportionally.	Interpretation of higher order graphical relations in terms of rates (instantaneous slopes) and reciprocal relationships: conceptualisation of relationships between variables, e.g. in $V = I R$, if I rises (V constant), R and/or R must drop proportionally.

Objectives in the sciences

Physics.

Topic	2A early concrete	2B late concrete	3A early formal	3B late formal
P.1 Floating and Sinking Density	At this level Mass, Weight, Volume, and Density are still 'collapsed' in a global notion of 'heaviness'; knows that wood will float, iron will sink, but without a general explanation available, he can only learn a series of individual facts about materials.	Specific theories of floating will be tested, and weight differentiated from mass as a variable. Volume will only partly be conceptualised, and so the weight/volume relationship will not yet be used as an explanatory tool. Different 'heaviness' of materials will be differentiated from 'bigness'. 'A small or a large piece of plasticine will both sink, because the stuff is the same, with the same heaviness.'	Volume conceptualised and displacement seen to be a function of volume, not weight. Weight/volume relationship will be utilised to generate hypotheses in the float-ing thinking problem. Complete solution including density of liquid unlikely to be discovered, but rules about relative density can be learned. 'You can find out if two things are the same substance by seeing if their weight/ volume ratio is the same.'	Can handle relationship between, say, density, mass, and spacing of particles. Could formulate a theory of floating relating density of solid to density of liquid, or is likely to find that the clue to the floating and sinking problem is the weight of displaced liquid.
P.2 Force and Pressure	Pressure = Force. 'Stiletto-heel' effect, i.e. The effect of a force is greater if it acts through a thinner surface. 'Force' is a concept which is ordered—'his bigger than her'	Force in liquids is greater at greater depth. Vacuum is treated as a negative force. Air exerts a global force. Force can be partitioned, e.g. where 1 kg weight is lowered on to different numbers of 1 cm ² blocks. The word 'pressure' may be used, but still given a working definition of 'force'.	Distinguishes force from pressure. Pressure is treated as force per unit area. The pressure in a gas or liquid is the same in all directions.	Can apply the pressure concept to the general understanding of conditions of equilibrium, e.g. in a hydraulic press, or water standing at the same height in two interconnecting tubes of different cross-sectional area.
P.3 Equilibrium of Physical Systems	Nominal equilibrium relationships, e.g. at ends of a see-saw in balance, both weights are the same. A smaller weight is more effective further from centre. To make a truck run down hill, put weight in it.	Produces an account of equilibrium in terms of bi-variate linear relationships. For a beam to balance, the heavier the weight the closer it must be to the centre. Likely to predict that halving the distance will compensate for doubling the weight. In the case of an inclined plane, can arrive at formulations like 'the greater the angle the more weight that is needed to stop a truck running down'.	If a system has two independent variables may find effect of each by a control of variables strategy. Can find equilibrium relationships where simple linear proportionality is involved, i.e. in a balance, given weights in 3:2 ratio will predict lengths from centre should be in $L_1/W_1 = L_2/W_2$. For a given angle, in the inclined plane problem, will discover the relative weights as a proportion.	Quickly arrives at a proportionality formulation which can be tested as a hypothesis. Can generalise equilibria such as those of a balance in terms of a <i>work principle</i> (dynamic compensation of more force by less distance). Thus in the more complex inclined plane problem can test and discard a 'more weight/less angle' hypothesis and arrive at the quantitative solution.
P.4 Momentum	Intuitive, global concept of the relative impetus of colliding bodies. Can make predictions with some success which imply that the speed and mass are 'allowed for', i.e. slower and heavier can balance faster and lighter.	Differentiation of velocity from mass as contributory components of momentum, i.e. has a <i>language</i> with which to talk about predictions.	Can use formula to calculate results of collisions when it is taught as an algorithm; i.e. as a procedure, together with elementary rules for the context of its application. Will realise that changes in momentum are caused by forces.	Reinterprets global concept of momentum in an analytical way. Deals with reciprocal relationship of mass and velocity, and can deal with Newton's first law as a conservation statement.
P.5 Velocity and Acceleration	Intuitive notion of speed, but speed and relative position not differentiated, thus likely to call that one faster which ends up ahead.	Speed as relating distances and time (feet per second; m.p.h.)—hence speeds compared by distance travelled in same time. Intuitive notion of acceleration.	Acceleration conceived as rate of change of velocity. Thus 'ticker-tape' experiments on inclined plane begin to make sense. Can use second-order equations involving constant acceleration as a taught algorithm. ($S = ut + \frac{1}{2}at^2$)	Acceleration as the limiting value of $\frac{\Delta v}{\Delta t}$

Topic	2A early concrete	2B late concrete	2A early formal	2B late formal
P.6 Newton's Laws	See P4, P5 and P2.	See P4, P5, and P2.	See P.4 for First Law. Where accelerations are constant can handle Second Law as a relationship between Force, Mass, and Acceleration. Unlikely to grasp the necessity for the Third Law, but can see the sense of it when confronted with experimental evidence.	See P.4 for First Law. Can analyse problems to see how to apply the first two Laws, and plan sequence of computations. Since he is likely to think in terms of proof strategies can eventually see (from many examples) the necessity for the Third Law, and will treat all three as a set of axioms which produces consistent results.
P.7 Electricity	Bulbs light when connected to batteries. A bright bulb has more energy than a dim bulb. Likely to internalise a 'one connection' model of electricity flow. No potential/current distribution.	Can use voltage as a global measure of electrical forces. Although readings on an ammeter are used, as a measure of electricity, concept of current tends to be collapsed under voltage, so effects of current are given a 'voltage' explanation.	Notion of resistance as V/I ratio. Can use a fluid model of current flow and predict it in circuits, e.g. where direction of some of the branches is reversed. In terms of a consistent two-connection model - \rightarrow & \leftarrow will realise that a light bulb must have a second connecting point for the filament.	Potential as an intensive property is distinguished from the extensive property of electricity, and hence potential as work required to transfer charge between two points. Potential drop in different parts of a circuit may be modelled (at least needs to be taught well).
P.8 Temperature and Heat	No distinction between heat and temperature. Temperature as a qualitative concept of hotness and coldness.	Temperature quite well conceptualised as linear 1:1 mapping of the number line on to 'degree of hotness'. Amount of heat only implicitly conceptualised - usually collapsed under temperature. Amount of heat depends on mass of hot substance.	Caloric model of heat/temperature relationship, and calculations involved. Kinetic theory picture accepted as providing explanation of particular phenomena, but not integrated with heat/temperature model.	Can use kinetic theory as productive and explanatory model. Therefore can begin to appreciate the First Law of thermodynamics, and can deal with thermal equilibria as dynamic and statistical.
P.9 Kinetic Theory		See: Tax 1.4. In no way is kinetic theory concrete modelling.	Used to explain only phenomena in simple correspondence with model. e.g. expansion due to greater vibration of particles, so particles expand or take up more space. Solution seen as intermingling of particles, so volume of solute is conserved.	Can appreciate its use as a deductive model) proceeding from simple postulates. Relative properties of gases, liquids, and solids explained. Relative diffusion rates of different gases, and of gases into a vacuum compared with into air. Ready to appreciate quantitative derivation of gas laws and to conceive of temperature as only the mean value of a wide range of kinetic energies.
P.10 Energy and Power		Work is expended energy. Energy has many sources. Power can be differentiated from work. All three concepts are intuitive and anthropomorphic.	Work as a First's Distancing product. Kinetic energy defined as $\frac{1}{2}mv^2$. Can begin to think about stopping distances of cars from different speeds. Electric energy as $V \times I \times t$ product. Power as work done in unit time. Heat energy as calories.	Equivalence of different energy forms having each other (e.g. heat can be a potential (intensive) source. Energy as a work potential (extensive) and intensive force. Can begin to appreciate the problem of Heat as a form of energy is only partly convertible to work.
P.11 Thermodynamics		Conservation of energy as a learnt concept. Mechanical equivalent of Heat as a learnt fact.	Capable of seeing $dE = W - q$ as a postulate which connects measured quantities to a formal model which, like Newton's Laws, appears to yield consistent predictions. Thus can eventually see that Heat, as a form of energy, needs a second postulate to connect it with other forms of energy.	Can use wave model to account qualitatively for diffraction/interference phenomena. Can see Lens Laws as a deductive system and can learn to compute within their rules. Transverse and longitudinal waves and velocity or (minimisation) of path. Wavelength/frequency relationship as a comparison algorithm. Light as part of electromagnetic spectrum.
P.12 Light		Can use a linear propagation (ray) model to 'explain' reflection of near rays from a flat mirror. 'The smaller the angle it goes in, the smaller the angle it goes out'. Shadows larger the nearer the object is to the light.	Can use the Lens Laws to deal with real images (linear propagation model) but as algorithm. Uncomfortable with wave model as phenomena of light too obliquely connected with properties of model. Wavelength/frequency relationship as a comparison algorithm. Light as part of electromagnetic spectrum.	Can use wave model to account qualitatively for diffraction/interference phenomena. Can see Lens Laws as a deductive system and can learn to compute within their rules. Transverse and longitudinal waves and velocity or (minimisation) of path. Wavelength/frequency relationship as a comparison algorithm. Light as part of electromagnetic spectrum.

1. Double glazing stops draught getting in and heat getting out. The glass is double glazed to ~~me~~ which makes it stronger. They also reduce noise from outside coming in and disturbing you.
2. Cavity wall insulation consists of two walls built ~~about~~ ^{sew inches} ~~2 feet~~ apart with the gap filled with foam. This keeps the energy in the home and stops the cold ~~from~~ from getting in.
3. You would generally find insulation in the ~~roof~~ roof. It is used to cover the pipes to stop them from freezing.
4. Energy is very special ~~+~~ and vital to human life. It keeps people warm, as well as powering calculators to nuclear missiles. Many animals are able to produce their own energy.
5. Conservation of energy is when it is stored somewhere or used in a sensible way.

Michael Bristow

Double glazing is really a set of windows (two) in a window about an inch apart. They help keep the energy in and ~~some~~ stops heat coming in.

Sturdy wall insulation is built with brick about 6 inches apart with special insulation foam which traps the energy and gradually pushes it back into the house and also stops cold getting into the house.

Insulation is very important if you have alot of heaters and things. You would usually find it in walls and maybe in the roof. Insulation is a special material which tries to stop heat getting out.

Energy is very special for us without it we could not live. There are many things we can produce energy from things like the sun and water. Heat is an important energy source for our homes.

Conservation of energy is trying to save energy so not to waste it.

2. ~~insulation~~ ~~insulation~~

I found out about double glazing by watching television adverts. Double glazing works by trapping air between two panels of glass.

Cavity ~~insulation~~ works in the same way as double glazing but there are two walls one wall is made of heat insulating brick and the outside is made of normal brick.

Insulation means trying to stop heat from escaping from the main living quarters. ~~in~~ the house. We would find insulation in lofts and walls.

Energy means to me power to drive turbines and wind mills and helping us to live in comfort.

~~Insulation~~ Conservation of Energy means to me in saving heat in a house by using insulation. It also means to me in conserving electricity in a battery. And conservation explosive lava in the center of the earth.

Helen
Calver

I'm not quite sure where I learnt it from but I think that Double Glazing keeps the house warm because it is two layers of glass and therefore keeps more in the house, because the heat has to get through two layers of glass before it escapes. I think I learnt this when we had our house double glazed.

I think cavity wall insulation is when you build a house you build two walls and put foamy stuff like the foam babies sleep on. I think it's the same principle of double glazing in that it has two walls for the heat to escape through and the foamy stuff helps to keep the heat in.

I think insulation means keeping the heat inside the house and not letting any get out. There are lots of different types of insulation i.e. double glazing loft insulation cavity wall insulation etc.

Energy is something like gas, electricity, coal etc. that makes things work. Food is a type of energy because it makes us work.

Conservation means preserving things. Conservationists are people who want not to use sprays to protect the ozone layer and people who don't want the Channel Tunnel because the Lesser Spotted Blackbird might become extinct.

Conservation of energy means not to waste energy and to use it well

Connie

We found out about double glazing from this leaflet that came through the door. Double glazing is a window with two ~~pieces~~ pieces of glass in it. It saves a lot of heat and helps with condensation.

Cavity wall insulation is I think a kind of ~~foam~~ ^{gap} which you ~~put~~ ^{put} is between ~~the~~ two walls. I think they put foam in it to save energy and to keep the cold from coming in to the house.

Insulation means ways of preventing energy and heat to disappear. You should find insulation in the loft of a house, surrounding the boiler, and in between the walls.

Energy means fuel for life. It also means the food which we eat which converts into glucose which gives us the strength to move.

Conservation means to save something, like preventing animals etc. from getting extinct.

Conservation of energy means the ways or how we can save energy so that we don't waste it.

Thalia

Double glazing is a secondary window which is either sealed or is just two windows. I learnt about double glazing from looking and reading about double glazing. It helps us from letting energy escape.

I ~~do~~ have heard of ~~it~~ cavity wall insulation, and I ~~think~~ ~~it~~ ~~is~~ ~~not~~ ~~clear~~ haven't a clue what it does!!!!

I think insulation means a second sort of wall which helps the cold air go outside and let warm enter the house so you will not lose energy and keep the house warm.

I'm not sure what ^{you} you'd find insulation.

I think I'd use energy to keep your body warm, which will have to keep your house warm.

Conservation means I don't know!!!!

Conservation energy also means I don't know!!!!

melanie

We found out about double glazing from
my grandpa ^{and the teacher} ~~to~~ ^{to} save more heat, we
got it because we have a big
house and we thought it would save
more energy

Early on insulation, I think saves
heat from going out of the walls, so
so ~~more~~ ^{much} anyway we need it because
if we ~~lose~~ ^{lose} all our heat, our bills
would be high and we wouldn't
~~even~~ get as much heat as we should
do.

I think insulation means sort of
stuff you put in your roof etc,
so all the heat will stay more
compact ~~to~~

Energy means the electricity we
get and some thing else but
I can't think of it.

Conservation means I don't know
The conservation of energy means...
I don't know either.

James
Brown

I learnt about double glazing from some TV programs and adverts. Double glazing is two layers of glass that will prevent air coming through the windows.

Cavity wall insulation has an extra set of bricks in the wall as well as the insulation glass fibre (sort of fluffy stuff I think). If there was a space the cavity insulation would fill it up.

Insulation is used to keep heat in the house and help us save money.

We have insulation in roofs and windows and in walls.

Energy is to ~~keep~~^{play} our ~~selves~~^{play} playing sports or using our brain to ~~right~~ this, or coal or gas once lighted it will make energy.

Conservation is to save things like pandas lions birds.

Conservation of energy is to save energy from escaping out of the walls in the house or out of the windows.

An Energy Efficient House

First Stage:

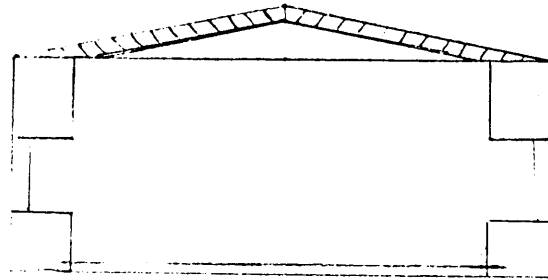

To get an energy efficient house is very good I have designed a house which I hope is energy efficient and here is the first stage.

Key:

- || = Double glazing window
- ▨ = insulation
- ▨ | = Cavity wall insulation
- = Insulated draught excluder

Roof Insulation

The first and one of the most important stages is roof insulation. I put insulation on the actual roof so to keep all the house warm.

The roof is one of the easiest ways of losing energy, so it is very important to insulate it well.

Second Stage:

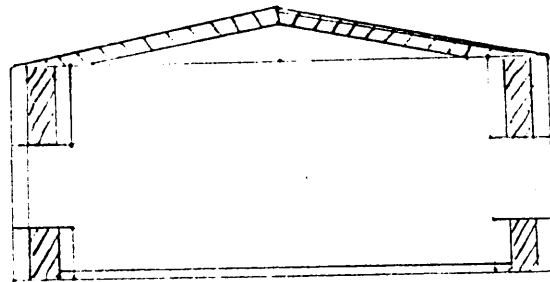

Cavity-Wall Insulation

Cavity-wall insulation is a very effective way of keeping energy in the house.

It has first a brick layer then insulation and finally another brick layer. I have used it in my design because I think it is one of the most effective ways of insulating any walls.

Third Stage:

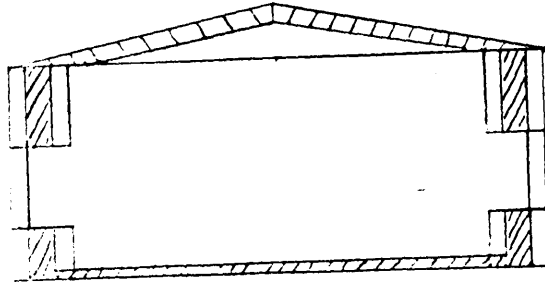

^{Floor Insulation}
Floor insulation is very important because energy can just sneak under the floorboards and get out.

I have used insulation here because it is better to keep warm than to keep turning the heat up in your home.

Fourth Stage:

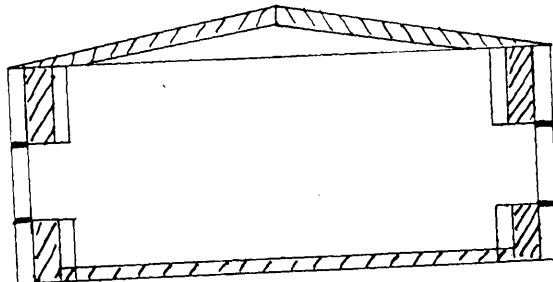

Double Glazed Windows

Double glazing is important especial in a weather exposed position.

Glass is very clever because it can let the heat in but won't let it out, the only problem is that it can also let draughts in.

The insulated draught excluders are special draught excluders so that I can put it on the windows.

Fifth Stage

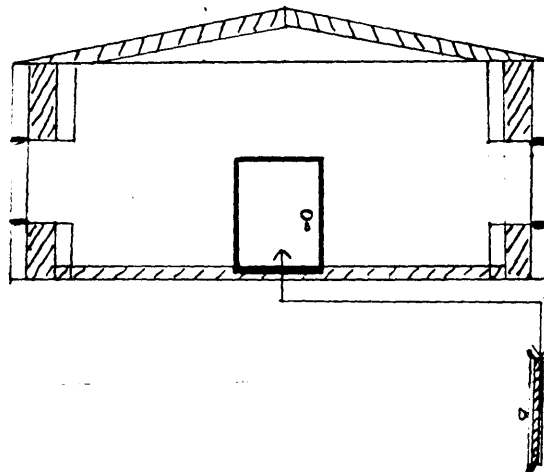

Insulated Front and Back door

Doors are another hazard especially when it comes to draughts.

Draught excluders are a must for any 'energy efficient house'.

I have used special insulated draught-excluders like on the windows to minimise draughts.

Dimensions of Childrens' Conceptions of Energy

*Gillian Nicholls
Jon Ogborn
Department of Science Education
Institute of Education
University of London*

Origin of the research

The work reported here forms part of some research into the potential use and value of energy related software in schools. In this paper we will concentrate on work concerned with the interpretation given to energy by pupils aged 11+ and 13+.

There is a considerable body of previous research on children's conceptions of energy. Watts (1983) proposes seven frameworks, some taken from work by Duit (1981) and Clement (1978). One of Watts' frameworks, 'human centred energy' is echoed by Solomon (1983a,b) in her discussion of something resembling vitalism in children's thinking. Bliss and Ogborn (1985) also found animacy to be a salient feature in children's judgments about energy. A list of accounts of children's ideas from the literature might read something like:

- energy as human or animate activity
- energy seen as a fuel
- energy related to movement or 'visible activity'
- energy as force
- energy as an (invisible) fluid

Solomon (1983a) stresses the difference between pupils' thinking in practical and theoretical contexts. Recent work by Mariani (Mariani and Ogborn 1990) suggests that energy is seen as both conserved and creative in nature, by contrast with living things which are creative but not conserved, space which is conserved but not creative, and ordinary objects which are neither creative nor conserved. We are concerned in this paper with similarly fundamental dimensions of children's thinking about energy.

The evaluation aspect of the present research required a simple instrument to help map pupils' ideas about energy. This led to the formulation of a questionnaire, which has now been through several stages of development and trials in both primary and secondary schools.

The questionnaire had to fulfil three basic criteria. We wanted it:

- 1 to be simple to use,
- 2 to be easily understood by a wide age range
- 3 to cover many aspects, in particular:
 - a of ways of thinking about energy,
 - b of objects that might relate to energy.

The questionnaire

In the initial development of the questionnaire 6 primary pupils and 12 secondary pupils were asked a series of questions requiring written responses, such as:

- What do you mean by energy?
- Where do you think energy comes from?
- How do we use energy?

The questions and their answers were then discussed in detail with pupils individually, to see which they found difficult, and to detect ambiguities or misunderstandings of the questions. Ideas collected from pupils at this stage were used later. Two points relevant to revising the form of the questionnaire became clear. One was that a test with written answers could not survey the necessary variety of kinds of entity and aspect of energy which we needed to cover. The second was that pupils seemed surer of their judgments than of their reasons, which they found hard to express and which we found hard to understand. Thus, as a device for getting a broad picture of the essentials of the structure of pupils' thinking, these questions were not a success.

We therefore opted for a questionnaire requiring only yes/no answers, about a wide variety of entities, asking for each about a range of features related to energy. This led to a questionnaire in the form of a grid, in which 9 aspects of energy were to be considered for each of 22 entities. The aspects chosen were all related to verbs; for example to what energy does, or how it is used. These verbs were taken from the interviews conducted with the pupils at the earlier trial stage and in some associated classroom work. The aspects chosen from amongst those most consistently talked about were as shown in Figure 1.

Figure 1 The aspects of energy chosen

The entities were chosen so as systematically to cover a wide range of interesting kinds of entity. The final selection is shown in Figure 2, grouped into four categories:

Figure 2 The objects used

The results reported here are from two schools:

(a) a class of 32 fourth year primary juniors aged between 10+ and 11+, of mixed ability. The school, of 200-300 pupils, has a varied, mainly urban catchment area. The school used a strong thematic approach especially in Science. Its teaching styles tend to be formal.

(b) a class of 19 third year secondary school girls, aged between 13+ and 14+. The school is a selective grammar school with a mainly urban catchment area. It has a strong science department.

In both schools, the questionnaire was given prior to starting a six week topic on Energy studies. It was completed by all the pupils at the same time. Questions were presented on a grid, to be filled with a tick or cross for all objects, on each aspect of energy, taking each aspect in turn. It was hoped that this would lead pupils to think carefully about each aspect.

Analysis: younger pupils

The analysis of the results set out to see how the entities grouped. The correlations between the entities, using the frequencies of responses on the nine aspects, were converted into 'distances' ($1 - \text{correlation}$) and subjected to multidimensional scaling (MDS), using the 'distances' only ordinally. This gives a map in two or more dimensions in which the Euclidian distances between points on the map reproduce as well as possible the order of the 'distances' taken from the correlations.

It will be convenient to present first the results from the primary class, and then later to make a comparison with those from the secondary pupils. In the case of these younger children, two dimensions explained 99% of the variance in the ordering of distances, with a low Kruskal stress of 0.024. Figure 3 shows the two dimensional scaling map of the objects.

Figure 3 Multi-dimensional scaling: younger children

The horizontal dimension in Figure 3 is the stronger, dividing the entities into two groups. However, the vertical dimension also divides them, and it is notable that this yields four groups which are remarkably close to those built into the selection of the entities, as shown in Figure 2. The only differences are that the car is found in the group of living things, that soil is found with the energy using devices and that atoms (intended to represent nuclear fuel) fall in the group of natural phenomena. It therefore appears that pupils do see differences in respect of energy between members of these four groups, seeing those within any group in much the same way.

Figure 4 shows how we arrive at an interpretation of these dimensions, and so at a characterisation of the differences between the four groups, as seen by these pupils. Figure 4 shows the percentages of *yes* answers for all the entities, for each aspect of energy. The entities have been reordered into the four groups

which emerge from the multi- dimensional scaling.

Figure 4 Percentage of 'yes' answers for entities: younger children

So far as the main, horizontal, dimension is concerned, the interpretation is rather clear. The entities in the groups *living things* and *energy using devices* fall on the right in Figure 3 and appear in Figure 4 as being frequently seen as needing energy and using up energy from other things, but not as things we can get energy from, which can pass on energy, or which are energy. Those in the groups *food and fuels* and *natural phenomena* fall on the opposite side of Figure 3 and appear in Figure 4 with a precisely complementary set of properties: they are often said to be things from which we get energy, which can pass on energy, and which indeed *are* energy, and are rarely said to need energy or to use up energy from other things.

Thus this dimension seems to be interpretable as *consumers* versus *sources* of energy. The sources are the foods and the fuels, such as oil, gas, coal, electricity, glucose, and also natural phenomena such as sun, wind, air, water, and the sea. Objects falling in the consumers category are the living things person, dog, tree, plus the car, together with the energy using devices: warm room, football, bicycle, light bulb, and possibly soil.

It is necessary to note that the aspect *it can have energy* does not distinguish the four groups at all, as can be seen in Figure 4. With the exception of the football and the bicycle, all entities are seen as possessing this feature.

The second dimension is less strong, and divides the entities in a rather more complex way. The aspect *it can use up its own energy* distinguishes the groups *living things* and *natural phenomena*, which fall along the bottom of Figure 3, from the other two which fall nearer the top. Thus this dimension seems to be about entities which do or do not use their own energy. It may be that the second dimension represents things which *act alone* as opposed to those which are *used to act*. However, the second dimension is also related to the aspects *losing* and *storing* energy. The energy using devices are rarely seen as storing energy, and the natural phenomena are rarely seen as losing energy. That is, *users* which are also *used to act* do not store energy, while *sources* which *act alone* do not lose energy.

This interpretation of the differences between the four groups of entities is summarised below and in Figure 5.

Figure 5 Interpretation of the dimensions

Living things (including car)

Seen as users/ consumers of energy, not as sources.
They use their own energy: they act alone.
They store energy, and they lose it.

Energy using devices

Seen as users/ consumers of energy, not as sources.
They do not use their own energy: they are used to act.
They lose energy, but they do not store it.

Foods/Fuels

Seen as sources of energy, not as users/ consumers.
They do not use their own energy: they are used to act.
They store energy, and they lose it.

Natural phenomena (including atoms)

Seen as sources of energy, not as users/ consumers.
They use their own energy: they act alone.
They store energy, but they do not lose it.

A factor analysis gave essentially the same results as the multidimensional scaling, as we have interpreted it. A first, and strongest, factor corresponded to the *source - user* distinction. Two further but weaker factors concerned respectively the *lose - store* differences and *use own energy*.

Analysis: the older pupils

Figure 6 shows the multidimensional scaling results for the older pupils, corresponding to Figure 3 for younger pupils.

Figure 6 Multi-dimensional scaling: older pupils

The scaling plot for the older pupils resembles that for the younger ones only in the main horizontal dimension (a test with Individual Differences Scaling using INDSCAL confirms this). The horizontal dimension still corresponds, as with the younger pupils, to the distinction *source - user*. The features which distinguish the objects on the horizontal axis are:

Users seen as:

Sources not seen as:

needing energy
using up energy from other things
losing energy

Sources seen as:

Users not seen as:

things from which we get energy
things which pass on energy
things which are energy

The second dimension seems not to exist. The three entities, *soil*, *warm room* and *atoms* which mainly contribute to this dimension appear to be placed on the scaling diagram as they are because they correlate very weakly with the majority of the other entities and with each other. As a result, the older children no longer distinguish the four groups of entities as the younger ones did.

Comparison of older and younger pupils

Figure 7 shows the percentages of 'yes' responses for each entity, for each feature. By comparing it with Figure 4, we can see how the thinking of the older children differs from that of the younger ones. The feature *uses up its own energy*, which for the younger children contributed to the second dimension, here picks out only the living things, which alone are very often seen in this way, and so now contributes something to the *source - user* dimension.

Figure 7 Percentage of 'yes' answers for entities: older children

The feature *it can store energy* shows a change: living things and fuels are now seen as storing energy, and energy using devices and natural phenomena are not so much seen in this way. The younger children picked out just energy using devices as not storing energy.

An inspection of more detailed differences has some interesting features. The younger children saw the mechanical objects football and bicycle as not having energy, but the older ones more often think that they do. This suggests that they now have some idea of mechanical energy. The older children less frequently think of the soil as a user of energy: they may know more about how plants grow. Also, the older children less often see atoms as a source: they now see them as needing energy and less often as something from which we get energy. Where the younger children saw the air as a source of energy, the older ones do so to a lesser extent. There is a corresponding sharper difference between fuels and natural phenomena, with the former a little more and the latter a little less often thought to be energy.

The view of electricity also differs. The younger pupils saw it as mainly a source,

but the older ones see it as both a source and to some extent a user (needs energy, uses up energy from other things). The devices cooker and light bulb, by contrast, are more definitely seen as users and not as sources by the older pupils.

Conclusions

We hope to have shown that it is possible to detect underlying structures in childrens' thinking about energy, by relatively simple means. The main structure, common to the younger and the older children, is a distinction between *sources* and *users* or *consumers* of energy.

Sources are not only things from which we get energy, but are also said to *be* energy. They include fuels, food and the sun, but they also include naturally active phenomena such as water, the sea, wind and even the air. For younger children, losing energy may be associated with losing activity, since it is these persistently active phenomena which are rarely seen as losing energy. For the older children, losing energy had become associated with being a user of energy.

Users or consumers of energy are the things which need energy and which use energy from other things. They include not only devices such as a cooker, light bulb and bicycle, but also living things. People or animals are no more seen as sources of energy than is a bicycle or a warm room.

The younger children saw the four groups living things, energy using devices, foods and fuels and natural phenomena as behaving in different ways with respect to energy. Both groups distinguished the groups in the same way as sources or users, but the younger ones appeared also to work with a distinction to do with things which act alone or independently, and things which are used to act. It may be that this way of thinking has to do with animacy, actual or projected, being associated with energy.

The detailed differences between the two groups suggest that the older pupils are less inclined to a simple equation of energy with activity. There were some signs supporting a view that they had begun to think of energy as something exchanged between objects, so that an object could be both a source or a user.

In conclusion, it seems that the strongest basic notion of energy is that of it as a source of action. It is interesting to reflect on what actually is, from a thermodynamic point of view, the source of action: on how it is that you and I can run, jump and sing. We feel that these things happen because we will them, but if we try to regard ourselves as purely physical systems the answer lies elsewhere, and not with our 'possessing energy'. We can do these things because we are physical systems far from equilibrium. But to say that makes us no more than like a bomb. However, unlike bombs, our actions do not seem to detract from the possibility of future action: we may get tired but we recover. This is because we are physical systems *in a steady state* far from equilibrium. How do we stay in a

steady state, when a system away from equilibrium must decay towards equilibrium? Only by ourselves feeding off other systems which are not in equilibrium. It is the natural, spontaneous, inevitable decay towards equilibrium of the world around us which gives us our power to act.

This account is new and not well known. It could not have been expressed at all before Schrödinger published his book *What is Life?* in 1949. But it seems that we cannot avoid confronting it if we are to say anything useful and true about people's ideas of energy.

References

- Clement, J. J. 1978, *Mapping a student's causal conceptions from a Physics problem-solving protocol* (Dept of Physics, University of Massachusetts, MA)
- Bliss, J. and Ogborn, J. 1985, Children's choices of uses of energy. *European Journal of Science Education*, Vol. 7, pp. 195-203
- Duit, R. 1981, Students' notions about the energy concept - before and after physics instruction, in Jung, W., Pfundt, H. and Rhoneck, C. V. *Problems concerning students' representations of Physics and Chemistry knowledge* Publisher
- Mariani, M-C. and Ogborn, J. 1990, Commonsense reasoning about conservation: the role of action. *International Journal of science Education* forthcoming
- Solomon, J. 1983a, Learning about energy: How pupils think in two domains. *European Journal of Science Education*, Vol. 5, pp. 49-59
- Solomon, J. 1983b, Messy, contradictory and obstinately persistent: a study of children's out-of-school ideas about energy. *School Science Review*, Vol. 65, No. 231, pp. 225-230
- Watts, D. M. 1983 Some alternative views of energy. *Physics Education*, Vol. 18, pp. 213-217

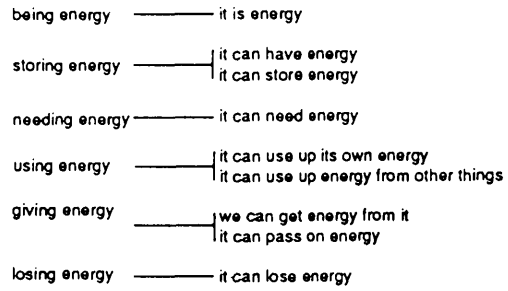

Figure 1 The aspects of energy chosen

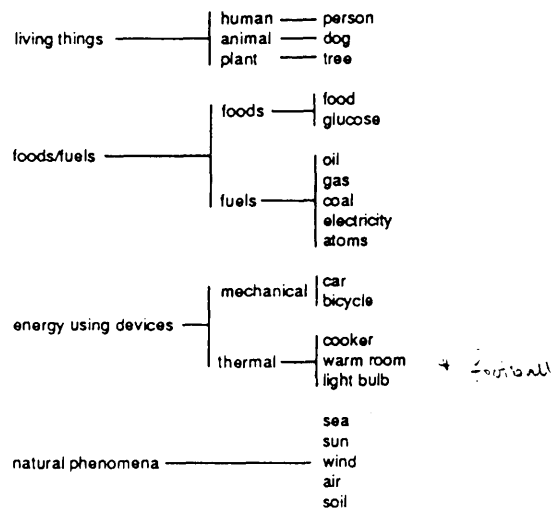

Figure 2 The objects used

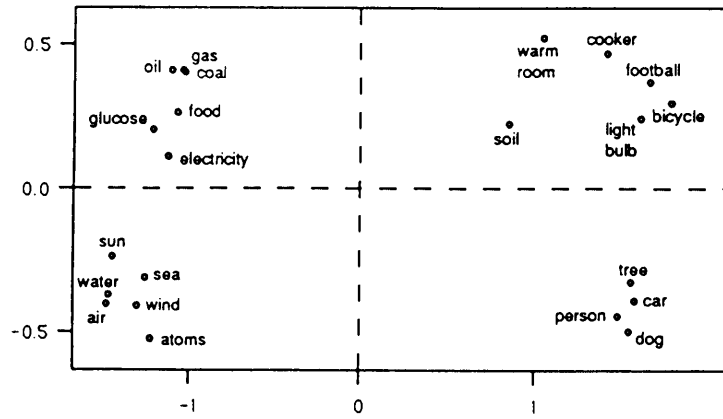

Figure 3 Multi-dimensional scaling: younger pupils

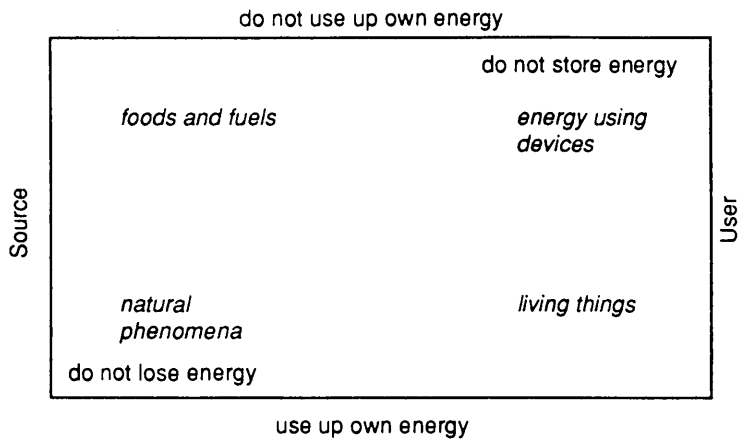

Figure 5 Interpretation of the two dimensions

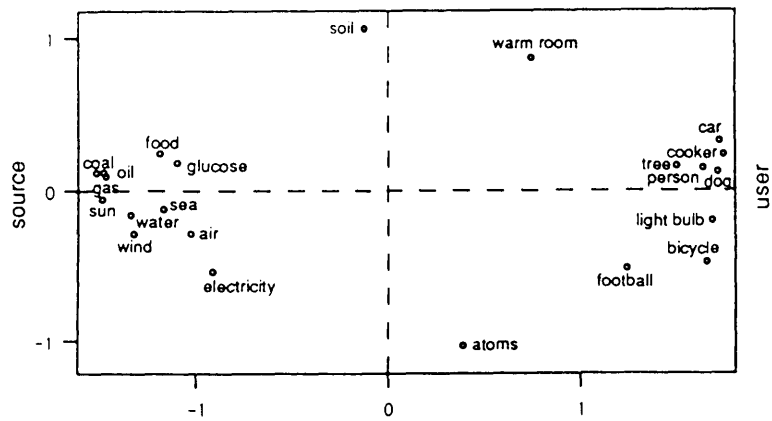

Figure 6 Multi-dimensional scaling: older pupils

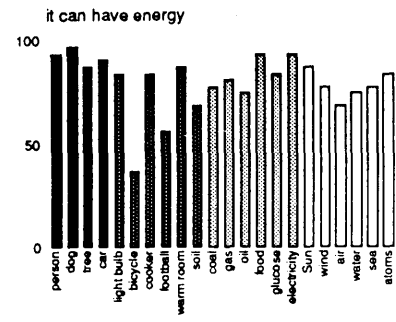
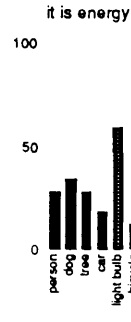
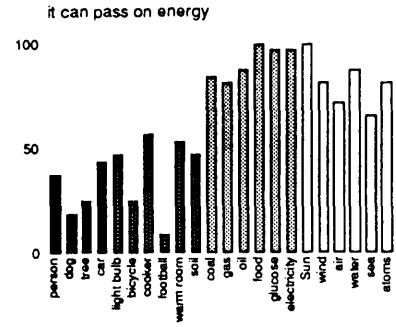
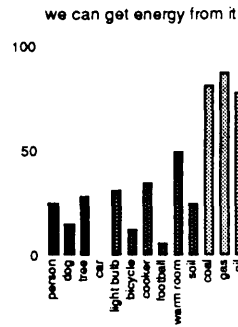
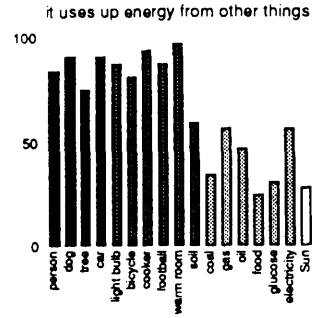
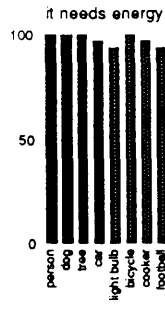
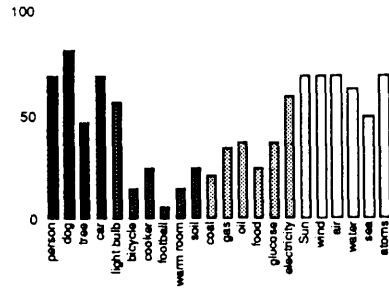
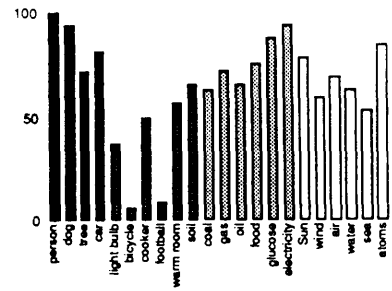

Figure 4 Percentages of 'yes' answers for entities: younger children

it can use up its own energy



it can store energy



it can lose energy

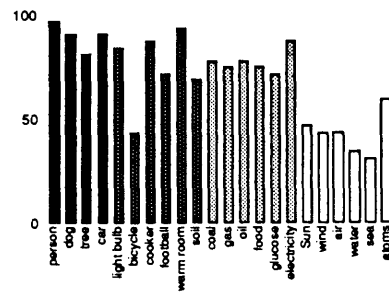

Key

- Living things
- Users
- Foods/fuels
- Sources

Figure 4 Percentages of 'yes' answers for entities: younger children (continued)

it needs energy

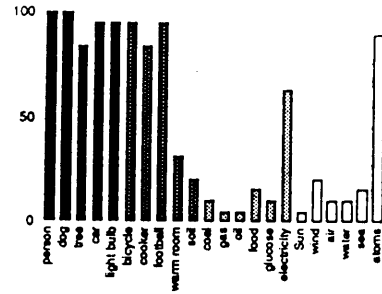

it uses up energy from other things

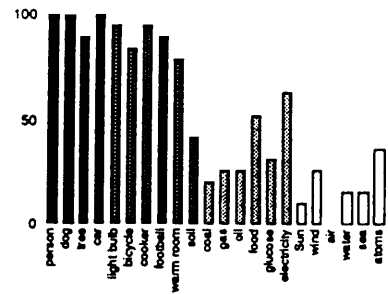

we can get energy from it

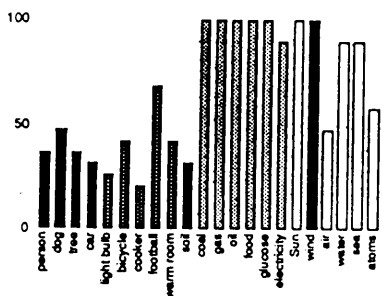

it can pass on energy

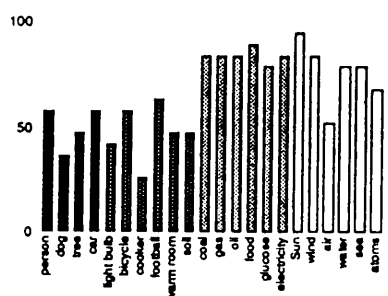

it is energy

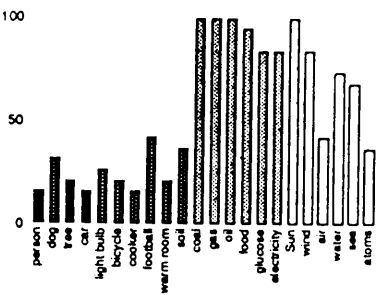

it can have energy

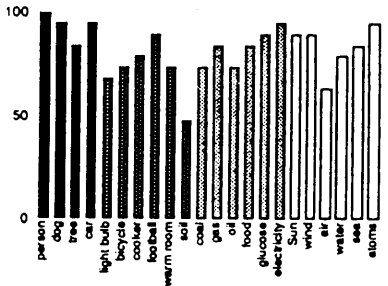

Figure 7 Percentages of 'yes' answers for entities: older children

Handwritten notes:
 person 100%
 dog 100%
 tree 100%
 car 100%
 light bulb 100%
 bicycle 100%
 cooker 100%
 football 100%
 warm room 100%
 soil 100%
 coal 100%
 gas 100%
 oil 100%
 food 100%
 glucose 100%
 electricity 100%
 Sun 100%
 wind 100%
 air 100%
 water 100%
 ice 100%
 atoms 100%

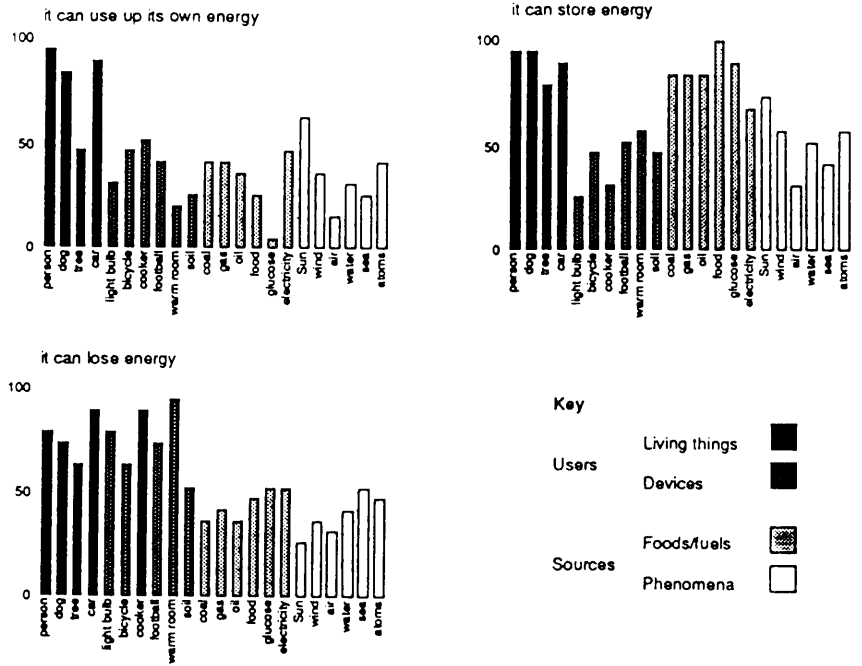

Figure 7 Percentages of 'yes' answers for entities: older children (continued)

APPENDIX 19

Multidimensional Scaling (MDS)

MDS solves the following problems: given a matrix of distances between all the pairs of a set of objects, constructs a map in n dimensions in which the locations of the entities reproduces as well as possible the given distances. For example, if the distances were those between towns in the USA, a reasonably good solution should be found for two dimensions, and a good one for three dimensions (because of the curvature of the Earth.)

The goodness of fit is estimated by the Kruskal Stress, which is the square root of the sum of the squares of differences between given and constructed distances, normalised by being compared with the sum of squares of differences between given distances and the mean distance between a pair.

The program may be instructed to treat the distances in various ways. They can be treated as Euclidean distances in a space, or other metrics can be imposed (for example, city block.) The minimal treatment is to ask for the map only to reproduce the relative ordering of the pairs of distances. This ordinal approach was used in the work reported here.

In application, a matrix of distances can be obtained in several ways. The most direct way is to ask subjects to estimate on some scale how "different" or "similar" pairs of entities seem to be. A second way it is used in the present work, is to obtain "distances" from the matrix of correlation between entities, found from some set of questions asked about each entity. The correlations were converted into "distances" by calculating $1 - \text{correlation}$.

The program can also be given more than one matrix distances for the same entities, obtained for example from different groups. It then finds the best comparison solution for the different groups, and examines the extent to which the several sets of distances given agree with the common solution. This is done by calculating how important each dimension of the solution is, for each group. The parameter "weirdness" measures how far a group's estimate of distances departs from the common estimate.