

F-SAR – DLR’S NEW MULTIFREQUENCY POLARIMETRIC AIRBORNE SAR

Ralf Horn, Anton Nottensteiner, Andreas Reigber, Jens Fischer, Rolf Scheiber

German Aerospace Center (DLR), Microwaves and Radar Institute,
P.O.Box 1116, 82230 Wessling, Germany
Tel: +49-8153-28-2384, Fax: +49-8153-28-1449, E-mail: ralf.horn@dlr.de

ABSTRACT

The Microwaves and Radar Institute of the German Aerospace Center (DLR) is known for consistent work on the field of airborne synthetic aperture radar and its application. In April 2008 the 20th anniversary of the maiden flight of the well-known E-SAR system was celebrated. E-SAR has been maintained well over the time. It provided valuable knowledge to the science community, especially in the past 10 years. However, it became more and more obvious that a technological renewal was inevitable. Consequently the development of a new SAR system was put on line under the name ‘F-SAR’.

Index Terms— F-SAR, E-SAR, Airborne SAR

1. DLR’S NEW AIRBORNE SAR

F-SAR identifies the successor of the well-known E-SAR system. The system is under development at the Microwaves and Radar Institute. The development was triggered by the demand for data being simultaneously acquired at different wavelengths and polarisations as well as by the demand for very high range resolution. E-SAR, the old system, cannot comply with these requirements due to technological limitations. F-SAR is a development utilising most modern hardware and commercial of the shelf components. As for E-SAR DLR’s Dornier DO228-212 aircraft is the first choice as platform for the new system (see Fig. 1).

1.1 F-SAR general system design features

F-SAR is designed to operate in X-, C-, S-, L- and P-bands with simultaneous all polarimetric capability and single-pass polarimetric interferometric capability in X- and S-bands.

Repeat-pass Pol-InSAR is a standard measurement mode. Range resolution is determined by the available system bandwidth. While components limit system bandwidth to 100MHz at P-band, a step-frequency approach is adopted to achieve up to 800MHz effective signal bandwidth at X-band to satisfy the requirement for very high resolution.

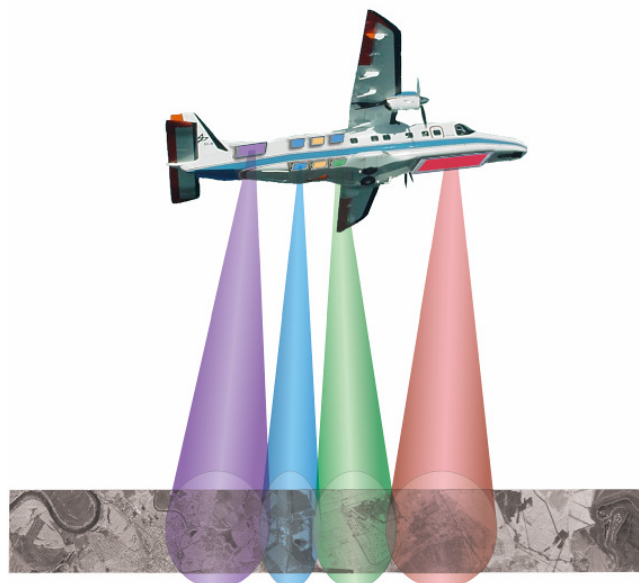

Figure 1 Artist’s view: F-SAR radar onboard DLR DO228 acquiring data simultaneously in X-, C-, L- and P-bands (X-blue, C-green, L-purple, P-red).

1.2. F-SAR instrument design overview

The F-SAR system comprises a basic system control and data acquisition sub-system to which individual RF subsystem modules are connected. System control is based on an Extended CAN bus and Ethernet concept. This gives the necessary flexibility and the degrees of freedom to configure the system optimally for carrying out the desired measurements and experiments like bistatic SAR for instance. Further, the concept makes the extension to any other RF band an easy task (see Fig. 2).

A special antenna mount (see Fig. 3) designed to fix planar array antennae to the aircraft is under development. Fully-fledged in multi-frequency configuration it holds seven right-looking dual polarised antennae: three in X-band, one in C-band, two in S-band and one in L-band. The P-band antenna is mounted under the nose of the aircraft as indicated in Fig. 1.

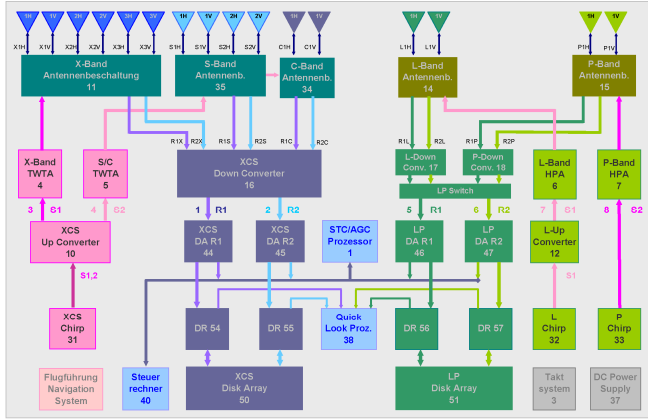

Figure 2 F-SAR system configuration for multi-frequency and polarimetric operation in X-C-S-L-P-bands including single-pass interferometric capabilities in X- and S-bands.

The antenna mount has the one important advantage that it makes it easy to change antenna configuration and to mount other antennae while avoiding individual airworthiness certification procedures the same time. The flight model has passed in-flight aerodynamic tests in 2008. The development and certification process is now continuing with adding means for lightning protection.

The nominal antenna configuration provides three single-pass interferometers: across track (XTI) in S-band and X-band, and along track (ATI) in X-band. The mechanical baselines are approx. 1.60m (XTI) and approx. 85cm (ATI). Special configurations, such as a GMTI antenna array in the top frame, are possible.

Main F-SAR technical parameters are given in Table 1.

Table 1 F-SAR technical characteristics

	X	C	S	L	P
RF [GHz]	9.60	5.30	3.25	1.325	0.35
Bw [MHz]	800	400	300	150	100
PRF [kHz]	5	5	5	10	10
PT [kW]	2.50	2.20	2.20	0.90	0.90
Rg res. [m]	0,3	0,6	0,75	1,5	2,25
Az res. [m]	0,2	0,3	0,35	0,4	1,5
Rg cov [km]	12.5 (at max. bandwidth)				
Sampling	8 Bit real; 1GS/500MS selectable; max number of samples 64k per range line; four recording channels				
Data rate	192MByte/s max (per rec. channel)				

For regular Earth observation purposes the radar covers an off-nadir angle range of 25 to 60 degrees at altitudes of up to 6000m above sea level, which is the maximum operating altitude with the DO228 aircraft. For special use other off-nadir angle ranges, like 60 to 85 degrees for long stand-off imaging or 0 to 25 degrees for sounding or steep incidence applications, can be realised technically.

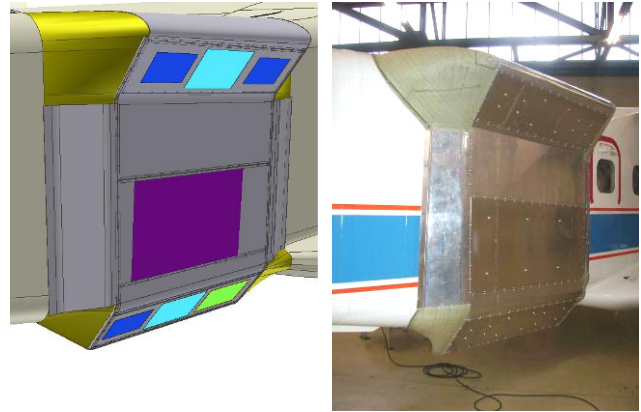

Figure 3 Schematic drawing (left) and flight model (right) of the F-SAR antenna mount with the nominal antenna configuration: 3 X-band (blue), 2 S-band (light-blue), C-band (light-green) and L-band (purple).

A central computer unit controls the radar via CAN bus and Ethernet (Fig. 4). The required synchronous timing and clock signals are generated in the main timing unit with less than 6ps jitter and rise times of less than 80ps. A 50MHz ultra-stable Quartz oscillator is the reference. The IGI DGPS/IMU based precision navigation system delivers a GPS 1PPS signal which regularly triggers an absolute time stamp in the raw data header. There are four modes of operation:

- System configuration
- System test
- Internal calibration
- Radar operation

In basic configuration the radar operates with four 1GS-ADCs. Each ADC unit has raw data formatting integrated. High speed data recording units are connected via optical fibre. A second optical fibre links the ADCs to the control computer (monitoring bus) for internal calibration and system monitoring.

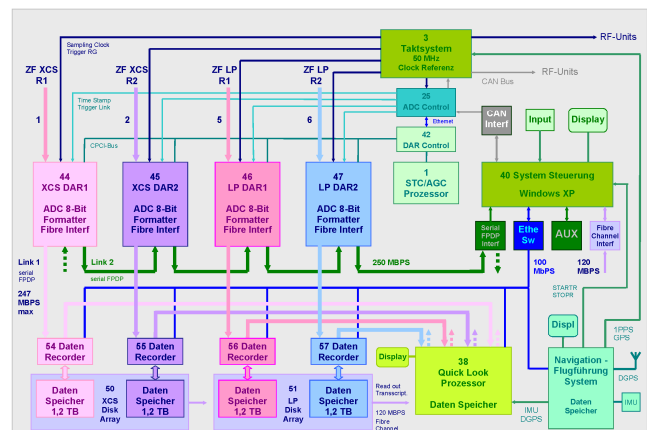

Figure 4 F-SAR system control and data acquisition sub-system block diagram.



Figure 5 F-SAR X-C-S-band system prior to installation onboard DO228 aircraft for flight testing.

A real-time processing unit is under development to date to deliver focussed SAR imagery online. It is being implemented via dedicated hardware and an optical fibre link to the data recording units. Offline operation will be possible as well.

F-SAR is in the building phase, which is set up as a sequence of steps. The radar back-end, i.e. system control and data acquisition modules, the X-band front-end section and the combined C-S-band radar modules are under flight test at the present (Fig. 5). L- and P-band sub-sections shall follow in 2009 and 2010. Once operational, F-SAR shall be controlled by two operators; one is responsible for the mission requirements, the other for the radar.

2. F-SAR PROCESSING ENVIRONMENT

The ground segment under development for F-SAR consists of a data transcription subsystem, a processing cluster and a storage system. It is configured for handling large data amounts at high throughput as the new radar is a very high data rate system.

To support the new radar also the well established repeat-pass interferometric SAR processor is undergoing a redesign to allow higher data throughput and simpler extension possibilities to accommodate new operating modes.

Attention is further given to the User Interface to allow operators of lesser background in airborne SAR processing and interferometry to generate the desired data products. The high level block diagram of the F-SAR processing structure is presented in Fig. 6. During F-SAR transcription the recorded radar raw data are split according to the different interferometric/polarimetric channels and are assembled into a RAW data product together with the associated navigation and auxiliary data. A data screener including a quick-look processing of the acquired data is part of this first processing step.

High resolution F-SAR data processing benefits from the many years of experience in processing repeat-pass

interferometric E-SAR data [1, 2]. However, most intensive processing modules are redesigned and coded in C++ to allow high throughput and parallelisation on different levels. Different channels of raw data can be processed in parallel on the computing cluster using PVM and inside the main computation modules thread based parallelisation is performed [3].

Radar geometry images (single-look complex and multi-look images) are assembled to the RGI data product, which includes special co-registered components to allow for straightforward interferometric combination of repeat-pass data. Depending on the evaluation purpose, different interferometric and/or polarimetric processing steps may follow. The RGI product is also the interface to advanced multi-channel SAR processing like e.g. differential interferometry or SAR tomography. GMTI processing applies to the RAW data directly [4]. For the generation of the geo-coded terrain corrected (GTC) product the geo-coding and mosaic S/W of the E-SAR system is adapted [5].

3. TEST FLIGHT RESULTS AND EXPERIMENTS

F-SAR performed the maiden flight in X-band in fall 2006. Flight testing is on-going since 2007. These tests included

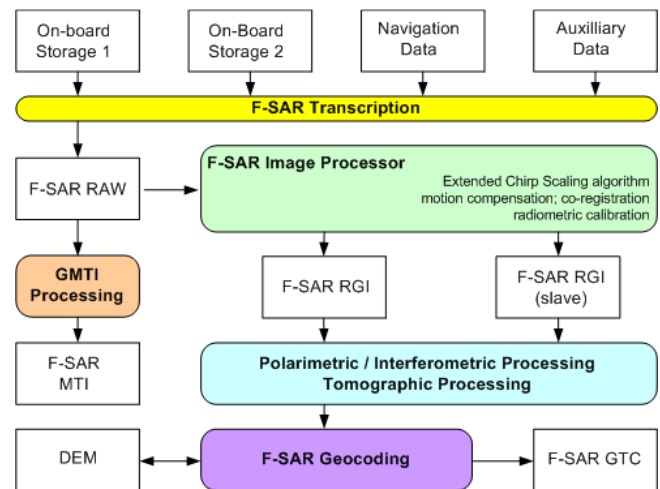

Figure 6 F-SAR processor block diagram.

GMTI experiments [4], TS-X underflights [6] and system calibration. Starting in 2008 the tests were extended to C- and S-bands and the simultaneous operation with X-band. A special antenna assembly was built and installed to support these measurements. Figures 7 to 9 show different image results obtained during recent test flights over the Kaufbeuren and Wallerfing test sites. The radar was operated at 300MHz and 384MHz bandwidth. The radar demonstrated a very good system performance measured on trihedral reflectors. We measured values of ISLR of about 16-20dB in range and azimuth. Geometric resolutions of 0.4m in range and azimuth single-look were obtained. A first performance analysis is presented in [7].



Figure 7 Zoom into an F-SAR quad-pol X-band image. Spatial resolution 0.4m. Site: Kaufbeuren, Germany.

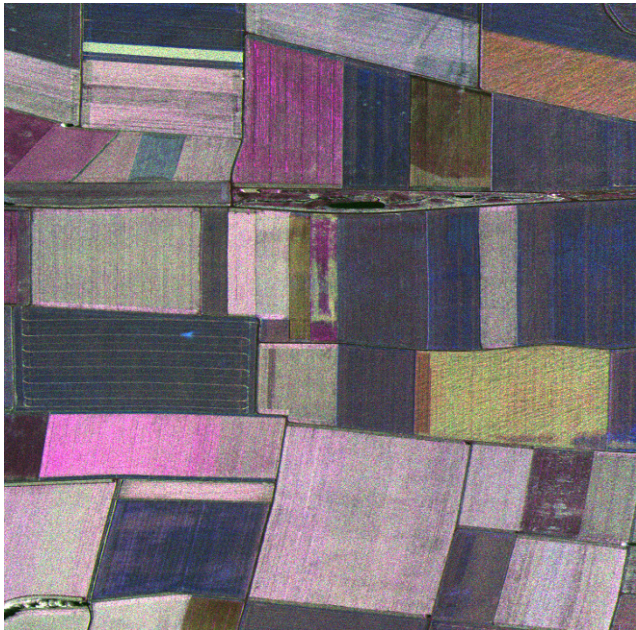

Figure 8 Zoom into an F-SAR quad-pol C-band image. Spatial resolution 0.4m. Site: Wallerfing, Germany.

4. ACKNOWLEDGEMENTS

F-SAR is a critical endeavour at the Institute. Its successful accomplishment relies on the enthusiasm, the commitment and the professional skills of the involved engineering and technical staff. The authors wish to thank especially Alberto Moreira, Sebastian Pasch, Gerhard Mueller, Bernd Gabler, Markus Limbach, Martin Keller, Jens Fischer, Christoph Dahme and Torben Keil (all DLR) as well as David Gómez



Figure 9 Zoom into an F-SAR quad-pol S-band image. Spatial resolution 0.5m. Site: Kaufbeuren, Germany.

Ortero and Christian Andres (formerly with DLR) for their excellent work and valuable contributions. Special thanks also go to the colleagues at the Institute's mechanical workshop and at DLR's flight facilities Oberpfaffenhofen, without those the realisation and testing of the new radar would not be possible.

5. REFERENCES

- [1] R. Scheiber, P. Prats et al., "Advances in Airborne SAR Interferometry Using the Experimental SAR System of DLR", Proceedings EuRAD, München, Germany, 2007.
- [2] R. Scheiber, I. Hajnsek et al., "Recent Developments and Applications of Multi-Pass Airborne Interferometric SAR using the E-SAR System", Proceedings EUSAR, Friedrichshafen, Germany, 2008.
- [3] Ch. Andres, T. Keil, R. Herrmann, R. Scheiber, "A multiprocessing Framework for SAR Image Processing", Proceedings IGARSS, Barcelona, Spain, 2007.
- [4] St. Baumgartner, M. Gabele et al., "Digital Beamforming and Traffic Monitoring Using the new F-SAR System of DLR", Proceedings International Radar Symposium, Berlin, Germany, 2007.
- [5] M. Bara, A. Broquetas, R. Scheiber, R. Horn, "Geocoding Techniques for Interferometric and Polarimetric Airborne SAR data", Proceedings EOS/SPIE Symposium on Remote Sensing, Barcelona, Spain, 2000.
- [6] S.V. Baumgartner, M. Rodriguez-Cassola et al., "Bistatic Experiment Using TerraSAR-X and DLR's new F-SAR System", Proceedings EUSAR, Friedrichshafen, Germany, 2008.
- [7] J. Fischer, St. Baumgartner et al., "Geometric, Radiometric, Polarimetric and Along-Track Interferometric Calibration of the new F-SAR system of DLR in X-Band", Proceedings EUSAR, Friedrichshafen, Germany, 2008.