

Optical Control of a GaAs Chip MMIC Amplifier at S Band

J.M. Zamanillo¹, J. Portilla², C. Navarro¹, C. Pérez-Vega¹ and A. Mediavilla¹

¹University of Cantabria, Communications Engineering Department (DICOM), Av. de los Castros s/n. 39005, Santander, Spain, Phone +34-942-200887

²University of Pais Vasco / EHU, Electricity and Electronic Department, Apdo 644. 48080, Bilbao, Spain, Phone +34-94-6015309

Abstract — This paper shows the results of research on the optical control of a GaAs chip monolithic amplifier, and is an extension of previous work by our group in the field of optical-microwave interaction [1-3]. The amplifier was originally designed for the transmitter stage of an indoor mobile communications system in the 2.4 GHz band. The possibilities of optical control of this amplifier are evidenced as follows: if the amplifier operates with the same biasing, the gain can be optically controlled from a condition of almost isolation, (small signal gain less than -5 dB), up to an active condition, (small signal gain greater than 10 dB), which gives a range of optical control of about 15 dB. At the same time, the optical control provides an improvement of the input and output matching in a range of 12dB and 6dB, respectively. This optical control suggests an interesting control of gain and matching for other microwave FET based active devices.

I. INTRODUCTION

The interest in the development of microwave optoelectronic systems has been increasingly stimulated because of the saturation of the microwave spectrum and the ability to integrate microwave and optical components into a single wafer, usually designed as OMMIC (Optical Microwave Monolithic Integrated Circuit). GaAs MESFET devices are one of the most commonly active devices used in microwave circuit design, and many researchers, including our group, have developed accurate MESFET models which include optical effects [1]. As far as we know, up to now there are only a few reports [2-3] about optical controlled microwave subsystems (amplifier, oscillator, active mixer, etc.), and therefore, this is the main reason because our group has taken interest on the electro-optical control of microwave devices, in particular, the MMIC amplifier presented in this paper.

The MMIC amplifier has been manufactured with the F20 technology from the GEC-Marconi foundry, and it is based on a GaAs MESFET transistor with a 0.5 μ m gate width. The use of this GaAs technology is clear if a comparison with silicon technologies is made: GaAs has a lower noise figure, faster speed and lower DC consumption. On the other hand, GaAs technology is more expensive than that of silicon. However, the actual tendency of the market is reducing this obstacle.

It is well known that when a GaAs FET is illuminated by a laser at a fixed wavelength, absorption effects take place at the gate-drain and gate-source inter-electrode spaces, and free carrier photo-excitation is induced at the active area level. In fact, AlGaAs P-HEMTs, as GaAs

MESFETs exhibit both photoconductive and photovoltaic effects [4-5]. This means that the static DC curves, as well as the small signal equivalent circuit parameters, change when optical energy is absorbed by the device.

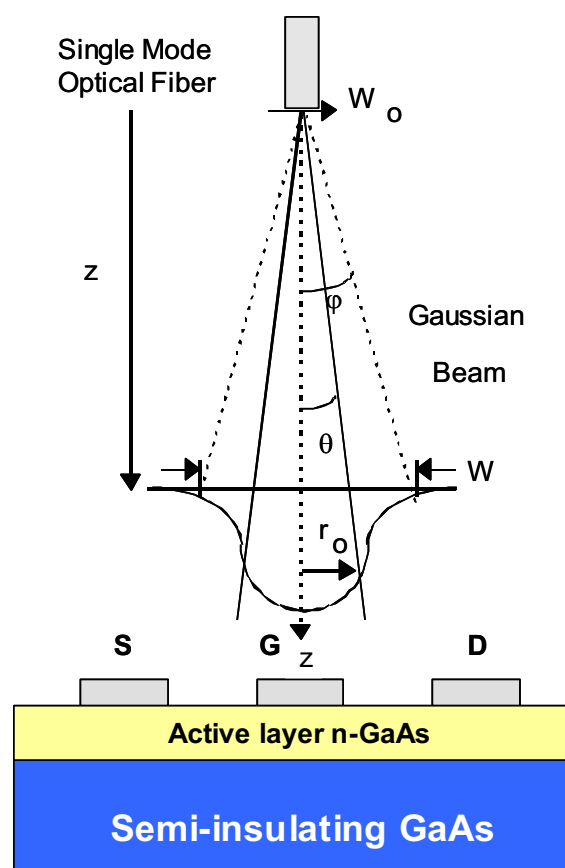

Fig. 1. Optical measurement set-up.

A detailed description of the measurement setup is given in [1]. Here we offer a brief explanation of this setup. The optical source is a laser diode ($\lambda=830$ nm), pigtailed to a single-mode optical fiber (5/125). The fiber is supported by an in-house fiber holder. From the optical fiber parameters, conditions are obtained for the far field Gaussian profile [1]. The Gaussian beam diameter at the fiber end is $W_o=3.1$ mm and the diffraction angle is $\phi=0.085$ rad. The optical energy distribution over the MESFET surface is not uniform, but we can take like effective region that where the 90% of the energy density is concentrated, as is shown in Fig.1.

The electrical diagram of the amplifier is shown in Fig. 2(a), and its microphotograph, in Fig. 2(b). The single stage amplifier designed, consists of a GaAs MESFET transistor with 6 fingers, and 175 μ m of gate width. To get the appropriate power, the matching has been realized with reactive passive networks, in order to simplify the circuit and minimize its size. The input network has a π configuration, while the output consists only of a hairspring inductor and a MIM capacitor.

Furthermore, it can be appreciated in the microphotograph, the necessary contact pads to place the coplanar test probes (RFIN and RFOUT), as well as DC biasing. This allows the device characterization directly with a coplanar probe station, model Cascade SUMMIT 9000. The final size of the amplifier including the pads is 1400 by 1050 microns.

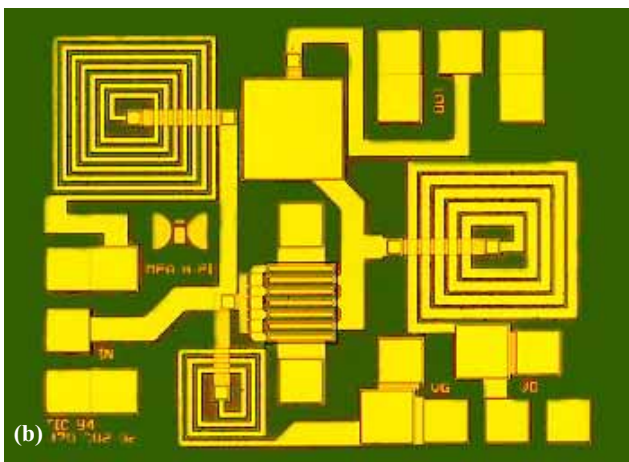
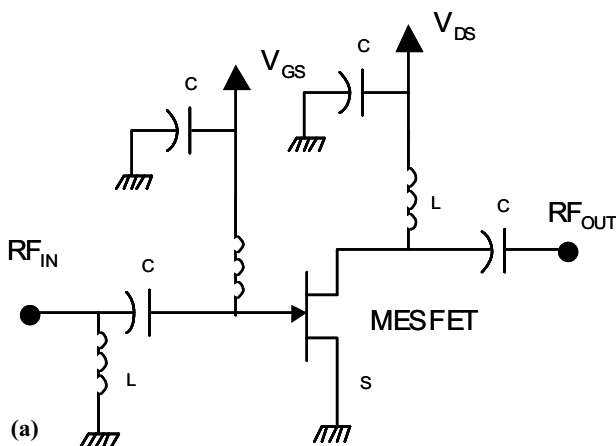

Fig. 2. (a) Electric scheme of the GaAs MESFET amplifier. (b) Microphotograph of the MMIC amplifier.

II. OPTICAL CONTROL OF MICROWAVE DEVICES.

In order to establish the accurate FET optical operation, preliminary experiments on the DC and pulsed I-V characteristics, along with S-parameter measurements under different optical powers, were performed for the transistor alone, but not for the complete amplifier [4-5].

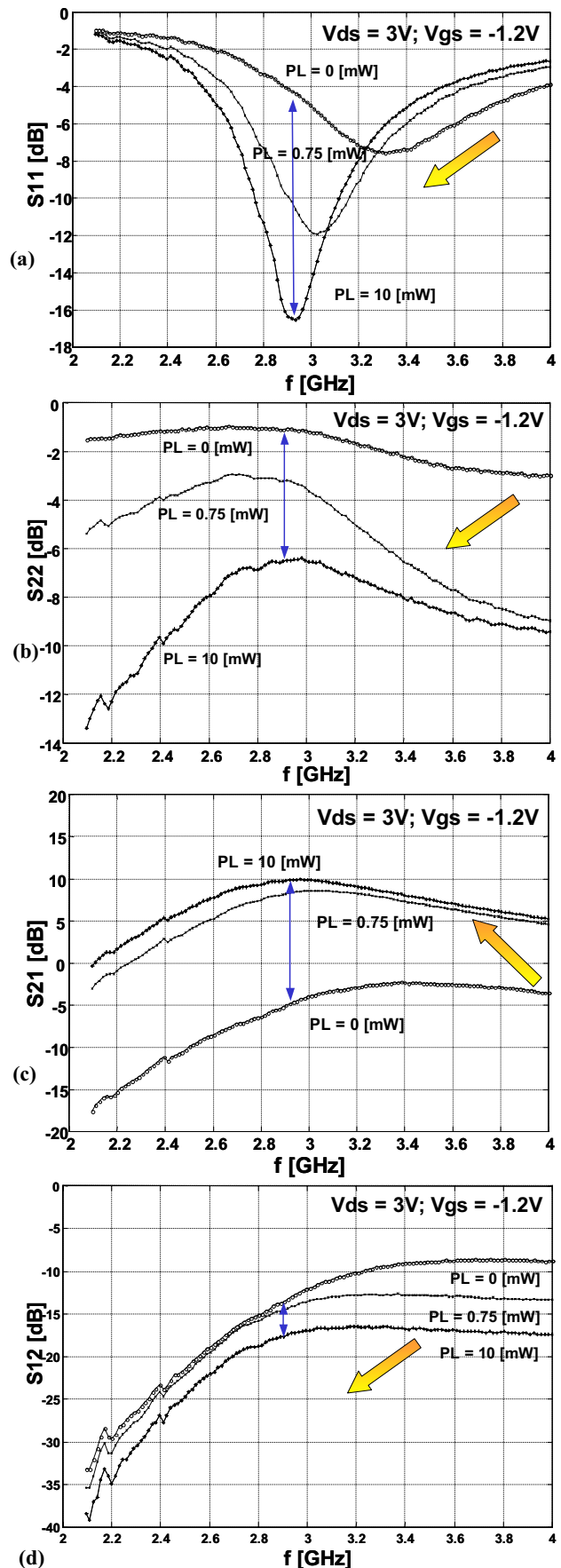

Fig. 3. Variation of the scattering parameters of the MMIC amplifier under the optical illumination. Arrow indicates the increasing of the optical power from darkness PL 0mW, 0.75mW and 10mW. (a) S11. (b) S22. (c) S21. (d) S12

Even when this amplifier was not designed for optical applications, it has enough optical coupling efficiency to observe this kind of interaction. When the laser spot is properly positioned over the transistor, and the bias point selected ($V_{gs} = -1.2$ V, $V_{ds} = 3$ V in our case), measurements of the amplifier scattering parameters in the band of interest (2-4 GHz) can be performed, as well as some of its main electrical characteristics, for example, input-output matching and small signal gain, can be evaluated as a function of the incident optical power on the transistor. The optical power range was changed from 0 mW (darkness) up to 10 mW. In this paper we only show results for three different values of optical power.

The variation of the scattering parameters for the amplifier studied here are shown in Fig 3, where an improvement in the small signal gain (S21) and the input-output matching variations (S11 and S22) can be observed. A deep increment in the input and output matching can be observed in Fig. 3 (a) and Fig. 3 (b). The improvement in S22 is clear (more than 8dB at 2.4 GHz), however for S11 only 3 dB of improvement has been reached at that frequency. At 2.9 GHz the improvement can be of up to 11 dB. Such improvement is produced because the amplifier has a mismatching design error in the input impedance at 2.4 GHz. The amplifier under non-illumination conditions, has better input match at 2.9 GHz than at 2.4 GHz, but under 10mW of optical power the matching is increased in the whole bandwidth (2-4 GHz). The improvement of 17 dB from dark conditions up to 10 mW of laser optical power applied in the S21 scattering parameter, as responsible of the small signal gain, is shown in Fig. 3 (c) when the amplifier is biased at $V_{gs} = -1.2$ V, $V_{ds} = 3$ V. The S12 parameter also has an improvement of 3dB at 2.9 GHz.

As a conclusion of this, we can say that when the amplifier is biased near the pinch-off region the effect of optical illumination is more significant than at other gate bias. This is a very interesting property for low consumption transceivers, because the user can increase the output power using optical signals, while in stand-by conditions, the device does not consume DC energy since the amplifier is near pinch-off and the battery charge can last more.

III. POWER MEASUREMENTS

A complete set of radiofrequency power measurements has been carried out for this MMIC amplifier. The influence of optical power PL applied to the device at several different bias points of the amplifier have been taken into account in this work. As examples of this kind of measurements, three different graphs are shown in Fig.4. Fig. 4 (a) shows the increment of RF output power of the amplifier versus different optical powers and the input RF power applied to the device, the bias pint of the amplifier is fixed to $V_{gs}=-1.2$ V, $V_{ds}=3$ V.

Fig. 4 (b) shows the overall increment of the output power as a function of the input power and several different gate voltages at 2.4 GHz and $V_{ds}=3$ V at the frequency of 2.4 GHz. A cuasi-logarithmic variation of

the output power P_{out} versus the optical power applied is observed.

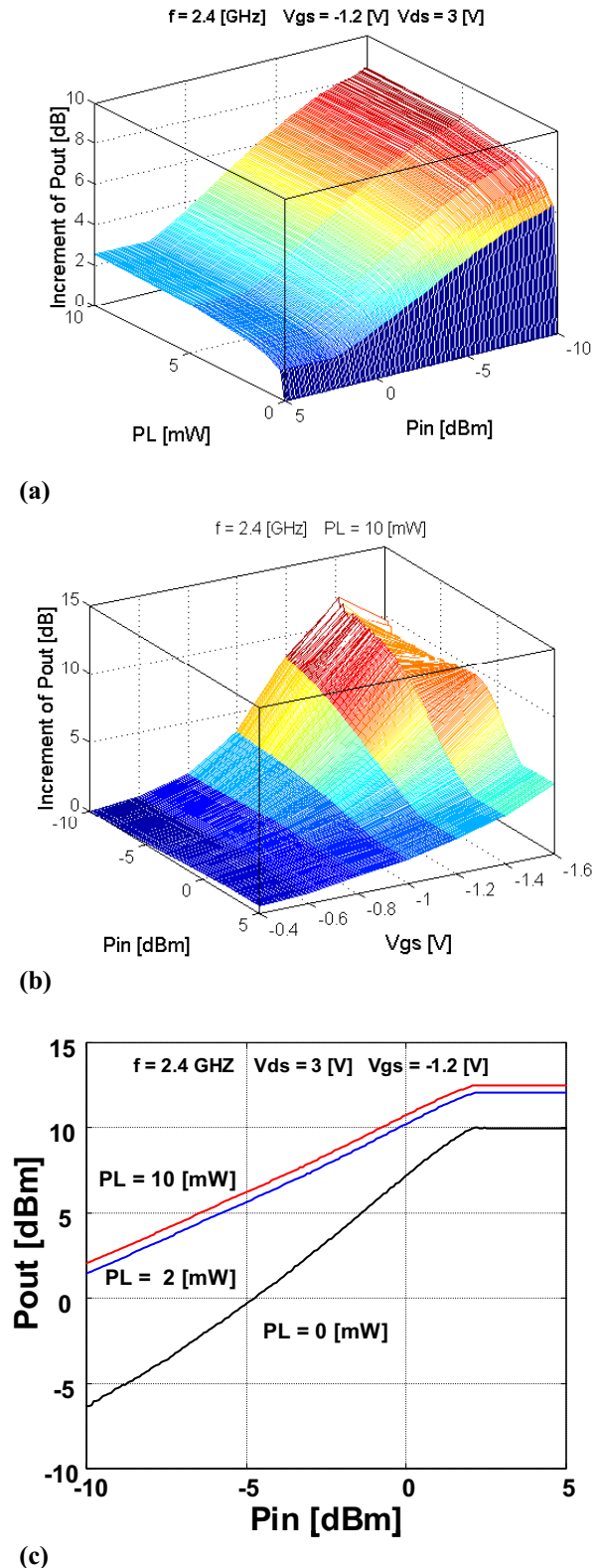

Fig. 4. (a) Incremental output power of the MMIC amplifier under 10mW of optical illumination at several different gate voltages.

(b) Incremental output power of the MMIC amplifier biasing at $V_{gs}=-1.2$ V, $V_{ds}=3$ V at several different optical powers.

(c) Pout vs. Pin curves at three different laser powers (0mW, 2mW and 10 mW).

Fig. 4(c) shows the P_{in} versus P_{out} curves at three different optical powers for the select bias point of $V_{gs}=-1.2V$, $V_{ds}=3V$ at 2.4 GHz.

IV. CONCLUSION

An exhaustive investigation of the control properties of a GaAs MMIC amplifier at S band under optical illumination has been performed. The main dependencies of its parameters, as well as the way of integrating their behavior into other classical controlling techniques for the drain and gate currents has been shown. The optical control procedure presented here is also valid for other types of microwave components and subsystems such as oscillators, mixers, up-converters, down-converters, etc. and this technique may improve the development of future generations of OMMICS. Results of this optical control will be reported by our group in future communications.

ACKNOWLEDGEMENT

The authors wish to acknowledge the assistance and support of the microwave and RF group of the department of Communication Engineering of the University of Cantabria.

REFERENCES

- [1] J.M. Zamanillo, C. Navarro, C. Pérez-Vega, A. Mediavilla, and A. Tazón "Large Signal Model Predicts Dynamic Behavior of GaAs MESFET Under Optical Illumination.". *Microwave and Optical Technology Letters*. Vol. 29 No.1, pp 25-31. April 5 2001.
- [2] A. J. Seeds, A. A de Sales, "Optical Control of Microwave Semiconductor Devices". *IEEE Transactions on Microwave Theory and Techniques*, Vol. 38, No. 5, 1990, pp. 577-585.
- [3] S. J. Rossek, C. E. Free, "Optical Control of Microwave Signals Using GaAs FETs". *Electronics and Communication Engineering Journal*, Febr. 1994, pp. 21-30
- [4] C. Navarro, A. Mediavilla, A. Tazón, J.M. Zamanillo, J.L. García, M. Lomer and J.M. López-Higuera. "An Accurate Photonic Capacitance Model for GaAs MESFET", *IEEE Transactions on MTT*, Vol 50, No. 4, pp 1193-1197, April 2002.
- [5] J. M. Zamanillo, C. Navarro, C. Pérez-Vega, J. A. García, A. Mediavilla and A. Tazón. "New Large Signal Model of AlGaAs P-HEMT and GaAs MESFET Under Optical Illumination". *GaAs 2002 European Gallium Arsenide, Applications Symposium Proceedings*, pp.121-124. Milan, Italy. Sept. 2002.
- [6] J.M. Zamanillo, C. Navarro, J. Sáiz-Ipiña, C. Pérez-Vega and A. Mediavilla. "New Large Signal Electrical Model of GaAs MESFET Under Optical Illumination". *GaAs 2001 European Gallium Arsenide, Applications Symposium Proceedings*, pp.167-170, London, Sept-2001.