

# ELECTROTHERMAL HARMONIC BALANCE SIMULATION OF AN INGaP/GaAs HBT BASED ON 3D THERMAL AND SEMICONDUCTOR TRANSPORT MODELS

R. Sommet, D. Lopez, R. Quéré

I.R.C.O.M. - C.N.R.S. U.M.R. n° 6615, I.U.T. G.E.I.I.,

7, rue Jules Vallès 19100 Brive la Gaillarde

[sommet@brive.unilim.fr](mailto:sommet@brive.unilim.fr)

## ABSTRACT

*A parallel implementation of the direct coupling of InGaP/GaAs HBT transport equations has been included in an Harmonic Balance simulator. Several results such as a class AB amplifier for mobile communication study and a stability analysis of “crunch effect” in multi-finger HBT have been performed.*

## INTRODUCTION

Circuit and device interaction determination appears to be one of the major challenge of mobile communication engineering in the next few years [1]. The ability of co-designing simultaneously devices and circuits will be a major feature of CAD tools for the design of MMIC circuits [2]. However, current simulation tools used to simulate the steady state of microwave circuits are based on the Harmonic Balance (HB) technique and require lumped models for the active devices which are not based on numerical solution of the semiconductor equations and as a consequence are not predictive. They require the active semiconductor components to be characterized in advance and fitted to a lumped equivalent model. The approach presented here deals with the integration of the physical system of semiconductor equations of a III-V HBT in a general circuit simulator [3].

## PARALLEL SIMULATOR

Thus, the popular HB formulation has been adopted in the proposed approach coupled to a fully implicit discretization scheme of one dimensional device equations. The resulting software allows the optimization of circuit performances in terms of physical and geometrical device parameters as well as in terms of terminating impedance's. This result has been achieved by making use of dedicated techniques for convergence improvement including the exact Jacobian matrix calculation of the nonlinear system that has to be solved [4]. In order for the simulator to be usable in term of CPU computation time, especially for multi finger HBT, we have realized a coarse grain parallel implementation of the simulator base on the scheme presented in figure 1. One “master” process solves by a Newton-Raphson iterative method the HB equations resulting from Kirchoff laws at each node of the global circuit. In order to get nonlinear current values and their derivatives versus applied commands, it sends requests to slave process which solve transport equations for each emitter finger and collects data currents and their derivatives to build the Jacobian matrix useful to convergence algorithm. The fact that computation time is mainly due to physical simulation implies that if we consider a “n” fingers amplifier circuit, the speedup is about “n” on the parallel machine compared to the serial machine. The actual implementation relies on a cluster of 9 PCs controlled by the LINUX operating system. A fast Ethernet HUB at 100 Mbits/s enables connection between each computer. The communication library between machines is based on the

standard MPI [5] providing a complete portability of the software. The feature of the complete parallel computer is about 1 GO of RAM and 20 GO of Hard Disk.

## RESULTS

Several results concerning a InGaP/GaAs HBT have been obtained. Figures 2 and 3 present first a comparison between simulated and pulsed measurements characteristics for a one finger  $2\mu\text{m} * 30\mu\text{m}$  HBT. We can see a good agreement between measurements and models which first validate our one dimensional DD approach.

Results concerning the optimization of a class AB power amplifier for mobile communication at 1.8 GHz have already been presented in [3] and are just remember here. With the actual coupling method, optimization of the amplifier becomes feasible in terms of device characteristics or embedding impedance's for a particular device as the total CPU time required for the simulation of the steady state regime takes less than 4 min per power point. Moreover complementary results such as internal carrier densities evolution inside the device during the loadline cycle may be extracted which is very interesting for the co-design of circuits and active components

The second kind of results concern the study of thermal instability on multi fingers HBT. We have simulated the “crunch” effect which appears in a 2 or more fingers HBT. Figure 4 exhibits first the  $I_c$  curve versus  $V_{be}$  for fixed  $V_{ce}$  corresponding to the thermal solution of the DD for one finger. The two possible solutions for a given  $V_{be}$  and a fixed  $V_{ce}$  value show the potential instability for the  $I_c$  current. The schematic of the simulated circuit is presented in figure 5. A probe generator is introduced in order to force a temperature gap between finger 1 and finger 2. The solution is computed for several values of  $V_{probe}$  until  $I_{probe}$  equal zero is reached meaning that the probe generator do not perturb the steady state equilibrium [6]. Figure 6 shows the current  $I_c$  in each transistor. For  $V_{ce}$  greater than about 4V the temperature in each transistor vary. The current in the hot finger increases rapidly whereas this of the cold one decreases. Some results concerning a study of the effect of the ballast resistor  $R_{e_{ext}}$  and the thermal resistor  $R_{th}$  in the two fingers HBT have been realized.(an internal integrated ballast layer is already present in the transistor). They will be presented at the conference. The shift of critical  $V_{ce}$  where the “crunch” phenomena appears is compatible in each case with the Liu formula (1) [7].

$$V_{ce \text{ crit}} = 1/\phi R_{th} * (\eta kT/qI_c + r_e) \quad (1)$$

The originality of the implemented electrothermal model relies also on the way the thermal network is obtained. A three dimensional thermal analysis is performed first with the Finite Element software MODULEF. A cutplane of the HBT 3D mesh is presented in figure 7. Then the thermal resistor network is extracted according the temperature profile. This thermal network is composed by linear elements such as finger thermal resistor and thermal coupling resistor. The second stage will consist of integrating more precisely thermal effects by means of model reduction technique applied to the K rigidity and the M stiffness matrix provide by the finite element software.

## CONCLUSION

We have presented a parallel implementation of the direct coupling of InGaP/GaAs HBT transport equations in an Harmonic Balance simulator which enable to study power amplifier for mobile communication and thermal stability analysis of “crunch effect” in multi-finger HBT. Moreover the thermal resistor network is extracted from 3D thermal analysis. This simulator is a large step to a full physical coupled simulator with predictive capabilities.

## REFERENCES

- [1] **R.W. DUTTON, Z. YU** "Architecture of TCAD For High Frequency Application" Workshop on Nonlinear CAD MTT-S 96, San Fransisco, June 17 1996, pp 2-26.
- [2] **Z. YU, R. W. DUTTON** "Large Signal Analysis of RF Circuits in Device Simulation" Workshop on Nonlinear Modeling and Characterization of Microwave Devices MTT-S 99, L. A., June 1999.
- [3] **R.SOMMET, Y. PERREAL, R.QUERE** "A direct coupling between the semiconductor equations describing a GaInP/GaAs HBT in a circuit simulator for the co-design of microwave devices and circuits" GaAs 97 – Bologna, sept. 1997
- [4] **R. SOMMET, E. NGOYA** "Full Implementation of Implicit Nonlinear Model with Memory in an harmonic Balance Software", IEEE on Microwave and Guided Letters, Vol. 46, n° 7, june 1997
- [5] **M. SNIR, S.OTTO, S. HUSS-LEDERMAN, D. WALKER, J. DONGARRA** "MPI : The Complete Reference", The MIT Press, Massachusetts London, England 1996
- [6] **T. PEYRETAILLADE, M. PEREZ, S. MONS, R. SOMMET, Ph. AUXEMERY, J.C. LALAUERIE, R. QUÉRE** "A Pulsed-Measurement based Electrothermal Model of HBT with Thermal Stability Prediction Capabilities" IEEE, MTT-S 97, DENVER, june 1997
- [7] **W. LIU, A. KHATIBZADEH** "The Collapse of Current Gain in Multi-Finger Heterojunction Bipolar Transistors : its Substrate Temperature Dependence, Instability Criteria, and Modelling", IEEE Trans. On Electron Devices N° 10, oct.1994

## FIGURES

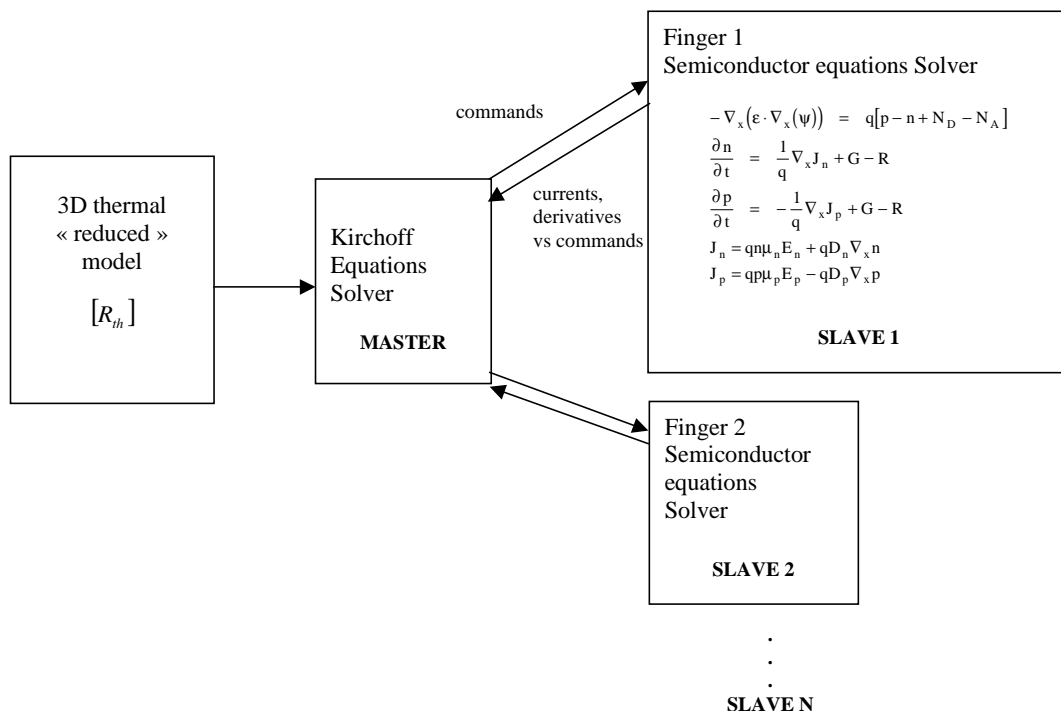

Figure 1 : Implementation of the parallel circuit simulator

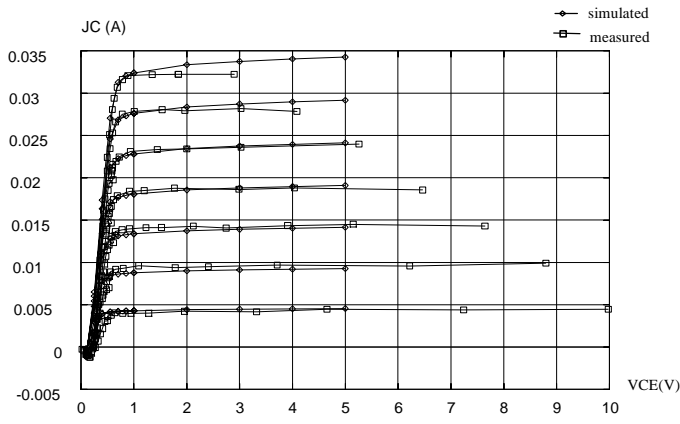

Figure 2 : Simulated and measured output characteristics  $I_c(V_{ce})$

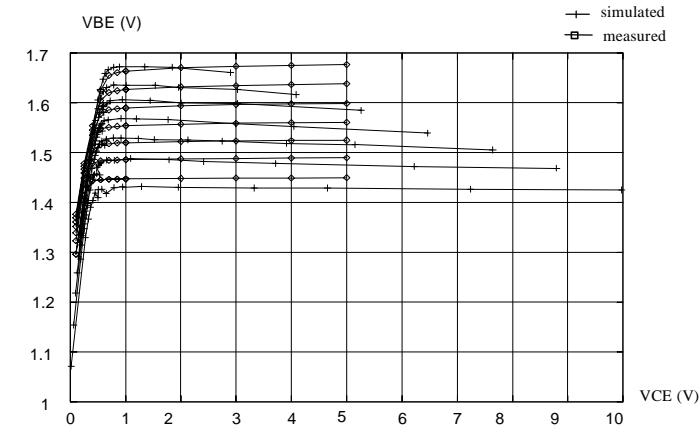

Figure 3 : Simulated and measured input characteristics  $V_{be}(V_{ce})$

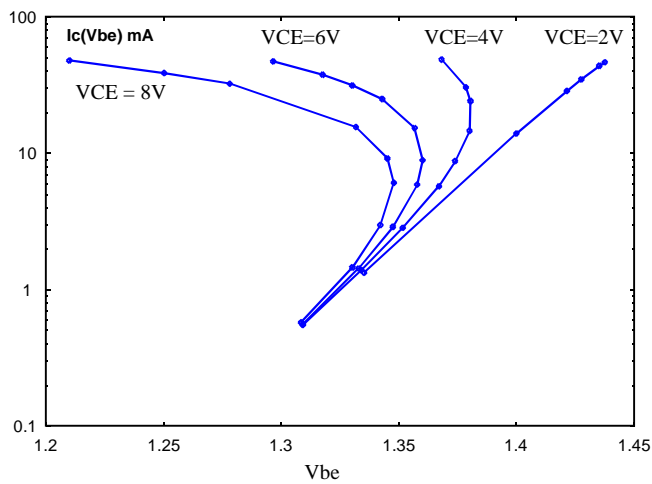

Figure 4 :  $I_c(V_{be})$  characteristic for one finger

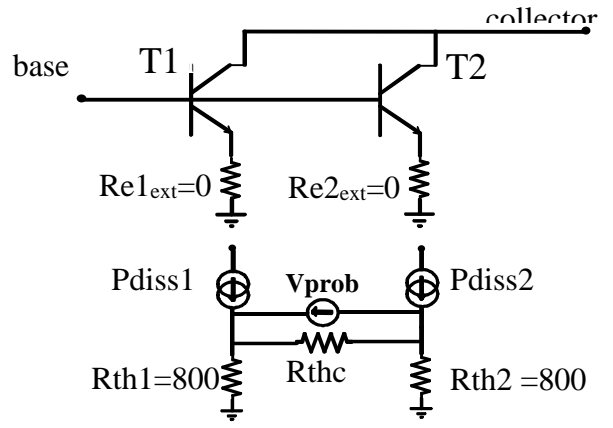

Figure 5: Two fingers HBT and its thermal circuit

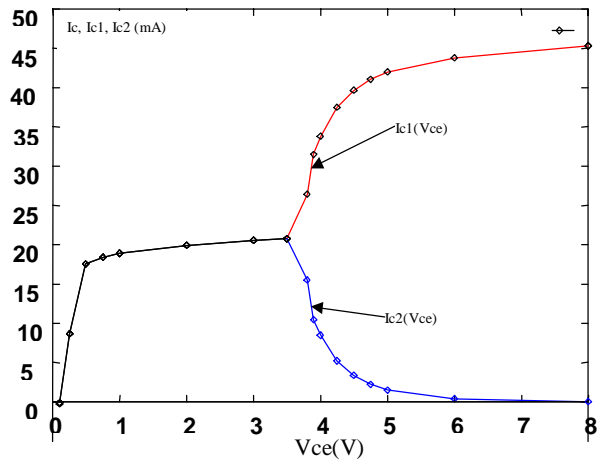

Figure 6: Collector currents versus  $V_{ce}$

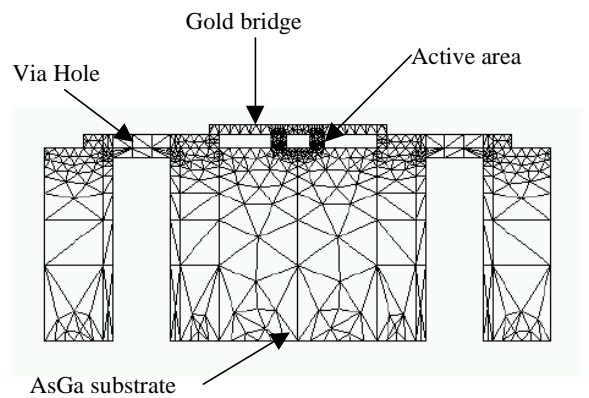

Figure 7 : Cutplane of the HBT 3D mesh