

# A Non-Linear Statistical Model for GaAs FET Integrated Circuits

F. Centurelli\*, A. Di Martino\*\*, P. Marietti\*, G. Scotti\*, P. Tommasino\*, A. Trifiletti\*

\* Electronic Engineering Department, University of Rome "La Sapienza",  
Via Eudossiana 18, I-00184, Roma, ITALY. Phone: +39 06 44585679, Fax: +39 06 4742647,  
e-mail: [trifiletti@die.uniroma1.it](mailto:trifiletti@die.uniroma1.it)

\*\* STMicroelectronics, Stradale Primosole, 50 I-95121 Catania – Italy

*A new statistical non-linear model of GaAs FET MMIC's which allows to represent distance-dependent technological parameter variations by means of equivalent circuit parameters is presented. An automatic procedure to extract the statistical model parameters from a database of DC and S-parameter measurements has been developed. The procedure performs the extraction of the covariance matrices of two FET devices at different mutual distances and uses them to build the multi-device MMIC covariance matrix. Capability to reproduce statistical distribution has been successfully checked by performing hypothesis tests of equivalence on S-parameters at different distances in the 1-50 GHz frequency range.*

## INTRODUCTION

MMIC design with short-length III-V technologies requires accurate statistical models to represent electrical performance variations of active devices due to process parameter dispersions. Availability of statistical model libraries allows the use of yield-oriented design techniques, e.g. see Cooke and Purviance (1) or Scotti et al (2), such as the design centering reported by Purviance and Meehan (3), to evaluate and optimise circuit yield. Several statistical models have been developed in last years, based on empirical equivalent circuits of MESFET and HEMT devices, and Principal Component Analysis (PCA) has been proposed by Swidzinski and Chang (4) to develop a non-linear uncorrelated empirical statistical model. The procedure permits to accurately reproduce means, standard deviations, correlations, and non-linear relationships among S-parameters in a given bias point. The authors address the necessity of model extension to cover bias-dependency, and outline the extraction strategy for bias-dependent non-linear statistical models. A non-linear statistical characterisation of GaAs HEMT devices was presented by Centurelli et al (5) in which the covariance matrix elements of the model were considered as functions of the distance between devices. Here, a new non-linear empirical statistical model of a given MMIC composed of FET devices is presented. The correlation coefficients of the parameters of different active devices are considered as a function of the circuit topology (i.e. the mutual distance of the FET devices in the MMIC), so determining an empirical non-linear model in which the on-chip correlation of process parameters is accounted.

## THE MMIC STATISTICAL MODEL

The statistical model of the MMIC comprises a nominal non-linear model for the single device and a covariance matrix which accounts for statistical correlation among the active devices as a function of their mutual distances on the MMIC. The nominal model is composed of a set of not bias-dependent parameters (i.e. the extrinsic parameters, the capacitor  $C_{dc}$ , and the channel transit time  $\tau$ ), and a set of empirical non-linear functions ( $I_{dsDC}$ ,  $I_{dsRF}$ ,  $C_{gs}$ ,  $C_{ds}$ ,  $C_{gd}$ ,  $R_i$ ) of the instantaneous voltages  $V_{gs_i}$  and  $V_{ds_i}$ , as shown in Fig. 1. The statistical non-linear model of the device is composed of both the nominal model and a set of correlated gaussian variables, listed in Tab. 1. A sensitivity analysis of the functions  $I_{dsDC}$ ,  $I_{dsRF}$ ,  $C_{gs}$ ,  $C_{ds}$ ,  $C_{gd}$ ,  $R_i$  versus their empirical parameters, has been carried out to choose the  $M$  empirical parameters to be considered as random variables. The statistical non-linear model of an MMIC containing  $N$  FETs, comprises  $N \cdot M$  random variables.

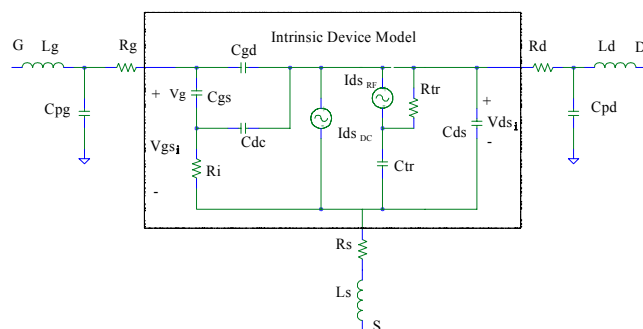

Figure 1: Non-linear equivalent circuit of the FET device

**Table 1**  
**Random variables of the statistical non-linear model**

<b>l<sub>pk</sub></b>	DC current amplitude factor
<b>V<sub>pk0</sub></b>	V <sub>gs</sub> for maximal DC transconductance
<b>d</b>	V <sub>pk0</sub> linear factor versus V <sub>ds</sub>
<b>u</b>	DC output conductance
<b>l<sub>pk1</sub>, l<sub>pk2</sub></b>	RF transconductance amplitude factors
<b>l<sub>pk3</sub>, l<sub>pk4</sub></b>	RF output conductance amplitude factors
<b>Q<sub>ogs</sub></b>	C <sub>gs</sub> amplitude factor
<b>Q<sub>ods</sub></b>	C <sub>ds</sub> amplitude factor
<b>Q<sub>ogd</sub></b>	C <sub>gd</sub> amplitude factor

In commonly used CAD models, no correlation is considered between parameters of different devices, so neglecting distance-depending correlation between devices on the same chip. Here, we propose a new statistical model composed of a  $(N \cdot M) \times (N \cdot M)$  covariance matrix ( $M=11$ ) in which the cross-correlation between parameters of two different devices is a function of the mutual distance between them. In the next Section, a procedure to extract model parameters from a population of measured devices will be presented.

## THE EXTRACTION PROCEDURE

The statistical model of a MMIC composed of several FET devices is extracted from a database of  $I_{ds}$  and S-parameter measurements performed on a test-chip containing devices with the same geometry. A critical step in MMIC model extraction is the use of optimisation routines for the evaluation of the statistical non-linear model of the single device. Large multidimensional error functions produce several local minima close to the global minimum, and the algorithm could not properly converge to the global minimum. Therefore, we have used decomposition-based optimisation algorithms, as proposed by Van Niekerk and Meyer (6), and a proper selection of the empirical statistical parameters to extract the nominal model of the active device. Both the not bias-dependent parameters and the fitting parameters of the non-linear functions in the model, are extracted with an automatic procedure, which makes use of custom Simulated Annealing (SA) and Gradient optimisation routines. The overall extraction procedure of the MMIC model is shown in Fig. 2 and will be now described in details.

### FET Nominal Model Extraction

The non-statistical empirical parameters of the model are determined by extracting a non-linear model for the device at the centre of the chip. Then, a database of DC and RF non-linear models is extracted for each transistor on the test-chip different from the centre device, by optimising the statistical parameters and taking the non-

statistical parameters unchanged. A decomposition-based optimisation routine has been used to determine the four parameters of the static empirical function  $I_{ds,DC}$ . Then, mean values and standard deviations of the fitting parameters considered as statistical variables are evaluated from the database of non-linear models. Finally, the nominal model of the single device is obtained substituting in the preliminary nominal model the mean values calculated for the statistical parameters.

### Distance-Dependent Covariance Matrix Evaluation

The set of all possible distances  $d_i$  between devices on the test-chip is determined and, for each distance, a database  $DB(d_i)$  is built comprising all couples of non-linear models for devices at distance  $d_i$ . The database  $DB(d_i)$  is used to calculate the correlation matrix of two devices at distance  $d_i$ , and in particular the cross-correlation block  $C^{Mod}(d_i)$  (5). The auto-correlation block  $C^{Mod}(0)$  is considered to be identical for each distance and evaluated from the database  $DB(0)$  comprising the non-linear models of all the devices on the test-chip.

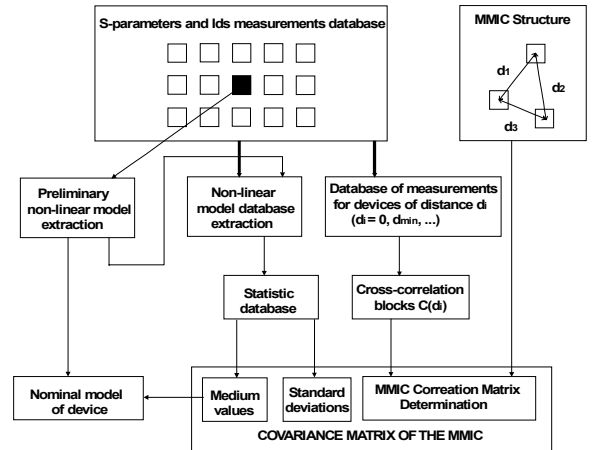

Figure 2: Extraction procedure algorithm of the MMIC statistical model

### MMIC Covariance Matrix Evaluation

The correlation matrix of a given MMIC in which the maximal distance between two devices is  $d_{max}$ , is determined as follows: the diagonal blocks of the matrix are the  $C^{Mod}(0)$  auto-correlation blocks, the cross-correlation block between the devices  $T_j$  and  $T_k$  is the block  $C^{Mod}(d_i)$  corresponding to the distance  $d_i$  on the test-chip closer to the distance  $d_{j-k}$  between  $T_j$  and  $T_k$ .

## THE VALIDATION PROCEDURE

Validation of the MMIC statistical model extraction procedure has been performed by comparing the covariance matrix of test-chip measured S-parameters to

the one obtained from the statistical model at each frequency and for several distances  $d_i$  between transistors. Here, the hypothesis testing procedure described in (7) has been used to check equivalence between mean values, standard deviations, and both the auto-correlation and the cross-correlation blocks of the statistical populations. In particular, the hypothesis has been checked that the correlation coefficients  $c_{im}^{Meas}(d_i)$  (for the measured database) and  $c_{im}^{Mod}(d_i)$  (for the model database) for transistors  $T_i$  and  $T_j$  at distance  $d_i$  are statistically equivalent with a significance level  $\alpha$  and a given tolerance factor  $\epsilon$ :

$$|c_{im}^{Meas}(d_i) - c_{im}^{Mod}(d_i)| < \epsilon \quad (1)$$

The same tests to check equivalence of measured and modelled mean values and standard deviations, and a test to check the sign of corresponding correlation coefficients have been also performed. In order to perform extraction algorithm validation without fabricate and measure large test-chips, a procedure to get a database of measurements of a simulated NxN test-chip from measurements performed on a single device is presented. As a first step, the non-linear model is extracted from Ids and S-parameters measurements of the starting device; then, a non-linear model comprising a set of values for the statistical variables, considered as a sample of a multivariate gaussian variable, is determined for each transistor of the test-chip. Finally, the static Ids current and S-parameters are calculated for each device and used to perform the MMIC model extraction and validation.

## RESULTS

Validation procedure has been performed starting from Ids and S-parameters data stored in a 10x10 database of GaAs HEMT device measurements. The database has been built starting from measurements performed on a single device of PHILIPS PML-D02AH monolithic process, as reported in the previous Section. The statistical model has been extracted from the database and inserted in Agilent ADS CAD tool. A Monte Carlo analysis has been performed at  $V_{gs} = -0.2$  V,  $V_{ds} = 3$  V. The correlation matrices of devices at distance  $d_1 = d_{min}$  (the reticular distance of the test-chip) and  $d_2 = 2*d_{min}$  for the extracted model have been evaluated and compared to the ones obtained from the database. A cumulative level of significance  $\alpha = 0.1$  has been considered to perform statistical hypothesis tests for the real and the imaginary parts of S-parameters in the 1-50 GHz frequency range. Hypothesis of a percentage error between measured and modelled S-parameters lower than a given amount has been checked for the 8 mean values and the 8 variances; an error lower than 0.35 has been checked for the 28 auto-correlation and the 36

cross-correlation coefficients. The amount of percentage error between measured and modelled mean values and variances which allows the statistical test to be passed in 50 % and 75 % of the cases are reported in Tab. 2. The auto-correlation coefficients are statistically equivalent with an error lower than 0.35 in 67 % of cases and the same sign has been found in 87 % of the cases. Comparison between some auto-correlation coefficients is shown in Fig. 3. The cross-correlation coefficients for  $d = d_1$  and  $d = d_2$  are statistically equivalent with an error lower than 0.35 in 84 % and 94 % of cases, respectively. The same sign has been found in 87 % and 92 % of the cases. In Fig. 4 comparison between some cross-correlation coefficients for  $d = d_1$  and  $d = d_2$  is shown.

**Table 2**  
Percentage difference between measured and modelled parameters needed to obtain a 50 and a 75 percentage of success for statistical test performed on S-parameters in 1-50 GHz band

	50 % of success		75 % of success	
	Mean	Variance	Mean	Variance
Re[S <sub>11</sub> ]	2 %	38 %	5 %	39 %
Im[S <sub>11</sub> ]	1 %	38 %	1 %	38 %
Re[S <sub>12</sub> ]	2 %	36 %	3 %	49 %
Im[S <sub>12</sub> ]	2 %	37 %	7 %	38 %
Re[S <sub>21</sub> ]	3 %	35 %	7 %	36 %
Im[S <sub>21</sub> ]	2 %	35 %	3 %	38 %
Re[S <sub>22</sub> ]	2 %	36 %	4 %	44 %
Im[S <sub>22</sub> ]	1 %	35 %	1 %	42 %

## CONCLUSIONS

A non-linear statistical model of GaAs FET MMICs has been developed, in which a multivariate distance-dependent gaussian distribution is assumed for model parameters. An automatic procedure to extract MMIC model from measurements performed on a test-chip has been also presented. Results have shown that the proposed methodology is able to model S-parameter populations of a given MMIC with high level of statistical significance. Hypothesis tests have highlighted statistical equivalence between measured and modelled populations with 0.1 cumulative level of significance, and encourage the use of the model to evaluate and optimise MMIC yield.

## REFERENCES

- (1) R. Cooke and J. Purviance, *Statistical Design for Microwave Systems*, Proc. IEEE MTT Symp, pp. 679-682, 1991
- (2) G. Scotti, P. Tommasino, A. Trifiletti, *Bias Correction and Yield Optimisation of MMIC's with*

- (3) J. Purviance and M. Meehan, *CAD for Statistical Analysis and Design of Microwave Circuits*, Int. Journal of Microwave and Millimeter-Wave Computer-Aided Engineering, Vol. 1 pp. 59-76, 1991
- (4) J.F. Swidzinski and K. Chang, *Nonlinear statistical modeling and yield estimation technique for use in Monte Carlo simulations*, IEEE Trans. Microwave Theory and Techniques, Vol. 48 pp. 2316–2324, Dec. 2000
- (5) F. Centurelli, A. Di Martino, P. Marietti, G. Scotti, P. Tommasino, A. Trifiletti, *A New Procedure for*
- (6) C. van Niekerk, and P. Meyer, *Performance and Limitations of Decomposition-Based Parameter-Extraction Procedures for FET Small-Signal Models*, IEEE Trans. Microwave Theory and Techniques, Vol. 46 pp. 1620-1627, Nov. 1998
- (7) A. O. Allen, *Probability, Statistics, and Queueing Theory with Computer Science Applications*, Boston: Academic Press, 1990

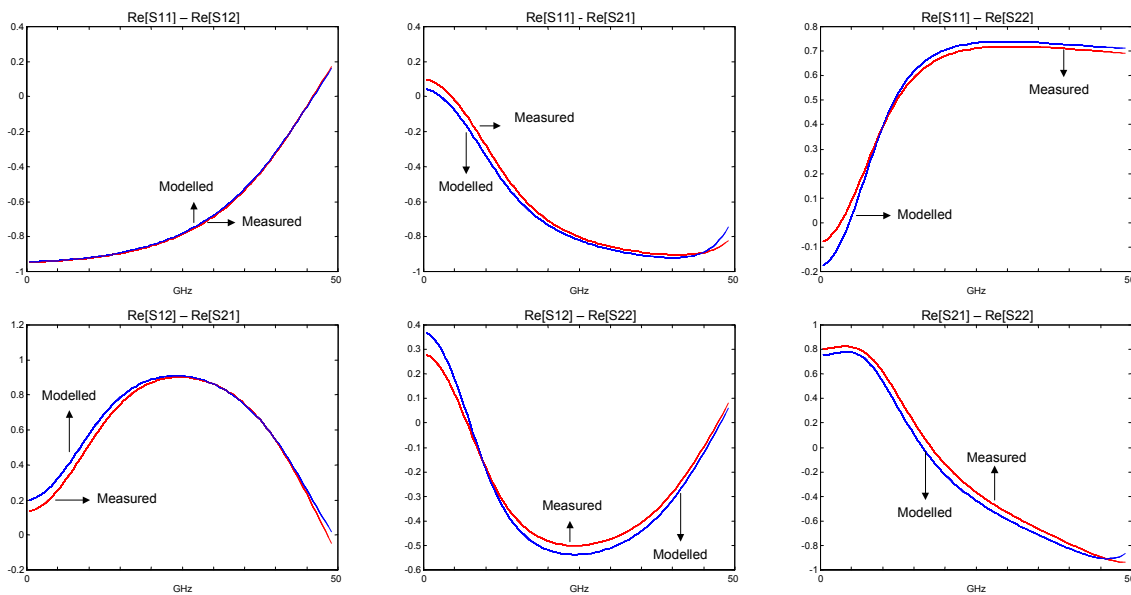

Figure 3: Auto-correlation coefficients of S-parameters' real parts for measured data and model

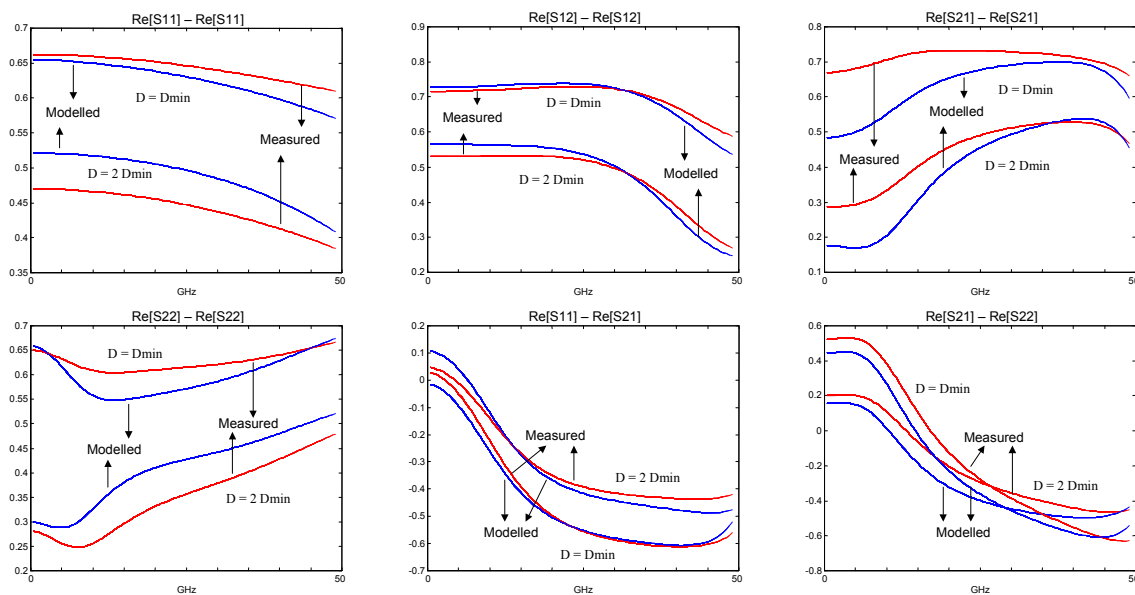

Figure 4: Cross-correlation coefficients of S-parameters' real parts for measured data and model