

A DC OFFSET CONTROLLER FOR TRANSFORMERLESS SINGLE PHASE PHOTOVOLTAIC GRID-CONNECTED INVERTERS

L. Bowtell and A. Ahfock

Abstract –

Limitation of DC injection into the AC network is an important operational requirement for grid-connected photovoltaic systems. One way to ensure that this requirement is met is to use a power transformer as interface to the AC network. But this adds costs, mass, volume and power losses. In a transformerless system, the inverter forming part of the photovoltaic system has to be operated so that DC content in its output current is below specified limits. Ideally there should be no DC at the output of the inverter, but in practice, in the absence of special measures, a small amount of DC current is present. A technique for elimination of the DC offset is proposed. It is based on the sensing of the DC offset voltage at the output of the inverter. The sensor output is used to drive a feedback system designed to control operation of the inverter so that the DC offset is forced to stay within acceptable limits. A mathematical model for the DC offset controller is derived. A design procedure, based on the model, is proposed for the controller. Results of tests performed on a system of 1kW nominal rating, provides validation for the mathematical model.

1. INTRODUCTION

Dispersed generation typically involves conversion from DC to AC. Grid-connected photovoltaic (PV) systems, on which this paper focuses, are well-known examples. They require an inverter to convert DC from solar panels to AC. Ideally the output current of the inverter will be purely AC, but in practice, unless special measures are taken, it will contain a small amount of DC. Injection of DC into the AC mains, if excessive, can lead to problems such as corrosion in underground equipment [1], transformer saturation and transformer magnetising current distortion [2] and malfunction of protective equipment [3]. Therefore guidelines and standards have been set up to regulate DC injection [4]. For example Australian Standard AS4777.2 limits DC injection to 5mA or 0.5% of rated output whichever one is greater [5] and, in the United Kingdom, ER G83/1 imposes a limit of 5mA [6].

The simplest way to eliminate DC injection is to include a grid frequency transformer. This has been the solution adopted in a number of commercial systems [7, 8]. Inclusion of a grid frequency transformer implies major disadvantages such as added cost, mass, volume and power losses. Some commercial systems include a smaller higher frequency transformer or are transformerless [8]. Measurements of DC currents from the AC output of commercial systems are presented in reference [8]. Compared to the limits imposed by AS4777.2 or by ER G83/1, the measured DC currents were found to be very significant. Methods to solve the DC injection problem have been proposed [1,9,10]. References [1] and [9] suggest the use of a feedback loop to eliminate the DC offset in the inverter output. Reference [1] suggests using a voltage sensor at the inverter output consisting of a differential amplifier and a low pass filter. Any DC detected at the output of the low pass filter is fed back to the controller which in turn operates the inverter in such a way as to reduce the DC offset. A simple mathematical model is suggested for the control system and it is assumed that the inverter is voltage controlled. However, experimental results are not reported.

Reference [9] considers a current controlled inverter. Again a sensor is connected at the output of the inverter to detect any DC offset voltage. The sensor consists of an RC circuit and a 1:1 signal transformer. It is recognised that the DC signal is of the order of less than a few mV and needs to be extracted from a total signal of more than two hundred volts which is essentially the grid supply voltage. The RC circuit is connected in series with the secondary side of the 1:1 signal transformer. The series combination is connected across the inverter output. The primary side of the 1:1 signal transformer is connected across the AC supply. Thus, if it is assumed that the signal transformer is perfect and that the secondary voltage of the transformer opposes the AC supply voltage, only DC appears across the capacitor in the RC branch. The capacitor voltage is fed back to the controller which in turn adjusts the inverter current reference so that the DC offset is eliminated. No quantitative experimental results are reported, except for a statement that the DC offset controller has been found to operate correctly. A mathematical model of the controller is presented in a subsequent paper [11]. The mathematical model is experimentally validated and it is shown that the 1:1 transformer is effective only if its primary winding time constant is sufficiently low. In other words a relatively large core and a low winding resistance are necessary, making the DC offset sensor bulky and expensive. The DC Offset controller proposed in reference [10] is based on calibration of the DC link current sensor used for controlling the inverter output current. Software ensures that current measurements made during freewheeling intervals are corrected to zero. This technique is limited to unipolar switched inverters controlled in a manner where these freewheeling intervals are easily determined.

In this paper a more cost effective DC offset sensor is proposed. Unlike references [1] and [9], where DC sensing is carried out across the AC supply terminals, the DC offset sensor is connected across the ripple filter inductors forming part of the LCL ripple filter. The disadvantage of sensing across the AC supply terminals is that the sensed DC offset could be due to sources other than the

inverter. On the other hand the DC offset detected by the proposed sensor is guaranteed to be caused by the inverter being controlled. A design procedure is developed for the proposed DC offset controller. The paper is also about investigating possible interactions between the DC offset control loop and other control loops within the system.

2. System Overview

There are a number of system configurations that have been proposed for single phase grid-connected photovoltaic (PV) systems [12]. The configuration that has been used to evaluate the DC offset elimination method is shown in figure 1. One major advantage of the chosen configuration is the use of a single-stage power electronic conversion. Power from the DC bus is converted to AC by the inverter and fed into the AC network. The DC offset controller that is being proposed represents an additional control loop for the grid-connected photovoltaic system. There are three other control loops which are described below.

2.1 Inverter Switching

The main components of the inverter are shown in figure 2. As unity power factor is aimed for reference current i_{ref} for the hysteretic current controller [12, 13] is arranged to be in phase with AC supply voltage v_s . During the positive half cycle of the source voltage, insulated gate bipolar transistor T_{B+} is kept off and T_{B-} is kept on. Transistor T_{A+} is switched on when the inverter output current (i) goes below the bottom limit of the hysteretic band. This causes i to rise while it flows through T_{A+} and T_{B-} . When current i goes above the upper limit of the band T_{A+} is switched off. This causes i to fall while it flows through D_{A-} and T_{B-} .

During the negative half cycle of the ac supply voltage, transistor T_{B-} is kept off and T_{B+} is kept on. Transistor T_{A-} is switched on when the inverter output current i goes above the top limit of the hysteretic band. This causes current i to rise negatively while it flows through T_{B+} and T_{A-} . When current i goes outside the lower limit of the band T_{A-} is switched off. This causes i to fall towards zero while it flows through D_{A+} and T_{B+} . Typical inverter output current waveforms, unfiltered (i) and filtered (i_s) are given in figure 3.

2.2 DC Bus Voltage Control

Since there is no substantial storage between the output of the solar panels and the output of the inverter, there is a need for control of power. As the insolation level rises or falls, the rms value of reference current i_{ref} should automatically rise or fall in proportion so that power balance is preserved. It is the role of the voltage control loop to maintain balance between the DC output of the PV array and the inverter output into the AC network.

As shown in figure 2, the DC bus voltage signal $k_c v_c$ and the reference voltage $k_c v_{ref}$ are inputs to the voltage controller. At steady state, if the controller uses integral action, the DC bus voltage signal $k_c v_c$ will be equal to the DC bus reference voltage $k_c v_{ref}$ and the controller output v_{ce} will be a constant. The output of the voltage controller is multiplied with the mains AC voltage signal $k_s v_s$ to produce the current reference signal $k_h i_{ref}$. The inverter output current signal $k_h i_s$ and the current reference signal $k_h i_{ref}$ are inputs to the hysteretic current controller which generates gate signals to switch appropriate inverter devices as described in section 2.1.

A rise in output power from the solar panels tends to cause a rise in DC bus voltage v_c which in turn causes a rise in v_{ce} . This causes I_{ref} (rms of i_{ref}) to rise resulting in inverter output current I_s (rms of i_s) rising because it tracks I_{ref} . The rise in current I_s restores power balance between the DC power output of the solar panels and the AC power output of the inverter. Thus the aim of the voltage control loop is to maintain power balance by getting the DC bus voltage signal $k_c v_c$ to be equal to the reference voltage $k_c v_{ref}$.

2.3 Maximum Power Tracker

The commonly used perturb and observe method [14] was selected for maximum power point tracking. The maximum power tracker is a control loop in its own right. Whereas the voltage control loop aims for balance between power output from the panels and power output by the inverter, the maximum power tracker aims to operate the solar panels at a voltage level that allows maximum extraction of power. The maximum power tracking routine was digitally implemented as follows:

- a) Calculate and record panel output power ($v_c i_p$ in figure 2);
- b) Decrement the voltage reference by Δv , where Δv is a small value;
- c) Wait a short time, about 2 to 3 seconds, to allow v_c to settle to its new value;
- d) Calculate ΔP , the change in panel output power compared to the value obtained in step(a)
- e) Reverse the previous change in reference voltage if $\Delta P \leq 0$ otherwise change the voltage reference by Δv in the same direction as the previous change.
- f) Repeat steps (a) to (e).

2.4 DC Offset Controller

The DC offset sensor is made up of a double stage RC filter. The voltage across the ripple filter inductors (v_f) is sensed and filtered. The DC offset sensor relies on the finite value of resistance of the ripple filter inductors L and L_r . If the DC component in the inverter current was constant, the DC output voltage of the sensor would be equal to IR , where I is the DC component of current and R is the resistance of the two series connected inductors. This voltage, labelled as v_o in figures 2 and 4, is earth referenced and contains a relatively low level of AC due to the action of the double stage RC filter. As shown in figure 4, the output of the filter is fed to a PI controller whose reference input is equal to zero. The output of this controller adds to the signal from the DC bus controller in such a way as to cause V_o , which is the mean value of v_o , to come down to zero. The integral action of the DC offset controller ensures that V_o is equal to zero at steady state.

The DC offset controller needs to be carefully designed. The main requirements are that:

- (a) it should not interfere with the operation of the other control loops and vice-versa;
- (b) its dynamic response must be acceptable.

3. MATHEMATICAL MODEL

Refer to figure 4 which is a block diagram representation of the DC offset sensor. The input to the DC offset sensor is the voltage across the ripple filter inductors. This voltage is assumed to be made up of two components. They are a fast changing component labelled as v_L and a slow changing component equal to $(i_o - i_c)R$. The fast changing component would essentially be a mains frequency sinusoidal signal equal to $L\omega i_s$.

One part of the slow changing component is due to an unwanted DC offset current(i_o) which may be present because of circuit imperfections. The other part is due to the compensating current i_c which is proportional to the output signal from the DC offset control loop. The reasonable assumption made in figure 4 is that the slow changing component of inverter current contributes only a resistive voltage to the input of the DC offset sensor. Similarly it is assumed that the fast changing component of the inverter current contributes only an inductive voltage to the input of the DC offset sensor. If i_o is constant at steady state, the PI controller ensures that i_c is equal to i_o thus ensuring the inverter output current is free of DC.

Referring to figure 2, for the second stage of the two-stage RC filter we have:

$$\tau_f \frac{dv_o}{dt} + v_o = v_1 \quad (1)$$

where $\tau_f = R_f C$

Since node N in figure 2 is the neutral and an MEN(multiple earthed neutral) is assumed, the current input into the first stage of the two-stage RC filter is given by:

$$\frac{V_f - V_1}{R_f} = C \frac{dV_o}{dt} + C \frac{dV_1}{dt} \quad (2)$$

which may be written as

$$\tau_f \frac{dV_o}{dt} + \tau_f \frac{dV_1}{dt} + v_1 = v_f \quad (3)$$

where $\tau_f = R_f C$

In figure 4, voltage v_o is the input to the PI controller. The relationship between v_o and the output of the integral element is given by:

$$\tau_i \frac{dv_i}{dt} + k_p v_o = 0 \quad (4)$$

where τ_i = PI controller integration time constant and k_p = proportional gain

The output of the PI controller ($k_h i_c$) is given by:

$$k_h i_c = k_p v_o + v_i \quad (5)$$

From figure 4:

$$v_f = v_L + (i_o - i_c)R \quad (6)$$

Combining equations 1 to 6 and taking the Laplace transform results in equation 7. The constant k in equation 7 is equal to $R k_p / k_h$.

$$\begin{pmatrix} (s\tau_f + 1) & (s\tau_f + k) & k/k_p \\ -1 & (s\tau_f + 1) & 0 \\ 0 & k_p & s\tau_i \end{pmatrix} \begin{pmatrix} V_1 \\ V_0 \\ V_i \end{pmatrix} = \begin{pmatrix} V_L + I_0 R \\ 0 \\ \tau_i V_i(0) \end{pmatrix} \quad (7)$$

In arriving at equation (7) coupling between the DC offset control loop and the other three control loops have been ignored. This assumption of negligible coupling needs to be justified. Any interaction between the maximum power tracker and the DC offset control loop would be through the DC bulk storage capacitor voltage v_c which is controlled by the DC bus voltage control loop. It can be argued that there is practically zero coupling between the DC bus voltage control loop and the DC offset control loop. The fundamental reason behind this is that the DC bus voltage control loop is driven by the imbalance between DC power from the DC bus and AC power injected into the AC network whereas the action of the DC offset controller has practically no effect on that power balance. That is, except for resistive losses, there is no active power associated with the injection of a DC offset current into the AC network. The resistive losses are, in practice, very small. The reduction or elimination of DC offset current in i_s will therefore cause only minor reactions from the DC bus voltage control loop which will result in very slight changes in reference current i_{ref} .

It can also be argued that the action of the DC bus voltage control loop has negligible effect on the DC offset control loop. It should be apparent from the block diagram in figure 2 that the DC bus voltage controller effectively modulates a mains frequency sinusoidal signal to produce the current reference signal $k_h i_{ref}$. The hysteretic current controller acts relatively fast and may be regarded as a pure gain. In practice the modulation rate is small compared to mains frequency. This means that the actions of the DC bus voltage controller do not result in any DC or low frequency current signals at the output of the inverter. Hence the DC bus voltage controller does not have any effect on the DC offset controller, since the latter reacts only to low frequency or DC components in the inverter output current.

The innermost loop of the inverter control system is the hysteretic current controller. As mentioned above, to the other loops the current control loop effectively appears as an amplifier with a pure gain. But the value of this gain is dependent on the magnitude of the mains voltage. Changes in the mains voltage magnitude may be regarded as disturbances in the current control loop. Slow changes in the AC voltage magnitude results in modulation of the mains frequency input signal v_o to the DC offset controller and has no effect on it. The value of the mains voltage magnitude may change suddenly by a few percent as a result of planned or unplanned disturbances on the AC network. The effect of such changes on the DC offset sensor may be assessed by treating them as mains frequency signals that appear suddenly as a disturbance and that are represented by v_L as shown in figure 4.

4. DC OFFSET CONTROLLER DESIGN

The designer of the DC offset sensor has to choose values for τ_f , τ_i and k_p to meet design specifications. It is assumed that the choice of values for R and k_h is based on criteria other than specifications for the DC offset controller. This is definitely true for the Hall Effect constant k_h which is chosen to maximize current sensor sensitivity. Resistance R could be just the inherent series resistance of the ripple filter inductors. However if it is found that the inherent resistance is too small for proper operation of the DC offset control loop, additional resistance may be added but at the expense of increased power losses.

The two main criteria specified for the DC offset controller were:

- (a) a maximum value of the mains frequency component in its output signal, and
- (b) a sufficiently damped output response.

These two design criteria are now considered in detail.

4.1 Steady State Response

The first criterion is essentially about the steady state response of the controller output signal $k_h I_c$ to the mains frequency disturbance input v_L . Equation 8, derived from equation 7 by using Cramer's rule, is a transfer function describing the response.

$$k_h I_c = \frac{-k_p [\tau_i s + 1] V_L}{\tau_i \tau_f^2 s^3 + 3 \tau_i \tau_f s^2 + (k + 1) \tau_i s + k} \quad (8)$$

The steady state response is obtained from equation (8) by setting $s = 2\pi f j$.

At 50Hz we have :

$$k_h I_c \approx \frac{-k_p V_L}{(100 \pi)^2 \tau_f^2} \quad (9)$$

Equation 9 was used to deduce τ_f . The PI controller gain k_p was chosen to be 0.4. The power frequency voltage across the filter inductor (V_L) was taken to be 25V, which corresponds to the inductors carrying rated inverter output current. A value of 10mV was used for $k_h I_c$. This was considered reasonable since, given that the Hall Effect sensor constant k_h is equal to 1.25V/A, the 10mV contributes an equivalent of 8mA of 50Hz to the multiplier that produces the current controller reference. That 50Hz signal has to be limited since its modulation by the multiplier produces a DC and 100Hz component in the inverter current reference (i_{ref}). Based on the above, equation 9 returned a value of 0.10 seconds for τ_f .

4.2 Transient Response and Stability

The output signal of the DC offset control loop, in general, is made up of a transient part and a steady state part. The steady state part is essentially made up of a mains frequency component as detailed in section 4.1 and a DC component equal and opposite to the unwanted DC offset current I_o as shown in figure 4. The transient part of controller's output is in response to sudden disturbances. These disturbances, as stated before, may be due to either planned or unplanned events. Examples of planned events that may result in sudden disturbances are system turn-on and switching operations in the AC network such as on-load tap changing giving rise to relatively sudden changes in the AC supply voltage. There are three disturbance input signals that appear explicitly in the proposed model as described by equation 7. These are integrator initial condition $v_i(o)$, unwanted DC offset i_o and sensor ac voltage input v_L . Each one of these may result in a transient response.

Unless special measures are implemented at the instant of energisation of the inverter, the integral component of the DC offset PI controller may be non-zero. If that is the case there will be a transient component in the controller's output which is given by equation 10.

$$k_h I_c = \frac{-k[\tau_f^2 s^2 + 3\tau_f s + (k+1)]v_i(0)}{\tau_i \tau_f^2 s^3 + 3\tau_i \tau_f s^2 + (k+1)\tau_i s + k} \quad (10)$$

The proposed DC offset controller may be implemented digitally or by means of an analogue controller. If it is implemented digitally it is easy to ensure that $v_i(0)$ is equal to zero at the instant of inverter energisation.

Current i_o , if it is present at the instant of inverter energisation, will also cause a transient component in the compensating current i_c . Equation 11 allows this component to be determined.

$$k_h I_c = \frac{-k_p[\tau_i s + 1](R \frac{I_0}{s})}{\tau_i \tau_f^2 s^3 + 3\tau_i \tau_f s^2 + (k+1)\tau_i s + k} \quad (11)$$

The response to sudden changes, in v_L , as would occur if there was a change in supply voltage v_s , can be determined using:

$$k_h I_c = \frac{-k_p[\tau_i s + 1]V_L(s)}{\tau_i \tau_f^2 s^3 + 3\tau_i \tau_f s^2 + (k+1)\tau_i s + k} \quad (12)$$

A necessary condition for acceptable operation of the DC offset control loop is its stability. Stability assessment can be carried out by applying the Hurwitz criterion to the system's characteristic equation which is the denominator of equations 10, 11 and 12. Inequality 13 must be satisfied to guarantee stability.

$$\tau_i > \frac{\tau_f k}{3(k+1)} \quad (13)$$

To ensure sufficient damping, integration time τ_i must be sufficiently greater than the right hand side of inequality 13. Values of all the DC offset controller design parameters are given in Table 1. The table shows how those values relate to design equations 9 and 13.

5 Test Results

To verify the proposed design of the DC offset controller, the predictions of equations 10, 11 and 13 were compared with test results. Using the chosen value for τ_i of 0.1s and the estimated value of 0.07 for k , equation 13 predicts marginal stability of the DC offset control loop when τ_i is equal to 23ms . With all controller parameters held constant and τ_i varied, the measured value of τ_i at the onset of instability was found to be 20ms. A design value of 100ms was chosen to avoid instability. A higher value would improve stability but would result in sluggish responses.

Figure 5 shows a measured transient response. The inverter was first left to run with the DC offset controller not operating. This was done by grounding the output to the DC offset controller. The controller was then activated by removing the short. The transient response of the integrator capacitor consists of the voltage changing from its initial value to the steady-state value required for elimination of any DC offset. Prediction of the controller response, which was carried out using equations (10) and (11), is shown in figure 6. There is in reasonable agreement between the predicted response and the measured response shown in figure 5. Transients such as the one shown in figure 6 are easily avoided if a digital version of the DC offset controller is used.

Figures 7 and 8 and table 2 provide additional experimental results. Figure 7 is a comparison of the DC offset sensor output waveform (v_o) with and without the DC offset controller in operation. The 50 Hz component in v_o is quite prominent compared to the DC content. Figure 8 illustrates the absence of interaction between the DC bus voltage control loop and the DC offset control loop. The

DC offset control loop is opened by forcing the controller output to zero at time t_1 . The loop is closed again at time t_2 . As shown in figure 8, the DC offset current signal, which has been extracted from the output of the DC offset sensor by additional filtering, responds accordingly. It increases as a result of the DC offset loop being opened and returns to zero after a transient period upon closure of the loop. Clearly, the DC bus voltage, also shown in figure 8, is unaffected by operation of the DC offset control loop.

It was found that without a DC offset control loop the level of DC offset current was a function of inverter output. As shown in table 2, the DC offset controller operates to ensure that the DC offset current remains within acceptable limits irrespective of the level of inverter output current.

6. Conclusions

A simple feedback system has been proposed to practically eliminate any DC offset from the output of a single phase transformerless grid-connected inverter. It is demonstrated that design of the feedback system is greatly simplified since, from a control point of view, the DC offset control loop is decoupled from other feedback loops controlling the inverter.

DC offset is monitored by sensing the voltage across the ripple filter inductor. The DC signal is extracted by using simple two-stage RC filtering. An analogue PI controller is used which ideally results in zero steady state error. In practice a small DC offset remains, but this is well within the limits imposed by standards such as Australian Standard AS4777.2 or the United Kingdom's ER G83/1.

The analogue PI controller performs very satisfactorily and its component count and cost are very low. However, digital implementation of the controller has advantages such as ease of adjustment of controller parameters and better control of integrator initial conditions at inverter start-up.

References

- [1] K. Masoud and G. Ledwich, "Grid Connection Without Mains Transformers," *Journal of Electrical and Electronic Engineering*, vol.19 (1/2), pp31-36, 1999.
- [2] A. Ahfock and A. Hewitt , "DC Magnetisation of Transformers," *IEE Proc. in Electrical Power Applications*, vol. 153, (4),pp601-607,2006.
- [3] S. Bradley and J. Crabtree, *Effects of DC from Embedded Generation on Residual Current Devices and Single-Phase Metering*, EA Technology, report No. WS4-P11, 2005.
- [4] V. Salas, E. Olias. M. Alonso and F. Chenlo, *Overview of the legislation of DC injection in the network for low voltage small grid-connected PV systems in Spain and other countries*, *Renewable and Sustainable Reviews*, vol 12, Issue 2, February 2008, pp575-583.
- [5] AS 4777.2, *Grid Connection of Energy Systems via Inverters Part 2: Inverter Requirements*, Australia, 2002.
- [6] ER G83/1, *Recommendations for the Connection of Small-Scale Embedded Generators (up to 16 A per phase) in parallel with public low-voltage distribution networks*, United Kingdom, September 2003.
- [7] H. Haeberlin, Ch. Liebi, and Ch. Beutler, *Inverters for Grid-Connected PV Systems: Test Results of Some New Inverters and Latest Reliability Data of Most Popular Inverters in Switzerland*, 14th European Photovoltaic Solar Energy Conference Barcelona (Catalunya) Spain, June/July 1997.

- [8] V. Salas, E. Olias, M. Alonso, F. Chenlo and A. Barrado, *DC Current Injection into the Network from PV Grid Inverters*, IEEE 4th World Conference on Photovoltaic Energy Conversion, May 2006, pp2371-2374.
- [9] R Sharma, *Removal of DC Offset Current from Transformerless PV Inverters Connected to Utility*, Proceedings of the 40th International Universities Power Engineering Conference, Cork Institute of Technology, Ireland, pp1230-1234, 2005.
- [10] M.Armstrong, D.J.Atkinson, C.Mark Johnson, *Auto-Calibrating DC Link Current Sensing Technique for Transformerless, Grid Connected, H-Bridge Inverter Systems*, IEEE Transactions on Power Electronics, September 2006, volume 21, N^o 5, pp1385-1393.
- [11] A. Ahfock and L. Bowtell, *DC Offset Elimination in a Transformerless Single Phase Grid-Connected Photovoltaic System*, Australasian Universities Power Engineering Conference, AUPEC 06, Victoria University, Melbourne, September 2006.
- [12] M.Calais J.Myrzik, T.Spooner and V.G.Agelidis, *Inverters for Single-Phase Grid Connected Photovoltaic Systems – an Overview*, IEEE 33rd annual Power Electronics Specialists Conference, vol 4, pp 1995-2000, 2002
- [13] C.M.Liaw, T.H.Chen, T.C.Wang, G.J.Cho, C.M.Lee and C.T.Wang, *Design and Implementation of a single phase current-forced switching mode bilateral convertor*, IEE Proceedings-B, vol 138, No. 3, pp129-136, May 1991.
- [14] G.M.S. Azevedo, M.C.Cavalcanti, K.C.Oliveira, F.A.S.Neves and Z.D.Lins, *Comparative Evaluation of Maximum Power Point Tracking Methods for Photovoltaic Systems*, American Society of Mechanical Engineering, Journal of Solar Energy, Engineering, vol. 131, pp 031006-1/8, 2009 .

Table 1 : DC Offset Controller Design Parameters

Design variable	Chosen value	Comments
Current Sensor constant (k_h)	1.25 V/A	<ul style="list-style-type: none"> • Determined by number of turns used with the Hall-Effect sensor. • Inadequate sensitivity if value too low • Maximum value limited by DC rail voltage
AC component in DC offset controller output signal (k_{hi_c})	10mV	<ul style="list-style-type: none"> • Represents the undesirable 50Hz component in the output of the DC offset sensor. • Chosen limit dictates the value of the filter time constant τ_f given by equation 9. • If chosen limit is too small, τ_f becomes too large making the filter harder to implement
Filter resistance(R_f) and Filter capacitance(C)	220kΩ 0.47uF	<ul style="list-style-type: none"> • $R_f C$ or τ_f is dictated by equation 9 • R_f cannot be made larger than a few hundred kΩ because of the effect of noise and stray impedances
Series resistance (R)	0.2Ω	<ul style="list-style-type: none"> • Can consist of just the inductors' resistance or additional series resistance may be added. • Choice of R dictated by efficiency considerations.
PI controller gain (k_p)	0.4	<ul style="list-style-type: none"> • For a given degree of stability, increasing k_p will mean increasing τ_i, making integrator implementation difficult • Too low a value of k_p leads to sluggish controller response.
PI controller Integration time (τ_i)	100ms	<ul style="list-style-type: none"> • For the chosen value of k, defined as $k_p R / k_h$, inequality 13 predicts a τ_i value of 23ms for marginal stability • A value of τ_i sufficiently higher than 23ms was chosen to ensure adequate damping.

Table 2 : DC Offset Currents

Inverter AC Output Current (A rms)	Inverter DC offset current(mA) with control loop open	Inverter DC offset current (mA) with control loop closed
1.0 A	30mA	1.02mA
2.0A	13mA	0.86mA
3.0A	-8.1mA	0.52mA
4.0A	-22mA	0.61mA

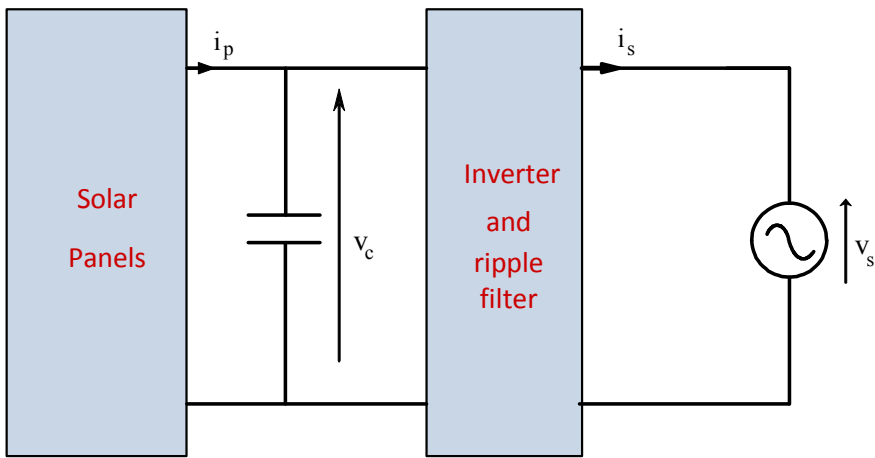
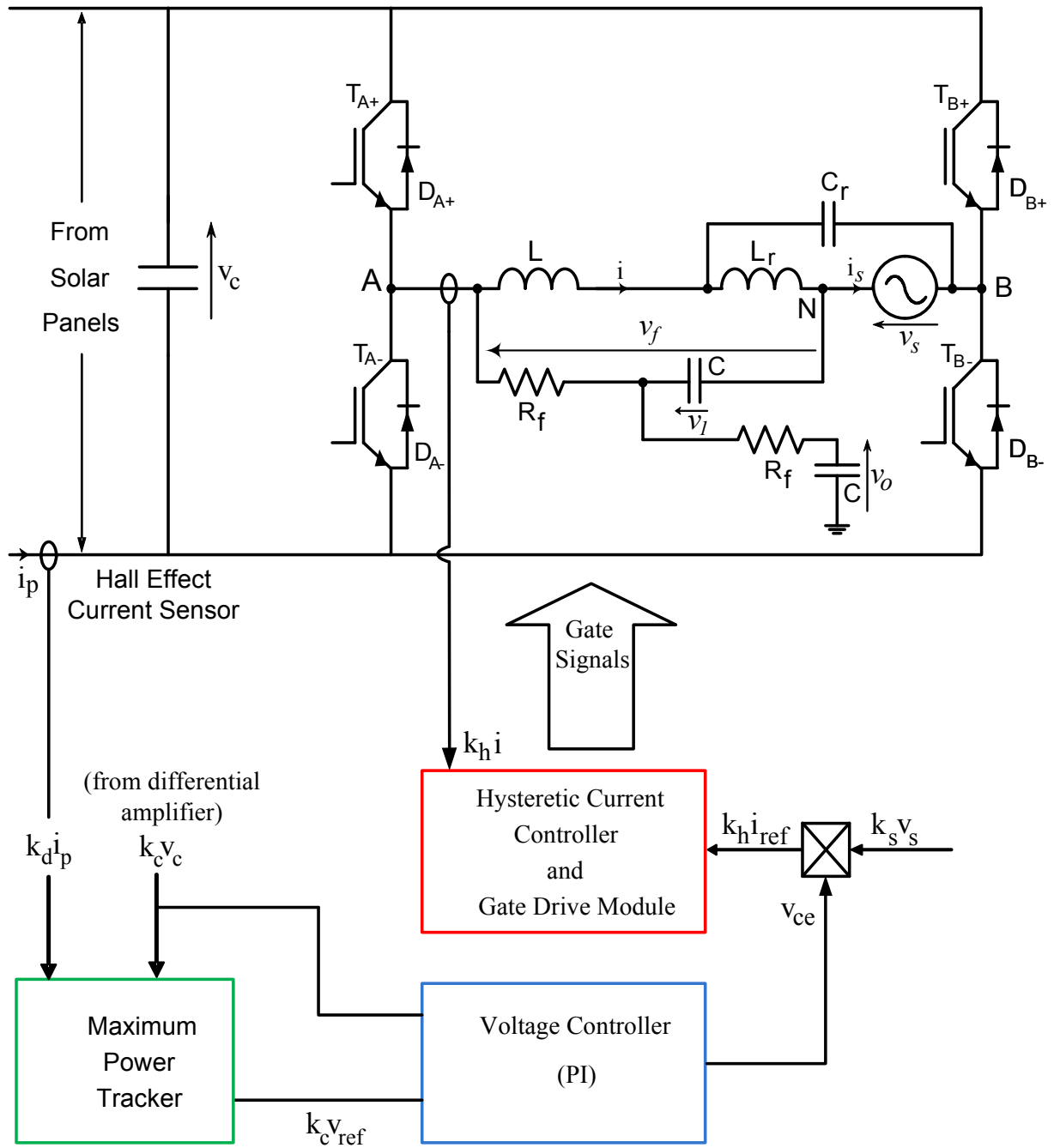

Figure 1: Grid-Connected PV System



k_c , k_d , k_h and k_s are current or voltage sensor constants

Figure 2: Inverter Main Components and DC Offset Sensor

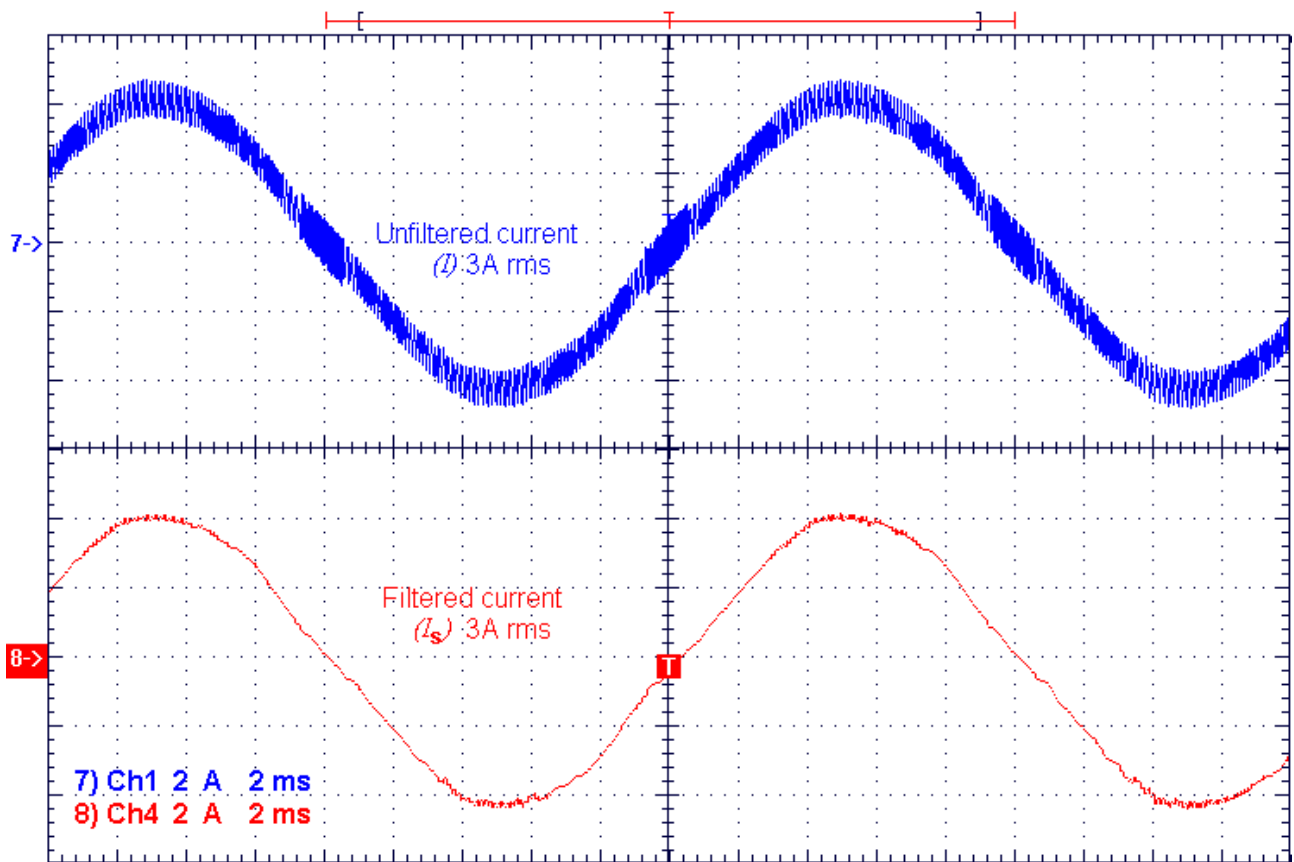

Figure 3: Inverter Output Current Waveform ($I_{ref} = 3A$)

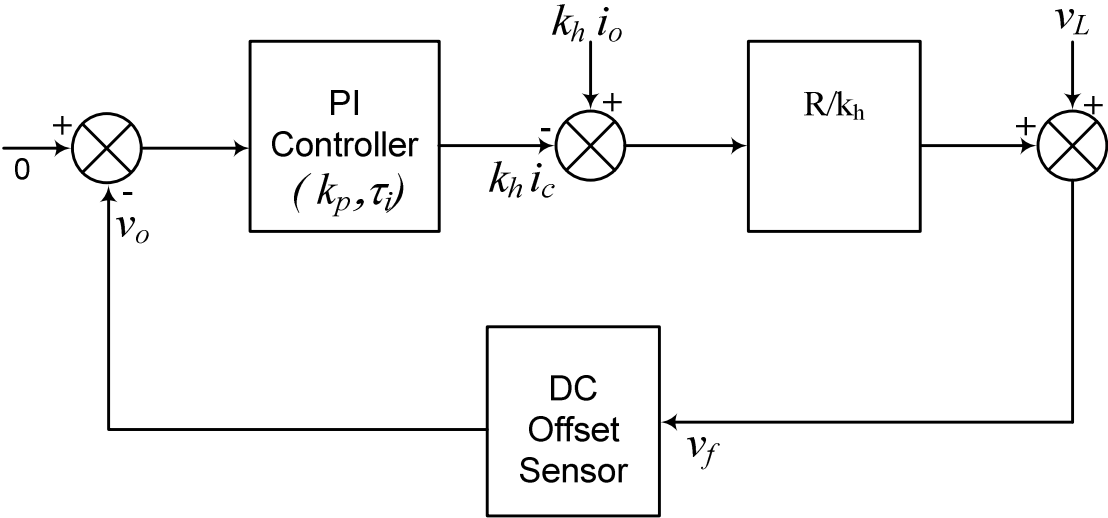

Figure 4: DC offset sensor block diagram

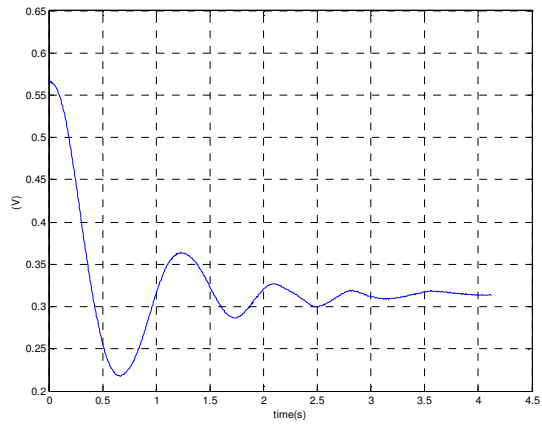

Figure 5: Measured Transient Response of PI Controller Output

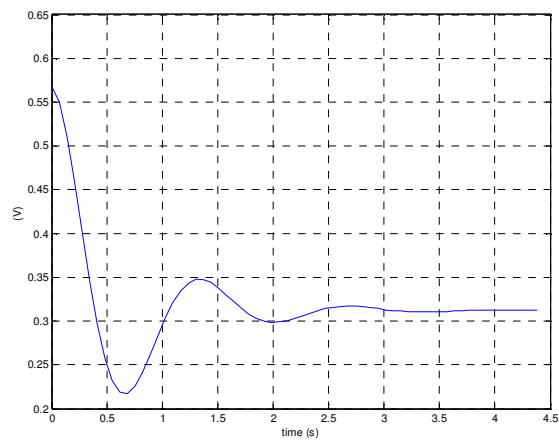

Figure 6: Simulated Transient Response of PI Controller Output

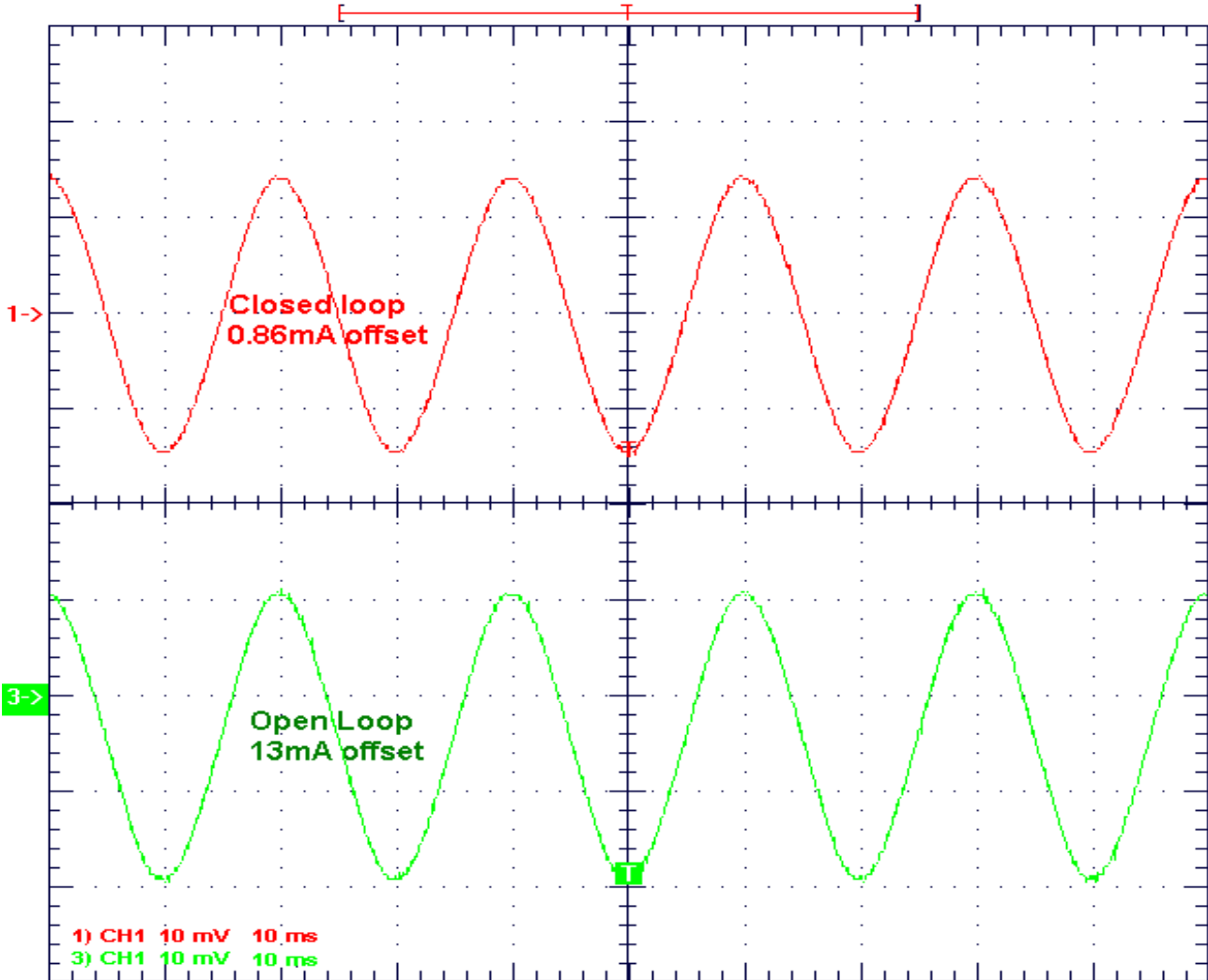

Figure7: DC Offset sensor output

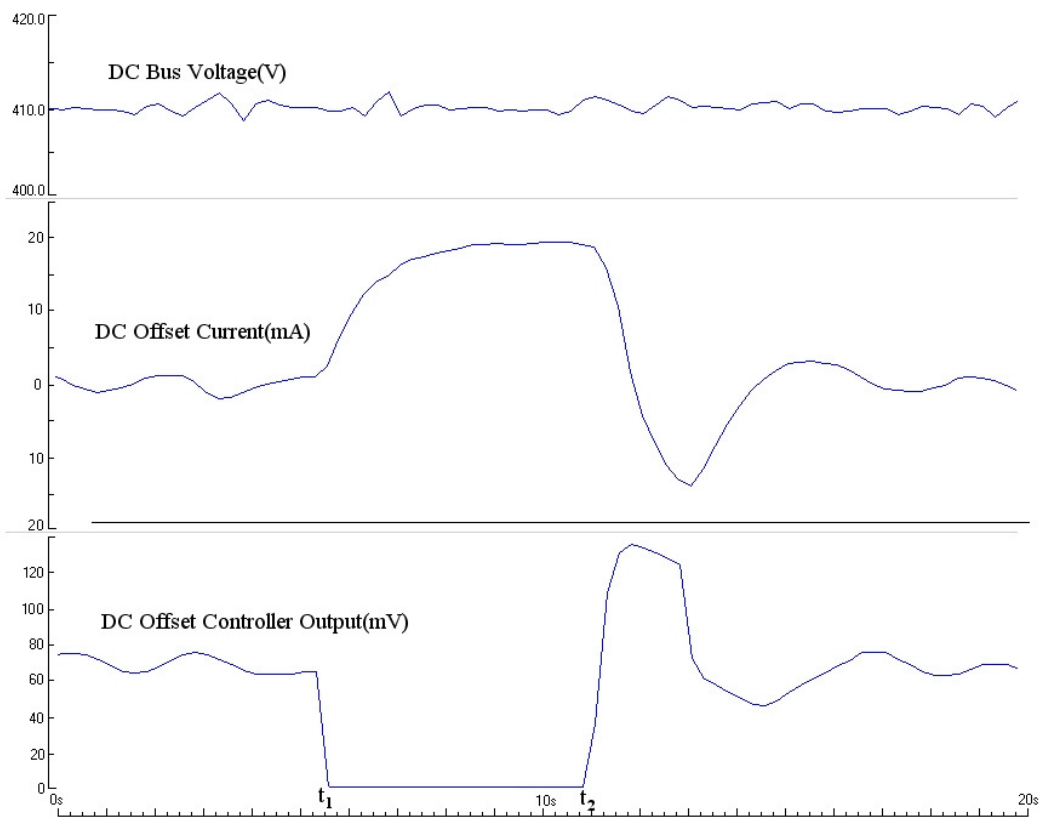

Figure 8: Interaction between the DC offset controller and the DC bus voltage controller