

**Aus der Medizinischen Poliklinik-Innenstadt  
der Ludwig-Maximilians-Universität  
München**

**Direktor: Professor Dr. med. M. Reincke**

**Immunobiology of the VPAC2 Receptor**

**Dissertation  
zum Erwerb des Doktorgrades der Medizin  
an der Medizinischen Fakultät der  
Ludwig-Maximilians-Universität zu München**

**Vorgelegt von**

**Carola Grininger  
aus  
München**

**2010**

Mit Genehmigung der Medizinischen Fakultät  
der Universität München

Berichterstatter: Prof. Dr. med. S. Schewe

Mitberichterstatter: PD Dr. B. Bachmeier

Prof. Dr. H. Kellner

Prof. Dr. U. Gresser

Betreuung durch den

promovierten Mitarbeiter: PD Dr. P. J. Nelson

Dekan: Prof. Dr. med. Dr. h.c. M. Reiser, FACR, FRCR

Tag der mündlichen Prüfung: 07.10.2010

# CONTENTS

Contents.....	3
Summary.....	5
1. Introduction.....	10
1.1 General introduction.....	10
1.2 G-Protein-coupled Receptors.....	10
1.3 G-protein-coupled signalling.....	13
1.4 Molecularbiology and structure of VPAC Receptors.....	15
1.5 Vasoactive Intestinal Peptide (VIP).....	22
1.5.1 Biochemical structure of vasoactive intestinal peptide.....	22
1.6 VIP and intracellular signaling.....	25
1.7 VIP and rheumatoid arthritis.....	26
1.8 Hypothesis.....	29
2. Materials.....	31
2.1 Bacteria .....	31
2.2 Vectors.....	31
2.3 Cells.....	32
2.4 Mice.....	33
2.5 Oligonucleotides.....	33
2.6 Enzymes.....	33
2.7 Chemicals and reagents.....	33
2.8 Antibodies.....	34
2.9 Solutions, media and buffer.....	34
2.10 Instruments.....	36
2.11 Software.....	37
3. Methods.....	38
3.1 RNA isolation from mouse tissue.....	38
3.2 DNase I digestion of RNA.....	38
3.3 First strand cDNA Synthesis for PCR.....	38
3.4 Cleaning methods of nucleic acid.....	39

3.4.1 Phenolextration.....	39
3.4.2 Ethanolprecipitation.....	39
3.5 Amplification of cDNA with PCR.....	39
3.6 Cloning of the mVPAC1 and mVPAC2 receptor.....	42
3.6.1 Plates culture and solution cultures.....	44
3.6.2 Isolation of DNA fragments from agarose gels.....	44
3.6.3 Ligation of the plasmid.....	45
3.6.4 Transformation protocol.....	45
3.6.5 Generation of stable human Jurkat T cells transfectants.....	45
3.6.6 Electroporation.....	45
3.7 Ligand competitive binding assay.....	46
3.8 cAMP ELISA assay.....	47
3.9 Transwell migration assay.....	48
3.10 Flow cytometry apoptosis assay.....	50
3.11 Statistics.....	50
4. Results.....	51
4.1 Alternative splicing of VPAC2.....	51
4.2 Stable mVPAC human Jurkat T cell transfectants.....	52
4.3 VIP Competitive Binding Assay of human Jurkat T cell transfectants....	55
4.4 cAMP assay of human Jurkat T cell transfectants.....	57
4.5 Starvation survival studies of human Jurkat T cell transfectants.....	59
4.6 Flow cytometry apoptosis study of human Jurkat T cell transfectants....	61
4.7 Migration study of human Jurkat T cell transfectants.....	63
5. Discussion.....	65
6. Literature.....	75
7. Abbreviations.....	85
8. Acknowledgements.....	88
9. Curriculum Vitae.....	89



## Summary

Rheumatoid arthritis (RA) is a debilitating autoimmune disease of unknown etiology characterized by chronic joint inflammation accompanied by cartilage and bone destruction. Standard treatment regimens include disease-modifying medications like methotrexate, hydroxychloroquin, sulfasalazine and anti-TNF- $\alpha$ -therapy (American College of Rheumatology guidelines). New treatment strategies concentrate on the use of immunomodulatory agents such as the vasoactive intestinal peptide (VIP). VIP based treatment has shown to significantly reduce the incidence and severity of arthritis in animal models, abrogating joint swelling and destruction of cartilage and bone. The effect was associated with down regulation of both the inflammatory and autoimmune components of the disease.

VIP is expressed in different primary immune organs (bone marrow and thymus) and also in the central and peripheral nervous systems. In the immune system, VIP acts as a chemotactic factor for T cells, and transduces expression of the matrix metalloproteinase MMP-9, thus facilitating T cell movement across basement membranes and other tissue structures. VIP binds with high-affinity to its two vasocative intestinal peptide receptors; VPAC1 and VPAC2.

VPAC receptors are members of the G-protein coupled receptor (GPCR) –B family that also includes the receptors for the VIP related pituitary adenylyl cyclase-activating peptide (PACAP), secretin, glucagon, and calcitonin. Ligand binding activates these GPCR receptors, which stimulates adenylate cyclase activity and induces cyclic AMP (cAMP) increase. The VAPC2 receptor gene is encoded by 13 exons, the initiator codon of the 438 amino acid open reading frame is located in the exon 1, and the termination signal and a poly-adenylation signal sequence are found in exon 13. Other receptors belonging to this family are alternatively spliced, generating isoforms of the receptor.

The central aim of this study was to identify and characterize murine VPAC2 splice variants. One splice variant, mVPAC2<sup>del-78</sup>, missing the first extracellular domain and the first transmembrane domain was identified in mouse lung tissue and further characterized. To this end, wildtype mVPAC1 and VPAC2<sup>del-78</sup> cDNAs were cloned and expressed in Jurkat T cells. <sup>125</sup>I-VIP receptor binding affinity was lower in mVPAC2<sup>del-78</sup>

compared to wildtype mVPAC1 transfectants. However, both mVPAC1 and mVPAC2<sup>del\_78</sup> transfectants showed an increase in intracellular cAMP concentration upon VIP or PACAP ligand binding, but mVPAC2<sup>del\_78</sup> was effective less than mVPAC1 transfectants. MVPAC2<sup>del\_78</sup> transfectant survival was serum dependent, whereas wildtype mVPAC1 transfectants tolerated serum starvation. Interestingly, mVPAC2<sup>del\_78</sup> transfectants showed less apoptosis compared to mVPAC1 and control pIRES transfectants. Both mVPAC1 and mVPAC2<sup>del\_78</sup> transfectants showed reduced migration rates compared to control transfectants upon VIP treatment. This phenomenon was overridden by stromal derived factor-1 (SDF-1) treatment in mVPAC1 transfectants but not in mVPAC2<sup>del\_78</sup> transfectants.

### **Conclusions:**

A new VPAC2 deletion variant was successfully isolated from mouse lung tissue. This deletion variant was examined regarding binding, apoptosis-signaling and migration. There were minor differences regarding binding to VIP between the VPAC transfectants, which so not appear to explain the different cAMP rise after stimulation. However, studies showed less apoptosis in mVPAC2 deletions variant as compared to mVPAC1 transfectants. Migration studies showed no differences regarding the general migration of the VPAC transfectants; they both were effectively inhibited by VIP.

More studies are necessary to examine the impact of these receptors during treatment of autoimmune diseases with VIP.

## **Zusammenfassung**

Die rheumatoide Arthritis ist eine Autoimmunerkrankung unklarer Ursache charakterisiert durch chronische, polyartikuläre Gelenkentzündungen begleitet in ca. 50% der Fälle von Knorpel- und Knochenzerstörung. Behandelt wird diese Erkrankung gemäß der Richtlinien 2008 des American College of Rheumatology mit erkrankungsmodifizierenden Antirheumamedikamenten wie Methotrexat, Hydroxychloroquin, Sulfasazalin und TNF- $\alpha$ -Blockern. Eine neue Therapiestrategie konzentriert sich auf die Verwendung von vasoaktivem intestinalem Peptid (VIP). Die Behandlung mit VIP reduzierte signifikant das Auftreten und den Schweregrad der Arthritis im Tiermodell und verhindert die Zerstörung von Knorpel und Knochen. Der Effekt war assoziiert mit der Runterregulierung der Entzündung und von Komponenten der Autoimmunität bei der Erkrankung.

VIP ist ein chemotaktischer Stimulus für T- Zellen, einerseits modifiziert die Expression von Matrixmetalloproteinasen (MMP-9), andererseits erleichtert es die Migration der T-Zellen durch die Basalmembran und andere Gewebe. Vasoaktives intestinales peptide (VIP) and pituitary adenylate cyclase-aktivierendes Polypeptid (PACAP) sind bedeutende intrazelluläre Botenstoffe sowohl im zentralen als auch im peripheren Nervensystem und darüber hinaus in einer Vielfalt von nicht neuronalen Geweben. VIP ist ein wirksamer Neurotransmitter mit verschiedenen physiologischen Funktionen, der in vielen Geweben exprimiert wird, primäre Immunorgane eingeschlossen. VIP bindet mit hoher Affinität an VPAC1- und VPAC2-Rezeptoren während das zugehörige pituitary adenylate cyclase-aktivierendes Polypeptide (PACAP) mit geringerer Affinität an die gleichen Rezeptoren und mit hoher Affinität an den PAC1 Rezeptor bindet. Diese Rezeptoren sind Mitglieder der G-Protein gekoppelten Rezeptoren (GPCR-) -B Familie, welche auch die Rezeptoren für PACAP, Secretin, Glucagon und Calcitonin beinhaltet. Die Adenylatcyclase Aktivität wird durch die Rezeptoren der GPCR-B Familie stimuliert mit einem konsekutiven Anstieg des zyklischen AMP (Adenosine monophosphat). Das VPAC2 Rezeptorgen ist auf dem Exon 13 kodiert, das Initiatorcodon des 438 Aminosäuren offenen Leserahmen ist auf Exon 1 lokalisiert, das Beendigungssignal und die Polyadenylationssignal Sequenz ist lokalisiert auf Exon 13. Andere zu dieser Familie



gehörende Rezeptoren sind alternativ gespleißt um verschiedene Isoformen zu bilden. Es ist bis dato noch keine Isoform des VPAC2 Rezeptors in der Literatur beschrieben.

Das Ziel dieser Studie war es, die Biologie des VPAC2 Rezeptors zu verstehen und eine gefundene Deletionsvariante des VPAC2 Rezeptors (mVPAC2<sup>del\_78</sup>) der Maus zu beschreiben.

**Methoden:** Der Maus-Deletionsvariante mVPAC2<sup>del\_78</sup> identifiziert aus dem Mauslungengewebe fehlen die Aminosäuren 115-138; die Variante erstreckt sich von der ersten extrazellulären Domäne bis zum ersten Teil der Transmembranendomäne. Die vorliegende Arbeit etabliert die Existenz dieser neuen Splicevariante (26 Aminosäuren fehlend) und beschreibt ihre funktionellen Eigenschaften im Hinblick auf Bindung, Aktivität der Adenylate cyclase (erhöhtes cAMP), Apoptose und Migration. Um diese Splicevariante weiter zu untersuchen, klonierten wir den Wildtyp des VPAC1-Rezeptors, die Deletionsvariante des VPAC2-Rezeptors (mVPAC2<sup>del\_78</sup>) der Maus in vergleichbaren Konzentrationen in humane Jurkat T-Zellen und als Kontrolle den pIRES (primary internal ribosomal entry site) Vektor alleine ohne Rezeptor.

**Ergebnisse:** Maus VPAC1 transfizierte Jurkat T Zellen banden <sup>125</sup>I-markiertes VIP mit hoher Affinität. Es wurde von mVPAC2<sup>del\_78</sup> transfizierten mit geringerer Affinität gebunden und die Kontroll-transfizierten wurden gar nicht gebunden. Maus VPAC1 transfizierte und zu einem geringeren Ausmaß mVPAC2<sup>del\_78</sup> transfizierte Jurkat T Zellen zeigten eine VIP oder PACAP-38 ausgelöste Erhöhung von intrazellulärem cAMP und eine minimale Erhöhung in den Kontroll-transfizierten. In Serumentzug-Überlebensstudien (serum starvation) zeigten mVPAC2<sup>del\_78</sup> transfizierte und Kontroll-transfizierte Jurkat T Zellen eine Serumabhängigkeit, dagegen demonstrierten mVPAC1 transfizierte eine Serumunabhängigkeit. In Apoptosestudien zeigte mVPAC2<sup>del\_78</sup> geringere Apoptose als mVPAC1 und Kontroll-transfizierte Jurkat T Zellen. Migrationsstudien zeigten, dass VIP eine signifikante Reduzierung der Zellmigration in mVPAC2<sup>del\_78</sup> und mVPAC1 transfizierten Jurkat T Zellen verursachten, aber nicht in den Kontroll transfizierten. VIP Behandlung auf human stromal derived factor

vorbehandelte Zellen hemmte signifikant die Zellmigration von mVPAC1 und Kontroll transfizierten, aber nicht von mVPAC2<sup>del\_78</sup> transfizierten Jurkat T Zellen.

**Schlussfolgerung:** Es wurde eine neue VPAC2 Deletionsvariante (mVPAC2<sup>del\_78</sup>) von Maus-Lungengewebe erfolgreich isoliert. Diese mVPAC2<sup>del\_78</sup> Deletionsvariante wurde hinsichtlich ihres Bindungs-, Apoptose-Signals und Migrationsverhaltens untersucht. Bezüglich Bindung an VIP war ein kleiner Unterschied zwischen den VPAC transfizierten Zellen erkennbar, welches die Abweichungen in dem cAMP Anstieg nach Stimulierung erklären könnte. In der cAMP Signaltransduktion demonstrierte die mVPAC2<sup>del\_78</sup> Deletionsvariante einen geringen cAMP Anstieg.

Die Apoptoseuntersuchungen weisen bei mVPAC2<sup>del\_78</sup> Deletionsvariante eine geringere Apoptoserate auf als mVPAC1 transfizierte Jurkat T Zellen.

In den Migrationstudien besteht kein signifikanter Unterschied hinsichtlich des Migrationsverhalten der VPAC transfizierten Zellen, sie stellen beide ein gehemmtes Migrationsverhalten hinsichtlich VIP dar.

# **1. Introduction**

## **1.1 General introduction**

In this thesis the functional role of vasoactive intestinal peptide (VIP) receptors in transfected Jurkat T-cells was examined. VIP receptors are members of the G-protein-coupled receptors class II that use vasoactive intestinal peptide (VIP) as ligand (Segre et al., 1992). In immunity, VIP acts as a neuroimmunomodulator affecting various immune responses. The results of *in vitro* studies initially directed attention toward subsets of B cells and T cells, which express G-protein coupled receptors for VIP. The first published VIP actions were on T cells and dealt with enhanced adhesion and migration, decreased activation-induced apoptosis, altered generation of diverse cytokines and modified regulation of T cell-dependent B cell production of several immunoglobulins (Goetzl et al., 1995b).

## **1.2 G-Protein-coupled Receptors**

The function of a cell is dictated in large part by carefully regulated networks of biochemical processes. Cells use signal transfer instruments (surface receptors) to exchange information with their environment. Receptors transmit signals intracellular by activating intracellular signalling pathways. Many different classes of membrane-bound receptors exist including; ionotropic receptors, transmembrane receptors with enzyme activity, and the largest family, the G-protein coupled receptors.

G-protein-coupled receptors (GPCR`s), also known as seven transmembrane domain receptors, comprise a superfamily with more than 1000 different members identified (Kolakowski, 1994). Many different ligands exist for these receptors including; amines, lipids, peptides, nucleotides, glycoproteins, proteases and ions (Kolakowski, 1994). Historically, GPCR`s have been classified into six subfamilies which were thought to be unrelated; three of these are found in vertebrates (Kolakowski, 1994).

The three vertebrate families are the rhodopsin family (A), the secretin-receptor family (B), and the metabotropic glutamate receptor family (C).

GPCRs are thought to have a similar molecular architecture consisting of seven  $\alpha$ -helical transmembrane domains (7TM), three extracellular loops (EC1, EC2, and EC3), three intracellular loops (IC1, IC2, and IC3), an amino-terminal extracellular domain and an intracellular carboxyl terminus. GPCRs can exist in active or inactive forms, where the inactive forms are favored. Some GPCRs exhibit constitutive activity under normal circumstances as in absence of the respective activating ligands (Holst and Schwartz, 2003; Parnot et al., 2002). The study of chimeric and mutated GPCRs have demonstrated that the second (IC2) and third intracellular (IC3) loops, and to a lesser extent the proximal part of the carboxyl terminal tail, can be directly involved in G-protein/receptor interactions (Wess, 1997).

extracellular

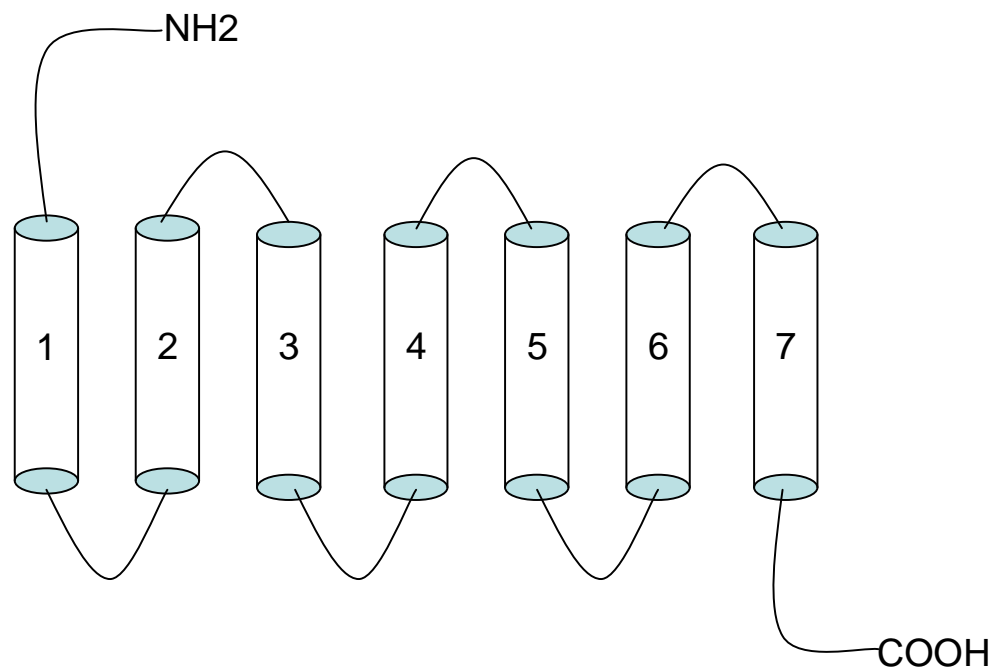

**Figure 1: G-Protein-coupled Receptor**

Upon ligand activation, GPCR's associate with distinct classes of heterotrimeric G proteins composed of three subunits, the  $\alpha$ -subunit that has the guanine-nucleotide binding site and GTPase activity, and the  $\beta$ - and  $\gamma$ -subunits that form tightly bound dimer. The subunits of G proteins show a wide range of heterogeneity. There are more than 20 different mammalian  $G\alpha$  subunits and 5  $\beta$  and 14  $\gamma$  subtypes known, which are found in nature in many possible combinations (Radhika and Dhanasekaran, 2001).

Stimulation of the G proteins subfamily activates adenylyl cyclase, whereas stimulation of the  $G_i$  subfamily leads to the inhibition of the adenylyl cyclase and activates  $K^+$  channels. Stimulation of the  $G_q$  subfamily activates phospholipase C (PLC), and the  $G_{12}$  family is implicated in the regulation of small GTP binding proteins.

Within the superfamily of G protein-coupled receptors, there has emerged during the past few years a subfamily that shares the seven membrane-spanning domain topography, but has a low overall amino acid sequence homology (<20%) with other members of the superfamily. It is now referred to as the class II G protein-coupled receptor family and comprises receptors for a structural family of peptides that includes VIP, PACAP, glucagon, secretin, glucagon-like peptide 1, gastric inhibitory polypeptide, growth hormone-releasing factor and receptors for parathyroid hormone and calcitonin (Nicole et al., 1998).

In many cases, these G proteins can couple to more than one receptor subtype, with different affinities.

Family	Some member	Action mediated	Functions
I	$G_s$	$\alpha$	Activate adenylyl cyclase, $Ca^{2+}$ channels
	$G_{olf}$	$\alpha$	Activate adenylyl cyclase in olfactory sensory neurons
II	$G_i$	$\alpha$	Inhibit adenylyl cyclase
		$\beta\gamma$	Activate $K^+$ channel
	$G_o$	$\beta\gamma$	Activates $K^+$ channel, inactivate $Ca^{2+}$ channel
		$\alpha$ and $\beta\gamma$	Activates phospholipase C- $\beta$
	$G_t$ (transducin)	$\alpha$	Activates cyclic GMP phosphodiesterase in vertebrate photoreceptors
III	$G_q$	$\alpha$	Activates phospholipase C- $\beta$
IV	$G_{12}$	$\alpha$	Activates Rho guanine-nucleotide exchange factors (GEFs)

**Table 1: The four major families of G-protein (adapted from [isoft.postech.ac.kr/.../content/intro.html](http://isoft.postech.ac.kr/.../content/intro.html))**

### 1.3 G-protein-coupled signalling

G-protein-coupled receptors are expressed on the cell surface and transmit extracellular cell signals by acting as ligand-activated guanine nucleotide exchange factors (GEFs) for the heterotrimeric G proteins to intracellular second messenger systems.

All GPCR`s share a common signalling mechanism in that they interact with G proteins (heterotrimeric GTPases) to regulate the synthesis of intracellular second messengers such as cyclic AMP, inositol phosphates, diacylglycerol and calcium ions (Harmar, 2001). Additional signalling pathways acting through protein kinases dependent on stimulation of some of the GPCR`s can also be activated, which demonstrates an additional level of complexity in their signal mechanisms (Knall and Johnson, 1998).

Several authors have shown that posttranslational modifications at GPCR's including phosphorylation, glycosylation and enzymatic influence can play a role in the regulation of G-protein coupled signal transduction (Foord and Marshall, 1999; Pitcher et al., 1998). Importantly, the modulation of transmembrane signalling by G protein-coupled receptors constitutes the single most important set of therapeutic targets in medicine. Nearly 40% of all current therapeutics target GPCR's (Brink et al., 2004).

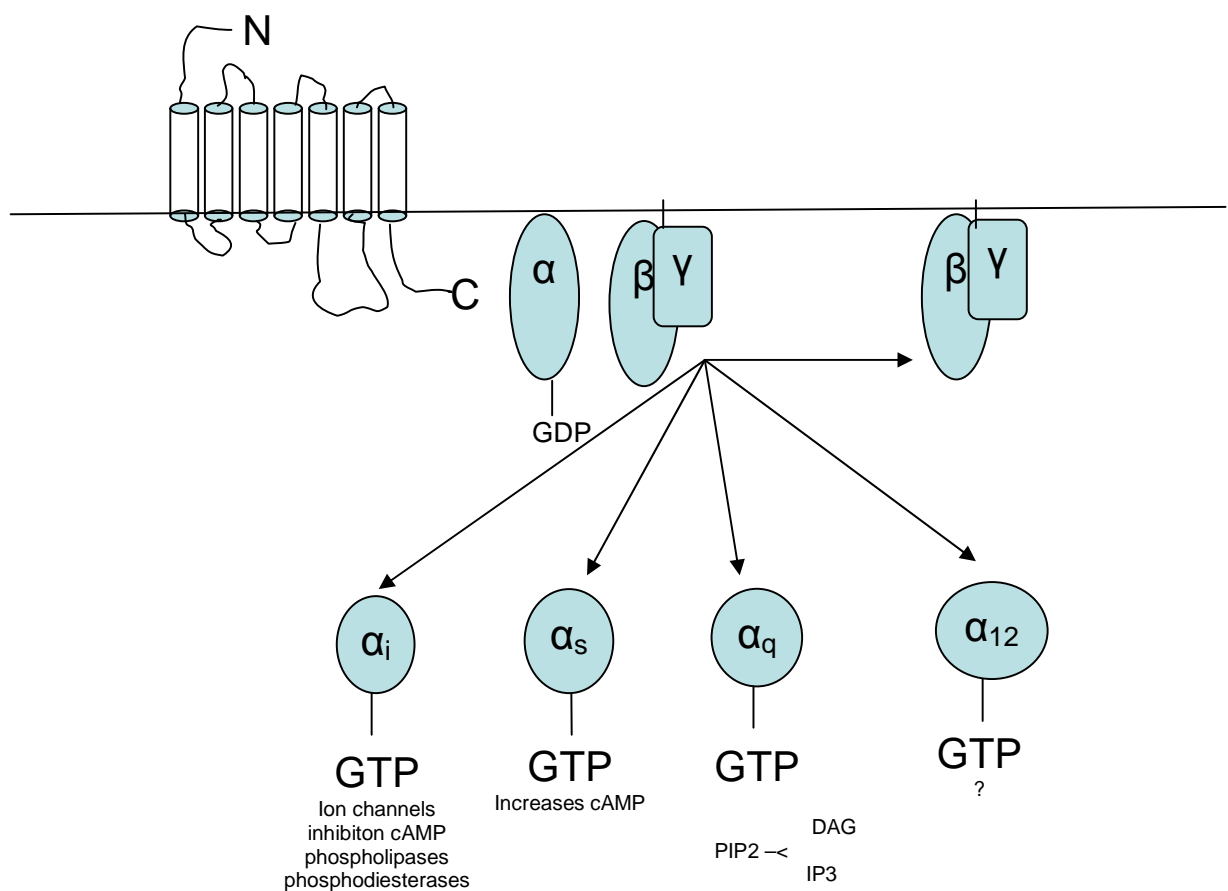

**Figure 2: Diversity of the G protein-coupled receptor signalling transduction system (adapted from Gutkind) (Gutkind, 1998)**

### G protein coupled receptor biological functions

- Smell and taste
- Perception of light
- Neurotransmission
- Function of endocrine and exocrine glands
- Chemotaxis
- Exocytosis
- Control of blood pressure
- Embryogenesis
- Development
- Cell growth differentiation
- HIV infection
- Oncogenesis

### **1.4 Molecular biology and structure of VPAC Receptors**

There exist two classes of receptors for VIP; VPAC1R and VPAC2R which display different affinities and specificities (Fahrenkrug, 1993). VPAC1R and VPAC2R are GPCRs with adenylate cyclase activity, which VIP shares with pituitary adenylate cyclase-activating polypeptide (PACAP), another neuropeptide (Severi et al., 2006). These receptors comprise one polypeptide chain with seven transmembrane segments, one N-terminal extracellular end and one C-terminal cytoplasmic end (Laburthe et al., 1994). The VPAC receptors are distributed in a variety of organs and systems in the human body which suggests a potential global role in diverse biological processes. This thesis is focused on their potential role in cells of the immune system.

The VPAC1 receptor was first isolated from a rat lung cDNA library by cross-hybridization with a secretin receptor (Ishihara et al., 1992). The human VPAC1 cDNA was first isolated from HT29 human colonic adenocarcinoma cell line library (Goetzl et al., 1995b) and is located on short arm of human chromosome 3 (3p22) (Sreedharan et



al., 1995). The VPAC1R receptor consists of 457 amino acids with a long extracellular N-terminal and with a calculated Mw of 52 kDa. The gene is composed of 13 exons ranging in size from 42 to 1400 bp (Goetzl et al., 1995b). VPAC1 shows strong evolutionary conservation.

Using reverse transcription-polymerase chain reaction (RT-PCR) analysis, it was previously demonstrated that VIP receptor 1 (VPACR1) is constitutively expressed in intraepithelial and lamina propria T lymphocytes from both small and large intestine. The VPAC1 receptor is also expressed in different areas of the human body including lung, kidney, intestinal tract and some areas in the brain (Ishihara et al., 1992).

This receptor corresponds to the PACAP-II receptor and displays same affinity towards VIP and PACAP.

VPAC2R was first cloned from a rat olfactory bulb cDNA library by Lutz and subsequently from a human placenta cDNA library (Lutz et al., 1993). VPAC2R was later characterized as a receptor for VIP and PACAP showing a similar response to both ligands.

The human VPAC2 receptor gene is located on chromosome 7q36.3 (Mackay et al., 1996). Lutz described the characterization of VPAC2 gene structure and promoter region. The VPAC2 receptor is encoded by 13 exons with intron sizes ranging from 68 bp (intron 11) to 45 kb (intron 4) (Lutz et al., 1999). The VPAC2R receptor consists of 438 amino acids and with a calculated Mw of 49 kDa.

VPAC2R is expressed more selectively than VPAC1R. The VPAC2 receptor is expressed mainly in the CNS (thalamus & suprachiasmatic nucleus), but can also be detected in other tissues like the pancreatic B-islet cells, stomach, colon, lung, heart, kidney and immune system (Adamou et al., 1995; Cagampang et al., 1998; Ishihara et al., 1992; Usdin et al., 1994). Harmar examined the distribution of the VPAC2 receptor in mouse tissue (Harmar et al., 2004). VPAC2R was most abundantly found in the murine lung and gastrointestinal tract tissue. In contrast to VPAC1R, VPACR2 was identified only in T cells from small intestine (Qian et al., 2001). VPAC2R is found at very low levels on resting monocytes and T cells, but its expression increases after activation of these cells (Lara-Marquez et al., 2001).

Two selective agonists for the VPAC1 receptor have been described: VIP (1-7) GRF (8-27)-NH<sub>2</sub> (VIP/GRF hybrid) and chicken secretin. The VPAC1 receptor antagonist Acetyl-His1 [Dphe2,K15,R16,L27] is highly selective for VPAC1 receptor (Gourlet et al., 1997). There are two VPAC2 receptor agonists who are highly selective: Ro 25-1553 and Ro 25-1392 (Gourlet et al., 1997; Xia et al., 1997). In addition a selective VAPC2 receptor antagonist myristoyl-[K12]VIP (1-26)KKGGT has been described (Moreno et al., 2000).

**Table 2: VPAC and PACAP receptors agonist and antagonist:**

	Gene name	Human chromosome location	Selective agonists	Selective antagonist
VPAC1	VIPR1	3p22	Chicken secretin  VIP(1-7)GRF(8-27)-NH <sub>2</sub>	VIP(3-7)GRF(8-27)-NH <sub>2</sub>
VPAC2	VIPR2	7q36.3	Ro 25-1553	myristoyl-[K12]VIP (1-26)KKGGT
PAC1	ADCYAP1R1	7p14	Ro-25-1392 Maxadilan	PACAP(6-38)

VPAC gene receptor expression has also been described in different human carcinomas. VPAC1 receptor expression was found in breast, lung stomach, liver, prostate, colon, and pancreas tumors (Gespach et al., 1988; Moody et al., 2000; Waschek et al., 1995). VPAC2 receptor expression has only been described in the benign leiomyoma (Reubi et al., 2000). Significant differences exist between VPAC1R and VPAC2R, both in structure and in function (Ganea, 1996; Nicole et al., 1998) and there are a number of reports suggesting opposing functions for these two receptors (Tsutsumi et al., 2002; Xia et al., 1996).

These two receptors are highly conserved at the amino acid level suggesting that there may be common principles underlying the molecular mechanisms by which these receptors transduce agonist signals from the extracellular surface to the intracellular

second messenger systems (Segre and Goldring, 1993). It is likely that these receptors have evolved from a common ancestral gene with strong selection pressure to maintain certain key molecular features which are necessary for this mechanism, but diverging in ligand specificity.

In addition to VAPC1 and VPAC2, the receptor PAC1 has been shown to bind PACAP but not VIP. The VPAC2 and PAC1 receptors are 50% identical at the amino acid level, and have 60% identity within the transmembrane spanning domains (the receptor trunk). The PACAP receptors have traditionally been described as type I receptors that bind PACAP with greater affinity (100-1000X) than VIP, and the type II receptors that bind PACAP and VIP with equal affinity (Couvineau et al., 1994; Ishihara et al., 1992).

Name	Relative affinity
VPAC1R VPAC2R PAC1R	PACAP38~PACAP27~VIP PACAP38~PACAP27~VIP PACAP38~PACAP27>>VIP

**Table 3: VPAC receptor subtypes and their affinities (adapted from Rawling) (Rawlings and Hezareh, 1996)**

All these receptors belong to the secretin (Group II) G protein-coupled receptor family, which do not contain the consensus amino acid motifs defined for the rhodopsin/ $\beta$ -adrenergic (Group I) G protein-coupled receptor family (Segre and Goldring, 1993; Wess et al., 1997). Ligands for the secretin receptor family are all relatively large peptide hormones; all members stimulate adenylyl cyclase (AC), apparently through the heterotrimeric Gs protein; but many also couple to phospholipase C (PLC) stimulation through the Gq family (Hezareh et al., 1996; Offermanns and Simon, 1996). Activation of adenylyl cyclases result in production of cyclic AMP and activation of cAMP-dependent processes. Further to their ubiquitous coupling to AC via the heterotrimeric G-protein Gs, a number of the group II GPCR`s can activate additional signalling pathways. VPAC1R and VPAC2R are also able to couple to the IP3/[Ca<sup>2+</sup>]<sub>i</sub> pathway (Langer et al., 2002).

In the model of Langer, VIP induced [Ca<sup>2+</sup>]<sub>i</sub> increases were more efficient in the VPAC1 receptor expressing CHO (Chinese hamster ovary) cells than in VPAC2 receptor expressing cells. VPAC1 receptor coupling can be attributed to both G $\alpha$ q and G $\alpha$ i. VPAC2 receptor coupling to G $\alpha$ 16 increases [Ca<sup>2+</sup>]<sub>i</sub> that allows the coupling of a wide

variety of receptors to phospholipase C. Expression is restricted to hematopoietic and immune cells that express functional VPAC2 receptors (Langer et al., 2002).

To better understand the physiology of these receptors, it is helpful to picture the downstream events that they elicit. The adenylate cyclase activity of VPACR's is probably the most significant downstream aspect of these receptors in T cells. Indeed, in all systems analyzed the VPACR's are associated with the Gs subunit and cause an increase in the cAMPi upon ligand stimulation.

The physiologic downstream effects of increased cAMPi have been investigated in detail. These effects are mainly mediated by activation of the PKA (Protein kinase A) and the subsequent phosphorylation of CREB (cAMP response element binding protein). In the nervous system and in the immune system, the cAMP pathway is involved in inhibition of proliferation, as well as inhibition of apoptosis.

Here it is important to provide some background that may illustrate the significance of cAMP pathway in T cells. A plethora of observations indicate a down regulation of intracellular cAMP upon T cell activation by co-stimulation with antiCD3/CD28. T cell activation is at the same time associated with increased IL-2 production and increased propensity to undergo apoptosis (personal communication with Dr.med. K. Bastani). Upon T cell activation, a T cell specific phosphodiesterase, the PDE7, is upregulated which causes the degradation of intracellular cAMP. On the other hand, increased cAMPi is associated with upregulation of the antiapoptotic protein bcl-2. Memory T cells with a CD45RO phenotype reverts to CD45RA phenotype when they are artificially treated with cAMPi increasing drugs. T cells bearing naïve markers as CD45RA or CD62L have increased amounts of cAMPi. These cells with a naïve phenotype are also more resistant to apoptosis (personal communication with Dr.med. K. Bastani).

VPAC2R activates both adenylyl cyclase and phospholipase C. The VPAC2R was reported to be rapidly phosphorylated, desensitized and internalized after agonist exposure (McDonald et al., 1998).

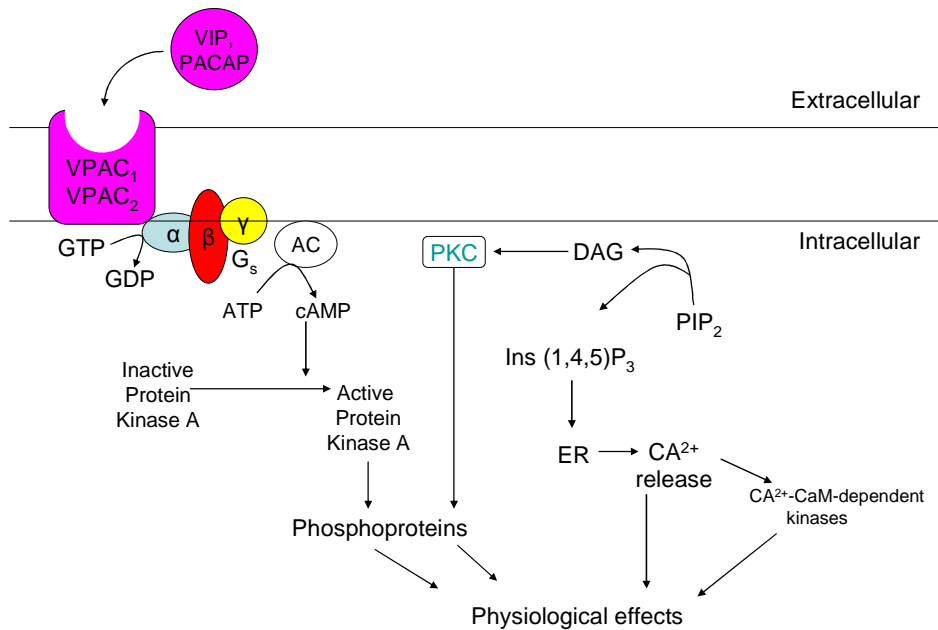

**Figure 3: VPAC receptors pathways**

Main second messenger pathways of VPAC receptors, which are both primarily coupled to the adenylyl cyclase (AC)- stimulate G<sub>s</sub>. Both ligands VIP and PACAP can activate the VPAC1R and VPAC2R with similar binding potency. Abbreviations: GTP, guanosine triphosphate; GDP, guanosine diphosphate; ATP adenosine triphosphate; CaM, calmodulin, PIP<sub>2</sub>, phosphatidylinositol 4,5-bisphosphate; Ins (1,4,5) P<sub>3</sub>, inositol 1,4,5-trisphosphate; ER, endoplasmic reticulum; DAG, diacyl glycerol; PKC, protein kinase C.

(Figure adapted from Dickinson (Dickinson et al., 1999))

Studies with mice deficient for VPAC2 suggest a role in circadian physiology, glucose metabolism, as well as Th differentiation of the murine immune system (Shen et al., 2000). The VPAC2 deficient mice showed increased Th1 cytokine profiles whereas mice expressing a human VPAC2 transgene within the CD4<sup>+</sup> compartment showed a Th2 dominance suggesting an inversion of the phenotype observed in the VPAC2 deficient mice (Goetzl et al., 2001; Voice et al., 2001). The immune and signalling events responsible for the phenotype observed in the KO and transgenic mice have not be

clarified. The wide distribution of VPAC receptors suggests that VIP has many target sites and functions.

### **1.5 Vasoactive Intestinal Peptide (VIP)**

VIP was first isolated by Said & Mutt 1970 from the porcine intestinal duodenum. The amino acid sequence of porcine, canine, dog and rat is identical with the human VIP (Bunnett et al., 1984; Dimaline et al., 1984; Mutt and Said, 1974). VIP is a 28 amino acid neuropeptide and member of the secretin/glucagon hormone family and is described as a potent vasodilator (Barbezat and Grossman, 1971; Said and Mutt, 1970). VIP is found in various tissues, such as lung, liver, brain, thymus, spleen, and intestinal T lymphocyte subtypes (Gozes and Brenneman, 1989). VIP has a number of actions in the periphery, including vasodilatation, stimulation of electrolyte secretion, smooth muscle relaxation and homeostasis of the immune system (Gomariz et al., 2001; Gozes and Brenneman, 1989). VIP is especially abundant throughout the entire enteric nervous system.

#### **1.5.1 Biochemical structure of vasoactive intestinal peptide**

The amino acid sequence of the porcine vasoactive intestinal octacosapeptide: His-Ser-Asp-Ala-Val-Phe-Thr-Asp-Asn-Tyr-Thr-Arg-Leu-Arg-Lys-Gln-Met-Ala-Val-Lys-Lys-Tyr-Leu-Asn-Ser-Ile-Leu-Asn-NH<sub>2</sub> (Mutt and Said, 1974). The VIP gene is located on chromosome 6 (6q24) of the human genome and consists of 9000 base pairs. There are seven exons and each exon codes for a specific functional domain (Gozes and Brenneman, 1989). VIP can act as a neuromodulator, neurotransmitter and secretagogue.

The VIP precursor polypeptide (prepro-VIP) contains sequences encoding additional biologically active peptides, including peptide histidine isoleucine (PHI-27), peptide histidine methionine (PHM) and peptide histidine valine (PHV), which generate a single preproVIP molecule of 170 amino acids (Tatemoto and Mutt, 1981). VIP protein is posttranslational processed by proteases yielding the four peptides, of which three have known biological activity. After VIP is released from nerve cells it binds to the specific VPAC-receptors located on the surface of target cells. Ligand binding is specific,

saturable, reversible and temperature dependent. Much has been published about the subsequent signal transduction and second messenger system involvement. In a simplified form, ligand-receptor interaction activates a GPCR, which in turn activates adenylcyclase which increases intracellular cAMP or alternatively, it activates guanylcyclase and increases cGMP. Both cAMP and cGMP are well known second messengers.

VIP is rapidly metabolized in the human body, with a half life of only about one minute (Domschke et al., 1978). Misbin et al. have investigated the uptake and degradation of VIP by rat livers. The metabolism in the liver and internalization of receptor bound to the VIP peptide with degradation from lysosomes is responsible for its fast metabolism (Luis et al., 1986; Misbin et al., 1982). Because of the high first pass effect of the liver, the plasma concentration of VIP is very low (<20pmol/l) and plays only a minor physiological role.

VIP was originally thought to be only a gastrointestinal hormone. Later Fahrenkrug showed that VIP is also present in the brain and peripheral nervous system thus expanding the role of VIP as a neuropeptide with neurotransmitter and neuromodulator activity started (Fahrenkrug, 1993).

VIP has well documented effects as a potent vasodilator and stimulator of electrolyte secretion (Barbezat and Grossman, 1971) and smooth muscle relaxation (Piper et al., 1970). In the central nervous system, it is involved in regulating cerebral blood flow and circadian rhythms. VIP is a secretagogue for melatonin synthesis and release from pineal gland, insulin release from pancreas, and catecholamine release from adrenal medulla. VIP has a protective role in limiting oxidative damage in various tissues. VIP also stimulates glycogenolysis in the cerebral cortex and regulates cell death and differentiation of the retinal ganglion cells and sympathetic neuroblasts, and the signal induced by acetylcholine seems to be modulated by VIP (Kaiser and Lipton, 1990; Kawatani et al., 1985; Lundberg et al., 1982; Magistretti et al., 1981; Pincus et al., 1990a).

VIP and their receptors have been identified during early neural development and have been implicated in precursor cell mitosis, neurogenesis, and neuronal survival (Gressens



et al., 1993; Waschek, 1996). Moreover, in the immune system, VIP inhibits the proliferation of thymocytes and peripheral T cells (Sun and Ganea, 1993; Xin et al., 1994). In T cells VIP and VPAC1R genes are expressed in double (CD4+CD8+) and single-positive (CD4+CD8-, CD4-CD8+) thymocyte populations, whereas double-negative thymocytes lack expression (Delgado et al., 1996c). Delgado et al showed that VIP protects (CD4+CD8+) thymocytes from dexamethasone induced apoptosis through the VPAC1 receptor (Delgado et al., 1996a).

The neuropeptide PACP was first discovered in 1989 as a hypothalamic hormone that can cause an increase of cAMP in rat anterior pituitary cells (Miyata et al., 1989). PACAP is present in two C-terminal amidated forms, PACAP27 and PACAP38 (27 and 38 amino acids, respectively), it shows a 68% sequence homology with vasoactive intestinal peptide (VIP) in the N-terminal 28 residues (Miyata et al., 1990). A single gene encodes the two known PACAP forms.

VIP            HSD AV FTD N Y TRL RKQMAVKKYL NSI LN

PACAP -38 HSD GI FTD S Y SRY RKQMAVKKYL AAV LGKRYKQRVKNK

PACAP -27 HSD GI FTD S Y SRY RKQMAVKKYL AAV L

**Figure 4: Human sequence comparison of PACAP and VIP**

The sequence of PACAP-38, PACAP-27 and VIP with highlighted similarities. The functional similarity between VIP and PACAP-38 can be seen in the sequence accordance of the two peptides.

Proteolytic processing of a PACAP precursor protein results in the two forms of PACAP (Arimura, 1992). PACAP-containing nerve fibers are present throughout the central and peripheral nervous system. The two molecular forms of PACAP exhibit a broad distribution and range of tissue concentrations. Dramatic changes in the levels of VIP, PACAP, and their receptors in the spinal cord after peripheral nerve injury suggest an important role in neuropathic pain states (MacKenzie et al., 2001).

The biological effects of PACAP are mediated through at least two types of high affinity receptors: the Type I PACAP-preferring receptor and the Type II receptor that does not distinguish between PACAP and VIP, and is referred to as the VPAC receptor. Molecular cloning of receptors with the pharmacological properties of each of these receptors has revealed that they are members of the G protein-coupled receptor superfamily. The recombinant VPAC receptors bind VIP and PACAP with similar affinity and activate adenylyl cyclase. VIP is at least 1000-fold less potent in activating adenylyl cyclase and not active at all in phospholipase C stimulation (Spengler et al., 1993). The recombinant PACAP receptor binds PACAP with an affinity 1000 times higher than that for VIP. VIP binds with high-affinity to VPAC1 and VPAC2 receptors and with low-affinity to PAC1 receptor.

### **1.6 VIP and intracellular signalling**

VIP and PACAP can elicit many different cellular signalling events. This diverse range of indirect or downstream signals includes; activation of adenylyl cyclase, Ca<sup>2+</sup>-dependent processes and protein kinase C activation, nitric oxide synthase/protein kinase G, activation or inhibition of phospholipase A2, activation of tyrosine kinases, activation of extracellular-signal-regulated kinase mitogen-activated protein kinase, inhibition of JNK (c-Jun N-terminal kinase) and JAK (Janus kinase) and activation of phosphoinositide 3-kinase (McCulloch et al., 2002). All VPACR characterized to date stimulate cAMP production and VIP stimulates cAMP in cells with VPAC receptors.

It has also been suggested that several signalling pathways require internalization or sequestration of cell surface receptors by the clathrin-coated pit pathway (MacKenzie et al., 2001). Little is known about endocytosis of GPCRs, but McCulloch found that the VPAC2 receptor expressed in COS7 cells clearly shows greater internalization in cells cotransfected with wild-type arrestin-2. This suggests that for VPAC2 and possibly other group II GPCRs, access to arrestin-and clathrin-dependent routes of internalization may be possible, given the right cellular environment (McCulloch et al., 2002). Both secretin and VPAC2 receptors are probably phosphorylated by GPCR kinases (GRK) and by protein kinase A (McDonald et al., 1998; Shetzline et al., 1998).

Effector	Coupling mechanism	Receptors
AC	Gs	All
PLC	Gα11	PACi-null>PACi-hopI>VPAC2/1
	Gβγ from Gi/o	VPAC2
PLD	ARF	VPAC1/2=PACi-hopI>PACi-null
	Downstream of PLC	PACi-null>PACi-hopI

**Table 4: Multiple signalling pathways from VPAC/PAC1 family receptors after McCulloch (McCulloch et al., 2002)**

Abbreviations: AC, adenylyl cyclase, PLC, phospholipase C, PLD, phospholipase D, PAC, pituitary adenylate cyclase, VIP, vasoactive intestinal peptide.

PACAP and VIP peptides also protect adult neurons from apoptosis. PACAP significantly reduces neuronal apoptosis and cortical infarct size after ischemia (Ohtaki et al., 2006; Uchida et al., 1996). PACAP is frequently several orders of magnitude more potent than VIP in inducing trophic responses, suggesting that the peptide proliferation effects are mediated by PACAP-selective PAC<sub>1</sub> receptors (DiCicco-Bloom et al., 2000).

### 1.7 VIP and rheumatoid arthritis

Rheumatoid arthritis (RA) is a debilitating chronic autoimmune disease of unknown etiology. It is characterized by inflammation in the joint and subsequent destruction of the cartilage and bone with joint deformities. Therapy of RA has been revolutionized over the past few years as new drugs have become available for treatment, but for patients who continue to exhibit signs of inflammation and symptoms, few therapy options remain. The treatment of the disease as discussed in the American College of Rheumatology guidelines is focused on disease modifying medications including methotrexate,

hydroxychloroquin, sulfasalazine and anti-TNF- $\alpha$ -therapy. New treatment strategies concentrate on the use of vasoactive intestinal peptide (VIP).

Studies have shown that in the onset and acute phase of rheumatoid arthritis, a Th1 cytokine response predominates, whereas a Th2 response is associated with remission of the disease. Suppression of Th1 cells and enhancement of Th2 response has been one of the therapeutic approaches proposed for the treatment of RA.

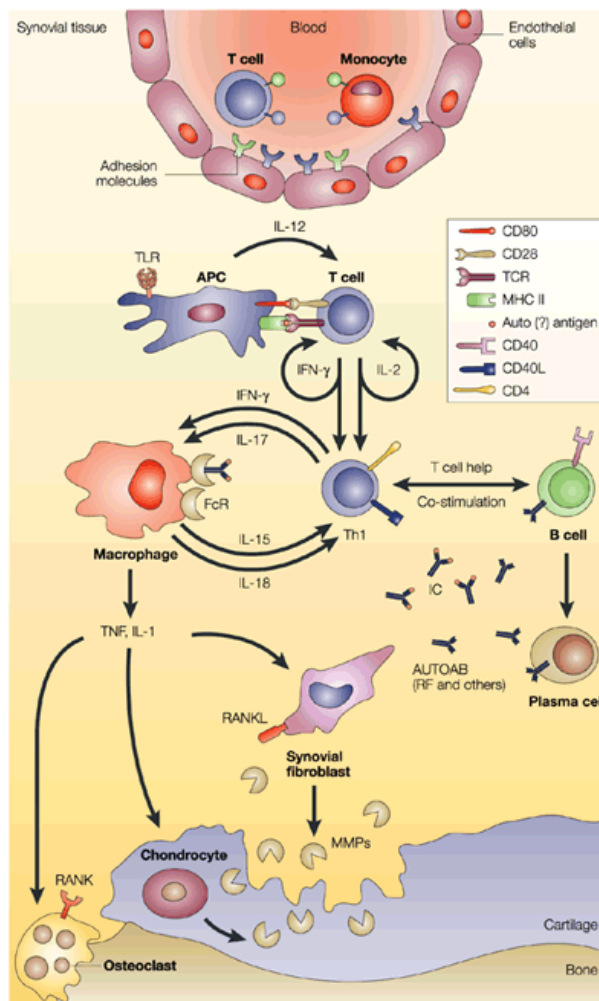

Nature Reviews | Drug Discovery

**Figure 5: Overview of schematic representation of events occurring in rheumatoid arthritis (from Nature Reviews Drug Discovery, Smolen J 2003).**

A growing body of experimental evidence suggests that VIP may exert regulatory effects on lymphocytes, which are generally anti-inflammatory in nature. It has been reported that VIP may inhibit lymphocyte adhesion and trafficking, suppress lymphocyte proliferation and generally decrease the natural killer activity of human and murine lymphocytes (Boudard and Bastide, 1991; de la Fuente et al., 1994; Moore et al., 1988; Rola-Pleszczynski et al., 1985).

VIP biology could thus represent a new strategy for therapy of rheumatoid arthritis based on its effect on T-cell response. VIP has a suppressive effect on Th1 responses (demonstrated by decreased IFN- $\gamma$  expression) as shown by several authors (Delgado et al., 1999; Goetzl et al., 2001; Voice et al., 2001). Macrophages and dendritic cells treated with VIP *in vitro* induce Th2-type cytokine release (IL-4 and IL-5) and inhibited Th-1 cytokine release (IFN- $\gamma$  and IL-2) in CD4 T cells (Delgado et al., 1999). VIP receptor deficient mice show an increased Th-1 type response as delayed-type hypersensitivity, whereas mice overexpressing VIP receptor show eosinophilia with high IgE and IgG1 level and a typical cutaneous anaphylaxis as typical Th-2 response (Goetzl et al., 2001; Voice et al., 2001).

In an animal model, treatment with VIP was found to significantly reduce the incidence and severity of collagen-induced arthritis, abrogating joint swelling and destruction of cartilage and bone. RA-like symptoms were induced by immunization of mice with type II collagen. After two immunizations VIP was administered in different doses and different injection time points for a period of two weeks. They could also show VIP blocks disease in mice that had already shown symptoms (Delgado et al., 2001).

#### Vasoactive Intestinal Peptide in Immunity

1. Prominent quantitatively in thymus, spleen, and body surface associated lymphoid tissues
2. Evokes T cell and macrophage trans-tissue migration.
3. Regulates T cell and macrophage generation of cytokines.
4. Alters T cell-dependent production of immunoglobulins.

5. Biases immune response toward immediate hypersensitivity and inflammation.
6. Involvement in T cell apoptosis.

### **1.8 Hypothesis**

mRNA splicing events lead to a number of variant forms of the PAC1 receptor with subtly different properties. At least five splice variants of the closely related rat PACAP receptor differing only in their predicted third intracellular domains, a region implicated in coupling of a variety of receptors to G proteins, are known. The short splice variant form of the receptor was designated PACAPR with the longer splice variant forms designated as hip, hop, or hip-hop isoforms of the PACAPR (Spengler et al., 1993). Four of these splice variants exhibited the multifunction signalling characteristics of PACAP receptors found in various cells, activating both adenylyl cyclase and inositol-phospholipid-specific phospholipase C, while one variant activated only adenylyl cyclase (Spengler et al., 1993).

To our knowledge, there have been no previous reports of splice variants of the VPAC2 receptor. We hypothesized that splice-variants of VPAC2 receptor may exist in murine tissues as an additional control mechanism to regulate its function.

The purpose of the present study was to use a PCR-based search to identify alternatively spliced mouse VPAC2 receptor expressed in different mouse tissues, and to thus, better characterize the biology of the VPAC2 receptor. The splice variant subsequently identified was further investigated by comparing the functional properties of mouse VPAC1 and the variant VPAC2 deletion after stable expression in human Jurkat T cells.

Objectives of the study:

- Understanding the molecular mechanism of the VPAC receptors.
- Generation of VPAC1R and deletion variant VPAC2R stable transfectants in a human T cell line.
- Determining whether or not VPACR expression is associated with an increased intracellular cyclic AMP and influence of the known ligands on cAMPi.
- Better understanding the role of VPAC receptors in T cell migration.

## **2. MATERIALS**

### **2.1 Bacteria**

Stratagene # 200236: XL1-Blue Supercompetent cells recA1, endA1, gyrA96, thi-1, hsdR17, supE44, relA1, lac [F' proAB lacIqZΔM15Tn10(Tet')]

### **2.2 Vectors**

#### **pBluescript II KS (+): phagemid vector**

f1 (-) ori, ColE1 ori, lacI (not functional), lacZ (for blue-white-selection), multiple cloning sites with flanking regions T3- und T7-Promotor, ampicillin resistant, size 3.0 kb.

#### **pIRESneo3 Vector purchased from BD Biosciences (Cat #: 6988-1)**

The vector was designed for the production of stable cell lines expressing proteins in mammalian cells. This vector contains the internal ribosome entry site (IRES) of the encephalomyocarditis virus (ECMV). This combination permits both the gene of interest and the neomycin selection marker to be translated from a single mRNA.

Other features: multiple cloning sites, ampicillin resistant plasmid size 5.3 kb



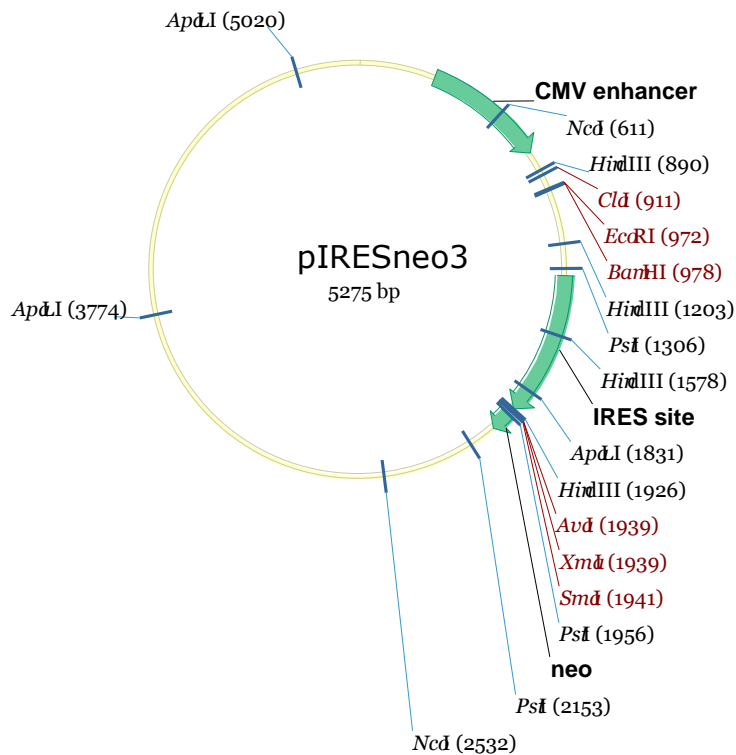

**Figure 6: pIRES vector**

### 2.3 Cells

The cells used in this study are acute human T cell leukemia Jurkat Clone E6-1 (reference American Type Culture Collection (ATCC) TIB-152 Log # AO3823). The cells were purchased from the University of California (UCSF) tissue culture facility. Endogenous levels of the receptors could not be detected by realtime PCR (data not shown). The Jurkat T cell line was transfected with the vector. The resultant cell lines were maintained in RPMI 1640 medium supplemented with 10% fetal bovine serum, 1% Penicillin-Streptomycin, and 500 µg/ml G 418 sulfate (Geneticin).

## **2.4 Mice**

Wild-type C57BL/6 mice were ordered from Jackson Laboratory and housed at the animal facility at UCSF.

## **2.5 Oligonucleotides**

The DNA oligonucleotides and the fluorometric-based kinetic RT-PCR primer & probes were purchased from Integrated DNA Technologies.

## **2.6 Enzymes**

Applied Biosystems: AmpliTaq Gold polymerase

New England Biolabs: all restrictionenzymes (EcoRI, SpeI), T4 DNA-Polymerase

Roche: DNaseI, RNaseI, Expand High fidelity PCR system

Gibco BRL Life Technologies: RNAout

Qiagen: reverse transcriptase

Invitrogen: Taq DNA Polymerase recombinant

## **2.7 Chemicals and reagents**

Applied Biosystems: PCR buffer, MgCl<sub>2</sub>, plates and caps for fluorometric-based kinetic based RT-PCR

Bio Whittaker Molecular Applications: Seakam® GTG® agarose

Bio 101 systems: LB-Medium, LB-Agar Medium

Calbiochem: G 418 Sulfate, albumin bovine serum fraction V fatty acid-free.

Gibco BRL Life Technologies: pyrogen-free water.

Invitrogen: Agarose, TRIzol® reagent # 15596-018, 100 bp DNA ladder

Peptotech Inc: recombinant human SDF-1  $\alpha$

Perkin Elmer: radioactive isotope [<sup>125</sup>I]-VIP (2200Ci/mmol, 638μCi/μg).

Promega: set of dATP, dCTP, dGTP, dTTP

Roche: TaqExpand #1732641

Sekam: GTG Agarose (ligase free for cloning)

Sigma: mouse collagen Typ IV, VIP (V6130-250UG), Ethidiumbromid

UCSF tissue culture facility: RPMI 1640 with HEPES 25mM, 1x PBS (without Ca<sup>2+</sup> and Mg<sup>2+</sup>), fetal bovine serum heatinactivated,

All chemicals and reagents were purchased from Sigma (St Louis, MO, USA), Gibco-BRL (USA), Calbiochem (USA), Invitrogen (USA), Promega (Madison, WI, USA), Qiagen (Germany), Roche unless otherwise indicated

R&D system cAMP kit (low ph) #KGE002

Radioactiv labeled I<sup>125</sup>-VIP

## 2.8 Antibodies

BD Biosciences: purified rat anti-mouse CD16/CD32 (Fcγ III/II Receptor, mouse Fc Block™) monoclonal Ab, purified hamster anti-mouse CD28 monoclonal Ab, purified anti-mouse CD3 ε chain (145-2C11), FITC labeled anti-mouse CD4 (L3T4) (RM4-4), FITC labeled mouse IgG2b κ isotype control, PE labeled anti-mouse CD25 (IL-2 Receptor α chain, p55), PE labeled mouse IgG1 κ isotype control

## 2.9 Solutions, media and buffer

### LB Medium

Bactrotrypton	10g
Yeast extract	10g
NaCl	5g
H2O dl	1l

### **LB plates**

LB-medium with 1,2% Bactoagar

### **10X PBS**

NaCL	80g
Na <sub>2</sub> HPO <sub>4</sub>	11.5g
KCL	2g
KH <sub>2</sub> PO <sub>4</sub>	2g
H <sub>2</sub> O dl	1l

### **TBE-Buffer (Tris-borate/EDTA)**

Tris-base	54.0g
Boric acid	27.5g
0.5 M EDTA (ph 8.0)	20 ml
H <sub>2</sub> O dl	5l

### **Cell culture growth medium for Jurkat cells**

#### **RPMI 1640**

FBS heat inactivated 10%

Penicillin	200 U/ml
Streptomycin	200 U/ml

## **Cell culture**

The Jurkat cells were cultivated in RPMI 1640 medium. Cells were incubated in the following conditions: 37 °C, 5% CO<sub>2</sub>, 96% humidity, medium was changed every third day.

## **DEPC treatment of water solutions:**

To 1l of water solution 1 ml of diethylpyrocarbonat (DEPC) was added and the solution was incubated overnight at 37°C. Subsequent DEPC was inactivated through autoclaving.

## **Other materials**

For all experiments we used water filtered through Millipore (Milli-Q). For all enzymatic reactions it was autoclaved before use. Neubauer hemacytometer was used for cell counting from Fisher Scientific, Pittsburgh, PA.

## **2.10 Instruments**

Applied Biosystem: 7700 sequence detector thermocycler

Beckman instruments: centrifuge

Bio-Rad laboratories:

Dynex Technologies: ELISA reader MRX revelation

FACScan Becton Dickinson, Mountain View, CA

TOMY MTX-150: table centrifuge

Stratagene: Robocycler 40 temperature cycler

## **2.11 Software**

CELL Quest (Beckton Dickinson, Mountain View, CA, USA)

Easybound (non-linear regression tool from P.Heuler & G. von Euler, download online available)

Excel 5.0 (Microsoft, USA)

### **3. METHODS**

#### **3.1 RNA Isolation from mouse tissue**

Different tissues cell suspensions from a 6-wk-old C57BL/6 mouse (lung, spleen and thymus) were centrifuged, washed with 1x PBS, and lysed with 1ml of TRIzol® (Invitrogen) (50-100mg tissue) and RNA was isolated according to the manufacturer's protocol. Briefly the protocol contains following steps: tissue homogenization, phase separation, RNA precipitation, RNA wash with 75% ethanol and redissolving RNA in water (RNase free).

#### **3.2 DNase I digestion of RNA**

DNase I treatment eliminates DNA from the purified total RNA, to prevent amplification of genomic DNA targets in PCR. The final volume of reaction mix was 15 µl. The following reaction mix was incubated at room temperature for 15 min: RNA 10 µl, DNase 2 µl (1U/µl), DNase buffer 1.5 µl and water. To inactivate DNase 1 µl of 25 mM EDTA solution was added to the reaction mix and heat for 10 minutes at 65°C.

#### **3.3 First strand cDNA Synthesis for PCR**

DNase-treated RNA was used for the synthesis of single-strand DNA with the Qiagen Omniscript RT kit. The kit contains reverse transcriptase, 10x transcriptase buffer, dNTPmix and H<sub>2</sub>O. Rnase inhibitor (10 units/µl) and Oligo-dt primer (10µM) was added purchased from invitrogen. Afterwards 10 µg total RNA was absorbed in 12 µl water.

To this RNA preparation the following master mix was added; 2 µl (10µM) Oligo-dt primer, 1 µl Rnase inhibitor (10 units/µl), 2 µl 10X transcriptase buffer, 2 µl dNTP (5mM/each), 1 µl reverse transcriptase enzyme. The final reaction volume 20 µl was incubated for 1 hour at 37°C. Afterwards the preparation was stored at -20°C or 1 µl cDNA was used for one PCR reaction.

### **3.4 Cleaning methods for nucleic acid**

**3.4.1 Phenol extraction:** To exclude proteins of the DNA preparation (minimum 100 µl) we added the same volume of TE saturated Phenol and vortexed for 1 min. Afterwards the mixture was centrifuged 3 min at 13000 rpm. The aqueous solution on top was transferred in a new tube and the same volume chloroform/isoamylalcohol (24:1) was added vortexed for 1 min and centrifuged 3 min at 13000 rpm. The aqueous solution contains the DNA preparation free of protein.

**3.4.2 Ethanol precipitation:** The DNA preparation was mixed with 1/10 volume 3M natriumacetat (ph 4.8), subsequently 2.5 volume -20°C absolute ethanol was added. The mixture was gently mixed and for at least 1 hour at -20°C or for 20 minutes at -80°C stored. The DNA pellet was afterwards centrifuged for 30 minutes at 13000 rpm at 4°C. The precipitation was washed with 0.5 ml -20°C absolute ethanol and then air dried for a couple of minutes before resolved in suitable volume of water (DEPC-treated). The nucleic acid concentration of the sample is determined with a photometer.

### **3.5 Amplification of DNA with PCR**

Polymerase chain reaction (PCR) (after Saiki 1985) was used to amplify single or double target DNA fragments selective *in vitro*. The purpose of PCR is to make increased numbers of copies of a gene. The double-strand genomic DNA is melted with heat into two single strands, which can bind specific to oligonucleotide primer (20 nt long) that flank the DNA fragment of interest to start the polymerase reaction. The DNA-polymerase adds complementary nucleotides to the 3'OH end of the primer to generate a new double-strand. In the next step the double-strand DNA is separated to a single – strand DNA through heat and the reaction can start again. The cycles are repeated arbitrary, so during the first 30 cycles there is an exponential amplification of the examined DNA fragment. One important condition for the success of the reaction is that the primers bind specifically. The primer sequence must be known for specific synthesis.



The PCR is performed using a thermocycler which was programmed with temperature, time and cycle frequency.

Overview of the PCR steps:

1. Denaturation of matrix DNA: 94°C
2. Annealing of primer: between 58-62°C around 1 min
3. DNA synthesis: 72°C depending on the amplification length, for 500 bp around 30 s, most of the times 35 cycles were used.

For PCR thermostabil Polymerases “Expand High fidelity PCR system (Roche), Ampli Taq Gold Polymerase (Applied Biosystems), Taq DNA Polymerase recombinant (invitrogen), thin-wall tubes and the thermo block Robocycler 40 (Stratagene) were used. A PCR reaction mix of 25 µl consisting of the following reagents: 1X buffer, dNTP (0.2 mM), Taq polymerase (1 µl/100 µl), Mg (1.5 mM), H<sub>2</sub>O +primer (25 pmol 3’ and 5’) + cDNA (1 µl) was used. Following PCR amplification, the PCR products were analyzed with electrophoresis. Electrophoreses PCR product aliquots were transferred (10 µl) on a 1.5% agarose gel (stained with ethidiumbromide) and lanes with DNA molecular weight marker were included. The 6X probe buffer (with bromphenolblue dye) at a volume 1/10 was added to the DNA product before transfer. The 1.5% agarosegel was generated as following: 22.5g agarose was mixed with 150 ml 1X TBE and heated up in the microwave for 1 min until the solution was clear. Than the gel solution cooled down and 0.5 µg/ml ethidiumbromide was added. The solution was poured warm in the gel chamber and was than loaded. (Loading buffer was 1X TBE)

The electrophoresis was performed at 100 V for a gel size of 12x14 cm<sup>2</sup> (150 ml gel).

Primer name	Primer sequence	Product size	Annealing temperature
<b>T7 sequencing</b>	R: 5'-GAA TTG TAA TAC GAC TCA CTA TAG-3'		
<b>pBluescript KS(-) T3 sequencing mHPRT</b>	5'-CTC GAA ATT AAC CCT CAC TAA A-3' F:5'-CTG GTG AAA AGG ACC TCT CG-3'	108 bp	55°C
<b>HPRT-Spel</b>	R:5'-TGA AGT ACT CAT TAT AGT CAA GGG CA-3' F:5'-GAC TAG TCC GCC ATG GCG ACC CGC AGT CCC AG-3'	657 bp	65°C
<b>HPRT-EcoRI</b>	R:5'-GGA ATT CTT AGG CTT TGT ATT TGG CTT TTC CAG TTT CAC-3'		
<b>mVPAC2</b>	F:5'-AGA TGT TGG TGG CAA TGA CCA G-3' R: 5'-GTA GTG GAC GCC AAA CAG GG-3'	78 bp	63°C
<b>mVPAC2 E11 sequencing mVPAC1 E11 sequencing pIRES</b>	F: 5'-ACT TTT GCG TTG ATG AAG TCT CTG CTT TCT GTT-3' R: 5'- TGT ATT TCT AGA TGA AAG CGA CAT TCT GGA TGG-3' R: 5'-GTGGACGCCAAACAGGG-3' R: 5'-GGGAAGAAGGCAAACATGACATAG-3' F: 5'-CTC ACT ATA GGG AGA CCC AAG CTT-3'		
<b>mVPAC1</b>	R: 5'-CGC TTT TGA GAG GGA GTA CTC AC-3' F:5'-CCG AAT CCT GGT TCA GAA GCT-3'	134 bp	58°C
<b>mVPAC2-EcoRI test Jurkat mVPAC2-Spel</b>	R:5'-GGG AAG AAG GCA AAC ATG ACA TAG-3' R: 5'-GGA ATT CCT AAA TGA CTG AAG TCT CTG ACT GCA GGA-3' F:5'-GAC TAG TCC ACC ATG AGG GCG TCG GTG GTG CTG A-3'	1314 bp	59°C 65°C 65°C
<b>mVPAC2ex10F</b>	F:5'-GAGTTATGTGTTGGTTCCTTCCA-3'		59°C
<b>mVPAC2ex11R</b>	R: 5'-GCCATCTTCTTTTCAGTTCACAC-3'		
<b>Intron splicing mVPAC1-EcoRI test Jurkat mVPAC1-Spel</b>	R: 5'-GGA ATT CTC AGA CCA GGG AGA CCT CCG CTT-3' F: 5'-GAC TAG TCC ACC ATG CGC CCT CCG AGC CTA CC-3'	1380 bp	65°C 65°C

**Table 5: Primer sequences used**

### 3.6 Cloning of the mVPAC1 and mVPAC2 receptor

In order to obtain the full-length mVPAC1 and mVPAC2 cDNA, RNA was isolated from thymus, spleen and lung tissues of normal 6–8-week-old C57BL/6 male mice. After sacrificing the animal by cervical dislocation, the tissue was immediately put in TRIzol® and RNA (expected 30-100 µg RNA) was isolated according to the manufacturers' protocol. RNA was DNase-treated for 30 minutes at 37°C. The synthesis of first-strand cDNAs was performed using the Superscript II system (Invitrogen). VPAC<sub>2</sub> DNAs in the first-strand cDNA array were amplified by PCR with platinum TaqDNA polymerase (Invitrogen) and primers for sequences at the ends of the coding region: 5'-gac tag tcc acc atg agg gcg tcg gtg gtg ctg a-3' (forward (SpeI)) and 5'-gga att cct aaa tga ctg aag tct ctg act gca gga a-3' (reverse (EcoRI)) VPAC1 primers 5'- gac tag tcc acc atg agg gcg tcg gtg gtg ctg a -3' (forward (SpeI)) and 5'-gggaagaaggcaaacatgacatag -3' (reverse (EcoRI)). Mouse VPAC1 and VPAC2 containing the open reading frame was amplified using High Fidelity Taq DNA polymerase (Roche) with following reaction conditions: 95°C 2 min for one cycle, 95°C 45 s, 60°C 1 min, 72°C 2 min for 3 cycles, 95°C 45 s, 65°C 1 min, 72°C 5 min for 30 cycles.

PCR products were separated on a 1% clean agarose gel and visualized by ethidium bromide fluorescence. The expected size of the mVPAC1 PCR product was 1380 bp, for mVPAC2 1314 bp and for mHPRT 657 bp (see picture next page). The PCR products were digested with the restriction enzymes SpeI and EcoRI.

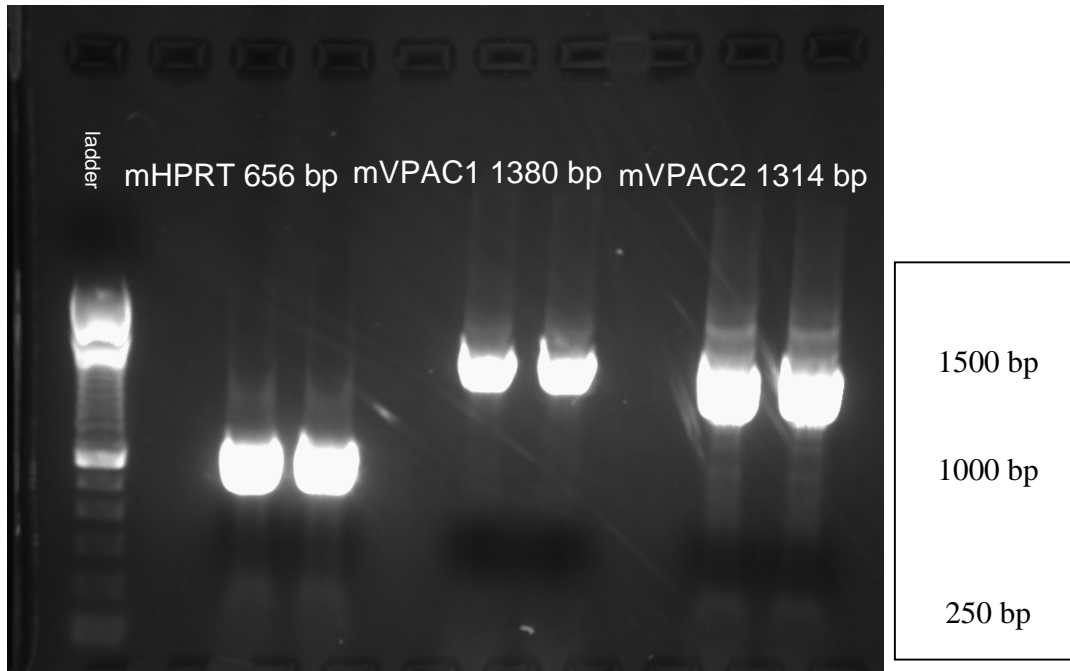

***Picture 1: Cloning PCR from mouse lung tissue mHPRT 656 bp (left), mVPAC1 1380 bp (middle) and mVPAC2 1314 bp (right) (all three in double bands; primer EcoRI/SpeI, ladder from 250 to 2000bp).***

Individual VPAC2 DNAs were isolated by 1% agarose gel electrophoresis and introduced into pBluescript II SK(+) phagemids (Stratagene, La Jolla, CA) at the SpeI/EcoRI sites for transformation into XL2-Blue MRF' Ultracompetent cells. Selection of colonies with PCR-detectable VPAC2 inserts in plasmid mini-preparations (Qiagen, Valencia, CA), and determination of the sequences of these VPAC2 DNAs with primers for vector sequences: 5'-ctcgaaattaaccctcactaaa-3' (forward) and 5'-gtggacgcccaaacaggg -3' (reverse) (ELIM Biopharmaceuticals, Inc., Hayward, CA) was performed. Multiple DNAs encoding wild-type and deletion-variant VPAC2 receptors were subcloned into the pIRESneo3 bicistronic expression vector (BD Biosciences) at the NheI/EcoRI sites and re-sequenced with the pIRES primers: 5'-ctcactatagggagacccaagctt-3' (forward) and 5'-cgcttttgagagggagtactcac-3' (reverse).

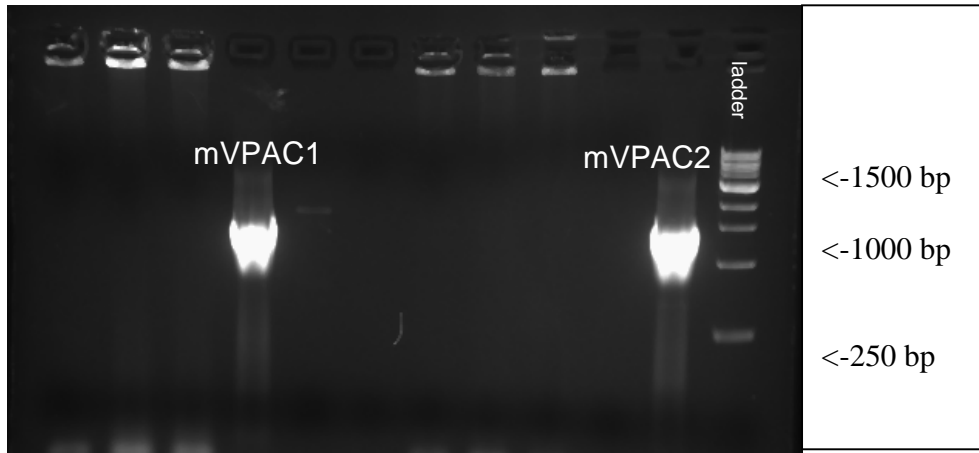

*Picture 2: PCR of Jurkat transfectants mVPAC1 1380 bp and mVPAC2 1314 bp, ladder from 250 to 2000 bp.*

### 3.6.1 Plates culture and solution cultures

LB-medium was autoclaved with 15g/l agar-agar. After cooling down to 55°C the ampicillin 100µg/ml for antibiotic selection was added. The warm medium was filled into sterile petri dishes plates. The plates will be dried for 30 minutes at 37°C. The dried plates can be stored for weeks at 4°C. The bacteria were poured after transformation on the dried plates (37°C for 30 minutes) 500 ml LB-medium (Ampicillin added) were transfected with one single colony and shook overnight at 37°C with 280 Upm.

### 3.6.2 Isolation of DNA fragments from agarose gels

The specific DNA fragment (2 bands) were cut from the gel with a sharp scalpel and put into tubes, weighed gel (160-200 mg) and treated by following the instructions of the gel extraction kit (Qiagen). The plasmid DNA was isolated from the gel (3000 bp) after digestion with EcoRI and SpeI the gel extraction kit was used according to the protocol. The pBluescript phagemid vector was also cut with the same restriction enzymes.

### **3.6.3 Ligation of the plasmid**

The fragment was subsequently cloned into the *NheI* (compatible ends with *SpeI*) and *EcoRI* sites of the eukaryotic expression vector pIRESneo. After transformation of *E. Coli* bacteria with the new constructs, single colonies were picked and the cloned sequences identified by DNA sequencing (performed by ELIM company).

### **3.6.4 Transformation protocol**

The ultracompetent bacteria's were thawed on ice and 5  $\mu$ l of ligation mixture was added to 100  $\mu$ l of bacteria which was gently swirled. The bacteria were incubated on ice for 15 minutes, heat-pulse the tubes in a 42°C water bath 20 seconds, incubated on ice for 2 minutes. Then 0.9 ml of preheated (42°C) NZY+ broth was added and the tubes were incubated at 37°C for 45 minute with shaking at 225-250 rpm. 50  $\mu$ l or 5  $\mu$ l of the bacteria were plated on LB-agar plates (ampicillin 100  $\mu$ g/ml) and incubated overnight at 37°C.

### **3.6.5 Generation of stable human Jurkat T cells transfectants**

The introduction of a specific DNA segment into the Jurkat T cells was performed by transfection of the expression plasmid into the cells. The Jurkat T cell line is an immortalized human leukemic T cell line. Jurkat T cells are particularly robust producers of IL-2 after stimulation with phytohaemagglutinin (PHA) (Abraham and Weiss, 2004).

### **3.6.6 Electroporation**

Electroporation was used for transfection. This method is suitable for cells in suspension such as the Jurkat T cells. The cells and DNA fragment were treated for milliseconds under an electric field, such that the DNA fragments penetrated into the cells. The cells were first centrifuged 5 min at 300 x g and washed with 10 ml PBS resuspended and counted. After a second centrifugation, the cells were resuspended at a concentration of  $1.2 \times 10^7$  cells in 800  $\mu$ l PBS.

Jurkat cell suspension was then mixed with 20 µg linearized DNA (mVPAC1, pIRES or mVPAC2 deletion/intron11) construct. The cell suspension was filled into a sterile electroporation cuvette with 4mm electrode distance, and was electroporated at 240 Volt/500 µF. The cell suspension was incubated for 10 minutes on ice and then transferred into a cell culture flask ( $2.5 \times 10^6$  cells) with regular growth medium.

After 24 h, the Jurkat cells were washed and cultured for 2 days in complete RPMI 1640 medium containing 10% fetal bovine plasma, 100 units/ml penicillin G, and 50 µg/ml streptomycin. Geneticin (Invitrogen) then was added to the cultures in steps of 200, 400, and 600 µg/ml every 4–6 days.

### 3.7 Ligand competitive binding assay

Binding assays can provide information about the affinity of sites as well as the total number of binding sites per cell. Binding assays involve a timed incubation with the radioligand and the cells expressing the receptor of interest at optimized temperature and conditions. Binding is allowed to proceed until it reaches equilibrium. Termination of the assay separates free from bound and the radioactivity remaining counted. The existence and characterization of specific VIP binding sites on immune cells and lymphocytic cell lines has been documented initially through binding studies (Delgado et al., 1996b).

Parameter	Brain homogenate	Brain slices	Pancreatic acini
Radiolabeled probe	[125I] VIP	[125I] VIP	[125I] VIP
Buffer	50 mM HEPES	Krebs-Ringer	Krebs-Ringer
Temperature (°C)	37	25	37
K <sub>D</sub> (nM)	3,62	3,28	0,9
Density	0.2, 8.4 pmol/mg	0.3, 1.5 pmol/mg	9000 per cell

*Table 6: VIP Receptor Binding Properties (after Moody T 1986)*

In order to estimate the binding of an agonist we determined <sup>125</sup>I-iodine-VIP binding using live cell suspensions. The cold PBS washed cell suspension at 1Mio/well was resuspended in 25 µl binding media containing: RPMI 1640 with Hepes 25 mM, 1% BSA, 0.05% Azide and incubated with 25 µl of different concentrations of VIP 10<sup>-6</sup> M to 10<sup>-10</sup> M. Then 25 µl radioactive <sup>125</sup>I-VIP was added at a concentration of 10<sup>-9</sup> M. The plate was incubated under constant shaking at room temperature for 1.5 hours. Subsequently the cell suspension (total 100 µl) was put on top of 800 µl cold 10% sucrose and centrifuged 3000 rpm at 4 °C through this gradient for 10 minutes. Very slowly the top layer of about 800 µl was removed and the left cell suspension was transferred into counting tube. The result was determined by using a Packard Cobra Auto-gamma counter and Easybound software.

### **3.8 cAMP ELISA assay**

For the quantitative determination of cyclic AMP (cAMP) concentrations in the cells we used an R&D systems USA cAMP (low pH) kit. Adenosine 3',5'-cyclic monophosphate (cAMP) is ubiquitous second messenger involved in various cellular activities in many cell and tissue types. Receptor-mediated activation of the G protein activates adenylate cyclase (AC) by generating cAMP from ATP and subsequently activating protein kinase A (PKA).

This assay is based on the competitive binding technique in which cAMP present in a sample competes with a fixed amount of horseradish peroxidase (HRP)-labeled cAMP for sites on a mouse monoclonal antibody. The monoclonal antibody becomes bound during the incubation time to the goat anti-mouse antibody coated on the microplate. The microplate is washed to remove excess conjugate and unbound sample. To determine the bound enzyme activity a substrate solution is added. Afterwards the color development is stopped and the absorbance is read at 450 nm by a plate reader. The intensity of the color is inversely proportional to the concentration of cAMP in the sample.



The cells were washed twice with RPMI put into a 96 well/plate and pretreated with phosphodiesteraseinhibitor 3-isobutyl-1-methylxanthine (IBMX 0.6mM) at 37°C for 15 minutes. VIP in different concentrations ( $10^{-6}$  M to  $10^{-9}$  M) was added, and after an additional incubation time at 37°C for 15 minutes, was followed three washes with 0.9% NaCl, the cells were lysed with the provided 0.1 N HCL solution. After adequate lysis had occurred, the samples were centrifuged at 600 xg and assayed immediately or stored at -20°C.

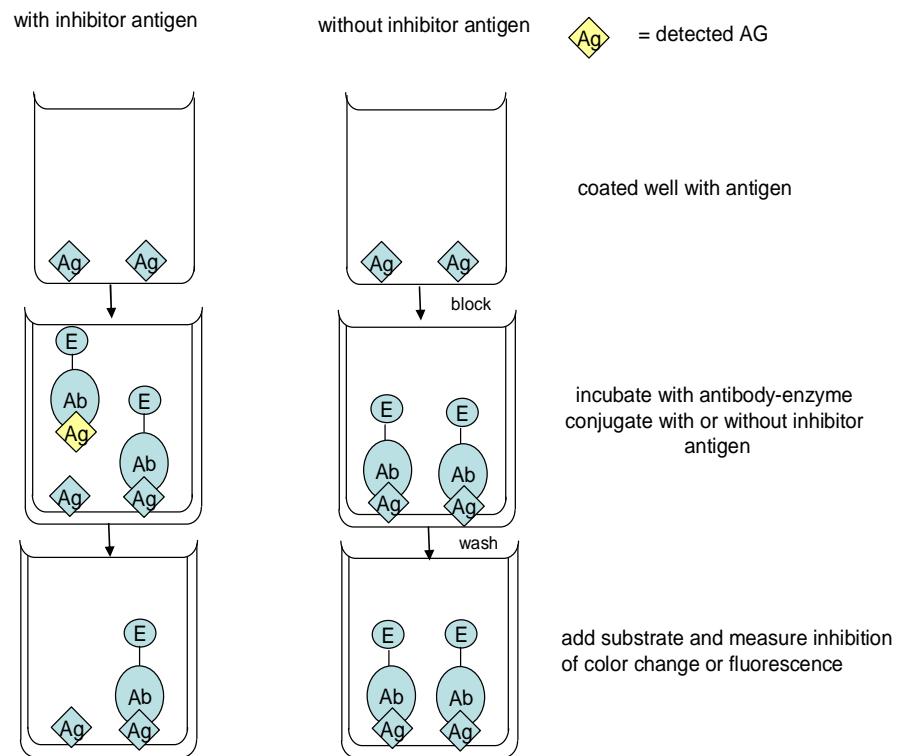
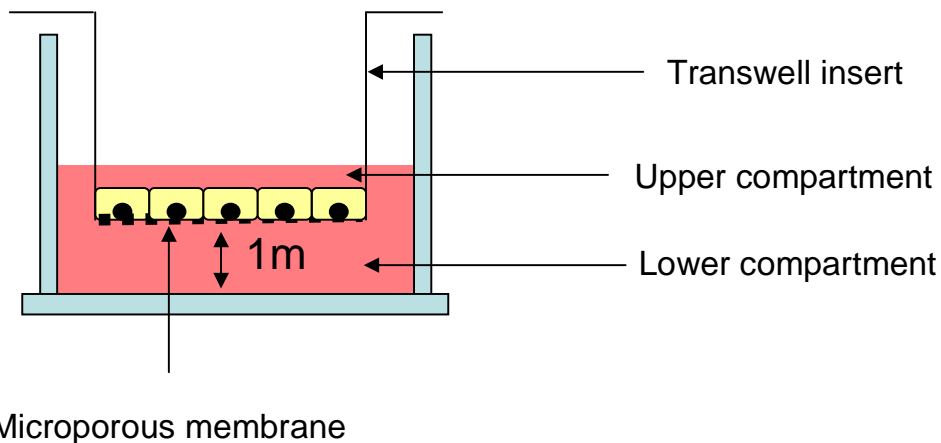

**Figure 7: Direct competitive ELISA to detect soluble antigens. Abbreviations: Ag: antigen; Ab: antibody; E: enzyme.**

### **3.9 Transwell migration assay**

Cell migration is a fundamental function of normal cellular processes, including angiogenesis, embryonic development, wound healing, inflammation and immune response. Costar Transwell® cell culture chamber 6,5 mm with 5 µm pore size filter were coated on the lower side with mouse collagen type IV (10 µg/ml) over night at 4°C, washed twice with PBS and air-dried. The lymphocyte cell suspension 2 Mio/200 µl was placed on top of the filter. In the lower chamber different concentrations of stimulus was added to make 500 µl. The plate was then incubated for 6 hours at 37°C. Afterwards the whole 500 µl in the bottom chamber was centrifuged, and resuspended in 100 µl trypan blue stain 0.4%. The dye exclusion test was used to determine the number of viable cells present in a cell suspension. It is based on the principle that live cells possess intact cell membranes that exclude certain dyes, such as trypan blue, whereas dead cells do not. In this test, a cell suspension was simply mixed with dye and then visually examined to determine whether cells take up or exclude dye. 10 µl of the total volume was used to count with a Neubauer hemacytometer. To count cells, 10 µl of the culture was applied to a clean, covered hemacytometer. Upon examination under a microscope, the cells in each corner square are counted and averaged. Using these numbers, the total number of cells per ml of culture was determined ( $\text{cells/ml} = \text{counted cells} / 4 \times \text{dilution} \times 10^4$ ).

Statistical analysis was performed using an unpaired t-test.



**Figure 8: Transwell® permeable Support.** The porous bottom of the insert provides independent access to both sides to the cells.

### 3.10 Flow cytometry apoptosis assay with 7-AAD

Fluorescence-activated cell sorting (FACS) was performed to quantify the expression of 7-Amino-actinomycin D (7-AAD) on the surface of the Jurkat T cells. Flow cytometry is a method to analyze the presence of antigens on cells by immunofluorescence. The cells will be labeled with a fluorescent antibody and then analyzed using a flow cytometer.

Due to the fragility of cells undergoing programmed cell death, rapid methods that maintain cells as close as possible to their natural state were used to provide the most reliable results. The rapid 7-AAD staining method uses unfixed cells and thus permits the detection of changes in light scatter parameters and their correlation with other indicators of programmed cell death. However, one drawback of using any live staining method for measuring apoptosis is the variability of dye uptake in different cells and its possible change through certain treatment conditions.

#### Principle of the assay

Apoptotic cells, probably due to a change in membrane permeability, take up some 7-AAD and become 7-AAD<sub>dim</sub> compared to live cells which remain 7-AAD<sub>bright</sub>. Late

apoptotic or necrotic cells which have lost membrane integrity appear 7-AAD<sub>bright</sub> (Philpott et al., 1996; Schmid et al., 1994).

### **Preparation of 7-AAD stock solution**

Dissolve 7-AAD powder (1mg) first in 50  $\mu$ l of absolute methanol, and then add 950  $\mu$ l of 1 X PBS. Final concentration is 1mg/ml. Keep solution at 4°C protected from light. Solution can be stored for at least up to 6 months.

Jurkat transfectants were incubated at  $1 \times 10^6$  cells/ml overnight in fresh RPMI medium containing 10% FBS. Triplicates of cultured cells were incubated on ice for 60 minutes in polystyrene tubes with 20  $\mu$ l 7-AAD (7-amino-Actinomycin D) and subsequent analyzed in flow cytometry. Analysis was performed with CellQuest software program.

### **3.11 Statistics**

Data was analyzed by the Student's *t* test for independent samples.

## **4. Results**

### **4.1 Alternative splicing of VPAC2 receptor**

In our effort to isolate mVPAC2 splice variants, we used a series of different mouse tissues for our PCR based search. At the time of the studies, the full-length cDNA of VPAC2 had not been cloned from the mouse thymus, spleen or lung. Since high expression levels of VPAC1 and VPAC2 are known to be present in the lung, we used mouse lung mRNA as the source for cloning.

A mouse VPAC2-specific primer designed within the 3' untranslated region was used in reverse transcription reactions (mVPAC2 RT primer) and VPAC2 specific cDNAs were synthesized using the RT primer and mRNAs isolated from the mouse thymus, spleen and the lung. Subsequently, using the aforementioned mVPAC2 cDNAs as templates, PCR's were performed in order to amplify the full-length translated region of VPAC2. The ends of the PCR products were digested with the restriction enzymes SpeI and EcoRI, and subsequently cloned into the NheI (compatible ends with SpeI) and EcoRI sites of the eukaryotic expression vector pIRESneo. After transformation of E.coli bacteria with the new constructs, single colonies were picked and the cloned sequences identified by DNA sequencing.

Several sequences in the thymus and spleen showed a 39 bp deletion of the exon11 at the junction to the exon 12. This cDNA species could be expressed as a 7-transmembrane receptor with a shortened last transmembrane domain (data not shown).

In the lung, one alternatively spliced cDNA clone was found where the initial 21 bp of the exon 12 was deleted. This splice variant would not lead to premature stop codons and could potentially produce a correctly folded 7-transmembrane protein with a shortened last transmembrane domain. Deletion mutant: mVPAC2 A T3 was identified where C>T at 1239, and T>C at 1117, and the stretch 1076 to 1098 (21 bp) was found deleted. This region belongs to the exon 12, same area as the hip and hop in the PACAP splice variant is mutated.

An additional clone was found to have an unspliced intron 11 (1095 insertion of intron 11), but was otherwise intact. Intron 11 with only 65 bps is at the limit of biologically

permissive intronic sequences. This sequence was detected in several sequences in the mouse lung cDNA. The small length of this intronic sequence is conserved in human and mouse (68bp in human). This conservation between human and mouse suggests its potential importance for the function of VPAC2.

Generally there are regulatory mechanisms present in cells that control splicing. The retention of this intron sequence in the processed mRNA would probably cause nuclear retention of the message, and even if this message could escape the nucleus, a premature stop codon in this message would rob the protein of its proposed signal transducing elements. All of the frequently detected splice variants showed alternative splicing of intron 11 at either the 5' or 3' end. Nevertheless, it was determined that the transfection of Jurkat cells with this cDNA (VPAC2-INRON11) could potentially give rise to the full length VPAC-2 protein (because introns are normally spliced, such that this sequence could be removed during expression). The full length VPAC-2 cDNA (which had one silent mutation in the coding region) was cloned on the assumption that splice-variants could modify the immunoregulatory contributions of the VIP-VPAC2 axis. The identification of splice variants in murine tissues suggested that they could give rise to expression of novel receptors with unique biological activity. To further investigate the biological relevance of these isoforms the cDNA products were subcloned into the Jurkat T cell line. The VPAC2-INRON11 (as introns are normally spliced), and the full length cDNA VPAC2 (with 21 bp deletion of exon 12) were selected for more intensive functional analysis.

#### **4.2 Stable mVPAC human Jurkat T cell transfectants**

Then we set out to generate T cell line that express mouse VPAC1R and VPAC2R. For this purpose we chose a human leukemic Jurkat T cell line that is CD4(+), and produces significant amounts of IL-2. One of the additional reasons for this selection was based on the publication from Qian et al, where VPACR2 was identified primarily in T cells (from small intestine). Further studies on purified subpopulations of T lymphocytes have indicated the existence of VPAC2R in CD8(+) T cells, but not CD4(+) and CD4CD8 double negative T cells, although all these three subpopulations displayed VPAC1R (Qian, BF 2001).

The human Jurkat T cell line was transfected with a vector containing cDNA for the intron 11 (VPAC2-i11). A Kozak consensus sequences necessary for efficient ribosomal binding was built into the 5' end of the cDNAs as the endogenous sequence was lost in the subcloning. For this purpose the relevant primers were generated (Kozak, 1987).

The cDNAs were then subcloned into a pIRES (internal ribosome entry site) vector that allows bicistronic expression of the desired clone. Stable Jurkat transfectants of mVPAC1 and pIRES (as control) were generated. We were not surprised to find that the production of a stable transfectant cell line with the full length cDNA of VPAC2 was unsuccessful. Sequencing indicated that the inserted intron in this sequence is precisely spliced, but included an additional event that was not detect in the other clones: a stretch of 78 bp (amino acid 115-138, 26 amino acids) from the first extracellular domain into the parts of the first transmembrane domain (126-159) is deleted in these cells. The missing sequence is equivalent to almost the whole exon 5, except 3 nucleotides at the beginning that are AGT>AGA, which is S>R exchange at the beginning. Such a transcript would be transcribed, although a region of the extracellular and first transmembrane of the receptor is missing. This region may be important for ligand binding. None of the conserved cysteine residues are deleted. The amino terminus and second and third extracellular loops posses five cysteine residues that are highly conserved among VPAC1/2, PACAP, secretin and glugacon receptors that may form disulfide bonds necessary for agonist binding conformation as shown for rhodopsin (Karnik et al., 1988). We used this mouse VPAC2 transfectants (mVPAC2<sup>del\_78</sup>) as working cell line.

Structures	
DNA sequences Wild-type  Deletion mutant 78bp	<pre> 390cgaggatgag a gtaag atct cgttttatatatttggggaag gccatttata ccttgggcta cagtgtttct ctgatgtctc tt acaacagg aagcataatt atctgcctct500  390cgaggatgag ..... aagcataatt atctgcctct500 </pre>
Amino acid sequences Wild-type  Deletion mutant 78bp	<pre> 100FPDFIDACGYNDPEDESKISFYILVKAIYTLGYSVLSLTTGSIICLFRRKLHCTRNYI160  100FPDFIDACGYNDPEDE.....SIICLFRRKLHCTRNYI160 </pre>

**Table 7: Structures of mVPAC2 GPCRs and level of mRNA expression in Jurkat T cell transfectants**

Protein prediction analysis (hydropathy analysis) results indicated that a protein generated from this altered transcript could be expressed as a seven transmembrane protein. At present the significance of these, possibly posttranscriptional modified mRNAs are not understood. However, AT rich sequences within the coding sequence as well as two ATTTA pentamers suggest that the VPAC2 sequence is an unstable mRNA and therefore subject to posttranscriptional modifications such as mRNA editing and mRNA splicing.

The binding of this protein to VIP was then evaluated in more detail. The protein could in theory act in its function as an adenylate cyclase activator, with or without VIP, or potentially with another molecule as a ligand. In one case, we found a pattern of alternative splicing of VPAC2 that would delete the entire last cytoplasmic domain. If this protein was translated, it could in theory act as a decoy VIP receptor with no signalling function.

VPAC2 has several AUUUA elements. These are found in the mouse as well as in the human system, within the untranslated 3' region as well as within the coding region.



AUUUA elements are known to destabilize the mRNA, so it was anticipated that making stable transfectants for VPAC-2 in Jurkats could prove difficult (Malter, 1989).

A Jurkat mVPAC2<sup>del\_78</sup>, mVPAC1 stable transfectant and a pIRES control cell line were created. Using RT PCR and subsequent sequence analysis, endogenous hVPAC1 and hVPAC2 could not be detected in the Jurkat cells before transfection by real-time PCR (data not shown). Nevertheless, the subsequent binding and cAMP studies suggest a low level of endogenous hVPAC expression in Jurkat cells (see results below).

### **4.3 VIP Competitive Binding Assay of Jurkat T cell transfectants**

Binding assays can provide information about the affinity of sites as well as the total number of binding sites per cell. Binding assays involve a timed incubation with the radioligand and the cells expressing the receptor of interest at optimized temperature and conditions. Binding is allowed to proceed until it reaches equilibrium. Termination of the assay separates free from bound and the radioactivity remaining is counted.

Competitive binding studies using live cells and <sup>125</sup>I-labeled VIP as a radioligand were performed with all three transfectant cell lines. We demonstrated that receptors with a Kd of approximately 1-2 nM were present on mVPAC2<sup>del\_78</sup> transfected cells. The receptor density was calculated to be about 1000 receptors per cell. In contrast, we found 5 times higher receptor density of mVPAC1 transfected cells, the Kd value for mVPAC1 was calculated to be around 2 nM. There was no specific binding seen in the control pIRES cells. Data analysis was done using the Easybound software. The curves were drawn by the software and cannot be manipulated. Further experiments tested whether the mVPAC receptors on the Jurkat T cells were functional.

A.)

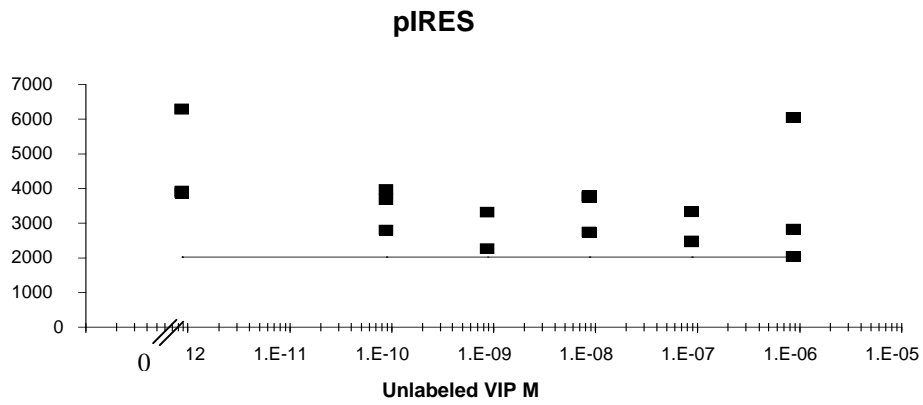

B.)

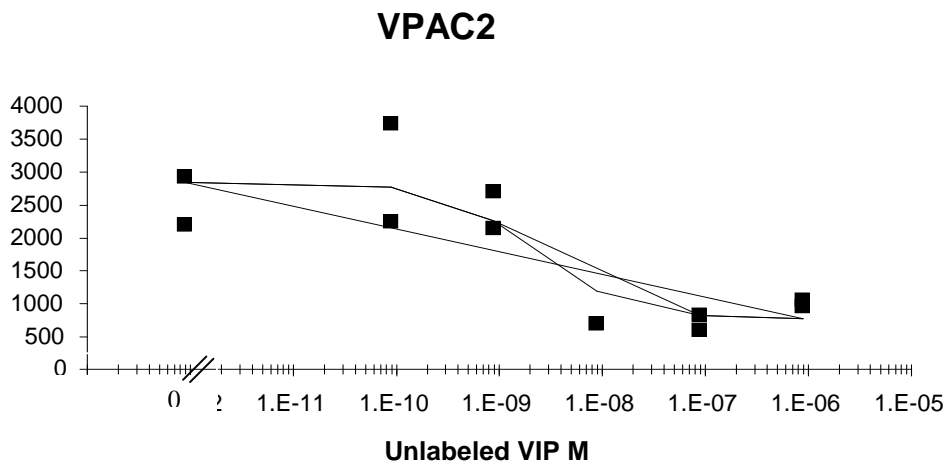

C.)

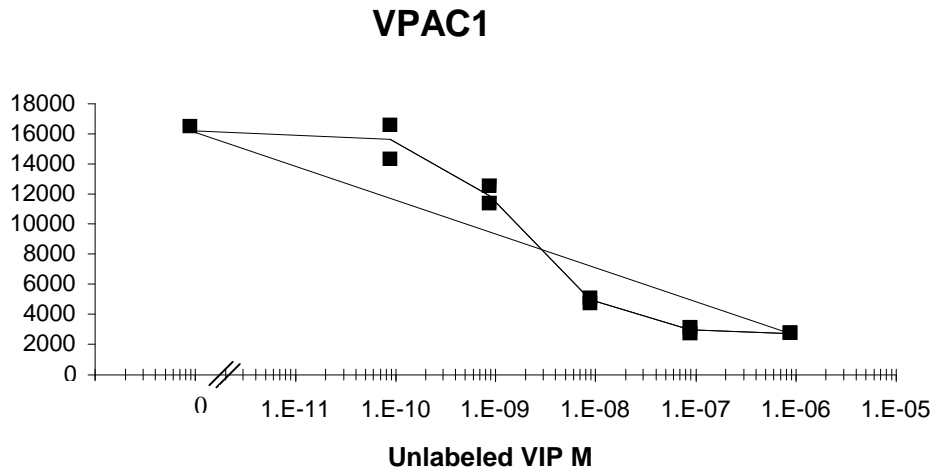

**Figure 9: Competitive binding assays.** Using A.) pIRES, B.) mVPAC2<sup>del-78</sup>, and C.) mVPAC1 transfected Jurkat live cells binding assays were performed at room temperature. Shown data are representative of at least 3 independent experiments. Data analysis was done using the Easybound software. The curves were drawn by the software and cannot be manipulated.

#### 4.4 cAMP assay of human Jurkat T cell transfectants

The intracellular signalling pathways mediating the actions of VIP and pituitary adenylate cyclase-activating polypeptide (PACAP) were investigated in these stable transfectant cell lines. A cAMP ELISA assay as described in the method section was applied. Two different stimuli at different concentrations in the bottom of the transwell chamber VIP and PACAP 38 were used. PACAP 38 is a member of the vasointestinal polypeptide/secretin/glucagon family.

In accordance with the binding studies, ligand-dependant cAMP accumulation in mVPAC1 was observed, and to a lesser extent in mVPAC2<sup>del\_78</sup> stable Jurkat cells but not in control cells (Fig.10). A minimal increase in cAMP in control untransfected cells indicated that the surface expression of the endogenous hVPAC1 and hVPAC2 was very low. VIP was found to be as effective as PACAP-38 in inducing a cAMP response.

A.)

### VIP Stimulated cAMP Accumulation in Jurkat Cells

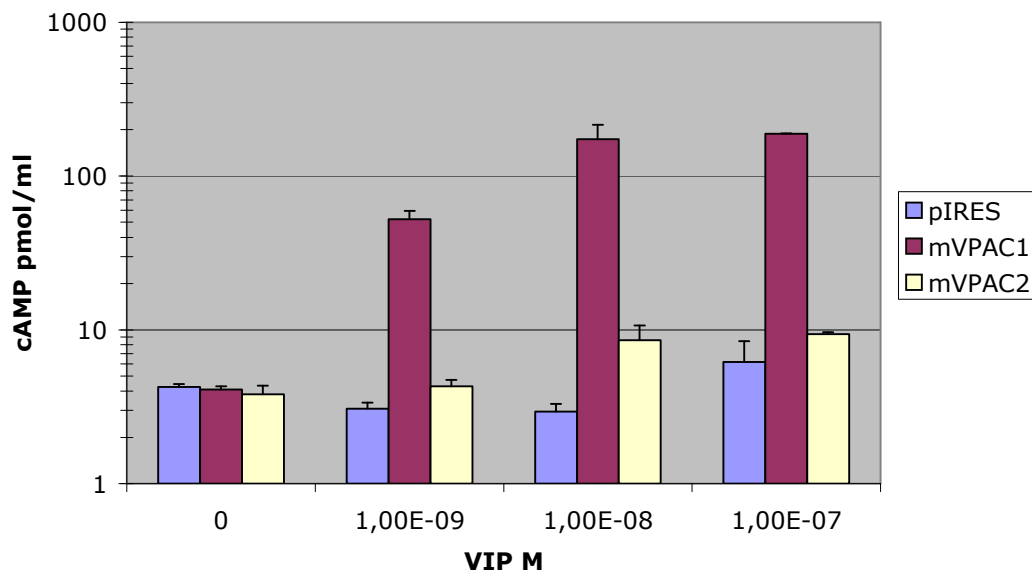

B.)

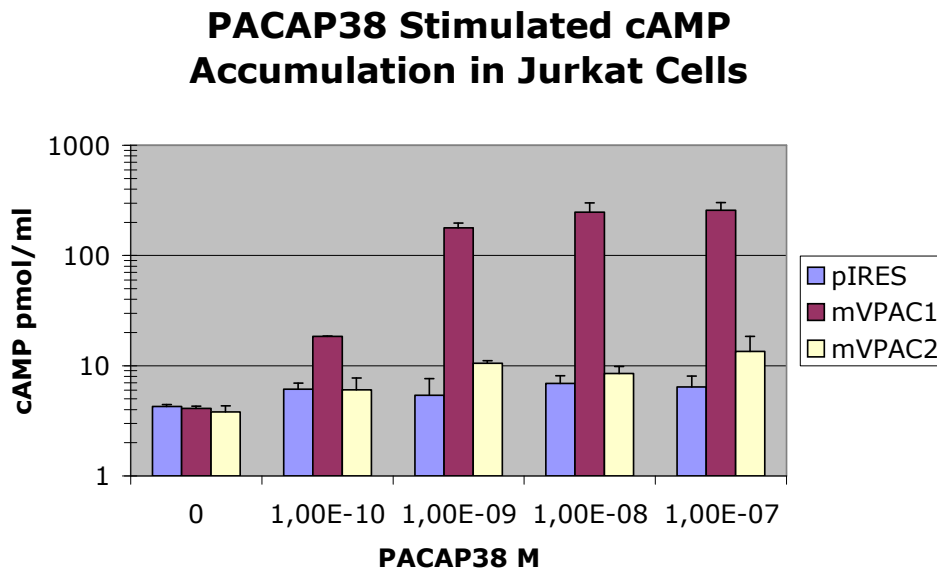

**Figure 10 A.) and B.): cAMP assay with human Jurkat transfectants.** The transfectants were treated with various amounts of VIP (A) or PACAP38 (B) (concentration range  $10^{-7}$  to  $10^{-10}$  M). cAMPi was measured using an ELISA system purchased from R&D Systems. Each column and bar depicts the mean  $\pm$  S.D. of the result of three studies conducted in duplicate.

#### 4.5 Starvation survival studies of human Jurkat transfectant

Jurkat transfectants were cultured in their exponential growth phase in fresh media with various fetal bovine serum (FBS) concentrations and the kinetics of their density was studied. The cell density at the beginning was  $10^6$  cells/ml. After 1 day of culture in 0% FBS there was a decrease in the cell density of all transfectants. The most dramatic decrease was seen in mVPAC2<sup>del\_78</sup> transfectants, which may indicate that these cells have become more dependent on certain growth factors. Such growth factor dependency appeared to be underlined by the increased proliferation of mVPAC2<sup>del\_78</sup> transfectants in 10% FBS. On the other hand, the mVPAC1 cells appear to have become more independent of growth factors, which is reflected in their increased density compared with the pIRES transfected and mVPAC2<sup>del\_78</sup> cells in all studied FBS concentrations.

When grown in media containing FBS no further increase in cell density of pIRES transfectants was seen after 1 day, indicating that inhibitory factors may be present in FBS or produced by the pIRES transfectants that inhibit the proliferation. By day 2 and 4 the proliferation of pIRES cells had increased, which may suggest the degradation of inhibitory factors or the production of Jurkat-specific growth factors.

In conclusion it appears that mVPAC2<sup>del\_78</sup> was able to confer growth factor dependency, whereas mVPAC1 conferred growth factor independency to the Jurkat cells.

**Survival of VPAC Stable Transfectants, Day 1**

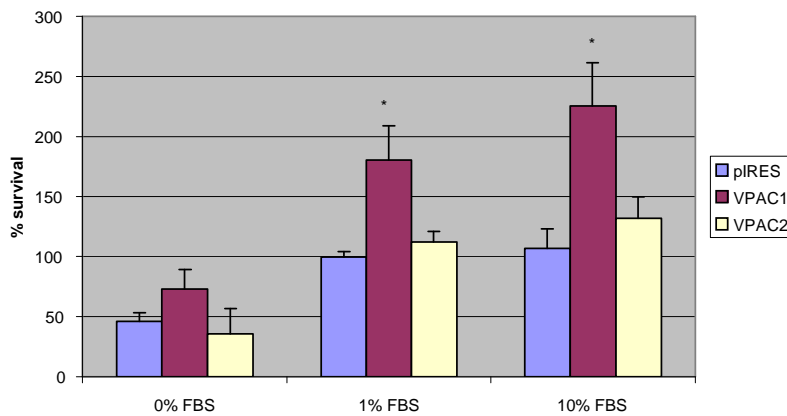

**Survival of VPAC Stable Transfectants, Day 2**

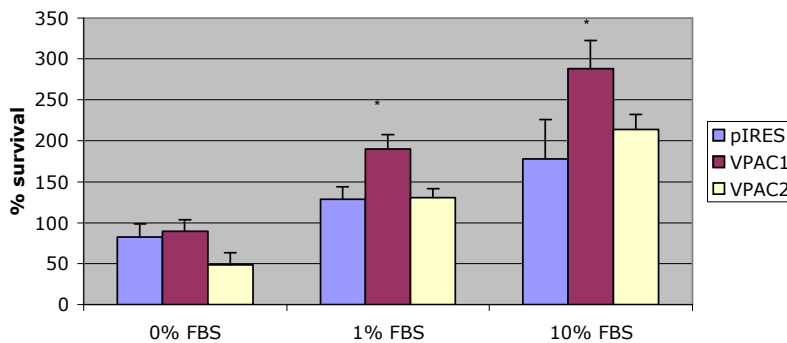

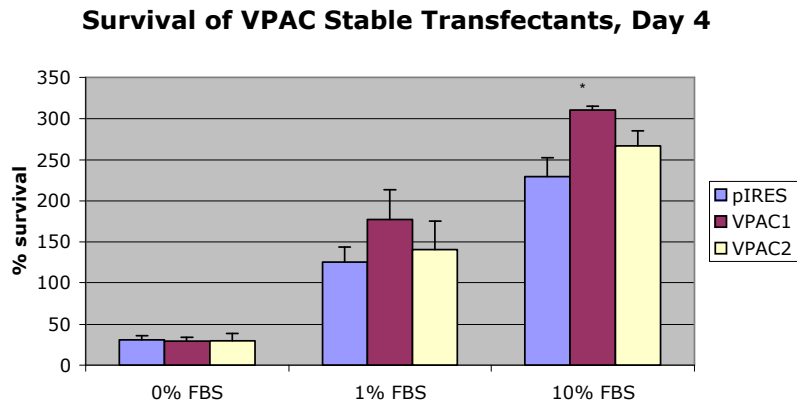

**Figure 11: Cellular densities of Jurkat transfectants at different fetal bovine serum (FBS) concentrations and different days 1, 2 and 4.** Jurkat transfectants were cultured in fresh media in triplicates and live cell numbers were determined by trypan blue exclusion. ( $p < 0.05$ )

#### 4.6 Flow cytometry apoptosis study of human Jurkat T cell transfectants

Dead cells that have a disrupted cellular membrane incorporate 7AAD as detected by flow cytometry (FACS). Jurkat transfectants were incubated at  $10^6$  cells/ml density in fresh media containing 10% FBS overnight and subsequently triplicates of cultured cells were stained with 7AAD and analyzed in FACS.

The ratio of alive/dead cells was approximately twice that in mVPAC1 and mVPAC2<sup>del\_78</sup> transfectants as compared to pIRES control transfectants. This finding may indicate that the lower cell numbers in the previous experiment in pIRES cells might be at least to some extent due to increased cellular death. The observation that mVPAC2<sup>del\_78</sup> cells show even a slightly higher alive/dead ratio compared with mVPAC1 transfectants, but at the same time exhibit as shown in the previous section a lower cell density, indicates that mVPAC2<sup>del\_78</sup> transfectants proliferate less and undergo apoptosis or necrosis also less than the other studied cell types.

### Proportion of Alive/Dead Cell Ratio in Unstimulated VPAC1, VPAC2, and Mock Transfected Jurkat Cells

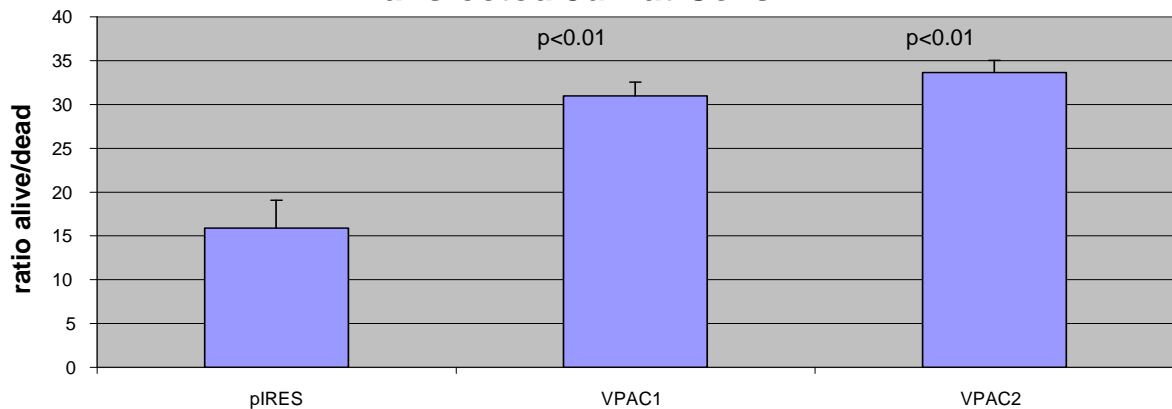

**Figure 12: Flow cytometry.** The ratio of alive/dead cells was measured by 7AAD staining and subsequent FACS analysis. At their logarithmic growth phases, the mVPAC1 and mVPAC2<sup>del\_78</sup> transfectants show a higher ratio of alive/dead cell number.

#### 4.7 Migration study of human Jurkat T cell transfectants

The chemotactic effects of VIP and human stromal derived factor-1 (hSDF-1) as positive controls were then studied on these human Jurkat T cell transfectants using a chamber transwell system. Previous studies had demonstrated that lymphocytes were able to migrate in the Boyden chamber assay when the polycarbonate filters were coated with matrix protein such as fibronectin (Kelvin et al., 1993). In this migration study, VIP (in different concentrations - data not shown) caused a significant reduction of migration in all three transfectant cell lines which reached significance in both mVPAC1 and mVPAC2<sup>del\_78</sup> Jurkat T cells, but not in the untransfected pIRES control cells. If VIP and hSDF-1 were added together as stimuli, migration decreased significantly in both the



mVPAC1 and pIRES controls, but to a lesser degree in mVPAC2<sup>del\_78</sup>. If hSDF-1 was added alone, which is known to be a T cell migration stimulus, the best migration response from the mVAPC1 transfected cells, and the least response from the mVPAC2<sup>del\_78</sup> transfectants was seen.

If no stimulus was added at all, a random cell migration, or chemokinesis response was seen in all three transfectant cell lines. Thus, the cells showed altered migration profiles.

### Inhibition of Migration by VIP

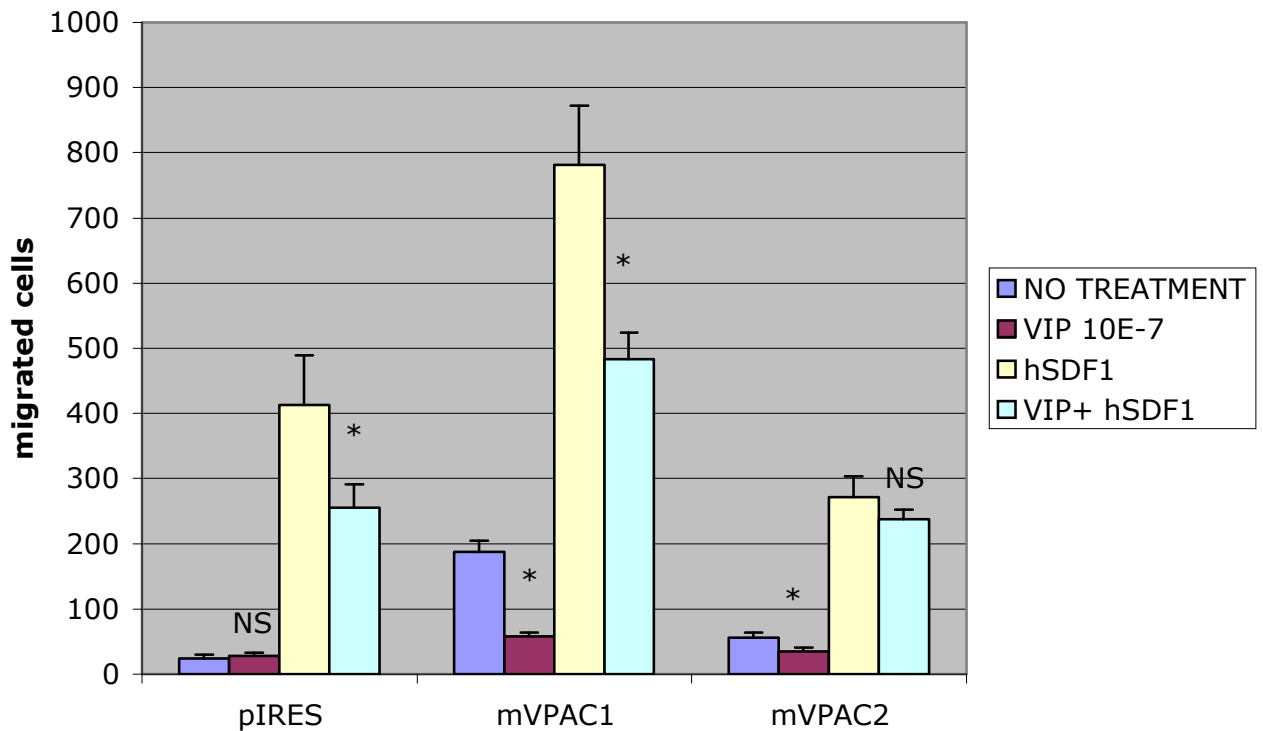

**Figure 13: Migration assay.** VIP causes a significant reduction of Jurkat cell migration in mVPAC1 and mVPAC2<sup>del\_78</sup> transfected cells but not in untransfected control cells (pIRES). VIP treatment of hSDF-1 treated cells significantly inhibits migration of pIRES and mVPAC1 transfected cells but not of mVPAC2<sup>del\_78</sup> transfected cells.

## 5. Discussion

At the time of the proposed studies, there had been no reports of splice variants of the mVPAC2 receptor. The receptor is thought to help control the T cell response in various settings. It was hypothesized that splice-variants of VPAC2 receptor may exist in murine tissues that act as an additional level of control to regulate function.

These PCR based experiments have shown that a variant of mouse VPAC2 is present in mouse lung tissue. The resultant sequence showed a deletion of 26 amino acids from the first extracellular domain of the first transmembrane domain. The missing sequence is equivalent to, and appears to correspond to, virtually the entire fifth exon. Based on sequence analysis the resulting transcript could be translated, although a region of the extracellular and first transmembrane of the receptor would be missing. Functionally, the first transmembrane region is thought to be important for ligand binding and thus may be important in receptor mediated effects. To this end, signaling and migration studies were designed to characterize these issues more in detail using mouse VPAC1 and VPAC2 GPCR stable transfectants in human Jurkat T cells. After several weeks of Geneticin-selection of Jurkat T cells transfected with pIRESneo3-VPAC plasmids, stable transfectants were generated where the mRNAs encoding mouse VPAC1 and the mouse VPAC2 deletion-mutant were constitutively expressed.

The presence of specific binding sites (transgenic expressed receptors) was demonstrated in the two cloned mouse VPAC receptor transfectant T cell lines using  $^{125}\text{I}$ -VIP as a radioligand. The receptor density of the mVPAC1 transfectant cells was five times higher than for the mVPAC2<sup>del-78</sup> transfectant cells. The mVPAC1 Jurkat cells bound VIP with high affinity and mVPAC2<sup>del-78</sup> with lower affinity. The respective mean Kd value of mVPAC1 was 2nM and of mVPAC2<sup>del-78</sup> was 1-2 nM. There was no binding of the radioligand to untransfected Jurkat cells. These results demonstrated that any differences in signaling and transduction of functions between the two forms of mouse VPAC receptor could not be attributable to altered binding of VIP. Further experiments were applied to test whether the VPAC receptors on the Jurkat T cells were functional. Alternative splicing is a process of mRNA editing which changes the molecular (like

ligand affinity or regulation of intracellular signalling) and pharmacological properties of a receptor by changing its structure.

### **Increase in cAMP**

The regulation of cAMP levels is critical for diverse biologic processes in all cell types and is a feature of signal transduction from multiple receptors, including T cell receptors. One of the principal signals transduced by VIP binding to VPAC1 and VPAC2 is a G $\alpha$ s-mediated increase in [cAMP]<sub>i</sub>. In these studies, a 10-fold increase in the [cAMP]<sub>i</sub> in mVPAC1 transfectants were elicited by VIP in a concentration-dependent relationship up to a maximal level similar to that attained by PACAP 38. The deletion-mutant mVPAC2<sup>del\_78</sup> transfectants showed a much lower rise in [cAMP]<sub>i</sub> at different concentrations of VIP and PACAP 38 added. Untransfected Jurkat T cells that express only very low levels of human native VPAC1 and VPAC2 showed a very low rise in [cAMP]<sub>i</sub>, which never exceeded 10-fold. While cAMP clearly mimics the effect of VIP on the transfectants, additional messenger pathways may also be involved. The cAMP signal is often integrated with that of other signals, particularly Ca<sup>2+</sup>, that also regulate the activity of ACs and phosphodiesterases (Zaccolo and Pozzan, 2003).

Studies on gene expression of VIP suggest a two way relationship between VIP and cAMP. VIP biosynthesis is promoted by higher cAMP levels, and thus the peptide is potentially capable of stimulating its own generation (Gozes and Brenneman, 1989).

GPCRs use different G $\alpha$ s dependent intracellular signaling pathways. One of the effects seen is an increase in cAMP, which was also examined in this thesis. The importance of these G signaling pathways in the context of VPAC receptors stimulation is not fully understood. Agonists for several GPCR's have been shown to increase the levels of immunosuppressive cyclic AMP in immune cells. VIP has been found to stimulate adenylate cyclase in membrane preparations from both cultured and peripheral blood lymphocytes (O'Dorisio et al., 1981). Other receptors associated with cAMP increase include prostaglandin E1 and E2 and the histamine receptors. These early studies suggested the potential role of cyclic AMP as an important second messenger in VIP action (Laburthe et al., 1994).

Every member of the group II family GPCR's identified to date mediate a robust increase in cellular cAMP levels, presumably via receptor coupling to the heterotrimeric G protein Gs (Laburthe et al., 1996). The likely retraction and distortion of this extracellular domain by deletion of the amino acid sequence would be expected to alter signalling and function. Transfectants expressing the deletion-mutant VPAC2 GPCRs at a level equal to that of mVPAC1 GPCRs control transfectants failed to manifest VIP-evoked increases in [cAMP]<sub>i</sub>.

Another published study using HEK 293 cells transiently transfected with rat VPAC1 showed an EC<sub>50</sub> for cAMP accumulation of 0.2 nM in response to VIP. In time-course experiments a rapid increase in cAMP accumulation was demonstrated that declined with a t<sub>1/2</sub> of 5 min, yielding a complete cessation of further cAMP accumulation after 10-15 min of agonist exposure. This dose dependent increase in cAMP was completely desensitized after 20 minutes (Shetzline et al., 2002).

Subtypes of a given receptor can differ markedly in their desensitization properties and this may be an important reason for the existence of receptor subtypes. After activation many ligand-gated ion channels enter a desensitized state in which neurotransmitter like VIP remains bound but the ion channel is closed. An important process in the desensitization of GPCRs is the phosphorylation of agonist occupied receptors, followed by receptor internalization and, finally, eventual recycling to the plasma membrane as a competent receptor (Ferguson et al., 1998).

Like most GPCRs, it has been demonstrated that hVPAC2 receptor is desensitized in response to VIP exposure. The receptor undergoes both agonist-induced phosphorylation and internalization and it is likely that both processes are involved in desensitization of the receptor (McDonald et al., 1998). Several different intracellular signaling pathways for VIP have been described (Pincus et al., 1990a). The cAMP pathway is an important pathway in T cell biology. Wang et al. studies indicate that VIP inhibits cytokine production in stimulated CD4<sup>+</sup> T cells through two separate mechanisms, which involve both cAMP-dependent and cAMP-independent transduction pathways (Wang et al., 1999).

VIP (1 $\mu$ M) elevates intracellular levels of cAMP four fold and causes secretion of BN-like peptides from SCLC cells (Moody and Perry, 1990). VIP and PACAP-38 are equipotent in stimulating cyclic AMP production at the VPAC<sub>2</sub> receptor (Lutz et al., 1993). In this cAMP assays the transfectants were treated with different VIP and PACAP-38 concentrations and we could see that VIP and PACAP-38 were equipotent in stimulating cAMP as described by Lutz et al. Interestingly, Ishihara and Zawilska saw a stronger action of PACAP-38 than of VIP. This may be explained in part by the different cell type model used (Ishihara et al., 1992; Zawilska et al., 2005).

It has been suggested that cAMP can serve as a second messenger mediating the long-term survival-promoting actions of VIP on sympathetic cultured neuroblasts (Pincus et al., 1990a). To better define the effect of cAMP on survival, the authors cultured their cells in the presence of VIP or an analogue of cAMP (CPT). This led to an increase in survival 6- and 10-fold respectively suggesting that cAMP may serve as a second messenger mediating the survival promoting actions of VIP on neuroblasts (Pincus et al., 1990a). These observations may help explain the apoptosis and starvation experiment results detailed in this thesis.

### **Starvation survival studies of Jurkat transfectants**

Survival studies performed as described in the method section showed that in contrast to the mVPAC1 transfectants, mVPAC2<sup>del<sub>78</sub></sup> transfectants and untransfected Jurkats need growth factor for their proliferation. MouseVPAC1 and mVPAC2<sup>del<sub>78</sub></sup> transfectants reached higher cell densities as compared to the untransfected cells. To what extent VPAC expression may inhibit contact inhibition of proliferation *in vivo* will require further investigation. The data suggest that VPAC-like receptors may also be important in maintaining cellular mass of the immune compartment.

The increased survival of mVPAC1 transfectants may also be associated with a decrease in the sensitivity of the cells to apoptosis. In the prostate cancer cell line PC-3 VIP and PACAP 27 were shown to modulate the expression levels of antiapoptotic and proapoptotic proteins in addition to inhibiting DNA fragmentation during apoptosis induced by serum withdrawal. This increased cell survival is thought to be exerted through VPAC1 (Gutierrez-Canas et al., 2003). Sumimoto described a mechanism that

could explain the survival effect exerted by G-protein-coupled receptor agonists, such as bombesin and endothelin-1. (Sumitomo et al., 2001) They observed that these neuropeptides stimulate ligand-independent activation of the IGF-1 receptor resulting in activation of the serine-threonin kinase Akt that mediates cell survival.

Cultured cerebellar granule cells undergo apoptosis within 48 hours in the absence of fetal calf serum (FCS). The addition of VIP, PACAP38 and PACAP27 dose dependently rescued cells from apoptosis, but only VIP was found to be effective at  $10^{-6}$  M (Canonico et al., 1996). Neuroprotective actions of cAMP in various cell types have been reported (Brenneman et al., 1985; Kaiser and Lipton, 1990; Rydell et al., 1988). VIP, acting by increasing cAMP, has a neurotrophic effect on electrically blocked retinal ganglion cells and may be an endogenous factor modulating normal cell death in the retina (Kaiser and Lipton, 1990).

VIP has been shown to prevent PC12 cell death during serum withdrawal. Cell viability was assessed with varying concentrations of VIP (Said and Dickman, 2000). VIP has also been characterized as a growth regulator for fetuses (Gressens et al., 1993; Waschek, 1995) and during embryonic brain development (Gozes et al., 1999).

The stimulation of protein kinase A, protein kinase C, and MAP kinase leads to activation by phosphorylation of the cyclic (c)AMP-response-element-binding protein (CREB). The latter step results in upregulation of anti-apoptotic bcl-2. We now have evidence supporting the importance of protein kinase A (PKA) in the protection afforded by VIP paraquat-induced injury. Lung edema was prevented by VIP, and PKA inhibitor H89 blocked the protection by VIP, but protein kinase C (PKC) inhibitor had little effect (Pakbaz et al., 1993).

The other components of this integrated view of survival-promoting pathways in the lung remain to be validated. VIP was found to increase the survival of neurons and prevents the neurotoxic effect of HIV (Pincus et al., 1990b). VIP protects mouse and human thymocytes treated with cytolytic dose of the prednisolone *in vitro* (Ernstrom et al., 1995).

### **Apoptosis study of human Jurkat T cell transfectants**

Apoptosis, or programmed cell death, is essential for normal tissue development and homeostasis, and also represents a critical mechanism of pathologic cell death (Fraser and Evan, 1996). Increases in cAMP may either initiate or inhibit apoptosis of lymphocytes depending on the specific circumstances (Goetzl et al., 1995a). Increasing evidence suggests that VIP also plays a role in cell survival in different systems. In fact, VIP has been shown to stimulate neuronal survival directly and indirectly via the glial cell release of neurotrophic factors (Brenneman et al., 1997). Largely as a result of research on neuronal cells, a hypothesis has been presented of the signal transduction pathways that promote cell survival through VIP (Walton and Dragunow, 2000).

In the experiments detailed here flow cytometry based assays were used to assess apoptosis of the mVPAC1 and mVPAC2<sup>del\_78</sup> transfectants. Both lines were found to undergo less apoptosis as compared to the control cells. In addition it was observed that the mVPAC2<sup>del\_78</sup> transfectants showed an even slightly higher alive/dead ratio as compared to mVPAC1 transfectants, but at the same time exhibit a lower cell density. This suggests that mVPAC2<sup>del\_78</sup> transfectants undergo less apoptosis than do the other two cell types. The observation that mVPAC2<sup>del\_78</sup> cells show a slightly higher alive/dead ratio as compared to the mVPAC1 transfectants, but at the same time exhibit, as shown in the previous section a lower cell density, suggests that mVPAC2<sup>del\_78</sup> transfectants proliferate less and undergo apoptosis or necrosis also less than the other studied cell types. Most of the published data did not show a decrease of apoptosis through VPAC2 receptor as seen in our experiments.

Prevention of apoptosis by VPAC1 and VPAC2 receptors has been shown by previous experiments. VIP and PACAP were found to prevent apoptosis through both mVPAC1 and mVPAC2 receptors in stimulated T cells as shown by Delgado (Delgado and Ganea, 2000). The effect of VIP, PACAP27 and PACAP38 (in a concentration range from  $10^{-13}$  to  $10^{-6}$  mol/l) on glucocorticoid induced apoptosis in vitro on thymocytes was studied. VIP and PACAPs were both found to inhibit apoptosis significantly, and increase the cell survival of thymocytes through stimulation of the VPAC1 receptor (Delgado et al.,

1996a). VIP and PACAP was also shown to prevent apoptosis in stimulated T cells through both mVPAC1 and mVPAC2 receptors (Delgado and Ganea, 2000).

VIP has shown to stimulate neuronal survival directly and indirectly via glial cell release of neurotrophic factors (Brenneman et al., 1997). Here the Jurkat cells were not activated. Indeed, the Jurkat cell line represents a late thymic early peripheral blood T cell phenotype.

Exogenously added VIP has also been shown to prevent apoptosis of primary cultures of mouse cerebellar granule cells under nondepolarizing conditions, the effect was mediated specifically through the VPAC1 receptor (Fukuchi et al., 2004).

### **Effects on Migration**

VIP caused significant inhibition of chemotactic migration in both mVPAC1 and mVPAC2<sup>del\_78</sup> Jurkat T cells but not in control cells. It is possible that the endogenous hVPAC1 is not expressed at high enough levels, although we were able to amplify and sequence the full-length transcript in control Jurkat cells (we could not detect the full-length hVPAC2 in Jurkat cells). The relative non-responsiveness of mVPAC2<sup>del\_78</sup> transfectants to VIP may be due in part to transcript modification or to its distinct biologic activity. When the chemokine hSDF-1 was used alone (which is known to be a T cell migration stimulus over the CXCR4 receptor) the best migration response was seen from the mVAPC1 transfected cells. If both VIP and hSDF-1 were added together as stimulus, the migration was found to decrease significantly in both mVPAC1 and control cells, but to a lesser degree in mVPAC2<sup>del\_78</sup> suggesting a functional cross desensitization by the two different chemotactic signals and confirm that VIP can act as a chemotactic inhibitor in our model.

In migration assays, the mVPAC1 and mVPAC2<sup>del\_78</sup> transfectants showed a distinct behavior that was not dependent on stimulation with the known ligands. Under the conditions chosen for the migration assays there should be no known VPAC ligands present in the media. Nevertheless, mVPAC1 and mVPAC2<sup>del\_78</sup> transfectants appeared to show a greater ability to migrate through a collagen coated synthetic membrane with a pore size of 5 micrometers. In addition, their response to the S1P stimulus appeared more pronounced when compared with control cells. These data may indicate that the



availability of the classical ligands may not be obligate for biologic activity of the VPAC receptors.

Moore has studied the effect of VIP on the passage of cells out of popliteal lymph nodes. In accordance to our results, his results also suggested that VIP may inhibit egress of small lymphocytes (Moore, 1984).

In contrast to what was described by Dunzendorfer who demonstrated that VPAC1 receptor was responsible of migration of human eosinophils, and could show a clear migration response induced by VIP, we could not see this migration response in our Jurkat T cell transfectants. Thus different cell types might show a different migration response induced by VIP (Dunzendorfer et al., 1998).

VIP is a known immunosuppressive neurotransmitter. Grimm also showed that VIP could inhibit the function of chemokine receptors on human monocytes and T-lymphocytes leading to impaired chemotaxis and calcium flux in the response to the cognate chemokine ligands CXCL12, CCL3, CCL4 and CCL5. This was mediated through VPAC1 receptor and was not caused by chemokine receptor internalization. Chemokines are key mediators of leukocytes chemotaxis to inflammatory sites in for example rheumatoid arthritis (Grimm et al., 2003).

Different VIP concentration were assessed in a dose response analysis (data not shown) Taub had shown that lymphocytes optimally respond at  $10^{-8}$  to  $10^{-9}$  M, displaying no significant migration at concentrations less than  $10^{-11}$  M or greater than  $10^{-6}$  M (Taub et al., 1993). One potential mechanism that could explain these results is that homologous desensitization of the VPAC receptors by the ligand results in rapid receptor internalization from the cell surface. Inhibition of receptor function caused by binding of ligands to different receptors (heterologous desensitization) usually results from activation of kinases such as protein kinase C (Ali et al., 1993).

The homing of mouse lymphocytes to mesenteric lymph nodes and Peyers patch of recipient mice was inhibited by *ex vivo* treatment of T cells with VIP, is associated with the inhibition of VIP receptor expression (Ottaway, 1987). So in this model, the VPAC receptor expression may have also been inhibited as explained by the lack of migration response.

Other studies have shown that VIP has no effect on stimulated T cells, so in some way the Jurkat T cells transfectants have been stimulated and the levels of receptor expression went down in our study. In T cells, cAMP-dependent protein kinase type I co localizes with the T cell receptor-CD3 complex (TCR/CD3) and inhibits T cell function (Skalhegg et al., 1994).

Other publications have shown that VIP has potent chemotactic effects at concentrations between  $10^{-8}$  and  $10^{-9}$  M on human T lymphocytes and monocytes (Johnston et al., 1994). VIP is even as potent as chemokines RANTES and MIP-1 $\alpha$ , but showing a reduced response at higher concentration (Wang et al., 1993). If the neuropeptide VIP is at too high a concentration, the T cells may become desensitized, similar to the response observed with other chemotactic ligands (Samanta et al., 1990). Previous studies, have demonstrated that VIP treatment can alter murine T cell homing (Lopez-Gonzalez et al., 1992).

#### **Limitation of the studies:**

As a critical issue I must address the generally low expression level of human VPAC2 receptor and human VPAC1 receptor in the Jurkat T cells and the potential influence of this on the presented results. The mouse lung expresses high amounts of VPAC2 receptors, presumably located in the epithelium; the human lung expresses predominantly VPAC1 receptors, although VPAC2 mRNA was also identified in one study (Harmar, 2003). Further investigation needs to identify species differences in the expression of the VPAC2 receptor deletion variants and to locate VPAC2 receptor mRNA, which may not be translated into a functional protein with equal efficiency in all tissues. It remains to be seen whether the mVPAC2<sup>del\_78</sup> receptor splice variant is able to couple to the IP3/[Ca<sup>2+</sup>]<sub>i</sub> pathway. It was previously shown that VAPC1 and VPAC2 receptor are also able to couple IP3/[Ca<sup>2+</sup>]<sub>i</sub> pathway (Langer et al., 2001).

During the cAMP experiments forskolin was not used. Forskolin is a VPAC2 selective agonist or VPAC1-selective agonist, and serves as a positive control. It is known to increase [cAMP]<sub>i</sub>. Such experiments were previously described (Grininger et al., 2004), thus I should have set up additional experiments were I added a VPAC1 antagonist and

agonist Ro 25-1553 to see if the inhibitory effect through VPAC1R could be prevented by pretreatment of the antagonist as shown by Grimm (Grimm et al., 2003).

The polycarbonate filter assays used in these studies have several limitations. The main drawback of these filters is that the thickness of the 10 µm membrane which does not allow any assessment of effects of absolute concentration compared to gradients (Wilkinson, 1996).

### **Conclusions**

The important questions that remain to be elucidated about the deletion-variant mVPAC2<sup>del\_78</sup> GPCR include the mechanism of its generation, its cell and tissue distribution, determinants controlling the regulation of its expression during development and after cellular activation, and its natural functional role in immunity and other physiological, pathophysiological activities affected by the VIP-VPAC2 GPCR axis. For example, what can be learned about its coupling to signal transduction pathways leading to differences in the level of activation of adenylate cyclase and phospholipase C?

Synthetic VIP receptor antagonists inhibit the proliferation and potentiate the ability of chemotherapeutic agents to cause apoptosis of lung and breast cancer cells. VIP-chemotherapeutic conjugates have been synthesized which bind to VPAC1 receptors and are internalized, resulting in the killing of lung and breast cancer cells. These results suggest that VPAC receptors may be molecular targets for diagnosis, prevention and treatment of breast cancer as well as lung cancer (Moody and Gozes, 2007). **One could also speculate that** VIP-stimulated T cells can signal to other T cells as neurons through soluble factors such as chemokines that regulate than T cell activity.

## 6. Literature

- Adamou, J.E., Aiyar, N., Van Horn, S., and Elshourbagy, N.A. (1995). Cloning and functional characterization of the human vasoactive intestinal peptide (VIP)-2 receptor. *Biochem Biophys Res Commun* 209, 385-392.
- Ali, H., Richardson, R.M., Tomhave, E.D., Didsbury, J.R., and Snyderman, R. (1993). Differences in phosphorylation of formylpeptide and C5a chemoattractant receptors correlate with differences in desensitization. *J Biol Chem* 268, 24247-24254.
- Arimura, A. (1992). Pituitary adenylate cyclase activating polypeptide (PACAP): discovery and current status of research. *Regul Pept* 37, 287-303.
- Barbezat, G.O., and Grossman, M.I. (1971). Intestinal secretion: stimulation by peptides. *Science* 174, 422-424.
- Boudard, F., and Bastide, M. (1991). Inhibition of mouse T-cell proliferation by CGRP and VIP: effects of these neuropeptides on IL-2 production and cAMP synthesis. *J Neurosci Res* 29, 29-41.
- Brenneman, D.E., Fitzgerald, S., and Litzinger, M.J. (1985). Neuronal survival during electrical blockade is increased by 8-bromo cyclic adenosine 3',5' monophosphate. *J Pharmacol Exp Ther* 233, 402-408.
- Brenneman, D.E., Phillips, T.M., Festoff, B.W., and Gozes, I. (1997). Identity of neurotrophic molecules released from astroglia by vasoactive intestinal peptide. *Ann N Y Acad Sci* 814, 167-173.
- Brink, C.B., Harvey, B.H., Bodenstein, J., Venter, D.P., and Oliver, D.W. (2004). Recent advances in drug action and therapeutics: relevance of novel concepts in G-protein-coupled receptor and signal transduction pharmacology. *Br J Clin Pharmacol* 57, 373-387.
- Bunnett, N.W., Reeve, J.R., Jr., Dimaline, R., Shively, J.E., Hawke, D., and Walsh, J.H. (1984). The isolation and sequence analysis of vasoactive intestinal peptide from a ganglioneuroblastoma. *J Clin Endocrinol Metab* 59, 1133-1137.
- Cagampang, F.R., Sheward, W.J., Harmar, A.J., Piggins, H.D., and Coen, C.W. (1998). Circadian changes in the expression of vasoactive intestinal peptide 2 receptor mRNA in the rat suprachiasmatic nuclei. *Brain Res Mol Brain Res* 54, 108-112.
- Canonica, P.L., Copani, A., D'Agata, V., Musco, S., Petralia, S., Travali, S., Stivala, F., and Cavallaro, S. (1996). Activation of pituitary adenylate cyclase-activating polypeptide receptors prevents apoptotic cell death in cultured cerebellar granule cells. *Ann N Y Acad Sci* 805, 470-472.
- Couvineau, A., Rouyer-Fessard, C., Darmoul, D., Maoret, J.J., Carrero, I., Ogier-Denis, E., and Laburthe, M. (1994). Human intestinal VIP receptor: cloning and functional expression of two cDNA encoding proteins with different N-terminal domains. *Biochem Biophys Res Commun* 200, 769-776.

- de la Fuente, M., Delgado, M., del Rio, M., Garrido, E., Leceta, J., Hernanz, A., and Gomariz, R.P. (1994). Vasoactive intestinal peptide modulation of adherence and mobility in rat peritoneal lymphocytes and macrophages. *Peptides* 15, 1157-1163.
- Delgado, M., Abad, C., Martinez, C., Leceta, J., and Gomariz, R.P. (2001). Vasoactive intestinal peptide prevents experimental arthritis by downregulating both autoimmune and inflammatory components of the disease. *Nat Med* 7, 563-568.
- Delgado, M., and Ganea, D. (2000). Vasoactive intestinal peptide and pituitary adenylate cyclase-activating polypeptide inhibit antigen-induced apoptosis of mature T lymphocytes by inhibiting Fas ligand expression. *J Immunol* 164, 1200-1210.
- Delgado, M., Garrido, E., Martinez, C., Leceta, J., and Gomariz, R.P. (1996a). Vasoactive intestinal peptide and pituitary adenylate cyclase-activating polypeptides (PACAP27) and PACAP38) protect CD4+CD8+ thymocytes from glucocorticoid-induced apoptosis. *Blood* 87, 5152-5161.
- Delgado, M., Martinez, C., Johnson, M.C., Gomariz, R.P., and Ganea, D. (1996b). Differential expression of vasoactive intestinal peptide receptors 1 and 2 (VIP-R1 and VIP-R2) mRNA in murine lymphocytes. *J Neuroimmunol* 68, 27-38.
- Delgado, M., Martinez, C., Leceta, J., Garrido, E., and Gomariz, R.P. (1996c). Differential VIP and VIP1 receptor gene expression in rat thymocyte subsets. *Peptides* 17, 803-807.
- Delgado, M., Munoz-Elias, E.J., Martinez, C., Gomariz, R.P., and Ganea, D. (1999). VIP and PACAP38 modulate cytokine and nitric oxide production in peritoneal macrophages and macrophage cell lines. *Ann N Y Acad Sci* 897, 401-414.
- DiCicco-Bloom, E., Deutsch, P.J., Maltzman, J., Zhang, J., Pintar, J.E., Zheng, J., Friedman, W.F., Zhou, X., and Zaremba, T. (2000). Autocrine expression and ontogenetic functions of the PACAP ligand/receptor system during sympathetic development. *Dev Biol* 219, 197-213.
- Dickinson, T., Mitchell, R., Robberecht, P., and Fleetwood-Walker, S.M. (1999). The role of VIP/PACAP receptor subtypes in spinal somatosensory processing in rats with an experimental peripheral mononeuropathy. *Neuropharmacology* 38, 167-180.
- Dimaline, R., Reeve, J.R., Jr., Shively, J.E., and Hawke, D. (1984). Isolation and characterization of rat vasoactive intestinal peptide. *Peptides* 5, 183-187.
- Domschke, S., Domschke, W., Bloom, S.R., Mitznegg, P., Mitchell, S.J., Lux, G., and Strunz, U. (1978). Vasoactive intestinal peptide in man: pharmacokinetics, metabolic and circulatory effects. *Gut* 19, 1049-1053.
- Dunzendorfer, S., Meierhofer, C., and Wiedermann, C.J. (1998). Signaling in neuropeptide-induced migration of human eosinophils. *J Leukoc Biol* 64, 828-834.
- Ernstrom, U., Gafvelin, G., and Mutt, V. (1995). Rescue of thymocytes from cell death by vasoactive intestinal peptide. *Regul Pept* 57, 99-104.
- Fahrenkrug, J. (1993). Transmitter role of vasoactive intestinal peptide. *Pharmacol Toxicol* 72, 354-363.

- Ferguson, S.S., Zhang, J., Barak, L.S., and Caron, M.G. (1998). Molecular mechanisms of G protein-coupled receptor desensitization and resensitization. *Life Sci* 62, 1561-1565.
- Foord, S.M., and Marshall, F.H. (1999). RAMPs: accessory proteins for seven transmembrane domain receptors. *Trends Pharmacol Sci* 20, 184-187.
- Fraser, A., and Evan, G. (1996). A license to kill. *Cell* 85, 781-784.
- Fukuchi, M., Sakuragawa, S., Tabuchi, A., and Tsuda, M. (2004). Calcium signal-mediated expression of the vasoactive intestinal polypeptide gene and its small contribution to activity-dependent survival of mouse cerebellar granule cells. *J Neurosci Res* 77, 26-34.
- Ganea, D. (1996). Regulatory effects of vasoactive intestinal peptide on cytokine production in central and peripheral lymphoid organs. *Adv Neuroimmunol* 6, 61-74.
- Gespach, C., Bawab, W., de Cremoux, P., and Calvo, F. (1988). Pharmacology, molecular identification and functional characteristics of vasoactive intestinal peptide receptors in human breast cancer cells. *Cancer Res* 48, 5079-5083.
- Goetzl, E.J., An, S., and Zeng, L. (1995a). Specific suppression by prostaglandin E2 of activation-induced apoptosis of human CD4+CD8+ T lymphoblasts. *J Immunol* 154, 1041-1047.
- Goetzl, E.J., Voice, J.K., Shen, S., Dorsam, G., Kong, Y., West, K.M., Morrison, C.F., and Harmar, A.J. (2001). Enhanced delayed-type hypersensitivity and diminished immediate-type hypersensitivity in mice lacking the inducible VPAC(2) receptor for vasoactive intestinal peptide. *Proc Natl Acad Sci U S A* 98, 13854-13859.
- Goetzl, E.J., Xia, M., Ingram, D.A., Kishiyama, J.L., Kaltreider, H.B., Byrd, P.K., Ichikawa, S., and Sreedharan, S.P. (1995b). Neuropeptide signaling of lymphocytes in immunological responses. *Int Arch Allergy Immunol* 107, 202-204.
- Gomariz, R.P., Martinez, C., Abad, C., Leceta, J., and Delgado, M. (2001). Immunology of VIP: a review and therapeutical perspectives. *Curr Pharm Des* 7, 89-111.
- Gourlet, P., Vandermeers, A., Vertongen, P., Rathe, J., De Neef, P., Cnudde, J., Waelbroeck, M., and Robberecht, P. (1997). Development of high affinity selective VIP1 receptor agonists. *Peptides* 18, 1539-1545.
- Gozes, I., Bassan, M., Zamostiano, R., Pinhasov, A., Davidson, A., Giladi, E., Perl, O., Glazner, G.W., and Brenneman, D.E. (1999). A novel signaling molecule for neuropeptide action: activity-dependent neuroprotective protein. *Ann N Y Acad Sci* 897, 125-135.
- Gozes, I., and Brenneman, D.E. (1989). VIP: molecular biology and neurobiological function. *Mol Neurobiol* 3, 201-236.
- Gressens, P., Hill, J.M., Gozes, I., Fridkin, M., and Brenneman, D.E. (1993). Growth factor function of vasoactive intestinal peptide in whole cultured mouse embryos. *Nature* 362, 155-158.
- Grimm, M.C., Newman, R., Hassim, Z., Cuan, N., Connor, S.J., Le, Y., Wang, J.M., Oppenheim, J.J., and Lloyd, A.R. (2003). Cutting edge: vasoactive intestinal peptide acts

as a potent suppressor of inflammation in vivo by trans-deactivating chemokine receptors. *J Immunol* 171, 4990-4994.

Grininger, C., Wang, W., Oskoui, K.B., Voice, J.K., and Goetzl, E.J. (2004). A natural variant type II G protein-coupled receptor for vasoactive intestinal peptide with altered function. *J Biol Chem* 279, 40259-40262.

Gutierrez-Canas, I., Rodriguez-Henche, N., Bolanos, O., Carmena, M.J., Prieto, J.C., and Juarranz, M.G. (2003). VIP and PACAP are autocrine factors that protect the androgen-independent prostate cancer cell line PC-3 from apoptosis induced by serum withdrawal. *Br J Pharmacol* 139, 1050-1058.

Gutkind, J.S. (1998). The pathways connecting G protein-coupled receptors to the nucleus through divergent mitogen-activated protein kinase cascades. *J Biol Chem* 273, 1839-1842.

Harmar, A.J. (2001). Family-B G-protein-coupled receptors. *Genome Biol* 2, REVIEWS3013.

Harmar, A.J. (2003). An essential role for peptidergic signalling in the control of circadian rhythms in the suprachiasmatic nuclei. *J Neuroendocrinol* 15, 335-338.

Harmar, A.J., Sheward, W.J., Morrison, C.F., Waser, B., Gugger, M., and Reubi, J.C. (2004). Distribution of the VPAC2 receptor in peripheral tissues of the mouse. *Endocrinology* 145, 1203-1210.

Hezareh, M., Journot, L., Bepoldin, L., Schlegel, W., and Rawlings, S.R. (1996). PACAP/VIP receptor subtypes, signal transducers, and effectors in pituitary cells. *Ann N Y Acad Sci* 805, 315-327; discussion 327-318.

Holst, B., and Schwartz, T.W. (2003). Molecular mechanism of agonism and inverse agonism in the melanocortin receptors: Zn(2+) as a structural and functional probe. *Ann N Y Acad Sci* 994, 1-11.

Ishihara, T., Shigemoto, R., Mori, K., Takahashi, K., and Nagata, S. (1992). Functional expression and tissue distribution of a novel receptor for vasoactive intestinal polypeptide. *Neuron* 8, 811-819.

Johnston, J.A., Taub, D.D., Lloyd, A.R., Conlon, K., Oppenheim, J.J., and Kevlin, D.J. (1994). Human T lymphocyte chemotaxis and adhesion induced by vasoactive intestinal peptide. *J Immunol* 153, 1762-1768.

Kaiser, P.K., and Lipton, S.A. (1990). VIP-mediated increase in cAMP prevents tetrodotoxin-induced retinal ganglion cell death in vitro. *Neuron* 5, 373-381.

Karnik, S.S., Sakmar, T.P., Chen, H.B., and Khorana, H.G. (1988). Cysteine residues 110 and 187 are essential for the formation of correct structure in bovine rhodopsin. *Proc Natl Acad Sci U S A* 85, 8459-8463.

Kawatani, M., Erdman, S.L., and de Groat, W.C. (1985). Vasoactive intestinal polypeptide and substance P in primary afferent pathways to the sacral spinal cord of the cat. *J Comp Neurol* 241, 327-347.

- Kelvin, D.J., Michiel, D.F., Johnston, J.A., Lloyd, A.R., Sprenger, H., Oppenheim, J.J., and Wang, J.M. (1993). Chemokines and serpentine: the molecular biology of chemokine receptors. *J Leukoc Biol* 54, 604-612.
- Knall, C., and Johnson, G.L. (1998). G-protein regulatory pathways: rocketing into the twenty-first century. *J Cell Biochem Suppl* 30-31, 137-146.
- Kolakowski, L.F., Jr. (1994). GCRDb: a G-protein-coupled receptor database. *Receptors Channels* 2, 1-7.
- Kozak, M. (1987). At least six nucleotides preceding the AUG initiator codon enhance translation in mammalian cells. *J Mol Biol* 196, 947-950.
- Kremer, J.M. (1999). Methotrexate and leflunomide: biochemical basis for combination therapy in the treatment of rheumatoid arthritis. *Semin Arthritis Rheum* 29, 14-26.
- Laburthe, M., Couvineau, A., Amiranoff, B., and Voisin, T. (1994). Receptors for gut regulatory peptides. *Baillieres Clin Endocrinol Metab* 8, 77-110.
- Laburthe, M., Couvineau, A., Gaudin, P., Maoret, J.J., Rouyer-Fessard, C., and Nicole, P. (1996). Receptors for VIP, PACAP, secretin, GRF, glucagon, GLP-1, and other members of their new family of G protein-linked receptors: structure-function relationship with special reference to the human VIP-1 receptor. *Ann N Y Acad Sci* 805, 94-109; discussion 110-101.
- Langer, I., Perret, J., Vertongen, P., Waelbroeck, M., and Robberecht, P. (2001). Vasoactive intestinal peptide (VIP) stimulates  $[Ca^{2+}]_i$  and cyclic AMP in CHO cells expressing Galphal6. *Cell Calcium* 30, 229-234.
- Langer, I., Vertongen, P., Perret, J., Waelbroeck, M., and Robberecht, P. (2002). A small sequence in the third intracellular loop of the VPAC(1) receptor is responsible for its efficient coupling to the calcium effector. *Mol Endocrinol* 16, 1089-1096.
- Lara-Marquez, M., O'Dorisio, M., O'Dorisio, T., Shah, M., and Karacay, B. (2001). Selective gene expression and activation-dependent regulation of vasoactive intestinal peptide receptor type 1 and type 2 in human T cells. *J Immunol* 166, 2522-2530.
- Lopez-Gonzalez, M.A., Calvo, J.R., Osuna, C., Rubio, A., and Guerrero, J.M. (1992). Melatonin potentiates cyclic AMP production stimulated by vasoactive intestinal peptide in human lymphocytes. *Neurosci Lett* 136, 150-152.
- Luis, J., Muller, J.M., Abadie, B., Martin, J.M., Marvaldi, J., and Pichon, J. (1986). Cycle of the vasoactive intestinal peptide and its binding site in a human adenocarcinoma cell line (HT 29). *Eur J Biochem* 156, 631-636.
- Lundberg, J.M., Hedlund, B., and Bartfai, T. (1982). Vasoactive intestinal polypeptide enhances muscarinic ligand binding in cat submandibular salivary gland. *Nature* 295, 147-149.
- Lutz, E.M., Shen, S., Mackay, M., West, K., and Harmar, A.J. (1999). Structure of the human VIPR2 gene for vasoactive intestinal peptide receptor type 2. *FEBS Lett* 458, 197-203.



- Lutz, E.M., Sheward, W.J., West, K.M., Morrow, J.A., Fink, G., and Harmar, A.J. (1993). The VIP2 receptor: molecular characterisation of a cDNA encoding a novel receptor for vasoactive intestinal peptide. *FEBS Lett* 334, 3-8.
- Mackay, M., Fantes, J., Scherer, S., Boyle, S., West, K., Tsui, L.C., Belloni, E., Lutz, E., Van Heyningen, V., and Harmar, A.J. (1996). Chromosomal localization in mouse and human of the vasoactive intestinal peptide receptor type 2 gene: a possible contributor to the holoprosencephaly 3 phenotype. *Genomics* 37, 345-353.
- MacKenzie, C.J., Lutz, E.M., Johnson, M.S., Robertson, D.N., Holland, P.J., and Mitchell, R. (2001). Mechanisms of phospholipase C activation by the vasoactive intestinal polypeptide/pituitary adenylate cyclase-activating polypeptide type 2 receptor. *Endocrinology* 142, 1209-1217.
- Magistretti, P.J., Morrison, J.H., Shoemaker, W.J., Sapin, V., and Bloom, F.E. (1981). Vasoactive intestinal polypeptide induces glycogenolysis in mouse cortical slices: a possible regulatory mechanism for the local control of energy metabolism. *Proc Natl Acad Sci U S A* 78, 6535-6539.
- Malter, J.S. (1989). Identification of an AUUUA-specific messenger RNA binding protein. *Science* 246, 664-666.
- McCulloch, D.A., MacKenzie, C.J., Johnson, M.S., Robertson, D.N., Holland, P.J., Ronaldson, E., Lutz, E.M., and Mitchell, R. (2002). Additional signals from VPAC/PAC family receptors. *Biochem Soc Trans* 30, 441-446.
- McDonald, T.P., Dinnis, D.M., Morrison, C.F., and Harmar, A.J. (1998). Desensitization of the human vasoactive intestinal peptide receptor (hVIP2/PACAP R): evidence for agonist-induced receptor phosphorylation and internalization. *Ann N Y Acad Sci* 865, 64-72.
- Misbin, R.I., Wolfe, M.M., Morris, P., Buynitzky, S.J., and McGuigan, J.E. (1982). Uptake of vasoactive intestinal peptide by rat liver. *Am J Physiol* 243, G103-111.
- Miyata, A., Arimura, A., Dahl, R.R., Minamino, N., Uehara, A., Jiang, L., Culler, M.D., and Coy, D.H. (1989). Isolation of a novel 38 residue-hypothalamic polypeptide which stimulates adenylate cyclase in pituitary cells. *Biochem Biophys Res Commun* 164, 567-574.
- Miyata, A., Jiang, L., Dahl, R.D., Kitada, C., Kubo, K., Fujino, M., Minamino, N., and Arimura, A. (1990). Isolation of a neuropeptide corresponding to the N-terminal 27 residues of the pituitary adenylate cyclase activating polypeptide with 38 residues (PACAP38). *Biochem Biophys Res Commun* 170, 643-648.
- Moody, T.W., and Gozes, I. (2007). Vasoactive intestinal peptide receptors: a molecular target in breast and lung cancer. *Curr Pharm Des* 13, 1099-1104.
- Moody, T.W., Walters, J., Casibang, M., Zia, F., and Gozes, Y. (2000). VPAC1 receptors and lung cancer. *Ann N Y Acad Sci* 921, 26-32.
- Moore, T.C. (1984). Modification of lymphocyte traffic by vasoactive neurotransmitter substances. *Immunology* 52, 511-518.

- Moore, T.C., Spruck, C.H., and Said, S.I. (1988). Depression of lymphocyte traffic in sheep by vasoactive intestinal peptide (VIP). *Immunology* 64, 475-478.
- Moreno, D., Gourlet, P., De Neef, P., Cnudde, J., Waelbroeck, M., and Robberecht, P. (2000). Development of selective agonists and antagonists for the human vasoactive intestinal polypeptide VPAC(2) receptor. *Peptides* 21, 1543-1549.
- Mutt, V., and Said, S.I. (1974). Structure of the porcine vasoactive intestinal octacosapeptide. The amino-acid sequence. Use of kallikrein in its determination. *Eur J Biochem* 42, 581-589.
- Nicole, P., Du, K., Couvineau, A., and Laburthe, M. (1998). Site-directed mutagenesis of human VIP1 versus VIP2 receptors. *Ann N Y Acad Sci* 865, 378-381.
- O'Dorisio, M.S., Hermina, N.S., O'Dorisio, T.M., and Balcerzak, S.P. (1981). Vasoactive intestinal polypeptide modulation of lymphocyte adenylate cyclase. *J Immunol* 127, 2551-2554.
- Offermanns, S., and Simon, M.I. (1996). Organization of transmembrane signalling by heterotrimeric G proteins. *Cancer Surv* 27, 177-198.
- Ohtaki, H., Nakamachi, T., Dohi, K., Aizawa, Y., Takaki, A., Hodoyama, K., Yofu, S., Hashimoto, H., Shintani, N., Baba, A., *et al.* (2006). Pituitary adenylate cyclase-activating polypeptide (PACAP) decreases ischemic neuronal cell death in association with IL-6. *Proc Natl Acad Sci U S A* 103, 7488-7493.
- Ottaway, C.A. (1987). Selective effects of vasoactive intestinal peptide on the mitogenic response of murine T cells. *Immunology* 62, 291-297.
- Pakbaz, H., Foda, H.D., Berisha, H.I., Trotz, M., and Said, S.I. (1993). Paraquat-induced lung injury: prevention by vasoactive intestinal peptide and related peptide helodermin. *Am J Physiol* 265, L369-373.
- Parnot, C., Miserey-Lenkei, S., Bardin, S., Corvol, P., and Clauser, E. (2002). Lessons from constitutively active mutants of G protein-coupled receptors. *Trends Endocrinol Metab* 13, 336-343.
- Philpott, N.J., Turner, A.J., Scopes, J., Westby, M., Marsh, J.C., Gordon-Smith, E.C., Dalglish, A.G., and Gibson, F.M. (1996). The use of 7-amino actinomycin D in identifying apoptosis: simplicity of use and broad spectrum of application compared with other techniques. *Blood* 87, 2244-2251.
- Pincus, D.W., DiCicco-Bloom, E.M., and Black, I.B. (1990a). Vasoactive intestinal peptide regulates mitosis, differentiation and survival of cultured sympathetic neuroblasts. *Nature* 343, 564-567.
- Pincus, D.W., DiCicco-Bloom, E.M., and Black, I.B. (1990b). Vasoactive intestinal peptide regulation of neuroblast mitosis and survival: role of cAMP. *Brain Res* 514, 355-357.
- Piper, P.J., Said, S.I., and Vane, J.R. (1970). Effects on smooth muscle preparations of unidentified vasoactive peptides from intestine and lung. *Nature* 225, 1144-1146.

- Pitcher, J.A., Hall, R.A., Daaka, Y., Zhang, J., Ferguson, S.S., Hester, S., Miller, S., Caron, M.G., Lefkowitz, R.J., and Barak, L.S. (1998). The G protein-coupled receptor kinase 2 is a microtubule-associated protein kinase that phosphorylates tubulin. *J Biol Chem* 273, 12316-12324.
- Qian, B.F., Hammarstrom, M.L., and Danielsson, A. (2001). Differential expression of vasoactive intestinal polypeptide receptor 1 and 2 mRNA in murine intestinal T lymphocyte subtypes. *J Neuroendocrinol* 13, 818-825.
- Radhika, V., and Dhanasekaran, N. (2001). Transforming G proteins. *Oncogene* 20, 1607-1614.
- Rawlings, S.R., and Hezareh, M. (1996). Pituitary adenylate cyclase-activating polypeptide (PACAP) and PACAP/vasoactive intestinal polypeptide receptors: actions on the anterior pituitary gland. *Endocr Rev* 17, 4-29.
- Reubi, J.C., Laderach, U., Waser, B., Gebbers, J.O., Robberecht, P., and Laissue, J.A. (2000). Vasoactive intestinal peptide/pituitary adenylate cyclase-activating peptide receptor subtypes in human tumors and their tissues of origin. *Cancer Res* 60, 3105-3112.
- Rola-Pleszczynski, M., Bolduc, D., and St-Pierre, S. (1985). The effects of vasoactive intestinal peptide on human natural killer cell function. *J Immunol* 135, 2569-2573.
- Rydell, E.L., Axelsson, K.L., and Olofsson, J. (1988). Protein kinase C activity in normal and neoplastic squamous epithelia from the upper aero-digestive tract. *Second Messengers Phosphoproteins* 12, 155-162.
- Said, S.I., and Dickman, K.G. (2000). Pathways of inflammation and cell death in the lung: modulation by vasoactive intestinal peptide. *Regul Pept* 93, 21-29.
- Said, S.I., and Mutt, V. (1970). Potent peripheral and splanchnic vasodilator peptide from normal gut. *Nature* 225, 863-864.
- Samanta, A.K., Oppenheim, J.J., and Matsushima, K. (1990). Interleukin 8 (monocyte-derived neutrophil chemotactic factor) dynamically regulates its own receptor expression on human neutrophils. *J Biol Chem* 265, 183-189.
- Schmid, I., Uittenbogaart, C.H., Keld, B., and Giorgi, J.V. (1994). A rapid method for measuring apoptosis and dual-color immunofluorescence by single laser flow cytometry. *J Immunol Methods* 170, 145-157.
- Segre, G.V., Abou-Samra, A.B., Juppner, H., Schipani, E., Force, T., Urena, P., Freeman, M., Kong, X.F., Kolakowski, L.F., Jr., Hock, J., *et al.* (1992). Characterization of cloned PTH/PTHrP receptors. *J Endocrinol Invest* 15, 11-17.
- Segre, G.V., and Goldring, S.R. (1993). Receptors for secretin, calcitonin, parathyroid hormone (PTH)/PTH-related peptide, vasoactive intestinal peptide, glucagonlike peptide 1, growth hormone-releasing hormone, and glucagon belong to a newly discovered G-protein-linked receptor family. *Trends Endocrinol Metab* 4, 309-314.
- Severi, C., Tattoli, I., Corleto, V.D., Maselli, M.A., Trisolini, P., and Delle Fave, G. (2006). Vasoactive intestinal peptide receptor subtypes and signalling pathways involved in relaxation of human stomach. *Neurogastroenterol Motil* 18, 1009-1018.

- Shen, S., Spratt, C., Sheward, W.J., Kallo, I., West, K., Morrison, C.F., Coen, C.W., Marston, H.M., and Harmar, A.J. (2000). Overexpression of the human VPAC2 receptor in the suprachiasmatic nucleus alters the circadian phenotype of mice. *Proc Natl Acad Sci U S A* 97, 11575-11580.
- Shetzline, M.A., Premont, R.T., Walker, J.K., Vigna, S.R., and Caron, M.G. (1998). A role for receptor kinases in the regulation of class II G protein-coupled receptors. Phosphorylation and desensitization of the secretin receptor. *J Biol Chem* 273, 6756-6762.
- Shetzline, M.A., Walker, J.K., Valenzano, K.J., and Premont, R.T. (2002). Vasoactive intestinal polypeptide type-1 receptor regulation. Desensitization, phosphorylation, and sequestration. *J Biol Chem* 277, 25519-25526.
- Skalhegg, B.S., Tasken, K., Hansson, V., Huitfeldt, H.S., Jahnsen, T., and Lea, T. (1994). Location of cAMP-dependent protein kinase type I with the TCR-CD3 complex. *Science* 263, 84-87.
- Spengler, D., Waeber, C., Pantaloni, C., Holsboer, F., Bockaert, J., Seeburg, P.H., and Journot, L. (1993). Differential signal transduction by five splice variants of the PACAP receptor. *Nature* 365, 170-175.
- Sreedharan, S.P., Huang, J.X., Cheung, M.C., and Goetzl, E.J. (1995). Structure, expression, and chromosomal localization of the type I human vasoactive intestinal peptide receptor gene. *Proc Natl Acad Sci U S A* 92, 2939-2943.
- Sumitomo, M., Milowsky, M.I., Shen, R., Navarro, D., Dai, J., Asano, T., Hayakawa, M., and Nanus, D.M. (2001). Neutral endopeptidase inhibits neuropeptide-mediated transactivation of the insulin-like growth factor receptor-Akt cell survival pathway. *Cancer Res* 61, 3294-3298.
- Sun, L., and Ganea, D. (1993). Vasoactive intestinal peptide inhibits interleukin (IL)-2 and IL-4 production through different molecular mechanisms in T cells activated via the T cell receptor/CD3 complex. *J Neuroimmunol* 48, 59-69.
- Tatemoto, K., and Mutt, V. (1981). Isolation and characterization of the intestinal peptide porcine PHI (PHI-27), a new member of the glucagon--secretin family. *Proc Natl Acad Sci U S A* 78, 6603-6607.
- Taub, D.D., Conlon, K., Lloyd, A.R., Oppenheim, J.J., and Kelvin, D.J. (1993). Preferential migration of activated CD4+ and CD8+ T cells in response to MIP-1 alpha and MIP-1 beta. *Science* 260, 355-358.
- Tsutsumi, M., Claus, T.H., Liang, Y., Li, Y., Yang, L., Zhu, J., Dela Cruz, F., Peng, X., Chen, H., Yung, S.L., *et al.* (2002). A potent and highly selective VPAC2 agonist enhances glucose-induced insulin release and glucose disposal: a potential therapy for type 2 diabetes. *Diabetes* 51, 1453-1460.
- Uchida, D., Arimura, A., Somogyvari-Vigh, A., Shioda, S., and Banks, W.A. (1996). Prevention of ischemia-induced death of hippocampal neurons by pituitary adenylate cyclase activating polypeptide. *Brain Res* 736, 280-286.

- Usdin, T.B., Bonner, T.I., and Mezey, E. (1994). Two receptors for vasoactive intestinal polypeptide with similar specificity and complementary distributions. *Endocrinology* *135*, 2662-2680.
- Voice, J.K., Dorsam, G., Lee, H., Kong, Y., and Goetzl, E.J. (2001). Allergic diathesis in transgenic mice with constitutive T cell expression of inducible vasoactive intestinal peptide receptor. *Faseb J* *15*, 2489-2496.
- Walton, M.R., and Dragunow, I. (2000). Is CREB a key to neuronal survival? *Trends Neurosci* *23*, 48-53.
- Wang, H.Y., Jiang, X., Gozes, I., Fridkin, M., Brenneman, D.E., and Ganea, D. (1999). Vasoactive intestinal peptide inhibits cytokine production in T lymphocytes through cAMP-dependent and cAMP-independent mechanisms. *Regul Pept* *84*, 55-67.
- Wang, J.M., McVicar, D.W., Oppenheim, J.J., and Kelvin, D.J. (1993). Identification of RANTES receptors on human monocytic cells: competition for binding and desensitization by homologous chemotactic cytokines. *J Exp Med* *177*, 699-705.
- Waschek, J.A. (1995). Vasoactive intestinal peptide: an important trophic factor and developmental regulator? *Dev Neurosci* *17*, 1-7.
- Waschek, J.A. (1996). VIP and PACAP receptor-mediated actions on cell proliferation and survival. *Ann N Y Acad Sci* *805*, 290-300; discussion 300-291.
- Waschek, J.A., Bravo, D.T., and Richards, M.L. (1995). High levels of vasoactive intestinal peptide/pituitary adenylate cyclase-activating peptide receptor mRNA expression in primary and tumor lymphoid cells. *Regul Pept* *60*, 149-157.
- Wess, J. (1997). G-protein-coupled receptors: molecular mechanisms involved in receptor activation and selectivity of G-protein recognition. *Faseb J* *11*, 346-354.
- Wess, J., Liu, J., Blin, N., Yun, J., Lerche, C., and Kostenis, E. (1997). Structural basis of receptor/G protein coupling selectivity studied with muscarinic receptors as model systems. *Life Sci* *60*, 1007-1014.
- Wilkinson, P.C. (1996). Cell Locomotion and Chemotaxis: Basic Concepts and Methodological Approaches. *Methods* *10*, 74-81.
- Xia, M., Gaufo, G.O., Wang, Q., Sreedharan, S.P., and Goetzl, E.J. (1996). Transduction of specific inhibition of HuT 78 human T cell chemotaxis by type I vasoactive intestinal peptide receptors. *J Immunol* *157*, 1132-1138.
- Xia, M., Sreedharan, S.P., Bolin, D.R., Gaufo, G.O., and Goetzl, E.J. (1997). Novel cyclic peptide agonist of high potency and selectivity for the type II vasoactive intestinal peptide receptor. *J Pharmacol Exp Ther* *281*, 629-633.
- Xin, Z., Tang, H., and Ganea, D. (1994). Vasoactive intestinal peptide inhibits interleukin (IL)-2 and IL-4 production in murine thymocytes activated via the TCR/CD3 complex. *J Neuroimmunol* *54*, 59-68.
- Zaccolo, M., and Pozzan, T. (2003). cAMP and Ca<sup>2+</sup> interplay: a matter of oscillation patterns. *Trends Neurosci* *26*, 53-55.

Zawilska, J.B., Dejda, A., Niewiadomski, P., Gozes, I., and Nowak, J.Z. (2005). Receptors for VIP and PACAP in guinea pig cerebral cortex: effects on cyclic AMP synthesis and characterization by <sup>125</sup>I-VIP binding. *J Mol Neurosci* 25, 215-224.

## **7. Abbreviations**

7-AAD 7-Amino-actinomycin D

AC Adenylyl cyclase

ATP adenosine triphosphate

Bp base pair

°C grad celsius

Ca Calcium

CaM, calmodulin

cAMP cyclic adenosine monophosphate

cDNA complement desoxyribonucleinacid

CHO chinese hamster ovary

CNS central nervous system

Cpm counts per minute

CREB cAMP response element binding protein

DAG diacyl glycerol

DEPC Diethylpyrocarbonate

DNase desoxyribonuclease

EC extracellular

E.coli Escherichia coli

EDTA Ethylendiamintetraacetat

ELISA enzyme-linked immuno-absorbent assay

ER endoplasmatisches reticulum

FACS fluorescence-activated cell scanning

FBS fetal bovine serum

G gramm

GDP guanosine diphosphate

GEF guanine nucleotide exchange factor

GPCR G-protein coupled receptor

GTP guanosine triphosphate

IC intracellular

Ins (1,4,5) P<sub>3</sub>, inositol 1,4,5-trisphosphate

kDa kilodalton

min minute

ml milliliter

MMP matrixmetalloproteinase

Mw molecular weight

Nt nucleotide

PAC pituitary adenylate

PACAP Pituitary Adenylate Cyclase-Activating Polypeptide

PBS phosphate buffered saline

PCR polymerase chain reaction

pIRES primary internal ribosomal entry side

PIP2 phosphatidyl inositol 4,5-bisphosphate

PKA Proteinkinase A

PKC, protein kinase C

PLC Phospholipase C

PLD phosholipase D

RA Rheumatoid arthritis



RNA Ribonucleic acid

hSDF-1 human stromal-derived factor-1

TBE TRIS-Borat-EDTA-Puffer

TM Transmembrane

µg microgram

UCSF University of California San Francisco

V Volt

VIP Vasoactive intestinal peptide

VPACR Vasoactive intestinal peptide receptor

## **8. Acknowledgements**

Die Untersuchungen zu dieser Arbeit wurden in der Immunologischen Abteilung (Leiter Prof. E. Goetzl) an der University of California durchgeführt. Ganz besonderer Dank gilt Prof. Dr. med. E. Goetzl der mir sein Labor zur Durchführung der experimentellen Arbeiten uneingeschränkt zur Verfügung gestellt hat und mit Rat und Tat immer zur Seite stand.

Meinen Doktorvätern Herrn Prof. Dr. med S. Schewe und Herrn PD Dr. P. Nelson, der Ludwigs-Maximilians Universität München möchte ich für die außerordentliche Unterstützung meiner Arbeit und meiner Person ganz besonders danken, sowie der Korrekturlesung der Arbeit.

Ich danke ganz besonders Herrn Dr. med. K. Bastani für die außerordentlich engagierte und kompetente Betreuung bei den experimentellen Arbeiten, die vielen hilfreichen Ratschläge und Ideen bei wissenschaftlichen Fragestellungen ohne dessen Hilfe diese Arbeit nicht zustande gekommen wäre.

Auf dem langen Weg bis zur Abgabe dieser Dissertation haben mich viele Kollegen und Freunde begleitet. Ausgedehnte Diskussionen, Gespräche und Anregungen haben zum Gelingen dieser Arbeit beigetragen. An dieser Stelle möchte ich vor allem Rickmer Braren, Ingeborg Schaffhalter, Jürgen Fickler und Susan Watson herzlich danken.

Besonders lieber Dank gilt meinen Eltern und meiner Schwester, die mich uneingeschränkt während meiner ganzen medizinischen Laufbahn unterstützt haben und unter anderem auch diese Arbeit ermöglicht haben.

München, Februar 2010

Carola Grinninger

## 9. CURRICULUM VITAE

### PERSÖNLICHE DATEN

**Name:** Carola Grinninger  
**Geburtsdatum:** 30.12.1969 in München  
**Eltern:** Franz Grinninger  
Margarethe Grinninger geb. Sagerer  
**Nationalität:** deutsch  
**Familienstand:** verheiratet, 2 Kinder

### SCHULBILDUNG

**Werdenfels Grundschule München** 1993-1999  
**Thomas-Mann Gymnasium** 1998

### AUSBILDUNG

**Ludwig-Maximilians-Universität, München** 1993-1999  
**Faculte de Medecine Lariboisiere, Paris, Frankreich**  
Medizinstudent 1998  
**University of California San Francisco (UCSF)**  
Praktisches Jahr mit klinischen Rotationen in der Inneren  
Medizin (Kardiologie Dr. Karliner, Gastroenterologie Dr.  
McQuaid and Hematologie Dr. Cornett), Chirurgie Dr.  
Norton und Radiologie Dr. Goldberg. 1999

### STIPENDIEN

**Oskar-Karl-Forster Stipendium** 1998-1999  
**Ludwig-Maximilians-Universität, München**  
**Travel Award for the 6th International Symposium** 2003  
**on VIP, PACAP and related Peptides, Japan**  
**American Heart Association (AHA) Postdoctoral** 2007-2009  
**Fellowship**  
“Cardiac response to vascular endothelial growth factor  
gene expression: Dose-dependence and  
microenvironmental control” an der Universität von San  
Francisco

## **KLINISCHE ERFAHRUNG**

<b>Praktisches Jahr</b> Universität von San Francisco	1999-2000
<b>AiP</b> Krankenhaus München Bogenhausen Innere Medizin, Rheumatologie Technische Universität München Prof. Helmke	2000-2002
<b>Assistenzzeit</b> Hôpital Henri Duffaut Avignon, Rotationen in Kardiologie and Nephrologie Universität von Marseille, Frankreich Kardiologie Dr. Hirsch, Nephrologie Dr. Pollini	2004-2005
<b>Assistenzaushilfsdienste</b> Innere Medizin Krankenhaus, Peissenberg I Prof. Fischer	2006

## **FORSCHUNGSERFAHRUNG**

<b>Klinische Forschung</b> PHARMALOG, München	1997-1998
<b>Postdoctoral fellow</b> Department of Medicine, Immunology, (Prof. Edward Goetzl) University of California San Francisco (UCSF)	2002-2004
<b>Postdoctoral fellow</b> Department of Medicine, Cardiology (Prof. Matthew Springer) University of California San Francisco	2006-2009