



NOAA Technical Report NMFS 10

Proceedings of the Seventh
U.S.-Japan Meeting on
Aquaculture, Marine Finfish
Culture, Tokyo, Japan,
October 3-4, 1978

Carl J. Sindermann (Editor)

*Under the U.S.-Japan Cooperative Program
in Natural Resources (UJNR)*

Panel Chairmen:
SHIGEKATSU SATO - Japan
WILLIAM N. SHAW - United States

August 1984

U.S. DEPARTMENT OF COMMERCE
National Oceanic and Atmospheric Administration
National Marine Fisheries Service

NOAA TECHNICAL REPORTS NMFS

The major responsibilities of the National Marine Fisheries Service (NMFS) are to monitor and assess the abundance and geographic distribution of fishery resources, to understand and predict fluctuations in the quantity and distribution of these resources, and to establish levels for optimum use of the resources. NMFS is also charged with the development and implementation of policies for managing national fishing grounds, development and enforcement of domestic fisheries regulations, surveillance of foreign fishing off United States coastal waters, and the development and enforcement of international fishery agreements and policies. NMFS also assists the fishing industry through marketing service and economic analysis programs, and mortgage insurance and vessel construction subsidies. It collects, analyzes, and publishes statistics on various phases of the industry.

The NOAA Technical Report NMFS series was established in 1983 to replace two subcategories of the Technical Reports series: "Special Scientific Report—Fisheries" and "Circular." The series contains the following types of reports: Scientific investigations that document long-term continuing programs of NMFS, intensive scientific reports on studies of restricted scope, papers on applied fishery problems, technical reports of general interest intended to aid conservation and management, reports that review in considerable detail and at a high technical level certain broad areas of research, and technical papers originating in economics studies and from management investigations.

Copies of NOAA Technical Report NMFS are available free in limited numbers to governmental agencies, both Federal and State. They are also available in exchange for other scientific and technical publications in the marine sciences. Individual copies may be obtained from: Publications Services Branch (E/AI 13), National Environmental Satellite, Data, and Information Service, National Oceanic and Atmospheric Administration, U.S. Department of Commerce, 3300 Whitehaven St., Washington, DC 20235.

NOAA Technical Report NMFS 10



Proceedings of the Seventh
U.S.-Japan Meeting on
Aquaculture, Marine Finfish
Culture, Tokyo, Japan,
October 3-4, 1978

Carl J. Sindermann (Editor)

*Under the U.S.-Japan Cooperative Program
in Natural Resources (UJNR)*

August 1984

U.S. DEPARTMENT OF COMMERCE

Malcolm Baldrige, Secretary

National Oceanic and Atmospheric Administration

John V. Byrne, Administrator

National Marine Fisheries Service

William G. Gordon, Assistant Administrator for Fisheries

PREFACE

The United States and Japanese counterpart panels on aquaculture were formed in 1969 under the United States-Japan Cooperative Program in Natural Resources (UJNR). The panels currently include specialists drawn from the federal departments most concerned with aquaculture. Charged with exploring and developing bilateral cooperation, the panels have focused their efforts on exchanging information related to aquaculture which could be of benefit to both countries.

The UJNR was started by a proposal made during the Third Cabinet-Level Meeting of the Joint United States-Japan Committee on Trade and Economic Affairs in January 1964. In addition to aquaculture, current subjects in the program are desalination of seawater, toxic microorganisms, air pollution, energy, forage crops, national park management, mycoplasmosis, wind and seismic effects, protein resources, forestry, and several joint panels and committees in marine resources research, development, and utilization.

Accomplishments include: Increased communications and cooperation among technical specialists; exchanges of information, data, and research findings; annual meetings of the panels, a policy coordinative body; administration staff meetings; exchanges of equipment, materials, and samples; several major technical conferences; and beneficial effects on international relations.

Shigekatsu Sato - Japan
William N. Shaw - United States

CONTENTS

Papers presented by Japanese panel members:

FUKUHARA, O. Development of biological characters in early stages of seed production of commercially important marine fishes 3
MATSUSATO, T. Present status and future potential of yellowtail culture in Japan 11
OKAMOTO, R. Present status of red sea bream in Japan 17
TANIGUCHI, M. Practical problems in finfish culture in Kochi Prefecture 21

Papers presented by U.S. panel members:

ARNOLD, C. R. Maturation and spawning of marine finfish 25
STEVENS, B. Striped bass culture in the United States 29

The National Marine Fisheries Service (NMFS) does not approve, recommend or endorse any proprietary product or proprietary material mentioned in this publication. No reference shall be made to NMFS, or to this publication furnished by NMFS, in any advertising or sales promotion which would indicate or imply that NMFS approves, recommends or endorses any proprietary product or proprietary material mentioned herein, or which has as its purpose an intent to cause directly or indirectly the advertised product to be used or purchased because of this NMFS publication.

Joint Statement of the UJNR Aquaculture Panel October 3-4, 1978, Tokyo, Japan

The seventh session of the UJNR Aquaculture Panel convened in Tokyo, Japan, October 3-4, 1978. The subject of the session was marine finfish culture, excluding ocean ranching.

Mr. Haruhiko Horikawa, Director General, Secretariate, Agriculture, Forestry and Fishery Research Council, and Mr. Toshio Sugawara, chief, International Development Division, Science and Technology Agency, presented welcoming addresses and opening remarks.

Panel members and observers were introduced by respective chairman. Seven technical papers on finfish culture were presented by members of both panels. Presentation of technical papers was followed by discussion periods.

During the business session the scientist exchange program was reviewed and suggestions for future exchanges were presented. It was concluded that scientists from Japan, including Mr. T. Matsusato, would be sent to the United States to study fish pathology in 1979.

The U.S. panel presented five proposals:

- 1) That Japanese scientists contribute to and utilize the National Registry of Marine Pathology.
- 2) That the UJNR Aquaculture Panel support ICES in developing the Index of Marine Aquaculture Diseases.
- 3) That the UJNR Aquaculture Panel support a review on the effects of pollution on marine and freshwater aquaculture.
- 4) That Japanese scientists participate in the National Aquaculture Information System at the Virginia Institute of Marine Science.
- 5) That Japanese scientists participate with the University of California in a joint study on abalone seeding.

The Japanese Panel responded positively to items 2, 4, and 5. Proposals 1 and 3 will be given further consideration and correspondence will be exchanged on all five proposals.

A report on the ongoing cooperative study related to summer oyster mortality and the development of disease resistant oyster seed was presented by the Japanese Panel. The Japanese Panel also recommended that a joint study on oyster breeding be developed.

The U.S. Chairman discussed plans for the 1979 UJNR meeting on freshwater finfish culture. Field trips are planned including visits to catfish and bait fish farms and processing plants in the south, and salmon and trout farms and fish hatcheries in the northwest. Seattle, Washington, was suggested as the meeting site. A tentative travel schedule was presented. Ideally, the date of the next meeting will be in the autumn of 1979.

Respectfully submitted

Shigekatsu Sato - Japan
William N. Shaw - United States

Development of Biological Characters in Early Stages of Seed Production of Commercially Important Marine Fishes

OSAMU FUKUHARA¹

INTRODUCTION

In recent years, substantial progress in aquaculture technology has allowed the mass production of useful marine fishes. Presumably these efforts were undertaken since natural seed resources for farming were limited and the fishery of some economically important species had markedly decreased. Total production of marine fish fry reaches over 5 million seedlings annually, much of which is attributable to red sea bream, *Pagrus major*, (Fig. 1) as described by the Japan Fisheries Resource Conservation Association (1977) and Yamaguchi (1978). Aquaculturists have successfully reared larvae and fry from naturally spawned eggs to maturity, mostly for stocking net cages but also for the release program by prefectural and national hatcheries in order to recruit natural stocks within the Seto Inland Sea. Similar programs have been carried out for other species such as porgy, parrotfish, and Kuruma prawn. Much experimental work has been accomplished to identify optimum conditions for survival in both artificial and natural habitats. These investigations contribute to our knowledge of survival and yield of liberated animals.

In order to ascertain optimum environmental rearing conditions and habitat structures as well as optimum seed size for release, it is useful to study the development of morphological characteristics of fry in relation to their behavioral development in given environments. The development of biological characteristics in both reared and wild fish is not well known.

This paper describes briefly the morphological development of the red sea bream, *Pagrus major*, porgy, *Acanthopagrus schlegelii*, and parrotfish, *Oplegnathus fasciatus*, on which artificial propagation and releasing programs have been performed extensively in Japan. The significance of differentiation during the life cycle of these fishes is stressed. Furthermore, the adaptability of seedlings to changing environmental conditions during cultivation is discussed for various developmental stages with special reference to the optimum stage for releasing and intensive farming.

Discussion and conclusions are based on morphological observations of external organs, i.e., fins, scales, and transverse stripes, from fishes reared under laboratory conditions.

REASONS FOR THE DEVELOPMENT OF MASS PRODUCTION PROCEDURES

Environmental rearing conditions significantly affect some biological characters of artificially produced juveniles. It is therefore desirable to control important environmental factors

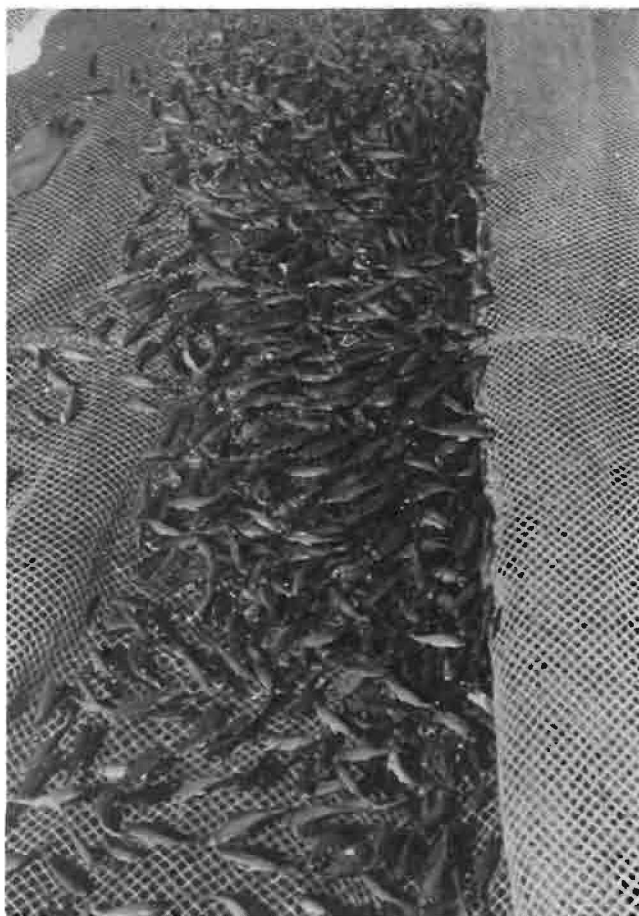

Figure 1.—Seedlings of red sea bream, *Pagrus major*, reared from eggs and raised in net cages.

during the entire rearing period, as well as during and just prior to the spawning period. The main steps in the operational procedures for mass propagation are outlined diagrammatically in Figure 2. The life cycles of most fishes used for aquaculture are controlled artificially; this is also the case with the red sea bream, porgy, and parrotfish. Control of the whole life cycle, breeding the fish from egg to maturity, allows a continuous high production of seeds for any of these species. Therefore, techniques for complete control of the life cycle should be increasingly adopted for the mass propagation of useful marine organisms. The main procedures of larval rearing of the three most important species, red sea bream, porgy, and parrotfish, are outlined below.

¹Nansei Regional Fisheries Research Laboratory, Ohno-cho, Saeki-gun, Hiroshima Prefecture, Japan 739-04.

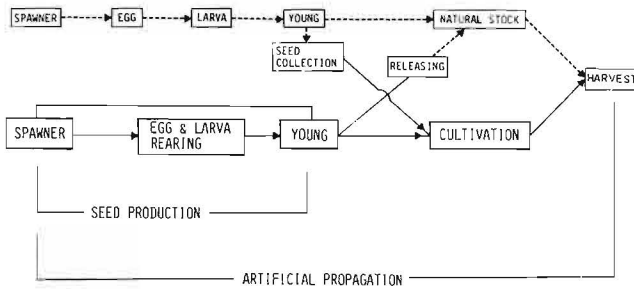

Figure 2.—Outline of operational procedures for artificial mass propagation of marine fish. Upper units shown in broken lines are probably found in natural grounds and those shown in solid lines show the sequence of artificial propagation. Wild fish are sometimes captured as seed fish for net-cage culture, and raised fish are also released to recruit the natural resources. Spawners can be obtained among the raised fish.

Egg Collection

Parental fish are kept in tanks on land for natural spawning. Spawners are taken from fish raised from egg to maturity, or they are captured as adults from wild stock. In either case, adult spawners 3-6 yr old are usually maintained at a density of 1-3 fish/m³ in net cages of about 70-100 m³ capacity or in settling tanks of 10-100 m³ volume until the spawning season approaches (Fig. 3). A higher percentage of fertilization and viable hatched larvae occur in natural spawning, when compared with artificial fertilization techniques. Therefore, natural spawning is preferred. In general, it is possible to obtain more than 90% fertilization and 2 to 5 million viable eggs from one female during the spawning season when using natural spawning techniques.



Figure 3.—Spawned eggs are collected in a fine-meshed net through the outlet of the concrete tank containing parent fish.

Larval Rearing

Newly hatched larvae are usually maintained in 1-100 m³ capacity rearing tanks (Figs. 4, 7) at a density of about 5-50 larvae/l. Water in the tank is exchanged as needed during the initial 2 to 3 wk and exchange rates gradually increase. "Flow through" systems are employed after the transitional or juvenile



Figure 4.—The smallest plastic containers used for larval rearing. They are usually installed indoors or under cover.

stage, about 20-35 d after hatching depending on ambient water temperature.

Larvae are initially fed marine rotifers, *Brachionus plicatilis*, (Fig. 5) cultured artificially with phytoplankton in the tank. In general, the density of rotifers in the rearing tank is maintained at a level of more than 5 individuals/ml. Trochophores of the Japanese oyster, *Crassostrea gigas*, are used as food organisms for initial feeding in small-scale culture, but are not utilized for feeding larvae in large-scale culture due to the difficulty of securing and preparing large numbers. Copepods (*Tigriopus japonicus*) (Fig. 5) are then introduced into the rearing tanks as the fish approach the juvenile stage and their initial feeding period overlaps partly with that of marine rotifers. *Artemia* nauplii are occasionally supplemented to the *T. japonicus* diet. Minced and/or chopped meat of fish, shellfish, and artificial combined diets are given just prior to and after the transitional phase. An experiment on synthetic diets has been carried out recently that would allow pellet feeding at very early stages. It is hoped that there will soon be some progress in this field.

High mortality during rearing trials is occasionally encountered at the transitional phase from larva to juvenile. Low mortality,

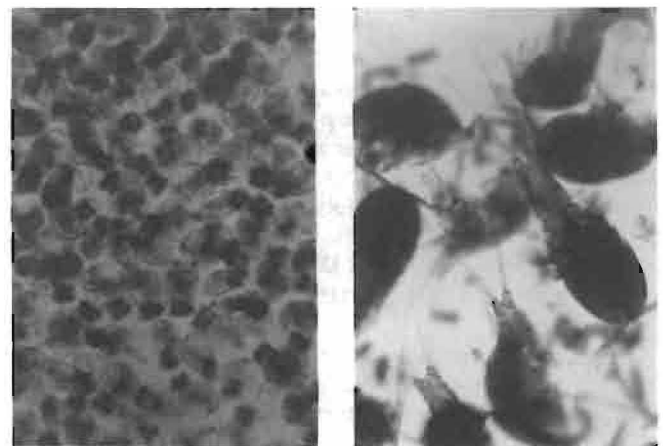

Figure 5.—Marine rotifer, *Brachionus plicatilis* (left) and copepod, *Tigriopus japonicus* (right) cultured under laboratory conditions.

however, is observed generally after metamorphosis. Therefore, reliable estimates of survival potential are possible beyond this stage. Survival can be $> 50\%$ or $< 5\%$ of the initial stock. One of the most important factors in continuous aquaculture operations is to obtain stable survival rates.

Metamorphosed fish are usually transferred from indoor rearing tanks to rearing facilities such as floating net cages or large outdoor tanks (Figs. 6, 7). When net cages are used, an electric bulb is often installed at night above each of them to attract plankton which enter the net cage through the mesh. This procedure is continued for a few days after transfer of the fish from the tanks to the cages. Fish are transferred with a siphon and/or container. Densities of 1,000 to 3,000 fish/m³ are used to rear fish up to 10-20 mm SL; thereafter, stocking density in floating net cages is reduced as the fish grows.

Plankton Culture

Large tanks are generally used in culturing phytoplankton and zooplankton (Fig. 7). First, agricultural fertilizers are added to the settling tank of cultured phytoplankton at the rate of about 100 g

ammonium sulfate/m³, 50 g calcium superphosphate/m³, and 10 g urea/m³. Inocula of single-celled algae (*Chlorella*), called green water, are then introduced into the tank and cultured to a concentration of about 20-30 million cells/ml. This is used to feed marine rotifers (*Brachionus plicatilis*) and copepods (*Tigriopus*). Recently, bread yeast has been employed as a supplementary foodstuff for zooplankton culture, due to the long period needed for blooming of *Chlorella* and the huge number of rotifers needed in large-scale fish propagation.

The density of marine rotifers cultured with green water is commonly only 50-70 individuals/ml; for rotifers cultured with bread yeast, it is common to obtain a density of 500 individuals/ml. The culture of marine rotifers with bread yeast, however, creates some nutritional problems involving fatty acids, causing high mortalities and skeletal deformities in the reared fishes (Kitajima et al. 1977; Fukuhara 1977a).

After several trials to avoid the ill effects of yeast feeding, it became clear that using a mixture of yeast and cultured *Chlorella* decreased the influence of yeast feeding mentioned above. Therefore, combined feeding of both yeast and algae is employed to culture food organisms at high densities. This seems to produce rotifers of high nutritional quality. Culture techniques of the copepod *Tigriopus japonicus* are not as efficient as those of the marine rotifer. Densities between about 1,000 and 2,000 individuals/l are obtained at practical levels.

DEVELOPMENT OF EXTERNAL ORGANS

Optimum utilization of the designated species at each developmental stage may be based on observations of morphological features which affect behavior and habitat, not only in the wild but also under rearing conditions.

Fin Development

The fin is a functionally important and primitive organ intimately related to locomotion. In most species, fins are formed at an early stage in the life history. Figure 8 illustrates contour changes of fins in reared red sea bream and parrotfish from newly hatched larvae to juvenile stages (Fukuhara 1976a; Fukuhara and Ito 1978). Fin development of porgy is comparable with that of red sea bream (Fukuhara 1977b). Larvae at this stage swim in the upper layer of the rearing tanks by undulating body movements until Stage D. Postlarvae with a continuous fin fold are subject to water movement from aeration in the rearing tank. Striking behavioral changes, however, are observed after the Stage E juvenile. Most of the surviving red sea bream and porgy swim in the lower layer of the rearing tank. Cannibalism, as well as territorial and aggressive behavior patterns, is observed. Those patterns are more pronounced for red sea bream fry than for parrotfish. At this juvenile stage, living food organisms such as marine rotifers and copepods are replaced by ground food such as minced and/or chopped meat of mussels and fishes.

During ray development in paired and unpaired fins, segmentation of each fin commences at the size range of 6-8 mm SL and is completed at about 10 mm SL except for the pectoral fin which is completed at about 18 mm SL in red sea bream and parrotfish, and at 15 mm SL in porgy. After the completion of ray segmentation, branching begins. Branching in the three species is complete at about 30 mm SL. Segmentation and branching are significant characters in ascertaining the functional development of the fins. Functional changes of the fins are induced by the progress of



Figure 6.—Floating net cage, 5 × 5 × 4 m used for rearing of fish after metamorphosis. Mesh size of net is changed according to fish growth.



Figure 7.—Outdoor tanks utilized for phytoplankton cultures; sometimes they are also employed for raising juveniles.

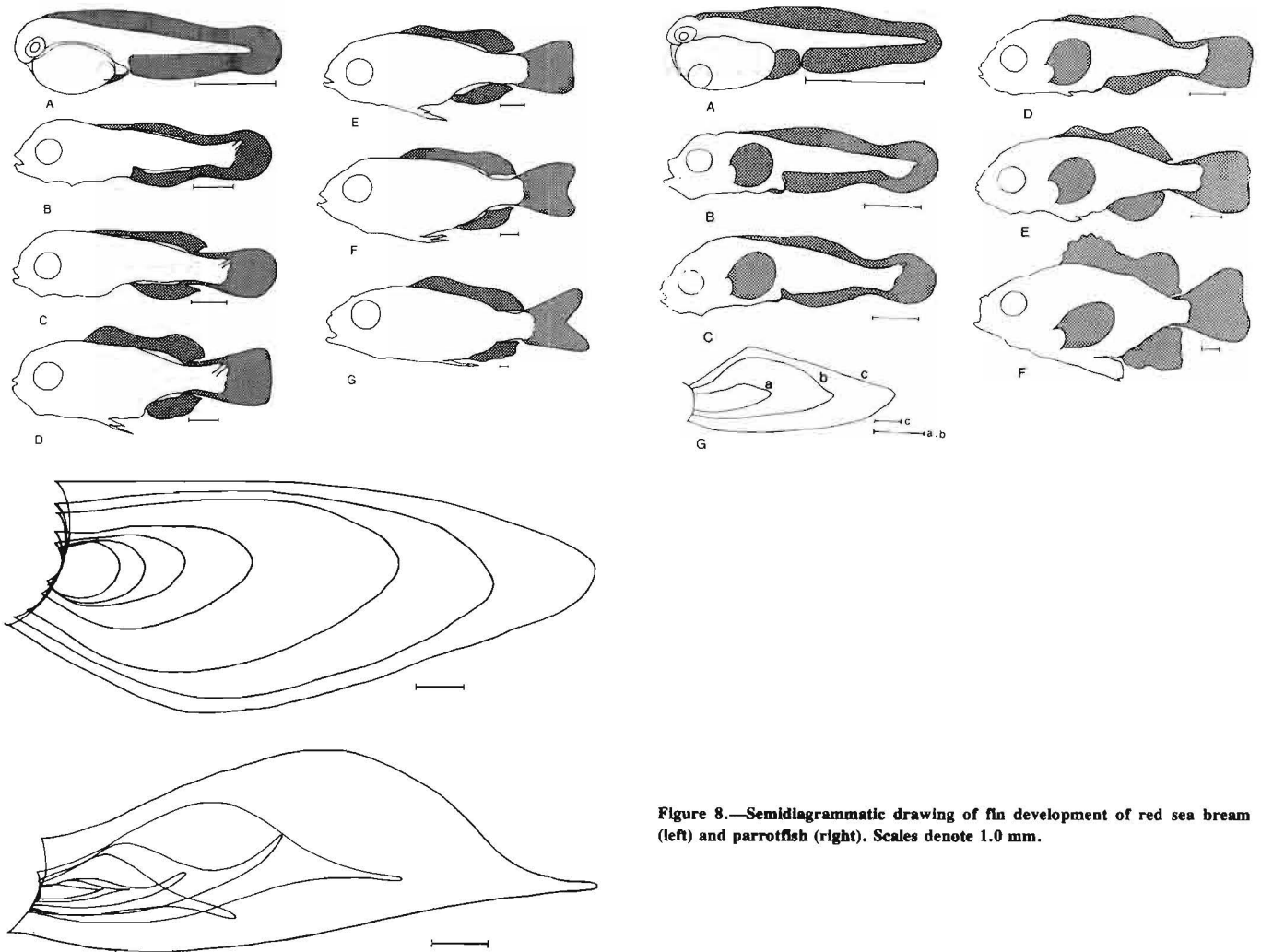

Figure 8.—Semidiagrammatic drawing of fin development of red sea bream (left) and parrotfish (right). Scales denote 1.0 mm.

segmentation and branching, which largely influence the development of larval behavior.

Metamorphosed fish with completely segmented fin rays are hardy during transportation from rearing tanks to succeeding rearing facilities such as outdoor tanks or floating net cages. Juveniles of about 30 mm SL, with branched fin rays, display new behaviors which more closely approximate those of the adults.

Morphological development of paired fins is similar to that of unpaired fins.

Scale Development

The functional role of scales is generally considered to be protection of the body surface from external stimuli or variations in environmental conditions. Scales of the fish treated in this paper are of the ctenoid type. Based upon their functional role only, development of scales reflects the increased ability of the fish to endure and adapt to various stimuli encountered in changing environmental conditions, such as water temperature, salinity, and water current.

Formation of the scales is shown in Figure 9. In the three species considered, squamation occurs at the transitional phase from postlarva to juvenile (i.e., 7 mm SL for red sea bream, 10 mm SL for porgy, and 12 mm SL for parrotfish) and forms quickly, taking about 1 wk from initial formation to completion for red

sea bream (Fukuhara 1976b) and porgy, and about 2 wk for parrotfish (Fig. 10). The scales increase in length as the fish grow, while the outline of the scales changes from the placoid to ctenoid type. The size of the fish at which the scale assumes ctenoid form is 30 mm SL for red sea bream and porgy and 50 mm SL for parrotfish. Structural features of the scales — ctenii, ridges, and grooves — increase in number as the fish grow.

Formation of Black Stripes

Transverse stripes of red sea bream and porgy are not clearly distinguishable in the adult form, but are quite clear in adult parrotfish. Band formation in each species occurs during the early stages of its life history. The black stripes are thought to be involved in concealment, communication, and advertisement. Formation of black stripes of each species shown in Figure 11 begins before and continues after the transitional phase when the juveniles attain about 8.0-10.0 mm in standard length (Fig. 12).

Transverse stripe formation is complete in about 2 wk for red sea bream (Fukuhara 1978) and parrotfish (Fukusho 1975), and about 3 wk for porgy, appearing at the anterior portion near the head for parrotfish and porgy, and the posterior portion for red sea bream (Fig. 11).

Functionally, completion of the formation of transverse stripes in the juveniles may be adaptive for concealment after the transi-

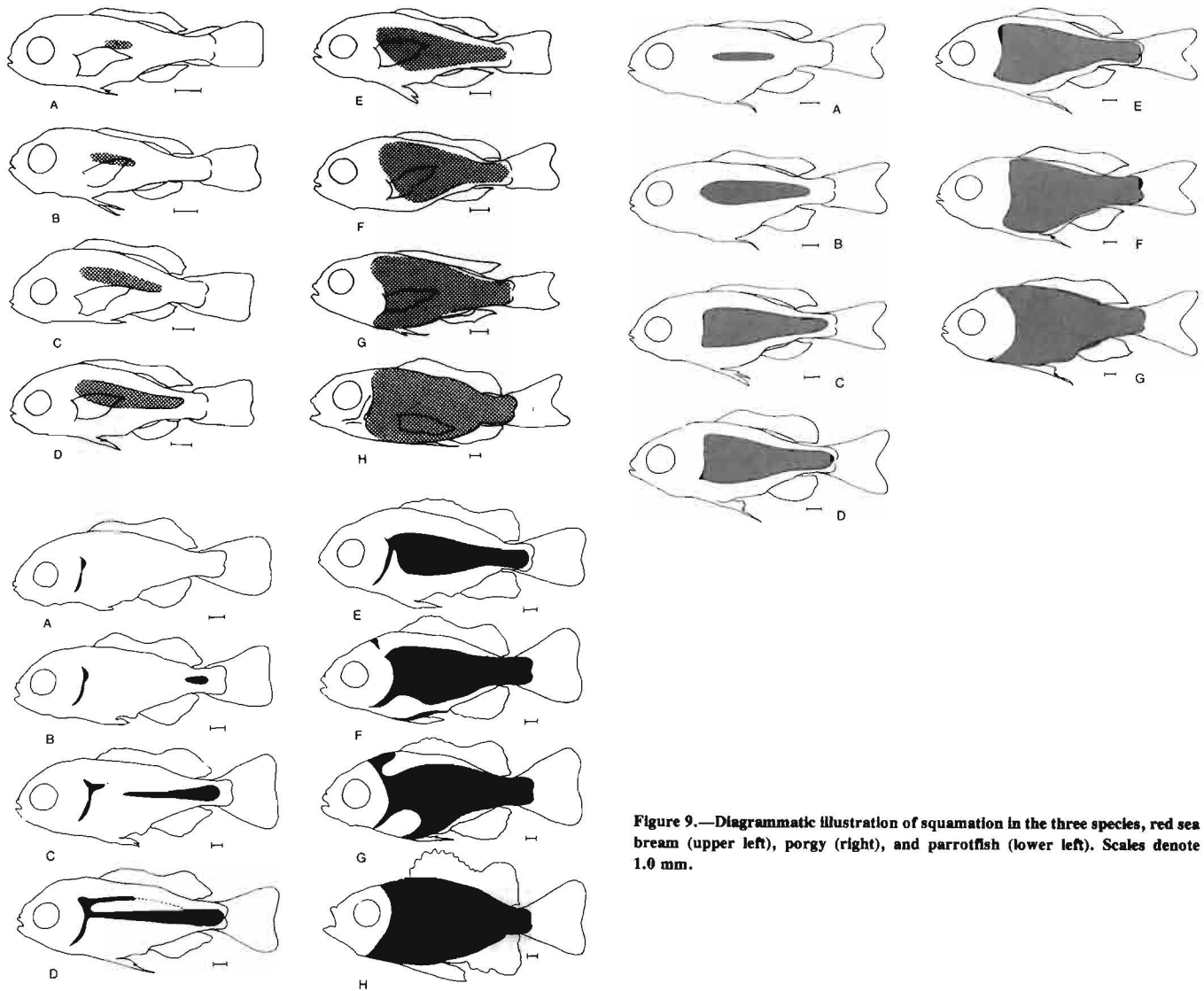

Figure 9.—Diagrammatic illustration of squamation in the three species, red sea bream (upper left), porgy (right), and parrotfish (lower left). Scales denote 1.0 mm.

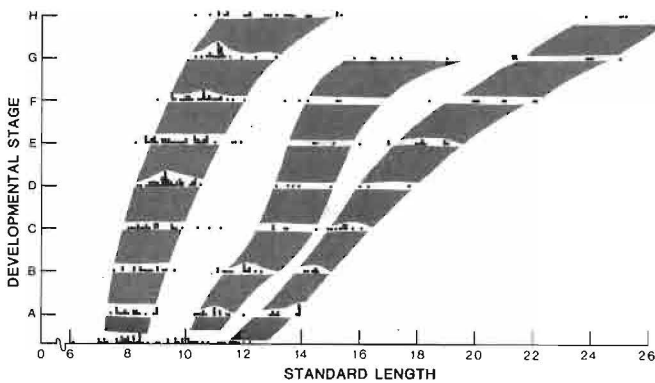

Figure 10.—Relation between developmental stage of squamation and standard length for (left to right) red sea bream, porgy, and parrotfish. Refer to Figure 9 for illustrations of the developmental stage for each species.

tion from the pelagic environment in which they have been living to a new habitat where rocks and vertical seaweeds are added.

MORPHOLOGICAL DEVELOPMENT AND RELATION TO BEHAVIOR

A similar sequence in the development of morphological and behavioral changes is observed in all three species. In Figure 13, the sequence of development of morphological characters in red sea bream is illustrated, along with various behavioral changes of the red sea bream observed in the rearing tank.

Formation of the observed organs begins before and is completed after the transitional phase from postlarva to juvenile. At the same time, feeding habits change from a diet of live food organisms, such as rotifers and copepods, to a diet of dead food consisting of minced meat of mussels and fishes. Behaviorally, fish which have swum in the upper layer of the rearing tank move to the middle and/or lower layers; this new mode occurs simultaneously among the fish.

In conclusion, it is assumed that during the transitional period in morphological development and behavioral characteristics, namely between about 8 and 10 mm SL, the fry are very sensitive to variations in environmental conditions. At 30 mm SL, formation of such external morphological features as fins, scales, and

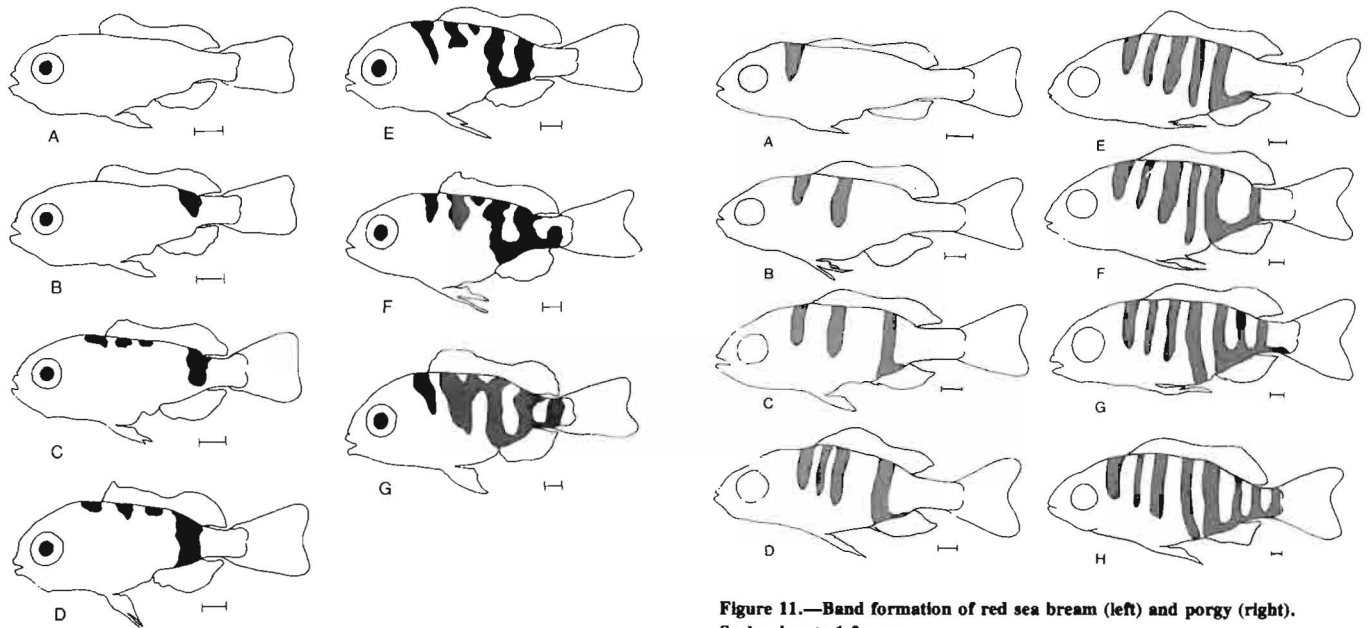

Figure 11.—Band formation of red sea bream (left) and porgy (right). Scales denote 1.0 mm.

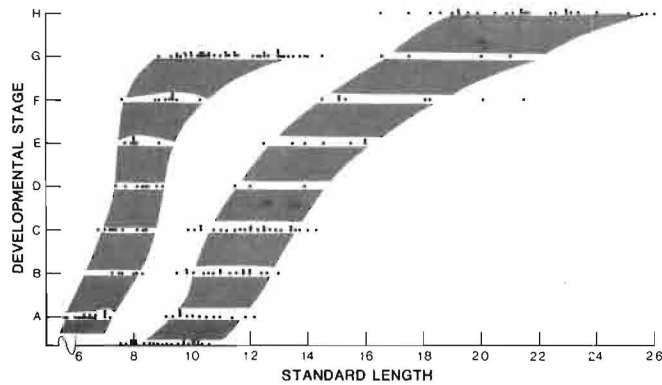

Figure 12.—Development of black stripes plotted against standard length for red sea bream (left) and porgy (right). Refer to Figure 11 for the developmental stage.

transverse stripes, are mostly completed and these features are nearly equivalent to those of the adults. Therefore, it is considered reasonable in terms of the functional development of organs and adaptability of fish to environmental conditions, that a size of 30 mm SL is suitable as the minimum seedling size for farming and releasing.

To obtain high survival rates of liberated animals, it is probably effective to use artificial reefs as protective areas from predation, incidental catching, and starvation during the critical phase immediately after release. It is also desirable to reduce the increasing overfishing of natural stocks, especially on young stages, and to obtain seed fish for net-cage culture by means of artificial rearing from eggs rather than by catching young wild fish. Gradually, fish farmers have realized the implications of these theories and now few farmers produce seeds for pen culture by themselves.

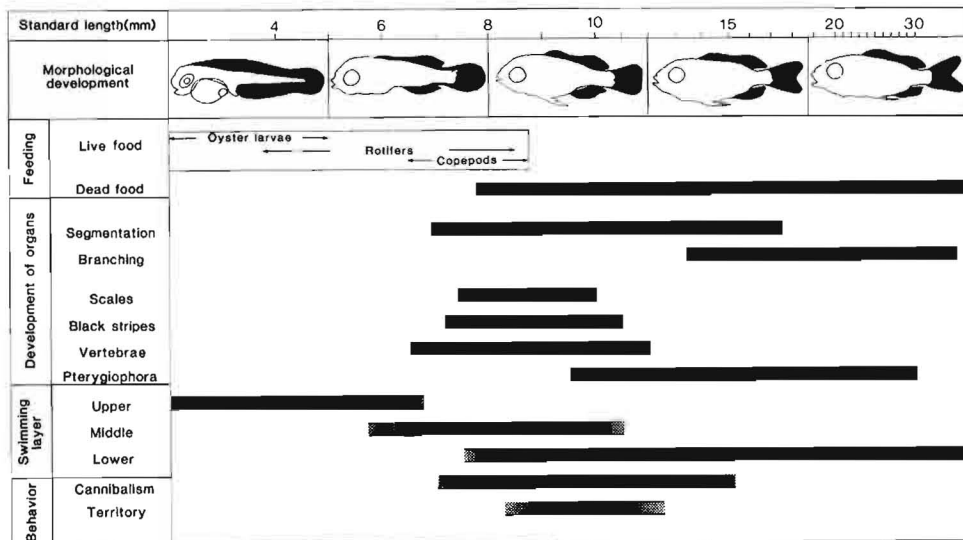

Figure 13.—Sequence of development and differentiation for various organs and behavior patterns in red sea bream reared under laboratory conditions.

ACKNOWLEDGMENTS

I am deeply grateful to M. Fujiya for his advice and critical reading of the manuscript. I also thank H. Rosenthal and K. Sokolski for their useful comments on the manuscript.

LITERATURE CITED

FUKUHARA, O.

- 1976a. Morphological studies of larva of red sea bream — I. Formation of fins. [In Jpn., Engl. summ.] Bull. Nansei Reg. Fish. Res. Lab. 9:1-11.
1976b. Morphological studies of larva and red sea bream — II. Early development of squamation. Bull. Nansei Reg. Fish. Res. Lab. 9:13-18.
1977a. On the skeletal abnormalities of reared red sea bream. [In Jpn., Engl. summ.] The Aquiculture 25(2):41-45.
1977b. Some morphological observations on larvae and juveniles of the kurodai, *Mylio macrocephalus* (Sparidae:teleostei) reared in the laboratory. Bull. Nansei Reg. Fish. Res. Lab. 10:1-16.

1978. Morphological studies of larva of red sea bream — III. Formation of black stripes. Bull. Nansei Reg. Fish. Res. Lab. 11:1-8.

FUKUHARA, O., and K. ITO.

1978. On the formation of the fins and squamation in the Japanese parrot fish, *Oplegnathus fasciatus* reared in the laboratory. Bull. Nansei Reg. Fish. Res. Lab. 11:9-17.

FUKUSHO, K.

1975. Development of color pattern in *Oplegnathus fasciatus*, useful indicator in rearing. [In Jpn., Engl. summ.] Jpn. J. Ichthyol. 22:23-30.

JAPANESE FISHERIES RESOURCE CONSERVATION ASSOCIATION.

1977. Present status and problems on seed production techniques for red sea bream. [In Jpn.] 179 p.

KITAJIMA, C., H. IWAMOTO, and S. FUJITA.

1977. Relation between curvature of vertebral column and undeveloped swim bladder in hatchery-reared red sea bream, *Pagrus major*. Bull. Nagasaki Pref. Inst. Fish. 3:23-32.

YAMAGUCHI, M.

1978. The basics and practices of red sea bream culture. [In Jpn.] Kouseisha kouseikaku, Tokyo, 414 p.

Present Status and Future Potential of Yellowtail Culture in Japan

TOSHIHIKO MATSUSATO¹

BACKGROUND

About 9,000 yr ago, the Japanese lived mostly along the coast and used many kinds of fishes as food. Fish bones were found in shell heaps on the coast of Tokyo Bay and were identified as belonging to 10-12 species including tuna, common mackerel, anchovy, common sea bass, red sea bream, black sea bream, flounder, mullet, horse mackerel, and yellowtail.

The Japanese like to eat fish; however, until 1950-55 low yields of commercial fisheries and inadequate culture methodology limited the supply of edible fishes. Moreover, the Japanese prefer raw fish rather than cooked fish. Raw fish, called "sashimi," requires very careful preparation. The quality of the meat is affected by changes in temperature that occur in refrigeration and freezing. Fish meats that can be used for sashimi are 3 to 10 times more expensive than the same kind of fish meats unsuitable for sashimi. Thus, culture and preservation methods are important in preparing sashimi.

Figure 1 compares the prices of live and dead red sea bream. Prices of live and dead yellowtail vary more than those of red sea

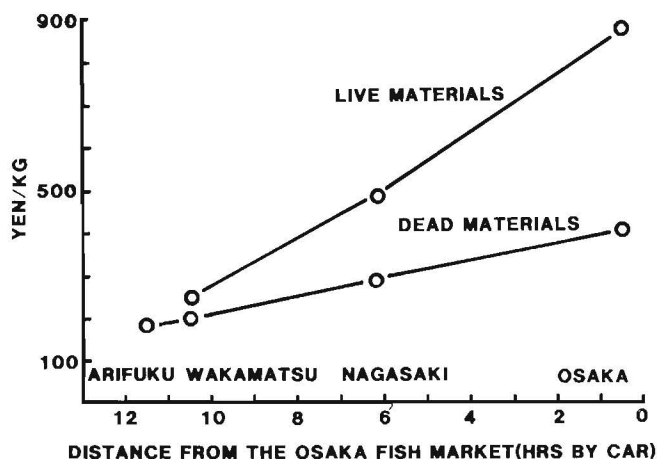

Figure 1.—Prices of live and dead red sea bream in different districts (after Yagi 1974).

bream. The price of dead fish ranges from 150 to 200 yen/kg; live fish cost from 750 to 800 yen/kg. Although cultured horse mackerel, *Trachurus japonicus*, are fed cheap horse mackerel from commercial fisheries, the cultured fish are very high priced (Statistics and Survey Division, Ministry of Agriculture, Forestry and Fisheries, Japanese Government 1960-79).

Fish culture started in Japan in the 9th century with carp. In 1928, Sakichi Noami initiated yellowtail culture at Adoike,

Kagawa Prefecture. Before this time, there were many short-term fish farms. In these, anchovy were held as bait for skipjack fishing, and the red sea bream and other fishes were maintained.

Noami chose yellowtail of the many kinds of fishes and selected Adoike as the first location for yellowtail culture for the following reasons: 1) Young yellowtail bring a high price at the Osaka-Kyoto marketing area. Areas of "hamachi," "fukura," and "buri" consumption are shown in Figure 2. 2) In addition to having good culture characteristics, yellowtail is considered a "lucky" fish. Table 1 gives the names of this fish at each growth stage. 3) Juveniles measuring 5 to 150 mm ("mojyako") are found near

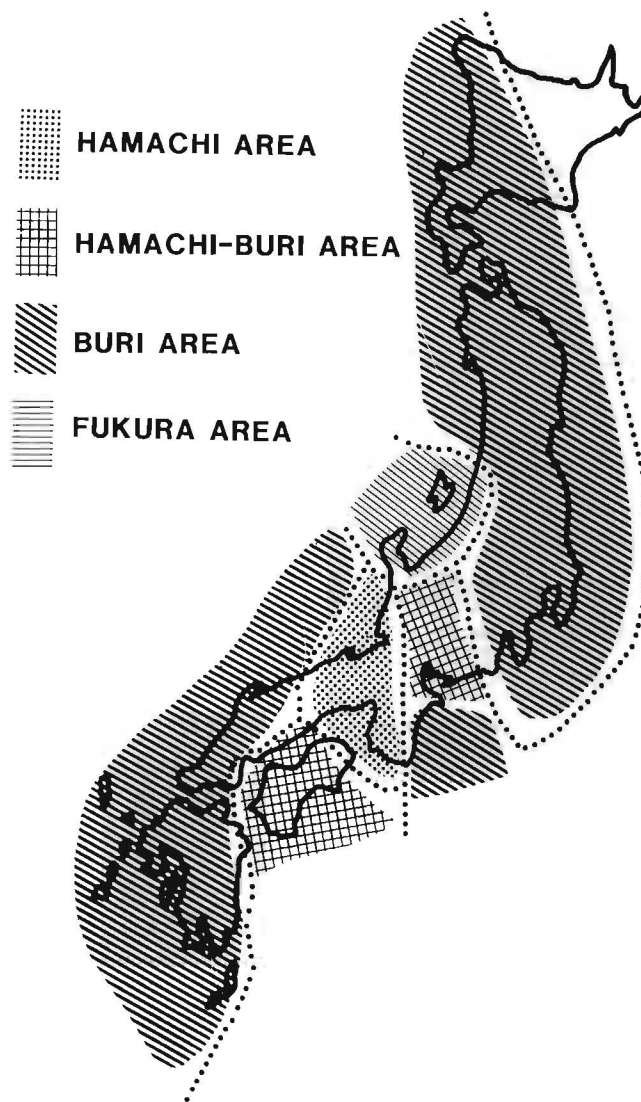

Figure 2.—Areas of hamachi, fukura, and buri consumption.

¹Nansei Regional Fisheries Research Laboratory, Ohno-cho, Saeki-gun, Hiroshima Prefecture, Japan 739-04.

Table 1.—Name changes of growing yellowtail.

Body length (cm)						80	90
	0-10	20	30	40		(2 yr old)	(3 or 5 yr old)
Common and local names	Mojyako Abuko	Wakana Yazu Hideriko	Hamachi Wakanago Wakashi Fukura Tsubasu	Inada Ao Aoko Yazo	Warasa Warasaba Megiro Hanagiyo	Buri Doburi	

floating seaweeds and can be collected easily with nets. A map of the moiyako collecting areas is shown in Figure 3. 4) After the moiyako stage, the feeding habits of yellowtail change from eating crustaceans to fish. Cannibalism and biting increase the frequency of injury and it is estimated that 11 to 20% of the population are affected. However, cannibalism is useful when feeding dead fish

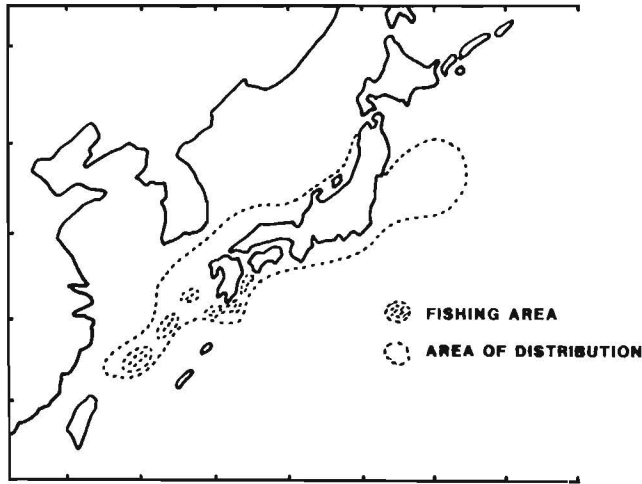

Figure 3.—Yellowtail seed collecting sites.

Table 2.—Some biological characteristics of cultured yellowtail, *Seriola quinqueradiata*.

Distribution	Pacific Ocean and Japan Sea	
Optimum water temperature	12°-28°C	
Biological minimum size	4-5 kg (body weight)	
Fecundity	5-30 × 10 ⁵	
Period of embryonic development (fertilization to hatch out)	48-75 h (18°-23°C)	
Egg size	1.25 mm (floating egg)	
Critical size in food change	40 mm (BL), 1.0 g (BW)	
Daily feeding ratio	30 g (BW) : 60%	1,000 g : 7%
	100 g : 28%	1,400 g : 4%
	150 g : 18%	
	500 g : 12%	
	700 g : 10%	
Growth rate	10-20 g (BW) : 10% (per day)	
	400-500 g : 22%	
	1,000 g : 1%	
	2,000 g : 0.5-0.8%	
Oxygen consumption	360-500 ml O/kg per h	

to captive fish. 5) There were many fish holding ponds along the coast of the Seto Inland Sea, and local fish growers were experienced in fish husbandry. Noami was one of the pioneers in this field. 6) The biological characteristics of yellowtail are useful in culture. Table 2 shows some of the more important characteristics.

Hamachi culture started in 1928 but, unfortunately, did not advance substantially for 20 yr.

ADVANCEMENT OF YELLOWTAIL CULTURE

After the end of World War II, many restrictive regulations were rescinded and hamachi culture developed rapidly. The number of culture areas expanded considerably. However, the amount of yellowtail caught by fishing boats stayed the same — about 30,000 to 40,000 tons. Weights of cultured and captured yellowtail are shown in Figure 4. Despite technical and economic

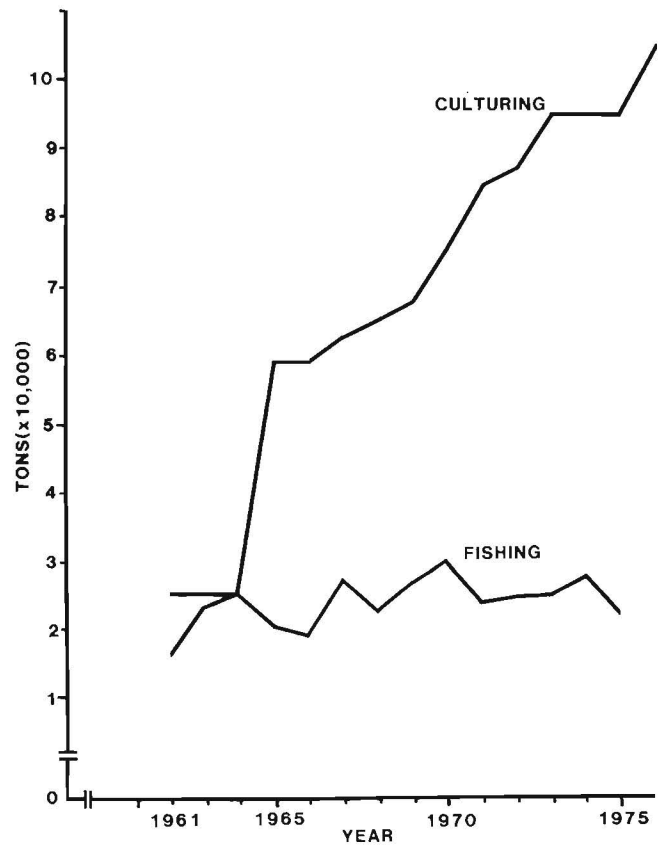

Figure 4.—Weights (tons) of cultured and wild yellowtail from 1961 to 1976.

difficulties, the yellowtail culture industry has advanced. The expansion of hamachi culture is shown in Figure 5. (Yagi 1974.)

The main reasons for the advancement of hamachi culture are 1) economics, 2) techniques, and 3) the ability and determination of fish culturists.

Economic Factors

The decrease in the availability of desirable fish species is shown in Figure 6, and the changes in prices of feed and cultured fish are shown in Figure 7. Fisheries economists define the ratio

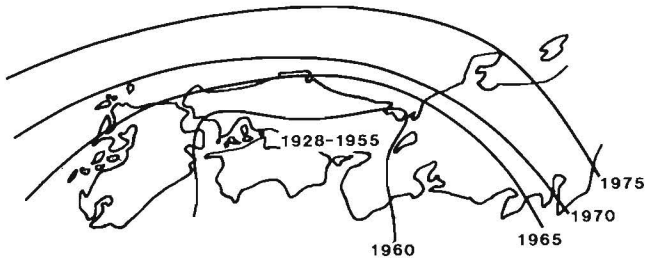

Figure 5.—Expansion of yellowtail culturing areas from 1928 to 1975 in Japan.

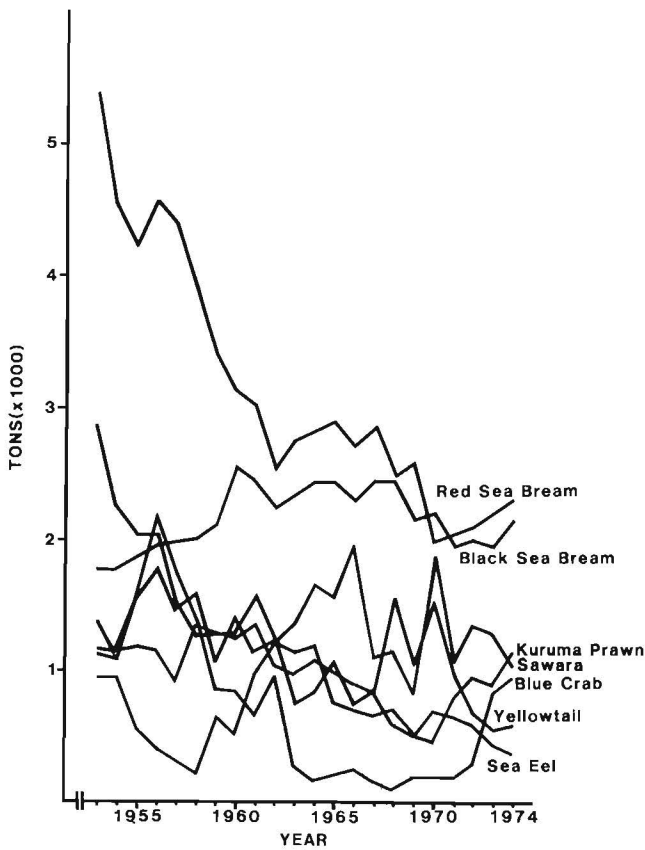

Figure 6.—Changes in the annual production of wild marine fish and shellfish in Seto Inland Sea from 1953 to 1974.

in price of feed to cultured fish as an *R*-value. *R*-values in hamachi culture are consistently 11 or 13. Hamachi culture is unprofitable if growers cannot obtain feed fish at a price which is 1/11 or 1/13 of the price of cultured hamachi.

Production costs of the average commercial hamachi grower are as follows:

juveniles	2 to 30%
feed	30 to 70%
labor	10 to 30%
equipment	5 to 20%
all other costs	5 to 20%

Generally, growers pay particular attention to the prices of juveniles, feed, and marketable adults.

The development of yellowtail culture has proceeded in four stages. The first stage, early development, occurred from 1928 to

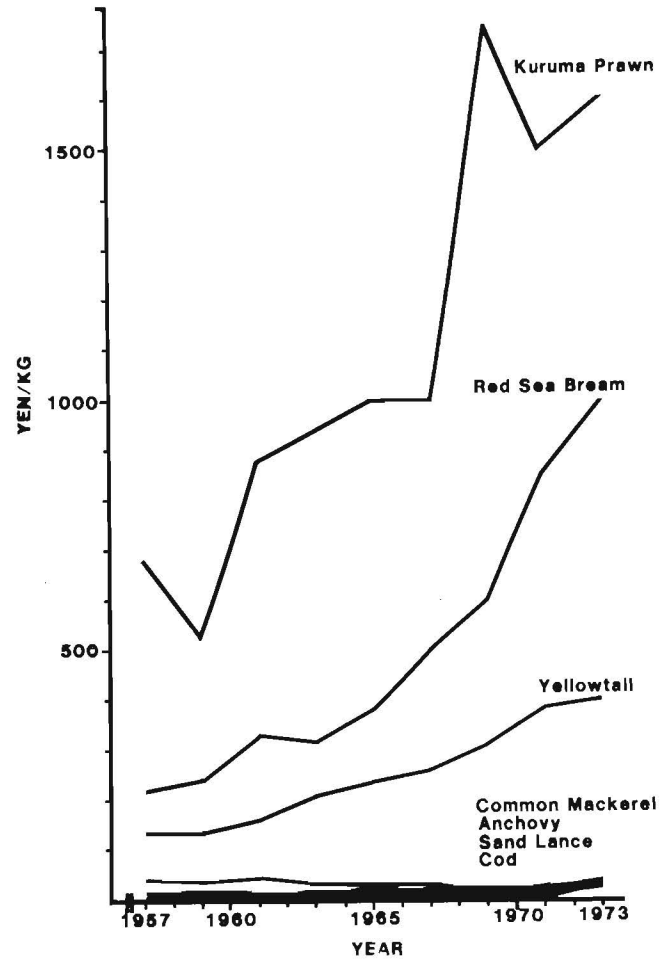

Figure 7.—Prices of feed fish and highly graded cultured fish and shellfish.

1956. The second stage, from 1957 to 1967, was characterized by sudden growth. During this period, floating net cages were developed and suitable areas were used to culture yellowtail. Two infectious diseases, nocardiosis and pasteurellosis (bacterial tuberculosis), appeared. The third stage, which began in 1968, was characterized by long-term culture of yellowtail for production of "buri" (larger than 3.5-4 kg in body weight). During this period, the culture of buri increased. By the end of 1974, cultured buri and hamachi could be found in the public fish markets of most cities. Culture methods and materials have changed considerably.

Technical Factors

Techniques of yellowtail culture have changed. For example, mojayako were 10-15 cm in body length in 1964 and 1965; at present, most are 1.5-2.5 cm in length. However, the survival rate of the latter is two to three times higher than that of the former. Higher survival is possible because juveniles are fed fish meat, and drugs, antibiotics, and vitamins are used. Also, treatment of cultured yellowtail to prevent vibriosis and other diseases has been developed (Fig. 8).

Ability and Determination of Fish Culturists

Generally, fish culturists in Japan are highly competent. Pioneer fish culturists belonged to the social and economic middle

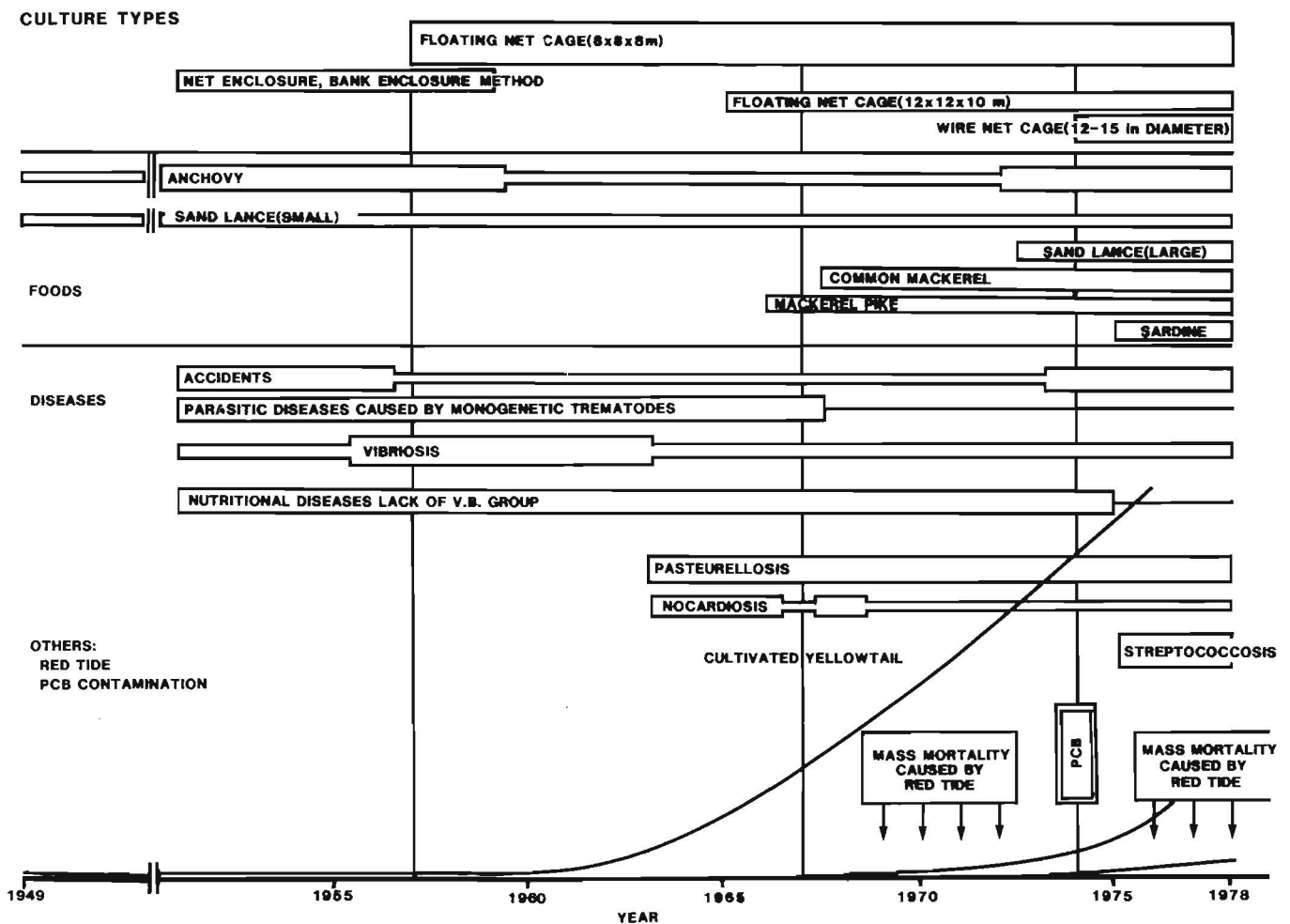

Figure 8.—Problems related to the development of hamachi culture.

class. Now, most of their successors have graduated from fishery high schools or universities. Fish culturists are determined to be successful since the quality of their lives has improved substantially since they started yellowtail culture.

PRESENT STATUS AND PROBLEMS OF YELLOWTAIL CULTURE

Today, hamachi culture has been developed along a major portion of the coast of Japan. Some figures relevant to yellowtail culture in 1977 are as follows:

- 1) collecting and juvenile production farms: 82 (200 persons)
- 2) number of juveniles: 18 million
- 3) commercial yellowtail farms: 3,809 (11,222 persons)
- 4) area: 5,431 km²
- 5) yield (weight per square meter): about 20 kg/m²
- 6) feed fish consumed: 10 million tons
- 7) number of feed fish: 82 million
- 8) yield of cultured yellowtail: 101,618 tons (yellowtail account for about 95% by weight of the cultured fishes).

Problems in yellowtail culture include 1) a stable supply of juveniles, 2) pollution and self-contamination from metabolic products and feed, 3) losses from disease, and 4) shortage of feed fish.

Juveniles

Today, about 50 million juveniles are collected per year, about 10-25% of the yellowtail juvenile population. Collecting juveniles may become more difficult, and their price may rise yearly. These difficulties will press for the hatchery production of juveniles.

Pollution and Self-Contamination

Pollution from industrial wastes and sewage in the Seto Inland Sea is one of the most typical examples, and pollution in yellowtail aquaculture areas is another type, eutrophication. Pollution causes eutrophication which causes red tides and the accumulation of some heavy metals in fishes. Self-contamination by feeding yellowtail is shown in Figure 9. Mass mortalities of cultured yellowtail caused by lack of oxygen in the water occur when there is much self-contamination.

Losses From Disease

Losses caused by diseases of cultured yellowtail in 1972 are shown in Table 3. The value of the losses in 1972 was about 600 million yen. Losses from diseases have increased. At present, 25-30 diseases of cultured yellowtail are known; nocardiosis, pasteurellosis, and streptococcosis are the most serious. The

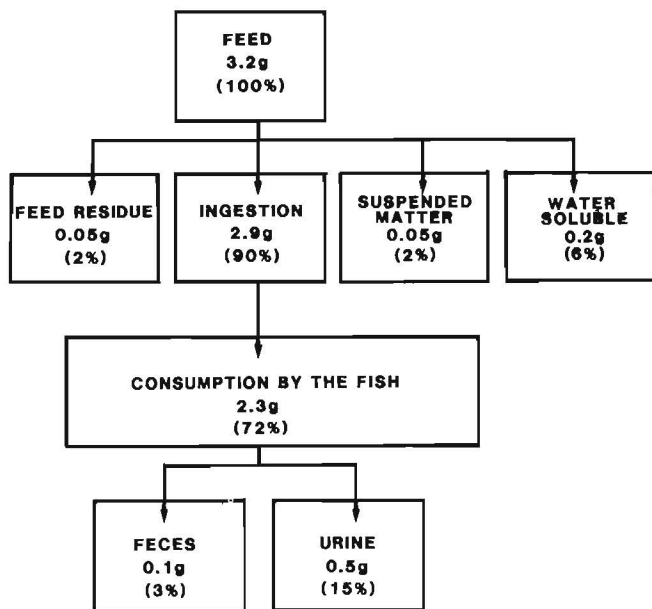

Figure 9.—Partitioning of "self contamination" (as nitrogen content).

Table 3.—Losses from disease in 1972.

Disease	Loss (× 1,000 yen)
Pasteurellosis	518,000
Nocardiosis	4,400
Vibriosis	6,000
Microsporidiosis	8,200
Dropsy	0
Lymphocystis	100
Nutritional disease	50,800
Mass mortality from red tide	2,800
Others	4,500
Total	594,800

geographic distribution of these three diseases is shown in Figures 10, 11, and 12.

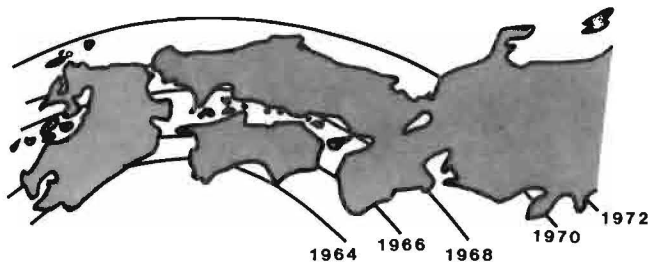

Figure 10.—Distribution and expansion of pasteurellosis from 1964 to 1972.

Availability of Feed Fishes

Fishes usable as feed are listed in Figure 8. Today, obtaining and keeping feed fishes for yellowtail culture is not very difficult, but may become more difficult each year.

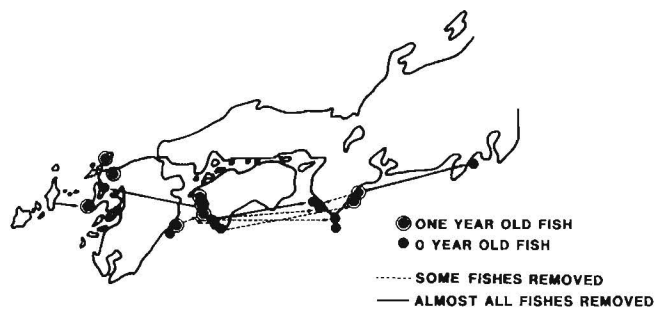

Figure 11.—Reported epizootics related to transportation of live fish with nocardiosis in 1972.



Figure 12.—Distribution of streptococcosis in 1975.

FUTURE POTENTIAL OF YELLOWTAIL CULTURE

In the first meeting of the UJNR Aquaculture Panel in 1971, John Glude reported on marine fish culture in Japan. He discussed some future problems in yellowtail culture in his report (1974): "Production from yellowtail farming is limited to approximately the present level because of government restriction on the number of young fish which can be taken from coastal waters." The level at that time amounted to only 30,000 tons, and the number of collected juveniles was 10-30 million. At present, the number of yellowtail juveniles caught along the coast of Japan is estimated at 200 million annually. Half of the juvenile population now has been used. The price of cultured yellowtail has remained the same (1,000-1,200 yen/kg) for the past 3 yr in spite of two- to three-fold increases in the cost of juveniles.

Furthermore, areas suitable for yellowtail culture have been completely used. It is difficult to predict the potential of yellowtail culture, but it is unlikely that marine fish culture, including yellowtail, will ever fail in this country.

The potential of yellowtail and other cultured fishes is as follows:

- 1) Production of yellowtail will reach 150,000 tons within a few years and will stay at that level.
- 2) Many kinds of fishes will be cultured.
- 3) Production of yellowtail juveniles by artificial fertilization will begin in a few years.
- 4) The weight of culture marine fishes will reach 250,000 tons.
- 5) Halibut culture will grow rapidly.

LITERATURE CITED

- GLUDE, J. B.
1974. Marine fish culture in Japan. *In* Proceedings of the First U.S.-Japan Meeting on Aquaculture at Tokyo, Japan, October 18-19, 1971, p. 115-121. U.S. Dep. Commer., NOAA Tech. Rep. NMFS CIRC-388.
- STATISTICS and SURVEY DIVISION, MINISTRY of AGRICULTURE, FORESTRY and FISHERIES, JAPANESE GOVERNMENT.
1960-79. Annual report of catch statistics on fishery and aquaculture, 1960-1979.
- YAGI, T.
1974. A study on the market system of the coastal fisheries landing 1-45.

Present Status of Red Sea Bream in Japan

RYO OKAMOTO¹

INTRODUCTION

In Japan, the total production of marine fishes in aquaculture reached 110,000 t in 1976. This was about 1% of the total fishery production and most of it was yellowtail. Recently, the production of sea bream in aquaculture has increased. Sea bream was not independently mentioned in the fishery statistics until 1969.

The reasons for the increase in sea bream production are summarized as follows: 1) In 1970, the production of yellowtail in culture was 30,000-40,000 t. This met the demand, causing a decline in price. 2) The capture of young yellowtail "Mojako" in the sea was estimated to be 50-60 million (now more than 100 million). We became anxious about its influence on the fishery and natural resources of yellowtail. 3) The culture of red sea bream was profitable in view of its growth, survival rate, and marketability, based on experiments on the coast of Seto Inland Sea and Kyushu, the southeast region of Japan. 4) Sea bream is more resistant than yellowtail to unfavorable environmental conditions, such as "red tide." 5) Artificial mass seedling production systems of sea bream had already been established. Yellowtail culture still depends on natural seedling production. Since we start with seedlings in marine aquaculture, it is important whether we can produce them artificially.

Imai (1970)² defined "through culture" as the system of artificial and intentional production from egg to adult. Red and black sea bream cultures are already in the stage of "through culture." Culture of yellowtail, yellowjack, horse mackerel, and other fishes are near this stage. The following is a survey of recent techniques and production in the culture of red sea bream in Japan.

RECENT INCREASE OF SEA BREAM CULTURE PRODUCTION IN JAPAN AND ITS SIGNIFICANCE

Most fish culture production has been occupied by yellowtail. Gradually other fishes have been cultured, especially sea bream. Sea bream culture production increased and reached 6,639 t (Fig. 1). This quantity was 700 t more than the natural fishing production of sea bream (red, black, crimson), 5,916 t, in 1976 in the Seto Inland Sea, a known fishing ground for sea bream.

Development of sea bream culture by area and year is shown in Figure 2. In the beginning, these cultures were developed on the west coast of Kyushu Island and the outer coast of Shikoku Island. Because plenty of natural seedlings were supplied and growth was better in warmer conditions, they were able to pass the winter season in these areas. With the establishment of the artificial seedling supply system, the culture gradually extended to the Seto Inland Sea, the central Pacific coast and the west Japan Sea coast. Table 1 shows the contribution of yellowtail and sea bream to the

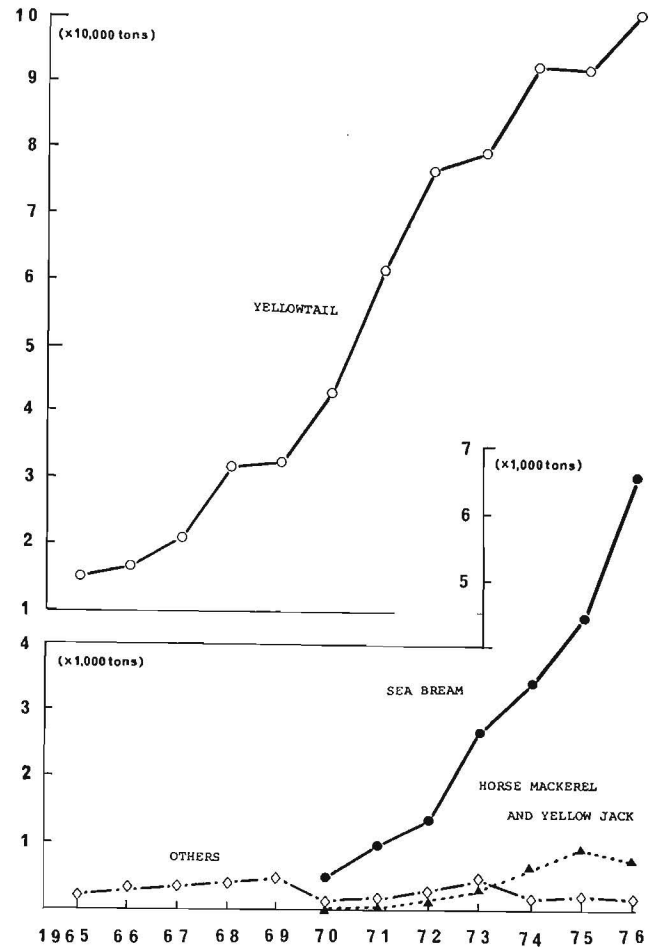

Figure 1.—Annual fish production by mariculture. (Calendar year: seed fish production excepted.)

total aquaculture production of marine fishes. The contribution of sea bream varied from 1.1% (1970) to 6.1% (1976), whereas that of yellowtail decreased by 5.6%. These statistics indicate that the conventional method of aquaculture of marine fishes had been reformed to the system of "through culture." This had a significant effect on the history of technical development of marine fish culture in Japan.

AN OUTLINE OF AQUACULTURE TECHNIQUES IN RED SEA BREAM CULTURE

Seedling Production

Since red sea bream is not only a valuable fish but also has an important association with Japanese customs, research into arti-

¹Nansei Regional Fisheries Research Laboratory, Ohno-cho, Saeki-gun, Hiroshima Prefecture, Japan 739-04.

²No Literature Cited section was supplied by the author.

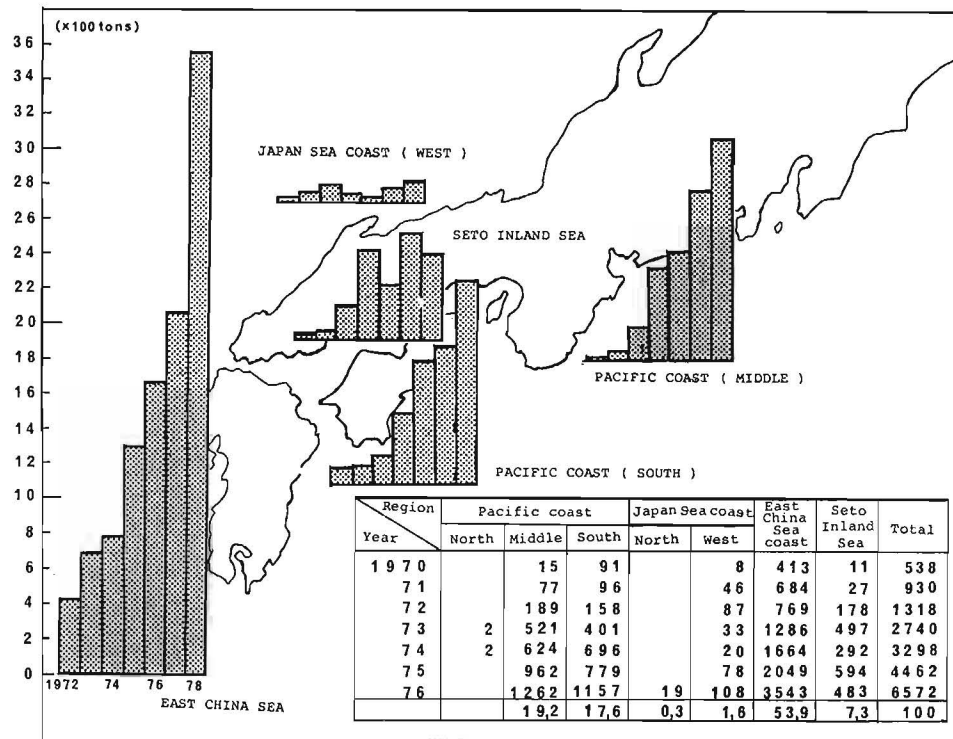

Figure 2.—Annual production of cultured sea bream by region (metric tons).

Table 1.—Production ratio of yellowtail and sea bream in fish culture (%).

Year	Yields of fish culture (t)	Percentage yield of fish culture	
		Yellowtail	Sea bream
1970	43,910	98.6	1.1
1971	62,912	98.1	1.6
1972	78,723	97.7	1.8
1973	83,769	95.8	3.2
1974	97,084	95.5	3.6
1975	97,997	94.2	4.5
1976	109,257	93.0	6.1

ficial seedling production started in 1887. However, mass production research did not begin until 1965. The generation time of this species in the sea is 4 or 5 yr; in "through culture" it is 2 yr at the earliest, or at latest, 3 yr. Fertilized eggs can be collected in floating net cages or culture tanks from cultured spawners in May and June, when water temperature is usually 17°-21°C. After hatching, with larval development, food should be changed from larval bivalves to marine rotifers, then to marine copepods. Minced fish is given 30 d after hatching (12-55 mm in total length).

During the first 20 d, pond water for rearing should be kept stationary, except for aeration, to protect larvae and living food from flowing away. Sudden changes in environmental conditions, such as water temperature, light, and aeration, should be prevented. The accumulation of NH₃, NO₂, and N in the pond originating from larvae and food should be monitored. These often pollute the pond water.

Seedlings for release or culture should be more than 50 mm in total length because they must be able to feed completely on minced fish, protect themselves from predators, and be fit for the environmental conditions of water temperature, water movement

or streaming, and light. At the current technical level, the survival rate at this stage is 20-30%. A seedling is about 80 yen in the market (1978).

Culturing

1) Suitable conditions for a farm

- a. Calmness and slow tide: These conditions are necessary for safety of the cage.
- b. Depth and water exchange: Water depth should be twice that of the cage and water movement should be 5-15 cm/s to avoid a decrease in dissolved oxygen caused by the stagnation of water and the generation of sulfides. Fast stream flows cause the net of the cage to move up, resulting in damage to the fishes inside it.
- c. Water temperature: Between 20° and 28°C, red sea bream has the greatest appetite and shows the fastest growth. Over 29°C, it is active but this temperature easily causes physiological stress. Under 20°C, appetite decreases gradually, and growth is slower. Under 12°C, it scarcely feeds. Under 10°C, weight decreases because it is not feeding and the fish is, consequently, in danger. At 11°C, if the temperature is rising, it begins feeding activity, but if the temperature is falling, it becomes totally inactive. When the temperature falls slowly, it stays alive at 8°C; on the other hand, when the temperature falls rapidly, it dies at 11°C.
- d. Water quality: The inflow of sewage or industrial wastewater must be avoided. Inflow from a river is also undesirable because it causes an extreme drop in salinity. Red tide regions should also be avoided.
- e. Transportation: It should be convenient to carry food and seedlings to the farm.

f. Easy care for general control.

2) Culturing apparatus and capacity

From the early days, banks or nets have been used to divide an inlet or bay. Floating net cages are now used 99% of the time. The rafts or floats, equipped with culture nets (5 m square and deep or 8 m square and 6 m deep), are anchored. As the fish grow, the smaller mesh is replaced by larger mesh. The widespread use of floating net cages owes to their ease of use, low cost, convenience, and high productivity per area. Productivity when using banks is $< 1 \text{ kg/m}^3$; that of nets is $6-7 \text{ kg/m}^3$ when fishes are more than 500 g. In the latter method, when fishes are 3 g, the capacity is about 1 kg/m^3 , at 20 g it is $2-3 \text{ kg/m}^3$, and at 200 g it is $4-5 \text{ kg/m}^3$.

3) Feeding and growth

Recently, advances have been made in the development of the quality of artificial compound food, but this artificial food comprises only 0.5% of the total food consumption. Most of the food consists of minced fish such as anchovy, sand eel, mackerel, and mackerel pike. The daily feeding ratio is 6-8% of the body weight in fish $< 1 \text{ yr}$ -old, 5-6% in 1 yr-olds, and 4-5% in 2 yr-olds during the period when the water temperature is high. The conversion efficiency is 8-10 over the total culture period (Fig. 3).

The growth curve in culture is shown in Figure 4. Cultured red sea bream grow to be 200 g in a year, 600-800 g in 2 yr, and 1-1.2 kg in the third winter. Wild red sea bream need 4-5 yr to reach 1 kg; wild black sea bream grow more slowly.

4) Body coloration

Since early times, red sea bream has been admired and valued for its elegant shape and bright crimson body color, as well as its taste. Though red sea bream has been cultured for a long time, it was not until recently that its culture

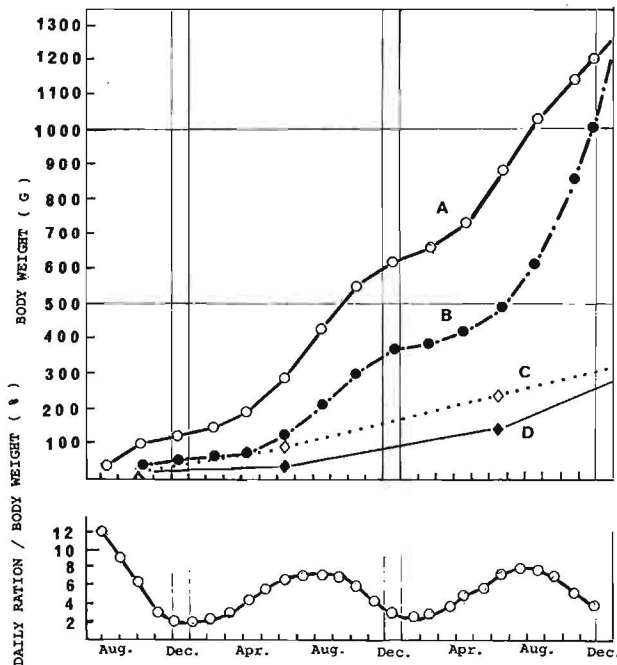

Figure 3.—Growth and daily feeding ratio in cultured red sea bream. A: Kumamoto Prefecture Fishery Experiment Station, 1969; B: Fish farm in Shizuoka Prefecture, 1974; C: Wild population of red sea bream (Mio 1962); D: Wild population of black sea bream (Ohshima 1942).

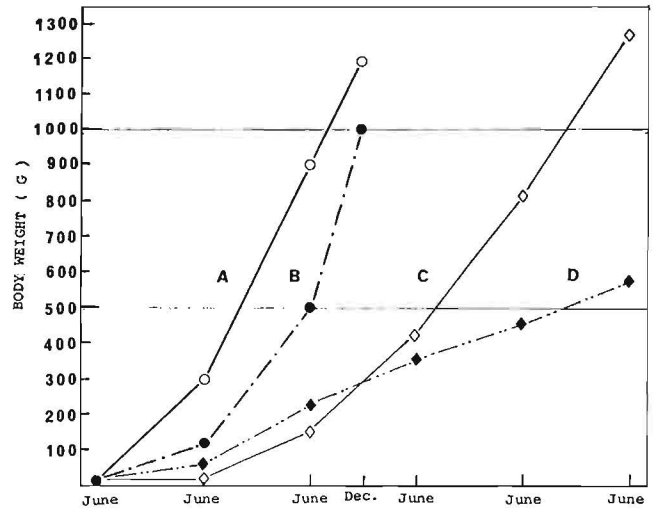

Figure 4.—Growth in cultured and wild sea bream. A: Kumamoto Prefecture Fishery Experiment Station, 1969; B: Fish farm in Shizuoka Prefecture, 1974; C: Wild population of red sea bream (Mio 1962); D: Wild population of black sea bream (Ohshima 1942).

became widespread. One of the reasons for its slow spread was that its color changes from crimson to black. Cultured sea bream that are black have a low market price. Much research has been done on the biochemistry of pigment, coloring, and food on fishes; however, no definite technique to maintain the crimson body color has been developed. Based on breeding experience, the following methods are known to be effective: 1) Use of red shrimp, *Metapeneopsis barbatus* as food, and 2) deepening the cage and shading it from sunlight. The solution to this problem is one of the most important considerations in aquaculture of this species.

5) Disease

With the development of the aquaculture industry of red sea bream, knowledge of various diseases and abnormalities that occur in culture are accumulating. When many fishes are reared over a long period, diseases are apt to occur because of the intensive culture and efficient fattening of the fishes. Today about 10-15 kinds of diseases are known. These include lymphocystis, vibriosis, and some nutritional diseases. *Flexibacter* causes one of the worst infectious diseases.

6) Loss in the process of rearing

Loss is mainly caused by diseases and escapes. Diseases are prevented by proper selection of farm grounds, suitable feeding, and proper density of fishes. Escapes, owing to damage of the cage nets, failure to exchange nets, or flows caused by typhoons, can be prevented by adequate control systems. Currently, the loss of 1 yr-old fish is 2-10%, and that of 2-3 yr-old fish is 1-3%.

CONCLUSION

As mentioned above, "through culture" of red sea bream is well established, though there are still problems with diseases and body color (Fig. 5). These problems may be solved in a few years. However, the culture of red sea bream is done as a sideline compared with that of yellowtail. Culturists are hesitant to begin the monoculture of red sea bream, in spite of its seedling availability,

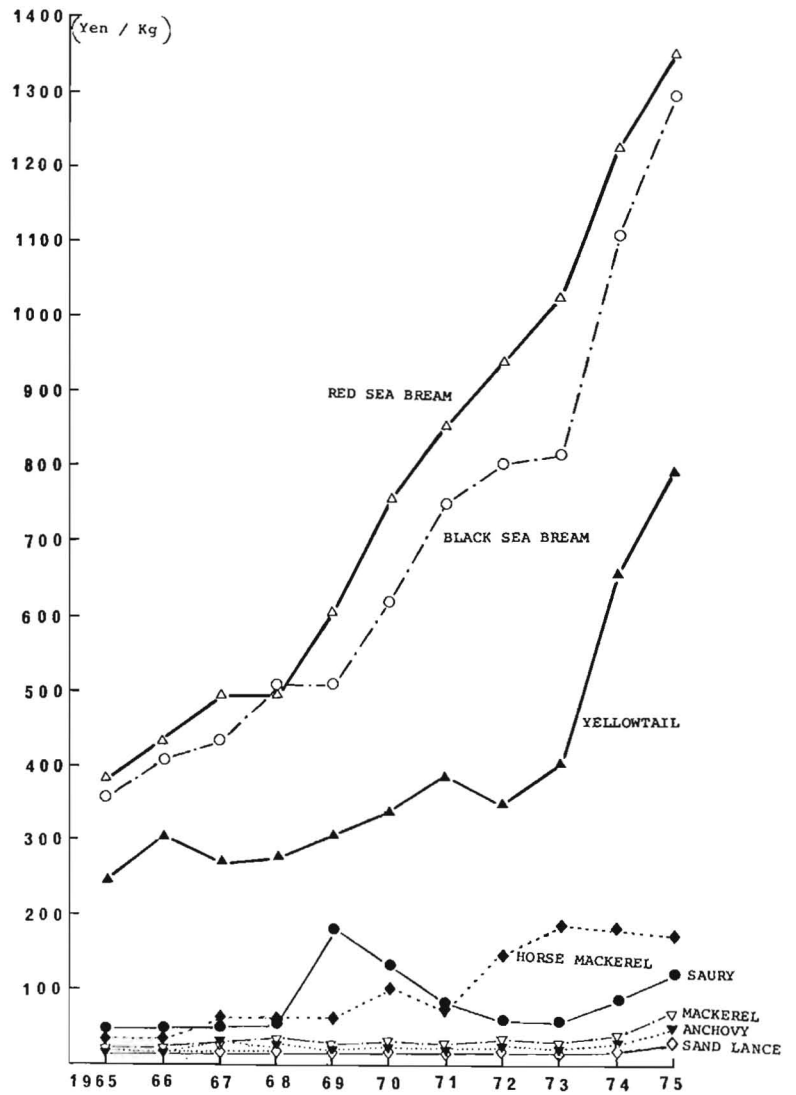

Figure 5.—Price of fresh fish at fish markets. “Live fish,” in which condition the cultured fish is usually marketed, is priced higher than fresh fish. For example, the prices of cultured red sea bream and yellowtail in December 1975 (Hiroshima fish market) were 1,800-2,000 and 1,000-12,000 yen/kg, respectively.

strength, yields, and prices as compared with yellowtail. An important factor in this hesitation is the uncertainty in the future that, when culture production of red sea bream is 50,000-100,000

t, it will remain a valuable fish. The establishment of culture techniques and management policies which take into account the particularities of this species are now needed.

Practical Problems in Finfish Culture in Kochi Prefecture

MICHIKO TANIGUCHI¹

COMPONENTS OF MAJOR FISHERIES IN KOCHI PREFECTURE

Kochi Prefecture is located on the southern part of Shikoku Island. The climate of the district is generally temperate throughout the year, but the district is subject to frequent typhoons during the summer and suffers severe disasters. Kochi is also affected by the Black Current running off Shikoku Island (Fig. 1), so that the fisheries of this district have depended mainly on migratory fishes, such as skipjack tuna, frigate mackerel, common mackerel, and horse mackerel. The major fisheries and their yields in Kochi are shown in Figures 2 and 3. The yield of marine fish culture is third in amount, and second in value.

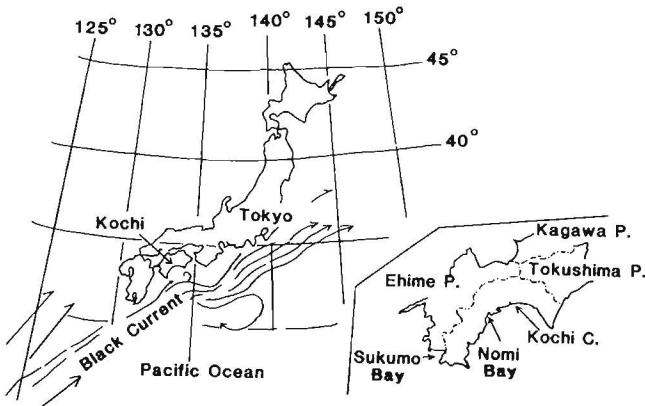

Figure 1.—Location of Kochi Prefecture and its marine culture grounds.

COMPONENTS AND YIELDS OF FISH CULTURE

The components and yields of marine fish culture are summarized in Table 1. Marine fish culture is primarily represented by that of yellowtail, *Seriola quinqueradiata*; the amberjack, *Seriola purpurascens*, and the red sea bream, *Pagrus major*, have minor roles in fish culture. Sukumo City, in the western part of Kochi Prefecture, is the most important city in the yield of cultured fish; Susaki City, in the middle part of Kochi Prefecture, is second in the production of cultured fish. The products of both cities depend mostly on the culture grounds of Sukumo Bay (Sukumo City) and Nomi Bay (Susaki City), respectively.

Eel culture has been performed mainly in open fields in the middle part of Kochi Prefecture — Nankoku City, Kochi City,

¹Kochi Prefectural Fisheries Experiment Station, Uranouchi, Susaki, Kochi, Japan.

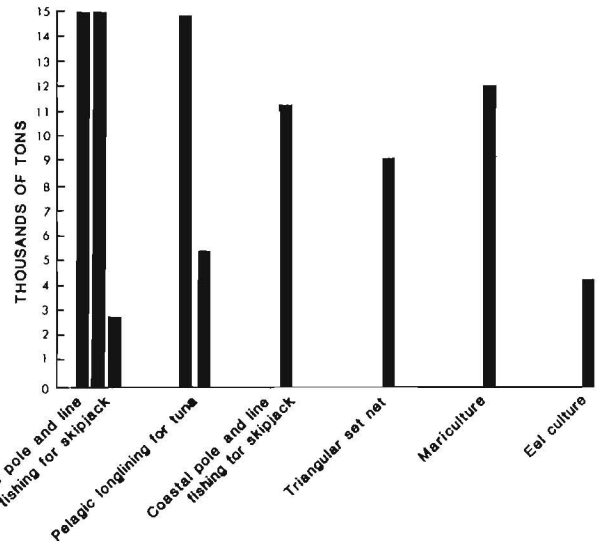

Figure 2.—Amount of products for the respective fisheries in Kochi Prefecture. Multiple bars are additive.

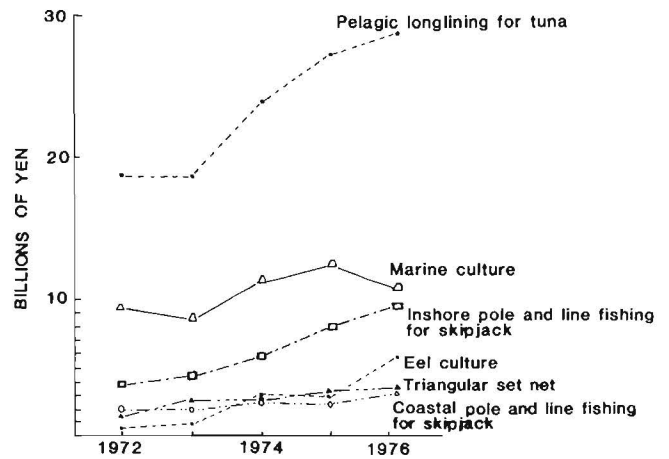

Figure 3.—Yield for the respective fisheries in Kochi Prefecture.

Tosa City, and other areas. About 4,000 tons of products, worth 5 billion yen, are produced annually.

METHODS OF EEL CULTURE IN KOCHI PREFECTURE

Recently, a new culture method has been developed and is replacing the earlier method. This method, extensively used in Kochi Prefecture, is technically derived from the horticulture of

Table 1.—Yields of marine fish culture.

Localities	Number of culturists	Area under cultivation (m ²)	Yields (tons)				
			Yellow-tail	Amber-jack	Common horse mackerel	Yellow-jack	Red sea bream
Tosa	10	4,894	263	—	—	—	—
Susaki	307	55,574	2,099	915	—	—	63
Nakatosa	6	1,929	192	—	—	—	—
Kubokawa	1	1,090	137	—	—	—	—
Nakamura	—	—	—	—	—	—	—
Tosashimizu	5	2,821	355	—	—	—	8
Otsuki	181	46,890	2,214	2	2	1	84
Sukumo	196	82,464	4,663	—	—	—	—

Spanish paprika and cucumber using a polyvinyl sheet house and a boiler. The characteristic of this new method, "the polyvinyl-sheet-pond method," is that a sheet-pond is set in a polyvinyl sheet house which keeps the water, heated by a boiler, at about 25°C. Since this culturing method was designed in 1974 at Kochi Prefecture, culture yields have increased rapidly.

The structure of this equipment is shown in Figure 4. The circulating water, heated by the boiler, runs through a metallic pipe

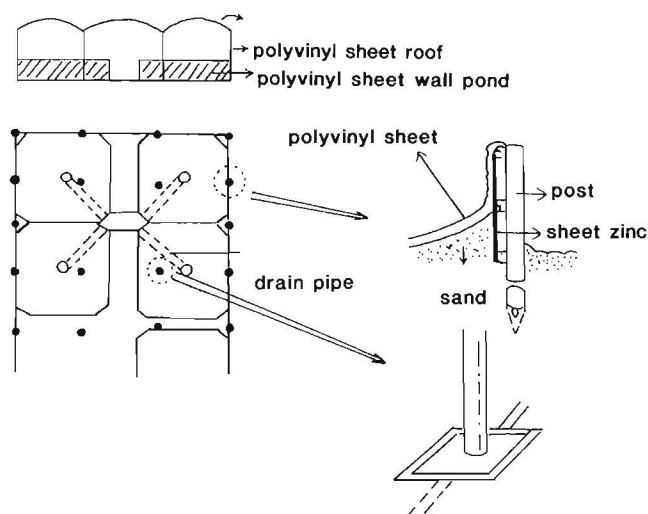

Figure 4.—Schematic figure of the polyvinyl sheet pond.

set in the polyvinyl sheet pond, so that the pond water is warmed indirectly. This method is remarkably different from the earlier Shizuoka method. After the elvers are caught and put into the pond in early spring, the water is immediately heated and maintained at a temperature of about 25°C. To control growth of green algae, the pond water must be changed once a day.

The advantages of this method are the efficient and rapid growth of eels, the decrease in mortality of elvers, and the prevention of disease in winter and early spring. The disadvantage of this method is that some problems, e.g., breakdowns in electric current or thermoregulatory problems, can cause serious damage and even death of numerous eels. Also, diseases which appear in warmer seasons arise in all seasons. Another problem with this new method is that the profit of the culturist decreases from year to year because expenses for materials, fuel, and electricity increase in relation to the current economic conditions.

MARINE FISH CULTURE

Marine fish culture is divided into the following three types based on the characteristics of the culture grounds: The inner bay type, the outer bay type, and the offshore type. These characteristics are summarized in Table 2 and their crawl (an enclosure in shallow waters — as for confining lobsters) structures are shown in Figures 5, 6, and 7. The daily task of rearing fish is easier and the construction of the floating nets is less expensive in the inner bay type as compared with the other two types. The problem with the inner bay type, however, is that pollution of the water of the culture ground occurs in a short time. Therefore, fish culture of

Table 2.—Characteristics for each type of marine fish culture.

Characteristics	Culture ground		
	Inner bay	Outer bay	Offshore
Maximum velocity of current	25 cm/s	50 cm/s	100 cm/s
Maximum wave height	0.3 m	2 m	8 m
Wave length	5-10 m	22-30 m	150-200 m
Maximum degree in Beaufort's wind scale	1-2	3	8
Maximum wind velocity	—	15 cm/s	30 cm/s
Distance of storm in typhoon	—	20 km	∞
System	floating	submerging	floating and submerging
Material of frame	bamboo and iron	synthetic fiber (long line)	iron
Material of netting crawl or cage	synthetic fiber and wire	synthetic fiber "only"	synthetic fiber and wire

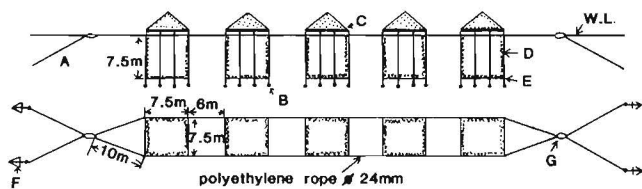

Figure 5.—Yellowtail mariculture facilities in embaymental farming ground. A, polyethylene rope, ϕ 24 mm, n 3; B, stone, 7-8 kg; C, bamboo frame; D, polyethylene fiber, 400^d/40, 7 knot; E, frame line, ϕ 10 mm; F, anchor 50 kg; G, styrol float, ϕ 56 cm, length 90 cm, buoyancy 200 kg.

this type is continued only in areas where water exchange in the culture ground is comparatively good. The inner bay type is used in fish culture in Nomi Bay of Susaki City.

The outer bay type is used in Sukumo Bay where fish culture has been carried out extensively over the last 7 yr. Crawl construction of this type is well adapted to use in Sukumo Bay because of its oceanographic features. In this bay, we cannot use metallic frames and cages which are supposed to be physically strong, because the wave length is too short to move the structures smoothly in stormy weather. Crawl constructions designed for Sukumo Bay (Fig. 6) lasted for a long time without accident despite the occurrence of typhoons. The disadvantages of the outer bay type are summarized as follows: 1) This type is comparatively expensive, because it requires many materials and a large boat for rearing fish, 2) it takes much time to go to the rearing point from the base point because both points are usually distant, and 3) it is difficult to go to the rearing point in bad weather. It is also difficult to take care of and observe the condition of reared fishes because the net cages are sunk down about 2 or 3 m.

In the offshore type, various considerations are required in planning the construction of the cage. The most important points involve the mooring method and attaining the appropriate

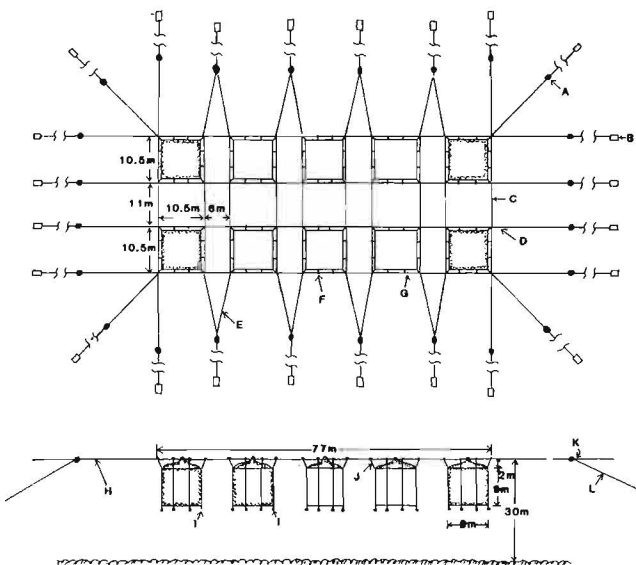

Figure 6.—Structure of outer bay type mariculture facilities. A, styrol float, buoyancy 200 kg; B, concrete block 2.5 t; C, polyethylene rope, ϕ 25 mm; D, polyethylene rope, ϕ 30 mm, length 20 m; E, polyethylene rope, ϕ 25 mm, length 15 m; F, small float, buoyancy 1.5 kg; G, polyethylene rope, ϕ 16 mm; H, polyethylene rope, ϕ 30 mm, length 20 m; I, sand bag, 20 kg; J, polyethylene rope, ϕ 16 mm; K, mooring buoy; L, polyethylene rope, ϕ 25 mm, length 90 m.

buoyancy for construction. The best mooring method of the offshore type is to moor it directly to the two parallel long lines. The float buoyancy of the mooring lines and the net cages should be at the minimum, since the respective floats have a buffer action. An example of this type of structure is given in Figure 7. In using the polyethylene net, the structure is almost the same as in the outer bay type, but a heavier sinker and more burly rope must be used. It is also important to protect the fishes from sharks and puffers. This type of structure has been tested in the culture of bluefin tuna at sea by the staff of the Kochi Prefectural Experimental Station since 1976. Recently, "the iron-frame sinker" and "the double-bottomed-net" were designed; the former is effective in obtaining the maximum volume of net crawl, and the latter is effective in protecting the fishes from sharks and other predators.

In the offshore type, a high rate of water exchange maintains the water quality in the cage. The disadvantage of this type is that construction materials are more expensive than in the other types. Also, the risk of typhoon damage is strongest in this type. Consequently, the offshore type has not spread among fish culturists. However, these improved structures have lasted for several years without any serious accidents despite the occurrence of typhoons in Nuno, Tei, and Sukumo.

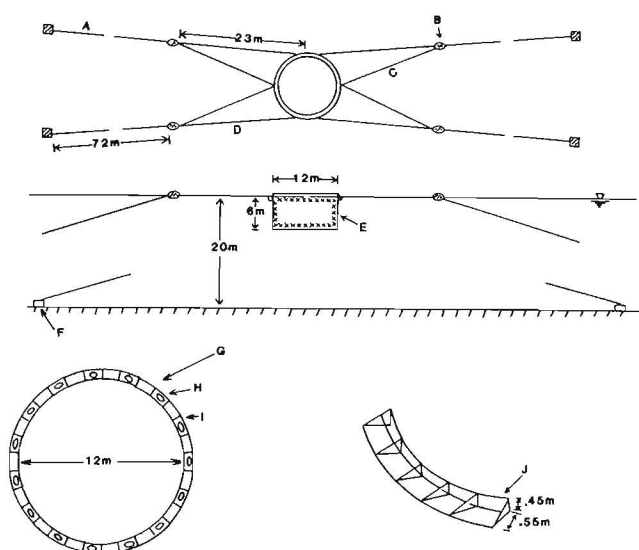

Figure 7.—Structure of offshore type mariculture facilities. A, polyethylene rope, ϕ 65 mm; B, styrol float, buoyancy 200 kg; C, polyethylene rope, ϕ 24 mm; D, polyethylene rope, ϕ 48 mm; E, wire net, ϕ 4.2 mm, length 6.5 cm; F, concrete block 7 t; G, iron frame (six set combined); H, styrol float, buoyancy 200 kg; I, welded part; J, steel galvanized pipe, ϕ 50 mm.

SOCIAL PROBLEMS IN MARINE FISH CULTURE

Marine fish culture is controlled by licensing. Licenses are usually given to fisheries cooperatives, but are seldom given to fisheries producers' cooperatives. The fisheries cooperatives are not directly involved in fish culture, but each member of the association does it independently under licenses which restrict the number of fishes reared, the number and the setting places of the crawls and cages, and so on. The prefectural authorities who are responsible for total management have the viewpoint that the overproduction of yellowtail should be prevented by limiting the number of cultured fishes for each fisheries cooperative. They also

encourage each culturist to change the fish species. Their policy strives to stabilize business, prevent water pollution, and preserve natural stocks of yellowtail which had been caught during the early stages of fish culture.

There are a few problems in marine fish culture. Water pollution of the culture ground is the most serious one in the inner bay type. In recent years, red tide and oxygen deficient water have appeared frequently in warm seasons. Therefore, cultivation in these places should be stopped. Fish culturists now wish to move to the outer bay or offshore, although this is difficult to coordinate with other fisheries. The staff at my Institute is doing experiments to refresh culture ground environments. Part of the present fish culture will have to change to other fisheries such as fish farming without feeding.

A serious economic problem is profitability. Fish culturists are at a disadvantage because of the low price of their products and the high costs of construction and food for the fish. To solve this problem, one must examine whether other species are suitable for cultivation.

Fish disease is another serious problem for the fish culturist. Major diseases of cultured fishes are pasteurellosis (pseudotuber-

culosis), nocardial infection, and *Streptococcus* infection. These diseases cause great economic loss for the culturist; there is no practical, effective medicine for nocardial and *Streptococcus* infections. A study of these diseases has continued since 1971 to prevent damage from these diseases at my experimental station. Since diseases of cultured fish have become more complicated from year to year, the culturist should have the ability to make the primary diagnosis competently. Culturists are educated about diseases and taught some routine tests, including the medicine tolerance test, of pathogenic bacteria at fishery service stations that are located in several districts of Kochi Prefecture. The purpose of these stations is to provide executive and technical guidance. The staffs at these stations keep in close contact with culturists in developing their plans for dealing with fish diseases.

Although many problems exist in marine fish culture and eel culture, these aquacultures will maintain a major position in the fisheries of Kochi Prefecture from ecological, biological, and economic standpoints.

The author wishes to thank the staff of the Kochi Prefectural Fisheries Experiment Station for their helpful suggestions.

Maturation and Spawning of Marine Finfish¹

C. R. ARNOLD²

INTRODUCTION

Laboratory maintenance and spawning of important marine fish species has been necessary to gather life history and reproductive information. Species whose native stocks have been depleted by natural and/or man-made changes in the environment or those species that have a potential for mariculture (Johnson et al. 1977) have been among those maintained in a laboratory situation to obtain this information.

The bulk of early information on reproduction has been attained from gravid fish collected and brought to laboratories during the spawning season. For example, salmon and striped bass have been kept in tanks and manually stripped of eggs and milt (Stevens 1966; Bardach et al. 1972). More recently, gonadal and/or pituitary hormone injections have been used in conjunction with stripping. However, with this technique many of the eggs were voided as immature oocytes in various stages of development. Hormonal injections are valuable in inducing spawning for those species which release all their eggs in a single spawn (one time spawners). However, if the fish is a continuous spawner (spawns over a long time period with many separate spawns) the use of hormone injections usually causes all the eggs to be released, only a small percentage of which are at a stage which can be fertilized. Often the brood fish die or gonadal tissue is permanently damaged from these hormone and stripping procedures. Variations in this basic technique in which the stripping process is eliminated have also been reported; and gravid fish injected with hormones have been induced to spawn naturally in a laboratory situation (Kuo et al. 1974; Hoff et al. 1977; Garza et al. 1978).

Research on the life history of fish depends on a continuous and predictable supply of eggs and milt. Methods involving hormone injections do not always ensure an adequate supply of gametes. But, this earlier research with salmon, striped bass, and other species provided a number of techniques to collect fish, treat diseases, control water quality, and feed fish in open and closed systems (Lasker and Vlymen 1969; Spotte 1970; Bardach et al. 1972).

Pickford and Atz (1957) and Hoar (1959) recognized that temperature and photoperiod were two of the most important spawning stimuli in temperate and subtemperate fish species. Temperature changes are most important for maturation in some temperate species while in other species photoperiod plays the major role (Kuo et al. 1974). Generally, in spring spawners, a rise in temperature and an increase in photoperiod induces maturation and the inverse is true for the fall spawners. These increases or decreases in temperature and photoperiod must be determined with each species before laboratory spawning can occur.

Another critical limit in spring or fall spawners is an obligatory refractory (winter) period that must be met and passed through

before laboratory spawning can occur. This period is usually of a few months in duration in temperate and subtemperate fish but may be very long in subtropical species. This period also varies for one time spawners and continuous spawners. Once the refractory period and the necessary lengths and rates of change from each of the four annual seasons to another are determined, temperature and photoperiod control should induce spawning and provide a large volume of usable eggs and milt.

Temperature and photoperiod control, with knowledge of the refractory period and seasonal limits, may permit a decrease in the annual cycling time between spawns making more than one spawn per year possible.

Once the temperature and photoperiod for a species have been determined, spawning may be delayed or prolonged by changing the water temperature a few degrees up or down from the optimum. This technique prolongs the spawning season and produces eggs on demand. Care must be exercised with the rate and timing of water temperature changes to prevent resorption of eggs.

Egg and milt production may be maximized with continuous spawners by "holding" the temperature and photoperiod constant when a species has started spawning. A species may be spawned more than 12 consecutive months when spawning temperature and photoperiod are set in this manner (Arnold et al. 1976).

METHODS AND MATERIALS

Fish utilized for spawning experiments were taken near Port Aransas, Tex., from estuarine and gulf populations of each species. Red drum, *Sciaenops ocellata*, were taken by hook-and-line and beach seine. Spotted seatrout, *Cynoscion nebulosus*, and red snapper, *Lutjanus campechanus*, were collected by hook-and-line. Southern flounder, *Paralichthys lethostigma*, were taken by hook-and-line and trammel net. Red drum and southern flounder were taken during their fall spawning period and spotted seatrout in the early spring season. Immature red snappers taken in early fall were placed in the spawning tank. The snapper tank was covered with nylon netting to prevent fish from jumping out of the tank.

Red drum (750 mm TL), spotted trout (356 mm TL), and southern flounder (males 254 mm TL, females 305 mm TL) were kept as brood fish. Fish were transferred to the laboratory in fiber glass tanks (300-1,900 l) and placed into 1,000-30,000 l fiber glass spawning tanks. Fish were handled carefully to avoid surface abrasions which could result in infections. External parasites were removed with a 25-50 ppm bath of malachite green and Formalin.³ After this treatment the fish were placed in spawning tanks. Details of the seawater holding facilities are described by Arnold et al. (1976).

Photoperiod and temperature data were gathered from U.S. Coast Guard and U.S. Weather Service records for Port Aransas, Tex. By comparing larval collections or adult spawning records of

¹Contribution No. 631 of The University of Texas Marine Science Institute.

²The University of Texas Marine Science Institute, Port Aransas Marine Laboratory, Port Aransas, TX 78373.

³Reference to trade names does not imply endorsement by the National Marine Fisheries Service, NOAA.

redfish (Simons and Breuer 1962), southern flounder (Stokes 1975), spotted trout (Miles 1950), and red snapper (Mosely 1966), the photoperiods and temperatures for the natural spawning seasons were determined. The laboratory photoperiod and temperature regimes for induced spawning of these four species were based on these meteorological and hydrological records.

Adults of the three species collected began feeding from 1 to 14 d after introduction to the spawning tank. Frozen penaeid shrimp and mullet were fed ad libitum at 1.6% of the adult body weight during 1973-76; but, after 1976 only shrimp was fed and mullet was discontinued because a suspected bacteria carried by mullet caused mortality in redfish. Immature red snapper fed almost immediately after collection on frozen penaeid shrimp and sciaenid fish at 5% body weight. Red snapper diets were reduced proportionately over the 12-mo period to ad libitum feedings of about 1.6% of the adult body weight.

Loadings of adult fish per volume filter box have not exceeded 60 kg (0.137 g/cm³), except 6 adult redfish (70 kg) were maintained successfully by the addition of a second filter box and air lift. The mean loadings of filters and number of fish for red drum was 0.080 g/cm³ (6 fish), spotted seatrout 0.044 g/cm³ (12 fish), flounder 0.025 g/cm³ (12 fish), and red snapper 0.037 g/cm³ (12 fish). The ratio of males to females was 1:1 in most of our experiments. Flow per unit weight ranged from 1.5 to 2.3 l/kg fish per min which was much lower than reported for freshwater trout in closed systems (Fyock 1977).

Eggs of the four species were buoyant and were collected from the filter box surface (Arnold et al. 1976). Mean egg size and larval hatching times were similar for the three pelagic species, but the flounder had a much longer larval developmental period with much lower hatch success (Table 1). Larval total length at hatch was similar for all species.

Until 1974, water quality was maintained by weekly flushings with fresh seawater and weekly vacuuming of the tanks. In 1974, a program of daily sampling for ammonia, nitrite, and nitrate was initiated to match feeding rates with these water quality parameters. When 0.5 mg/l NH₃, 0.9 mg/l NO₂, or 30.0 mg/l NO₃ was reached, ad libitum feeding rates were reduced for a few days or fresh seawater was added. But, if 3% body weight feeding rates were not exceeded and tanks vacuumed weekly, these concentrations were not exceeded. Uneaten food was immediately removed from spawning tanks.

Laboratory temperatures and photoperiods were set to approximate those at collection near Port Aransas. Depending upon the acclimation process and weight regaining process, a period of 15-40 d was spent in this first laboratory regime before fish were changed into a laboratory season. Once fish had been moved to a laboratory season, independence from the natural environment was completed.

RESULTS

The initial spawning experiments on these four species were patterned on the natural water temperature and photoperiods during each of the four seasons; however it can be noted that spawning started at < 365 d in the red drum (317 d) and spotted seatrout (253 d). Southern flounder were in the primary stages of gonad maturation at capture and laboratory cycling was set to lead these 12 fish into their natural spawning season over a 131-d period. Juvenile red snapper were maintained for 2 yr from capture to maturity. Nine spawns were recorded over a 45-d period.

Red snapper are regarded as an offshore Gulf species that frequents reef structures, unlike the other three euryhaline species. Two hundred and thirty-one days after being placed in the brood tank the first of seven spawns over a 40-d period occurred (Arnold et al. 1978). Spawning was observed only one time. Egg release occurred (during this observation) at the tank surface in the evening and involved one female and three males. No bodily contact or butting by males was observed. A total of 2.8×10^4 eggs were produced with an average of $1.5-2.0 \times 10^3$ eggs/kg in these first year spawning fish. It is believed that this *Lutjanus* species may be a multiple or a continuous spawner but a malfunction in the environmental control system of 4 d interrupted the laboratory spawning regime.

Red drum were maintained for 268 d when the first spawning behavior was noted and 49 d later, the first spawning occurred (Arnold et al. 1977). Sexual dimorphism in this species is not distinct, but initial spawning behavior and drumming and butting by males permitted sexual identification of the three males. At spawning, males took on a dorsal blue-black and ventral silvery-white coloration. Females were butted and pushed to the water surface where eggs were released. Spawning was a social behavior with males and females participating en toto; only at the egg release near laboratory dusk did spawning become a sole female

Table 1.—Spawning experiment data and relationships for spotted seatrout, red drum, southern flounder, and red snapper induced to spawn by temperature and photoperiod cycling.

Item	Spotted seatrout	Red drum	Southern flounder	Red snapper
Date test started	8/6/73	10/1/74	8/13/76	9/16/77
Date of first spawn	4/18/74	8/14/75	12/21/76	5/7/78
Date of final spawn	7/30/76	11/3/75	1/3/77	6/12/78
Number of spawns	82	52	13	7
Number of eggs/spawn	5.8×10^4	1.5×10^6	5.0×10^3	2.5×10^3
Photoperiod (h L-h D)	15-9	12-12	9-15	15-9
Temperature range (°C)	23-26	22-26	16.5-17.5	23-25
Salinity range (‰)	25-30	26-30	25-30	31-34
Mean egg size (mm)	0.77 mm	0.95	0.93	0.80
Number of oil droplets	1	1	1	1
Percent fertilization rate	99	> 99	30-50	> 90.0
Hours to hatch	15 h @ 27°C 21 h @ 23°C	19-20 h @ 24°C	61-71 h @ 24°C	20 h @ 24°C
Percent hatch rate	95-99	94-99	6-35	> 95
Total length larvae @ hatch (mm)	1.3-1.6	1.7-1.9	1.3-1.5	1.7-1.9

and multiple male activity. No aggressive behavior by either sex was noted. A total of 52 spawns over 76 d produced 60×10^6 eggs (Table 1). From spawn 41 to the end, egg number decreased from about 1.5×10^6 to 5.0×10^4 eggs per spawn delineating the end of the spawning season. The average per female was 1.8×10^6 eggs/kg. Whether spawning ceased as a response to a lack of eggs in the ovaries, or some endogenous rhythm, was not ascertained. Red drum are classified as multiple spawners within their spawning season.

Southern flounder were collected at the beginning of the winter spawning run to the Gulf. Males were distinguished easily from large females by their smaller size and their movement to Gulf waters before females. Six females placed in the spawning tank began to hydrate 21-28 d prior to spawning. At this time, males began to follow the females around the perimeter of the tanks. Several days before spawning, males positioned their heads near the females vent. Spawning at midday occurred at the surface between one pair of fish. No aggression or competition for a female, or between any fish, was noted. A total of 13 spawns by the three largest females produced a total of 1.2×10^5 eggs. The average varied from 1.0 to 1.5×10^3 eggs/kg. At the end of spawning, all females were hydrated indicating the presence of eggs in the ovaries. No explanation for this cessation of spawning was found. Southern flounder are multiple spawners within a set spawning season, but to a lesser degree than red drum.

Spotted seatrout placed in brood tanks spawned 30 d after the laboratory spawning period was initiated and spawned 82 times over the next 380 d. Sexual dimorphism in this species is not pronounced but generally females tend to be larger. Sexual identification of the six males was made at spawning time by the presence of a dark black stripe 1-3 cm wide which was superimposed upon the lateral line system. At laboratory spawning time (dusk) as the social courtship intensified, the coloration of the male stripe also intensified. Spawning occurred at the surface with a female and several males. Eighty-two spawns over a 380-d period at 23°-26°C produced approximately 7.1×10^7 eggs. Our experiment ceased because laboratory conditions were changed. Whether spawning would have continued is unknown.

These initial results suggest that natural spawning of marine fish is indeed possible and that prolonged spawning of some species may provide a continuous supply of eggs and larvae for aquaculture.

LITERATURE CITED

- ARNOLD, C. R., W. H. BAILEY, T. D. WILLIAMS, A. JOHNSON, and J. L. LASSWELL.
1977. Laboratory spawning and larval rearing of red drum and southern flounder. Proc. Annu. Conf. Southeast. Assoc. Fish Wildl. Agency 31: 437-440.
- ARNOLD, C. R., J. L. LASSWELL, W. H. BAILEY, T. D. WILLIAMS, and W. A. FABLE, Jr.
1976. Methods and techniques for spawning and rearing spotted seatrout in the laboratory. Proc. Annu. Conf. Southeast. Assoc. Fish Wildl. Agency 30: 167-178.
- ARNOLD, C. R., J. M. WAKEMAN, T. D. WILLIAMS, and G. D. TREECE.
1978. Spawning of red snapper (*Lutjanus campechanus*) in captivity. Aquaculture 15:301-302.
- BARDACH, J. E., J. H. RYTHER, and W. O. McLARNEY.
1972. Culture of miscellaneous brackish water and inshore marine fishes. Culture of marine flatfishes. In Aquaculture, the farming and husbandry of freshwater and marine organisms, p. 541-556; 575-586. Wiley-Interscience, N.Y.
- FYOCK, O. L.
1977. Nitrification requirements of water re-use systems for rainbow trout. Colorado Div. Wildl., Spec. Rep. 41, 31 p.
- GARZA, G., W. H. BAILEY, and J. L. LASSWELL.
1978. Rearing of black drum in fresh water. Prog. Fish-Cult. 40:170.
- HOAR, W. S.
1959. Endocrine factors in the ecological adaptation of fishes. In A. Gorbman (editor), Comparative endocrinology, p. 1-23. Wiley, N.Y.
- HOFF, F., Jr., J. A. MOUNTAIN, T. A. FRANKS, T. R. PULVER, and R. B. FUTCH.
1977. Controlled conditioning and spawning of the Florida pompano, *Trachinotus carolinus*, and southern sea bass, *Centropristis melano*. [Abstr.] Fla. Mar. Res. Publ., Fla. Board Conserv., Tallahassee, Fla.
- JOHNSON, A. G., T. D. WILLIAMS, and C. R. ARNOLD.
1977. Chlorine-induced mortality of eggs and larva of spotted seatrout (*Cynoscion nebulosus*). Trans. Am. Fish. Soc. 106:466-469.
- KUO, C. M., C. E. NASH, and Z. H. SHEHADEH.
1974. The effects of temperature and photoperiod on ovarian development in captive grey mullet (*Mugil cephalus* L.). Aquaculture 3:25-43.
- LASKER, R., and L. L. VLYMEN.
1969. Experimental sea-water aquarium. Bureau of Commercial Fisheries Fishery-Oceanography Center, La Jolla, California. U.S. Fish Wildl. Serv., Circ. 334, 14 p.
- MILES, D. W.
1950. The life histories of the spotted seatrout, *Cynoscion nebulosus*, and the redfish, *Sciaenops ocellatus*. Tex. Game Fish Mar. Lab., Annu. Rep. 1949-50, 38 p.
- MOSELY, F. N.
1966. Biology of the red snapper, *Lutjanus aya* Bloch, of the northwestern Gulf of Mexico. M.S. Thesis, Univ. Texas, Austin, 53 p.
- PICKFORD, G. E., and J. W. ATZ.
1957. The physiology of the pituitary gland of fishes. New York Zool. Soc., N.Y., 613 p.
- SIMONS, E. G., and J. P. BREUER.
1962. A study of redfish, *Sciaenops ocellatus* Linnaeus. Publ. Inst. Mar. Sci., Univ. Tex. 8(1962):184-211.
- SPOTTE, S. H.
1970. Fish and invertebrate culture. Water management in closed systems. Wiley-Interscience, N.Y., 145 p.
- STEVENS, R.
1966. Hormone-induced spawning of striped bass for reservoir stocking. Prog. Fish-Cult. 28:19-28.
- STOKES, G. M.
1975. Life history studies of southern flounder (*Paralichthys lethostigma*) and gulf flounder (*P. albigutta*) in the Aransas Bay area of Texas. Tex. Comm. Fish. Res. Dev. Proj. Final Rep. 2-221-R. Tex. Parks Wildl. Dep., Austin, 60 p.

Striped Bass Culture in the United States

BOB STEVENS¹

ABSTRACT

Striped bass, *Morone saxatilis*, is native to the Atlantic and gulf coasts of the United States but its popularity as a sport and a commercial fish has led to its establishment on the Pacific Coast and in inland reservoirs in 17 states.

Over 15 million fingerling striped bass are annually produced by state and federal hatcheries for stocking in reservoirs and estuaries. Advances in striped bass culture within the past 15 yr have made the program possible.

INTRODUCTION

The striped bass is of major importance as a food fish and a game fish in the United States. Its original range was on the Atlantic coast from the St. Lawrence River to the St. John's River in northern Florida and in the Gulf of Mexico from western Florida to Louisiana (Raney et al. 1952). In 1879 and 1881, yearling striped bass were seined from the Navesink River, N.J., and liberated in San Francisco Bay from whence they populated the west coast of the United States.

The striped bass thrives in fresh, brackish, and saltwaters, in the juvenile and adult stages, but it must spawn in freshwater streams. While some populations such as those in the Chesapeake Bay and Hudson River make inshore, coast-wide migrations beginning at age 2, the species is by no means as strongly anadromous as Atlantic and Pacific salmon or the shad and herring of the Atlantic coast.

In 1941, the Santee Cooper Reservoir was created by the construction of a hydroelectric dam on the Cooper River, S.C. The dam served to impound 160,000 acres of water and to inundate portions of the Cooper and Santee Rivers which had historically supported large populations of striped bass. By 1949, a large population of small striped bass was present and by 1952, a sport fishery for the species existed with the reservoir. It was determined by Scruggs and Fuller (1955) that the population was landlocked, i.e., that the Wateree and Congaree Rivers above the reservoir were providing the spawning grounds for the species and that conditions within the reservoir were suitable for the growth and survival of the species. During the next 5 yr, the population increased dramatically and produced one of the largest populations of striped bass per volume of water ever to be observed (Stevens 1958). The species thrives to this day within the reservoir.

ARTIFICIAL PROPAGATION

Spawning

The first striped bass hatchery was established in 1906 on the Roanoke River at Weldon, N.C., by the Bureau of Biological Services, which was the predecessor agency of the U.S. Fish and

Wildlife Service. A prototype hatchery was operated by S. G. Worth beginning about 1881. The hatchery is located on the spawning grounds of the Albemarle Sound population of striped bass and is unique in that fish of both sexes can be taken in large dip nets in the act of spawning. The ripe eggs are fertilized and placed in hatching jars, the larvae hatch around 36 h later, depending on the water temperature, into aquaria from which they are stocked into rivers and streams. In recent years, the hatchery has been operated by the North Carolina Wildlife Resource Department.

In 1961, the Moncks Corner Striped Bass Hatchery was built on the tailrace below the Santee Cooper Reservoir by the South Carolina Wildlife Department. The hatchery was built for the purpose of supplying the demand for larvae which had been created by the successful establishment of striped bass within the reservoir and the excellent sport fishing which it produced. In other words, fish biologists and sport fishermen were interested in establishing such populations in other reservoirs throughout the Southern United States.

The Moncks Corner Hatchery was patterned after the Weldon hatchery but, despite a major fishing effort, no ripe females were captured in the tailrace in 1961 and no eggs were taken.

In 1962, hormones were injected into 162 female striped bass in order to induce ovulation. Due to inadequate facilities and ignorance of the phenomenon of overripeness, only 2.64 million fry were produced (Stevens and Fuller 1965).

In 1963, 429 female striped bass were injected with hormones and 13.8 million fry were produced. It was concluded that new holding facilities for the adult fish would have to be constructed to observe and frequently capture female striped bass in order to better define the role of overripe eggs as a source of egg mortality (Stevens et al. 1965).

In 1964 new holding facilities were available, the negative role of overripe eggs was defined, and 100 million larvae were produced from 337 females which has spawned 372 million eggs (Stevens 1965, 1967a).

The percent hatch of eggs produced in 1962, 1963, and 1964 was 7.3, 17.0, and 31.0, respectively. Although it was suspected as early as 1962 that ovulated ovarian eggs rapidly deteriorate in quality due to hypoxia, the phenomenon was demonstrated conclusively only in 1964. Also a technique of intra-ovarian sampling of ova from the ovary of living fish with a small glass catheter was perfected. This enabled the prevention of the overripe state because eggs from the female could be periodically examined microscopically in order to predict the time of ovulation.

¹Chief of Fishery Research, U.S. Fish and Wildlife Service, Department of the Interior, Washington, DC 20242.

The protocol for successful hormone-induced ovulation to be described below launched striped bass culture in the United States (Stevens 1966).

Protocol for Hormone Induced Ovulation of Striped Bass

- 1) Adult male and female striped bass are captured during the spring spawning season on or near their natural spawning area and immediately injected with at least 127 I.U. of chorionic gonadotropin per pound (0.45 kg).
- 2) Twenty-two hours after injection an intra-ovarian sample of eggs is taken and examined microscopically in order to predict the time when the eggs will reach Stage VI.
- 3) Females are segregated according to estimated time of ovulation.
- 4) After reaching Stage VI, the stomach of the female is palpated every 30 to 60 min in order to determine whether ovulation has taken place. Eggs remaining in the ovary more than 30-60 min become overripe and will not hatch.
- 5) Ripe females are manually stripped of their eggs. Sperm from one or more males are stripped upon the eggs and the sex products are mixed by hand.
- 6) Water is then added and the fertilized eggs are placed in hatchery jars at the rate of 100,000/jar.
- 7) The eggs hatch in about 36 h, depending upon the water temperature, and are shipped to rearing stations between day 1 and day 5.

At the present time, approximately 12 striped bass spawning hatcheries exist in the United States. Several are located far inland and they depend upon spawning stock which were originally introduced into inland reservoirs as fingerlings.

In 1974, Bishop (1975), of the Tennessee Wildlife Resource Agency, developed a new technique for spawning and hatching striped bass which has been adopted by several of the above-mentioned hatcheries. The new technique involves the use of circular tanks into which hormone-injected, wild, gravid females and males are placed. In most cases the fish spawn, whereupon, they are removed from the tank. The fertilized eggs hatch in the tank, and 4 or 5 d later the fry become concentrated around the edge of the tank and are dipped out for distribution to rearing facilities. This technique has several advantages as follows. 1) The labor and equipment involved in handling, ova-sampling, spawning, and hatching are reduced or eliminated. 2) The hatchery manager does not have to be experienced in predicting the time of ovulation and egg overripeness. In fact, overripeness is avoided. 3) The hatch is equal or superior to the Stevens method. 4) The adult fish can be released in much better condition, perhaps to spawn again. This technique is highly recommended.

Care and Feeding of Larval Striped Bass

Striped bass larvae begin feeding 5 d after hatching and on that day they must be offered brine shrimp or zooplankton or be released in earthen ponds where they find naturally produced zooplankton and insect life. (Experiments concerning the release of fry into the wild demonstrated a low survival rate and it was concluded in the early 1960's that the rearing of larvae to fingerlings before release into the wild was the most efficient way to produce striped bass populations in reservoirs.)

The larvae are usually transported to the pond site in sealed, plastic bags containing 15 l of water and 0.014 m³ of gaseous oxygen. The bag is placed in a styrofoam container in order to main-

tain water temperature at 21°C or less because fry younger than 9 d old are intolerant of higher water temperature (Stevens 1967b).

Between 25,000 and 100,000 larvae can be transported to the rearing site in this manner in time periods up to about 12 h. Longer trips require less density.

Rearing

Earthen ponds, which have previously been dewatered for 2 to 16 wk, are filled several days prior to stocking the fry. Organic fertilizer is placed in the pond prior to and during the 40-50 d growing phase. Hay at 900-1,100 kg/ha or cotton seed or soybean meal at 170-225 kg/ha has succeeded in producing 1.6 to 2.3 kg of fingerlings per hectare per day over a 40-d growing period (Stevens 1975).

In 1975, the Hudson River larval striped bass were reared in earthen ponds at the Edenton National Fish Hatchery in North Carolina (Baker 1976). This rearing effort employed the use of dried fish food which was fed daily during the latter part of the rearing period. Average production in 18 ponds was 3.1 kg/ha per d in a 47-d growing season.

In 1974, the federal hatchery system averaged about 74,000 fingerlings per surface hectare weighing 39 kg in a 39-d growing season (Brashler 1975). Wide variation in production was the rule between hatcheries and between individual ponds. For example, at the Edenton National Fish Hatchery in 1974, an average production of 160,000 fish weighing 100 kg was achieved per hectare in a total of 2.4 ha (Ware 1975). The above mentioned rearing experiment by Baker at Edenton in 1975 produced an average 94,000 fingerlings per hectare in 5.7 ha.

Fingerlings are removed from the rearing ponds after 40-50 d because the natural food becomes depleted. If large fingerlings are desired, the same ponds can be refilled and stocked at the rate of 62,000, 5 cm fingerlings per ha. Artificial diets provide the food. Baker (1976), reared 273,000 12 cm fingerlings in an average of 76 d after restocking in 16 ponds at Edenton. Survival was 82% of the Phase I fingerlings stocked.

The current annual production of striped bass fingerlings in the United States is over 15 million. These fingerlings are produced in about 200 ha of rearing ponds located at state and federal fish hatcheries throughout the Southern United States.

The fingerlings are stocked in reservoirs and estuaries in order to establish, reestablish, or enhance striped bass populations. Most reservoirs do not have suitable spawning grounds and so the population must be maintained by annual or periodic stocking.

Intensive Rearing

Larvae.—Many attempts to rear larval striped bass intensively have been made in recent years with rather limited success. Very little survival has been possible when attempting to feed prepared diets to post-larvae. The feeding of brine shrimp and zooplankton followed by prepared diet has met with greater success (McIlwain 1976²). At this writing, however, pond culture is the only feasible way of rearing striped bass in large quantities.

Fingerlings.—Contrary to the results with larvae, fingerlings can easily be trained to take dried diets and have been reared in

²McIlwain, T. D. 1976. Annual progress report on striped bass rearing and stocking program — Mississippi. Unpubl. rep., 33 p. Gulf Coast Research Laboratory, Ocean Springs, Miss.

large quantities in raceways. In Florida, a now defunct commercial enterprise (Marine Protein Corp.) reared large numbers of fingerlings and sub-adults in raceways and silos. The author was the manager in charge of a pond rearing facility in North Florida (Palatka) where striped bass larvae were reared to fingerlings and a raceway-silo facility in south Florida (Homestead) where the fingerlings were reared and sold as advanced fingerlings or reared as food fish. While most of the information engendered is proprietary, the following statements can be made. 1) Over 300,000 fingerlings were reared in 208 l drums or 1,100-1,900 l horizontal raceways. 2) Sixty thousand fingerlings were sold for stocking in ponds and lakes in the United States, and, on 2 July 1974, 3,000 fingerlings were successfully shipped by air to the University of Tokyo. 3) Two hundred forty-four thousand fingerlings were stocked into six silos at lengths varying between 5.3 and 18.5 cm. The silos were of different heights and contained between 70,400 and 136,600 l of water. 4) Four thousand five hundred kilograms of advanced fingerlings (25-28 cm) and over 9,000 kg of food fish (35-46 cm) were produced in six silos in 1973 and 1974. 5) Major problems included pesticide poisoning (heptachlor epoxide) from surrounding truck farms, bacterial diseases (*Flexibacter columnaris*, *Aeromonas* sp.), cannibalism, and the "oil crunch" which increased pumping costs beyond feasibility.

Hybridization

Between 31 March and 18 April 1965, the author, while serving as manager of the Moncks Corner Striped Bass Hatchery, fertilized three different groups of striped bass eggs with sperm from white bass, *Morone chrysops*. The cross was successful and the hybrid has proven itself to be a valuable addition to the overall striped bass program in the United States because it almost invariably survives better than striped bass in the larval, fingerling, and sub-adult stages. In addition, it grows as well or better than striped bass for the first 5 yr. It does not successfully reproduce itself in the wild and does not live as long as striped bass, and therefore, produces few fish over 6.8 kg. Because of its high survivability, a hybrid fishery can be produced and maintained at much less cost and effort than is possible with striped bass (Ware 1975).

Two other species, *M. americana* and *M. interupta*, have also been crossed with striped bass but none have proven to be as vigorous and as successful as the original cross, striped bass female vs. white bass male (Bayless 1972). Bishop (1975) pointed out that the tank culture method is not effective for hybrid fry production because female striped bass will not release their eggs in the presence of white bass males.

CONCLUSIONS

The striped bass has found favor with fisheries managers since the end of the last century. The early work of S. G. Worth at Weldon, N.C., around the turn of the century has been amplified by modern workers over the past 15 yr and, as a result, inland fisheries occur in 30 reservoirs in 17 different states (Massmann 1975). Enhancement efforts in estuaries in Florida, Alabama, Mississippi, Louisiana, California, Texas, and New York are being carried out with promising results. The Soviet Union has succeeded in establishing one or more wild populations from larvae shipped from the Moncks Corner Hatchery in 1965.

Much needs to be learned concerning the optimum number of fingerlings which should be introduced into a given body of water and there is no doubt that culture techniques can be made more efficient with additional research (Bonn et al. 1976). Commercial aquaculture of striped bass, which failed in the mid-1970's, may be tried again in the near future because of more favorable markets and better techniques. The inland reservoir striped bass program will continue to grow and to benefit the sport fishermen. The estuarine striped bass enhancement program will benefit both sport and commercial fishermen.

LITERATURE CITED

- BAKER, J. E.
1976. The rearing of Hudson River striped bass at the Edenton National Fish Hatchery, 1975. Final report prepared for Consolidated Edison Company of New York, Inc., 16 p.
- BAYLESS, J. D.
1972. Artificial propagation and hybridization of striped bass, *Morone saxatilis* (Walbaum). S.C. Wildl. Mar. Res. Dep., 135 p.
- BISHOP, R. D.
1975. The use of tanks for spawning striped bass (*Morone saxatilis*). Proc. 28th Annu. Conf. Southeast. Assoc. Game Fish Comm. 1974, p. 35-44.
- BONN, E. W., W. M. BAILEY, J. D. BAYLESS, K. E. ERICKSON, and R. E. STEVENS (editors).
1976. Guidelines for striped bass culture. Am. Fish. Soc., Bethesda, Md., 103 p.
- BRASCHLER, E. W.
1975. Development of pond culture techniques for striped bass *Morone saxatilis* (Walbaum). Proc. 28th Annu. Conf. Southeast. Assoc. Game Fish Comm. 1974, p. 44-48.
- MASSMANN, W. H.
1975. Twenty five years of federal-state cooperation for improving sport fishing: accomplishments under the federal aid in fish restoration program, 1950-1975. U.S. Dep. Inter., Fish Wildl. Serv., Wash., D.C., 37 p.
- RANEY, E. C., E. F. TRESSELT, E. H. HOLLIS, V. D. VLADYKOV, and D. H. WALLACE.
1952. The striped bass (*Roccus saxatilis*). Bull. Bingham Oceanogr. Collect. Yale Univ. 14, 177 p.
- SCRUGGS, G. D., Jr., and J. C. FULLER, Jr.
1955. Indication of a fresh water population of striped bass, "*Roccus saxatilis*" (Walbaum), in Santee-Cooper Reservoir. Proc. Southeast. Assoc. Game Fish Comm. 1954, p. 64-70.
- STEVENS, R. E.
1958. The striped bass of the Santee-Cooper Reservoir. Proc. 11th Annu. Conf. Southeast. Assoc. Game Fish Comm. 1957, p. 253-264.
1965. A report on the operation of the Moncks Corner Striped Bass Hatchery. S.C. Wildl. Resour. Dep., 25 p.
1966. Hormone-induced spawning of striped bass for reservoir stocking. Prog. Fish-Cult. 28:19-28.
1967a. A final report on the use of hormones to ovulate striped bass, *Roccus saxatilis* (Walbaum). Proc. 18th Annu. Conf. Southeast. Assoc. Game Fish Comm. 1964, p. 525-538.
1967b. Striped bass rearing. North Carolina Cooperative Sport Fishing Unit, North Carolina State University, Raleigh, 14 p.
1975. Current and future considerations concerning striped bass culture and management. Proc. 28th Annu. Conf. Southeast. Assoc. Game Fish Comm. 1974, p. 69-73.
- STEVENS, R. E., and J. C. FULLER, Jr.
1965. A preliminary report on the use of hormones to ovulate striped bass, *Roccus saxatilis* (Walbaum). Proc. 16th Annu. Conf. Southeast. Assoc. Game Fish Comm. 1962, p. 222-235.
- STEVENS, R. E., O. D. MAY, Jr., and H. J. LOGAN.
1965. An interim report on the use of hormones to ovulate striped bass, *Roccus saxatilis* (Walbaum). S.C. Wildl. Resour. Dep., Mimeogr. Rep., 17 p.
- WARE, F. J.
1975. Progress with *Morone* hybrids in fresh water. Proc. 28th Annu. Conf. Southeast. Assoc. Game Fish Comm. 1974, p. 48-54.