

June 1997

SGEB-40

# Crab Shedding-System Designs

*Don Jackson and Don Sweat*

## **The Only Way?**

There are as many ways to build and arrange crab shedding setups as there are people who make them. The following drawings are suggestions based on the experiences of successful shedders. You may find changes that suit your operation better.

## **The Simpler - The Better!**

Tank floors can be 3/4-inch or 1-inch CD plywood. The sides can be made from 12-inch plywood, 2-by-10-inch boards, or 2-by-12-inch boards. They can be caulked at the seams and sealed with either fiberglass resin or a product such as Gluvit™. Tanks can be set on wood frames or concrete blocks. Fiberglass tanks work well, too.

All plumbing should be PVC. No metal should come in contact with the water, partly because of saltwater effects on the metal, but more for the health of the crabs. Size of PVC is important, too. The main feeder line from the pump to the individual spreaders should be 2-inch PVC. This creates less "head" than smaller piping, allowing for a large savings in electricity. Fewer bends in the plumbing are better; every elbow and tee increases friction, creating more head, and costing more money for pumping.

The drawings show two mechanical filters. You only need one. The reason we've shown two is to offer an option of placing the mechanical filter at the end of the drain line, or to mount it as an integral part of the biological filter. Either way works, it's a matter of convenience for cleaning it out regularly. You may not need one with a headwall if it is mounted above the biological filter — it can drain out the bottom. In that case, a plastic "milk" box might work as well.

The biological filter is the key factor in a closed system. Any building material will do, but concrete is probably the simplest, and may be cheapest in the long run. The size shown (about 5-by-10-feet) should service any expansion up to 20 tanks, depending on how many crabs are put in each tank.

---

Don Jackson is the Florida Sea Grant Blue Crab Project Coordinator and Don Sweat is the Florida Sea Grant Marine Agent for Levy, Citrus, Hernando, Pasco and Pinellas counties.



# Crab Shedding Tanks and Filters Closed System

3 tank setup - modular view

Mechanical (1) and Biological (2) filters can be arranged in several other configurations.

Drain system should have shortest runs possible to preserve "fall" for gravity drains - from first tank in line to Biological filter. This may necessitate burying this filter.

Tank spreaders illustrate 3 different ways of distributing water within the tank. All work well.

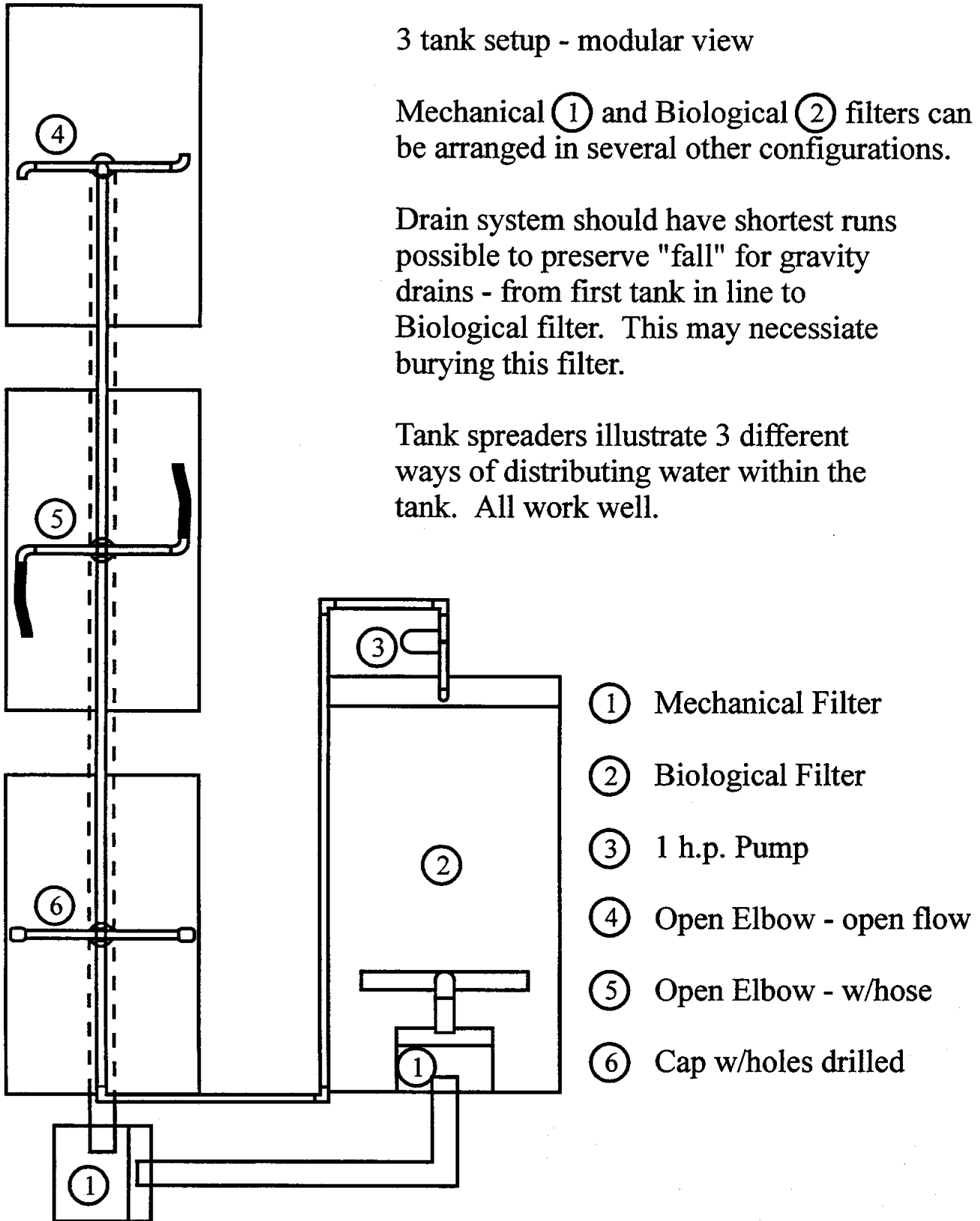

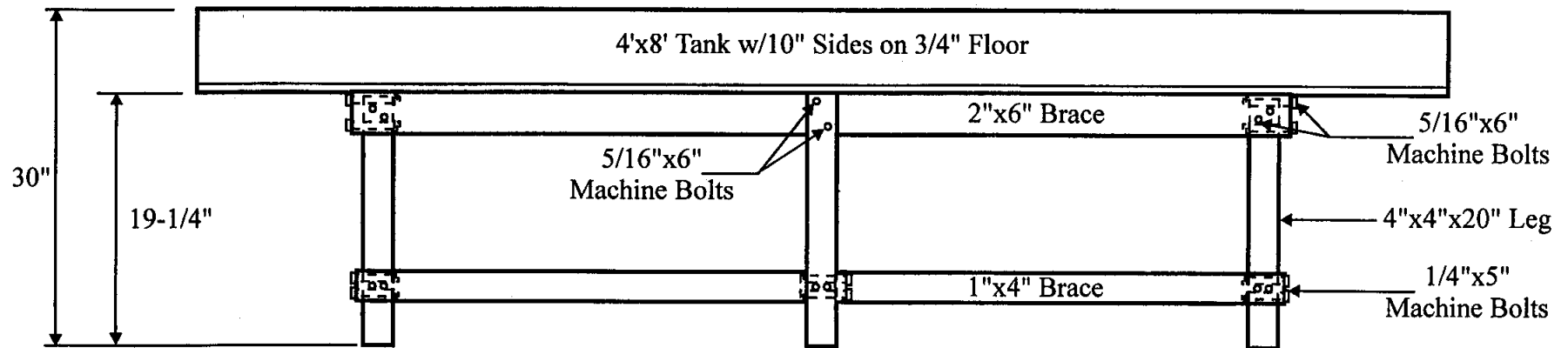
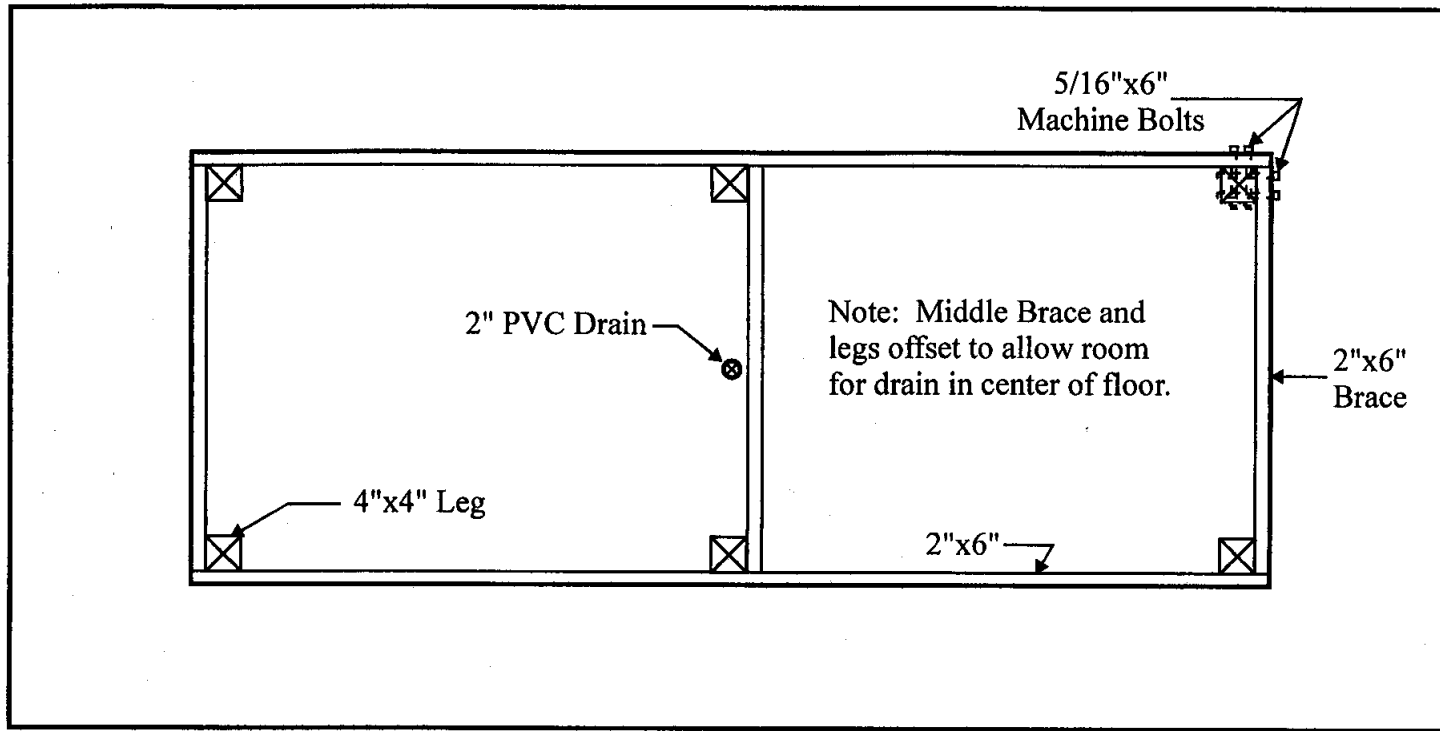

## Mechanical Filter

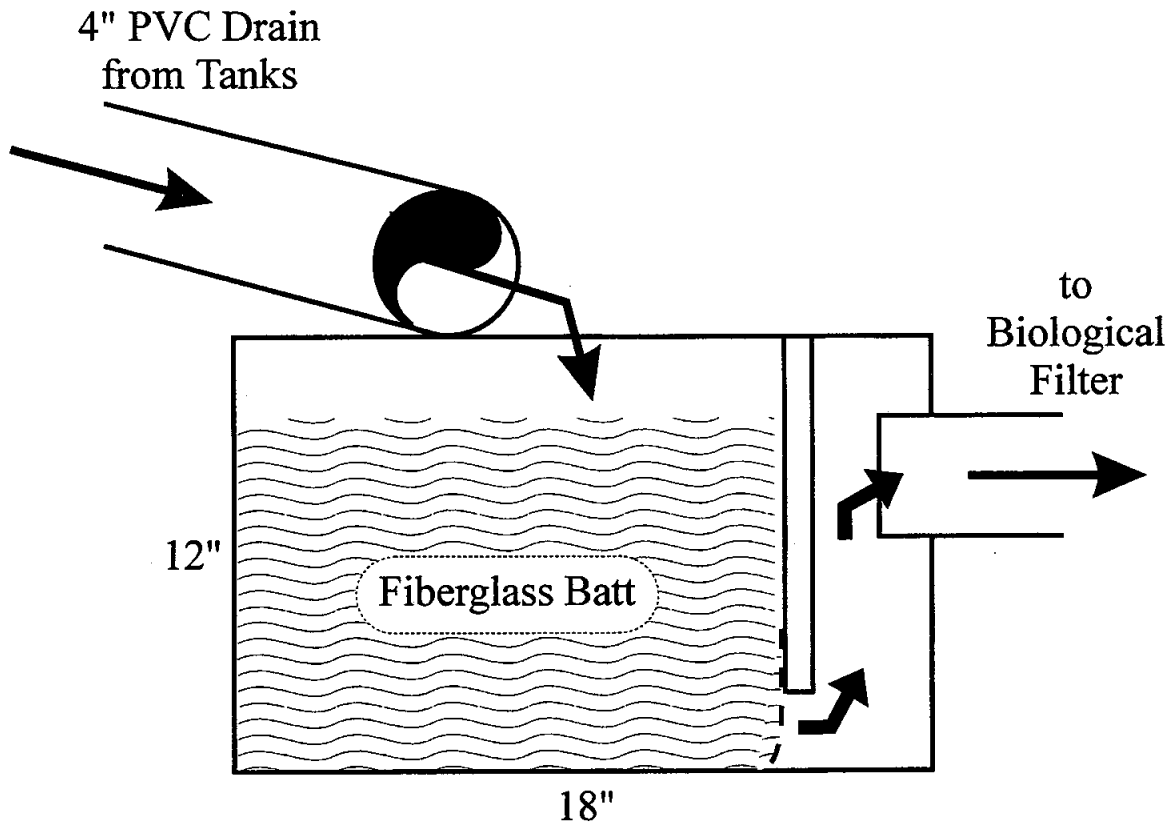

### NOTES:

1. Mechanical filter can drain from bottom if biological filter is below grade. Use of headwall-baffle system preserves head for gravity flow into biological filter if necessary.

2. Mechanical filter can be separate unit or placed inside tank of biological filter.

# Biological Filter

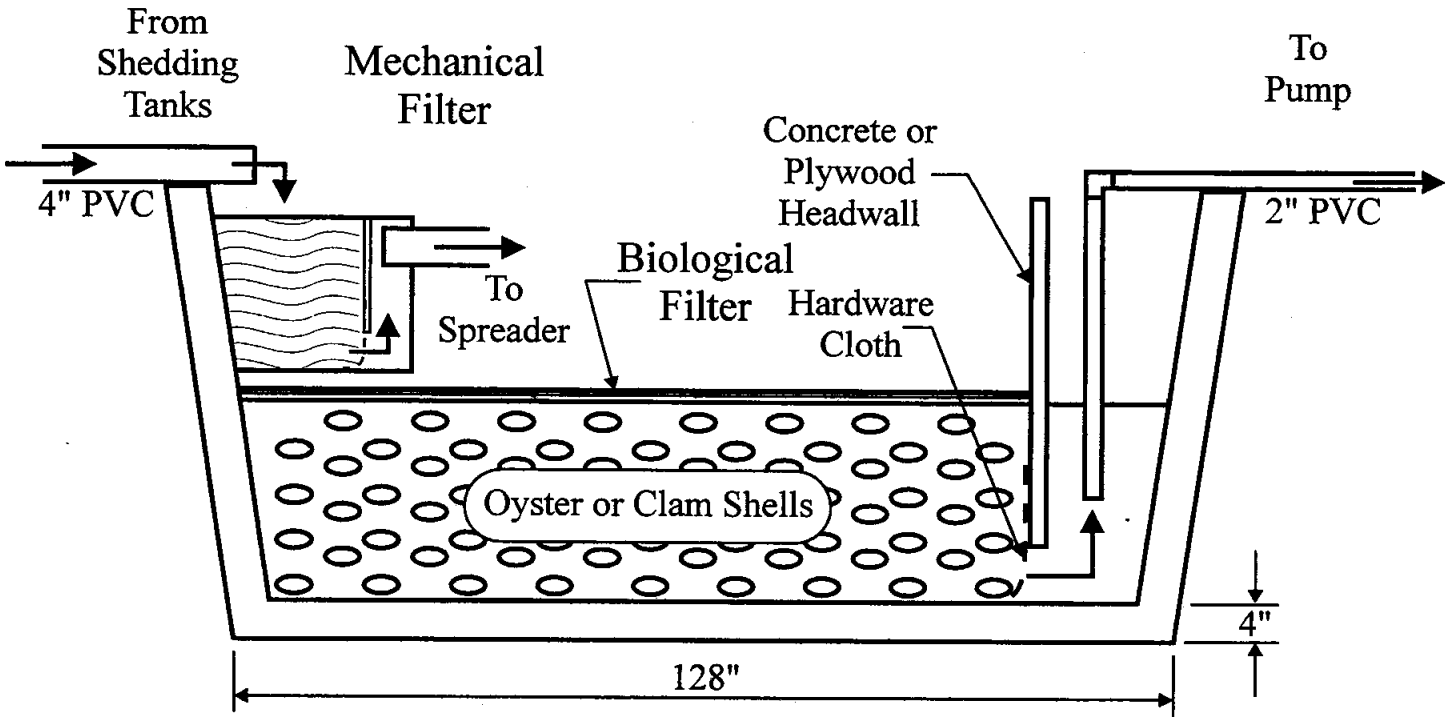

3500 PSI Concrete

Tank Reinforced with #3 Rebar @ 12" O.C.

Tank Only Weight = 5,452 lbs.

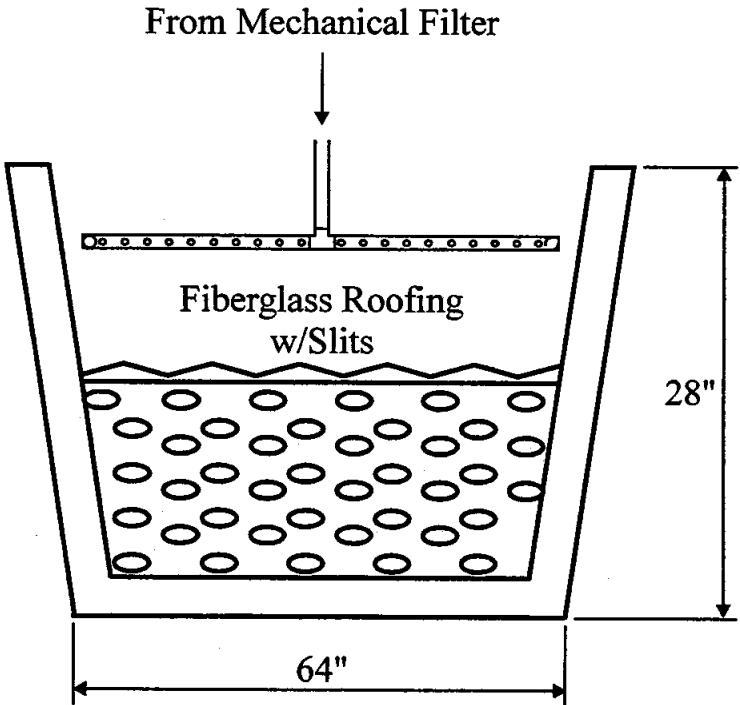

# Shedding Tank End View

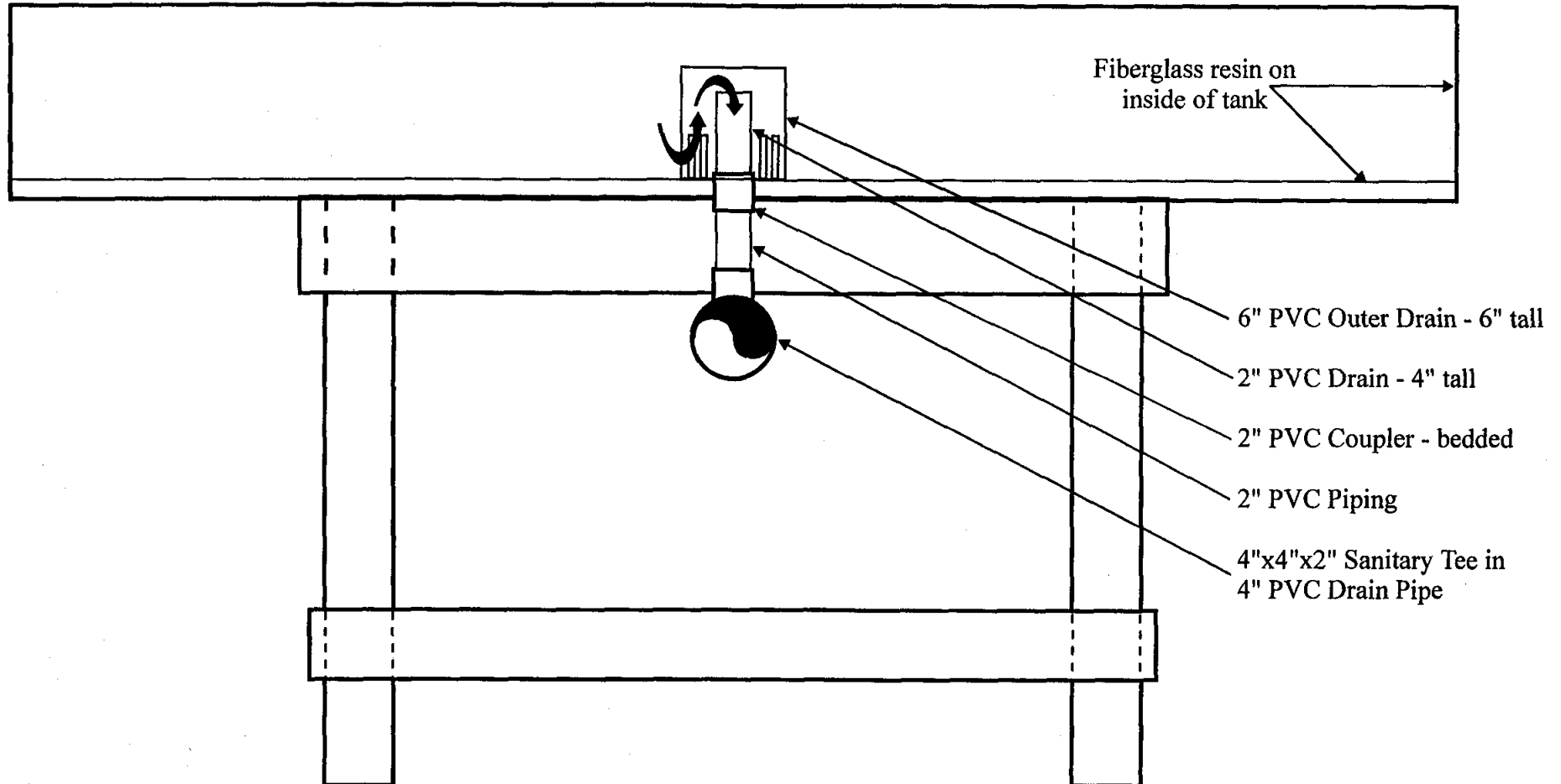

# Tank/Table Construction

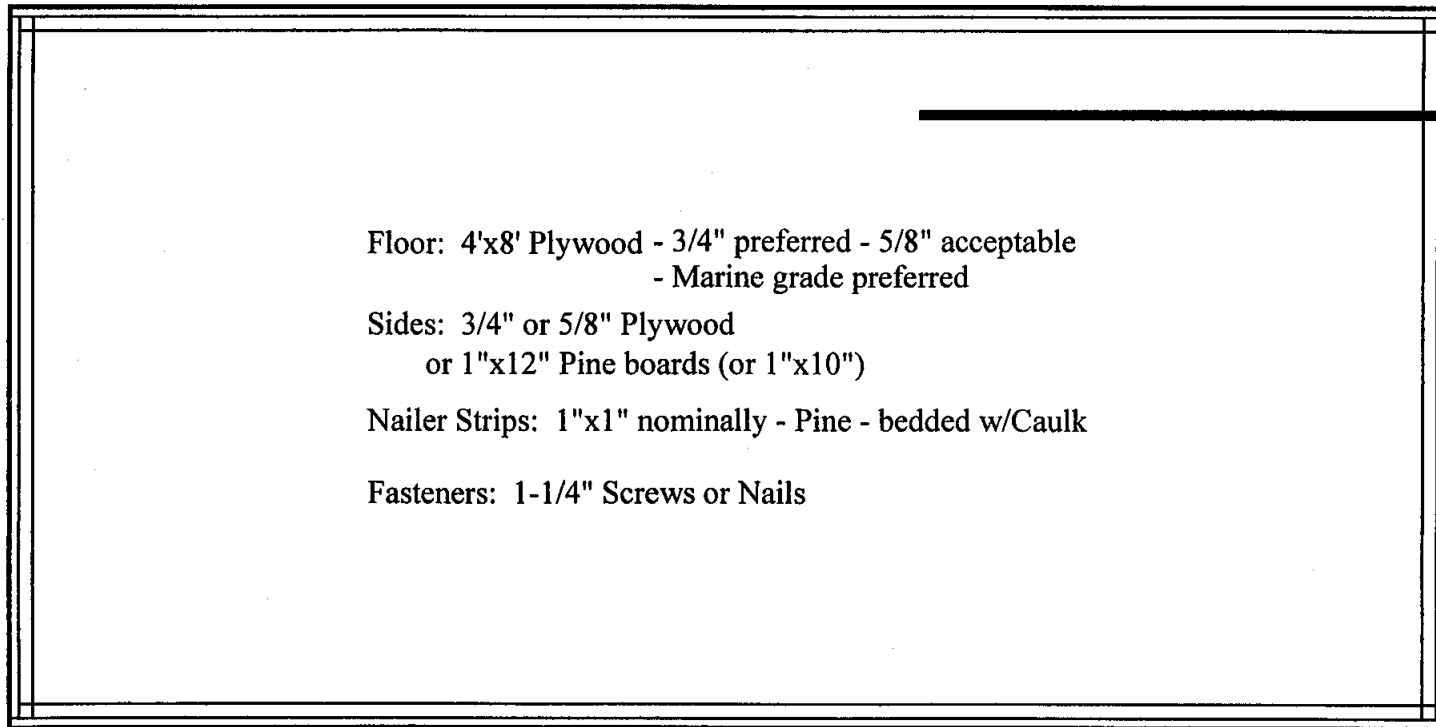
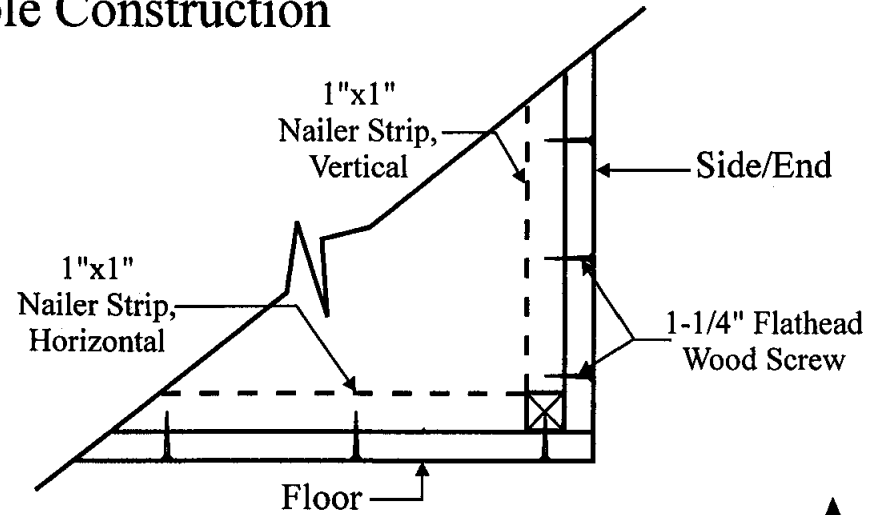

Floor: 4'x8' Plywood - 3/4" preferred - 5/8" acceptable  
- Marine grade preferred

Sides: 3/4" or 5/8" Plywood  
or 1"x12" Pine boards (or 1"x10")

Nailer Strips: 1"x1" nominally - Pine - bedded w/Caulk

Fasteners: 1-1/4" Screws or Nails

# Feed From Supply (Pump) Into Tank

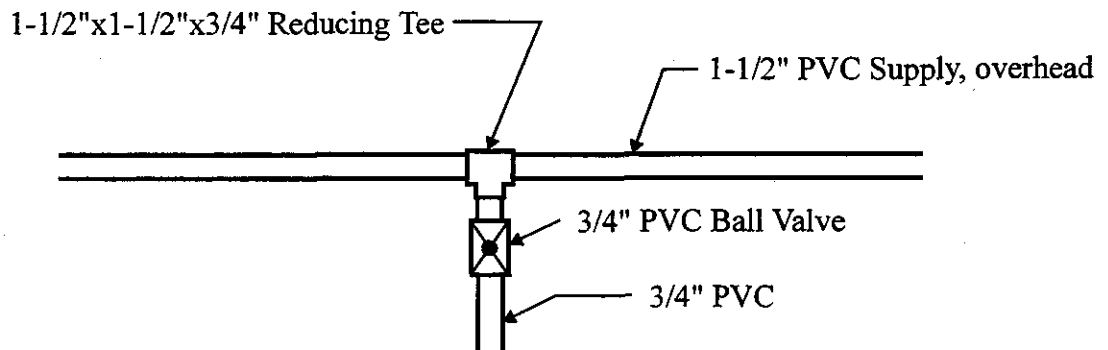

## Alternative A

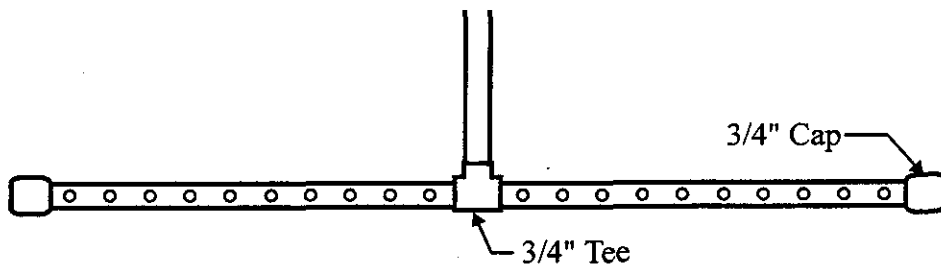

## Alternative B

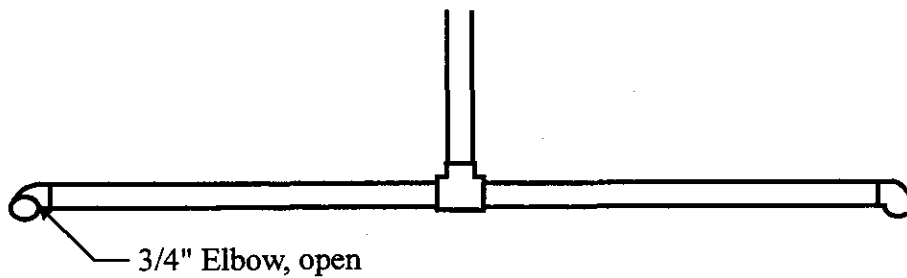

Note: Alternative C is similar to B with vinyl tubing attached.