

Università degli Studi di Bologna

DOTTORATO DI RICERCA IN FISICA
FIS/07 - Fisica applicata (a beni culturali, ambientali, biologia e medicina)

XIX CICLO
2003-2006

FACOLTÀ DI SCIENZE MATEMATICHE, FISICHE E NATURALI

Tesi di Dottorato

**ELECTRICAL ACTIVITY IN NEURONS
EXPOSED TO LOW LEVEL
ELECTROMAGNETIC FIELDS.
THEORY AND EXPERIMENTS**

Dott. Pietro Mesirca

Coordinatore:
Prof. Fabio Ortolani

Relatore:
Prof. Ferdinando Bersani

Dipartimento di Fisica
Bologna, marzo 2007

ACKNOWLEDGMENTS

At the end of this work, I would like to thank Prof F. Bersani and Prof G. Aicardi for giving me the chance to carry out this thesis and for the fundamental support for the planning and realization of it.

I would like to thank also Dr Baldazzi, Dr Castellini and Dr Zironi for their technical support.

In particular, I wish to thank Dr D. Platano for her stimulating suggestions and discussions concerning biology and, in particular, electrophysiology during all the period of this thesis.

Last but not least, this work would not have been possible without the help of Silvia and Lupo: I would like to thank them very much for assisting and, above all, supporting me during this (long) period.

TABLE OF CONTENTS

CHAPTER 1	pag 1
INTRODUCTION	pag 1
1.1 Aim of the research project	pag 6
CHAPTER 2	pag 8
MATERIAL AND METHODS	pag 8
2.1 ELF exposure system	pag 8
2.1.1 Temperature measurements	pag 16
2.2 RF exposure system	pag 17
2.2.1 The generation unit	pag 17
2.2.2 Exposure device	pag 19
2.2.3 Temperature measurements	pag 24
2.3 Extracellular field potential recording technique	pag 25
2.3.1 Slice preparation and electrophysiological measurements	pag 28
2.3.2 Basal synaptic transmission	pag 30
2.3.3 Long Term Potentiation	pag 31
2.4 Exposure conditions	pag 32
2.4.1 ELF experiments	pag 32
2.4.2 RF experiments	pag 34
2.5 Statistical analysis	pag 37
CHAPTER 3	pag 38
RESULTS	pag 38
3.1 ELF effects on synaptic transmission	pag 39
3.2 ELF effects on LTP maintenance	pag 46
3.3 RF effects on synaptic transmission (1 hour experiments)	pag 50
3.4 RF effects on synaptic transmission (5 minute	

experiments)	pag 55
3.4.1 GSM 2 W/kg and 4 W/kg	pag 58
3.4.2 CW 2 W/kg	pag 60
3.4.3 CW 4 W/kg	pag 61
3.5 RF effects on the induction of LTP (5 minute experiments)	pag 63
CHAPTER 4	pag 68
CONCLUSIONS and DISCUSSION	pag 68
4.1 ELF experiments	pag 68
4.1.1. Synaptic transmission	pag 68
4.1.2 LTP	pag 68
4.2 RF experiments	pag 68
4.2.1 Synaptic transmission	pag 68
4.2.2 LTP	pag 69
4.3 Future perspectives	pag 71
REFERENCES	pag 72
APPENDIX A	pag 83
A.1 Synaptic transmission	pag 83
A.2 Synaptic plasticity	pag 85
A.2.1 LTP	pag 85
A.2.2 LTD	pag 86
A.3 References	pag 86

CHAPTER 1

INTRODUCTION

Starting with D'Arsonval studies in 1893 on the biological effects of high frequency currents and then, extended to medical applications of radio waves, the scientific research on the possible harmfulness of non ionising radiation (NIR) for human health have been remarkably increased during the 40ies and, especially after the end of the second world war.

The environment in which we live is more and more permeated of electromagnetic field (EMF) sources: waves emitted from radio and TV antennas; mobile base stations; magnetic field generated by the power lines; etc.. Moreover, besides these sources, we have to take into account numerous EMF sources of other kind, such as radar systems and innumerable radiofrequencies (30 kHz - 300 MHz) or microwaves (300 MHz - 300 GHz) apparatus used both in therapy and diagnosis (e.g. NMR).

Furthermore, during the last year, industry has develop a lot of applications essentially based on the rapid heating of the irradiated materials. The major number of these devices are employed in plastic, car and furniture industries. More recently, high intensity EMF has been employed in foodstuffs field (e.g. microwaves oven) and in paper-make industry.

Despite the enormous advantages of these technologies, a concern rose in the population about the possible risks associated to human exposure to EMF, often leading to an amplification of the risk perception. At present, the safety limits currently proposed (see European Council Recommendations on the limitation of exposure of the general public to electromagnetic fields 0 Hz - 300 GHz, 1999/519/CE, GU 199/59 of 30/7/1999) seem to be able to guarantee a sufficient safeguard of public health. Nevertheless these limits are based on well known interaction mechanisms, i.e. the disruption of physiological metabolism if the electromagnetic (EM) power

deposition in a biological tissue and the related temperature increase are too large. However, this occurs, for the radiofrequencies (RF), at specific absorption rates (SAR) above 4 W/kg (Foster K.R. et al., 1998; Foster K.R. et al., 2000), whereas, for extremely low frequencies (ELF) the thermal effects are always negligible. The body of the existing scientific literature suggests that, according to several experimental findings (Adey W.R., 1999), attention should be paid to exposure intensities close to, or below, the safety limits, mainly in the case of medium/long term exposure. Moreover, there is a sufficient amount of experimental evidence indicating the existence of non-thermal biological effects, in particular for ELF fields (Repacholi M.H. and Greenebaum B., 1999; Litvak E. et al., 2002; Bersani F., 1999). Many studies, including our past long experience, have shown that ELF-pulsed magnetic fields are able to produce biological effects on in vitro cell systems, such as lymphocytes, fibroblasts and myocardial cells (Ventura C. et al, 2000; Bersani F. et al., 1997; Cadossi R. et al., 1992; Cossarizza A. et al., 1991; Cossarizza A. et al., 1989a; Cossarizza A. et al., 1989b). These effects, due to the ELF are certainly non thermal and this opens the question of how these effects can be explained. This is a point of large debate in the scientific literature and represents a real scientific challenge, since the energy involved in the interaction between EMFs and biological targets are of the same order of magnitude or less than the thermal energy (the so called "kT problem") (Adair R.K., 1991). In the last years some hypotheses have been proposed in order to answer this question, including various resonance-based models (Liboff A.R., 1997; Kruglikov I.L. and Dertinger H., 1994; Lednev V.V: 1995), quantum mechanics-based approaches (Chiabrera A. et al., 2000) and specific models for neural cells based on the Hodgkin-Huxley-type excitable membrane description (Apollonio F. et al., 2000). Recent findings demonstrate that neurons are sensitive to EMFs (see for refs. Tattersall J.E. et al., 2001; Mausset A.L. et al., 2001). Moreover, it has been shown that in many animals there is a sort of magneto detection ability and that in some cases this can be related to

the functional activity of specific structures and cells in the brain (Nemec P. et al., 2001; Brown K., 2001). For all tissues and organs is urgent to define exposure risk parameters, for both risk assessment and social security.

In particular, the nervous tissue, being able to convert different energies in biological signals and having a particular vulnerability to lifespan events due to its perennial nature, could represent a preferential model to study long-term effects due to accumulation of single stimuli that are not harmful when applied for short time, but that can become “toxic” with a chronic exposure.

Mobile telephony has further urged the study of EMF effects on neurons, since for the first time the source of RF is very close to the brain. Several studies suggest that may interact with some cognitive processes. In particular, recent evidences indicate that both extremely low frequency (50-60 Hz) EMFs (Kavaliers M. et al., 1993; Lai H., 1996; Lai H. et al., 1998; Sienkiewicz Z.J. et al., 1998) and RF EMFs emitted by GSM cellular phones (900-1800 MHz) (Koivisto M. et al., 2000; Preece A.W. et al., 1999; Krause C.M. et al., 2000) can interact with some learning and memory processes in humans and animals. Nevertheless, the molecular basis of this interaction is still unknown, and some of these studies are controversial and have not been confirmed by other authors (D’Andrea J.A. et al., 2003).

For these reasons, at present, the study of EMF effects on nervous cells is of primary importance in the bioelectromagnetic research field. In particular, one of the most intriguing aspects of these studies is devoted to understand the molecular and biophysical mechanisms by which low intensity EMF fields can modify some biological functions in cells. To this aim, neurons seem to be a particularly important biological model, both when studied in isolation and within their connectivity in the brain.

It is now widely assumed that memory formation depends on modulation of the strength of synaptic connections. Several neuronal functions involved in synaptic plasticity (neurotransmitters release, enzyme activation, intracellular mechanisms of signal transduction

and gene expression) depend on calcium influx through the plasma membrane. Since it has been demonstrated that EMFs can, in some circumstances, affect the mechanisms controlling the cytosolic calcium concentration (Liburdy R.P. et al., 1993; Karabakhtsian R. et al., 1994; Fanelli C. et al., 1999; Tonini R. et al., 2001), one might suppose that this effect might contribute to the observed interactions with learning and memory processes. However, this hypothesis has not been confirmed to date. Moreover, recent studies have shown that some of the intracellular mechanisms of signal transduction involved in synaptic plasticity, such as the formation of cyclic AMP (Varani K. et al., 2003), the activity of PKC (Holian O. et al., 1996) and the binding of CREB with DNA (Zhou J. et al., 2002), might be profoundly affected by EMF. Moreover EMF reduced the ability of serotonin (5-HT) of inhibiting the adenylyl cyclase activity (Massot O. et al., 2000), and consequently the efficacy of the feedback inhibition of 5-HT on its own release. The 5-HT_{1b} receptor appeared desensitized, probably because of a conformational modification. EMF also interact with signal transduction mechanisms not directly related to memory formation.

Another relevant target potentially modified by EMFs is the cholinergic system, which is involved in the modulation of both synaptic plasticity and memory formation, as demonstrated by a large body of experimental and clinical evidence, mostly related to Alzheimer disease (Ibach B. and Haen E., 2004). It has been shown that EMFs reduce cholinergic activity in hippocampus, a brain region involved in the formation of declarative memory ((Longo F.M. et al., 1999). Furthermore, it has been demonstrated that EMFs can affect levels and activity of growth factors ((Lai H. and Carino M., 1999), which play an important role in memory formation. It seems reasonable to suppose that also EMFs effects on signal transduction pathways, on the cholinergic system and on growth factors may be involved in the observed deficits in learning.

The most studied form of synaptic plasticity, which is widely accepted as an *in vitro* model of memory formation, is the long-term

potentiation of synaptic strength (LTP), first described by Bliss and Lomo (1973) in the hippocampal formation (for physiological details see Appendix). Subsequent studies have demonstrated that LTP is a convenient experimental tool to investigate the molecular mechanisms underlying memory formation, and can also be induced in several other brain structures. In particular, this phenomenon has recently been observed in the perirhinal cortex (Bilkey D.K., 1996), a transitional cortex which projects to the hippocampal formation (Burwell R.D. and Amaral D.G., 1998).

The perirhinal cortex is a portion of cerebral cortex lying in the medial temporal lobe, along the caudal portion of the rhinal sulcus (Fig. 1); it includes two distinct cytoarchitectonic areas, named area 35 and 36 (Amaral D.G. et al., 1987; Burwell R.D. et al., 1995) and has strong and reciprocal connections with widespread cortical sensory areas and with other memory-related structures, including the hippocampal formation, the entorhinal cortex and the amygdala (Suzuki W.A., 1996).

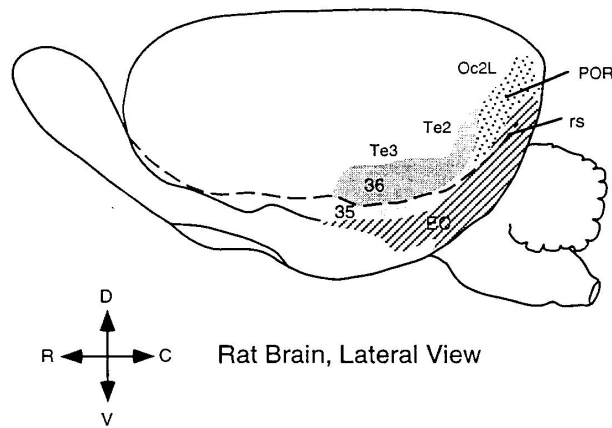

Fig. 1: Lateral surface view of the rat brain showing borders of the entorhinal, perirhinal, and parahippocampal/postrhinal cortices. Perirhinal cortex corresponds to areas 36 and 35. RS: rhinal sulcus; POR: parahippocampal/postrhinal cortices. Te2, Te3: temporal cortical areas 2 and 3; Oc2L: secondary visual cortex (From Burwell et al., 1995).

As for other brain structures, the role of the perirhinal cortex has been defined using specific lesions. In both rats and monkeys, perirhinal cortex lesions result in recognition memory deficits (Gaffan D. and Parker A., 1996; Gaffan E.A. et al., 2004; Zola S. M. et al., 1989). Mumby D.G. and Glenn M.J. (2000) reported that the consolidation of an object discrimination task was impaired in perirhinal cortex lesioned rats. Further evidences of the significant role of perirhinal cortex in visual discrimination learning are provided also by other studies, (Wiig K.A. et al., 1996; Liu P. and Bilkey D.K., 1999; Zironi I. et al, 2001; Squire L.R. and Zola S.M., 1996).

Interestingly, a damage to this cortex is particularly critical to object recognition, not only in relation to visual, but also to tactual stimuli (Suzuki W.A. et al., 1993).

The perirhinal cortex is also involved in visual associative learning and consolidation, since rats with lesions in this cortex show severe impairments in both anterograde and retrograde retention of association of visual stimuli (Bunsey M. and Eichenbaum H., 1993). Finally, the perirhinal cortex is involved in fear conditioning, as post-training perirhinal cortex lesions impair the conditioning to visual, auditory and contextual conditioned stimuli (Campeau S. and Davis M., 1995; Corodimas K.P. and LeDoux J.E., 1995).

It is interesting to note that in rodents, as well as in primates and humans, the perirhinal cortex is located in the temporal lobe, i.e. the brain area nearest the cellular telephone during its use. For this reasons it seems to be a particularly valid experimental model for the study on brain activity.

1.1 AIM OF THE RESEARCH PROJECT

Aim of this research project was to verify possible effects of EMF, both ELF (using different intensities) and RF (different signals and different SAR values), on rat perirhinal cortex slices by the extracellular field potential recording electrophysiological technique.

The different EMF signals and intensities have been chosen according to their relevance in everyday life and in their possible social and environmental framework.

To this end the following endpoints have been investigated:

1. EMF effects on synaptic transmission

Constant-current square pulses have been applied in order to evoke the basal synaptic response and the stimulus intensity was adjusted to produce 50% of the maximal field potential (FP) amplitude.

After 20 min of stabilization of the synaptic response, slices have been exposed to ELF EMF (50 Hz, 1.0 or 2.3 mT intensity) or to RF EMF (900 MHz GSM or CW, SAR 2 W/kg or 4 W/kg) for different periods of time. The temperature was monitored with a thermo resistor with a 0.1 °C sensitivity.

2. EMF effects on LTP

Constant-current square pulses have been applied in order to evoke the basal synaptic response and the stimulus intensity was adjusted to produce 50% of the maximal FP amplitude. Slices have been exposed to EMF (with the same signals as before, aim 1) before or after the induction of the LTP. LTP is defined as an increase in the peak amplitude of the FP > 10 % with respect to the base line. To induce LTP in the perirhinal cortex a stimulation with a “theta” frame was used (four sets of "theta patterned" stimulation delivered 15 s apart, each set comprising 10 bursts of 5 pulses at 100 Hz, inter-burst interval 150 ms) (Bilkey D.K., 1996).

In order to perform these experiments **particular exposure systems have been designed and realized** on purpose.

These set ups were able to allow the exposure to EMF simultaneously to the electrophysiological measurements. In this way a real-time analysis of the possible EMF effects was possible. The exposure systems have been well characterized with a very precise dosimetry calculated by computational methods and validated by experimental measurements.

CHAPTER 2

MATERIAL AND METHODS

2.1 ELF EXPOSURE SYSTEM

For the ELF experimental phase a system of coils set in Helmholtz configuration (two identical circular coaxial coils positioned at a distance equal to the radius) was implemented. This system has mainly been chosen to achieve a good compromise between magnetic field homogeneity and accessibility to the biological sample, being this characteristic a necessary requirement for the electrophysiological measurements. This exposure set up configuration allows to perform simultaneously the electrophysiological recordings and the sample exposure to EMF.

The electronic devices used in the signal generation part of the set up are the following:

- Function generator Beckman FG3A set in such a way to produce a 50 Hz sinusoidal signal,
- “home made” current amplifier suitable for low resistive load
- MeterMan 34XR multimeter to monitor the current passing through the coils

Each coil is wound by a pair of independent parallel wires, with different outputs each, so that, according with the different connections, the current can either flow in the same direction “wound configuration” (active or exposure configuration) or in the opposite direction “counter-wound configuration”. In the latter case the magnetic fields produced by counter-wound coils cancel each other, allowing a “true” sham system, in which the current and the power dissipation are the same as in wound configuration, but the magnetic flux density is theoretically zero (Kirschvink J.L., 1992). In the real system, due to small differences in the wire turns, the total magnetic flux density was not exactly zero, but it never exceed 1/100 of the

corresponding value when the coils are set in “wound configuration” for the same current flow. In order to easily switch from “sham” to “active” configuration and vice-versa, a device acting on the wire outputs, has been realized. This “exchanger” (a kind of “black box”) by means of one single switch, that drives automatically a series of relays, connects the different wires in order to obtain the desired configuration.

The function generator produces a 50 Hz sinusoidal signal of a well defined amplitude that can obviously be changed by the experimenter in order to obtain the intensity required. After amplification, the signal “enters” the coils. In order to check the goodness of the amplified signal shape an oscilloscope is connected with the “output test” of the amplifier. The amplified signals generates in the coils an oscillating magnetic field directly proportional to the current density passing through the wires. The current is continuously monitored by an amperometer, placed in series in the circuit. In this way it is possible to check, indirectly, the magnetic field intensity in the coils. In figure 2 the scheme of the ELF EMF exposure set is reported.

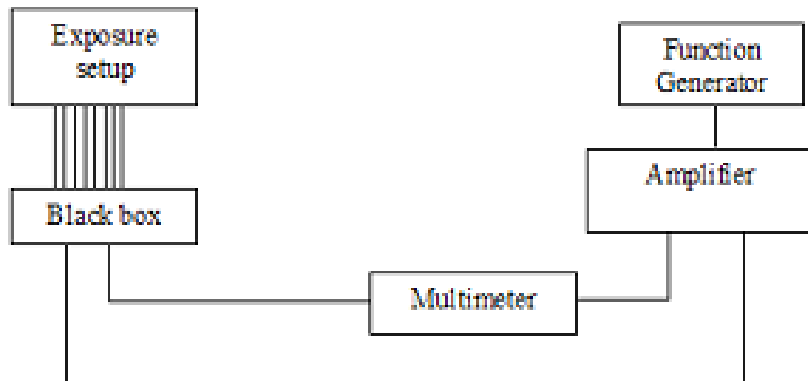

Fig. 2: ELF EMF set up scheme.

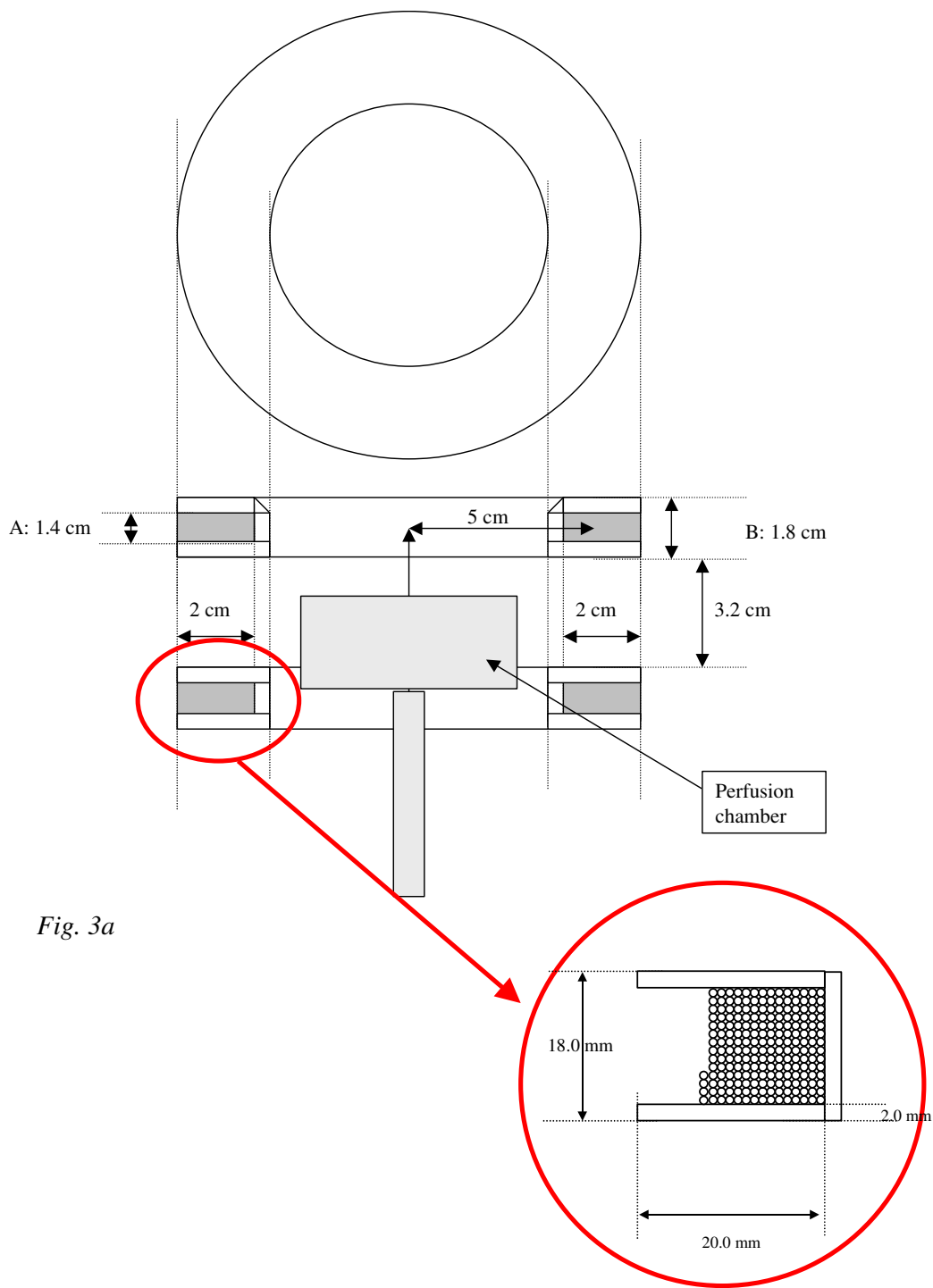

Fig. 3a

Fig. 3b

Fig. 3: Design of the exposure set up. Fig. 3a: Section of the system. Fig. 3b: section of a coil.

Each coil is constituted by 200 turns copper wire (100+100) ($\varnothing= 0.9$ mm; $\rho = 1.69 \cdot 10^{-8} \Omega\text{m}$), wounded on a Plexiglas structure. The total resistance measured is $R_{\text{tot}} = (5.0 \pm 0.1) \Omega$, and the inductance (in active configuration) is $L_{\text{tot}} = (23.2 \pm 0.1) \text{ mH}$. For further details concerning the geometric dimension of the coils, see figure 3.

A dedicate software with Matlab has been implemented able to simulate the magnetic fields produced by the two coils, in order to evaluate, before the realization, both the distribution of the field and its uniformity in the volume of interest (uniformity defined as $(B_{000} - B_{ijk}) / B_{000} * 100$, where B_{000} is the magnetic field intensity in the centre of the system and B_{ijk} is the intensity in the point with coordinates i,j,k).

In figure 4 the distribution inside the system of the magnetic field, generated using a current of 1 A is reported. In Figure 5a, 5b and 5c the zones of 1%, 2% and 5% uniformity (blue colour) are shown, respectively.

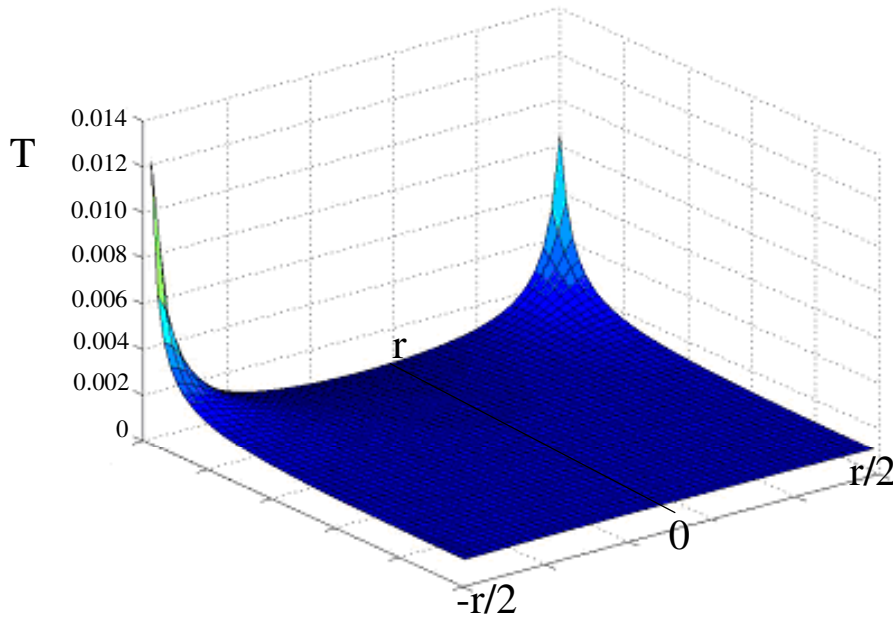

Fig. 4: Magnetic field intensity inside the coils.

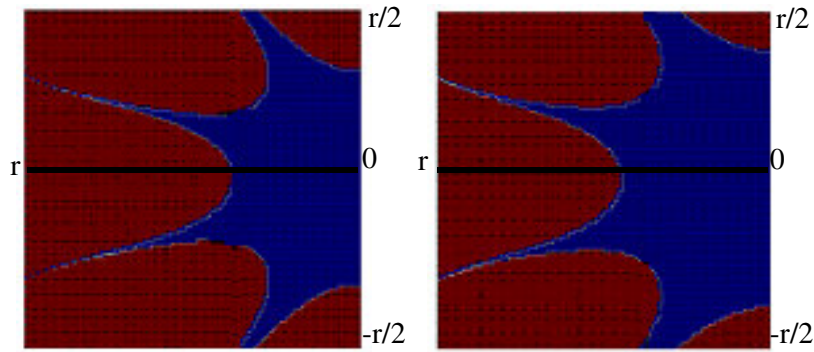

Fig. 5a

Fig. 5b

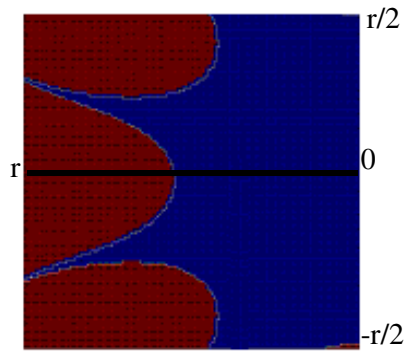

Fig. 5c

Fig. 5: Zones of 1% (Fig. 5a), 2% (Fig. 5b) and 5% (Fig. 5c) uniformity.

Moreover, before the installation of the EMF exposure system, a series of magnetic field measurements were performed in order to evaluate the intensity of AC background magnetic fields and the local geomagnetic field. The AC background MF intensity was measured with a very sensitive isotropic probe (EMDEX - Enertech consultant) and the values obtained ranged between 0.05 and 0.4 μT . The geomagnetic field intensity was measured, along the three axis, with a Gaussmeter (DG7010 FW-Bell) connected to an axial probe: values were between 19 and 33 μT .

The relationship between current intensity, flowing through the wire, and magnetic field inside the coils is reported in a I-B plot (figure 6).

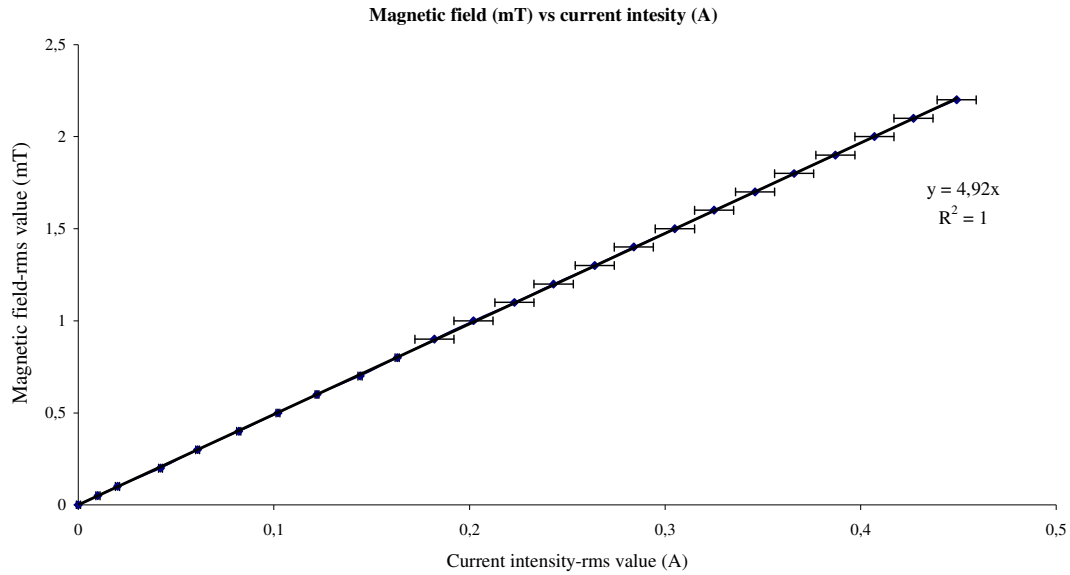

Fig. 6: Relationship between current intensity and magnetic field.

The obtained regression line equation is: $B_{\text{rms}} = 4.92 \cdot I_{\text{rms}}$, where B_{rms} is the root mean square value of the magnetic field intensity and I_{rms} the root mean square current intensity. From this equation we get $I_{\text{rms}} = B_{\text{rms}}/4.92$, from which we can extrapolate the current intensity value corresponding to the magnetic field intensity desired.

The magnetic field uniformity (see above) was verified also by direct measurements. A set of measurements were done inside the coils (in the zone of the exposure system typically utilized during the experiments) at different field intensities. In figure 7a a plot is reported with measurements performed along the z axis of the coil system (from point -2.4 cm to 2.4 cm) at different distances from it along the radius (from 0 to 3 cm). Figure 7b represents the distribution of uniformity at level of 2 % with the measured values;

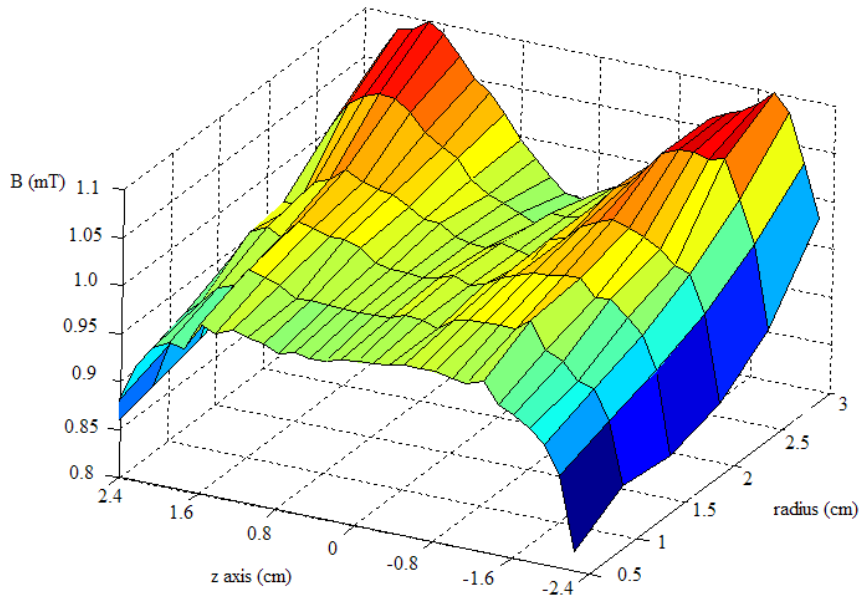

Fig. 7a: Measured magnetic field intensity, produced with a current intensity of 0.20 A.

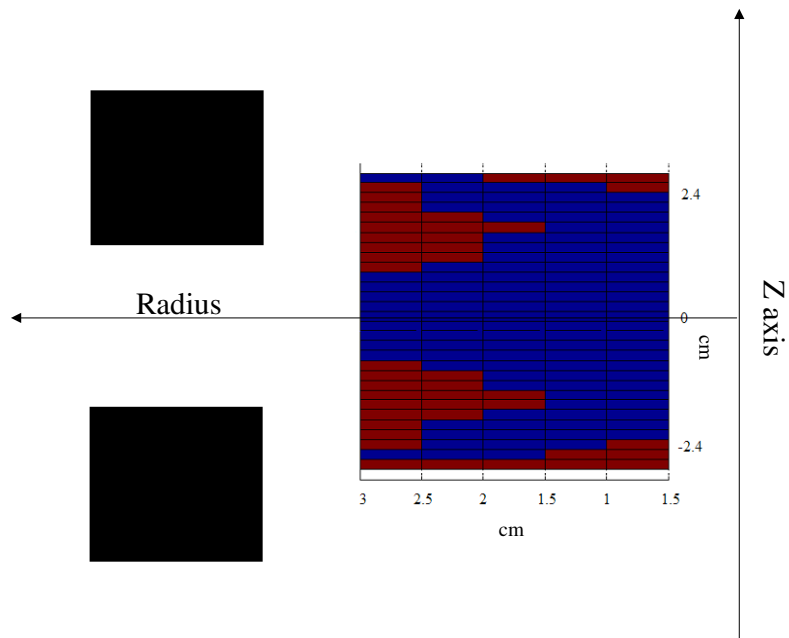

Fig. 7b: Uniformity distribution of magnetic field (produced with a current intensity of 0.20 A). The black squares are the section of the coils. (Not in scale).

For the experiments a sinusoidal 50 Hz magnetic field with two intensities (2.3 mT (rms) or 1.0 mT (rms)) were used.

In figure 8 pictures of the exposure system (Fig. 8a and 8b: coils in extracellular field potential recording set up; Fig. 8c: generation unit).

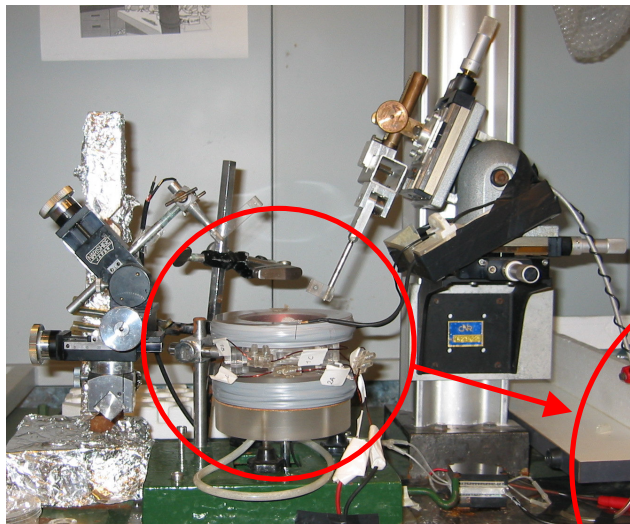

Fig. 8a

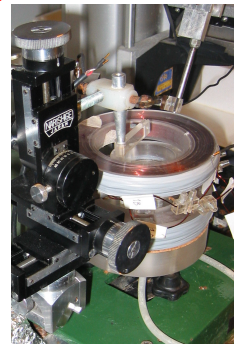

Fig. 8b

Fig. 8c



Fig. 8: Pictures of the exposure system. Fig. 8a and 8b coils in the extracellular field potential recording set up; Fig. 8c. generation unit;

2.1.1 Temperature measurements

Some temperature measurements (couple of Thermistor, VITEK) were performed in order to see if the current passing through the coils could, by Joule effect, affect the temperature in the solution and, as a consequence, within the sample.

No temperature increase due to ELF exposure was revealed in the solution in the perfusion chamber, for 1 hour 2.3 mT exposure, 1 hour 1.0 mT exposure or 30 minutes 2.3 mT exposure. All measured values were inside an interval of 0.5°C over the entire duration of the test. This variation was due to the temperature fluctuations inside the Lab.

2.2 RF EXPOSURE SYSTEM

The set up used for the 900 MHz RF exposure has been designed specifically (Università of Rome, “La Sapienza”) to be used in electrophysiological experiments and, in particular, for experiments dealing with the extracellular field potential recording technique.

It is characterized by a complete automation, wide versatility and easy transportability.

The electronic devices used in the signal generation part of the set up are the following:

- Oscillator Micro Lambda Wireless, Inc. MLOM Serie (Multi-octave bands) YIG tuned oscillators
- Programmable attenuator MCE Weinschel Model 4208
- Amplifier Aethercomm SSPA 0.8-3.2-10
- Bidirectional Coupler Miteq, model CD2-102-402-20S.
- DAQ card 6715 National Instruments
- Power Meter E 4418B Agilent technologies with Power sensor E 9300

The set up is made up of two principal units:

1. the generation unit, dedicated to the generation and control of the EM signal
2. the exposure device.

2.2.1 The generation unit

In figure 9 the block diagram of the system is reported. In blue is the generation unit; in green the unit dedicated to the amplification and the transmission of the signal and, in red, the unit devoted to the monitoring and the real time control of the generated signal. The box in orange represents the exposure system.

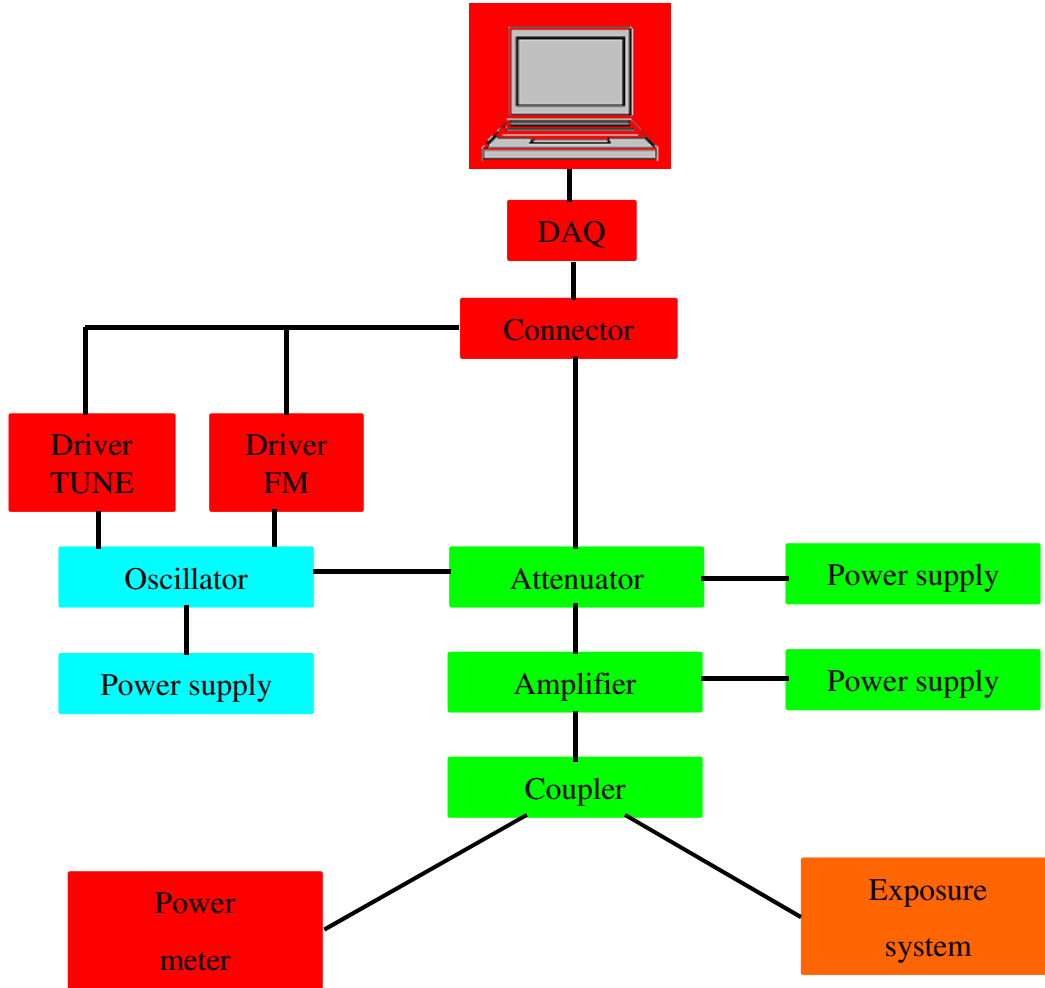

Fig. 9: Block diagram of the exposure system.

The signal, generated by the oscillator, reaches the desired power passing through a programmable attenuator and through a fixed-gain amplifier. Afterwards, by means of a bidirectional coupler, a small fraction, about 1%, of the power transmitted to the exposure device, is collected and measured with a power meter (Molfetta et al., 2003). In figure 10 a picture of the signal generation unit is reported.

The inputs for the oscillator and for the attenuator come from a data acquisition card (DAQ) connected with a portable PC and are calculated by a software implemented in Labview 6.1. The software has an user-friendly interface and allows the user to choose the kind

(Continuous Wave (CW) or Global System for Mobile communication modulated (GSM)), the frequency (from 900 to 2500 MHz) the power of the signal and the duration of the exposure.

The correct working of the single components of the signal generation chain has been experimentally characterized in the ENEA laboratories in Casaccia, Rome.



Fig. 10: signal generation unit

2.2.2 Exposure device

The exposure device consists of a coplanar waveguide (CPW) and its design and realization meet the essential requirements to obtain good-quality bioelectromagnetic experiments (Liberti M. et al., 2006).

The CPW is an open propagating structure presenting an easy accessibility to the exposed biological sample, allowing simultaneously the electrophysiological recordings and the exposure to EMF. Thank to the relatively small geometrical dimensions (22 cm x 10.5 cm x 0.4 cm), it was positioned “inside“ the extracellular field potential recording setup. Actually, the CPW is placed under the objective of the microscope. See figure 11.

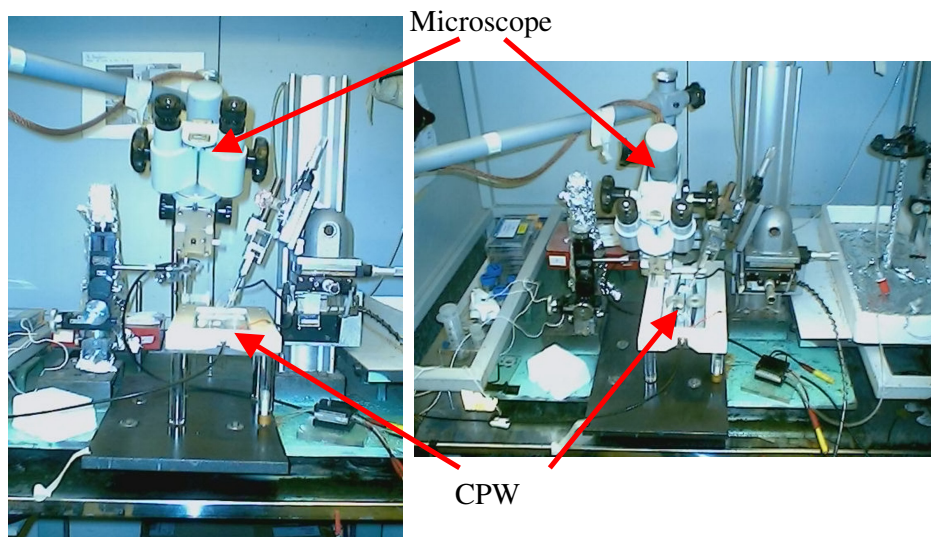

Fig. 11: CPW inside the extracellular field potential recording setup

The CPW is constituted of a dielectric substrate (glass) on which, by a lithographic process, three thin conductive metallic strips (Aluminium chromate) were plated in a way to leave two windows for visualization of the brain slices under microscope. The lateral strips serve as ground (figure 12).

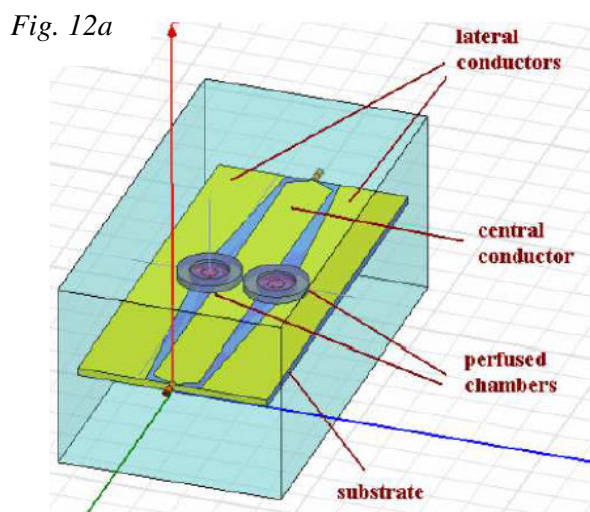

Fig. 12a

Fig. 12b



Fig. 12: Coplanar Wave Guide. Fig. 12a: Scheme of the CPW; Fig. 12b: Pictures of the set up used in the experiments.

The structure has been designed to propagate only the fundamental mode (quasi-Transverse Electromagnetic Mode (TEM)) in which the direction of the electric field is almost parallel to the biological sample

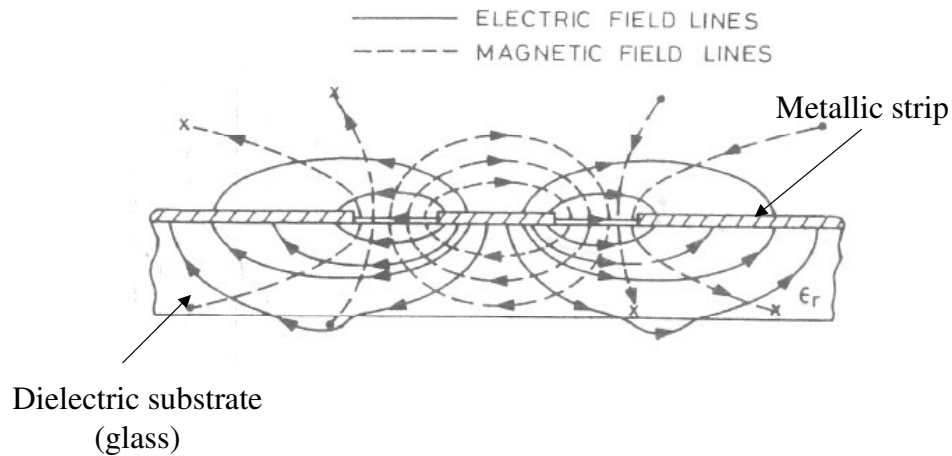

Fig. 13. Propagation mode in the CPW

(figure 13) and, consequently, almost orthogonal to the recording and stimulating electrodes. In this way is possible to minimize the interference of the field with the electrodes.

The absolute value of the electric ($|E|$) and of the magnetic field ($|H|$), for a 1 W input power, have been measured (by the Electronic Engineering group, Università “La Sapienza”, Rome). Measurements have been conducted at the distances of 0.5, 1, 2, 4 and 8 cm from the CPW surface.

Surface map of $|E|$ at 905 MHz, measured at distance of 0.5 cm from the CPW surface, is reported in figure 14. It can be noted that $|E|$ is symmetric with respect to the x- and y-direction and reaches its maximum value on the two visibility windows (represented with black dashed lines).

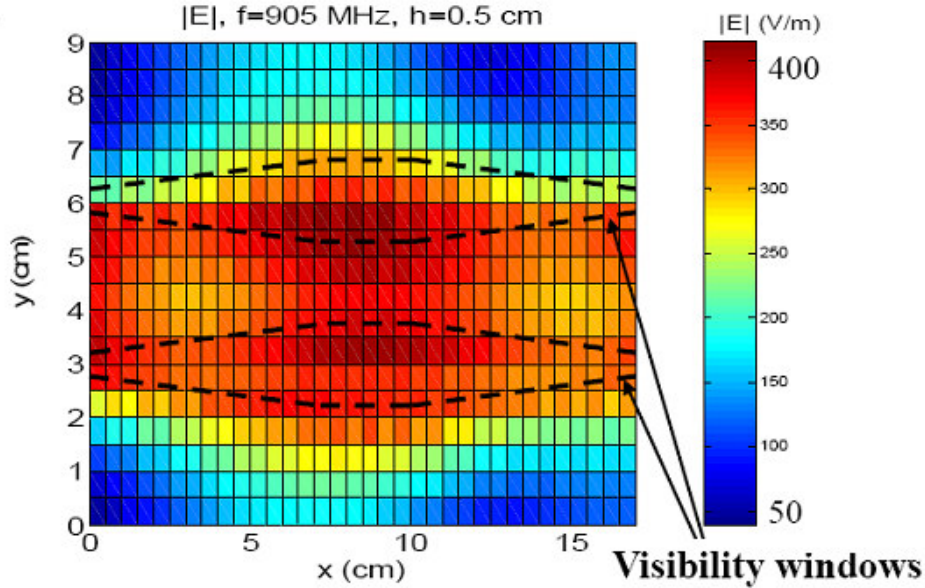

Fig. 14 Surface map of $|E|$ at 905 MHz, measured at distance of 0.5 cm from the CPW surface.

Homogeneity of $|E|$ and $|H|$ fields has been evaluated in the exposure zone. The results show values of maximum percentage difference always lower than 30% (table 1)

	Mean value	Standard deviation	Max percentage difference (%)
$ E $	348.40 V/m	16.46 V/m	13.4
$ H $	2.56 A/m	0.32 A/m	28.4

Tab 1

Also the decay of $|E|$ and $|H|$ was evaluated. A series of field measurements were performed in order to see how fast the intensity of the field, gradually going off from the CPW, decay. For instance, the $|E|$ field, at a level of about 3 cm above the CPW, reaches the 20 % of its maximum value, so that only a minimum interference occurs with external objects distant more than 3 cm from the structure (figure 15).

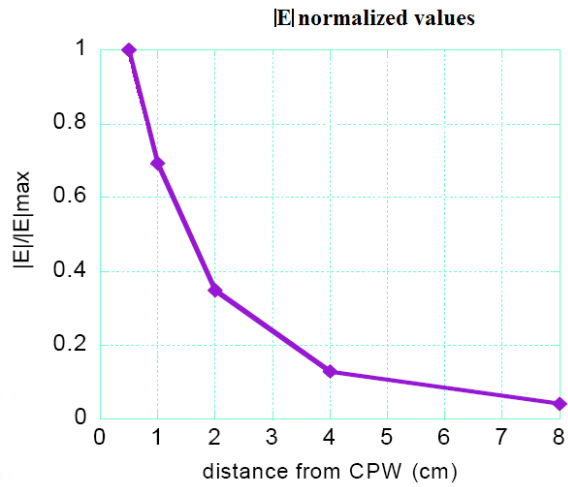

Fig. 15: $|E|$ field normalize value decay. (Pellegrino M. et al., 2005)

Another aspect taken into consideration in the project of the exposure system concerns the perfusion chamber. In order to have an optimal field distribution a new perfusion chamber, of different shape from the usual one, has been realized. The new one, besides the fact that can be positioned on the CPW surface, does not “disturb” the uniformity of the EMF. In figure 16a is reported the “usual” perfusion chamber; in figure 16b the new one.

Fig. 16a



Fig. 16b



Fig. 16: Perfusion chamber. Fig. 16a: “usual”; fig. 16b: “new”.

The efficiency ($SAR/Inc.Power ((W/kg)/W)$) of this exposure system was evaluated by temperature measurements and it was estimated around 11,27 ((W/kg)/W).

During the experimental phase, in order to verify the right responsiveness of the entire setup, before and after each exposure, a series of measurements of incident power (to check the generation part) and of reflected power (to check the CPW) were performed.

2.2.3 Temperature measurements

A series of temperature measurements (couple of Thermistor, VITEK) was performed.

Preliminary results indicated that for a 2 W/kg CW 1 hour exposure did not increase the temperature in the solution in a appreciable way. However, much more tests are needed to totally exclude, in a reasonable way, temperature increase due to RF exposure.

2.3 EXTRACELLULAR FIELD POTENTIAL RECORDING TECHNIQUE

The extracellular field potential recording technique permits the measurements of the extracellular field potentials generated by a stimulating electrode in slices of nervous tissue.

With this method it is possible to evaluate the characteristics of the neurons that are in the field of influence of the stimulation, looking, in an indirect way, at the possible changes occurring in the post synaptic action potential. Actually, the extracellular field potentials mirror the local changes in the transmembrane potential and in the transmembrane currents.

A diagram in fig 17 showing a field potential recording.

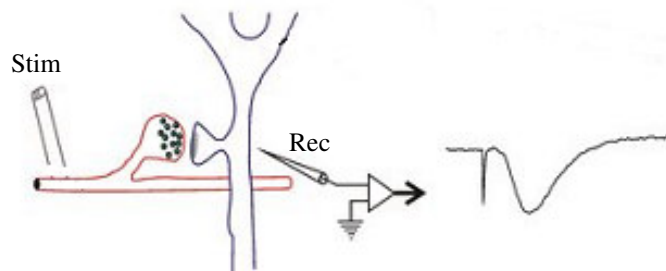

Fig. 17: Diagram of field potential recording

At the left is a schematic diagram of a presynaptic terminal and postsynaptic neuron. This is meant to represent a large population of synapses and neurons. When the synapse, after a stimulation, releases the neurotransmitters to the postsynaptic cell, it opens the receptor channels. The net flow of current is inward, so a current sink is generated. A nearby electrode detects this as a negative potential.

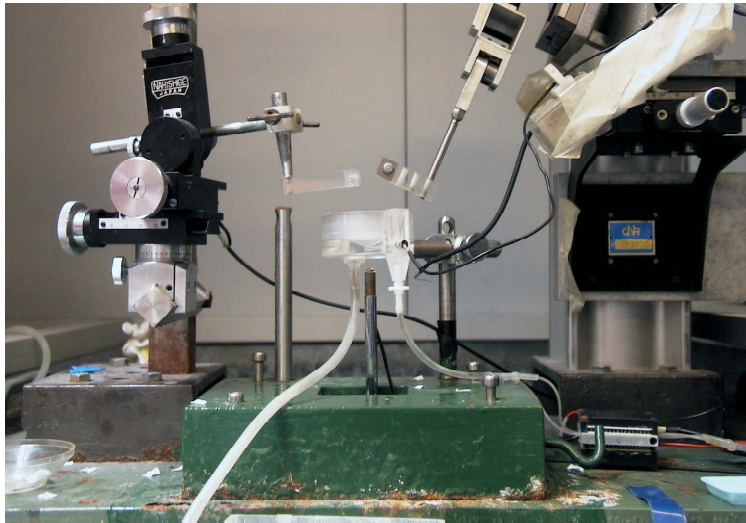

Fig. 18: Picture of extracellular field potential recording set up.

A stimulating electrode, generating a well defined signal with a determined (by the experimenter) amplitude, is positioned in a precise zone of the slices in a submersion recording chamber perfused with artificial cerebro-spinal fluid (ACSF), whose temperature was controlled by a Peltier-device.

At a certain distance form the stimulating electrode, by means of a micromanipulator, the recording electrode is positioned. It is constituted by a silver (Ag) wire coated with a composite of Ag and silver-chloride (AgCl) in a glass micropipette.

The micropipette is previously “pulled” with a flaming/brown micropipette puller and micro-forged in order to obtain a tip with a diameter of about some micrometers, then is filled with an electrolytic solution(resistance of some MegaOhm). This electrode records the signal, which is a kind of summation of all the potentials generated by the excited neurons close to the recording electrode.

The extracellular microelectrode is connected to a DC current amplifier that captures the bioelectrical signal. The circuit is closed with a third electrode (reference electrode) connected to the ground from one end and inserted in the perfusion chamber from the other. During experiments with RF EMF the grounded electrode is connected with the solution in the perfusion chamber by means of an

agar bridge to reduce the interference with the EMF signal and, as consequence, to have less noisy recordings.

Field potentials, passed through a pre amplifier to another more powerful amplifier, are transformed by an analogical/digital converter in a digital form and visualised on a computer (acting as an oscilloscope). In figure 18 a pictures of the set up use in our experiments is shown; in figure 19 a schematic representation of the set up is reported.

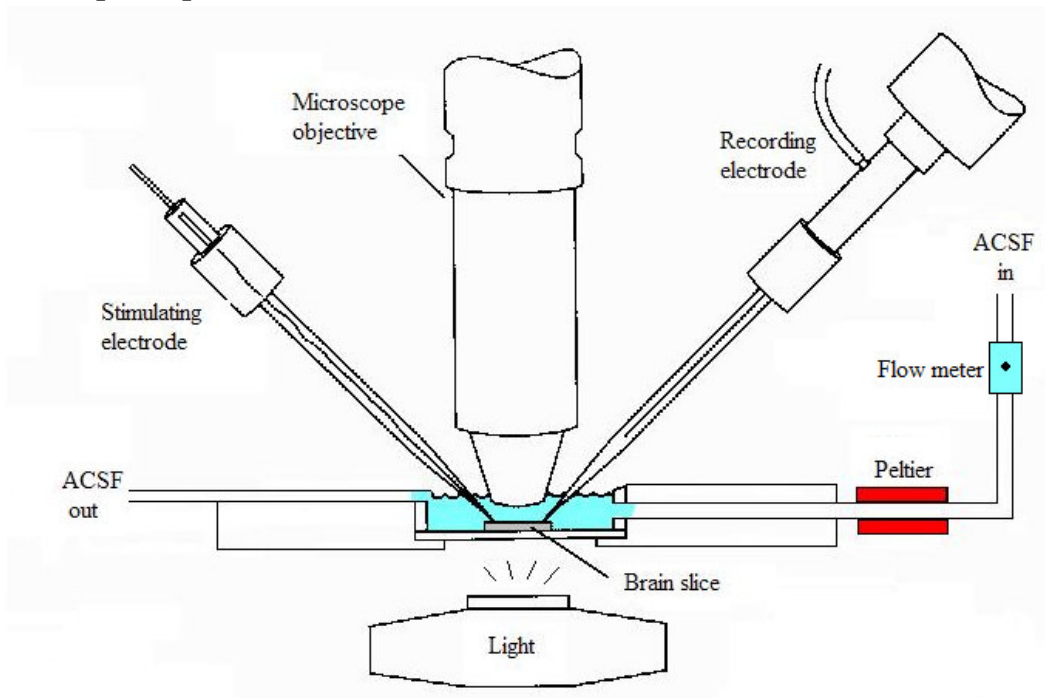

Fig. 19: Extracellular field potential recording set up scheme.

Operatively, after cutting (see below), slice is immersed in the perfusion chamber and the stimulating electrode is inserted. The stimulator can be moved in micrometric manner in order to “find” a good response, both in term of peak amplitude and latency.

In order to be sure to study the synaptic potential, peak latency, i.e. the “distance” between the artefact and the peak, must be equal to about 4 milliseconds, which is the average duration of one chemical synapsis (Kandel, 1991).

After detecting a response (potential), a series of stimulation of growing intensity is delivered in order to verify the effective slice response to the stimulus. A kind of “saturation curve” is realised: at the beginning the potential amplitude varies proportionally to the intensity of the stimulus, then reaches a maximum. The experiment goes on with a stimulation, every 30 seconds, equal to the 50% of the maximal response. In this way,

a) a more stable situation can be maintained for all the duration of the experiment because the slice is less stressed,

and moreover,

b) both increases and decreases in potential amplitude can be detected.

The data used for the analysis are the field potential peak amplitudes.

2.3.1 Slice preparation and electrophysiological measurement

In these experiments we used horizontal brain slices including the perirhinal cortex, prepared from Sprague Dawley male rats aged 20 to 50 days. The animals were treated in accordance with the European Community guidelines on animal care, and the experimental protocols were approved by the Ethical Committee of the University of Bologna.

All efforts have been made to minimize animal suffering and the number of animals used. Rats were anaesthetized with halotane and sacrificed. Brains were quickly removed and immersed in cold (4°C) low-sodium, high-sucrose solution, bubbled with a mixture of 95% O₂ and 5% CO₂ at pH 7.4. Horizontal slices 400 µm thick were cut using an oscillating tissue slicer (FHC, U.S.A) and stored at room temperature, submerged in ACFS, bubbled with a mixture with 95% O₂ and 5% CO₂ at pH 7.4.

After 1 hour (incubation time), during which the cutting stress is recovered, slice is moved to the submersion recording chamber perfused (3 ml/min flux) with ACFS at 34 °C. Then, before starting the recordings, at least 30 minutes are left in order for the slice to fit the temperature.

During the whole experiments, bath temperature was kept at 34°C. Field potentials (FPs) evoked by horizontal pathways stimulation were derived by an extracellular microelectrode (glass micropipette filled with 0.25 M NaCl, 2-5 MΩ) connected to a DC current amplifier by an Ag/AgCl electrode. The microelectrode was placed in layer II-III of the tissue located immediately adjacent to the rhinal fissure. The stimulating concentric bipolar electrode (70-80 KΩ) was placed in layer II-III, approximately 500 μm from the recording electrode, in rostral direction (figure 20).

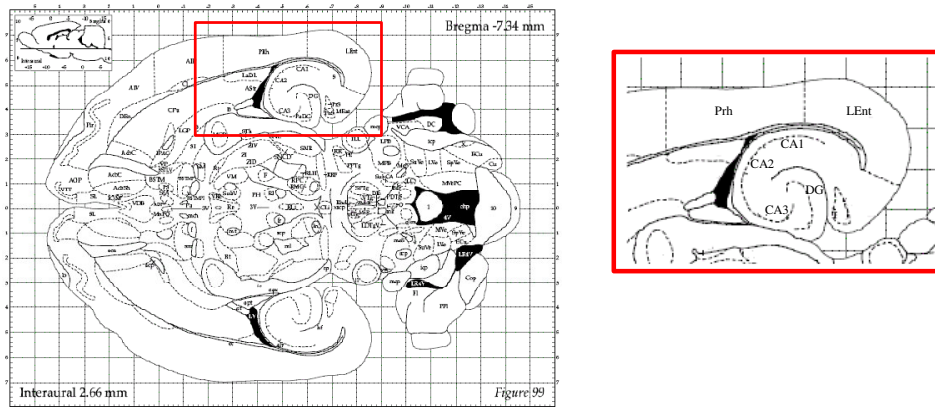

Fig. 20: Representation of an horizontal rat brain section and position of the electrodes (based on the Atlas of Paxinos and Watson, 1998). Prh: perirhinal cortex; LEnt: lateral entorhinal cortex; DG: dentate gyrus.

Bioelectrical signals were amplified, displayed on an oscilloscope, digitalized by a DigiData 1200 A/D converter (Axon Instruments) and recorded using Axoscope 8.0.

Data are then analyzed using Clampfit (Axon Scope). Software gives the peak value potential (for each sweep) as difference between the average of values just before the stimulation (in red in figure 21) and the minimum value of the same sweep (blue dot in figure 21).

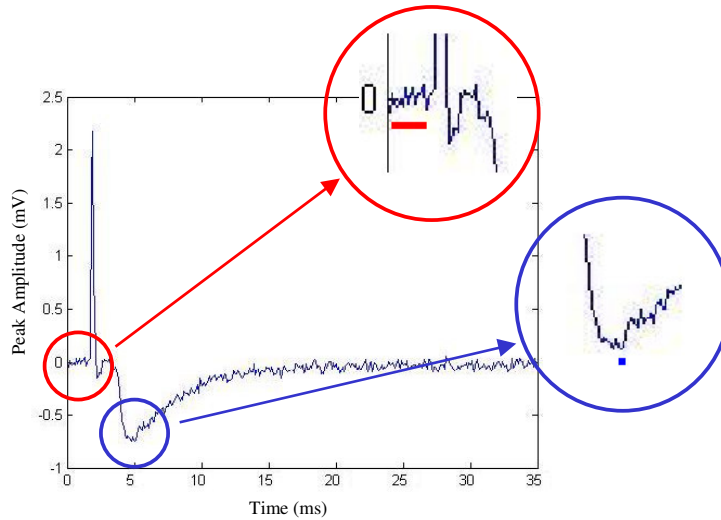

Fig. 21: “...peak value potential (for each sweep) as difference between the average of values just before the stimulation (in red in figure) and the minimum value of the same sweep (blue dot in figure)...”.

Two different protocols were used both for ELF experiments and RF experiments: one for the study of the basic synaptic transmission and one for the study of the LTP.

2.3.2 Basal Synaptic Transmission

Constant-current square pulses (0.2 ms, 0.033 Hz) were applied in order to evoke the basal synaptic response (see in figure 22a for the shape of the stimulus pulses and in 22b for an example of the recorded potential) and the stimulus intensity was adjusted to produce 50% of the maximal peak amplitude.

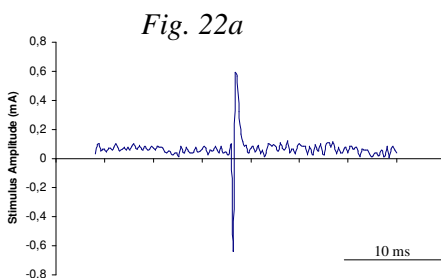

Fig. 22a

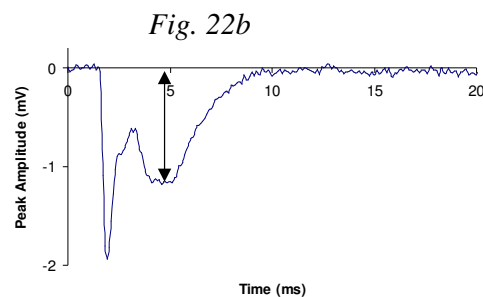

Fig. 22b

Fig. 22a: Shape of the stimulus pulses; Fig. 22b: example of the recorded potential of the recorded extracellular field potential trace..

2.3.3 Long Term Potentiation

LTP was induced by theta burst stimulation (TBS, four sets of "theta patterned" stimulation delivered 15 s apart, each set comprising 10 bursts of 5 pulses at 100 Hz, interburst interval 150 ms, see figure 23) (Bilkey D.K., 1996; Aicardi G. et al., 2004) after stabilization of the synaptic response.

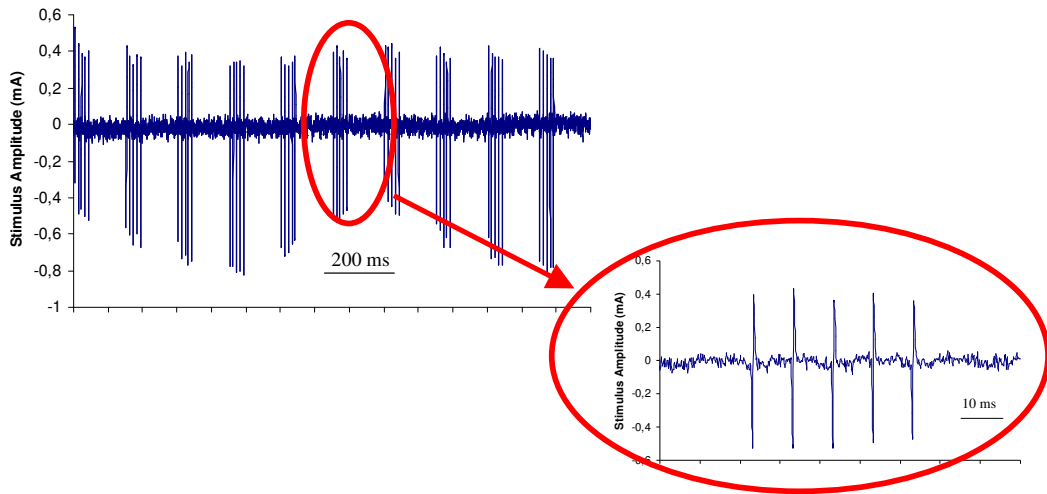

Fig. 23: TBS pattern.

LTP is defined as an increase in field potential amplitude of $>10\%$ (Ziakopoulos Z. et al., 1999) (See figure 24 for an example of the potentiated field potential peak).

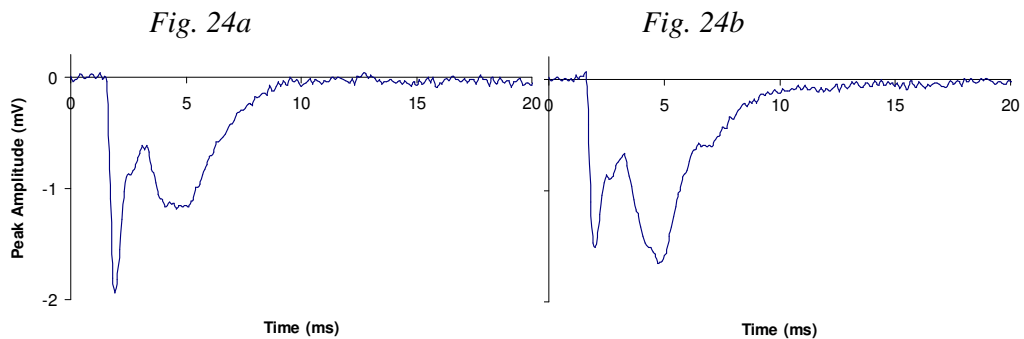

Fig. 24a: Before TBS; fig. 24b: After TBS.

Only slices in which there was an increase of peak amplitude $>10\%$ were considered in the analysis.

2.4 EXPOSURE CONDITIONS

2.4.1 ELF experiments

In order to evaluate possible effects of 1 hour, sinusoidal 50 Hz ELF EMF exposure, on basic synaptic transmission two magnetic field intensities were used: 1.0 mT e 2.3 mT.

These values have been chosen because previous studies have shown effects on central nervous system, both in vivo and in vitro, around these magnetic field intensities (Espinosa J.M. et al., 2006; Massot O. et al., 2000; Bawin S.M et al., 1996; Reyes-Guerrero G. et al., 2006; Bao X. et al, 2006; Jelenkovic A. et al., 2005).

Only experiments in which there was no appreciable drift, at most 4 values outside the interval 90-110% in the 20 minutes before the stimulation, were included in the pooled data. The base line (BL) was normalized to the average of the values corresponding to the last 10 minutes before the exposure. After the exposure the slice was maintained in the perfusion chamber and stimulated for 25–30 minutes more, in order to have the “recovery” condition. See figure 25.

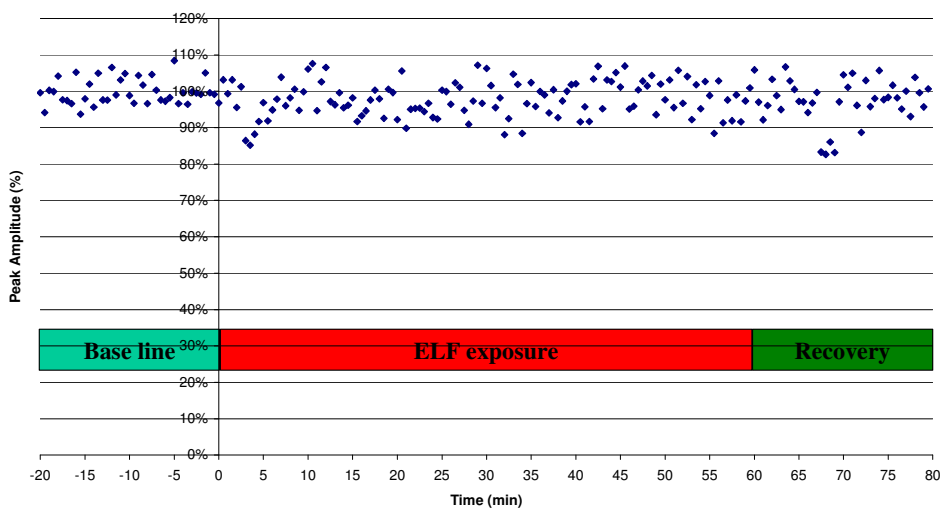

Fig. 25: Protocol for ELF transmission experiments.

Control experiments were performed. In this condition the field was turned off. The total duration of the experiments were always the same in the two conditions.

In order to evaluate possible effects of sinusoidal 50 Hz ELF EMF exposure on the maintenance of LTP the following protocol was applied:

20 minutes of stable (see upon) BL, theta burst stimulation to induce LTP, after 40 minutes the exposure to 2.3 mT started, lasting for 30 minutes. Then, slice was maintained in the perfusion chamber and stimulated for 30 minutes more, in order to have the “recovery” condition. (figure 26)

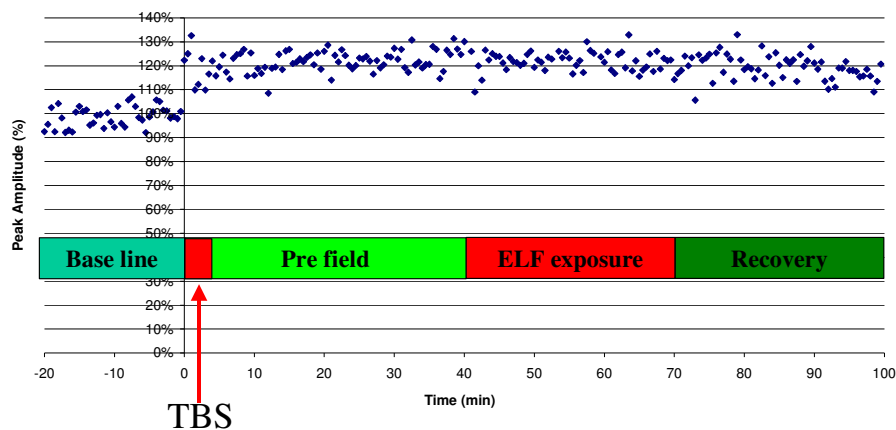

Fig. 26: Protocol for ELF LTP experiments.

Only experiments in which there was no appreciable drift, at most 4 values outside the interval 90-110% in the 20 minutes before the stimulation and in which the peak amplitude of the potentiation was greater than 10 % of the peak recorded in BL condition, were included in the pooled data. The BL was normalized at the average of last 10 minutes before the TBS.

Control experiments were performed with the same protocol but without field exposure. Obviously, the control slice considered for the analysis were only those that fulfilled the same requirements needed for the exposed ones.

Before data coming from ELF experiments were ready for analysis, a preprocessing of the recorded sweeps was needed. The traces, actually, presented a 50 Hz sinusoidal noise similar, as expected, to the signal used; this was due to the interaction between magnetic field and recording electrode.

The “cleaning” was performed “off-line” by means of a dedicated software, specifically implemented. The “rationale” of the software is the following: for each exposed sweep (total duration 30 s), the last 100 ms (corresponding to 5 period of the sinusoidal 50 Hz noise) were

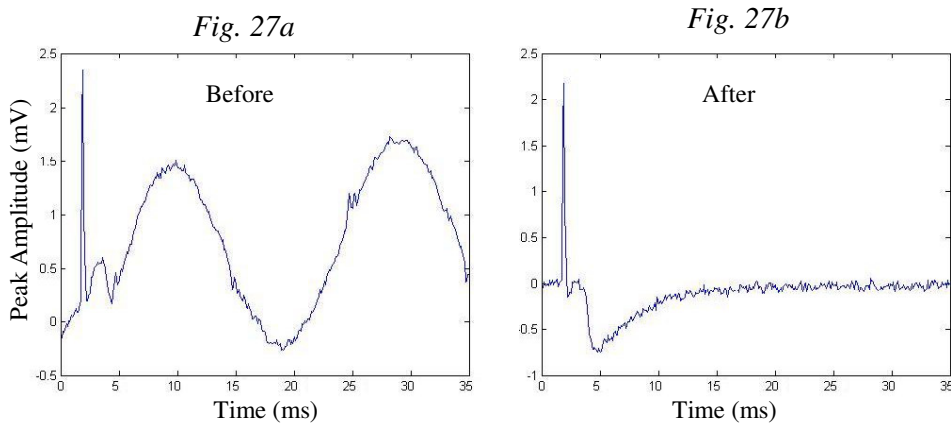

Fig. 27a sweep with noise; Fig. 27b same sweep after the “cleaning”.

taken and shifted at the beginning of the trace. After a procedure of phasing, the two curves were “subtracted” each other. (see figure 27a, before noise subtraction and figure 27b, after noise subtraction).

2.4.2 RF experiments

In order to evaluate possible effects RF EMF exposure on basic synaptic transmission two protocols were used: a. RF EMF exposure for 1 hour; b. RF EMF exposure for 5 minutes;

a. RF EMF exposure for 1 hour using CW and SAR = 2 W/kg. The total duration of the experiments and the requirements that must be fulfilled by the slices to be included in the analysis were the same as specified before for the ELF experiments dealing with synaptic

transmission. Experimental scheme is equal to the one used for the ELF transmission experiments (see figure 25).

Control experiments were performed; slices were recorded using the “new” perfusion chamber (see the “Radiofrequency exposure system” section), but with the CW RF field turned off.

b. RF EMF exposure for 5 minutes. Two different electromagnetic signals with different SAR values were used: CW 2 and 4 W/kg and GSM 2 and 4 W/kg.

Only experiments in which there was no appreciable drift, at most 2 values outside the interval 90-110% in the 10 min before the stimulation, were included in the pooled data. The BL was normalized to the average of the last 5 minutes before the exposure.

After the exposure the slice was maintained in the perfusion chamber and stimulated for 10 minutes more, in order to have the “recovery” condition (figure 28). Again, control experiments were performed.

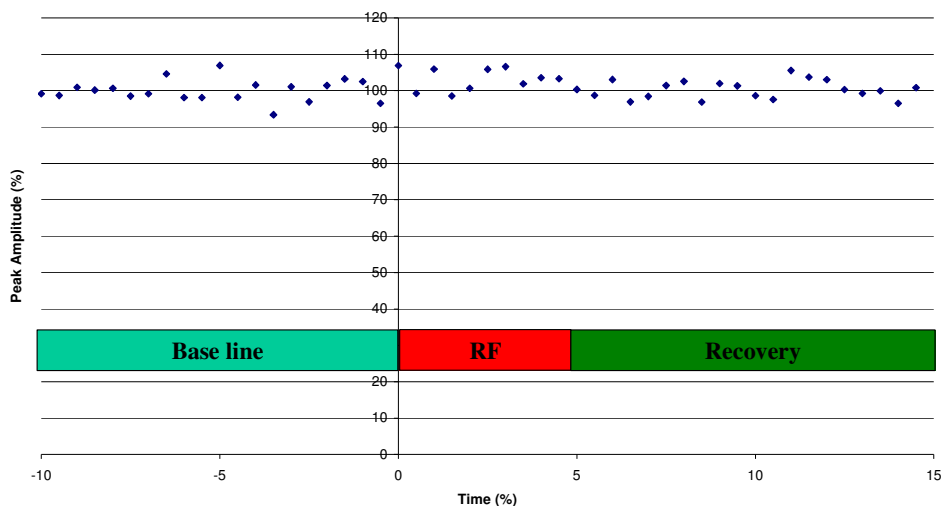

Fig. 28: Protocol for 5 minutes, RF transmission..

The evaluation of possible effects of RF EMF exposure on the induction of LTP is another target of this research. The TBS was delivered 10 minutes after the end of RF-exposure (figure 29). two SAR values were used for the GSM signals: 2 and 4 W/kg. After TBS the slice was recorded for at least 15 minutes

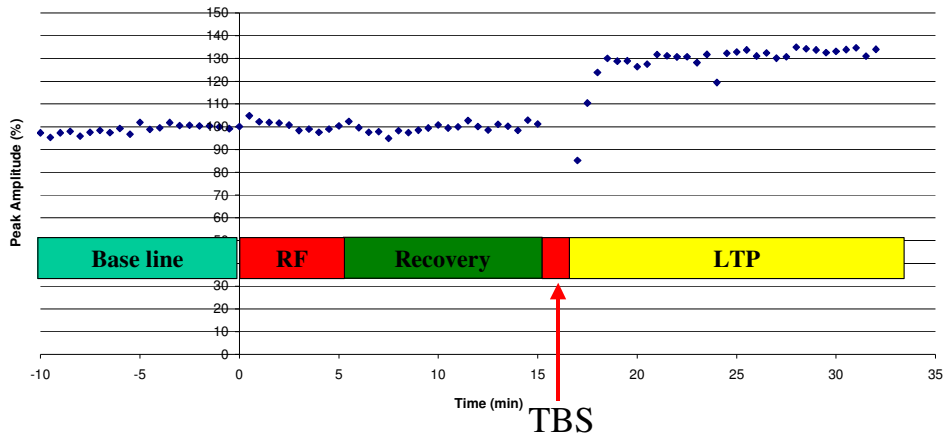

Fig. 29: Protocol for 5 minutes, RF LTP experiments.

Slices inserted in the pooled data were those in which there was no appreciable drift, at most 2 values outside the interval 90-110% in the 10 min before the exposure and in which the peak amplitude of the potentiation was greater than 10 % of the peak recorded in BL condition. The BL was normalized at the average of last 5 minutes before the exposure.

Control experiments were performed with the same protocol but without field exposure

2.5 STATISTICAL ANALYSIS

For each end-point studied, an “a priori” statistical power analysis was performed. The statistical power is denoted by $(1-\beta)$, where β is the type II error, namely the probability of failing to reject the null hypothesis when it is false. Conventionally, an acceptable level of power was considered as equal or greater than 80 %.

Starting from pilot studies, used to determine the variance of the data, the number (n) of samples to use in the experiments was calculated for each end-point studied. The formula used to calculate n, for “a priori” power of F test in ANOVA or in 2 way ANOVA was:

$$n = \frac{\Phi^2 \cdot 2 \cdot p \cdot s_e^2}{\delta^2}$$

where:

n = number of samples;

δ = a priori difference that should be considered as significant;

p = number of groups;

s_e^2 = error variance;

Φ = parameter, coming from Pearson-Hartely graphs, which is related to the statistical a priori power and to the requested statistically significant level;

The experimental data were analysed with appropriate statistical tests using Matlab 7.0 Statistic Toolbox. A p value equal or less than 0.05 was considered as statistical significant

The tests used are:

1. Lilliefors test for goodness of fit to a normal distribution (Lilliefors H.W., 1967).
2. Two way ANOVA for repeated measurements, in order to compare pre and post exposure, value in the groups characterized by different kind of exposures. The factor of variation are: differences in peak amplitude (i.e. pre exposure period – post exposure) and EMF (exposed groups versus control group). The null hypothesis is that the possible

differences present between the two groups occur by chance. The general linear model used is the factorial model with 2 degree: $y_{ij} = \alpha + \beta + \alpha\beta + \varepsilon_{ij}$, where α and β are the factors, ε is the error term and $\alpha\beta$ is the interaction effect.

3. Linear regression analysis on variation coefficients, with test to stress the differences between the angular coefficients

However, due the absence of absolute certainty (for low number of samples) concerning the conditions required by the parametrical tests, the corresponding non parametric test have been also used in order to validate the obtained results. In particular the Friedman's test (nonparametric two-way ANOVA) was used.

All the statistical tests used in the different analyses are reported, in more detailed way, in the “RESULT” chapter.

CHAPTER 3

RESULTS

Experiments were performed in 5 different experimental conditions:

1 - ELF effects on synaptic transmission:

- Experiments on basal synaptic transmission with 1.0 mT 50 Hz (sinusoidal) magnetic field exposure, for 1 hour;
- Experiments on basal synaptic transmission with 2.3 mT 50 Hz (sinusoidal) magnetic field exposure, for 1 hour;
- Control experiments.

2 - ELF effects on LTP maintenance:

- Experiments on LTP maintenance with 2.3 mT 50 Hz (sinusoidal) magnetic field exposure, for 30 minutes;
- Control experiments.

3 - RF effects on synaptic transmission (1 hour):

- Experiments on basal synaptic transmission with 2 W/kg 900 MHz CW exposure for 1 hour;
- Control experiments.

4 - RF effects on synaptic transmission (5 minutes):

- Experiments on basal synaptic transmission with 2W/kg and 4W/kg CW exposure for 5 minutes;
- Experiments on basal synaptic transmission with 2W/kg and 4W/kg GSM exposure for 5 minutes;
- Control experiments.

5 - RF effects on induction of LTP:

- Experiments of basal synaptic transmission with 2W/kg and 4W/kg GSM exposure for 5 minutes and then LTP induction
- Control experiments.

Previous pilot studies have demonstrated that data obtained with this technique can be considered as normally distributed (Lilliefors test for goodness of fit to a normal distribution (Lilliefors H.W., 1967)). Anyway, if uncertainty on existence of the conditions required by a parametric test is present (as often happens with a little amount of data), a double strategy is in general suggested; first step: using an appropriate test of parametric statistics; second step: validating the results obtained with the correspondent non parametric test.

If probability values obtained with the two tests are similar, the robustness and the validity of the parametric test are confirmed. So, the non parametric test was used to confirm the results obtained with the parametric one and it was considered as a preventive measure against objections concerning the normality and the homoscedasticity of data.

3.1 ELF EFFECTS ON SYNAPTIC TRANSMISSION

The first series of experiments was aimed at testing whether 50 Hz EMFs (1.0 mT or 2.3 mT) can affect basal synaptic transmission perirhinal cortex in horizontal brain slices obtained from rats. After 20 minutes of stable BL recording, each slice was exposed for 60 minutes to the field (1.0 mT, n = 9 figure 30a; 2.3 mT, n = 9, figure 30b). The synaptic response was recorded during EMF exposure and for 30 min after it. Control experiments were performed in no exposure conditions (n = 12, figure 30c).

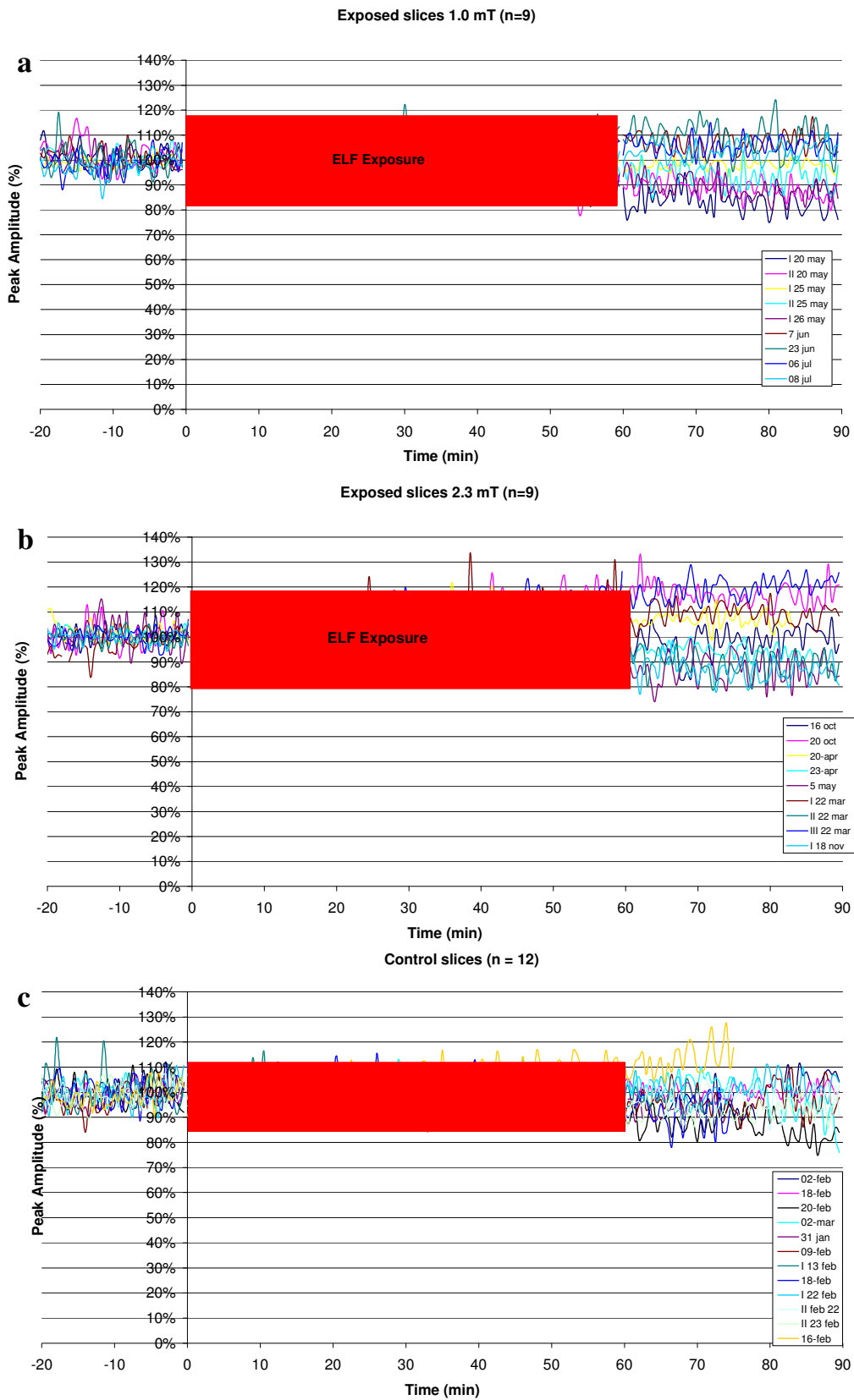

Fig. 30: 1 hour ELF transmission experiments, in red the exposure period (or a corresponding period for CTRL). Fig. 30a: 1.0 mT experiments; Fig. 30b: 2.3 mT experiments; Fig 30c: CTRL experiments.

“A priori” statistical power analysis was performed to evaluate the number of samples requested to detect, at significance level of 0.05 and with a statistical power of at least 0.8, a difference in the peak amplitude between control versus exposed group of 10 % (or more). Using a variance, calculated from a 2 hours pilot study, of about 35, the number of samples required is equal or greater of 7.

The figure below (figure 31) reports the peak amplitude trend for the 3 groups: control group (CTRL), 1.0 mT exposed group (1.0 mT) and 2.3 mT exposed group (2.3 mT). Data are presented as mean \pm standard deviation (S.D.)

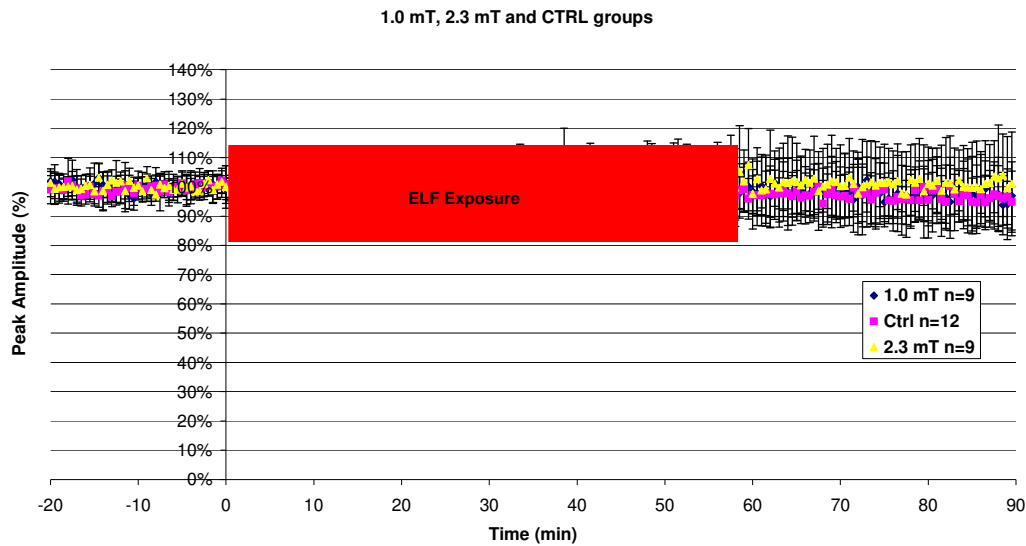

Fig. 31: Peak amplitude trend for the 3 groups. In red the exposure period (or a corresponding period for CTRL). Data are presented as mean \pm S.D..

Differences between pre-exposure period and post-exposure period (the analogous for CTRL slices) were considered. The post-exposure period was divided in 5 minutes intervals. In this way the variability intra-slices can be included in the analysis and, moreover, if small or transient changes occurred immediately after exposure and then disappeared, they could be seen.

More specifically, for each slice, the following differences were considered: average of values from minute 60 to 65 minus average of the values corresponding to the 20 minutes before exposure (1 difference); average of values from minute 65 to 70 minus average of

the values corresponding to the 20 minutes before exposure (II difference); average of values from minute 70 to 75 minus average of the values corresponding to the 20 minutes before exposure (III difference); average of values from minute 75 to 80 minus average of the values corresponding to the 20 minutes before exposure (VI difference). A two way ANOVA for repeated measurements was performed on these differences.

The factors of variation for the ANOVA were: 3 kinds of exposures (CTRL, 1.0 mT and 2.3 mT) and variations between the 4 differences. No statistical significance variations were found neither between the exposures conditions ($p=0.47$) or between the differences ($p=0.99$) (figure 32). The results were also confirmed with the Friedman's test (the so-called non parametric two way ANOVA).

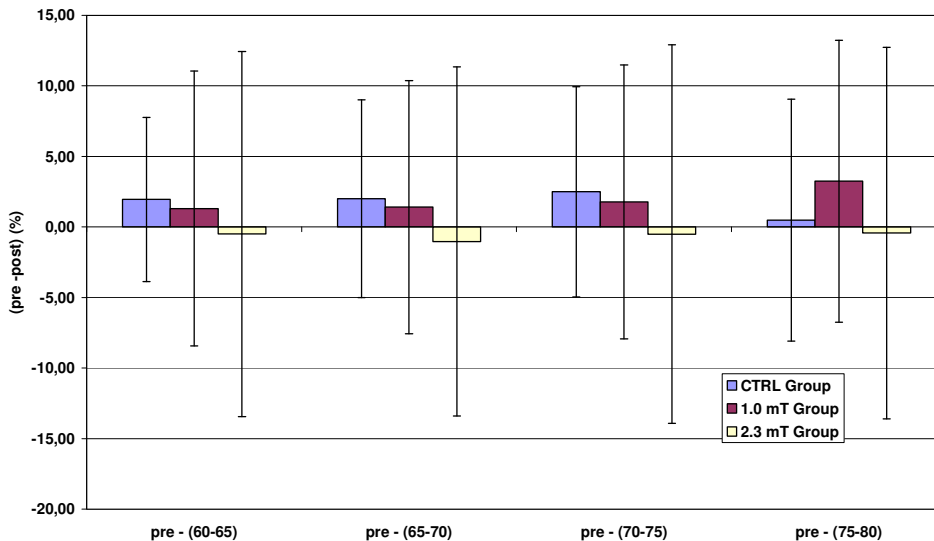

Fig. 32: Differences in the 3 groups. Data are presented as mean \pm S.D..

Looking at the figure an increase in the standard deviation in exposed group can be noted. Plotting, for the 3 groups, the mean values of the peak amplitudes with their S.D., it can be qualitatively seen that the S.D., after ELF exposure, increases. The increase is notable in 1.0 mT group and much more in 2.3 mT group (figure 33)

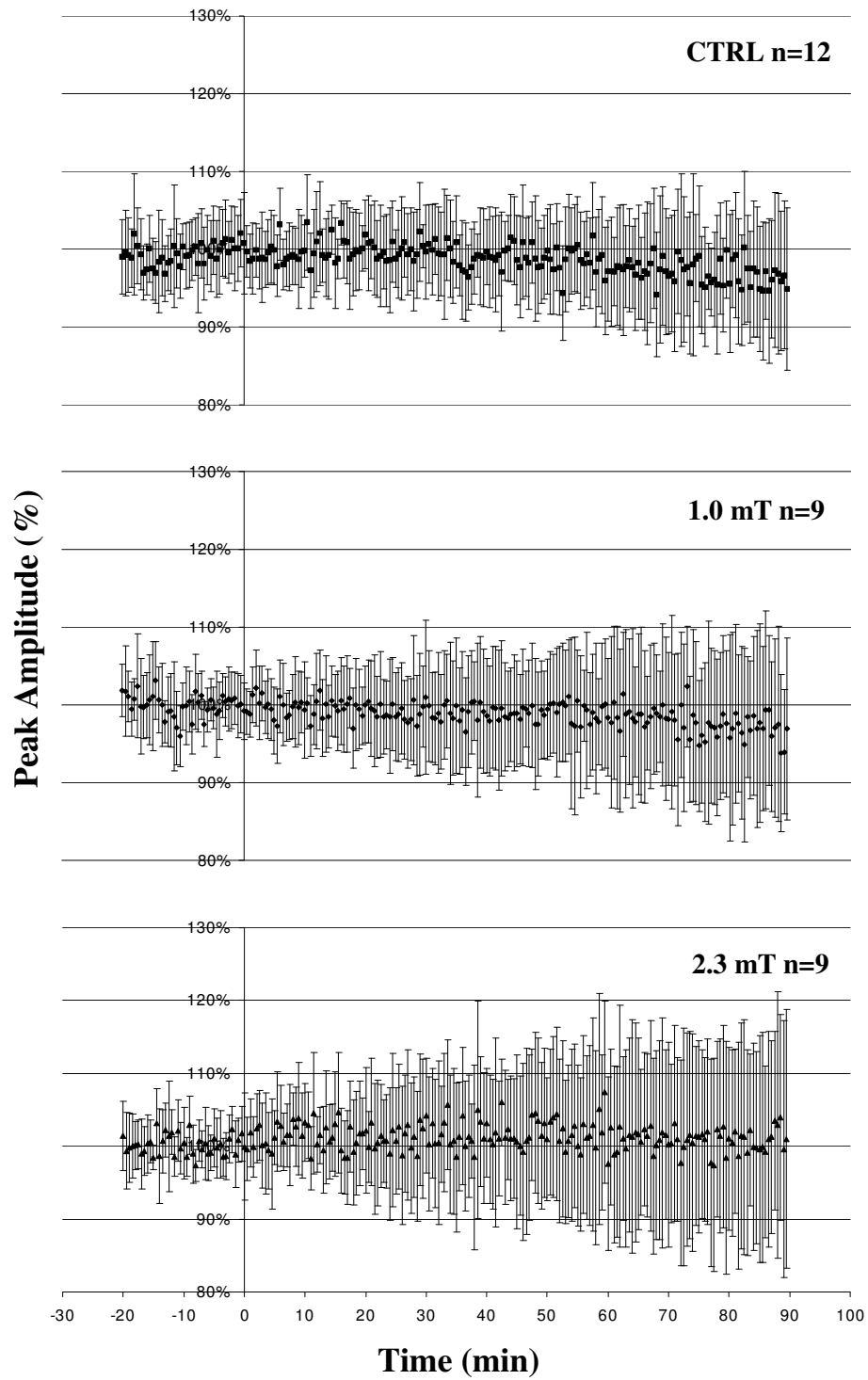

Fig. 33: Peak amplitude values with S.D. for the 3 groups.

In order to understand if this increase in slices response variability is due to the ELF EMF exposure, the variation coefficients (defined as σ/\bar{x} , where σ is the S.D. and \bar{x} is the average value for each time point) were calculated and a linear regression were performed on these values (figure 34). Moreover, after calculating the angular coefficients for each line ($b_{CTRL} = 0.0519$ ($R^2=0.53$); $b_{1.0mT} = 0.0846$ ($R^2=0.71$); $b_{2.3mT} = 0.1167$ ($R^2=0.77$)), a statistic test was performed.

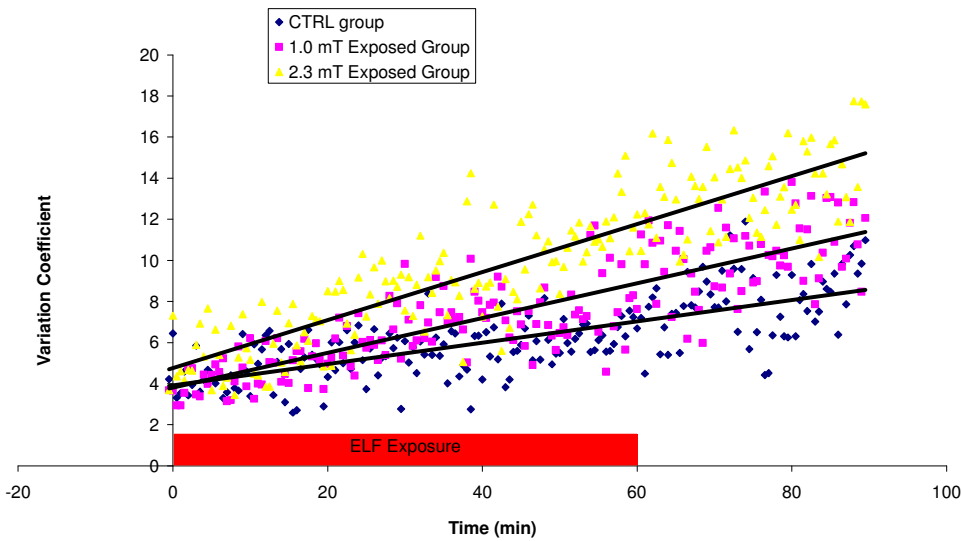

Fig. 34: Variation coefficients for the 3 groups with regression lines. In red the exposure period (or a corresponding period for CTRL).

A statistical significant difference ($p < 0.01$) was found between the angular coefficients (using a test that compares different regression lines each other with the F test). A post hoc test, the Dunn-Sidak test (Ury H.K., 1976), has revealed that both angular coefficients of the variation coefficient regression line of 1.0 mT group and of 2.3 mT group were different each other and also from that of the CTRL group (figure 35)

In conclusion, it seems to exist a dose–response curve focused on the variability of the slice response more than on the response itself.

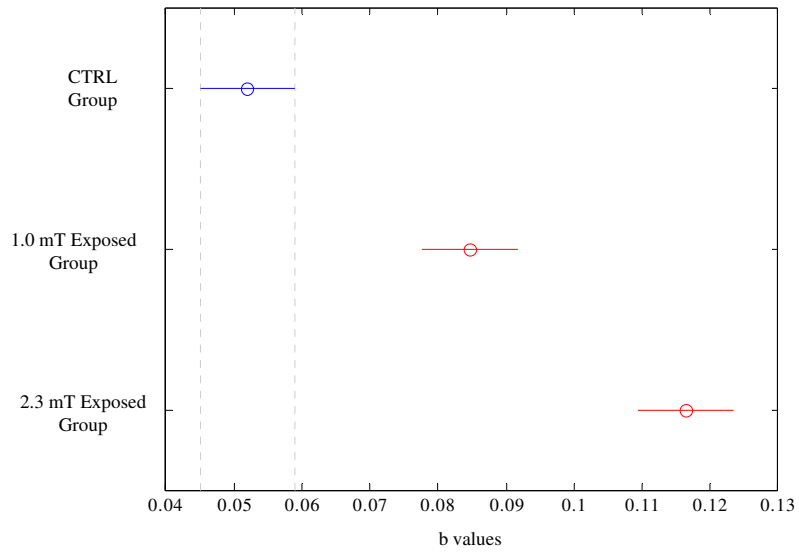

Fig. 35: angular coefficients of the variation coefficient regression line of 1.0 mT group, 2.3 mT group and CTRL group.

3.2 ELF EFFECTS ON LTP MAINTENANCE

In the experiments in which slices were exposed to a sinusoidal 50 Hz magnetic field during LTP the field intensity was 2.3 mT (n = 5, figure 36a); the exposure started 40 min after the TBS used to induce LTP (considered as an increase of more than 10 % in peak amplitude and stable for at least 25 min after the stimulation), and lasted 30 min. Control experiments consisted in LTP elicited and maintained in no exposure conditions (n = 4, figure 36b).

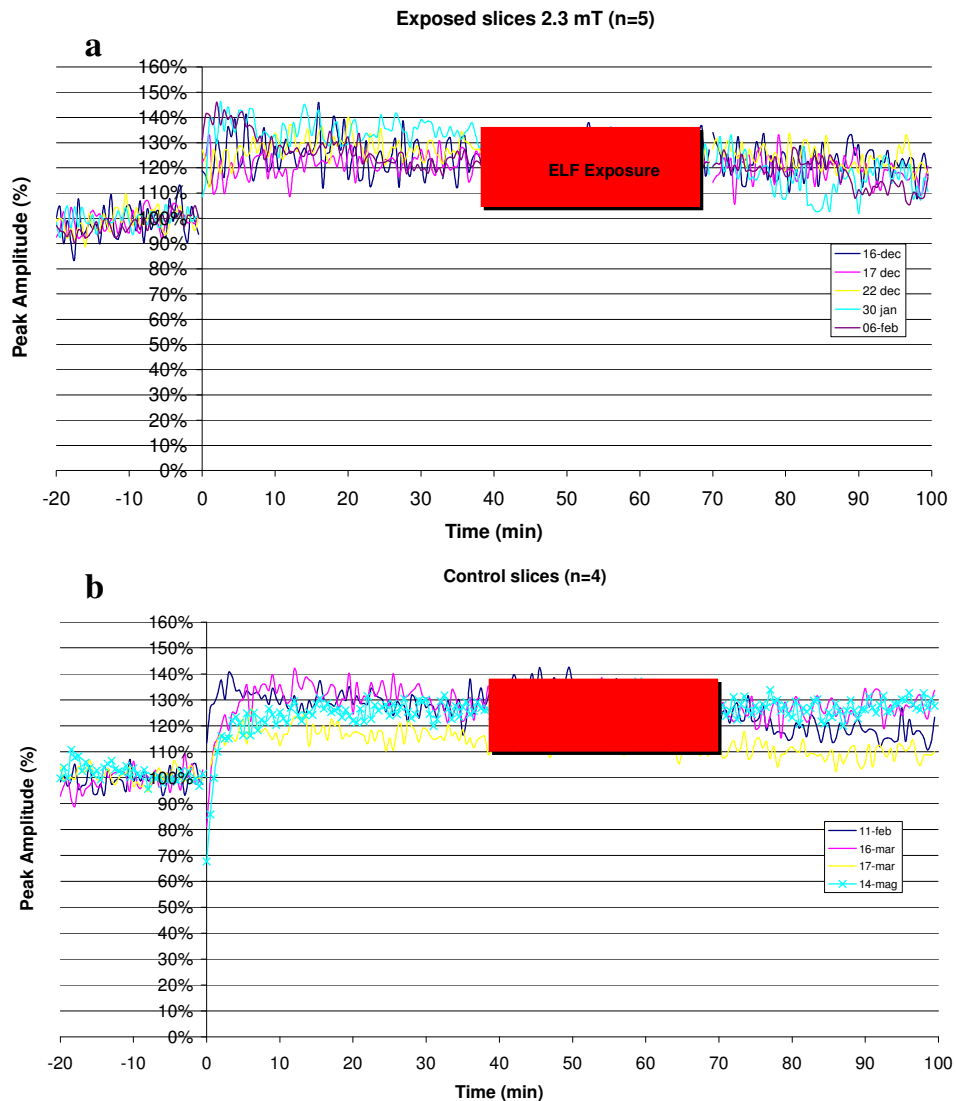

Fig. 36: 30 minutes ELF LTP experiments, in red the exposure period (or a corresponding period for CTRL). Fig. 36a: 2.3 mT experiments; Fig 36b: CTRL experiments.

“A priori” statistical power analysis was performed to evaluate the number of samples requested to point out, at significance level of 0.05 and with a statistical power of at least 0.8, a difference in the peak amplitude between control versus exposed group during the LTP of 20 % (or more). Using a variance of about 60 the number of samples required is at least 4.

Primarily, a control was done to check the amplitude of the potentiation. The average of the values corresponding to 20 minutes of the BL in exposed group, 20 minutes of BL in CTRL, 20 minutes after TBS (starting after 3 minutes from the TBS, when the potentiation has stabilized itself) in exposed group and 20 minutes after TBS in CTRL were compared using a two way ANOVA for repeated measurements (confirmed with the Friedman's test). The only difference found (as expected) was between the conditions “before” versus “after” TBS (figure 37).

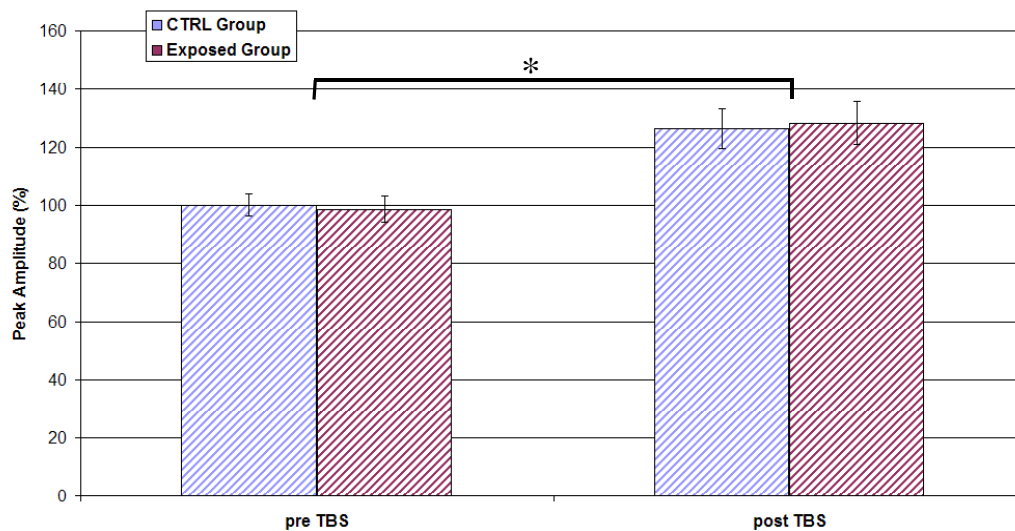

Fig. 37: Peak amplitude for the 2 groups before and after TBS.

The figure 38 reports the peak amplitude trend for the 2 groups: control group (CTRL) and 2.3 mT exposed group (2.3 mT). Data are presented as mean \pm S.D.

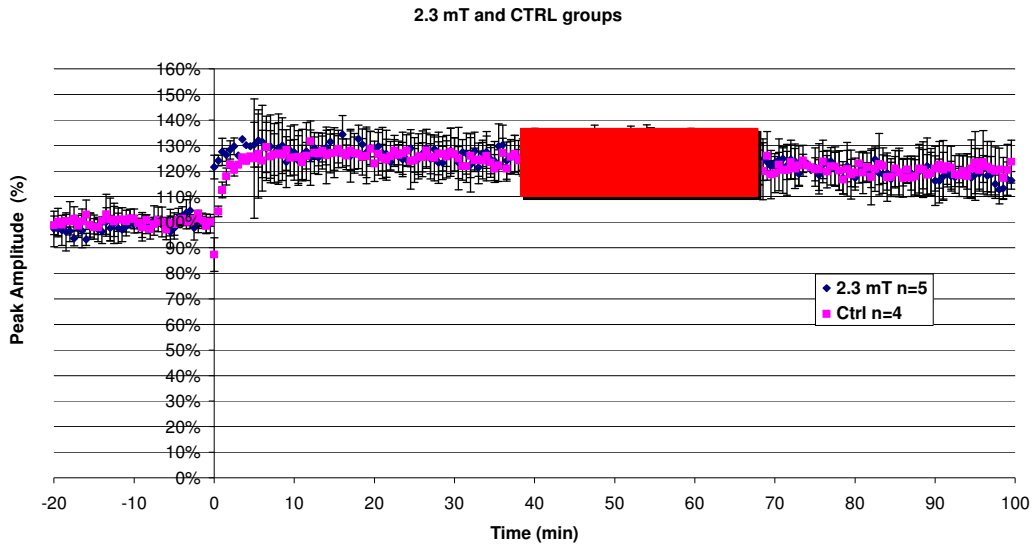

Fig. 38: Peak amplitude trend for the 2 groups. In red the exposure period (or a corresponding period for CTRL). Data are presented as mean \pm S.D..

Differences between pre-exposure period and post-exposure period (the analogous for CTRL slices) were considered. The post-exposure period was divided in 5 minutes intervals.

More specifically, for each slice, the following differences were considered: average of values from minute 70 to 75 minus average of the values from minute 20 to 40, i.e. 20 minutes before exposure (I difference); average of values from minute 75 to 80 minus average of values from minute 20 to 40 (II difference); average of values from minute 80 to 85 minus average of the values from minute 20 to 40 (III difference); average of values from minute 85 to 90 minus average of the values from minute 20 to 40 (VI difference); A two way ANOVA for repeated measurements was performed on these differences.

The factors of variation for the ANOVA were: 2 kinds of exposures (CTRL and 2.3 mT exposure) and variations between the 4 differences. No statistical significance variations were found neither between the exposures conditions ($p=0.86$) or between the differences ($p=0.94$) (figure 39).

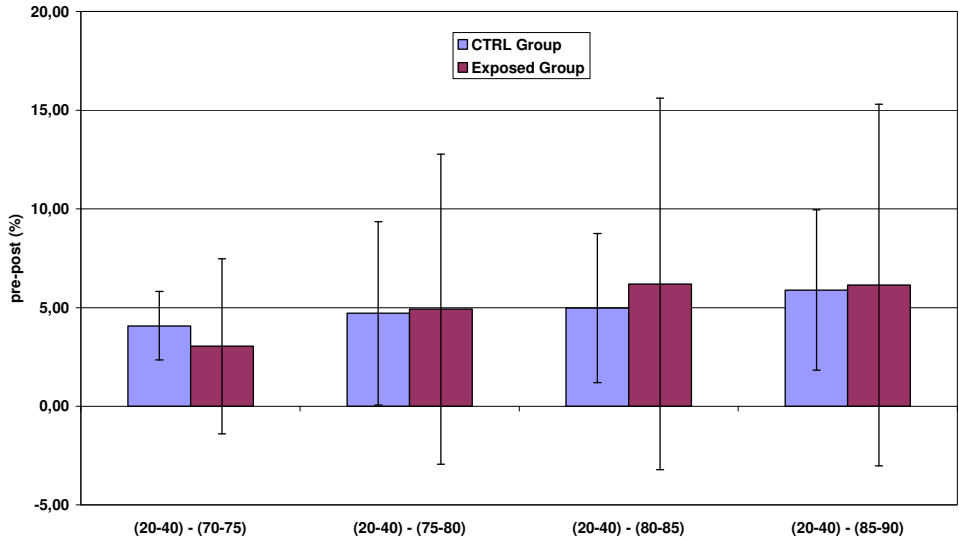

Fig. 39: Differences in the 2 groups. Data are presented as mean \pm S.D..

The results were also confirmed with the Friedman's test. Here again there was an increase of the S.D. in post-exposed value. However, after the calculation of the variation coefficient and of their regression lines (figure 40), due to the very low value of Pearson's coefficient of regression ($R^2_{CTRL} = 0.0075$, $R^2_{EXPO} = 0.1214$), it was not possible to draw any statistical conclusion about the difference variability in data responses.

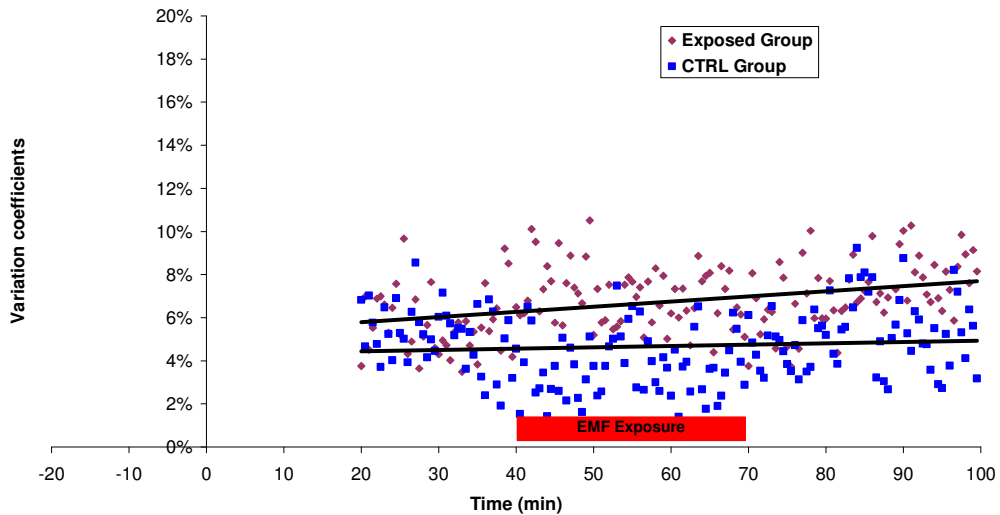

Fig. 40: Variation coefficients for the 2 groups with regression lines. in red the exposure period (or a corresponding period for CTRL).

3.3 RF EFFECTS ON SYNAPTIC TRANSMISSION (1 HOUR EXPERIMENTS)

This series of experiments was aimed at testing whether 900 MHz EMFs (CW 2 W/kg) can affect basal synaptic transmission the perirhinal cortex in horizontal rat brain slices. After 20 min of stable BL recording, each slice was exposed for 60 min to the field (n = 8). The synaptic response was recorded during EMF exposure and for 30 min after it. Control experiments were performed in no exposure conditions (n = 7); see fig. 41a and 42b.

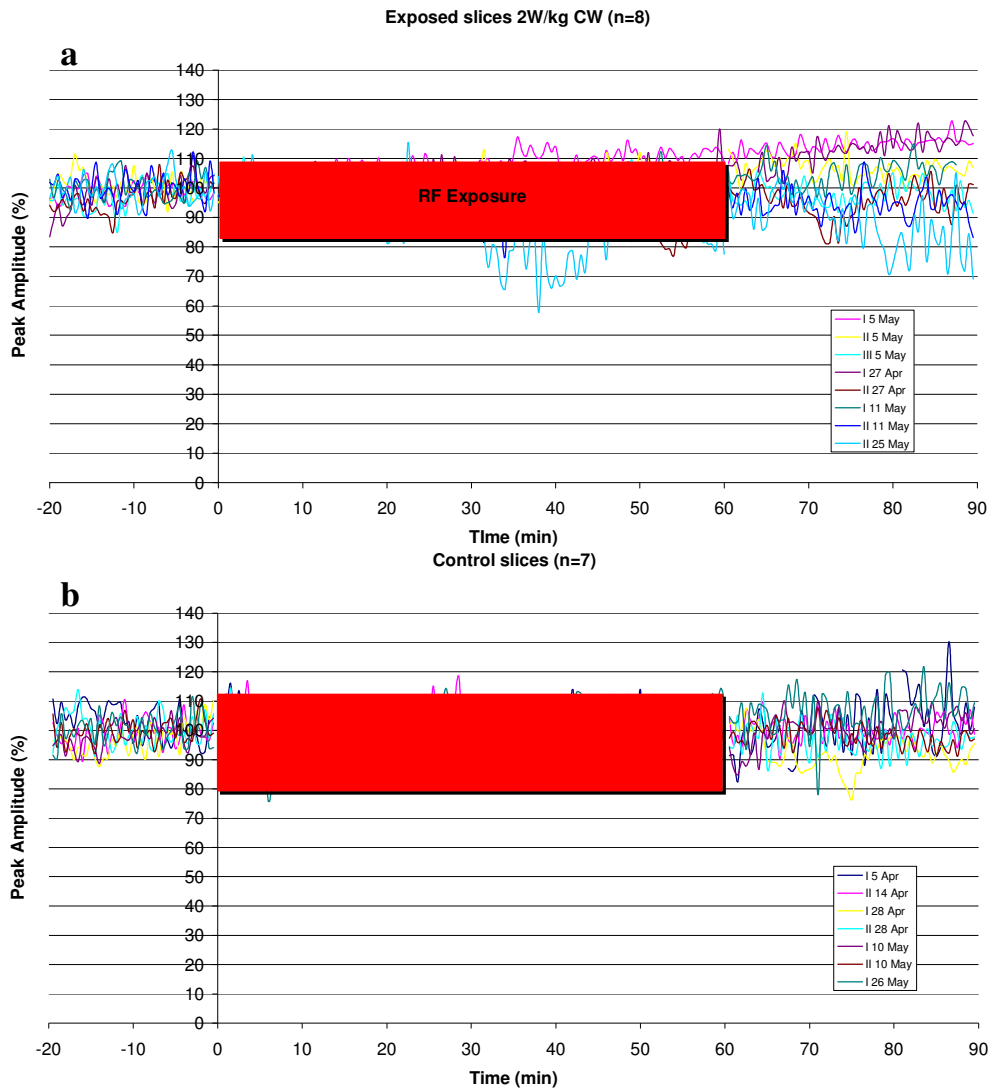

Fig. 42: 1 hour CW experiments, in red the exposure period (or a corresponding period for CTRL). Fig. 42a: CTRL experiments; Fig. 42b: 2W/kg CW experiments.

“A priori” statistical power analysis was performed to evaluate the number of samples requested to highlight, at significance level of 0.05 and with a statistical power of at least 0.8, a difference in the peak amplitude between control versus exposed group of 10 % (or more). Using a variance, calculated from a 2 hours pilot study, of about 35, the number of samples required is equal or greater of 7.

The figure below (figure 43) reports the peak amplitude trend for the 2 groups: control group (CTRL) and 2 W/kg 900 MHz CW exposed group (2 W/kg CW). Data are presented as mean \pm S.D.

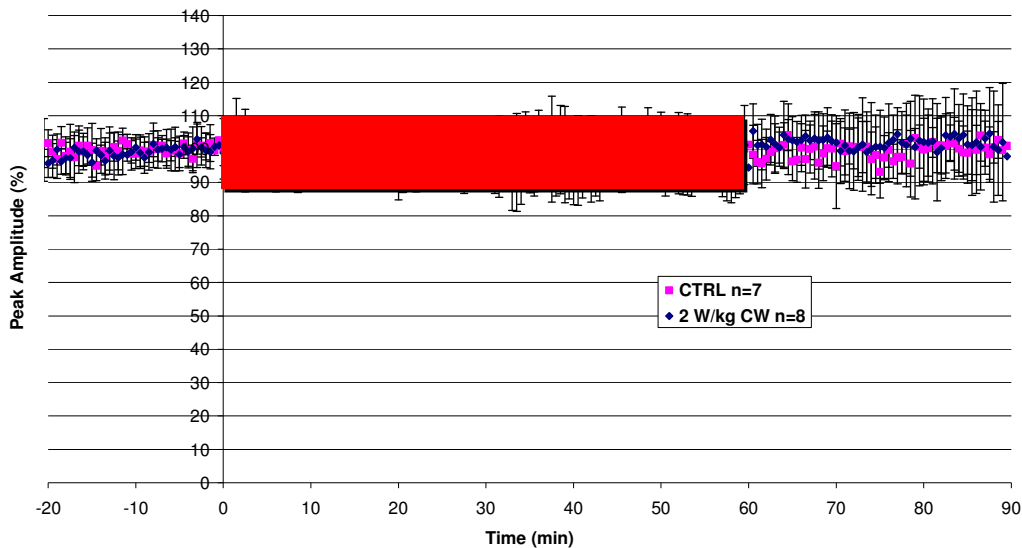

Fig. 43: Peak amplitude trend for the 2 groups. In red the exposure period (or a corresponding period for CTRL). Data are presented as mean \pm S.D..

Differences between pre-exposure period and post-exposure period (the analogous for CTRL slices) were considered. The post-exposure period was divided in 5 minutes intervals.

More specifically, for each slice, the following differences were considered: average of values from minute 60 to 65 minus the average of the values corresponding to the 20 minutes before exposure (I difference); average of values from minute 65 to 70 minus the average of the values corresponding to the 20 minutes before exposure (II difference); average of values from minute 70 to 75 minus the average of the values corresponding to the 20 minutes before exposure (III difference); average of values from minute 75 to 80 minus the average

of the values corresponding to the 20 minutes before exposure (VI difference). A two way ANOVA for repeated measurements was performed on these differences.

The factors of variation for the ANOVA were: 2 kinds of exposures (CTRL, 2 W/kg exposure) and variations between the 4 differences.

No statistically significant variations were found between the differences ($p=0.99$), indicating that no variations occurred in peak amplitude during the 20 minutes considered after the exposure. A statistically significant decrease in peak amplitudes variation in 2 W/kg exposed slices was seen compared to those of CTRL group ($p=0.04$). See figure 44.

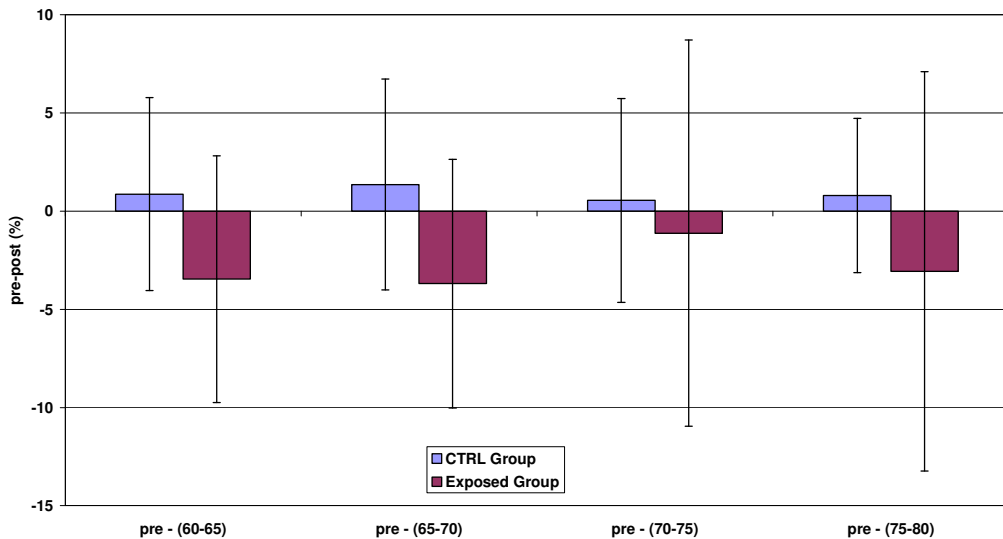

Fig. 44: Differences in the 2 groups. Data are presented as mean \pm S.D..

Results were also confirmed with the Friedman’s test.

However the differences between peak amplitudes are very small (3 %) and well below the 10 % defined in the “a priori” power analysis (figure 45).

Again, looking at the figure an increase in the S.D. in the exposed group can be noted.

Plotting the mean values of the peak amplitudes with their S.D. (figure 46), it can be qualitatively seen that the S.D., after RF exposure, show a little increase.

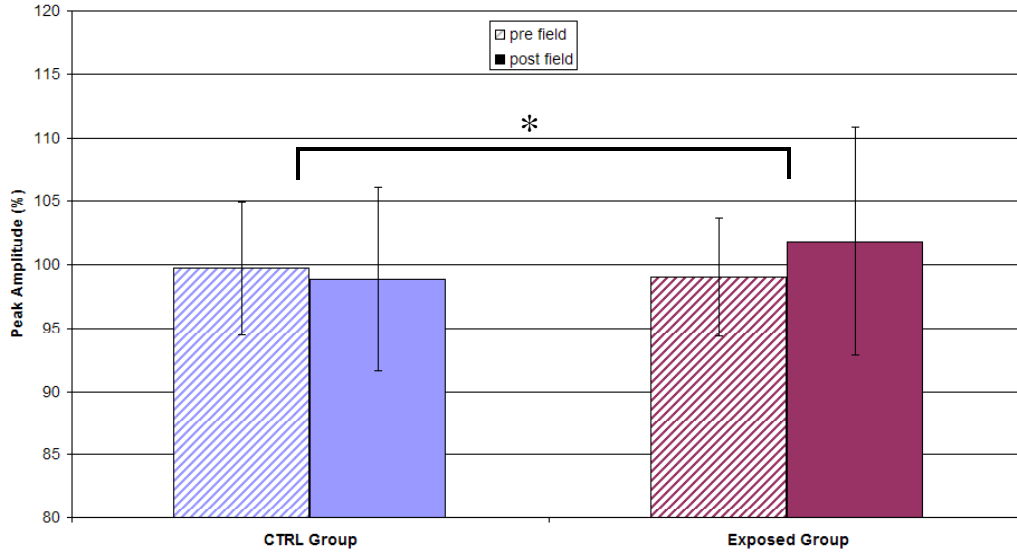

Fig. 45: Peak amplitude for the 2 groups before and after exposure.

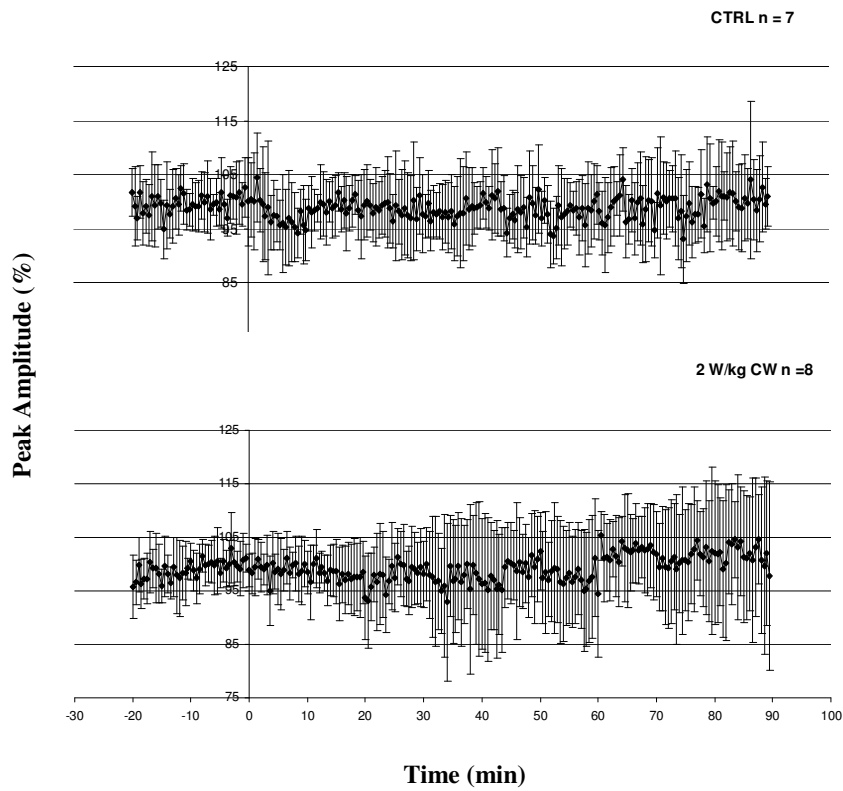

Fig. 46: Peak value with S.D. for the 2 groups.

The variation coefficients were calculated, and a linear regression was performed on these values: $b_{CTRL} = 0.008$ ($R^2=0.01$); $b_{Exposed} = 0.069$ ($R^2=0.29$) (figure 47);

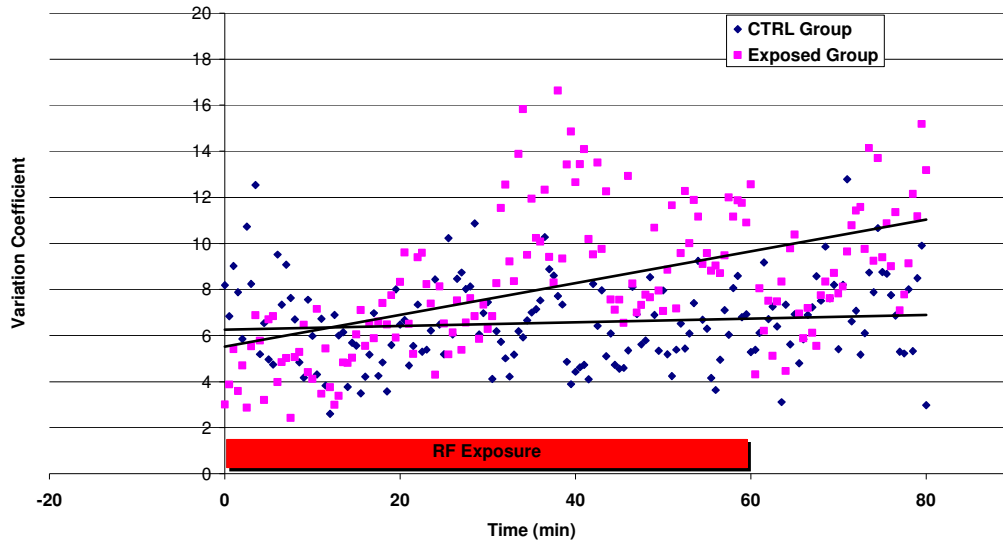
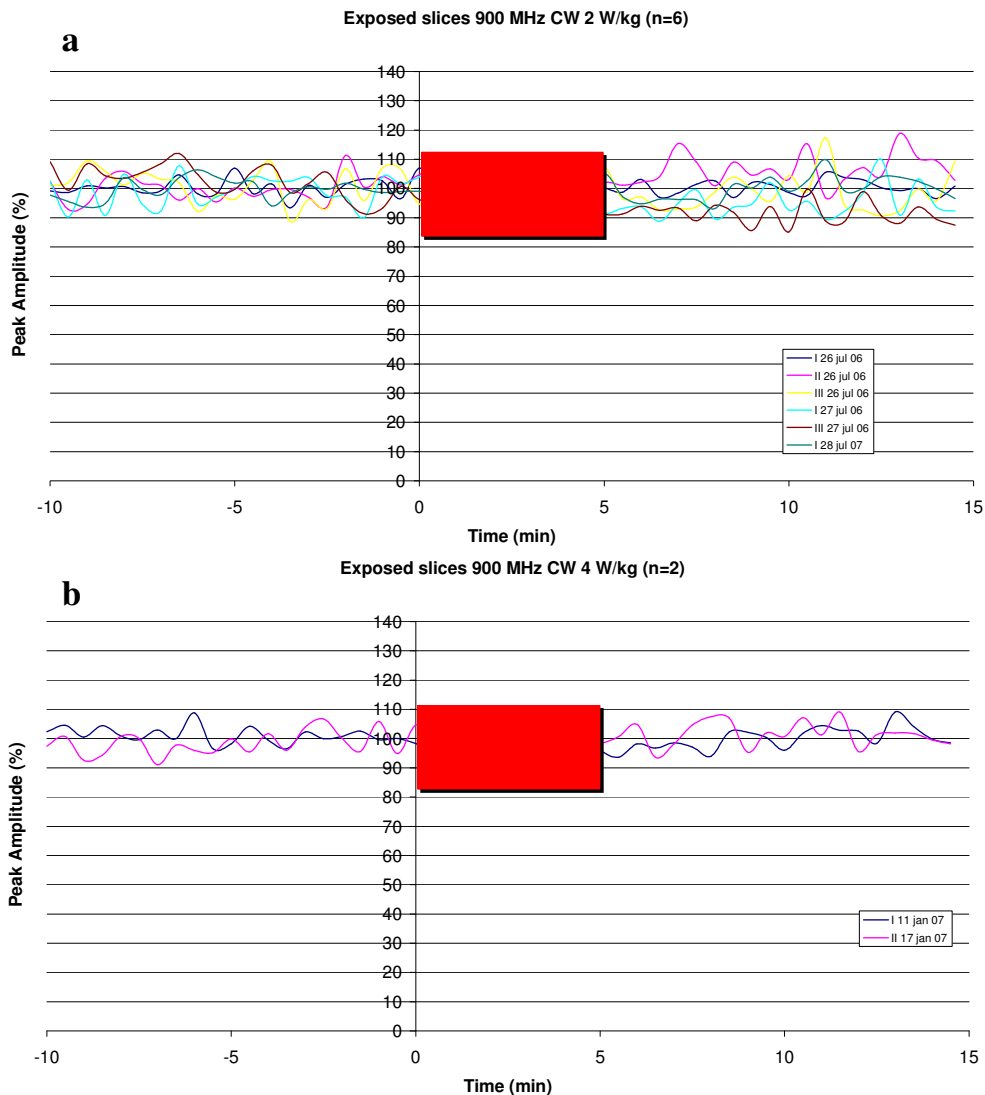

Fig. 47: Variation coefficients for the 2 groups with regression lines. In red the exposure period (or a corresponding period for CTRL).

However, due to the very low value of Pearson's coefficient of regression, any statistical analysis aimed to stress a difference in the angular coefficients is meaningless.

3.4 RF EFFECTS ON SYNAPTIC TRANSMISSION (5 MINUTE EXPERIMENTS)

This series of experiments was aimed at testing whether 900 MHz EMFs (different signals: CW 2 W/kg; CW 4 W/kg; GSM 2W/kg; GSM 4W/kg) can affect basal synaptic transmission in perirhinal cortex in rat horizontal brain slices. After 20 min of stable BL recording, each slice was exposed for 5 min to the field. In figure 48a slices exposed to CW 2 W/kg (n=8); in figure 48b to CW 4 W/kg (n=2); in figure 48c GSM 2W/kg (n=14); in figure 48d GSM 4W/kg (n=8). The synaptic response was recorded during EMF exposure and for 10 minutes after it. Control experiments were performed in no exposure conditions (n = 15, figure 48e)



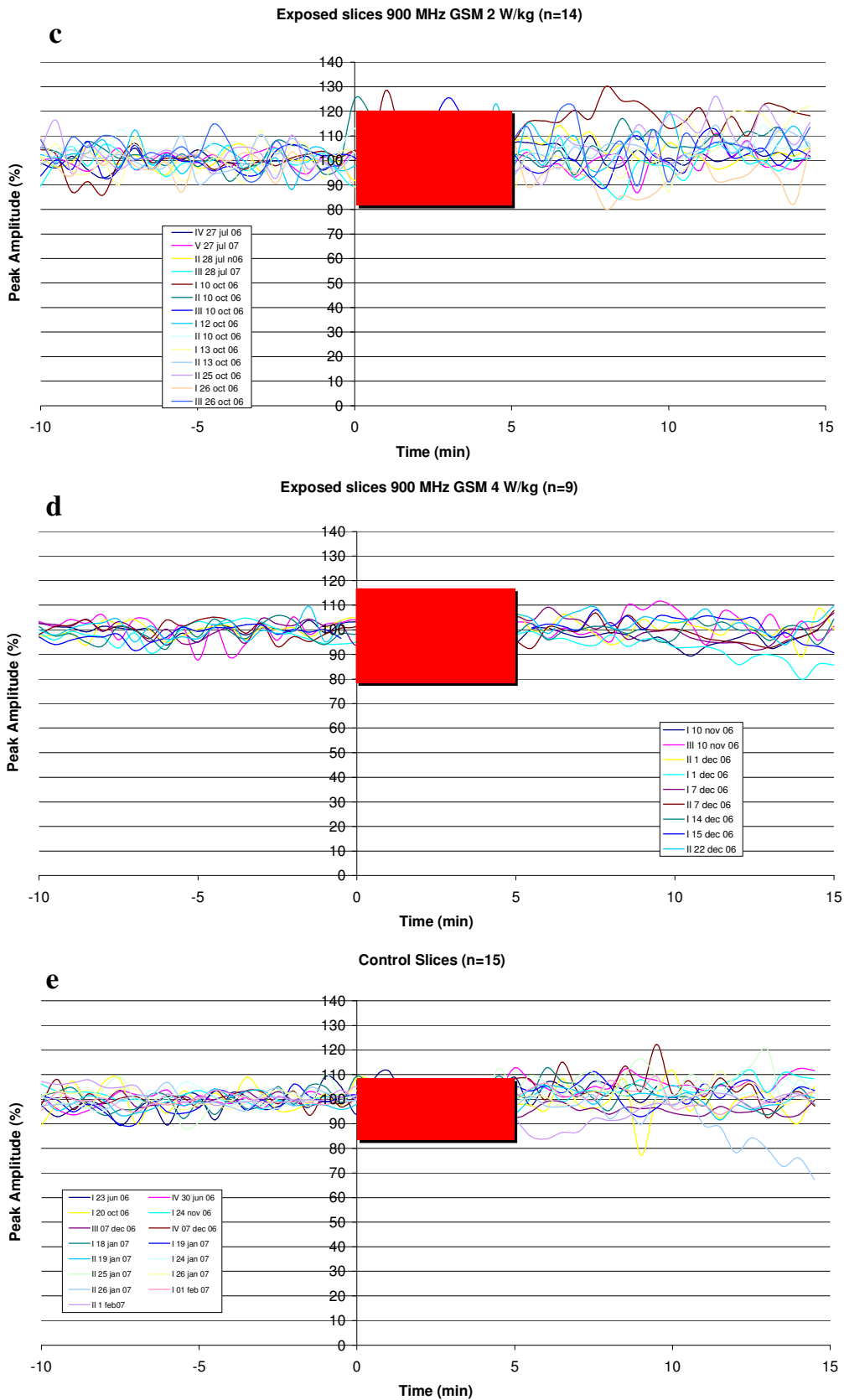

Fig. 48: 5 minutes RF transmission experiments, in red the exposure period (or a corresponding period for CTRL). Fig. 48a: 2W/kg CW; Fig. 48b: 4W/kg CW; Fig. 48c: 2W/kg GSM; Fig. 48d: 4W/kg GSM; Fig. 48e: CTRL experiments.

“A priori” statistical power analysis was performed to evaluate the number of samples required to stress, at significance level of 0.05 and with a statistical power of at least 0.8, a difference in the peak amplitude between control versus exposed group of 10 %. Using a variance, calculated from a 25 minutes pilot study, of about 30, the number of samples required is equal or greater of 6.

For 2 W/kg GSM experiments, due to importance of this signal (mobile phone communication) and of this SAR value (which is the “localized SAR for head and trunk”, averaged on 10 g, provided in the “Basic Restriction” by the Council of European Union, 1999/519/EC) in all-day life, the statistical power required was increased from 0.8 to 0.95, so the number of samples required is to 14 or greater.

In figure 49 peak amplitude trend for control group (CTRL), 2 W/kg CW exposed group (2W/kg CW) and 4 W/kg CW exposed group (4 W/kg CW) is reported. In figure 50 the peak amplitude trend for control group (CTRL), 2 W/kg GSM exposed group (2W/kg GSM) and 4 W/kg GSM exposed group (4 W/kg GSM) is reported. Data are presented as mean \pm S.D.

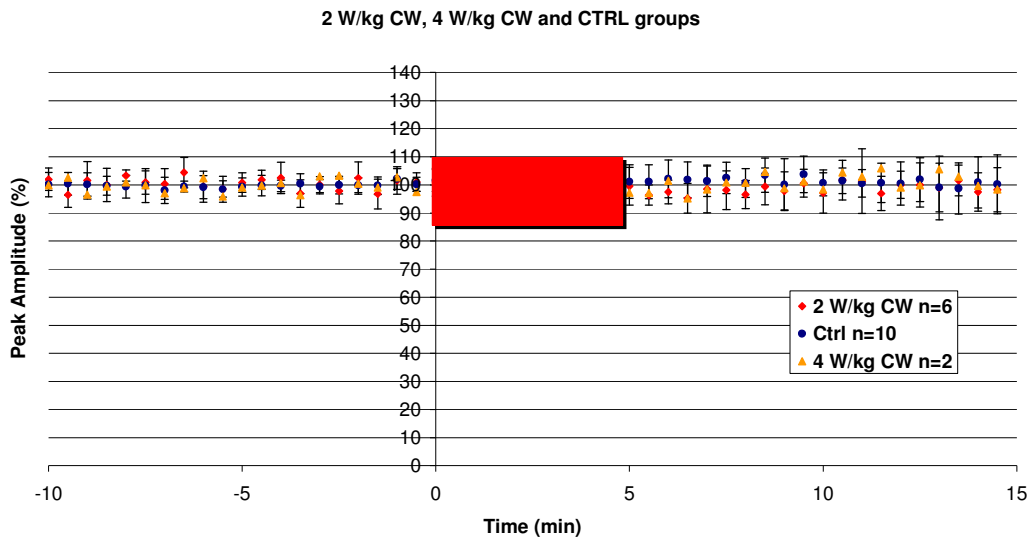

Fig. 49: Peak amplitude trend for the 3 groups (2 W/kg CW; 4 W/kg CW and CTRL). In red the exposure period (or a corresponding period for CTRL). Data are presented as mean \pm S.D..

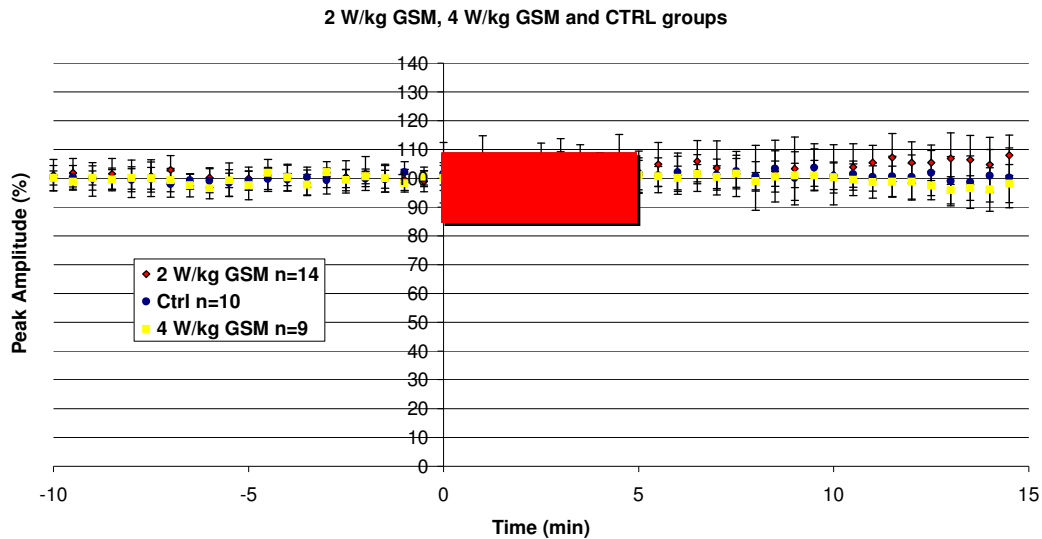

Fig. 50: Peak amplitude trend for the 3 groups (2 W/kg GSM; 4 W/kg GSM and CTRL). In red the exposure period (or a corresponding period for CTRL). Data are presented as mean \pm S.D..

Differences between pre-exposure period and post-exposure period (the analogous for CTRL slices) were considered. The post-exposure period was divided in 5 minutes intervals.

More specifically, for each slice, the following differences were considered: average of values from minute 5 to 10 minus the average of the values corresponding to the 10 minutes before exposure (I difference); average of values from minute 10 to 15 minus the average of the values corresponding to the 10 minutes before exposure (II difference); a two way ANOVA for repeated measurements was performed on these differences.

3.4.1 GSM 2 W/kg and 4 W/kg

The factors of variation for the ANOVA were: 3 kinds of exposures (CTRL, 2W /kg GSM and 4 W/kg GSM) and the variations between the 2 differences (figure 51).

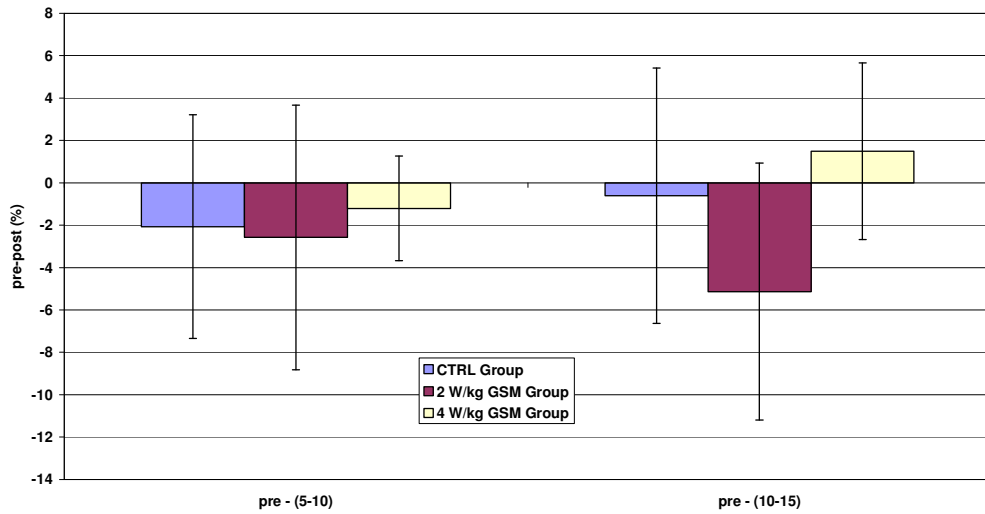

Fig. 51: Differences in the 2 groups. Data are presented as mean \pm S.D.

No statistically significant variations were found between the differences ($p=0.68$), indicating that no variations occurred in peak amplitude during the 10 minutes considered after the exposure. A statistically significant difference was found in peak amplitude variation depending on the exposure conditions. A post hoc test (Dunn Sidak) has showed that a statistically significant difference was present between the variation in the 2 W/kg GSM group versus 4 W/kg GSM group. See figure 52 and 53. Resulted were also confirmed with Freidman's test.

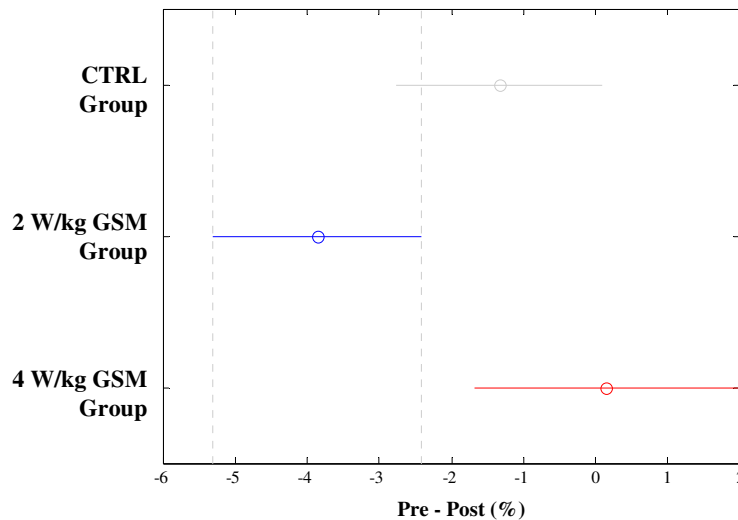

Fig. 52: average value of the differences in CTRL group, 2 W/kg GSM group and 4 W/kg GSM group.

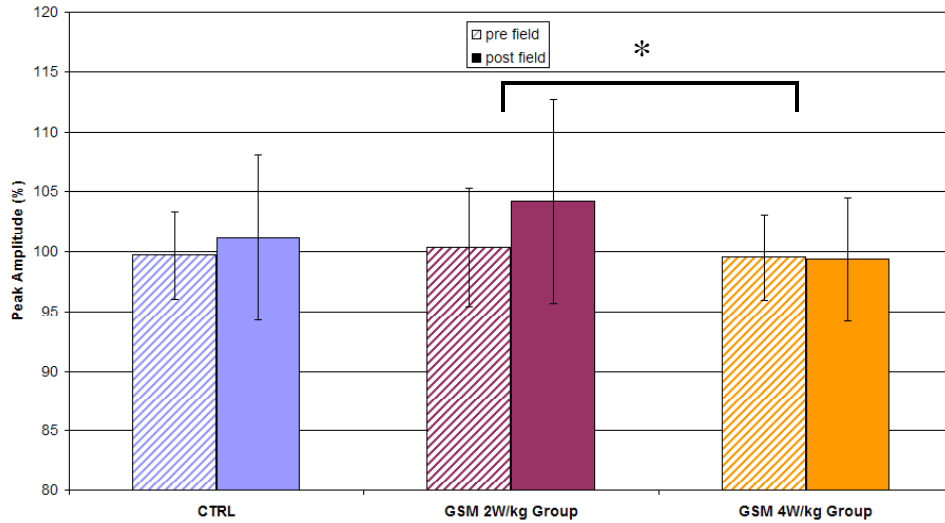

Fig. 53: Peak amplitude in the 3 groups (CTRL; 2 W/kg GSM and 4 W/kg GSM) before and after the exposure. Data are presented as mean \pm S.D. Statistically significant difference is indicated with asterisk.

3.4.2 CW 2 W/kg

The factors of variation for the ANOVA were: 2 kinds of exposures (CTRL, 2W /kg CW) and the variations between the 2 differences. No statistical significance variations were found neither between the differences ($p=0.98$) or kinds of exposure ($p=0.12$) (figure 54).

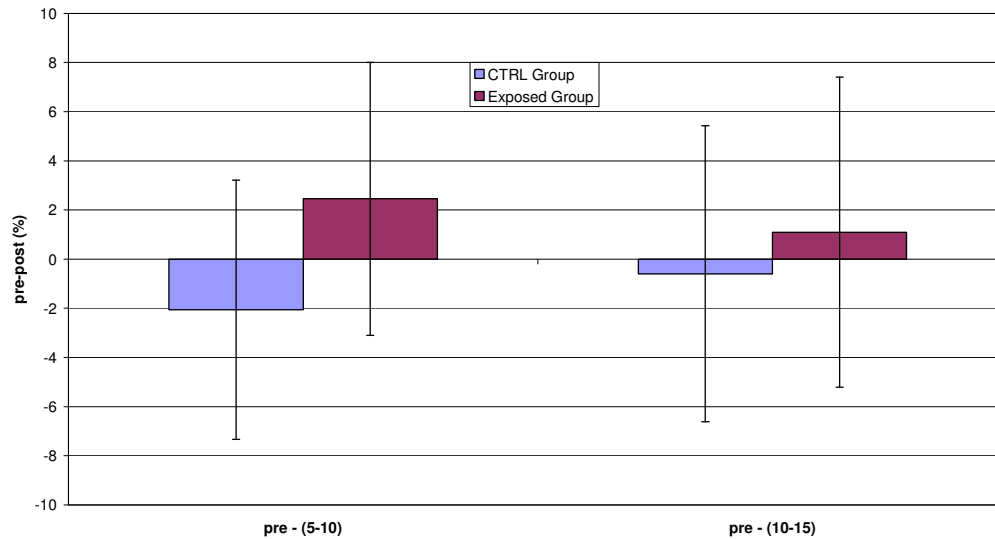

Fig. 54: Differences in the 2 groups. Data are presented as mean \pm S.D

3.4.3 CW 4 W/kg

Until now only 2 experiments were performed with this SAR value and the plots (figure 55) have only a qualitative meaning.

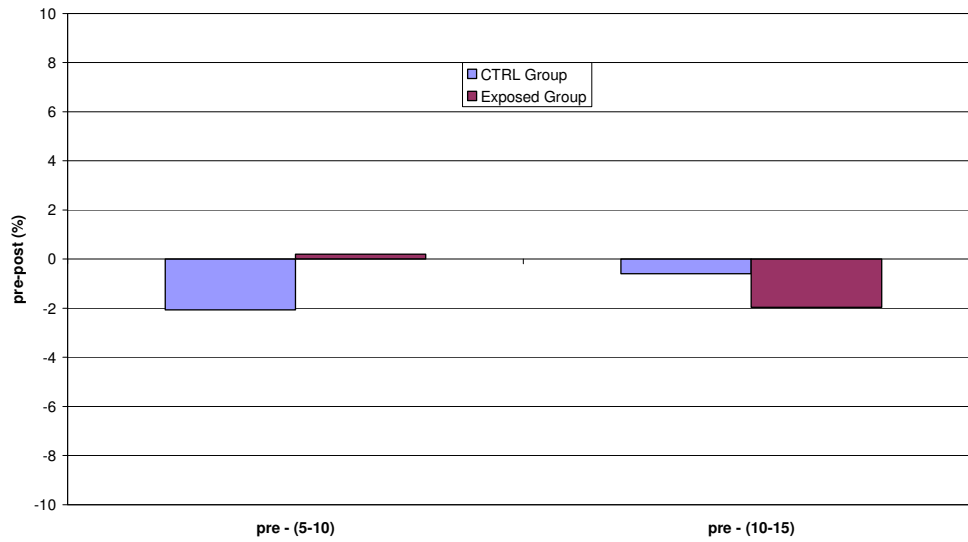

Fig. 54: Differences in the 2 groups

For this exposure condition experiments are in progress

Figure 55 reports plots of the mean values of the peak amplitudes with their S.D.. No increase in S.D. after exposure (of any types) has been noted.

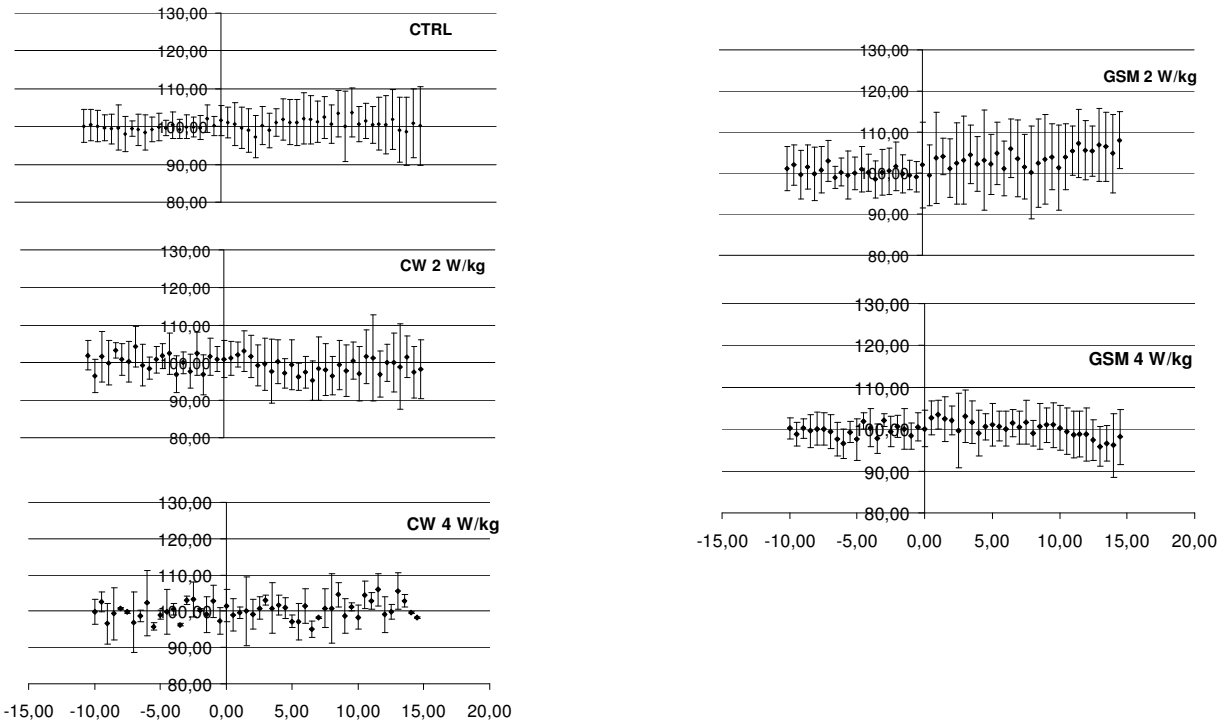
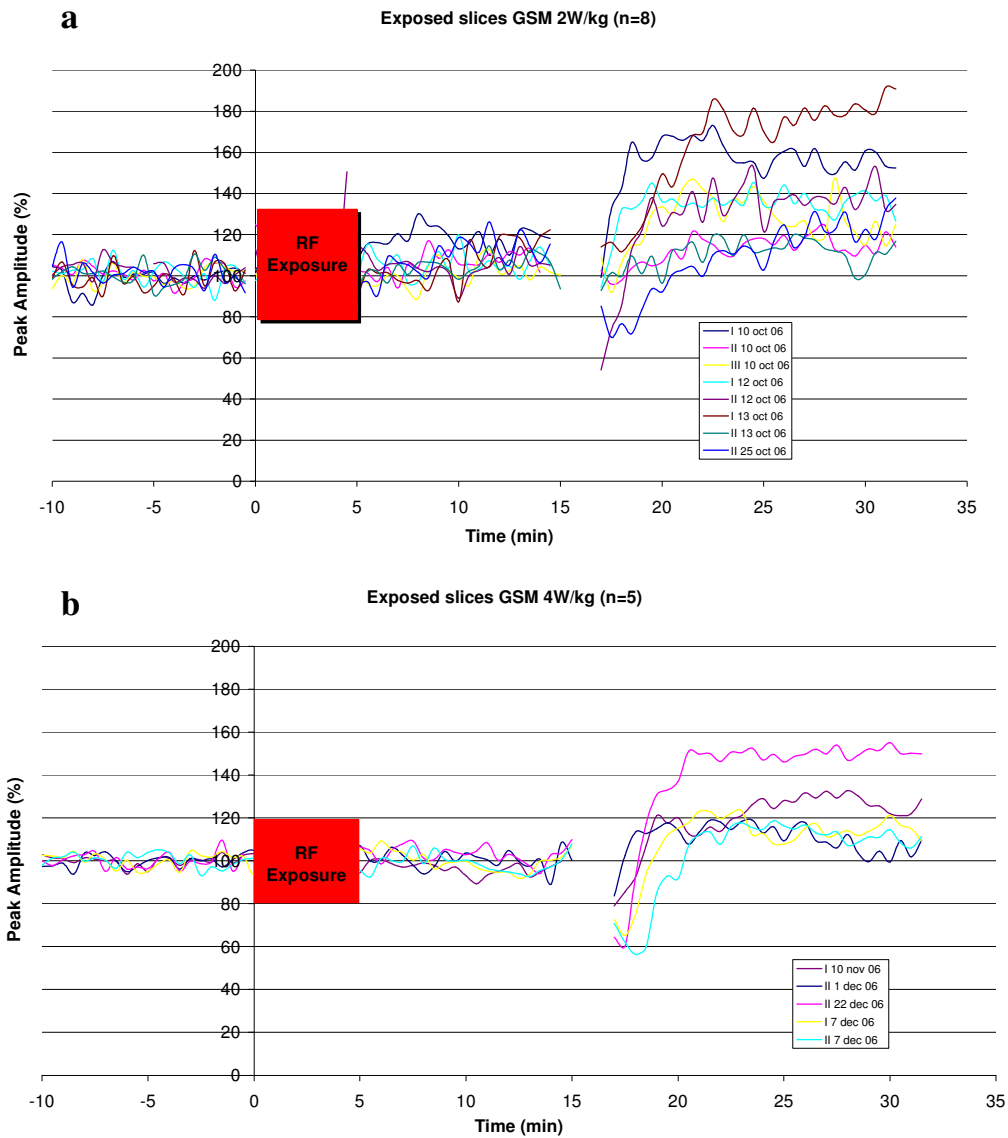

Fig. 55: Peak value with S.D. for the 5 groups.

3.5 RF EFFECTS ON THE INDUCTION OF LTP (5 MINUTE EXPERIMENTS)

This series of experiments was aimed at testing whether 900 MHz GSM EMFs at two different SAR (2W/kg; 4W/kg) can affect the amplitude of the potentiation induced after TBS (considered as an increase of more than 10% in peak amplitude and stable for at least 10 minutes after the stimulation). Control experiments consisted in LTP elicited and maintained in no exposure conditions (n = 7) (figure 56).



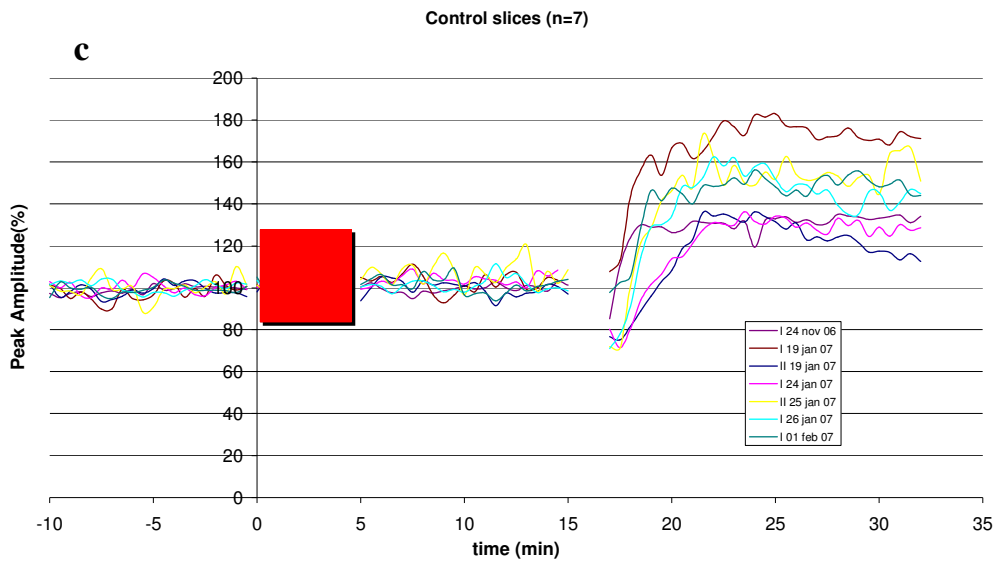

Fig. 56: 5 minutes RF LTP experiments, in red the exposure period (or a corresponding period for CTRL). Fig. 56a: 2W/kg GSM; Fig. 56b: 4W/kg GSM; Fig. 56c: CTRL experiments.

“A priori” statistical power analysis was performed (at significance level of 0.05, statistical power of at least 0.8, a difference in the peak amplitude of the LTP between control versus exposed group $\geq 25\%$). Assuming a variance of about 400 the number of samples required is at least 10. The variance value is much more higher in these experiments due to the great variability in the amplitude of the LTP after TBS in the different slices. The figure below (figure 57) reports

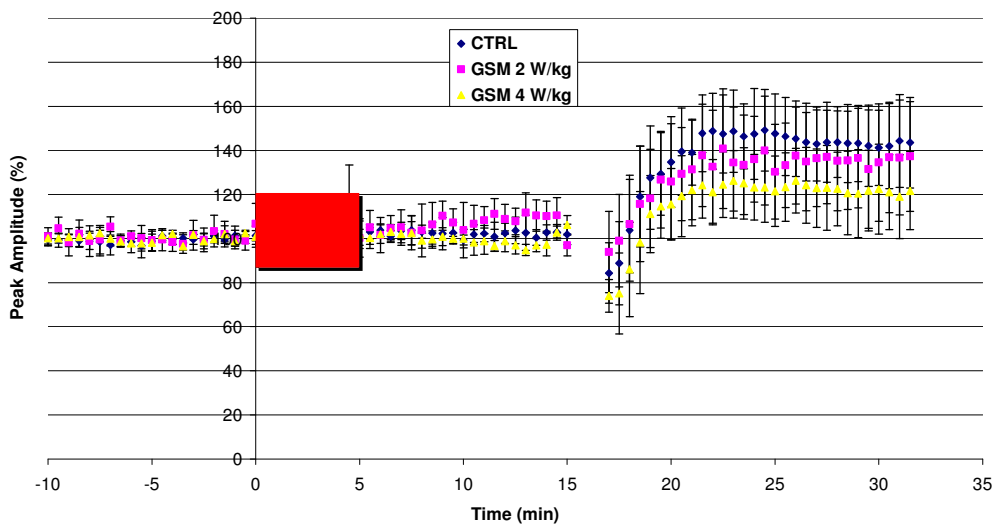

Fig 57: Peak amplitude trend for the 3 groups (2 W/kg GSM; 4 W/kg GSM and CTRL). In red the exposure period (or a corresponding period for CTRL). Data are presented as mean \pm S.D..

the peak amplitude trend for the 3 groups: control group (CTRL), 2W/kg GSM and 4 W/kg GSM exposed groups, respectively.

Time intervals before and after TBS (time steps of 5 minutes) were considered.

Differences between pre-exposure and post-exposure (the analogous for CTRL slices) were considered for the analysis. The post TBS period was divided in 5 minutes interval.

More specifically, for each slice, the following differences were considered: average of values from minute 20 to 25 minus the average of the values corresponding to the 10 minutes before exposure (I difference); average of values from minute 25 to 30 minus the average of the values corresponding to the 10 minutes before exposure (II difference); a two way ANOVA for repeated measurements was performed on these differences.

The factors of variation for the ANOVA were: 2 kinds of exposures (CTRL, 2 W/kg GSM, 4 W/kg GSM) and the variations between differences.

Since the scientific target was to evaluate possible effects of RF on the amplitude of the LTP, the LTP induction efficiency was taken into account. Efficiency has been defined as ratio between "number of slices with potentiation" and "number of slices with TBS". In table 2 efficiency values are reported for each kind of exposure.

Type of Exposure	Total number of slices with TBS	Total number of slices with potentiation	Efficiency (%)
CTRL Group	11	7	63.6
GSM 2W/kg Group	10	7	70.0
GSM 4W/kg Group	9	5	55.6

Tab. 2

The success percentage was above the 55% for any groups, independently from the different exposures.

No statistical significant variations were found between the differences ($p=0.99$), indicating that no change in peak amplitude occurred during the 10 minutes after the TBS for each group; A statistical significant p value was found in peak amplitude variation depending on the exposure conditions (figure 58 and 59).

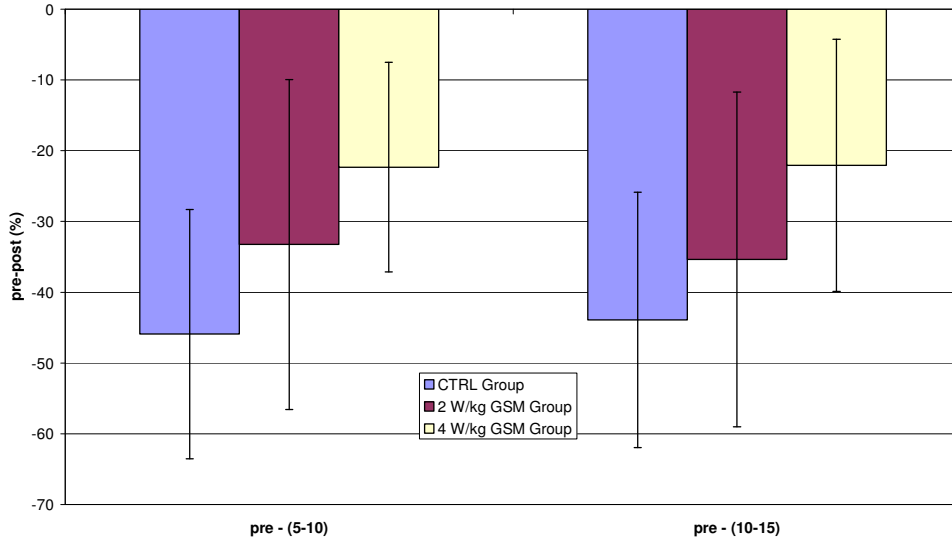

Fig. 58: Differences in the 3 groups. Data are presented as mean \pm S.D

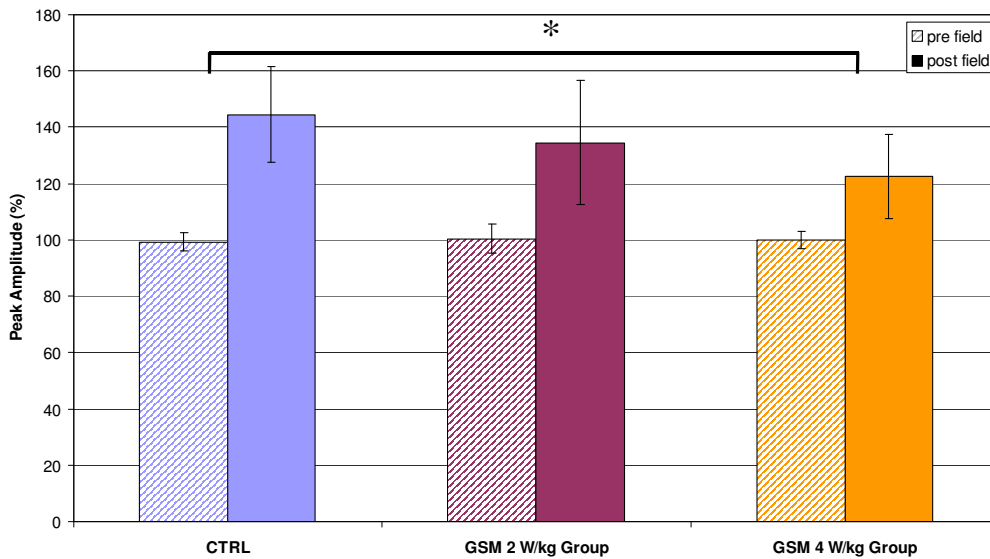

Fig. 59 Peak amplitude in the 3 groups (CTRL; 2 W/kg GSM and 4 W/kg GSM) before and after the exposure. Data are presented as mean \pm S.D. Statistically significant difference is indicated with asterisk

A post hoc test (dunn sidak) has showed that the statistical significant difference was between the variation in the 4 W/kg GSM group versus CTRL group (figure 60).

The difference was of the order of 21% between CTRL and 4 W/kg exposed slices

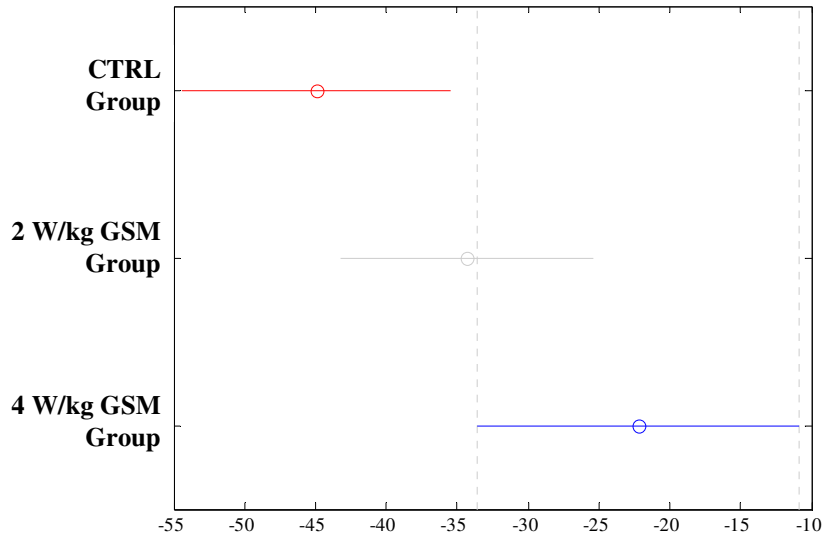

Fig. 60: average value of the differences in CTRL, 2 W/kg GSM and 4 W/kg GSM groups.

Results were also confirmed using the Friedman's test.

However, in order to conclude this research more experiments must be performed in all the conditions tested, in order to reach the number of experiments calculated by the “a priori” statistical power.

CHAPTER 4

CONCLUSIONS and DISCUSSION

4.1 ELF EXPERIMENTS

4.1.1. Synaptic transmission

The main result of this study is that 1 hour 50 Hz EMF exposure significantly affects the stability of the synaptic transmission response in the rat perirhinal cortex. There was a persistent increase in the coefficient of variation in exposed compared to non exposed slices. Moreover this increase was intensity-dependent.

However, no statistically significant differences were found studying the amplitude of the field potential (as average values) both in slices exposed to 2.3 mT and 1.0 mT for 1 hour.

4.1.2 LTP

Concerning the experiments aimed to evaluate ELF effects on LTP maintenance in rat perirhinal cortex, no statistically significant differences were found in field potential peak amplitudes in exposed (sinusoidal 2.3 mT 50 Hz, 30 minutes) versus not exposed slices. Moreover, no differences were found concerning the variability of the response.

4.2 RF EXPERIMENTS

4.2.1 Synaptic transmission

Concerning RF EMF exposure in some cases statistically significant differences were found in field potential peak amplitude following 1 hour exposure to 2 W/kg 900 MHz CW and in experiments with 5 minutes exposure to 2 or 4 W/kg 900 MHz GSM. However the entity of the peak amplitude differences was small: 4% in CW 1 hour

experiments (CTRL versus exposed) and around 5 % in GSM 2 W/kg exposed slices versus 4 W/kg GSM slices (no statistical significance difference between GSM exposed and CTRL).

Thus, the differences were well below the value indicated by the a priori statistical power analysis (10%).

4.2.2 LTP

Concerning this end point, experiments are in progress in order to achieve the number of slices requested by the “a priori” statistical power analysis to demonstrate, with a power of 0.8, a difference of at least 25% between exposed and control slices, at a 0.05 level of significance.

Preliminary results obtained until now show a statistically significant difference in the amplitude of LTP in slices exposed to 4 W/kg GSM for 5 minutes compared to CTRL. There was a reduction on the amplitude of the potentiation of about 20 %. The same trend of reduction was also observed in the 2 W/kg GSM exposed slices, but it was not statistically significant.

In these kind of experiments (both ELF and RF) a critical role is played by the temperature. In particular, it plays a critical role in the two following phases. 1) during the slice preparation; 2) during EMF exposure.

1. As a matter of fact, it has been demonstrated in hippocampus rat brain slices that subtle changes in the temperature at which slices were incubated (incubation means the time during which slice recovers from the stress induced by the cut) had significant effects on extracellularly recorded field potentials, in term of their stability over time (Watson et al, 1997). An analogous effect was found also in rats perirhinal cortex brain slices (Moyer J.R. and Brown T.H, 1998). In our experimental conditions the incubation of slices after the cut lasted 1 hour in

ACFS at room temperature (that was not maintained constant through all the experiments).

2. It has been demonstrated that sensible increase in temperature of about 3-4 °C during recordings causes a sensible reduction in field potential peak amplitude in hippocampal slices from rat (Masino S.A. and Dunwiddie T.V., 1999; 2000; Pakhomov A.G. et al., 2003) and from guinea pig (Fujii S. et al., 2002). In our condition we can rule out such a big increase in temperature, but we can not rule out, especially for 1 hour exposure, variation in temperature of the order of some tenths of degree.

In our experiments:

- a. slices were incubated at room temperature. This makes it possible that different slices were incubated at different temperatures, leading to possible different responses from experiments to experiments.
- b. concerning the exposure conditions the different in temperature are generally very small, so that we do not expect temperature effects on peak amplitude at variance with those found in the studies quoted above.

From these considerations, the effect that can be attributed to EMF with a sufficient confidence is the one concerning the reduction of LTP amplitude in slices exposed to 4 W/kg. Actually, here we can reasonable exclude a thermal effect because the TBS is delivered 10 minutes after the 5 minutes RF exposure, and thus, such effect is certainly not due to possible increase of temperature, if any, linked to such exposure. Moreover, in these experiments the slice, immediately after the exposure, did not show any differences in peak amplitude neither versus the pre exposure values or versus CTRL slices.

In conclusion, these results strongly suggest that ELF EMF exposure produces a significant, even if slight, fluctuation in the electrophysiological response, in particular in the synaptic transmission. On the contrary RF EMF exposure does not appear to affect in some way the synaptic transmission or the LTP, except a remarkable decrease in the amplitude of LTP for the case of the

highest SAR (4 W/kg), but these results must be statistically corroborated by further experiments. The physiological meaning and interpretation of the reported fluctuation is unclear so far.

4.3 FUTURE PERSPECTIVES

This research will be completed by further electrophysiological experiments and by a series of temperature measurements, also using a very sensitive thermo-camera, in order to totally exclude possible artefacts due to temperature effects. Further work is needed in order to clarify the physiological meaning of the effect reported.

(A further line of research, which must be developed in the future, will be focused on the measurements of action potential and possible effect on its frequency in spontaneously firing neurons.)

REFERENCES

"Electricity and Magnetism in Biology and Medicine", F. Bersani Ed., Kluwer Academic/Plenum Publishers, New York, USA, 1999.

Adair RK. "Constraints on biological effects of weak extremely-low-frequency electromagnetic fields", *Phys Rev A.*, 43(2): 1039-1048, 1991.

Adey WR. "Cell and Molecular Biology Associated with Radiation Fields of Mobile Telephones", in: "Review of Radiosceince 1996-1999", W. R. Stone Ed., Oxford University Press, Oxford, UK, 1999, pp 845-72.

Aicardi G, Argilli E, Cappello S, Santi S, Riccio M, Thoenen H, Canossa M. "Induction of long-term potentiation and depression is reflected by corresponding changes in secretion of endogenous brain-derived neurotrophic factor", *Proc. Natl. Acad. Sci. USA*,101(44): 15788-92, 2004

Apollonio F, Liberti M, D'Inzeo G, Tarricone L. Integrated models for the analysis of biological effects of EM fields used for mobile communications", *IEEE Transactions on Microwave Theory and Techniques*, 48(11) Part 2: 2082-93, 2000.

Bao X, Shi Y, Huo X, Song T. "A possible involvement of beta-endorphin, substance P, and serotonin in rat analgesia induced by extremely low frequency magnetic field", *Bioelectromagnetics*, 27(6): 467-72, 2006.

Bawin SM, Satmary WM, Jones RA, Adey WR, Zimmerman G. "Extremely-low-frequency magnetic fields disrupt rhythmic slow activity in rat hippocampal slices", *Bioelectromagnetics*, 17(5): 388-95, 1996.

Bersani F, Marinelli F, Ognibene A, Matteucci A, Cecchi S, Santi S, Squarzoni S, Maraldi NM. "Intramembrane protein distribution in cell cultures is affected by 50 Hz pulsed magnetic fields", *Bioelectromagnetics*, 18(7): 463-9, 1997.

Bilkey DK. "Long-term potentiation in the in vitro perirhinal cortex displays associative properties", *Brain Res.*, 733(2): 297-300, 1996.

Bliss TV, Lomo T. "Long-lasting potentiation of synaptic transmission in the dentate area of the anaesthetized rabbit following stimulation of the perforant path", *J. Physiol.*, 232(2): 331-56, 1973.

Brown K. "Animal magnetism guides migration", *Science*, 294(5541): 283-84, 2001.

Bunsey M, Eichenbaum H. "Critical role of the parahippocampal region for paired-associate learning in rats", *Behav. Neurosci.*, 107(5): 740-7, 1993.

Burwell RD, Amaral DG. "Cortical afferents of the perirhinal, postrhinal, and entorhinal cortices of the rat", *J. Comp. Neurol.*, 398(2): 179-205, 1998.

Cadossi R, Bersani F, Cossarizza A, Zucchini P, Emilia G, Torelli G, Franceschi C. "Lymphocytes and low-frequency electromagnetic fields", *FASEB J.*, 6(9): 2667-74, 1992.

Campeau S, Davis M. "Involvement of subcortical and cortical afferents to the lateral nucleus of the amygdala in fear conditioning measured with fear-potentiated startle in rats trained concurrently with auditory and visual conditioned stimuli", *J. Neurosci.*, 15(3 Pt 2): 2312-27, 1995.

Chiabrera A, Bianco B, Moggia E, Kaufman JJ. "Zeeman-Stark modeling of the RF EMF interaction with ligand binding", *Bioelectromagnetics*, 21(4): 312-24, 2000.

Corodimas KP, LeDoux JE. "Disruptive effects of posttraining perirhinal cortex lesions on conditioned fear: contributions of contextual cues", *Behav. Neurosci.*, 109(4): 613-9, 1995.

Cossarizza A, Monti D, Bersani F, Cantini M, Cadossi R, Sacchi A, Franceschi C. "Extremely low frequency pulsed electromagnetic fields increase cell proliferation in lymphocytes from young and aged subjects", *Biochem Biophys Res Commun.*, 160(2): 692-8, 1989.

Cossarizza A, Monti D, Bersani F, Paganelli R, Montagnani G, Cadossi R, Cantini M, Franceschi C. "Extremely low frequency pulsed electromagnetic fields increase interleukin-2 (IL-2) utilization and IL-2 receptor expression in mitogen-stimulated human lymphocytes from old subjects", *FEBS Lett.*, 248(1-2): 141-4, 1989.

Cossarizza A, Monti D, Bersani F, Scarfi MR, Zanotti M, Cadossi R, Franceschi C. "Exposure to low-frequency pulsed electromagnetic fields increases mitogen-induced lymphocyte proliferation in Down's syndrome", *Aging (Milano)*, 3(3): 241-6, 1991.

Council Recommendation of the July 1999 on the limitation exposure of the general public to electromagnetic fields (0 Hz to 300 GHz). (1999/519/EC). *Official Journal of the European Communities*. 20.7.1999.L199/59-70.

D'Andrea JA, Chou CK, Johnston SA, Adai ER., "Microwave effects on the nervous system", *Bioelectromagnetics*, 24(S6): S107-S147, 2003.

Espinosa JM, Liberti M, Lagroye I, Veyret B. "Exposure to AC and DC magnetic fields induces changes in 5-HT_{1B} receptor binding parameters in rat brain membranes", *Bioelectromagnetics*, 27(5): 414-22, 2006.

Fanelli C, Coppola S, Barone R, Colussi C, Gualandi G, Volpe P, Ghibelli L. "Magnetic fields increase cell survival by inhibiting apoptosis via modulation of Ca²⁺ influx", *FASEB J.*, 13(1): 95-102, 1999.

Foster KR, Lozano-Nieto A, Riu PJ, Ely TS. "Heating of tissues by microwaves: a model analysis", *Bioelectromagnetics*, 19(7): 420-8, 1998.

Foster KR, Vecchia P, Repacholi MH. "Risk management. Science and the precautionary principle", *Science*, 288(5468): 979-81, 2000.

Fujii S, Sasaki H, Ito K, Kaneko K, Kato H. "Temperature dependence of synaptic responses in Guinea pig hippocampal CA1 neurons in vitro", *Cell. Mol. Neurobiol.*, 22(4): 379-91, 2002.

Gaffan D, Parker A. "Interaction of perirhinal cortex with the fornix-fimbria: memory for objects and "object-in-place" memory", *J. Neurosci.*, 16(18): 5864-9, 1996.

Gaffan EA, Healey AN, Eacott MJ. "Objects and positions in visual scenes: effects of perirhinal and postrhinal cortex lesions in the rat", *Behav. Neurosci.*, 118(5): 992-1010, 2004.

Holian O, Astumian RD, Lee RC, Reyes HM, Attar BM, Walter RJ. "Protein kinase C activity is altered in HL60 cells exposed to 60 Hz AC electric fields", *Bioelectromagnetics*, 17(6): 504-9, 1996.

Ibach B, Haen E. "Acetylcholinesterase inhibition in Alzheimer's Disease", *Curr. Pharm .Des.*, 10(3): 231-51, 2004.

Jelenkovic A, Janac B, Pesic V, Jovanovic MD, Vasiljevic I, Prolic Z. "The effects of exposure to extremely low-frequency magnetic field and amphetamine on the reduced glutathione in the brain", *Ann. N. Y. Acad. Sci.*, 1048: 377-80, 2005.

Kandel ER, Schwartz JH, Jessel TM. "Principles of neural science", Third edition, Prentice Hall International, London, UK, 1991.

Karabakhtsian R, Broude N, Shalts N, Kochlatyi S, Goodman R, Henderson AS. "Calcium is necessary in the cell response to EM fields", *FEBS Lett.*, 349(1): 1-6, 1994.

Kavaliers M, Eckel LA, Ossenkopp KP. "Brief exposure to 60 Hz magnetic fields improves sexually dimorphic spatial learning performance in the meadow vole, *Microtus pennsylvanicus*", *J. Comp. Physiol. A*, 173(2): 241-8, 1993.

Kirschvink JL. "Uniform magnetic fields and double-wrapped coil systems: improved techniques for the design of bioelectromagnetics experiments", *Bioelectromagnetics*, 13(5): 401-11, 1992

Koivisto M, Krause CM, Revonsuo A, Laine M, Hamalainen H. "The effects of electromagnetic field emitted by GSM phones on working memory", *Neuroreport*, 11(8): 1641-3, 2000.

Krause CM, Sillanmaki L, Koivisto M, Haggqvist A, Saarela C, Revonsuo A, Laine M, Hamalainen H. "Effects of electromagnetic field emitted by cellular phones on the EEG during a memory task", *Neuroreport*, 11(4): 761-4, 2000.

Kruglikov IL, Dertinger H. "Stochastic resonance as a possible mechanism of amplification of weak electric signals in living cells", *Bioelectromagnetics*, 15(6): 539-47, 1994.

Lai H, Carino M. "60 Hz magnetic fields and central cholinergic activity: effects of exposure intensity and duration", *Bioelectromagnetics*, 20(5): 284-9, 1999.

Lai H, Carino MA, Ushijima I. "Acute exposure to a 60 Hz magnetic field affects rats' water-maze performance", *Bioelectromagnetics*, 19(2): 117-22, 1998.

Lai H. "Spatial learning deficit in the rat after exposure to a 60 Hz magnetic field", *Bioelectromagnetics*, 17(6): 494-6, 1996.

Lednev VV. "Comments on "Clarification and application of ion parametric resonance model for magnetic field interactions with biological systems" by Blanchard and Blackman", *Bioelectromagnetics*, 16(4): 268-9, discussion 270-5, 1995.

Liberti M, Apollonio F, Paffi A, Pellegrino M, D'Inzeo G. "A coplanar-waveguide system for cells exposure during electrophysiological recordings", *IEEE Transactions on Microwave Theory and Techniques*, 52(11): 2521-28, 2004.

Liboff AR. "Electric-field ion cyclotron resonance", *Bioelectromagnetics*, 18(1): 85-7, 1997.

Liburdy RP, Callahan DE, Harland J, Dunham E, Sloma TR, Yaswen P. "Experimental evidence for 60 Hz magnetic fields operating through the signal transduction cascade. Effects on calcium influx and c-MYC mRNA induction", *FEBS Lett.*, 334(3): 301-8, 1993.

Lilliefors HW. "On the Kolmogorov-Smirnov test for normality with mean and variance unknown", *J. Am. Stat. Ass.*, 62(318): 399-402, 1967.

Litvak E, Foster KR, Repacholi MH. "Health and safety implications of exposure to electromagnetic fields in the frequency range 300 Hz to 10 MHz", *Bioelectromagnetics*, 23(1): 68-82, 2002.

Liu P, Bilkey DK. "The effect of excitotoxic lesions centered on the perirhinal cortex in two versions of the radial arm maze task", *Behav. Neurosci.*, 113(4): 672-82, 1999.

Longo FM, Yang T, Hamilton S, Hyde JF, Walker J, Jennes L, Stach R, Siskin BF. "Electromagnetic fields influence NGF activity and levels following sciatic nerve transection", *J. Neurosci Res.*, 55(2): 230-7, 1999.

Masino SA, Dunwiddie TV. "Temperature-dependent modulation of excitatory transmission in hippocampal slices is mediated by extracellular adenosine", *J. Neurosci.*, 19(6): 1932-39, 1999.

Masino SA, Dunwiddie TV. "A transient increase in temperature induces persistent potentiation of synaptic transmission in rat hippocampal slices", *Neurosci.*, 101(4): 907-12, 2000.

Massot O, Grimaldi B, Bailly JM, Kochanek M, Deschamps F, Lambrozo J, Fillion G. "Magnetic field desensitizes 5-HT(1B) receptor in brain: pharmacological and functional studies", *Brain Res.*, 858(1): 143-50, 2000.

Mausset AL, de Seze R, Montpeyroux F, Privat A. "Effects of radiofrequency exposure on the GABAergic system in the rat cerebellum: clues from semi-quantitative immunohistochemistry", *Brain Res.*, 912(1): 33-46, 2001.

Molfetta S, Apollonio F, Liberti M, D’Inzeo G. “Low cost exposure set-up for RF biological experiments”, Abstract Book 6th EBEA Congress, pag. 132, 13-15 November 2003, Budapest, Hungary.

Moyer JR, Brown TH. “Methods for whole-cell recording from visually preselected neurons of perirhinal cortex in brain slices from young and aging rats”, *J. Neurosci. Methods*, 86: 35-54, 1998.

Mumby DG, Glenn MJ. “Anterograde and retrograde memory for object discriminations and places in rats with perirhinal cortex lesions”, *Behav. Brain Res.*, 114(1-2): 119-34, 2000.

Nemec P, Altmann J, Marhold S, Burda H, Oelschläger HH. "Neuroanatomy of magnetoreception: the superior colliculus involved in magnetic orientation in a mammal", *Science*, 294(5541): 366-8, 2001.

Pakhomov AG, Doyle J, Stuck BE, Murphy MR. “Effects of high power pulses on synaptic transmission and long term potentiation in hippocampus”, *Bioelectromagnetics*, 24(3): 174-81, 2003.

Pellegrino M, Paffi A, Beccherelli R, Liberti M, Apollonio F, D’Inzeo G. “A real-time exposure system for electrophysiological recordings from brain slices: design and realization”, Abstract Book 29th BEMS Meeting, pag 525-28, 19-24 June 2005, Dublin, Ireland

Preece AW, Iwi G, Davies-Smith A, Wesnes K, Butler S, Lim E, Valey A. "Effect of a 915-MHz simulated mobile phone signal on cognitive function in man", *Int J Radiat Biol.*, 75(4): 447-56, 1999.

Repacholi MH, Greenebaum B. "Interaction of static and extremely low frequency electric and magnetic fields with living systems: health

effects and research needs", *Bioelectromagnetics*, 20(3): 133-60, 1999.

Reyes-Guerrero G, Vazquez-Garcia M, Elias-Vinas D, Donatti-Albarran OA, Guevara-Guzman R. "Effects of 17 β -estradiol and extremely low-frequency electromagnetic fields on social recognition memory in female rats: a possible interaction?", *Brain Res.*, 1095(1): 131-8, 2006.

Sienkiewicz ZJ, Haylock RG, Bartrum R, Saunders RD. "50 Hz magnetic field effects on the performance of a spatial learning task by mice", *Bioelectromagnetics*, 19(8): 486-93, 1998.

Squire LR, Zola SM. "Structure and function of declarative and nondeclarative memory systems", *Proc. Natl. Acad. Sci. USA*, 93(24): 13515-22, 1996.

Suzuki WA, Zola-Morgan S, Squire LR, Amaral DG. "Lesions of the perirhinal and parahippocampal cortices in the monkey produce long-lasting memory impairment in the visual and tactual modalities", *J. Neurosci.*, 13(6): 2430-51, 1993.

Suzuki WA. "The anatomy, physiology and functions of the perirhinal cortex", *Curr. Opin. Neurobiol.*, 6(2): 179-86, 1996.

Tattersall JE, Scott IR, Wood SJ, Nettell JJ, Bevir MK, Wang Z, Somasiri NP, Chen X. "Effects of low intensity radiofrequency electromagnetic fields on electrical activity in rat hippocampal slices", *Brain Res*, 904(1): 43-53, 2001.

Tonini R, Baroni MD, Masala E, Micheletti M, Ferroni A, Mazzanti M. "Calcium protects differentiating neuroblastoma cells during 50 Hz electromagnetic radiation", *Biophys J.*, 81(5): 2580-9, 2001.

Ury HK. "A comparison of four procedures for multiple comparisons among means (pairwise contrasts) for arbitrary sample sizes", *Technometrics*, 18(1): 89-97, 1976.

Varani K, Gessi S, Merighi S, Iannotta V, Cattabriga E, Pancaldi C, Cadossi R, Borea PA. "Alteration of A(3) adenosine receptors in human neutrophils and low frequency electromagnetic fields", *Biochem Pharmacol.*, 66(10): 1897-906, 2003.

Ventura C, Maioli M, Asara Y, Santoni D, Mesirca P, Remondini D, Bersani F. "Turning on stem cell cardiogenesis with extremely low frequency magnetic fields", *FASEB J.*, 19(1): 155-7, 2005.

Ventura C, Maioli M, Pintus G, Gottardi G, Bersani F. "Elf-pulsed magnetic fields modulate opioid peptide gene expression in myocardial cells", *Cardiovasc Res.*, 45(4): 1054-64, 2000.

Watson PL, Weiner JL, Carle, PL. "Effects on variations in hippocampal slice preparation protocol on the electrophysiological stability, epileptogenicity and graded hypoxia responses of CA1 neurons", *Brain Res.*, 775: 134-43, 1997.

Wiig KA, Cooper LN, Bear MF. "Temporally graded retrograde amnesia following separate and combined lesions of the perirhinal cortex and fornix in the rat", *Learn. Mem.*, 3(4): 313-25, 1996.

Zhou J, Yao G, Zhang J, Chang Z. "CREB DNA binding activation by a 50-Hz magnetic field in HL60 cells is dependent on extra- and intracellular Ca²⁺ but not PKA, PKC, ERK, or p38 MAPK", *Biochem. Biophys. Res. Comm.*, 296(4): 1013-8, 2002.

Ziakopoulos Z, Tillett CW, Brown MW, Bashir ZI. "Input-and layer-dependent synaptic plasticity in the rat perirhinal cortex in vitro", *Neuroscience* 92(2): 459-72, 1999

Zirani I, Buckley MJ, Gaffan DR, Bussey TJ, Bussey TJ, Bussey TJ. "Prefrontal cortex lesions augment the location-related firing properties of area TE/perirhinal cortex neurons in a working memory task", *Cereb. Cortex.*, 11(11): 1093-100, 2001.

Zola-Morgan S, Squire LR, Amaral DG, Suzuki WA. "Lesions of perirhinal and parahippocampal cortex that spare the amygdala and hippocampal formation produce severe memory impairment", *J. Neurosci.*, 9(12): 4355-70, 1989.

APPENDIX A

A.1 SYNAPTIC TRANSMISSION

The synaptic transmission is the communication between nervous cells by means of synapses.

The synaptic membrane contains, unlike other areas of the nervous fibre, a large amount of voltage gated calcium channels. When action potential depolarises the pre-synaptic terminal, a great number of calcium ions enters the membrane.

The increase of calcium ions concentration allows the vesicles containing neurotransmitters (the most present at central nervous system (CNS) level is glutamate) (figure A1.a) to approach and to melt into membrane. The melting of synaptic vesicles causes the exocytose of the neurotransmitters in the synaptic cleft (figure A1.b). Neurotransmitters, after diffusion in the synaptic cleft, bind themselves to specific receptors placed on the post synaptic membrane (figure A1.c). The process by which the neurotransmitter bind himself to receptors, produces the opening or the closing of post synaptic membrane channels. The flux of current, induced by neurotransmitters, alters the post synaptic membrane potential, increasing or decreasing the probability that the neuron generates an action potential.

After that, the neurotransmitters are released from the receptors and diffused back into the synaptic cleft (figure A1.d) and re-absorbed by the pre synaptic neuron (process known as “re-uptake”) (figure A1.e) (Purves D. et al., 2000).

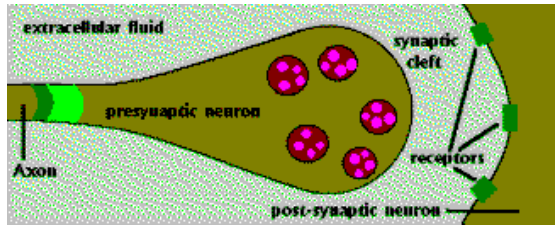

Fig. A1.a

Fig. A1.b

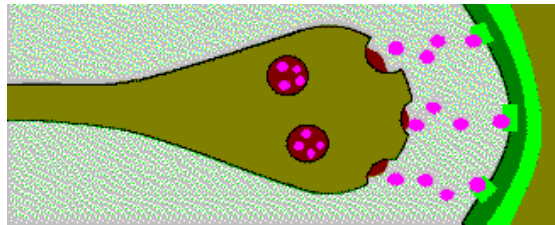
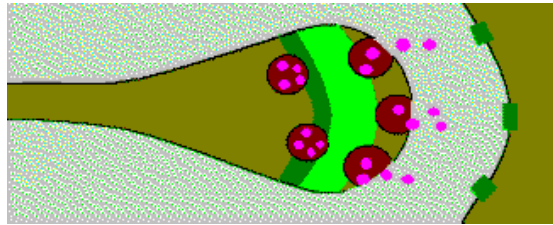

Fig. A1.c

Fig. A1.d

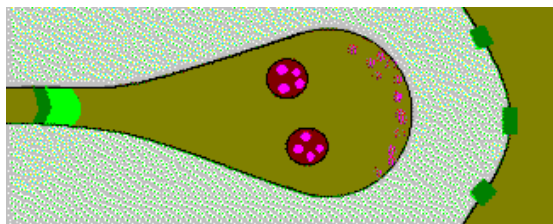
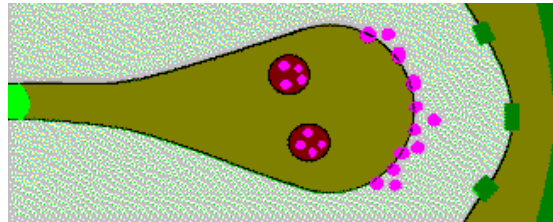
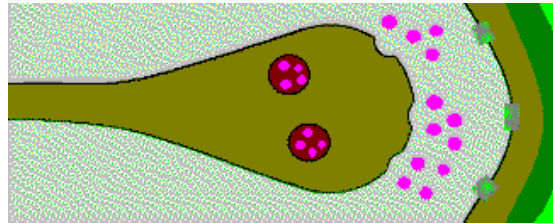

Fig. A1.e

Fig. A1: the general process of synaptic transmission:

A.2 SYNAPTIC PLASTICITY

Synapses, i.e. sites of communication between neurons, have an active role in the formation and conservation of memory traces.

They are characterized by a great ability in changing, both for short and long period, the efficiency of chemical transmission. This ability is defined as “synaptic plasticity” and it is deeply involved in the memory and learning processes. Synaptic plasticity is a very complex phenomenon that can be investigated by different and complementary approaches: electrophysiological, molecular and morphological.

A.2.1 LTP

The structural plasticity, namely the CNS capability to develop and re-organize after experiences, has been linked to the long term memory. The consolidation process of new memories causes anatomic changes in the involved cerebral areas. For instance, experiments performed on monkeys confirmed that cortical maps are constantly prone to alterations due to the use of the sensory ways. Other phenomena of structural plasticity have been connected to learning processes in the sea-mollusc *Aplysia* (Kandel E.R. et al., 1991).

The most studied form of synaptic plasticity is the “long term potentiation” (LTP), discovered in 1973 by Bliss and Lømo (Bliss T.V. and Lømo T., 1973) during experiments on synaptic transmission in rabbit.

LTP consists in an increase of the synaptic response as a consequence of a single stimulus; the increase is induced by short, high frequency stimulations.

In vigil animals LTP can last days or weeks, while in *in vitro* samples, it can last several hours. If the duration of potentiation is between 5 and 20 minutes, it is called short term potentiation (STP). Moreover, LTP is called “early” (E-LTP) if persists, stable, from a period ranging from 30 minutes to 3 hours and is called “late” (L-LTP) if it persists up to 8 hours.

Obviously, these temporal differences involve also differences at molecular mechanism level. In particular, the L-LTP implies synthesis of new proteins and, as consequence, a change in gene expression (Soderling T.R. and Derkach V.A., 2000).

A.2.2 LTD

Another type of synaptic plasticity is the so called “long term depression” (LTD). It has characteristics complementary to LTP: it is induced by prolonged, low frequency stimulations and causes a weakening in the efficacy of the synaptic transmission. Also in LTD, differences exist based on duration of the “depression”: if the duration of the depression lasts up to 30 minutes, it is called short term depression (STD) (Castro-Alamancos M.A. et al., 1995).

A.3 REFERENCES

Castro-Alamancos MA, Donoghue JP, Connors BW. “Different forms of synaptic plasticity in somatosensory and motor areas of the neocortex”, *J Neurosci.*, 15(7 Pt 2): 5324-33, 1995.

Kandel ER, Schwartz JH, Jessel TM. "Principles of neural science", Third edition, Prentice Hall International, London, UK, 1991.

Purves D, Augustine GJ, Fitzpatrick D, Katz LC, LaMantia AS, McNamara JO. “Neuroscienze”, a cura di, Zanichelli ed., Bologna, Italia, 2000.

Soderling TR and Derkach VA. “Postsynaptic protein phosphorylation and LTP”, *Trends Neurosci.*, 23(2): 75-80, 2000.