



Swansea University
Prifysgol Abertawe



Cronfa - Swansea University Open Access Repository

This is an author produced version of a paper published in:

Physical Review D

Cronfa URL for this paper:

<http://cronfa.swan.ac.uk/Record/cronfa36320>

Paper:

Dunbar, D., Godwin, J., Jehu, G. & Perkins, W. (2017). Analytic all-plus-helicity gluon amplitudes in QCD. *Physical Review D*, 96(11)

<http://dx.doi.org/10.1103/PhysRevD.96.116013>

This item is brought to you by Swansea University. Any person downloading material is agreeing to abide by the terms of the repository licence. Copies of full text items may be used or reproduced in any format or medium, without prior permission for personal research or study, educational or non-commercial purposes only. The copyright for any work remains with the original author unless otherwise specified. The full-text must not be sold in any format or medium without the formal permission of the copyright holder.

Permission for multiple reproductions should be obtained from the original author.

Authors are personally responsible for adhering to copyright and publisher restrictions when uploading content to the repository.

<http://www.swansea.ac.uk/library/researchsupport/ris-support/>

Analytic all-plus gluon amplitudes in QCD

David C. Dunbar, John H. Godwin, Guy R. Jehu and Warren B. Perkins

*College of Science,
Swansea University,
Swansea, SA2 8PP, UK
November 19, 2017*

Abstract

We detail the calculation of two-loop all-plus helicity amplitudes for pure Yang-Mills theory. The four dimensional unitarity methods and augmented recursion techniques we have developed, together with a knowledge of the singular structure of the amplitudes allow us to compute these in compact analytic forms. Specifically we present the computation and analytic results for the six- and seven-gluon leading colour two-loop amplitudes these being the first QCD two-loop amplitudes beyond five-points.

PACS numbers: 04.65.+e

I. INTRODUCTION

Perturbative scattering amplitudes are a key element in confronting particle theories with experiment. In doing so there is a need for precise theoretical predictions which require matrix elements beyond the "leading order" (LO) and for many processing beyond "next-to-leading order" (NLO) [1, 2]. These scattering amplitudes are challenging to compute due to both the proliferation of diagrams and the complexity of the associated integrals.

Enormous progress has been made in computing scattering amplitudes in maximally supersymmetric Yang-Mills using the enhanced symmetry together with calculations based upon the singular structure of the amplitude (for example [3]). However it is an open question as to whether these techniques can be used in non-supersymmetric theories. These methods utilise a knowledge of the factorisation properties of the amplitude [4, 5]; the unitarity of the S -matrix and its associated cut singularities [6, 7]; and the general singular behaviour in the "Infra-Red" (IR) and "Ultra-Violet" (UV) [8].

In this article we demonstrate the computation of a very specific two-loop amplitude in pure Yang-Mills theory where the external gluons all have the same helicity (all-plus) and we consider the leading in colour component. For two-loop QCD the four-point amplitude has been computed analytically for all helicity configurations [9, 10] and numerically using unitary techniques [11]. Recently, the first five-point two-loop amplitude for the all-plus helicity configuration was obtained using D -dimensional unitarity¹ to generate the integrands of loop integral functions [12, 13]. In [14] the amplitude was recomputed using four dimensional unitarity techniques together with factorisation properties of the amplitude rather than the integrand. In [15] we presented the result of applying this approach to computing the six-point all-plus helicity amplitude. In this article we detail this construction and present both the six- and seven-point all-plus helicity amplitudes. The expression for these are compact analytic formulae.

II. THE ALL-PLUS HELICITY AMPLITUDE

First we review the all-plus helicity amplitude. The all-plus helicity amplitude at leading colour may be written²

$$\begin{aligned} \mathcal{A}_n(1^+, 2^+, \dots, n^+) |_{\text{leading color}} &= g^{n-2} \sum_{L \geq 1} (g^2 N_c c_\Gamma)^L \times \sum_{\sigma \in S_n/Z_n} \text{tr}(T^{a_{\sigma(1)}} T^{a_{\sigma(2)}} T^{a_{\sigma(3)}} \dots T^{a_{\sigma(n)}}) \\ &\times A_n^{(L)}(\sigma(1)^+, \sigma(2)^+, \dots, \sigma(n)^+) \end{aligned} \quad (2.1)$$

where N_c is the number of colours and the summation is over the set of non-cyclic permutations, S_n/Z_n .

The tree amplitude vanishes as a consequence of supersymmetric Ward identities so the

¹ where $D = 4 - 2\epsilon$.

² The factor c_Γ is defined as $\Gamma(1 + \epsilon)\Gamma^2(1 - \epsilon)/\Gamma(1 - 2\epsilon)/(4\pi)^{2-\epsilon}$.

leading contribution is the one-loop amplitude which, is given by [16]³,

$$A_n^{(1)}(1^+, 2^+, \dots, n^+) = -\frac{i}{3} \sum_{1 \leq k_1 < k_2 < k_3 < k_4 \leq n} \frac{\langle k_1 k_2 \rangle [k_2 k_3] \langle k_3 k_4 \rangle [k_4 k_1]}{\langle 1 2 \rangle \langle 2 3 \rangle \dots \langle n 1 \rangle} + O(\epsilon). \quad (2.2)$$

This expression is rational to order ϵ^0 . All- ϵ forms of the one-loop amplitudes are given in terms of higher dimensional scalar integrals and for $n \leq 6$ are [18]

$$A_4^{(1)}(1^+, 2^+, 3^+, 4^+) = \frac{2i\epsilon(1-\epsilon)}{\langle 1 2 \rangle \langle 2 3 \rangle \langle 3 4 \rangle \langle 4 1 \rangle} \times s_{12}s_{23}I_4^{D=8-2\epsilon},$$

$$\begin{aligned} A_5^{(1)}(1^+, 2^+, 3^+, 4^+, 5^+) &= \frac{i\epsilon(1-\epsilon)}{\langle 1 2 \rangle \langle 2 3 \rangle \langle 3 4 \rangle \langle 4 5 \rangle \langle 5 1 \rangle} \\ &\times \left[s_{23}s_{34}I_4^{(1),D=8-2\epsilon} + s_{34}s_{45}I_4^{(2),D=8-2\epsilon} + s_{45}s_{51}I_4^{(3),D=8-2\epsilon} \right. \\ &\left. + s_{51}s_{12}I_4^{(4),D=8-2\epsilon} + s_{12}s_{23}I_4^{(5),D=8-2\epsilon} + (4-2\epsilon)\varepsilon(1, 2, 3, 4)I_5^{D=10-2\epsilon} \right], \end{aligned}$$

$$\begin{aligned} A_6^{(1)}(1^+, 2^+, 3^+, 4^+, 5^+, 6^+) &= \frac{i\epsilon(1-\epsilon)}{\langle 1 2 \rangle \langle 2 3 \rangle \langle 3 4 \rangle \langle 4 5 \rangle \langle 5 6 \rangle \langle 6 1 \rangle} \frac{1}{2} \left[\right. \\ &- \sum_{1 \leq i_1 < i_2 \leq 6} \text{tr}[k_{i_1} \bar{K}_{i_1+1, i_2-1} k_{i_2} \bar{K}_{i_2+1, i_1-1}] I_4^{(i_1, i_2), D=8-2\epsilon} + (4-2\epsilon) \text{tr}[123456] I_6^{D=10-2\epsilon} \\ &\left. + (4-2\epsilon) \sum_{i=1}^6 \varepsilon(i+1, i+2, i+3, i+4) I_5^{(i), D=10-2\epsilon} \right], \quad (2.3) \end{aligned}$$

where $I_m^{(i), D}$ denotes the D dimensional scalar integral obtained by removing the loop propagator between legs $i-1$ and i from the $(m+1)$ -point scalar integral etc. [19], $\bar{K}_{a,b} \equiv \sum_{i=a}^b k_i$ and $\varepsilon(a, b, c, d) = [ab] \langle bc \rangle [cd] \langle da \rangle - \langle ab \rangle [bc] \langle cd \rangle [da]$.

The subject of this computation is the two-loop partial amplitude $A_n^{(2)}(1^+, 2^+, \dots, n^+)$. This particular partial amplitude has full cyclic symmetry and flip symmetry,

$$A_n^{(2)}(1^+, 2^+, \dots, n^+) = (-1)^n A_n^{(2)}(n^+, \dots, 2^+, 1^+). \quad (2.4)$$

The IR and UV behaviours of this amplitude are known [8] and motivate a partition of

³ As usual, a null momentum is represented as a pair of two component spinors $p^\mu = \sigma_{\alpha\dot{\alpha}}^\mu \lambda^\alpha \bar{\lambda}^{\dot{\alpha}}$. For real momenta $\lambda = \pm \bar{\lambda}^*$ but for complex momenta λ and $\bar{\lambda}$ are independent [17]. We are using a spinor helicity formalism with the usual spinor products $\langle ab \rangle = \epsilon_{\alpha\beta} \lambda_a^\alpha \lambda_b^\beta$ and $[ab] = -\epsilon_{\dot{\alpha}\dot{\beta}} \bar{\lambda}_a^{\dot{\alpha}} \bar{\lambda}_b^{\dot{\beta}}$. Also $s_{ab} = (k_a + k_b)^2 = \langle ab \rangle [ba]$.

the amplitude:

$$A_n^{(2)}(1^+, 2^+, \dots, n^+) = A_n^{(1)}(1^+, 2^+, \dots, n^+) \left[- \sum_{i=1}^n \frac{1}{\epsilon^2} \left(\frac{\mu^2}{-s_{i,i+1}} \right)^\epsilon + \frac{n\pi^2}{12} \right] + F_n^{(2)} + \mathcal{O}(\epsilon). \quad (2.5)$$

In this equation $A_n^{(1)}$ is the all- ϵ form of the one-loop amplitude. The finite remainder function $F_n^{(2)}$ can be split into polylogarithmic and rational pieces,

$$F_n^{(2)} = P_n^{(2)} + R_n^{(2)}. \quad (2.6)$$

For this amplitude $P_n^{(2)}$ can be computed using four-dimensional cuts. The result for arbitrary n was calculated in [20] and for completeness we summarize the calculation in the following section. $R_n^{(2)}$ is a purely rational function whose structure is not captured by four-dimensional unitarity cuts. The result for $R_6^{(2)}$ was presented in [15]. Here the six-point example is used to present the methodology of the calculation. This methodology can be straightforwardly applied to the seven-point case and we present the result for $R_7^{(2)}$.

III. DETERMINING $P_n^{(2)}$

In this section we review the construction of the pieces of the amplitude which contribute to the IR singular terms and $P_n^{(2)}$. We are able to obtain these using four-dimensional unitarity methods. Noting that the one-loop amplitudes have no four dimensional cuts since the order ϵ^0 expression is purely rational, by using cuts where the momenta lie in four dimensions the one-loop all-plus amplitude appears as a rational vertex which cannot be further cut. Consequently the cuts of the two-loop amplitude manifest as cuts of one-loop integral functions which can be evaluated using essentially one-loop unitarity techniques. For completeness we review the n -point calculation presented in [20].

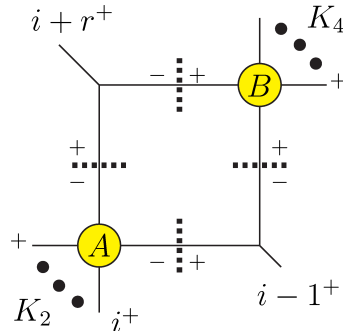

FIG. 1: The non-vanishing quadruple cut. A is a MHV tree amplitude whereas B is a one-loop all-plus amplitude. The set K_2 may consist of a single leg but the set K_4 must contain at least two legs. The integral function depends upon $S \equiv (k_{i-1} + K_2)^2$ and $T \equiv (K_2 + k_{i+r})^2$.

First consider quadruple cuts of the amplitude [21]: the only non-vanishing configuration is shown in fig. 1. As shown in [20], the coefficient of the one-loop box integral function I_4^{2m}

depicted in fig. 1 is

$$\frac{[i-1|K_4|i+r\rangle][i+r|K_4|i-1\rangle}{\langle 12\rangle\langle 23\rangle\langle 34\rangle\cdots\langle n1\rangle} \times \left(\sum_{a<b<c<d\in K_4} \text{tr}_-[abcd] - \sum_{a<b<c\in K_4} \text{tr}_-[abcK_4] + \sum_{a<b\in K_4} \frac{\langle i-1|K_4abK_4|i+r\rangle}{\langle i-1i+r\rangle} \right) \quad (3.1)$$

where

$$\text{tr}_-[abcd] \equiv \langle ab\rangle [bc] \langle cd\rangle [da] , \quad (3.2)$$

K_4 is the sum of the momenta in the set $\{i+r+1, \dots, i-2\}$ with a cyclic definition of indices and inequality refers to ordering within the set. The corresponding integral function satisfies

$$-2(ST - K_2^2 K_4^2) I_4^{2m} = \left(-\frac{(-S/\mu^2)^{-\epsilon}}{\epsilon^2} - \frac{(-T/\mu^2)^{-\epsilon}}{\epsilon^2} + \frac{(-K_2^2/\mu^2)^{-\epsilon}}{\epsilon^2} + \frac{(-K_4^2/\mu^2)^{-\epsilon}}{\epsilon^2} \right) + F^{2m}[S, T, K_2^2, K_4^2] \quad (3.3)$$

where

$$F^{2m}[S, T, K_2^2, K_4^2] = \text{Li}_2\left[1 - \frac{K_2^2}{S}\right] + \text{Li}_2\left[1 - \frac{K_2^2}{T}\right] + \text{Li}_2\left[1 - \frac{K_4^2}{S}\right] + \text{Li}_2\left[1 - \frac{K_4^2}{T}\right] - \text{Li}_2\left[1 - \frac{K_2^2 K_4^2}{ST}\right] + \text{Log}^2(S/T)/2 . \quad (3.4)$$

There are also contributions from one and two mass triangle integral functions. These can be determined using triple cuts (for example using canonical forms [22] or analytic structure [23]) and only contribute to the IR singularities. Overall [20],

$$\sum \mathcal{C}_i I_{4,i}^{2m} \Big|_{IR} + \sum \mathcal{C}_i I_{3,i}^{2m} + \sum \mathcal{C}_i I_{3,i}^{1m} = A_n^{(1),\epsilon^0}(1^+, 2^+, \dots, n^+) \times -\sum_{i=1}^n \frac{1}{\epsilon^2} \left(\frac{\mu^2}{-s_{i,i+1}} \right)^\epsilon , \quad (3.5)$$

where $A_n^{(1),\epsilon^0}(1^+, 2^+, \dots, n^+)$ is the order ϵ^0 truncation of the one-loop amplitude.

A key step is to promote the coefficient of these terms to the all- ϵ form of the one-loop amplitude. This ensures that the two-loop amplitude has the correct singular structure.

$P_n^{(2)}$ is obtained by summing over all possible box contributions, including the degenerate cases when K_2 corresponds to a single leg (K_4 must contain to at least two external legs). The full expression for $P_n^{(2)}$ is [20],

$$P_n^{(2)} = -\frac{i}{3\langle 12\rangle\langle 23\rangle\langle 34\rangle\cdots\langle n1\rangle} \sum_{i=1}^n \sum_{r=1}^{n-4} c_{r,i} F_{n,r,i}^{2m} \quad (3.6)$$

where the labels on the integral function correspond to those in fig. 1 and the coefficient is

$$c_{r,i} = \left(\sum_{a<b<c<d \in K_4} \text{tr}_-[abcd] - \sum_{a<b<c \in K_4} \text{tr}_-[abcK_4] + \sum_{a<b \in K_4} \frac{\langle i-1|K_4abK_4|i+r \rangle}{\langle i-1 \ i+r \rangle} \right) \quad (3.7)$$

IV. COMPLEX RECURSION

Britto-Cachazo-Feng-Witten recursion [5] exploits the analytic properties of a rational quantity, R , under a complex shift of its external momenta. R may be an n -point tree amplitude or part of a loop amplitude. The momentum shift introduces a complex parameter, z , whilst preserving overall momentum conservation and keeping all external momenta null.

Possible shifts include the original BCFW shift which acts on two momenta, say p_i and p_j , by

$$\bar{\lambda}_i \rightarrow \bar{\lambda}_{\hat{i}} = \bar{\lambda}_i - z\bar{\lambda}_j, \quad \lambda_j \rightarrow \lambda_{\hat{j}} = \lambda_j + z\lambda_i, \quad (4.1)$$

the all-line shift [24] and the Risager shift [25] which acts on three momenta, say p_i , p_j and p_k , by

$$\begin{aligned} \lambda_i &\rightarrow \lambda_{\hat{i}} = \lambda_i + z[jk]\lambda_\eta, \\ \lambda_j &\rightarrow \lambda_{\hat{j}} = \lambda_j + z[k i]\lambda_\eta, \\ \lambda_k &\rightarrow \lambda_{\hat{k}} = \lambda_k + z[i j]\lambda_\eta. \end{aligned} \quad (4.2)$$

In the last case λ_η must satisfy $\langle i \eta \rangle \neq 0$ etc., but is otherwise unconstrained.

After applying the shift, the rational quantity of interest is a complex function parametrized by z i.e. $R(z)$. Cauchy's theorem implies that:

$$\frac{1}{2\pi i} \oint \frac{R(z)}{z} = R(0) + \sum_{z_j \neq 0} \text{Res} \left[\frac{R(z)}{z} \right] \Big|_{z_j}, \quad (4.3)$$

where the contour is a circle taken towards infinity. If $R(z)$ vanishes in the large $|z|$ limit, the left hand side is zero and the unshifted quantity can be defined in its entirety by its singularities:

$$R = R(0) = - \sum_{z_j \neq 0} \text{Res} \left[\frac{R(z)}{z} \right] \Big|_{z_j}. \quad (4.4)$$

For the rational part of the two-loop all-plus amplitude the BCFW shift generates a shifted quantity that does not vanish at infinity and so cannot be used to reconstruct the amplitude (the one-loop all-plus amplitudes also behave in this way). However, using the Risager shift (4.2) does yield a shifted quantity with the desired asymptotic behaviour, so this is the shift employed.

Eq. (4.4) is true when $R(z)$ has either simple or higher order poles. In the case of a simple pole at $z = z_j$,

$$\text{Res} \left[\frac{R(z)}{z} \right] \Big|_{z_j} = \frac{1}{z_j} \text{Res} \left[R(z) \right] \Big|_{z_j} \quad (4.5)$$

and an understanding of the factorisations of $R(z)$ can be used to obtain the residue. For example, tree amplitudes have simple poles when a shifted propagator vanishes and the

corresponding residues are readily obtained from general factorisation theorems leading to the BCFW recursion formulae for tree amplitudes [5].

Loop amplitudes in non-supersymmetric theories may have double poles. Mathematically this is not a problem since if we consider a function with a double pole at $z = z_j$ and Laurent expansion,

$$R(z) = \frac{c_{-2}}{(z - z_j)^2} + \frac{c_{-1}}{(z - z_j)} + \mathcal{O}((z - z_j)^0), \quad (4.6)$$

then the required residue is

$$\text{Res}\left[\frac{R(z)}{z}\right]\Big|_{z_j} = -\frac{c_{-2}}{z_j^2} + \frac{c_{-1}}{z_j} \quad (4.7)$$

and we can use Cauchy's theorem *provided* we know the value of both the leading and sub-leading poles. When applying this to an amplitude, the leading pole can be obtained from factorisation theorems, but, at this point, there are no general theorems determining the sub-leading pole. Consequently we need to determine the sub-leading pole for each specific case. We do this by identifying the singularities within a specific computational scheme, we choose to use axial gauge. We have used this approach previously to compute one-loop which contain double poles [26–28]. We label this process *augmented recursion* and describe it in later sections.

V. FACTORISATIONS OF $R_n^{(2)}$

To apply the methods of the previous section we must discuss the factorisations and resultant residues of $R_n^{(2)}$.

Note that $P_n^{(2)}$ does not contain any unphysical poles and so the factorisations of $R_n^{(2)}$ are the physical factorisations of the amplitude. Explicitly these are

$$A_m^{(1)}(a^+, \dots, b^+, \hat{K}^\pm) \frac{1}{K_{a,b}^2} A_{n+2-m}^{(1)}(-\hat{K}^\mp, b+1^+, \dots, a-1^+) \quad (5.1)$$

with $3 \leq m \leq n-1$ and

$$R_{n-1}^{(2)}(a+2^+, \dots, a-1^+, \hat{K}^+) \frac{1}{s_{aa+1}} A_3^{(0)}(a^+, a+1^+, -\hat{K}^-) \quad (5.2)$$

where the particular one-loop amplitudes $A_r^{(1)}$ in the factorisation are purely rational functions.

Many factorisations of loop amplitudes involve only simple poles and the corresponding residues can be determined using general factorisation theorems. However certain factorisations introduce double poles which are sensitive to sub-leading information that is not captured by the general theorems.

The origin of these terms is shown in fig. 2 where there is an explicit pole from the highlighted propagator and a further pole from the 3-pt loop integral.

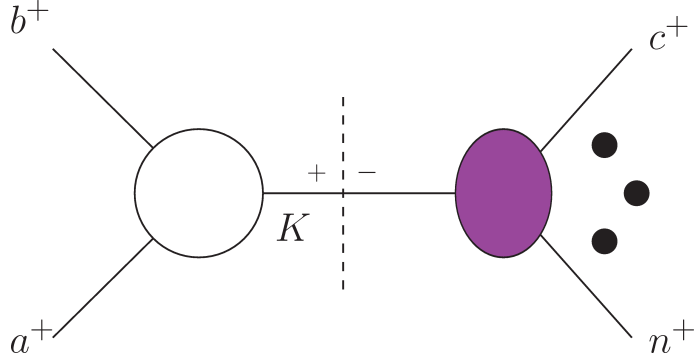

FIG. 2: The origin of the double pole. The double pole corresponds to the coincidence of the singularity arising in the 3-pt integral with the factorisation corresponding to $K^2 = s_{ab} \rightarrow 0$.

VI. AUGMENTED RECURSION

To analyse the s_{ab} double pole we use axial gauge methods. The advantage of axial gauge is that, although it is an off-shell method, helicity still labels the internal legs and the vertices can be expressed in terms of *nullified momenta* [29, 30] defined using,

$$K^b = K - \frac{K^2}{[q|K|q]}q \quad (6.1)$$

where q is a reference vector.

In this formalism the 3-pt loop integral can be expressed as,

$$V_3^{(1)}(a^+, b^+, K^+) = \frac{i}{3} \frac{[a b] [b K^b] [K^b a]}{K^2} \quad (6.2)$$

which is only non-zero for complex momenta. The pole as $K^2 \rightarrow 0$ arises from regions of the loop momentum integration where three adjacent propagators are simultaneously on-shell. The full contribution arises from structures of the form shown in fig. 3 which contain both single and double poles.

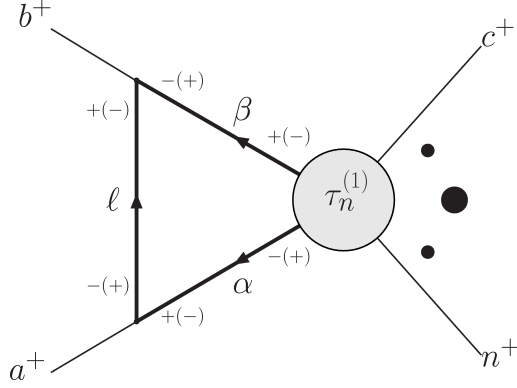

FIG. 3: Diagram containing the leading and sub-leading poles as $s_{ab} \rightarrow 0$. The axial gauge construction permits the off-shell continuation of the internal legs. The two internal helicity configurations must be summed over to obtain the complete contribution to the $1/s_{ab}$ residue. The one-loop current $\tau_n^{(1)}$ can be built from the on-shell n -point one-loop single minus amplitude.

Expressing the 3-pt vertices in axial gauge, the principal helicity assignment in fig. 3 gives the integral

$$\frac{i}{(2\pi)^D} \int \frac{d^D \ell}{\ell^2 \alpha^2 \beta^2} \frac{[a|\ell|q][b|\ell|q] \langle \beta q \rangle^2}{\langle a q \rangle \langle b q \rangle \langle \alpha q \rangle^2} \tau_n^{(1)}(\alpha^-, \beta^+, c^+, \dots, n^+). \quad (6.3)$$

To determine (6.3) in general we would need to consider ℓ , α and β to be off-shell and $\tau_n^{(1)}$ to be the doubly off-shell one-loop current. However, as we are only interested in the residue on the $s_{ab} \rightarrow 0$ pole, we do not need the full current. Instead it is sufficient for $\tau_n^{(1)}$ to satisfy two conditions [28]:

- I** it reproduces the leading poles in $s_{\alpha\beta} \rightarrow 0$ shown in fig. 4.
- II** in the limit $\alpha^2, \beta^2 \rightarrow 0$ (the on-shell limit) the n -point one-loop single minus amplitude is reproduced.

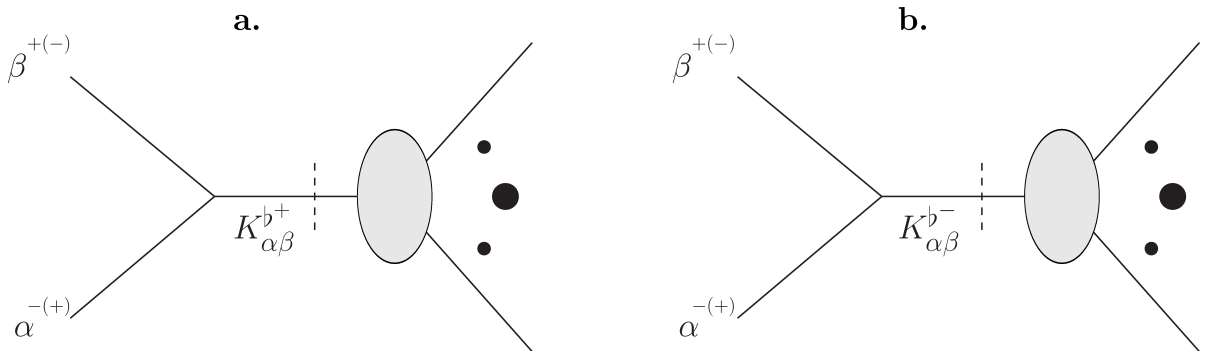

FIG. 4: The factorisations that $\tau_n^{(1)}$ must reproduce.

In manipulating $\tau_n^{(1)}$ we can neglect terms which are ultimately finite as $\langle ab \rangle \rightarrow 0$ and hence do not contribute to the residue. As any powers of ℓ^2 , α^2 or β^2 appearing in the numerator generate powers of s_{ab} when the loop momentum integration is performed, α^2 and β^2 are also regarded as small in these manipulations. Similarly $\langle a\alpha \rangle$, $\langle a\beta \rangle$, $\langle b\alpha \rangle$ and $\langle b\beta \rangle$ can all be regarded as small.

Condition **II** provides a starting point for constructing the current as detailed in appendix A.

VII. THE s_{ab} POLE IN THE SIX-POINT RATIONAL TERM

In this section we determine the leading and sub-leading poles in $R_6^{(2)}$ as $s_{ab} \rightarrow 0$. Our starting point is the on-shell six-point single minus amplitude organised as in appendix A:

$$A_6^{(1)}(\alpha^-, \beta^+, c^+, d^+, e^+, f^+) = \tau_6^{\text{d.p.}} + \tau_6^{\text{s.b.}} + \tau_6^{\text{n.f.}} + \mathcal{O}(\langle \alpha\beta \rangle) \quad (7.1)$$

which we simply take off-shell by replacing α and β by their nullified form within axial gauge. With this organisation it is natural to write

$$\frac{i}{c_\Gamma(2\pi)^D} \int \frac{d^D \ell}{\ell^2 \alpha^2 \beta^2} \frac{[a|\ell|q][b|\ell|q] \langle \beta q \rangle^2}{\langle aq \rangle \langle bq \rangle \langle \alpha q \rangle^2} \tau_6^{(1)}(\alpha^-, \beta^+, c^+, d^+, e^+, f^+) = \mathcal{I}_{\text{d.p.}}^{\alpha-\beta+} + \mathcal{I}_{\text{s.b.}}^{\alpha-\beta+} + \mathcal{I}_{\text{n.f.}}^{\alpha-\beta+}. \quad (7.2)$$

The double poles arise from

$$\begin{aligned} \mathcal{I}_{\text{d.p.}}^{\alpha-\beta+} \equiv & \frac{i}{3} \int d\Lambda_{ab}^{\alpha\beta} \left[\frac{\langle q|\alpha\beta|q \rangle [q|K_{ab}|q]}{s_{ab} [q|K_{ab}|c] \langle de \rangle^2} \left(- \frac{[fc]^3}{t_{abc} [f|K_{ab}|c]} \frac{[q|K_{ab}|c]^3}{[q|K_{ab}|q]^3} \right. \right. \\ & \left. \left. + \frac{[ef] \langle df \rangle}{\langle cd \rangle \langle ef \rangle^2} \frac{[q|K_{ab}|e]^3}{[q|K_{ab}|q]^3} - \frac{\langle ce \rangle [dc]}{\langle cd \rangle^2 \langle ef \rangle} \frac{[q|K_{ab}|d]^3}{[q|K_{ab}|q]^3} \frac{[q|K_{ab}|c]}{[q|K_{ab}|f]} \right) \right] \quad (7.3) \end{aligned}$$

where⁴

$$\int d\Lambda_{ab}^{\alpha\beta} \equiv \frac{i}{c_\Gamma(2\pi)^D} \int \frac{d^D \ell}{\ell^2 \alpha^2 \beta^2} \frac{[a|\ell|q][b|\ell|q]}{\langle aq \rangle \langle bq \rangle}. \quad (7.4)$$

The integral corresponding to the square bracket pole in the current is,

$$\begin{aligned} \mathcal{I}_{\text{s.b.}}^{\alpha-\beta+} = & \frac{i}{3} \int d\Lambda_{ab}^{\alpha\beta} \left[\frac{[q|\beta|q]^2 [q|\alpha\beta|q]}{[q|\alpha|q]^2 [q|K_{ab}|q]^2} \frac{1}{s_{ab}} \frac{[f|K_{ab}|q]^2}{t_{cde}} \left(\frac{\langle q|K_{ab}|c \rangle [cd]}{\langle de \rangle \langle q|K_{ab}K_{cd}|e \rangle} \right. \right. \\ & \left. \left. - \frac{[de][ef]}{\langle cd \rangle [f|k|c]} + \frac{[ce]}{\langle cd \rangle \langle de \rangle} \right) \right]. \quad (7.5) \end{aligned}$$

⁴ The factor c_Γ is inserted to make the normalisation consistent with eq. 2.1.

The remaining function constitutes the sub-leading non-factorising parts:

$$\mathcal{I}_{\text{n.f.}}^{\alpha-\beta+} = \int d\Lambda_{ab}^{\alpha\beta} \left[\frac{\langle\beta q\rangle^2}{\langle\alpha q\rangle^2} \times \tau_6^{\text{n.f.}} \right] , \quad (7.6)$$

where $\tau_6^{\text{n.f.}}$ is the expression defined in (A24).

These expressions may be integrated to obtain the contribution from fig. 3 (up to terms that are finite as $s_{ab} \rightarrow 0$). The explicit integrations may be found in appendix B. The results are⁵

$$\begin{aligned} \mathcal{I}_{\text{d.p.}}^{\alpha-\beta+} \Big|_{\mathbb{Q}} = & -\frac{i}{18} \frac{[ab]}{\langle ab \rangle} \frac{\langle q|ab|q\rangle \langle q|K_{ab}|q\rangle}{s_{ab} \langle q|K_{ab}|c\rangle \langle de\rangle^2} \left(-\frac{[fc]^3}{t_{abc} [f|K_{ab}|c]} \frac{[q|K_{ab}|c]^3}{[q|K_{ab}|q]^3} \right. \\ & \left. + \frac{[ef] \langle df \rangle}{\langle cd \rangle \langle ef \rangle^2} \frac{[q|K_{ab}|e]^3}{[q|K_{ab}|q]^3} - \frac{\langle ce \rangle [dc]}{\langle cd \rangle^2 \langle ef \rangle} \frac{[q|K_{ab}|d]^3 [q|K_{ab}|c]}{[q|K_{ab}|q]^3 [q|K_{ab}|f]} \right) . \end{aligned} \quad (7.7)$$

The expression for $\mathcal{I}_{\text{n.f.}}^{\alpha-\beta+}$ is quite complicated and is given in (B20). The full s_{ab} contribution requires the other helicity configuration in fig. 3 whose contribution can be deduced by the application of symmetry principles to $\mathcal{I}^{\alpha-\beta+}$ after integration as detailed in appendix B.

For $\mathcal{I}_{\text{s.b.}}^{\alpha\beta}$, however, there are useful cancellations between the two helicity choices for α and β before integration. Defining $\mathcal{I} = \mathcal{I}^{\alpha-\beta+} + \mathcal{I}^{\alpha+\beta-}$, the full contribution from the square bracket factorisation is

$$\mathcal{I}_{\text{s.b.}} \Big|_{\mathbb{Q}} = \frac{i}{9} \frac{[qa][qb]}{\langle ab \rangle} \frac{[f|K_{ab}|q]^2}{[q|K_{ab}|q]^2 t_{cde}} \left(\frac{\langle q|K_{ab}|c\rangle [cd]}{\langle de \rangle \langle q|K_{ab}|K_{cd}|e\rangle} - \frac{[de][ef]}{\langle cd \rangle [f|k|c]} + \frac{[ce]}{\langle cd \rangle \langle de \rangle} \right) . \quad (7.8)$$

We can now compute $R_6^{(2)}$ by recursion.

VIII. $R_6^{(2)}$

As discussed above, the BCFW shift does not vanish at infinity and so cannot be used to generate the result. At five-point this can be seen by applying the shift to the known result, while at six- and seven-point it can be seen retrospectively by applying the shift to the results we obtain. However the Risager shift does vanish at infinity for the five-point amplitude and results in rational terms with the correct symmetries and factorisations for both the six- and seven-point amplitudes. This self-consistency provides a stringent check of the result.

Applying the Risager shift to three adjacent legs, a , b and c of $R_6^{(2)}(a, b, c, d, e, f)$ and identifying λ_η with the axial gauge spinor λ_q ⁶, factorisations arise with both single and

⁵ The restriction $|_{\mathbb{Q}}$ means only the finite rational functions of the spinor variables are kept.

⁶ Setting $\lambda_\eta = \lambda_q$ prevents the shift from exciting spurious poles such as $\langle \hat{a}q \rangle \rightarrow 0$.

double poles. Those involving only simple poles are

$$\begin{aligned} & \sum_{\lambda=\pm} A_4^{(1)}(e, f, \hat{a}^+, \hat{K}^\lambda) \frac{1}{K^2} A_4^{(1)}(-\hat{K}^{-\lambda}, \hat{b}, \hat{c}, d), \\ & \sum_{\lambda=\pm} A_4^{(1)}(f, \hat{a}, \hat{b}, \hat{K}^\lambda) \frac{1}{K^2} A_4^{(1)}(-\hat{K}^{-\lambda}, \hat{c}, d, e) \end{aligned} \quad (8.1)$$

and

$$\begin{aligned} & A_3^{\text{tree}}(\hat{a}, \hat{b}, \hat{K}^-) \frac{1}{K^2} R_5^{(2)}(-\hat{K}^+, \hat{c}, d, e, f), \\ & A_3^{\text{tree}}(f, \hat{a}, \hat{K}^-) \frac{1}{K^2} R_5^{(2)}(-\hat{K}^+, \hat{b}, \hat{c}, d, e), \\ & R_5^{2\text{-loop}}(-\hat{K}^+, e, f, \hat{a}, \hat{b}) \frac{1}{K^2} A_3^{\text{tree}}(\hat{c}, d, \hat{K}^-), \\ & R_5^{(2)}(-\hat{K}^+, d, e, f, \hat{a}) \frac{1}{K^2} A_3^{\text{tree}}(\hat{b}, \hat{c}, \hat{K}^-), \end{aligned} \quad (8.2)$$

whose residues can simply be evaluated at the appropriate complex pole. The remaining factorisations:

$$\begin{aligned} & V_3^{(1)}(f^+, \hat{a}^+, \hat{K}^+) \frac{1}{K^2} A_5^{(1)}(-\hat{K}^-, \hat{b}^+, \hat{c}^+, d, e), \\ & V_3^{(1)}(\hat{c}^+, d^+, \hat{K}^+) \frac{1}{K^2} A_5^{(1)}(-\hat{K}^-, e, f, \hat{a}^+, \hat{b}^+), \\ & V_3^{(1)}(\hat{a}, \hat{b}, \hat{K}^\lambda) \frac{1}{K^2} A_5^{(1)}(-\hat{K}^{-\lambda}, \hat{c}^+, d, e, f), \\ & V_3^{(1)}(\hat{b}, \hat{c}, \hat{K}^\lambda) \frac{1}{K^2} A_5^{(1)}(-\hat{K}^{-\lambda}, d, e, f, \hat{a}^+), \end{aligned} \quad (8.3)$$

have double poles as determined in the previous section.

Summing the corresponding residues gives an expression which involves λ_η and, due to the choice of shifted legs, cyclic symmetry is not manifest. However, the result is independent of λ_η and has full cyclic and flip symmetry. By construction $R_6^{(2)}$ has the correct factorisations in all of the channels excited by the shift. Combining this with the cyclic symmetry ensures that it has the correct factorisations in all channels. In the following section we present a compact analytic form for $R_6^{(2)}$ that is manifestly independent of the shift and axial gauge vectors and has manifest cyclic symmetry.

IX. FINAL $R_6^{(2)}$ ANALYTIC FORM

We can obtain a form for $R_6^{(2)}$ that is explicitly independent of q , has manifest cyclic symmetry and no spurious poles. To obtain this form for $R_6^{(2)}$ the form generated by recursion

first has the factorising residues extracted:

$$R_6^{\text{fact}} = \frac{i}{9} \frac{1}{\langle 12 \rangle \langle 23 \rangle \langle 34 \rangle \langle 45 \rangle \langle 56 \rangle \langle 61 \rangle} (G_6^1 + G_6^2 + G_6^3 + G_6^4) \quad (9.1)$$

where

$$\begin{aligned} G_6^1 &= \frac{s_{cd}s_{df}\langle f|aK_{abc}|e\rangle}{\langle fe\rangle t_{abc}} + \frac{s_{ac}s_{dc}\langle a|fK_{def}|b\rangle}{\langle ab\rangle t_{def}}, \\ G_6^2 &= \frac{[ab][fe]}{\langle ab\rangle\langle fe\rangle} \langle ae\rangle^2 \langle fb\rangle^2 + \frac{1}{2} \frac{[af][cd]}{\langle af\rangle\langle cd\rangle} \langle ac\rangle^2 \langle df\rangle^2, \\ G_6^3 &= \frac{s_{df}\langle af\rangle\langle cd\rangle[ca][df]}{t_{abc}} \end{aligned} \quad (9.2)$$

and

$$G_6^4 = \frac{\langle a|be|f\rangle t_{def}}{\langle af\rangle}. \quad (9.3)$$

Then the remainder of the function is fitted:

$$\begin{aligned} G_6^5 &= 2s_{ac}^2 + s_{eb}^2 + s_{ab}(-3s_{ac} - 2s_{ad} + 6s_{ae} + 4s_{bc} + s_{bd} + 2s_{be} + 4s_{bf} + 7s_{cd} - s_{ce} - s_{de} + 3s_{df}) \\ &\quad + s_{ac} \left(2s_{ad} + 3s_{ae} - 2s_{bd} - s_{be} + s_{cf} - \frac{5}{2}s_{df} \right) + \frac{3}{2}s_{ad}s_{be} \\ &\quad - 8\langle bc\rangle[cd]\langle de\rangle[eb] + 5\langle fa\rangle[ac]\langle cd\rangle[df], \end{aligned}$$

leading to the final expression

$$R_6^{(2)} = \frac{i}{9} \sum_{\text{cyclic perms}} \frac{G_6^1 + G_6^2 + G_6^3 + G_6^4 + G_6^5}{\langle 12 \rangle \langle 23 \rangle \langle 34 \rangle \langle 45 \rangle \langle 56 \rangle \langle 61 \rangle}. \quad (9.4)$$

This was confirmed in an independent calculation [31]. This is a simpler form than that of [15]: it has been reformulated to be manifestly free of spurious singularities.

X. THE SEVEN-POINT RATIONAL PIECE

The seven-point rational piece can be calculated in an identical fashion. The seven-point current $\tau_7^{(1)}(\alpha^-, \beta^+, c^+, d^+, e^+, f^+, g^+)$ is built from the corresponding seven-point single minus amplitude [32] just as the six-point current was built from the six-point amplitude. $R_6^{(2)}$

as determined above is also required for recursion. Defining

$$\begin{aligned}
G_7^1 &= \frac{\langle ga \rangle}{t_{abc}t_{efg}} \left(\frac{\langle cd \rangle [eg] [d|K_{abc}|e] [a|K_{abc}|e] [c|K_{abc}|f]}{\langle ef \rangle} - \frac{\langle de \rangle [ca] [d|K_{efg}|c] [g|K_{efg}|c] [e|K_{efg}|b]}{\langle bc \rangle} \right. \\
&\quad \left. + \frac{\langle ef \rangle \langle cd \rangle [ca] [fg] [e|K_{efg}|a] [d|K_{efg}|b]}{\langle ab \rangle} - \frac{\langle bc \rangle \langle de \rangle [eg] [ab] [c|K_{abc}|g] [d|K_{abc}|f]}{\langle fg \rangle} \right), \\
G_7^2 &= \frac{1}{t_{abc}t_{efg}} s_{cd}s_{de} \langle ga \rangle [g|K_{efg}K_{abc}|a], \\
G_7^3 &= \frac{1}{t_{cde}} \left(s_{ce} \left(\frac{s_{ef} \langle c|K_{ab}K_{fga}|d \rangle}{\langle cd \rangle} - \frac{s_{bc} \langle e|K_{fg}K_{gab}|d \rangle}{\langle de \rangle} \right) + \frac{\langle ef \rangle \langle bc \rangle [fb] [c|K_{cde}|g] [e|K_{cde}|a]}{\langle ga \rangle} \right. \\
&\quad \left. + \frac{\langle bc \rangle [c|K_{cde}|b] [e|K_{cde}|a] [b|K_{fg}|e]}{\langle ab \rangle} + \frac{\langle ef \rangle [e|K_{cde}|f] [c|K_{cde}|g] [f|K_{ab}|c]}{\langle fg \rangle} \right), \\
G_7^4 &= \frac{[ga]}{\langle ga \rangle} \langle ge \rangle \langle ae \rangle \left(\frac{[de]}{\langle de \rangle} \langle dg \rangle \langle da \rangle + \frac{[ef]}{\langle ef \rangle} \langle fg \rangle \langle fa \rangle \right), \\
G_7^5 &= \frac{1}{t_{cde}} (\langle ce \rangle (\langle ef \rangle [df] \langle c|K_{ab}K_{fga}|d \rangle + \langle bc \rangle [db] \langle e|K_{fg}K_{gab}|d \rangle) \\
&\quad + \langle bc \rangle \langle ef \rangle (2 \langle ga \rangle [ce] [fg] [ab] + [bf] [e|K_{ab}K_{fg}|c])), \\
G_7^6 &= \frac{1}{\langle ga \rangle} (\langle g|fK_{bc}|a \rangle t_{efg} - \langle a|bK_{ef}|g \rangle t_{abc}) \tag{10.1}
\end{aligned}$$

and

$$\begin{aligned}
G_7^7 &= s_{bf}^2 - 2s_{ga}^2 - 3s_{db}s_{df} + 4s_{da}s_{dg} - 6s_{ac}s_{eg} + 7(s_{eb}s_{fc} + s_{ea}s_{gc}) + s_{ab}s_{fg} + 3s_{fa}s_{gb} \\
&\quad + s_{ce}(s_{cf} + s_{eb} - 4(s_{ab} + s_{fg} + s_{ga})) + 5[d|K_{ga}|d] \\
&\quad + 4[e|bcf|e] - 2[f|gab|f] + 3[g|baf|g] + 2[g|cea|g], \tag{10.2}
\end{aligned}$$

the full function in this case is

$$R_7^{(2)} = \frac{i}{9} \sum_{\text{cyclic perms}} \frac{G_7^1 + G_7^2 + G_7^3 + G_7^4 + G_7^5 + G_7^6 + G_7^7}{\langle 12 \rangle \langle 23 \rangle \langle 34 \rangle \langle 45 \rangle \langle 56 \rangle \langle 67 \rangle \langle 71 \rangle}. \tag{10.3}$$

This expression has the full cyclic and flip symmetries required and has all the correct factorisations and collinear limits. It been generated under the assumption that the shifted rational function vanishes at infinity: if this had been unjustified we would not have generated a function with the appropriate symmetries. This completes the seven-point calculation.

XI. CONCLUSION

In this article we have detailed the construction of the all-plus leading in colour two-loop gluon scattering amplitude and presented the results for the six- and seven-point cases in straightforward analytic expressions. Our methods are based upon an understanding of the singular structure an on-shell amplitude satisfies and in particular we have only needed four-dimensional unitarity methods. These techniques, at present, are not completely rigorous

but the amplitudes generated satisfy a range of stringent consistency checks. We have largely used on-shell methods but have had to augment these with some off-shell information. General theorems for the factorisation of loop amplitudes on complex momenta which specified the sub-leading behaviour would simplify further the process and avoid integrations.

This particular helicity configuration remains the only two-loop amplitude calculated beyond four point. Extending analytic results to the other helicity amplitudes is clearly necessary for phenomenology and we hope the methods here will be fruitful in this.

XII. ACKNOWLEDGEMENTS

This work was supported by STFC grant ST/L000369/1. GRJ was supported by STFC grant ST/M503848/1. JHG was supported by the College of Science (CoS) Doctoral Training Centre (DTC) at Swansea University

Appendix A: The six-point one-loop single minus amplitude

The six-point single minus one-loop amplitude is [32]:

$$\begin{aligned}
A_6^{(1)}(\alpha^-, \beta^+, c^+, d^+, e^+, f^+) &= \frac{i}{3} \left[\frac{[f|K_{\beta c}|\alpha]^3}{\langle \alpha \beta \rangle \langle \beta c \rangle \langle d e \rangle^2 t_{\alpha \beta c} [f|K_{\alpha \beta}|c]} + \frac{[\beta|K_{cd}|\alpha]^3}{\langle c d \rangle^2 \langle e f \rangle \langle f \alpha \rangle t_{\beta c d} [\beta|K_{cd}|e]} \right. \\
&+ \frac{[\beta f]^3}{[\alpha \beta][f \alpha] t_{cde}} \left(\frac{[\beta c][cd]}{\langle d e \rangle [\beta|K_{cd}|e]} - \frac{[de][ef]}{\langle c d \rangle [f|K_{\alpha \beta}|c]} + \frac{[ce]}{\langle c d \rangle \langle d e \rangle} \right) \\
&- \frac{\langle \alpha c \rangle^3 [\beta c] \langle \beta d \rangle}{\langle \beta c \rangle^2 \langle c d \rangle^2 \langle d e \rangle \langle e f \rangle \langle f \alpha \rangle} + \frac{\langle \alpha e \rangle^3 [ef] \langle d f \rangle}{\langle \alpha \beta \rangle \langle \beta c \rangle \langle c d \rangle \langle d e \rangle^2 \langle e f \rangle^2} \\
&\left. - \frac{\langle \alpha d \rangle^3 \langle c e \rangle [d|K_{\beta c}|\alpha]}{\langle \alpha \beta \rangle \langle \beta c \rangle \langle c d \rangle^2 \langle d e \rangle^2 \langle e f \rangle \langle f \alpha \rangle} \right]. \tag{A1}
\end{aligned}$$

We manipulate the amplitude into a form where taking the off-shell continuation exactly reproduces the factorisations shown in fig.4, thus satisfying condition **I**. As the starting point is the six-point amplitude, condition **II** is automatically encoded. First we collect terms with $\langle \alpha \beta \rangle$ and $[\alpha \beta]$ in the denominator as these contribute to the factorisations.

$$\begin{aligned}
A_6^{(1)}(\alpha^-, \beta^+, c^+, d^+, e^+, f^+) &= \frac{i}{3} \left[\frac{1}{\langle \alpha \beta \rangle \langle \beta c \rangle \langle d e \rangle^2} \left(\frac{[f|K_{\beta c}|\alpha]^3}{t_{\alpha \beta c} [f|K_{\alpha \beta}|c]} + \frac{\langle \alpha e \rangle^3 [ef] \langle d f \rangle}{\langle c d \rangle \langle e f \rangle^2} - \frac{\langle \alpha d \rangle^3 \langle c e \rangle [d|K_{\beta c}|\alpha]}{\langle c d \rangle^2 \langle e f \rangle \langle f \alpha \rangle} \right) \right. \\
&+ \frac{[\beta f]^3}{[\alpha \beta][f \alpha] t_{cde}} \left(\frac{[\beta c][cd]}{\langle d e \rangle [\beta|K_{cd}|e]} - \frac{[de][ef]}{\langle c d \rangle [f|K_{\alpha \beta}|c]} + \frac{[ce]}{\langle c d \rangle \langle d e \rangle} \right) \\
&\left. + \frac{[\beta|K_{cd}|\alpha]^3}{\langle c d \rangle^2 \langle e f \rangle \langle f \alpha \rangle t_{\beta c d} [\beta|K_{cd}|e]} - \frac{\langle \alpha c \rangle^3 [\beta c] \langle \beta d \rangle}{\langle \beta c \rangle^2 \langle c d \rangle^2 \langle d e \rangle \langle e f \rangle \langle f \alpha \rangle} \right] \tag{A2}
\end{aligned}$$

Expanding in $\langle \alpha \beta \rangle$ to isolate the singular pieces we find

$$\begin{aligned}
& A_6^{(1)}(\alpha^-, \beta^+, c^+, d^+, e^+, f^+) \\
&= \frac{i}{3} \left[\frac{1}{\langle \alpha \beta \rangle \langle \beta c \rangle \langle d e \rangle^2} \left(\frac{[f c]^3 \langle c \alpha \rangle^3}{t_{\alpha \beta c} [f | K_{\alpha \beta} | c]} + \frac{\langle \alpha e \rangle^3 [e f] \langle d f \rangle}{\langle c d \rangle \langle e f \rangle^2} - \frac{\langle \alpha d \rangle^3 \langle c e \rangle [d c] \langle c \alpha \rangle}{\langle c d \rangle^2 \langle e f \rangle \langle f \alpha \rangle} \right) \right. \\
&+ \frac{1}{\langle \beta c \rangle \langle d e \rangle^2} \left(\frac{[\beta f] (3[f | c | \alpha]^2 + 3[f | c | \alpha] [f | \beta | \alpha] + [f | \beta | \alpha]^2)}{t_{\alpha \beta c} [f | K_{\alpha \beta} | c]} - \frac{\langle \alpha d \rangle^3 \langle c e \rangle [\beta d]}{\langle c d \rangle^2 \langle e f \rangle \langle f \alpha \rangle} \right) \\
&+ \frac{[\beta f]^3}{[\alpha \beta] [f \alpha] t_{c d e}} \left(\frac{[\beta c] [c d]}{\langle d e \rangle [\beta | K_{c d} | e]} - \frac{[d e] [e f]}{\langle c d \rangle [f | K_{\alpha \beta} | c]} + \frac{[c e]}{\langle c d \rangle \langle d e \rangle} \right) \\
&\left. + \frac{[\beta | K_{c d} | \alpha]^3}{\langle c d \rangle^2 \langle e f \rangle \langle f \alpha \rangle t_{\beta c d} [\beta | K_{c d} | e]} - \frac{\langle \alpha c \rangle^3 [\beta c] \langle \beta d \rangle}{\langle \beta c \rangle^2 \langle c d \rangle^2 \langle d e \rangle \langle e f \rangle \langle f \alpha \rangle} \right]. \tag{A3}
\end{aligned}$$

The first line of eq. (A3) has the $\langle \alpha \beta \rangle^{-1}$ factor. This can be rewritten using

$$\begin{aligned}
\frac{1}{\langle \alpha \beta \rangle \langle \beta c \rangle} &= \frac{[\beta \alpha] [q | K_{\alpha \beta} | c] \langle \beta q \rangle}{s_{\alpha \beta} \langle \beta c \rangle \langle \beta q \rangle [q | K_{\alpha \beta} | c]} = \frac{[\beta \alpha] ([q | K_{\alpha \beta} | q] \langle \beta c \rangle + [q | K_{\alpha \beta} | \beta] \langle c q \rangle)}{s_{\alpha \beta} \langle \beta c \rangle \langle \beta q \rangle [q | K_{\alpha \beta} | c]} \\
&= \frac{1}{\langle \alpha q \rangle \langle \beta q \rangle^2} \left(\frac{\langle q | \alpha \beta | q \rangle [q | K_{\alpha \beta} | q]}{s_{\alpha \beta} [q | K_{\alpha \beta} | c]} + \frac{\langle q \beta \rangle \langle q c \rangle [q | \alpha | q]}{\langle \beta c \rangle [q | K_{\alpha \beta} | c]} \right) \tag{A4}
\end{aligned}$$

which is an algebraic identity for any q , but we specifically identify q with the axial gauge reference momenta. Applying the formula to (A3):

$$\begin{aligned}
& A_6^{(1)}(\alpha^-, \beta^+, c^+, d^+, e^+, f^+) = \\
& \frac{i}{3} \left[\frac{\langle q | \alpha \beta | q \rangle [q | K_{\alpha \beta} | q]}{s_{\alpha \beta} [q | K_{\alpha \beta} | c] \langle \alpha q \rangle \langle \beta q \rangle^2 \langle d e \rangle^2} \left(\frac{[f c]^3 \langle c \alpha \rangle^3}{t_{\alpha \beta c} [f | K_{\alpha \beta} | c]} + \frac{\langle \alpha e \rangle^3 [e f] \langle d f \rangle}{\langle c d \rangle \langle e f \rangle^2} - \frac{\langle \alpha d \rangle^3 \langle c e \rangle [d c] \langle c \alpha \rangle}{\langle c d \rangle^2 \langle e f \rangle \langle f \alpha \rangle} \right) \right. \\
&+ \frac{\langle c q \rangle [q | \alpha | q]}{\langle \beta c \rangle [q | K_{\alpha \beta} | c] \langle \alpha q \rangle \langle \beta q \rangle \langle d e \rangle^2} \left(\frac{[f c]^3 \langle c \alpha \rangle^3}{t_{\alpha \beta c} [f | K_{\alpha \beta} | c]} + \frac{\langle \alpha e \rangle^3 [e f] \langle d f \rangle}{\langle c d \rangle \langle e f \rangle^2} - \frac{\langle \alpha d \rangle^3 \langle c e \rangle [d c] \langle c \alpha \rangle}{\langle c d \rangle^2 \langle e f \rangle \langle f \alpha \rangle} \right) \\
&+ \frac{1}{\langle \beta c \rangle \langle d e \rangle^2} \left(\frac{3[\beta f] [f | c | \alpha]^2}{t_{\alpha \beta c} [f | K_{\alpha \beta} | c]} - \frac{\langle \alpha d \rangle^3 \langle c e \rangle [\beta d]}{\langle c d \rangle^2 \langle e f \rangle \langle f \alpha \rangle} \right) \\
&+ \frac{[\beta f]^3}{[\alpha \beta] [f \alpha] t_{c d e}} \left(\frac{[\beta c] [c d]}{\langle d e \rangle [\beta | K_{c d} | e]} - \frac{[d e] [e f]}{\langle c d \rangle [f | K_{\alpha \beta} | c]} + \frac{[c e]}{\langle c d \rangle \langle d e \rangle} \right) \\
&\left. + \frac{[\beta | K_{c d} | \alpha]^3}{\langle c d \rangle^2 \langle e f \rangle \langle f \alpha \rangle t_{\beta c d} [\beta | K_{c d} | e]} - \frac{\langle \alpha c \rangle^3 [\beta c] \langle \beta d \rangle}{\langle \beta c \rangle^2 \langle c d \rangle^2 \langle d e \rangle \langle e f \rangle \langle f \alpha \rangle} + \mathcal{O}(\langle \alpha \beta \rangle) \right]. \tag{A5}
\end{aligned}$$

The prefactor in the first line of (A5) encodes the three-point vertex in diagram 4a and the five-point single minus amplitude on the right can be reconstructed using

$$\frac{[\beta | K_{\alpha \beta} | X]}{[\beta | K_{\alpha \beta} | Y]} = \frac{[q | K_{\alpha \beta} | X]}{[q | K_{\alpha \beta} | Y]} + s_{\alpha \beta} \frac{\langle Y X \rangle [\beta q]}{[\beta | K_{\alpha \beta} | Y] [q | K_{\alpha \beta} | Y]} + \mathcal{O}(s_{\alpha \beta}^2), \tag{A6}$$

applied to the remainder of the first line:

$$\begin{aligned}
& \frac{1}{\langle \alpha q \rangle} \left(\frac{[fc]^3 \langle c\alpha \rangle^3}{t_{\alpha\beta c} [f|K_{\alpha\beta}|c]} + \frac{\langle \alpha e \rangle^3 [ef] \langle df \rangle}{\langle cd \rangle \langle ef \rangle^2} - \frac{\langle \alpha d \rangle^3 \langle ce \rangle [dc] \langle c\alpha \rangle}{\langle cd \rangle^2 \langle ef \rangle \langle f\alpha \rangle} \right) \\
&= \langle \alpha q \rangle^2 \left(- \frac{[fc]^3}{t_{\alpha\beta c} [f|K_{\alpha\beta}|c]} \frac{[\beta|K_{\alpha\beta}|c]^3}{[\beta|K_{\alpha\beta}|q]^3} + \frac{[ef] \langle df \rangle}{\langle cd \rangle \langle ef \rangle^2} \frac{[\beta|K_{\alpha\beta}|e]^3}{[\beta|K_{\alpha\beta}|q]^3} - \frac{\langle ce \rangle [dc]}{\langle cd \rangle^2 \langle ef \rangle} \frac{[\beta|K_{\alpha\beta}|d]^3 [\beta|K_{\alpha\beta}|c]}{[\beta|K_{\alpha\beta}|q]^3 [\beta|K_{\alpha\beta}|f]} \right) \\
&= \langle \alpha q \rangle^2 \left(- \frac{[fc]^3}{t_{\alpha\beta c} [f|K_{\alpha\beta}|c]} \frac{[q|K_{\alpha\beta}|c]^3}{[q|K_{\alpha\beta}|q]^3} + \frac{[ef] \langle df \rangle}{\langle cd \rangle \langle ef \rangle^2} \frac{[q|K_{\alpha\beta}|e]^3}{[q|K_{\alpha\beta}|q]^3} - \frac{\langle ce \rangle [dc]}{\langle cd \rangle^2 \langle ef \rangle} \frac{[q|K_{\alpha\beta}|d]^3 [q|K_{\alpha\beta}|c]}{[q|K_{\alpha\beta}|q]^3 [q|K_{\alpha\beta}|f]} \right) \\
&\quad + \frac{3s_{\alpha\beta} \langle \alpha q \rangle^2 [\beta q]}{[q|K_{\alpha\beta}|q]} \left(- \frac{[fc]^3 \langle qc \rangle}{t_{\alpha\beta c} [f|K_{\alpha\beta}|c] [\beta|K_{\alpha\beta}|q]} \frac{[\beta|K_{\alpha\beta}|c]^2}{[\beta|K_{\alpha\beta}|q]^2} + \frac{[ef] \langle df \rangle \langle qe \rangle}{\langle cd \rangle \langle ef \rangle^2 [\beta|K_{\alpha\beta}|q]} \frac{[\beta|K_{\alpha\beta}|e]^2}{[\beta|K_{\alpha\beta}|q]^2} \right. \\
&\quad \left. - \frac{\langle ce \rangle [dc]}{\langle cd \rangle^2 \langle ef \rangle} \frac{[\beta|K_{\alpha\beta}|d]^2}{[\beta|K_{\alpha\beta}|f] [\beta|K_{\alpha\beta}|q]^2} \left(\langle qd \rangle [\beta|K_{\alpha\beta}|c] + \frac{\langle fc \rangle [q|K_{\alpha\beta}|q] [\beta|K_{\alpha\beta}|d]}{3[q|K_{\alpha\beta}|f]} \right) \right) \\
&\hspace{20em} + \mathcal{O}(s_{\alpha\beta}^2) \tag{A7}
\end{aligned}$$

and so we obtain

$$\begin{aligned}
\tau_6^{\text{d.p.}} &= \frac{i}{3} \frac{\langle q|\alpha\beta|q \rangle [q|K_{\alpha\beta}|q] \langle \alpha q \rangle^2}{s_{\alpha\beta} [q|K_{\alpha\beta}|c] \langle de \rangle^2 \langle \beta q \rangle^2} \left(- \frac{[fc]^3}{t_{\alpha\beta c} [f|K_{\alpha\beta}|c]} \frac{[q|K_{\alpha\beta}|c]^3}{[q|K_{\alpha\beta}|q]^3} \right. \\
&\quad \left. + \frac{[ef] \langle df \rangle}{\langle cd \rangle \langle ef \rangle^2} \frac{[q|K_{\alpha\beta}|e]^3}{[q|K_{\alpha\beta}|q]^3} - \frac{\langle ce \rangle [dc]}{\langle cd \rangle^2 \langle ef \rangle} \frac{[q|K_{\alpha\beta}|d]^3 [q|K_{\alpha\beta}|c]}{[q|K_{\alpha\beta}|q]^3 [q|K_{\alpha\beta}|f]} \right). \tag{A8}
\end{aligned}$$

When $K_{\alpha\beta}^2 \rightarrow 0$ this reduces to ⁷

$$\tau_6^{\text{d.p.}} = \frac{\langle \alpha q \rangle^2 \langle q|\alpha\beta|q \rangle}{\langle \beta q \rangle^2 \langle kq \rangle^2} \times \frac{1}{s_{\alpha\beta}} \times A_5^{(1)}(k^-, c^+, d^+, e^+, f^+) \tag{A9}$$

which exactly reproduces the first factorisation in fig. 4 if we allow α and β to be massive. This term will generate the double pole after integration. The order $s_{\alpha\beta}^1$ term in (A7) will contribute to the subleading single pole in s_{ab} .

The fourth line in (A5) contains the $[\alpha\beta]^{-1}$ factor. To extract the factorisation in fig. 4b

⁷ From here on $k = K_{\alpha\beta}$; k^b is defined as in equation (6.1).

we use the following rearrangements:

$$\frac{1}{[\alpha\beta]} \left(\frac{[\beta X]}{[\beta Y]} - \frac{[k^b X]}{[k^b Y]} \right) = \frac{1}{[\alpha\beta]} \frac{[\beta k^b][XY]}{[\beta Y][k^b Y]} = -\frac{1}{[\alpha\beta]} \frac{\langle q|k|\beta\rangle[XY]}{[\beta Y]\langle q|k|Y\rangle} = -\frac{\langle q\alpha\rangle[XY]}{[\beta Y]\langle q|k|Y\rangle}, \quad (\text{A10})$$

$$\frac{[\beta f]^3}{[\alpha\beta][f\alpha]} = \frac{[\beta f]^3}{[\alpha\beta][f\alpha]} \frac{[\alpha q]}{[\alpha q]} = \frac{[\beta f]^2}{[\alpha\beta][f\alpha]} [\alpha q][\beta f] = \frac{[\beta f]^2[qf]}{[f\alpha][\alpha q]} - \frac{[\beta f]^2[\beta q]}{[\alpha\beta][\alpha q]}, \quad (\text{A11})$$

and

$$\frac{[\beta f]^2[\beta q]\langle\beta\alpha\rangle}{[\alpha q]} = -\frac{\langle\alpha k^b\rangle[\beta q]^2}{[\alpha q][k^b q]} [f k^b]^2 + s_{\alpha\beta} \frac{[f|q|\alpha]}{[q|k|q]} \frac{([f\beta][\beta q][k^b q] + [\beta q]^2[f k^b])}{[\alpha q][k^b q]}. \quad (\text{A12})$$

Applying (A10) to the fourth line in (A5):

$$\begin{aligned} & \frac{[\beta f]^3}{[\alpha\beta][f\alpha]t_{cde}} \left(\frac{[\beta c][cd]}{\langle de\rangle[\beta|K_{cd}|e]} - \frac{[de][ef]}{\langle cd\rangle[f|k|c]} + \frac{[ce]}{\langle cd\rangle\langle de\rangle} \right) \\ &= \frac{[\beta f]^3}{[\alpha\beta][f\alpha]t_{cde}} \left(\frac{[k^b c][cd]}{\langle de\rangle[k^b|K_{cd}|e]} - \frac{[de][ef]}{\langle cd\rangle[f|k|c]} + \frac{[ce]}{\langle cd\rangle\langle de\rangle} \right) + \frac{\langle q\alpha\rangle[\beta f]^3[cd][c|K_{cd}|e]}{[f\alpha][\beta|K_{cd}|e]\langle e|K_{cd}k|q\rangle\langle de\rangle t_{cde}} \end{aligned} \quad (\text{A13})$$

Applying (A11) and (A12) to the pre-factor:

$$\frac{[\beta f]^3}{[\alpha\beta][f\alpha]} = \frac{[\beta f]^2[qf]}{[f\alpha][\alpha q]} + \frac{\langle\alpha k^b\rangle[\beta q]^2}{s_{\alpha\beta}[\alpha q][k^b q]} [f k^b]^2 - \frac{[f|q|\alpha]}{[q|k|q]} \frac{([f\beta][\beta q][k^b q] + [\beta q]^2[f k^b])}{[\alpha q][k^b q]}, \quad (\text{A14})$$

we obtain

$$\tau_6^{\text{s.b.}} = -\frac{i\langle\alpha q\rangle^2[q\beta|q]^2[q\alpha\beta|q]}{3\langle\beta q\rangle^2[q|\alpha|q]^2 s_{\alpha\beta}[k^b q]^2 t_{cde}} \left(\frac{[k^b c][cd]}{\langle de\rangle[k^b|K_{cd}|e]} - \frac{[de][ef]}{\langle cd\rangle[f|k|c]} + \frac{[ce]}{\langle cd\rangle\langle de\rangle} \right). \quad (\text{A15})$$

When $K_{\alpha\beta}^2 \rightarrow 0$ this reduces to

$$\tau_6^{\text{s.b.}} = -\frac{[\beta q]^2[q\alpha\beta|q]}{[\alpha q]^2[k q]^2} \times \frac{1}{s_{\alpha\beta}} \times A_5^{(1)}(k^+, c^+, d^+, e^+, f^+) \quad (\text{A16})$$

which exactly reproduces the factorisation in fig. 4b if we allow α and β to be massive.

The remaining terms we gather into $\tau_6^{\text{n.f.}}$. Explicitly,

$$\begin{aligned}
\tau_6^{\text{n.f.}} = & \frac{i}{3} \left[\frac{\langle cq \rangle [q|\alpha|q]}{\langle \beta c \rangle [q|k|c] \langle \alpha q \rangle \langle \beta q \rangle \langle de \rangle^2} \left(\frac{[fc]^3 \langle c\alpha \rangle^3}{t_{\alpha\beta c} [f|k|c]} + \frac{\langle \alpha e \rangle^3 [ef] \langle df \rangle}{\langle cd \rangle \langle ef \rangle^2} - \frac{\langle \alpha d \rangle^3 \langle ce \rangle [dc] \langle c\alpha \rangle}{\langle cd \rangle^2 \langle ef \rangle \langle f\alpha \rangle} \right) \right. \\
& + \frac{\langle \alpha q \rangle^2}{\langle \beta q \rangle^2} \frac{3 \langle q|\alpha\beta|q \rangle [\beta q]}{[\beta|k|q] [q|k|c] \langle de \rangle^2} \left(- \frac{[fc]^3 \langle qc \rangle}{t_{\alpha\beta c} [f|k|c]} \frac{[\beta|k|c]^2}{[\beta|k|q]^2} + \frac{[ef] \langle df \rangle \langle qe \rangle [\beta|k|e]^2}{\langle cd \rangle \langle ef \rangle^2 [\beta|k|q]^2} \right. \\
& \quad \left. - \frac{\langle ce \rangle [dc]}{\langle cd \rangle^2 \langle ef \rangle} \frac{[\beta|K_{\alpha\beta}|d]^2}{[\beta|K_{\alpha\beta}|f] [\beta|K_{\alpha\beta}|q]^2} \left(\langle qd \rangle [\beta|K_{\alpha\beta}|c] + \frac{\langle fc \rangle [q|K_{\alpha\beta}|q] [\beta|K_{\alpha\beta}|d]}{3[q|K_{\alpha\beta}|f]} \right) \right) \\
& + \frac{1}{\langle \beta c \rangle \langle de \rangle^2} \left(\frac{3[\beta f] [f|c|\alpha]^2}{t_{\alpha\beta c} [f|k|c]} - \frac{\langle \alpha d \rangle^3 \langle ce \rangle [\beta d]}{\langle cd \rangle^2 \langle ef \rangle \langle f\alpha \rangle} \right) \\
& + \frac{[\beta|K_{cd}|\alpha]^3}{\langle cd \rangle^2 \langle ef \rangle \langle f\alpha \rangle t_{\beta cd} [\beta|K_{cd}|e]} - \frac{\langle \alpha c \rangle^3 [\beta c] \langle \beta d \rangle}{\langle \beta c \rangle^2 \langle cd \rangle^2 \langle de \rangle \langle ef \rangle \langle f\alpha \rangle} \\
& + \frac{[\beta f]^2 [qf]}{[f\alpha] [\alpha q] t_{cde}} \frac{1}{\langle de \rangle} \left(\frac{[k^b c] [cd]}{[k^b |K_{cd}|e]} - \frac{[de][ef]}{\langle cd \rangle [f|k|c]} + \frac{[ce]}{\langle cd \rangle \langle de \rangle} \right) \\
& - \frac{[f|q|\alpha]}{[q|k|q]} \frac{([f\beta] [\beta q] [k^b q] + [\beta q]^2 [f k^b])}{[\alpha q] [k^b q] t_{cde}} \left(\frac{[k^b c] [cd]}{[k^b |K_{cd}|e]} - \frac{[de][ef]}{\langle cd \rangle [f|k|c]} + \frac{[ce]}{\langle cd \rangle \langle de \rangle} \right) \\
& \left. + \frac{\langle q\alpha \rangle [\beta f]^3 [cd] [c|K_{cd}|e]}{[f\alpha] [\beta|K_{cd}|e] \langle e|K_{cd}k|q \rangle \langle de \rangle t_{cde}} \right]. \tag{A17}
\end{aligned}$$

Applying (A6) and $\alpha + \beta = k$ and applying some minor rearrangements gives

$$\begin{aligned}
\tau_6^{\text{n.f.}} = & \frac{i}{3} \frac{\langle \alpha q \rangle^2}{\langle \beta q \rangle^2} \left[[q|\alpha|q] \frac{\langle cq \rangle}{[q|k|c]^2 [q|k|q]^2 \langle de \rangle^2} \left(- \frac{[fc]^3 [q|k|c]^3}{t_{\alpha\beta c} [f|k|c]} \right. \right. \\
& + \left. \frac{[ef] \langle df \rangle [q|k|e]^3}{\langle cd \rangle \langle ef \rangle^2} - \frac{\langle ce \rangle [dc] [q|k|d]^3 [q|k|c]}{\langle cd \rangle^2 \langle ef \rangle [q|k|f]} \right) - [c|\beta|d] \frac{[q|k|c]}{\langle cd \rangle^2 \langle de \rangle \langle ef \rangle [q|k|f]} \\
& - 3[q|\beta|q] \frac{1}{[q|k|c] \langle de \rangle^2} \left(- \frac{[fc]^3 \langle qc \rangle [q|k|c]^2}{t_{\alpha\beta c} [f|k|c] [q|k|q]^2} + \frac{[ef] \langle df \rangle \langle qe \rangle [q|k|e]^2}{\langle cd \rangle \langle ef \rangle^2 [q|k|q]^2} \right. \\
& \quad \left. - \frac{\langle ce \rangle [dc]}{\langle cd \rangle^2 \langle ef \rangle} \frac{[q|K_{\alpha\beta}|d]^2}{[q|K_{\alpha\beta}|f] [q|K_{\alpha\beta}|q]^2} \left(\langle qd \rangle [q|K_{\alpha\beta}|c] + \frac{\langle fc \rangle [q|K_{\alpha\beta}|q] [q|K_{\alpha\beta}|d]}{3[q|K_{\alpha\beta}|f]} \right) \right) \\
& - 3[f|\beta|q] \frac{[fc]^2 [q|k|c]}{\langle de \rangle^2 t_{\alpha\beta c} [f|k|c] [q|k|q]} - [d|\beta|q] \frac{[q|k|d]^3 \langle ce \rangle}{\langle cd \rangle^2 \langle de \rangle^2 \langle ef \rangle [q|k|c] [q|k|f] [q|k|q]} \\
& + \left(\frac{[q|\beta|q]^2 [f|k|q]}{[q|\alpha|q] [q|k|q]^2} + \frac{[f|\beta|q] [q|\beta|q]}{[q|k|q] [q|\alpha|q]} + \frac{[f|\beta|q]^2}{[f|\alpha|q] [q|\alpha|q]} \right) \times \\
& \quad \frac{[fq]}{t_{cde}} \left(\frac{[k^b c] [cd]}{\langle de \rangle [k^b | K_{cd} | e]} - \frac{[de] [ef]}{\langle cd \rangle [f|k|c]} + \frac{[ce]}{\langle cd \rangle \langle de \rangle} \right) \\
& - \frac{[\beta | K_{cd} | \alpha]^3 \langle \beta q \rangle^3}{\langle f \alpha \rangle t_{\beta cd} \langle q | \beta K_{cd} | e \rangle \langle \alpha q \rangle^2 \langle cd \rangle^2 \langle ef \rangle} - \frac{1}{[f|\alpha|q] \langle q | \beta K_{cd} | e \rangle \langle e | K_{cd} k | q \rangle \langle de \rangle t_{cde}} \frac{[f|\beta|q]^3 [cd] [c|K_{cd}|e]}{[f|\alpha|q] \langle q | \beta K_{cd} | e \rangle \langle e | K_{cd} k | q \rangle \langle de \rangle t_{cde}} \Big].
\end{aligned} \tag{A18}$$

Some of the terms can be further expanded to aid integration:

$$\begin{aligned}
[c|\beta|d] &= -[c|\alpha|d] + [c|k|d] = -\frac{\langle d\alpha \rangle}{\langle q\alpha \rangle} [c|\alpha|q] + [c|k|d] \\
\frac{[q|\beta|q]^2}{[q|\alpha|q]} &= [q|\alpha|q] - 2[q|k|q] + \frac{[q|k|q]^2}{[q|\alpha|q]} \\
\frac{[f|\beta|q] [q|\beta|q]}{[q|\alpha|q]} &= -[f|\beta|q] - \frac{[f|\alpha|q] [q|k|q]}{[q|\alpha|q]} + \frac{[f|k|q] [q|k|q]}{[q|\alpha|q]} \\
\frac{[f|\beta|q]^2}{[f|\alpha|q] [q|\alpha|q]} &= \frac{[f|\alpha|q]}{[q|\alpha|q]} - 2 \frac{[f|k|q]}{[q|\alpha|q]} + \frac{[f|k|q]^2}{[f|\alpha|q] [q|\alpha|q]} \\
\frac{[f|\beta|q]^3}{[f|\alpha|q] \langle q | \beta K_{cd} | e \rangle} &= -\frac{[f|\alpha|q]^2}{\langle q | \beta K_{cd} | e \rangle} + 3 \frac{[f|\alpha|q] [f|k|q]}{\langle q | \beta K_{cd} | e \rangle} - 3 \frac{[f|k|q]^2}{\langle q | \beta K_{cd} | e \rangle} + \frac{[f|k|q]^3}{[f|\alpha|q] \langle q | \beta K_{cd} | e \rangle}
\end{aligned} \tag{A19}$$

The term with the $t_{\beta cd}^{-1}$ factor is the most difficult to deal with:

$$\begin{aligned}
\frac{[\beta|K_{cd}|\alpha]^3 \langle \beta q \rangle^3}{\langle f \alpha \rangle t_{\beta cd} \langle q|\beta K_{cd}|e \rangle \langle \alpha q \rangle^2} &= \frac{[\beta|K_{cd}|\beta]^3 \langle \alpha q \rangle}{\langle f \alpha \rangle t_{\beta cd} \langle q|\beta K_{cd}|e \rangle} + \mathcal{O}(\langle \alpha \beta \rangle) \\
&= -\frac{(t_{\beta cd} - s_{cd})^3}{t_{\beta cd} \langle q|\beta K_{cd}|e \rangle} \frac{[q|k|q]}{[q|k|f]} + \mathcal{O}(\langle \alpha \beta \rangle) \\
&= -\frac{[q|k|q]}{[q|k|f]} \left(\frac{[\beta|K_{cd}|\beta]^2}{\langle q|\beta K_{cd}|e \rangle} - \frac{[\beta|K_{cd}|\beta] s_{cd}}{\langle q|\beta K_{cd}|e \rangle} + \frac{s_{cd}^2}{\langle q|\beta K_{cd}|e \rangle} - \frac{s_{cd}^3}{t_{\beta cd} \langle q|\beta K_{cd}|e \rangle} \right) + \mathcal{O}(\langle \alpha \beta \rangle)
\end{aligned} \tag{A20}$$

and

$$\begin{aligned}
[\beta|K_{cd}|\beta] &= [c|\beta|c] + [d|\beta|d] = -[c|\alpha|c] - [d|\alpha|d] + ([c|k|c] + [d|k|d]) \\
&= \frac{\langle \alpha|K_{cd}|\alpha \rangle}{\langle q \alpha \rangle} + ([c|k|c] + [d|k|d]).
\end{aligned} \tag{A21}$$

This yields the final form for $\tau_6^{\text{n.f.}}$. Thus the full amplitude can be written as

$$A_6^{(1)}(\alpha^-, \beta^+, c^+, d^+, e^+, f^+) = \tau_6^{\text{d.p.}} + \tau_6^{\text{s.b.}} + \tau_6^{\text{n.f.}} + \mathcal{O}(\langle \alpha \beta \rangle) \tag{A22}$$

where

$$\begin{aligned}
\tau_6^{\text{d.p.}} &= \frac{i}{3} \frac{\langle q|\alpha\beta|q \rangle [q|K_{\alpha\beta}|q] \langle \alpha q \rangle^2}{s_{\alpha\beta} [q|K_{\alpha\beta}|c] \langle de \rangle^2 \langle \beta q \rangle^2} \left(-\frac{[fc]^3}{t_{\alpha\beta c} [f|K_{\alpha\beta}|c]} \frac{[q|K_{\alpha\beta}|c]^3}{[q|K_{\alpha\beta}|q]^3} \right. \\
&\quad \left. + \frac{[ef] \langle df \rangle}{\langle cd \rangle \langle ef \rangle^2} \frac{[q|K_{\alpha\beta}|e]^3}{[q|K_{\alpha\beta}|q]^3} - \frac{\langle ce \rangle [dc]}{\langle cd \rangle^2 \langle ef \rangle} \frac{[q|K_{\alpha\beta}|d]^3 [q|K_{\alpha\beta}|c]}{[q|K_{\alpha\beta}|q]^3 [q|K_{\alpha\beta}|f]} \right), \\
\tau_6^{\text{s.b.}} &= -\frac{i}{3} \frac{[q|\beta|q]^2 [q|\alpha\beta|q]}{[q|\alpha|q]^2 [q|K_{\alpha\beta}|q]^2 s_{\alpha\beta}} \frac{1}{t_{cde}} [f|K_{\alpha\beta}|q]^2 \left(\frac{\langle q|K_{\alpha\beta}|c \rangle [cd]}{\langle de \rangle \langle q|K_{\alpha\beta}K_{cd}|e \rangle} - \frac{[de][ef]}{\langle cd \rangle [f|k|c]} + \frac{[ce]}{\langle cd \rangle \langle de \rangle} \right)
\end{aligned} \tag{A23}$$

and

$$\begin{aligned}
\tau_6^{\text{n.f.}} = & \frac{i \langle \alpha q \rangle^2}{3 \langle \beta q \rangle^2} \left[[q|\alpha|q] \frac{\langle cq \rangle}{[q|k|c]^2 [q|k|q]^2 \langle de \rangle^2} \left(- \frac{[fc]^3 [q|k|c]^3}{t_{\alpha\beta c} [f|k|c]} \right. \right. \\
& + \frac{[ef] \langle df \rangle [q|k|e]^3}{\langle cd \rangle \langle ef \rangle^2} - \frac{\langle ce \rangle [dc] [q|k|d]^3 [q|k|c]}{\langle cd \rangle^2 \langle ef \rangle [q|k|f]} \left. \right) \\
& + \left(\frac{\langle d\alpha \rangle}{\langle q\alpha \rangle} [c|\alpha|q] - [c|k|d] \right) \frac{[q|k|c]}{\langle cd \rangle^2 \langle de \rangle \langle ef \rangle [q|k|f]} \\
& - 3[q|\beta|q] \frac{1}{[q|k|c] \langle de \rangle^2} \left(- \frac{[fc]^3 \langle qc \rangle [q|k|c]^2}{t_{\alpha\beta c} [f|k|c] [q|k|q]^2} + \frac{[ef] \langle df \rangle \langle qe \rangle [q|k|e]^2}{\langle cd \rangle \langle ef \rangle^2 [q|k|q]^2} \right. \\
& \left. - \frac{\langle ce \rangle [dc] [q|k|d]^2}{\langle cd \rangle^2 \langle ef \rangle [q|k|f] [q|k|q]^2} \left(\langle qd \rangle [q|k|c] + \frac{\langle fc \rangle [q|k|q] [q|k|d]}{3[q|k|f]} \right) \right) \\
& - 3[f|\beta|q] \frac{[fc]^2 [q|k|c]}{\langle de \rangle^2 t_{\alpha\beta c} [f|k|c] [q|k|q]} - [d|\beta|q] \frac{[q|k|d]^3 \langle ce \rangle}{\langle cd \rangle^2 \langle de \rangle^2 \langle ef \rangle [q|k|c] [q|k|f] [q|k|q]} \\
& + \left(\frac{[f|k|q]}{[q|k|q]^2} \left([q|\alpha|q] - 2[q|k|q] + \frac{[q|k|q]^2}{[q|\alpha|q]} \right) + \frac{[f|\alpha|q]}{[q|\alpha|q]} - 2 \frac{[f|k|q]}{[q|\alpha|q]} + \frac{[f|k|q]^2}{[f|\alpha|q] [q|\alpha|q]} \right. \\
& \left. + \frac{1}{[q|k|q]} \left(- [f|\beta|q] - \frac{[f|\alpha|q] [q|k|q]}{[q|\alpha|q]} + \frac{[f|k|q] [q|k|q]}{[q|\alpha|q]} \right) \right) \times \\
& \frac{[fq]}{t_{cde}} \left(\frac{[k^b c] [cd]}{\langle de \rangle [k^b | K_{cd} | e]} - \frac{[de] [ef]}{\langle cd \rangle [f|k|c]} + \frac{[ce]}{\langle cd \rangle \langle de \rangle} \right) \\
& + \frac{[q|k|q]}{[q|k|f] \langle cd \rangle^2 \langle ef \rangle} \left(\frac{(\langle \alpha | K_{cd} | \alpha | q \rangle + \langle q \alpha \rangle ([c|k|c] + [d|k|d]))^2}{\langle q \alpha \rangle^2 \langle q | \beta K_{cd} | e \rangle} + \frac{s_{cd}^2}{t_{\beta cd} \langle q | \beta K_{cd} | e \rangle} \right. \\
& \left. - \frac{s_{cd}^3}{t_{\beta cd} \langle q | \beta K_{cd} | e \rangle} - \frac{(\langle \alpha | K_{cd} | \alpha | q \rangle + \langle q \alpha \rangle ([c|k|c] + [d|k|d])) s_{cd}}{\langle q \alpha \rangle \langle q | \beta K_{cd} | e \rangle} \right) \\
& - \frac{[cd] [c | K_{cd} | e]}{\langle e | K_{cd} | q \rangle \langle de \rangle t_{cde}} \times \\
& \left. \left(- \frac{[f|\alpha|q]^2}{\langle q | \beta K_{cd} | e \rangle} + 3 \frac{[f|\alpha|q] [f|k|q]}{\langle q | \beta K_{cd} | e \rangle} - 3 \frac{[f|k|q]^2}{\langle q | \beta K_{cd} | e \rangle} + \frac{[f|k|q]^3}{[f|\alpha|q] \langle q | \beta K_{cd} | e \rangle} \right) \right], \tag{A24}
\end{aligned}$$

where the expansions (A19), (A20) and (A21) have been applied to (A18) to produce the final form of $\tau_6^{\text{n.f.}}$. Using this form we take α and β off-shell. The $\tau_6^{\text{d.p}}$ and $\tau_6^{\text{s.b}}$ terms then exactly reproduce the two contributions in fig. 4, while $\tau_6^{\text{n.f}}$ is finite as $s_{\alpha\beta} \rightarrow 0$. The first two terms then ensure that condition **I** is satisfied and all three reproduce the amplitude in the on-shell limit up to terms of order $\langle \alpha \beta \rangle$.

Appendix B: Integrations

In order to determine the contribution from the diagram shown in fig. 3 we need to evaluate the integral in (6.3):

$$i \frac{1}{\langle a q \rangle \langle b q \rangle} \int \frac{d^D \ell}{\ell^2 \alpha^2 \beta^2} [a | \ell | q] [b | \ell | q] \frac{\langle \beta q \rangle^2}{\langle \alpha q \rangle^2} \tau_6. \quad (\text{B1})$$

Feynman parametrisation is carried out in the usual way:

$$\begin{aligned} \frac{1}{\ell^2 \alpha^2 \beta^2} &= \Gamma(3) \int_0^1 \int_0^{1-x_2} dx_1 dx_2 \frac{1}{(\ell^2 + 2\ell \cdot (x_1 a - x_2 b))^3} \\ &= \Gamma(3) \int_0^1 \int_0^{1-x_2} dx_1 dx_2 \frac{1}{((\ell + x_1 a - x_2 b)^2 + x_1 x_2 s_{ab})^3}; \end{aligned} \quad (\text{B2})$$

where upon the shift $\ell \rightarrow \ell - x_1 a + x_2 b$ the denominator becomes symmetric. The numerators of $\mathcal{I}_{\text{d.p.}}$ and $\mathcal{I}_{\text{n.f.}}$ contain loop momenta contracted solely with λ_q , thus all quadratic and higher tensor reductions vanish.

The $\mathcal{I}_{\text{d.p.}}$ piece

Extracting the loop momentum dependent terms from $\mathcal{I}_{\text{d.p.}}$ we have

$$\begin{aligned} &\int \frac{d^D \ell}{\ell^2 \alpha^2 \beta^2} [a | \ell | q] [b | \ell | q] \langle q | \alpha \beta | q \rangle \\ &= \Gamma(3) \int_0^1 \int_0^{1-x_2} dx_1 dx_2 \int \frac{d^D \ell}{((\ell + x_1 a - x_2 b)^2 + x_1 x_2 s_{ab})^3} [a | \ell | q] [b | \ell | q] \langle q | (\ell + a) k | q \rangle \\ &= \Gamma(3) \int_0^1 \int_0^{1-x_2} dx_1 dx_2 \int \frac{d^D \ell}{(\ell^2 + x_1 x_2 s_{ab})^3} x_1 x_2 [a | b | q] [b | a | q] \langle q | (x_2 b + (1 - x_1) a) k | q \rangle \\ &= \Gamma(3) \frac{-2\pi^{\frac{D}{2}} i}{\Gamma(\frac{D}{2})} \int_0^1 \int_0^{1-x_2} dx_1 dx_2 [a | b | q] [b | a | q] \langle q | a b | q \rangle x_1 x_2 (1 - x_1 - x_2) \int_0^\infty \frac{\ell_E^{D-1} d\ell_E}{(\ell_E^2 - x_1 x_2 s_{ab})^3}. \end{aligned} \quad (\text{B3})$$

The integral

$$\int_0^\infty \frac{\ell_E^{D-1} d\ell_E}{(\ell_E^2 + \Delta)^3} = \frac{1}{2} \int_0^\infty \frac{(\ell_E^2)^{\frac{D}{2}-1} d\ell_E^2}{(\ell_E^2 + \Delta)^3} = \frac{1}{2} \frac{1}{\Delta^3} \int_0^\infty \frac{(\ell_E^2)^{\frac{D}{2}-1} d\ell_E^2}{(\ell_E^2 + \Delta)^3} = \frac{\Delta^{\frac{D}{2}-3} \Gamma(3 - \frac{D}{2}) \Gamma(\frac{D}{2})}{2 \Gamma(3)}. \quad (\text{B4})$$

So

$$\begin{aligned} \int \frac{d^D \ell}{\ell^2 \alpha^2 \beta^2} [a | \ell | q] [b | \ell | q] \langle q | \alpha \beta | q \rangle &= -i\pi^{\frac{D}{2}} \Gamma(3 - \frac{D}{2}) \frac{[ab]^3 \langle a q \rangle^2 \langle b q \rangle^2}{s_{ab}^{3-\frac{D}{2}}} \\ &\int_0^1 \int_0^{1-x_2} dx_1 dx_2 [(1 - x_1 - x_2)(-x_1 x_2)^{\frac{D}{2}-2}] \end{aligned} \quad (\text{B5})$$

and

$$\begin{aligned}
\int_0^1 \int_0^{1-x_2} dx_1 dx_2 [(1-x_1-x_2)(-x_1 x_2)^{\frac{D}{2}-2}] &= \int_0^1 dx_1 x_1^{\frac{D}{2}-1} (1-x_1)^{\frac{D}{2}} \left(-\frac{1}{\frac{D}{2}-1} + \frac{2}{D}\right) \\
&= \frac{\Gamma(\frac{D}{2}-1)\Gamma(\frac{D}{2}+1)}{\Gamma(D)} \frac{-4}{D(D-2)} \\
&= \frac{\Gamma(1-\epsilon)\Gamma(3-\epsilon)}{\Gamma(4-2\epsilon)} \frac{-1}{(2-\epsilon)(1-\epsilon)} \\
&= \frac{\Gamma(1-\epsilon)^2}{\Gamma(4-2\epsilon)} (-1) ; \tag{B6}
\end{aligned}$$

so that we can simply write

$$\int d\Lambda_{ab}^{\alpha\beta} [\langle q|\alpha\beta|q\rangle] = -\frac{1}{6} \frac{[ab]}{\langle ab\rangle} \langle q|ab|q\rangle + \mathcal{O}(\epsilon) . \tag{B7}$$

The $\mathcal{I}_{n.f.}$ piece

Another algebraic step is needed before integration can easily be carried out on $\tau_6^{n.f.}$:

$$\frac{\langle X\alpha\rangle}{\langle Y\alpha\rangle} = \frac{\langle Xa\rangle}{\langle Ya\rangle} + \mathcal{O}(\langle a\alpha\rangle) , \tag{B8}$$

implies that

$$\frac{(\langle\alpha|K_{cd}\alpha|q\rangle + \langle q\alpha\rangle ([c|k|c] + [d|k|d]))}{\langle q\alpha\rangle \langle q|\beta K_{cd}|e\rangle} = \frac{(\langle a|K_{cd}\ell|q\rangle + \langle qa\rangle ([c|b|c] + [d|b|d]))}{\langle qa\rangle \langle q|\beta K_{cd}|e\rangle} + \mathcal{O}(\langle a\alpha\rangle) . \tag{B9}$$

After this step, the relevant triangle integrals are

$$\begin{aligned}
\int d\Lambda_{ab}^{\alpha\beta} [1] &= -\frac{1}{2} \frac{[ab]}{\langle ab\rangle} + \mathcal{O}(\epsilon) , \\
\int d\Lambda_{ab}^{\alpha\beta} [[X|\alpha|q]] &= -\frac{1}{6} \frac{[ab]}{\langle ab\rangle} [X|b+2a|q] + \mathcal{O}(\epsilon) , \\
\int d\Lambda_{ab}^{\alpha\beta} [[X|\beta|q]] &= -\frac{1}{6} \frac{[ab]}{\langle ab\rangle} [X|2b+a|q] + \mathcal{O}(\epsilon) . \tag{B10}
\end{aligned}$$

Integrals with extra propagators involve a little bit more subtlety.

Setting $K_\chi = \lambda_q \bar{\lambda}_Y$, some terms in (A24) have factors which can be promoted to full propagators:

$$\frac{1}{[Y|\beta|q]} = \frac{1}{(\beta + K_\chi)^2} + \mathcal{O}(\beta^2) . \tag{B11}$$

The numerator can be re-written using

$$\begin{aligned} [a|\ell|q][b|\ell|q] &= \frac{(\alpha^2 - \ell^2)\langle q|b\ell|q\rangle + (\beta^2 - \ell^2)\langle q|a\ell|q\rangle + \ell^2\langle q|ba|q\rangle}{\langle a b\rangle} \\ &= \frac{\beta^2\langle q|a\ell|q\rangle + \alpha^2\langle q|b\ell|q\rangle - \ell^2\langle q|(\ell - b)K_{ab}|q\rangle}{\langle a b\rangle}. \end{aligned} \quad (\text{B12})$$

The pole has now been made manifest, thus the integral need not contribute a pole to contribute to the residue. For each term in (B12) the α^2 , β^2 and ℓ^2 factors cancel with the propagators in $\int d\Lambda$. For terms involving a single extra loop momentum dependent factor in the denominator this yields a sum of triangle integrals. For the α^2 term in (B12)

$$\begin{aligned} \frac{\langle q|b\ell|q\rangle}{\ell^2\beta^2(\beta + K_\chi)^2} &\rightarrow \frac{\langle q|b\ell|q\rangle}{((\beta - x_2b + x_1\chi)^2 + x_1x_2[b|\chi|b])^3} \\ &\rightarrow \frac{\langle q|b(x_2b - x_1\chi)|q\rangle}{(\beta^2 + x_1x_2[b|\chi|b])^3} = 0 \quad , \end{aligned} \quad (\text{B13})$$

and for the ℓ^2 term

$$\frac{\langle q|(\ell - b)K_{ab}|q\rangle}{\alpha^2\beta^2(\beta + K_\chi)^2} \rightarrow \frac{\langle q|(\ell - b)K_{ab}|q\rangle}{((\beta - x_2(b + a) + x_1\chi)^2 - x_2s_{ab} + x_1x_2[\chi|K_{ab}|\chi])^3} \rightarrow 0 \quad . \quad (\text{B14})$$

Thus only the β^2 term survives. For the cubic box

$$\begin{aligned} \frac{\langle q|a\ell|q\rangle[X|\ell|q]}{\ell^2\alpha^2(\beta + K_\chi)^2} &\rightarrow \frac{\langle q|a\ell|q\rangle[X|\ell|q]}{((\ell + x_2a - x_1(b + \chi))^2 + x_1x_2(s_{ab} + [a|\chi|a]) - (x_1 - x_1^2)[b|\chi|b])^3} \\ &\rightarrow \frac{x_1\langle q|a(b + \chi)|q\rangle(-x_2[X|a|q] + x_1[X|b + \chi|q])}{(\ell^2 + x_1x_2(s_{ab} + [a|\chi|a]) - (x_1 - x_1^2)[b|\chi|b])^3} \\ &= \frac{x_1\langle q|ab|q\rangle(-x_2[X|a|q] + x_1[X|b|q])}{(\ell^2 + x_1x_2[a|\chi|a] - (x_1 - x_1^2)[b|\chi|b])^3} + \mathcal{O}(s_{ab}) ; \end{aligned} \quad (\text{B15})$$

so in this case

$$\Delta = -x_1x_2([a|\chi|a]) + (x_1 - x_1^2)[b|\chi|b] . \quad (\text{B16})$$

Carrying out the integration:

$$\int d\Lambda_{ab}^{\alpha\beta} \left[\frac{[X|\ell|q]}{(\beta + K_\chi)^2} \right] \Big|_{\mathbb{Q}} = \frac{1}{2} \frac{[ab][X|a|q]}{\langle a b\rangle [a|\chi|a]} . \quad (\text{B17})$$

Quadratic boxes and quadratic or cubic pentagons lead to nothing but transcendental func-

tions:

$$\begin{aligned}
\int d\Lambda_{ab}^{\alpha\beta} \left[\frac{1}{(\alpha + X)^2} \right] \Big|_{\mathbb{Q}} &= 0, \\
\int d\Lambda_{ab}^{\alpha\beta} \left[\frac{1}{(\alpha + X)^2(\beta + Y)^2} \right] \Big|_{\mathbb{Q}} &= 0, \\
\int d\Lambda_{ab}^{\alpha\beta} \left[\frac{[W|\ell|Z]}{(\alpha + X)^2(\beta + Y)^2} \right] \Big|_{\mathbb{Q}} &= 0.
\end{aligned} \tag{B18}$$

The only other type of term in (A24) is

$$\int d\Lambda_{ab}^{\alpha\beta} \left[\frac{[X|\ell|q]^2}{(\beta + K_x)^2} \right] \Big|_{\mathbb{Q}} = -\frac{1}{6} \frac{[ab]}{\langle ab \rangle} \frac{[X|a|q]}{[a|\chi|a]} \left([X|a|q] \left(1 - 2 \frac{[b|\chi|b]}{[a|\chi|a]} \right) - 2[X|b|q] \right). \tag{B19}$$

The integrated non factorising contribution is thus (with $k = K_{ab}$)

$$\begin{aligned}
\mathcal{I}_{\text{n.f.}}^{\alpha-\beta+} &= -\frac{i}{6} \frac{[a b]}{\langle a b \rangle} \left[\frac{1}{3} [q|b + 2a|q] \frac{\langle c q \rangle}{[q|k|c]^2 [q|k|q]^2 \langle d e \rangle^2} \times \right. \\
&\quad \left(-\frac{[f c]^3 [q|k|c]^3}{t_{abc} [f|k|c]} + \frac{[e f] \langle d f \rangle [q|k|e]^3}{\langle c d \rangle \langle e f \rangle^2} - \frac{\langle c e \rangle [d c] [q|k|d]^3 [q|k|c]}{\langle c d \rangle^2 \langle e f \rangle [q|k|f]} \right) \\
&\quad + \left(\frac{1}{3} \frac{\langle d a \rangle}{\langle q a \rangle} [c|b + 2a|q] - [c|k|d] \right) \frac{[q|k|c]}{\langle c d \rangle^2 \langle d e \rangle \langle e f \rangle [q|k|f]} \\
&\quad - [q|2b + a|q] \frac{1}{[q|k|c] \langle d e \rangle^2} \times \\
&\quad \left(-\frac{[f c]^3 \langle q c \rangle [q|k|c]^2}{t_{\alpha\beta c} [f|k|c] [q|k|q]^2} + \frac{[e f] \langle d f \rangle \langle q e \rangle [q|k|e]^2}{\langle c d \rangle \langle e f \rangle^2 [q|k|q]^2} \right. \\
&\quad \left. - \frac{\langle c e \rangle [d c]}{\langle c d \rangle^2 \langle e f \rangle} \frac{[q|k|d]^2}{[q|k|f] [q|k|q]^2} \left(\langle q d \rangle [q|k|c] + \frac{\langle f c \rangle [q|k|q] [q|k|d]}{3 [q|k|f]} \right) \right) \\
&\quad - [f|2b + a|q] \frac{[f c]^2 [q|k|c]}{\langle d e \rangle^2 t_{abc} [f|k|c] [q|k|q]} - \frac{1}{3} [d|2b + a|q] \frac{[q|k|d]^3 \langle c e \rangle}{\langle c d \rangle^2 \langle d e \rangle^2 \langle e f \rangle [q|k|c] [q|k|f] [q|k|q]} \\
&\quad + \left(\frac{[f|k|q]}{[q|k|q]^2} \left(\frac{1}{3} [q|b + 2a|q] - 2 [q|k|q] \right) - \frac{1}{3} \frac{[f|2b + a|q]}{[q|k|q]} \right) \times \\
&\quad \frac{[f q]}{t_{cde}} \left(\frac{\langle q|k|c|c d \rangle}{\langle d e \rangle \langle q|k|K_{cd}|e \rangle} - \frac{[d e] [e f]}{\langle c d \rangle [f|k|c]} + \frac{[c e]}{\langle c d \rangle \langle d e \rangle} \right) \\
&\quad + \frac{[q|k|q]}{[q|k|f]} \frac{1}{\langle c d \rangle^2 \langle e f \rangle} \left(\frac{1}{3} \frac{1}{\langle q a \rangle^2} \frac{\langle a|K_{cd}|a|q \rangle}{\langle q|a|K_{cd}|e \rangle} \left(\langle a|K_{cd}|a|q \rangle \left(1 - 2 \frac{\langle q|b|K_{cd}|e \rangle}{\langle q|a|K_{cd}|e \rangle} \right) - 2 \langle a|K_{cd}|b|q \rangle \right) \right. \\
&\quad \left. - \frac{\langle a|K_{cd}|a|q \rangle}{\langle q|a|K_{cd}|e \rangle} \left(\frac{2(\langle c|b|c \rangle + [d|b|d]) - s_{cd}}{\langle q a \rangle} \right) \right) \\
&\quad + \frac{[c d] [c|K_{cd}|e]}{\langle e|K_{cd}|k|q \rangle \langle d e \rangle t_{cde}} \times \\
&\quad \left. \left(\frac{1}{3} \frac{[f|a|q]}{\langle q|a|K_{cd}|e \rangle} \left([f|a|q] \left(1 - 2 \frac{\langle q|b|K_{cd}|e \rangle}{\langle q|a|K_{cd}|e \rangle} \right) - 2 [f|b|q] \right) - (2 [f|a|q] - 3 [f|k|q]) \frac{[f|a|q]}{\langle q|a|K_{cd}|e \rangle} \right) \right) \Big].
\end{aligned} \tag{B20}$$

The $\mathcal{I}_{\text{s.b.}}$ piece

Finally, for the square bracket term:

$$\begin{aligned}\mathcal{I}_{\text{s.b.}}^{\alpha-\beta+} &= \int d\Lambda_{ab}^{\alpha\beta} \left[-\frac{i [q|\beta|q]^2 [q|\alpha\beta|q] [f k^b]^2}{3 [q|\alpha|q]^2 s_{\alpha\beta} [k^b q]^2 t_{cde}} \left(\frac{[k^b c][cd]}{\langle de \rangle [k^b |K_{cd}|e]} - \frac{[de][ef]}{\langle cd \rangle [f|k|c]} + \frac{[ce]}{\langle cd \rangle \langle de \rangle} \right) \right] \\ &= \int d\Lambda_{ab}^{\alpha\beta} \left[-\frac{\langle \alpha q \rangle^2 [q|\beta|q]^2 [q|\alpha\beta|q]}{\langle \beta q \rangle^2 [q|\alpha|q]^2 [k^b q]^2} \frac{1}{s_{ab}} A_5^{1\text{-loop}}(k^{b+}, c^+, d^+, e^+, f^+) \right].\end{aligned}\quad (\text{B21})$$

In this form this term can be summed with the other internal helicity configuration to give:

$$\mathcal{I}_{\text{s.b.}} = \mathcal{I}_{\text{s.b.}}^{\alpha-\beta+} + \mathcal{I}_{\text{s.b.}}^{\alpha+\beta-} = \int d\Lambda_{ab}^{\alpha\beta} \left[-\left(\frac{[q|\beta|q]^2}{[q|\alpha|q]^2} + \frac{[q|\alpha|q]^2}{[q|\beta|q]^2} \right) \frac{[q|\alpha\beta|q]}{[k^b q]^2} \frac{1}{s_{ab}} A_5^{1\text{-loop}}(k^{b+}, c^+, d^+, e^+, f^+) \right].\quad (\text{B22})$$

Using

$$\begin{aligned}\frac{[q|\beta|q]^2}{[q|\alpha|q]^2} &= 1 - 2 \frac{[q|k|q]}{[q|\alpha|q]} + \frac{[q|k|q]^2}{[q|\alpha|q]^2} \\ \frac{[q|\alpha|q]^2}{[q|\beta|q]^2} &= 1 - 2 \frac{[q|k|q]}{[q|\beta|q]} + \frac{[q|k|q]^2}{[q|\beta|q]^2},\end{aligned}\quad (\text{B23})$$

as the final term in each case corresponds to a cubic pentagon and

$$\frac{[q|k|q]}{[q|\alpha|q]} + \frac{[q|k|q]}{[q|\beta|q]} = \frac{[q|k|q]^2}{[q|\alpha|q][q|\beta|q]}\quad (\text{B24})$$

also leads to a cubic pentagon only the first term contributes:

$$\mathcal{I}_{\text{s.b.}} = \int d\Lambda_{ab}^{\alpha\beta} \left[-2 \frac{[q|\alpha\beta|q]}{[k^b q]^2} \frac{1}{s_{ab}} A_5^{1\text{-loop}}(k^{b+}, c^+, d^+, e^+, f^+) \right] + \text{transcendental functions}.\quad (\text{B25})$$

There is the obvious problem that quadratic terms in the numerator will be present, as the loop momenta are not adjacent to a λ_q :

$$\begin{aligned}[a|\ell|q][b|\ell|q][q|\alpha\beta|q] &\rightarrow [a|\ell + x_2 b|q][b|\ell - x_1 a|q][q|(\ell + (1 - x_1)a + x_2 b)K|q] \\ &\rightarrow \frac{\ell^2}{4} (([aq] + [bq])[q|K|q] + x_1 x_2 [ab]^2 \langle a q \rangle \langle b q \rangle) (1 - x_1 - x_2) [q|ab|q].\end{aligned}\quad (\text{B26})$$

The logarithmically divergent integral is captured by the cut-constructible piece and thus dropped. The remaining rational integral leads to

$$\mathcal{I}_{\text{s.b.}} \Big|_{\mathbb{Q}} = \frac{1}{3} \frac{1}{\langle ab \rangle} \frac{[qa][qb]}{[k^b q]^2} A_5^{1\text{-loop}}(k^{b+}, c^+, d^+, e^+, f^+), \quad (\text{B27})$$

which corresponds to the rational part of the one-loop $(+, +; -)$ splitting function [33].

$\mathcal{I}_{\text{d.p.}}^{\alpha+\beta-}$ and $\mathcal{I}_{\text{n.f.}}^{\alpha+\beta-}$ can be obtained from $\mathcal{I}^{\alpha-\beta+}$ using the reflection symmetry of the current

$$\mathcal{I}^{\alpha+\beta-}(a, b, c, d, e, f; q) = \mathcal{I}^{\alpha-\beta+}(b, a, f, e, d, c; q). \quad (\text{B28})$$

The final expression:

$$\mathcal{I}(a^+, b^+, c^+, d^+, e^+, f^+, g^+; q) = \mathcal{I}_{\text{d.p.}} + \mathcal{I}_{\text{s.b.}} + \mathcal{I}_{\text{n.f.}} \quad (\text{B29})$$

can then be divided by z and shifted to give the residues.

-
- [1] J. R. Andersen *et al.*, arXiv:1605.04692 [hep-ph].
 - [2] G. Heinrich, arXiv:1710.04998 [hep-ph].
 - [3] S. Caron-Huot, L. J. Dixon, A. McLeod and M. von Hippel, Phys. Rev. Lett. **117** (2016) no.24, 241601 doi:10.1103/PhysRevLett.117.241601 [arXiv:1609.00669 [hep-th]].
 - [4] R.J. Eden, P.V. Landshoff, D.I. Olive, J.C. Polkinghorne, *The Analytic S Matrix*, (Cambridge University Press, 1966).
 - [5] R. Britto, F. Cachazo, B. Feng and E. Witten, Phys. Rev. Lett. **94** (2005) 181602 [hep-th/0501052].
 - [6] Z. Bern, L. J. Dixon, D. C. Dunbar and D. A. Kosower, Nucl. Phys. B **425** (1994) 217 [hep-ph/9403226].
 - [7] Z. Bern, L. J. Dixon, D. C. Dunbar, D. A. Kosower, Nucl. Phys. **B435** (1995) 59 [hep-ph/9409265].
 - [8] S. Catani, Phys. Lett. B **427** (1998) 161 doi:10.1016/S0370-2693(98)00332-3 [hep-ph/9802439].
 - [9] E. W. N. Glover, C. Oleari and M. E. Tejeda-Yeomans, Nucl. Phys. B **605** (2001) 467 doi:10.1016/S0550-3213(01)00210-3 [hep-ph/0102201].
 - [10] Z. Bern, A. De Freitas and L. J. Dixon, JHEP **0203** (2002) 018 doi:10.1088/1126-6708/2002/03/018 [hep-ph/0201161].
 - [11] S. Abreu, F. Febres Cordero, H. Ita, M. Jaquier, B. Page and M. Zeng, Phys. Rev. Lett. **119** (2017) no.14, 142001 doi:10.1103/PhysRevLett.119.142001 [arXiv:1703.05273 [hep-ph]].
 - [12] S. Badger, H. Frellesvig and Y. Zhang, JHEP **1312** (2013) 045 doi:10.1007/JHEP12(2013)045 [arXiv:1310.1051 [hep-ph]].
 - [13] T. Gehrmann, J. M. Henn and N. A. Lo Presti, Phys. Rev. Lett. **116** (2016) 6, 062001 doi:10.1103/PhysRevLett.116.062001 [arXiv:1511.05409 [hep-ph]].
 - [14] D. C. Dunbar and W. B. Perkins, Phys. Rev. D **93** (2016) no.8, 085029 doi:10.1103/PhysRevD.93.085029 [arXiv:1603.07514 [hep-th]].
 - [15] D. C. Dunbar and W. B. Perkins, Phys. Rev. Lett. **117** (2016) no.6, 061602

- doi:10.1103/PhysRevLett.117.061602 [arXiv:1605.06351 [hep-th]].
- [16] Z. Bern, G. Chalmers, L. J. Dixon and D. A. Kosower, Phys. Rev. Lett. **72** (1994) 2134 doi:10.1103/PhysRevLett.72.2134 [hep-ph/9312333].
 - [17] E. Witten, Commun. Math. Phys. **252** (2004) 189 doi:10.1007/s00220-004-1187-3 [hep-th/0312171].
 - [18] Z. Bern, L. J. Dixon, D. C. Dunbar and D. A. Kosower, Phys. Lett. B **394** (1997) 105 doi:10.1016/S0370-2693(96)01676-0 [hep-th/9611127].
 - [19] Z. Bern, L. J. Dixon and D. A. Kosower, Nucl. Phys. B **412** (1994) 751 doi:10.1016/0550-3213(94)90398-0 [hep-ph/9306240].
 - [20] D. C. Dunbar, G. R. Jehu and W. B. Perkins, Phys. Rev. D **93** (2016) no.12, 125006 doi:10.1103/PhysRevD.93.125006 [arXiv:1604.06631 [hep-th]].
 - [21] R. Britto, F. Cachazo and B. Feng, Nucl. Phys. B **725** (2005) 275 doi:10.1016/j.nuclphysb.2005.07.014 [hep-th/0412103].
 - [22] D. C. Dunbar, W. B. Perkins and E. Warrick, JHEP **0906** (2009) 056 [arXiv:0903.1751 [hep-ph]].
 - [23] D. Forde, Phys. Rev. D **75** (2007) 125019 doi:10.1103/PhysRevD.75.125019 [arXiv:0704.1835 [hep-ph]].
 - [24] T. Cohen, H. Elvang and M. Kiermaier, JHEP **1104** (2011) 053 doi:10.1007/JHEP04(2011)053 [arXiv:1010.0257 [hep-th]].
 - [25] K. Risager, JHEP **0512** (2005) 003 doi:10.1088/1126-6708/2005/12/003 [hep-th/0508206].
 - [26] D. C. Dunbar, J. H. Eittle and W. B. Perkins, JHEP **1006** (2010) 027 [arXiv:1003.3398 [hep-th]].
 - [27] S. D. Alston, D. C. Dunbar and W. B. Perkins, Phys. Rev. D **92** (2015) 6, 065024 doi:10.1103/PhysRevD.92.065024 [arXiv:1507.08882 [hep-th]].
 - [28] D. C. Dunbar and W. B. Perkins, Phys. Rev. D **94** (2016) no.12, 125027 doi:10.1103/PhysRevD.94.125027 [arXiv:1601.03918 [hep-th]].
 - [29] C. Schwinn and S. Weinzierl, JHEP **0505** (2005) 006 doi:10.1088/1126-6708/2005/05/006 [hep-th/0503015].
 - [30] D. A. Kosower, Nucl. Phys. B **335** (1990) 23. doi:10.1016/0550-3213(90)90167-C
 - [31] S. Badger, G. Mogull and T. Peraro, JHEP **1608** (2016) 063 doi:10.1007/JHEP08(2016)063 [arXiv:1606.02244 [hep-ph]].
 - [32] Z. Bern, L. J. Dixon and D. A. Kosower, Phys. Rev. D **71** (2005) 105013 doi:10.1103/PhysRevD.71.105013 [hep-th/0501240].
 - [33] Z. Bern and G. Chalmers, Nucl. Phys. B **447** (1995) 465 doi:10.1016/0550-3213(95)00226-I [hep-ph/9503236].