



Queensland University of Technology
Brisbane Australia

This is the author's version of a work that was submitted/accepted for publication in the following source:

Mohd. Zamin, Bin Jumaat, [Kabir, Md Humayun](#), & Obaydullah, M (2010) Structural performance of reinforced concrete beams repairing from spalling. *European Journal of Scientific Research*, 45(1), pp. 89-102.

This file was downloaded from: <http://eprints.qut.edu.au/53264/>

Notice: *Changes introduced as a result of publishing processes such as copy-editing and formatting may not be reflected in this document. For a definitive version of this work, please refer to the published source:*

Structural Performance of Reinforced Concrete Beams Repairing from Spalling

Mohd. Zamin Bin Jumaat

*Professor, Dept. of Civil Engineering, Faculty of Engineering
University of Malaya, Kuala Lumpur, Malaysia*

E-mail: zamin@um.edu.my

Tel: +60193129194; Fax: +603-79675340

Md. Humayun Kabir

Senior Design Engineer (Civil), JEKS Engineering Sdn Bhd, Ampang, Selangor, Malaysia

E-mail: ripon94033@gmail.com

Tel: +60162677958

M. Obaydullah

Structural Engineer, HSSI Engineering Sdn Bhd, Kuala Lumpur, Malaysia

E-mail: m_obaydullah@yahoo.com

Tel: +60162677958

Abstract

The effectiveness of a repair work for the restoration of spalled reinforced concrete (r.c.) structures depends to a great extent, on their ability to restore the structural integrity of the r.c. element, to restore its serviceability and to protect the reinforcements from further deterioration. This paper presents results of a study concocted to investigate the structural performance of eight spalled r.c. beams repaired using two advanced repair materials in various zones for comparison purposes, namely a *free flowing self compacting mortar* (FFSCM) and a *polymer Modified cementitious mortar* (PMCM). The repair technique adopted was that for the repair of spalled concrete in which the bond between the concrete and steel was completely lost due to reinforcement corrosion or the effect of fire or impact. The beams used for the experiment were first cast, then hacked at various zones before they were repaired except for the control beam. The beam specimens were then loaded to failure under four point loadings. The structural response of each beam was evaluated in terms of first crack load, cracking behavior, crack pattern, deflection, variation of strains in the concrete and steel, collapse load and the modes of failure. The results of the test showed that, the repair materials applied on the various zones of the beams were able to restore more than 100% of the beams' capacity and that FFSCM gave a better overall performance.

Keywords: Reinforced Concrete, Reinforcement Corrosion, Spalling, Repair, Advanced Repair Materials, Bond, Structural Integrity

1. Introduction

Reinforced concrete is the most frequently applied structural material in the practice of civil engineering. By virtue of its good characteristics such as durability, compressive strength, hardness, fire resistance and workability, it is used in a wide variety of building and construction projects. As durable and strong as it is, the commonly held view that concrete is a maintenance-free construction material has been challenged in recent years. Several examples can be shown where concrete do not perform as well as it was expected. Deterioration in the form of spalling is very common in the concrete covers of r.c. structures, especially when they are exposed to aggressive environmental conditions. Spalling occurs most commonly because of corrosion in the reinforcement bars. Such corrosion is often accelerated by a lack of adequate cover. Spalling is also brought about by factors such as alkali-aggregate reactions, abrasion of the concrete surface/cover, the use of high-pressure water jets, damage from fire, and exposure to sulphates, sea-water and acid. Chloride ions and carbon dioxide play an active role in this scenario.

Carbonation occurs as a result of penetration of carbon dioxide from the atmosphere. In the presence of moisture this forms carbonic acid which reduces the alkalinity of the cement matrix. If the alkalinity falls below about pH 10, the passivating layer gets destroyed. As a result in the presence of oxygen and moisture, the steel starts to corrode. Chloride induced corrosion of reinforcement occurs principally in older structures or in those which are exposed to the chloride containing materials such as sea water or de-icing salts. Chloride ions penetrate the concrete cover and break down the protective oxide layer around the reinforcements, thus depassivating the steel and permitting corrosion. As the corrosion proceeds, it not only results in significant loss of cross-section of the reinforcement but also might cause the concrete cover to spall. While removing corrosion products it is necessary to measure the diameter of rebar. Replacement of steel is necessary if it has lost more than 20 percent of area but many specifies require replacement if more than 10 percent of the area is lost [1, 2, 3].

Repair of such deteriorated r.c. structures are normally carried out to restore the structural integrity, to reshape the defective structures and also to protect the reinforcement from further severe weather conditions. In recent years, the growing need to maintain and repair structures has brought about a definite variation in the expenditure for restoration compared to the investment for new structures. In the UK alone approximately £500 million is spent annually on repair and refurbishment [4]. It has been estimated that, at present, in Europe (and particularly in Italy) the investments in maintenance and repair work on old structures, represent about 50% of the total expenditure in construction. Some estimates have indicated that in 2010 the expenditure for maintenance and repair work will represent about 85% of the total expenditure in the construction field [5]. Presently in Malaysia, repairing works of civil structures (flyovers, bridges and marine structures) have been increasing significantly. This information, therefore, indicates the marked increase in repair and that this trend is likely to continue

Several types of new advanced repair materials as well as techniques have been successfully developed to reinstate the spalled cover of r.c structures. One such method is patch repair. Patching is normally done by applying mortar or concrete by hand, recasting with mortar or concrete, by using sprayed concrete, or by using ferrocement with mortar or concrete [6, 7, 8]. Generally the modified cementitious mortar or concrete are preferred in this field because the properties of these materials are similar to that of the parent concrete. In recent years, with the introducing of structurally effective bonding agents, patching using modified cementitious mortar has been used widely. Studies [5, 9-12] have been conducted to investigate the mechanical and physical properties of repair materials and to enhance their suitability for patch repairs. These studies have also shown that the use of a suitable durable material improves the function and performance of corroded structures, restores and increases their strength and stiffness, enhances their surface appearance, provides water-tightness and prevents the ingress of aggressive species at the steel surface.

Problems that are generally encountered in such repair works have been identified and possible solutions are presented in various specifications and guidelines. These include removal of unsound concrete, preparation of concrete bonding surfaces, cleaning and/or replacement of reinforcing steel, surface inspection, and, finally, the selection of right repair materials, depending on the severity of the existing damage and exposure conditions. A premature debonding failure is the major problem for the patch repair. It was found that, this failure had occurred due to less efficient bond [13] or due to mismatch of properties between repair materials and substrate concrete [14]. International Concrete Repair Institute [15] has shown some patterns of premature failure due to mismatch of properties of repair materials and mentioned the desirable properties of repair materials.

A number of studies have been carried out by several researchers [4, 8, 13, 14, 16-18] indicate that the structural performance of repaired r.c. structures is well-studied, the structural performance of r.c. structures repaired using advanced repair materials in various zones of flexurally loaded r.c. members in which the bond between concrete and steel have lost completely, has yet to be examined.

Therefore, this paper presents a study on the structural performance of r.c. beams repaired using two advanced patch repair mortars. Furthermore, this study focuses on the serviceability, strength and ductility performance for each repaired beam compare to control one to ascertain their potential application in spalled reinforced concrete beams

2. Experimental Programme

2.1. Test Specimens

A total of nine r.c. beams were prepared. All specimens were identical in their dimensions: they had rectangular cross-sections of 125 x 250 mm, concrete covers of 25 mm, stretched 2300 mm in length and had longitudinal reinforcements and stirrups up to the level of their shear span. Table 1 outlines the details of the test programme.

Table 1: Detail of Test Specimens

Type	Beam Code ^a	No	Designation	Spalling Zone	Repair Material
Type I	B1	1	Control	Not spalled	Un-repaired
Type II	RB2	1	Repaired	Whole length of bottom face	Sika Microconcrete 2000
	RB3	1			Sika MonoTop R40
Type III	RB4	1	Repaired	Maximum flexure zone	Microconcrete 2000
	RB5	1			Sika MonoTop R40
Type IV	RB6	1	Repaired	Maximum flexure zone plus shear zone (one end)	Sika Microconcrete 2000
	RB7	1			Sika MonoTop R40
Type V	RB8	1	Repaired	Shear zone (one end)	Sika Microconcrete 2000
	RB9	1			Sika MonoTop R40

^a'R' designates repaired beam.

Table 2: Properties of Repair Materials

Repair Materials	Type	Expansion/ Shrinkage	Compressive strength (N/mm ²)		Flexural strength (N/mm ²)	Bond on concrete (N/mm ²)	Modulus of elasticity (N/mm ²)
		%	7 days	28 days	28 days		
Sika Microcrete 2000	Pre-bagged concrete grey powder	0.2% at 28 days	>50	>70	>7	>1.5 with bonding agent	~26000
Sika MonoTop R40	Pre-bagged concrete grey powder	Non Shrink	>30	>40	>7	>1.5 with bonding agent	~20000
Sika MonoTop 610 (Bonding Agent)	Pre-bagged grey powder		>30	45 to 55	5.5 to 7.5	2 to 3	~20000

2.2. Materials

Ordinary Portland cement, pit sand and natural crushed stone of a maximum aggregate size 20 mm were used in the weighted proportion: 1.50:3.45:2.40. A water-cement ratio of 0.65 was used to bring about the concrete's desired strength of 30 MPa. Standard samples of cube, prism and cylinder were used to determine the concrete's compressive strength, modulus of rupture and Young's modulus of elasticity at the desired age of 28 days.

The repair materials chosen for the study are Sika Microcrete 2000 and Sika MonoTop R40. Both are shrinkage-compensated cementitious mortars that are also pre-packed, single component systems ready for use. Sika Microcrete 2000 is a free flowing self compacting mortar (FFSCM) containing natural aggregate of a maximum size of 6 mm, while the MonoTop R40 is a polymer-modified cementitious mortar (PMCM) containing silica fume and fibre. For both materials, a prepacked grey powder called Sika MonoTop 610 was used as a bonding agent on the interface between the concrete substrate and the repair materials. The properties of the repair materials are listed in Table 2.

2.3. Specimens Preparation

The test specimens were cast under the same conditions and were crafted using similar workmanship. They were designed in accordance with British code BS 8110 [19] and American concrete institute code ACI 318-99 [20]. More specifically, the flexural reinforcements consisted of two high-yield deformed bars 12 mm in diameter and a characteristic strength of 551 N/mm^2 , two mild steel rebars of 10 mm diameter were used as hangers, while mild steel rebars of 6 mm in diameter and with an average characteristic strength of 520 N/mm^2 were used as stirrups at a spacing of 75 mm c/c as shown in Figure 1. The reinforcements were chosen to ensure a flexural failure mode. The concrete was then placed in steel moulds, compacted by a poker vibrator and demoulded after 7 days. The beams were cured by covering them with wet Hessian cloths for at least two weeks. They were finally air cured at ambient indoor laboratory conditions until the time came to repair them. After the 28th day of curing, specimens of Types II and V were intentionally made to spall in various zones by a process of mechanical chipping up to a depth of 75-80 mm in various zones as shown in Figures 2 and 3.

Figure 1: Fabrication of Beam

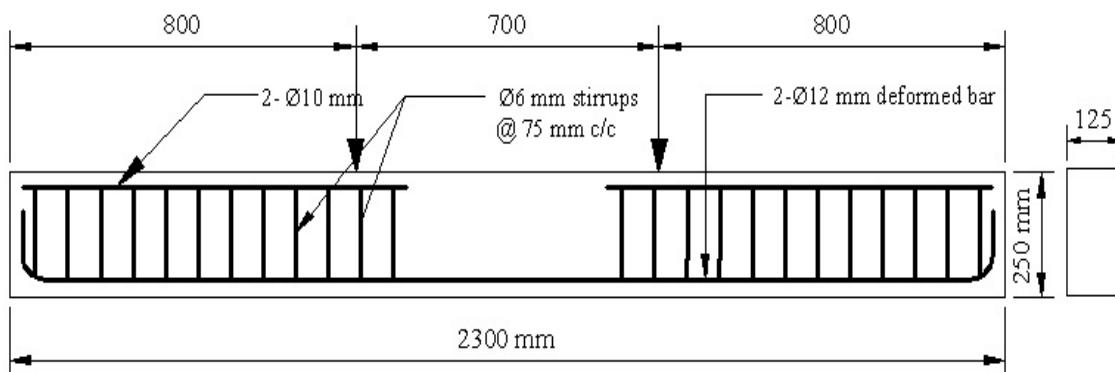

Figure 2: Test Specimens Showing Repair Zones

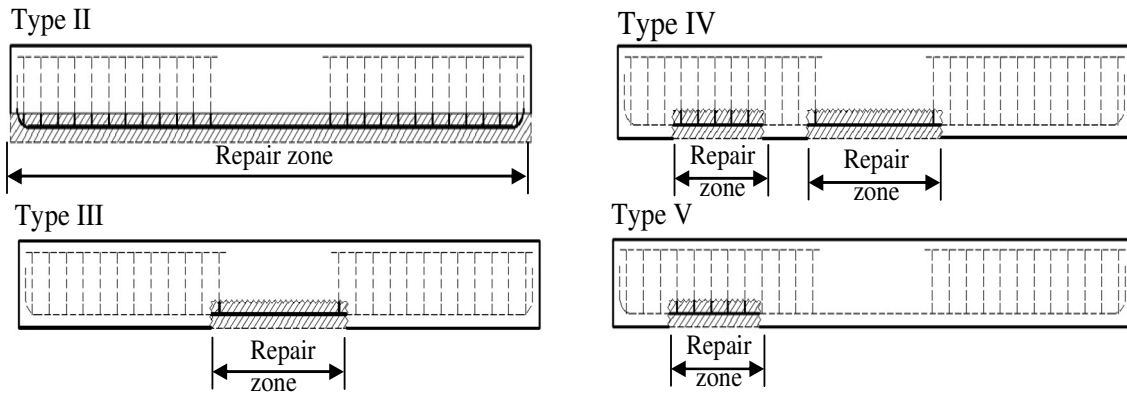
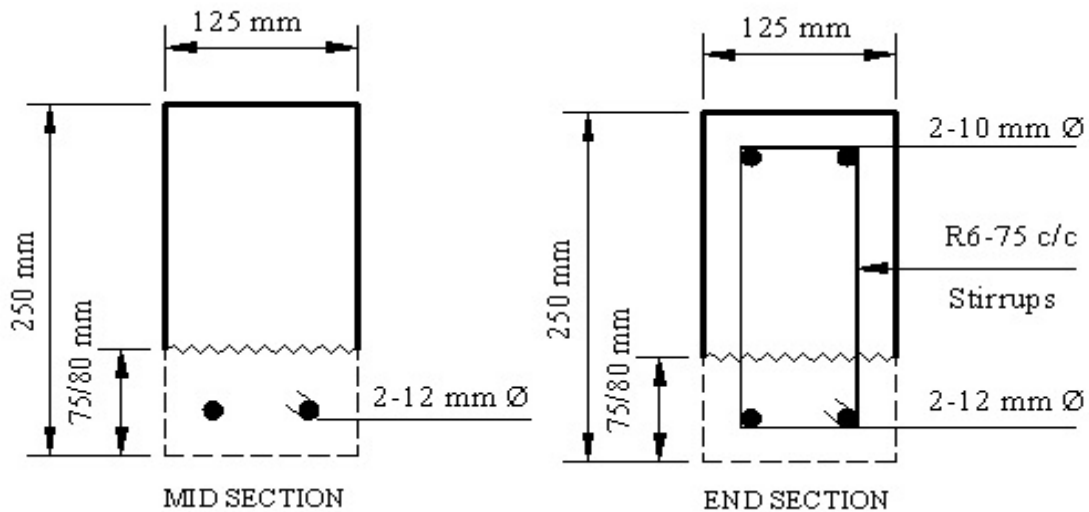

Figure 3: Typical Spalled Sections



2.4. Repair of Beam Specimens

2.4.1. Surface Preparation

Loose and unsound concrete in the various spalling zones along the length of the reinforcement beam were cut away by means of a steel chisel. The resulting grit and dust were removed by means of a wire brush, air blower and water jet as shown in Plate 1(a).

Plate 1: a) Surface Preparation b) Application of Sika Microcrete 2000 to Beam Surface and c) Sika MonoTop R40 on wet surface



2.4.2. Application of Sika Microcrete 2000 (FFSCM) to Beam Specimens

Wooden formworks were used in both repair works to give the repaired areas their desired shape. A few hours prior to the repair work, the substrate was properly saturated by filling the formwork with clean water. The water was then drained just prior to the commencement of the repair work and the formwork was made leak proof by the free-flowing nature of the Sika Microcrete 2000 material. The Sika Microcrete 2000 was mixed with clean water to a trowelable consistency as recommended by the manufacturers. Sika MonoTop 610 was then applied on the surface of steel and parent concrete as a bonding bridge before the repair material was applied. Three layers of micro-concrete, each of maximum thickness 25 mm were applied by pouring, in the method shown in Plate 1(b). Proper compaction was carried out to remove air voids by hammering and shaking sticks in each layer.

2.4.3. Application of Sika MonoTop R40 (PMCM) to Beam Specimens

The prepared substrate was soaked thoroughly with clean water until it was uniformly saturated and no surface water was present. The steel reinforcements were made rust free and primed with two coats of Sika MonoTop 610. This material was then applied on the surface as a bonding bridge before the repair material was applied. The Sika MonoTop R40 (PMCM) was mixed to a trowelable consistency with the addition of clean water and “wet-on-wet” work was then performed on the bonding bridge as shown in Plate 1(c). Since the thickness limitation of each application layer was 35 to 40 mm, two such layers of MonoTop R40 were applied in order to get the required 75 mm thickness. Proper compaction was carried out at each layer to remove air voids.

As soon as the mortar had hardened, the exposed surface was cured with Antisol-E curing compound. The formworks were removed after three days and the repaired areas were again cured with the same compound before being left to air-cure at ambient laboratory conditions until testing.

2.5. Experimental Procedure

Tests were conducted using a 500 kN, servo-controlled Instron Universal Testing Machine. The beam specimens were simply-supported on two rectangular rubber pads (30 mm thick) and loaded in flexure under a two points loading conditions. The position of the loads and the set-up of the machine are shown in Figure 4. The beams were loaded incrementally and the first crack loads, mid-span deflections, strains in steel and concrete, maximum crack widths, total number of cracks and failure modes were recorded accordingly.

Figure 4: Experimental Setup

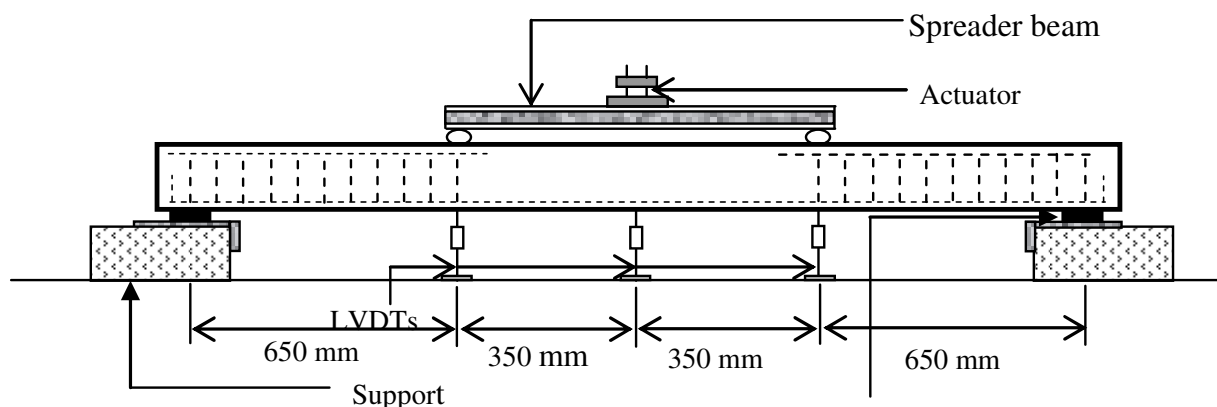

3. Test Results and Discussions

3.1. Cracking Load

The first crack in all the beams formed approximately 10 to 50 mm from the center line at the region of maximum moment. This implies that the steel reinforcement yielded at the same region. The first cracking loads for all beam specimens are listed in Table 3. The first crack of the control beam was 14.1 kN while the first cracking loads (P_{cr}) for the repaired beam specimens RB2, RB3, RB4, RB5, RB6, RB7, RB8 and RB9 were observed to be 10.0, 14.3, 14.0, 15.0, 11.0, 12.9, 14.3 and 15.0 kN respectively. All the beams repaired with the PMCM and beams RB4 and RB8 that were repaired using FFSCM had cracking loads that varied only slightly from the cracking load of the control beam. These occur even though there are differences in the location of the repair zones and repair materials for each beam and the results were similar to those reported for more conventional repair methods by Andrews [8]. The slight variation displayed in the results appears to be due to the variation in the concrete's modulus of rupture as well as in the repair materials. Only two beams, namely RB2 and RB6 (repaired using FFSCM), exhibited cracking loads 29% and 22% lower than that of the control beam respectively. These results suggest that the repair materials gained a lower modulus of rupture values than other beams. Although perfect bonding was achieved between the concrete substrate, steel and repair materials, the lower values may be attributable to poor mixing and inadequate curing. However, it should be pointed out that since the first crack is usually very sudden and may remain invisible for a certain period of time, the values recorded might not exactly be the same with the actual first crack loads.

Table 3: Test Results

Beam Code ^a	First Crack Load (kN)	Failure Load (kN)	First Crack Moment (kN-m)	Ultimate Moment (kN-m)	First Crack Load Ratio	Failure Load Ratio	Crack no. at Failure	Failure Mode
	P_{cr}	P_u	M_{cr}	M_u	Repair/Control	Repair/Control		
B1	14.10	80.60	5.30	26.90	1.00	1.00	11	Flexure Failure
RB2	10.00	84.60	3.95	28.20	0.70	1.05	15	Flexure failure with no debonding
RB3	14.30	81.20	5.35	27.10	1.00	1.00	11	Flexure failure with no debonding
RB4	14.00	95.80	5.25	31.85	1.00	1.20	15	Flexure failure with no debonding
RB5	15.00	84.65	5.60	28.20	1.05	1.05	13	Flexure failure with no debonding
RB6	11.00	80.80	4.30	26.95	0.78	1.00	11	Flexure failure with no debonding
RB7	12.90	81.50	4.90	27.20	0.92	1.00	11	Flexure failure with no debonding
RB8	14.30	84.20	5.35	28.10	1.00	1.05	10	Flexure failure with no debonding
RB9	15.00	83.00	5.60	27.70	1.05	1.03	10	Flexure failure with no debonding

^a'R' designates repaired beam.

3.2. Failure Load

Table 3 shows the failure load of all the beams. It can be seen that the ratio of the ultimate load capacity of the beams RB2, RB4, RB6 and RB8 repaired using FFSCM to that of control beam are 1.05, 1.20, 1.00 and 1.05 respectively. While the ratio of the ultimate load capacity of beams RB3, RB5, RB7 and RB9 repaired using PMCM to that of the control beam are 1.00, 1.05, 1.00, 1.03. These results indicate that the repair techniques performed using FFSCM and PMCM repair materials restored the beams to their full capacity compared with the control beam in terms of short-term structural efficiency. The proper surface preparation, unique bonding between the interfaces of concrete substrate and repair materials and the good quality of repair materials attributed to the restoration of full capacity of the defective beams. The level to which the ultimate load capacity was restored for beam specimens RB2 to RB9 is in agreement with the results reported by Nounu [4] and Andrews [8]. The theoretical values of the ultimate load for all beams were well within the satisfactory range, as shown in Figure 5(a).

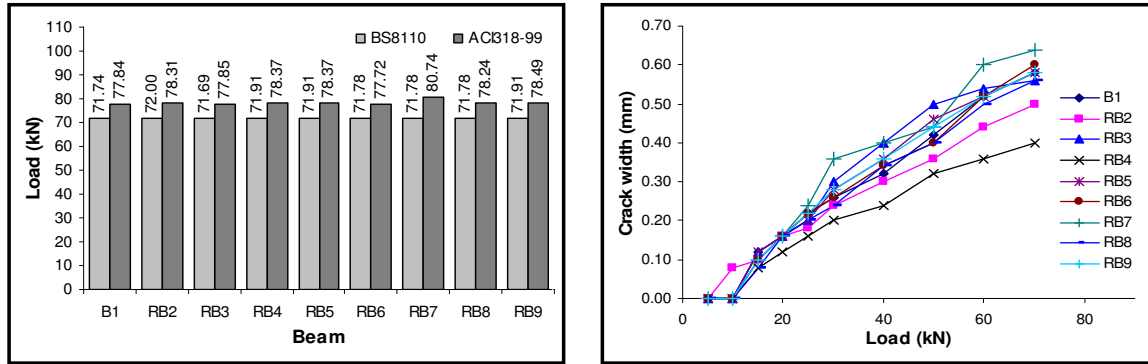
Figure 5: a) Theoretical Values of Ultimate Load and b) Maximum Crack Width-Load Curves for all Beams

3.3. Cracking Behavior

The cracking behavior of a reinforced concrete (r.c.) beam can be analyzed by considering the maximum crack width, the total number of cracks, relationship of crack width to the increasing load and tensile strain of steel and the pattern of cracks. Table 3 shows the total number of crack of all the beam specimens at failure load and the relationship between maximum crack width and increasing applied load are shown in Figure 5(b). It is seen that the crack widths for all beams increase linearly up to the recorded value of 70 kN load.

The FFSCM repaired beams RB2 and RB4 showed a higher number of cracks at failure and finer cracks trend among all the beams. This is in agreement with most recorded findings on concrete behavior that is when more cracks are present; the width of crack will substantially be reduced. The increase in the crack number in these two beams (RB2, RB4) may have been a result of the superior bond between the chosen repair materials and the steel of the beam. As the occurrence of cracks is directly related to concrete surface strain, the increase in the crack number could also be a consequence of the uniform distribution of the strain from steel to concrete surface.

Although beams RB6 and RB4 were repaired using the same material, the former was repaired over a more extensive area than the latter. Despite this, RB6 displayed fewer cracks. This variation could be due to the presence of four vertical joints and the less efficient bond between the vertical interfaces of the concrete substrate and the repair materials. It could also be that the bonding areas were not sufficiently wide to resist cracks along these interfaces, thus reducing the stiffening effect of the beam. This assumption may be more applicable to beam RB7, which was repaired using PMCM, than beam RB5, which was repaired using same material. Beams RB3, RB6, RB7, RB8 and RB9 behaved similarly to the control beam in terms of crack number. All the repaired beams as well as the control beam showed almost similar crack pattern as shown in Plate 2.

Fig. 6(a) shows the maximum crack width for all beams at service load and. Compared to the control beam, the beams repaired with FFSCM, namely beams RB2 and RB4, show smaller width of cracks. It can also be seen that the repaired beams RB3, RB5, RB7 and RB8 have the crack width differs by a small extent than that of the control beam, while the crack width of beam RB6 and RB9 are similar to that of the control beam. This small variation in crack width can probably be attributed to the variations in the number of cracks, the position of repair zone, the tensile strain of the steel bars, the thickness of the cover, the bond characteristics of the reinforcement, the distribution of the reinforcements, the diameter of the steel bar used, the distribution of the strain from the steel to the concrete surface, the bonding of the repair materials with steel and concrete and the erroneous reading of crack widths.

Figure 6(b) shows that the crack widths for all beams increase linearly with increasing steel strain, which is in agreement with the assumptions reported by Broms [21]. He mentioned that the average crack width increased linearly with increasing thickness of concrete cover and with increasing steel strain. Beams RB4 and RB9 shows less strain compared with the other beams.

Figure 6: a) Maximum Crack Widths at Service (25 kN) Load and b) Crack Width-Steel Strain Relationship

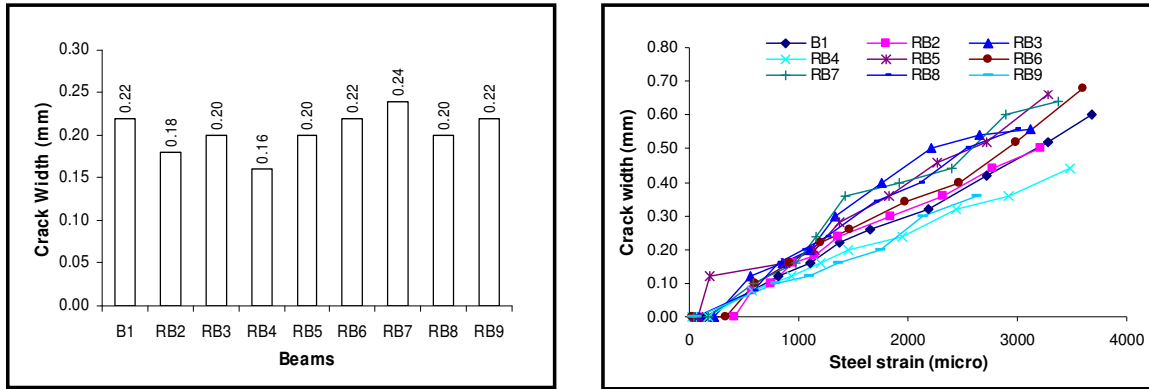

The ACI code specifies that at service load, the limiting crack width should be 0.40 mm for interior members and 0.32 mm for exterior member. In this study, all the repaired beams as well as control beams showed lesser value of crack width than that of allowable limit for exterior and interior member.

3.4. Mid-Span Deflections

The load-deflection curves for beams repaired with FFSCM and PMCM, as well as for the control beam, are shown in Figure 7(a). The actual maximum deflections at mid-span were measured and plotted against actual loads. The beam specimens repaired using FFSCM and PMCM showed almost similar load-deflection curves to that of the control beam. As stiffness and ductility are directly related to deflection, it appears that all the repaired beams are equally capable of restoring their full stiffness and exhibit similar ductile behavior as the control beam.

Figure 7(b) shows the maximum deflection of all the beams at first crack load and service load. The deflections of all the repaired beams at first crack and service load are similar to that of the control beam, with all showing almost the same deflection trend.

Figure 7: a) Load-Deflection Curves and b) Maximum Deflections at First Crack and Service Load for Beams 1-9

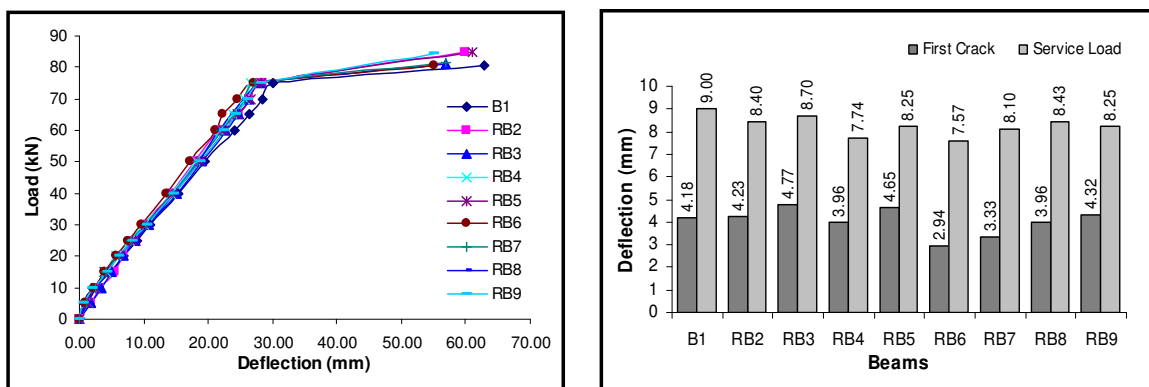

It was observed during the test that the rubber supporting pads (30 mm thick) had deflected about 4 to 5 mm at service load 25 kN. After deducting 4 mm from the value of the deflection at service load, the repaired beams RB2, RB3, RB4, RB5, RB6, RB7, RB8 and RB9 were 55.00%, 58.75%, 46.75%, 53.13%, 44.63%, 51.25%, 55.38% and 53.13% lower than the allowable deflection (span,2000 / 250=8mm) as recommended in British code BS 8110 [19]. The control beam's deflection was found to be about 62.50% lower than the allowable limit.

3.5. Strain Distribution

3.5.1. Concrete Strain

Electrical resistance strain gauges were used to monitor the variation of maximum compressive strains on the top surface with loads as shown in Figure 8(a). The curves of all the beams feature a relatively straight portion, reaching the maximum strain of about 2000 (micro). Compression failures in the concrete were observed to occur when the concrete strains achieved a value between 2500 to 4000 (micro). These findings are in agreement with that of the assumptions provided by ACI 318-99 [20].

Figure 8(b) represents the concrete maximum compressive strain for all beam specimens when the applied load is 70 kN (near the failure load of the control beam). The strains observed on the repaired beams RB2, RB3, RB4, RB5, RB6, RB7, RB8, and RB9 were compared with that of the control beam at a 70 kN load and differences of -13.75%, -15.15%, -23.15%, -8.60%, -1.60%, +6.15%, -2.55% and +3.15% were observed respectively. These results are compatible with the strain in the original beam.

Figure 8: a) Load-Concrete Compressive Strain Curves and b) Concrete Maximum Compressive Strain at 70 kN Load for all Beams

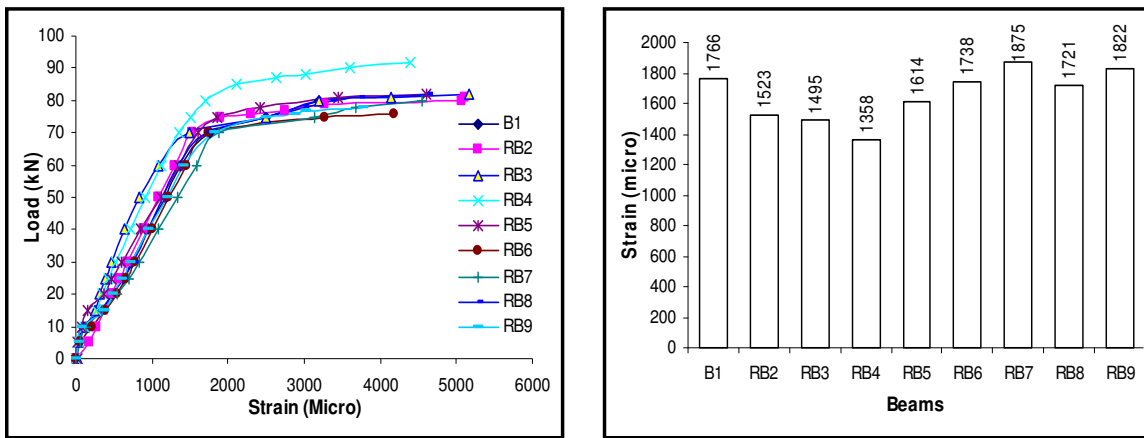

Figure 9: a) Location of Neutral Axis at 20 kN Load and b) Location of Neutral Axis at 70 kN Load

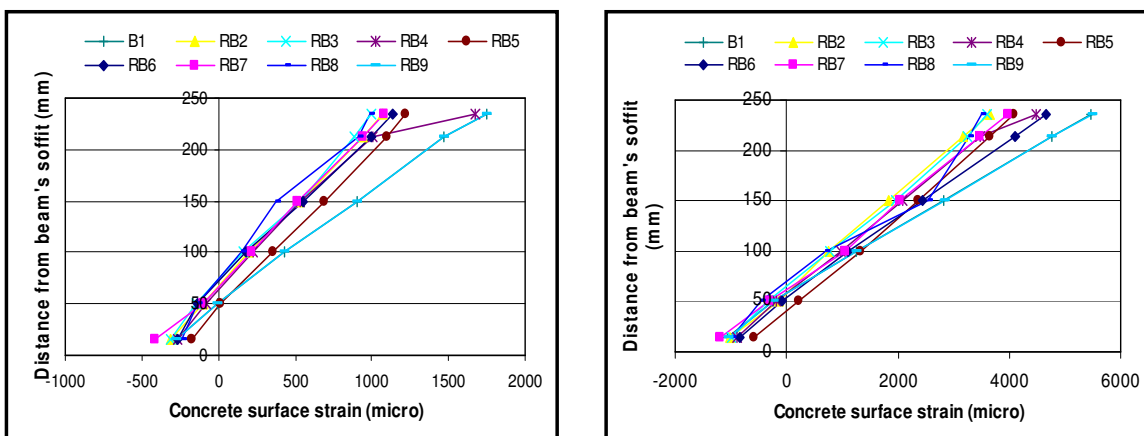

Table 4: Theoretical and Experimental Values for Neutral Axis

Beam Code ^a	Theoretical	Experimental (average)
	MM (from beam's aoffit)	
B1	60.19	62.50
RB2	58.24	62.50
RB3	60.61	62.50
RB4	59.00	62.50
RB5	59.00	62.50
RB6	59.79	62.50
RB7	59.70	62.50
RB8	59.79	62.50
RB9	59.00	62.50

^a'R' designates repaired beam.

During the test, it was observed that the neutral axis of all the beam specimens were shifting up as the load applied increased. The locations of neutral axis for two specified loads are shown in Figures 9(a) and 9(b). These results were compared with theoretical values calculated using the triangular stress method for measuring cracked sections as shown in Table 4.

3.5.2. Steel Strain

The strain in the reinforcing bars was monitored using electrical resistance gauges mounted on the longitudinal reinforcements that were placed in the centre of the high moment region. The relationship between the load and the tensile strain of the steel at the mid section of all the repaired and control beams is shown in Figure 10(a). The tension reinforcements of all the repaired beams started to yield at loads ranging between 70 to 80 kN. However, the reinforcements of the control beam and beam RB9 did not show any yield as the strain gauges did not provide any readings after a certain load. Nevertheless, the sudden crushing of concrete in the compression zone and the faster widening of central cracks just before failure were evidence of failure due to the yielding of reinforcements of the control beam and the repaired beam RB9. It was observed that the tensile strain of the steel increased with the increasing load, rising abruptly just before the beams failed.

Figure 10(b) shows the tensile maximum strains measured at service (25 kN) load for all repaired and control beams. The strain of the repaired beams RB2, RB3, RB4, RB5, RB6, RB7, RB8, and RB9 were found to differ from the control beam by -17%, -20%, -13%, -17%, -13%, -16%, -24% and -1% respectively. Thus, it can be said that the tensile strain registered at service load in the repaired beams is lower to that of the original beam.

Figure 10: a) Load-Steel Tensile Strain Curves and b) Steel Maximum Tensile Strain at 25 kN Load for all Beams

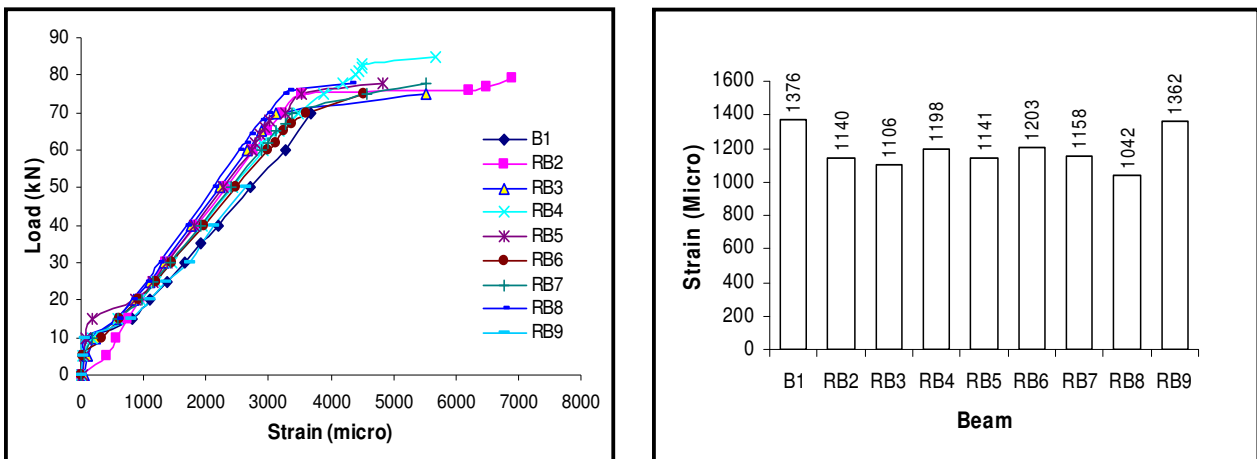

3.6. Failure Modes and Crack Patterns

Plate 2 shows the crack pattern and failure modes of the beam specimens. The tests were carried out by increasing the load until failure. A single mode of failure, namely, flexure failure, was noted for all the repaired beams as well as for the control specimen, and this observation is in agreement with the theoretical assumptions. Almost similar modes of failure were observed in beams RB2 to RB9 and in the control beam, as indicated by the crack patterns. As the load was increased to the point of failure, no debonding was observed along the horizontal surface of the concrete-mortar interfaces. This observation can be attributed to efficient bonds at both the concrete-steel and repair material-steel-concrete interfaces.

Plate 2: Failure Modes and Crack Patterns and for all Beams

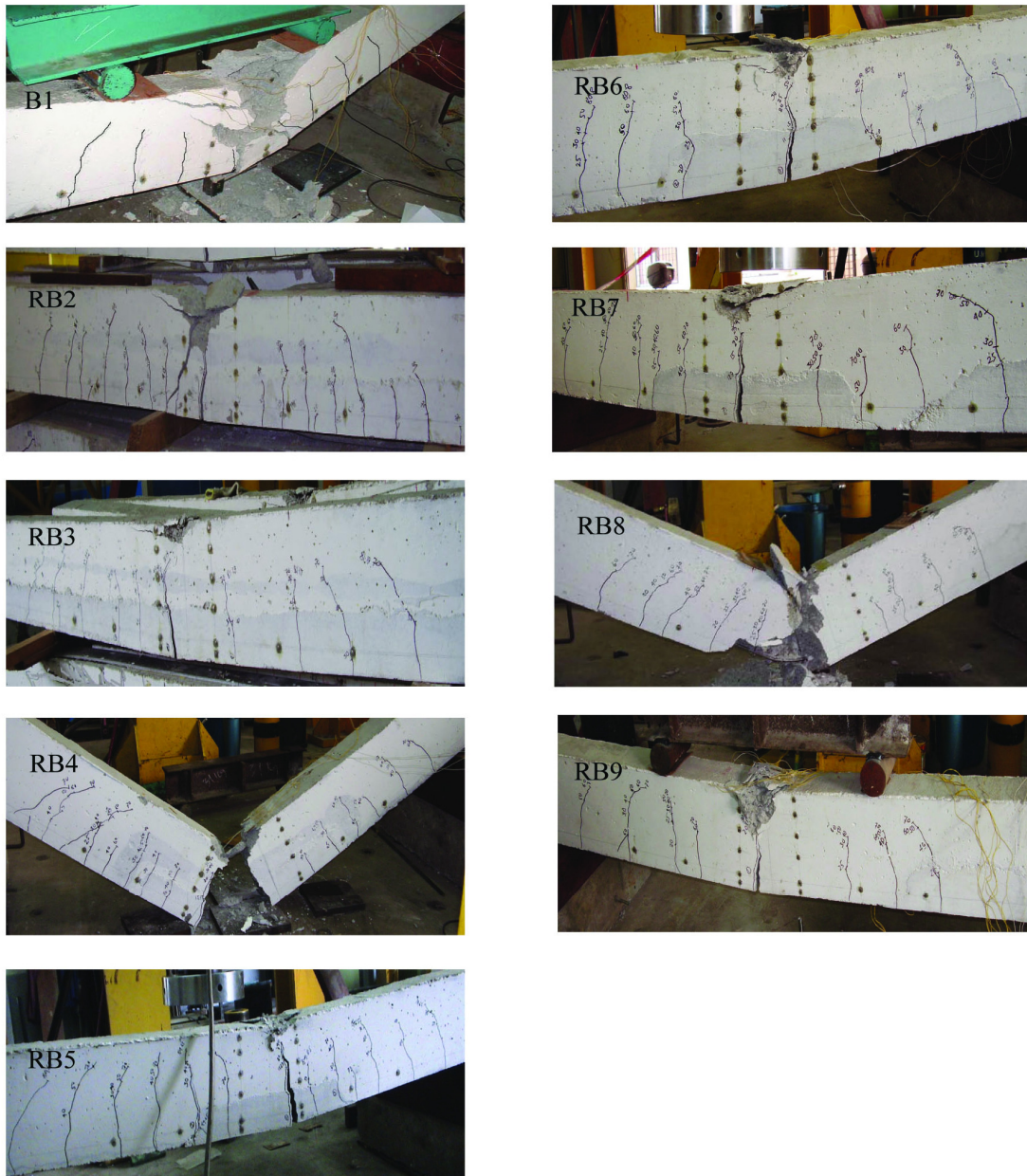

To summarize the findings, the failure was characterized by the gradual propagation of flexural cracks with the widening of a major central crack, the sudden crushing of concrete in the compression

zone just above the major crack, and the absence of debonding along the horizontal surface of the concrete-mortar interfaces

3.7. Effect a Position of Repair Zones

In general, it can be said that the position of a repair zone had no effect on the load at which the first crack appeared, the material's ability to restore the ultimate load, the ductility, and distribution of steel strain, crack patterns and failure modes of the bars.

4. Concluding Remarks

The conclusions that can be drawn from this study are,

- 1) The performance of the beams repaired in various zones using Free Flowing Self Compacting Mortar (FFSCM) and the Polymer Modified Cementitious Mortar (PMCM) was similar to the control beam in terms of first crack load.
- 2) All the repaired beams showed crack patterns similar to that of the control beam. At the service load, only the two beam specimens repaired using FFSCM, RB2 and RB4, showed better performance in terms of the crack width.
- 3) When applied across various zones, the FFSCM and PMCM restored the ultimate load carrying capacity of the beams to levels equal or above that of the control beam. All the beams, including the control, showed higher ultimate load values than that expected from theory.
- 4) The beam specimens repaired using FFSCM and polymer PMCM behaved similarly to the control beam in terms of strength, stiffness and ductility performance. It follows then that the repair materials and techniques used can be safely adopted to retrofit reinforced concrete beams that have spalled.
- 5) The beam specimens repaired using two repair materials did not differ significantly from the control beam in terms of concrete compressive and steel tensile strains.
- 6) The FFSCM and PMCM repaired beams had ductile modes of failure that was largely similar to that of the control beam. Failure occurred near the center of all the repaired beams and there was no debonding along the horizontal surface of the concrete-mortar interfaces as the load was increased to the point of failure.
- 7) The treatment used at the interfaces between the concrete and steel, and between the repair material, the steel and the concrete was more than satisfactory.
- 8) The position of the repair zone in general had no effect on the strength properties of the beams.

5. Acknowledgement

The authors would like to thank the, Majlis Penyelidikan Kebangsaan Sains Negera under IRPA 03-02-03-0216 for providing the fund to carry out the work reported in this paper. The authors would also like to thank Sika Kimia Sdn. Bhd., Malaysia for providing the repair materials and technical supports. The authors would also like to express their gratitude to whomsoever had contributed to their work either directly or indirectly.

References

- [1] Concrete Society and International Concrete Repair Institute, 2000, "Diagnosis of deterioration in concrete structures", Concrete Repair Manual 2nd edn; Vol.1, p.988-1027. Published jointly by ACI International, Building Research Establishment, 2003.
- [2] Tham, K.W., 1992. "Durability of Concrete Structures", Continuing Educational Workshop on Rehabilitation and Repair of Structures, IEB, Malaysia.
- [3] Cambel – Allen D. and H. Roper, 1991. "Concrete Structures: Material, Maintenance and Repair", Concrete Design and Construction Series, Longman Publishers (Pte) Ltd. Singapore.

- [4] Nounu G and Chaudhary Z., 1999. "Reinforced Concrete Repairs in Beams", Construction and Building Materials, Vol. 13, pp. 195-212.
- [5] Choppola L., "Concrete Durability and Repair Technology", ENCO Engineering and Concrete Spresiano (TV).
- [6] ACI International, BRE, Concrete Society and ICRI, 2003. "Guide to the Maintenance, Repair and Monitoring of Reinforced Concrete Structures", Concrete Repair Manual, 2nd Edn, Vol. 1, pp. 691-736.
- [7] Rutenbeck T., 1999. "Repairing Concrete with Shotcrete", Bureau of Reclamation, TSC, Civil Engineering Services, Metal Engineering and Research Laboratory, Denver, Colorado, R -90-10.
- [8] Andrews G, Sharma AK., 1998. "Repaired Reinforced Beams", Concrete International: Design and Construction; ACI, Vol. 10, No. 4, pp. 47-51.
- [9] Almusallam A.A., A.S. Al-Gahtani, M .Maslehuddin, M.M. Khan and A.R. Aziz., 1997. "Evaluation of Repair Materials for Functional Improvement of Slabs and Beams with Corroded Reinforcement", Proceedings of the Institution of Civil Engineers, Structures and Buildings, Vol. 122, pp. 27-34.
- [10] Almusallam A.A, A.S. Al-Gahtani, A.R. Aziz and Rasheeduzzafar, 1996. "Effect of Reinforcement Corrosion on Bond Strength", Construction and Building Materials, Vol. 10, No. 2 pp. 123-129
- [11] Emberson N.K and G.C. Mays, 1996. "Significant of Property Mismatch in the Patch Repair of Structural concrete; Part 1: Properties of Repair Systems", Magazine of Concrete Research, Vol. 48, No.174, pp. 45-57.
- [12] Marrosszky M, J.G. Yu and C.M. Ng, 1991. "Study of Bond in Concrete Repairs", Proceedings of the Second CANMET, ACI International Conference on Durability of Concrete, Montreal, Canada, ACI-SP Vol. 126, No. 70, pp. 1331-1354.
- [13] Ong B.G., 1993. "Performance of Repaired Reinforced Concrete Slabs", Master of Engineering Thesis, Department of Civil Engineering, National University of Singapore.
- [14] Emberson N.K. and G.C. Mays, 1996. "Significant of Property Mismatch in the Patch Repair of Structural Concrete; Part 3: Reinforced Concrete Members in Flexure", Magazine of Concrete Research, Vol. 48, No. 174, pp. 45-57.
- [15] International Concrete Repair Institute, 1996, "Guide for Selecting and Specifying for Repair of Concrete Surfaces", Concrete Repair Manual, 2nd edn., Vol.1., p.835-912, Published jointly by ACI International, Building Research Establishment, Concrete Society and International Concrete Repair Institute, 2003.
- [16] Austin SA and P.J. Robins, 1993. "Development of Patch Test to Study Behaviours of Shallow Concrete Patch Repairs", Magazine of Concrete. Research, Vol. 45, No. 164, pp. 221-229.
- [17] Cairns J., 1993." Load Relief During Structural Repairs to Reinforced Concrete Beams", Proceeding of the Institute of Civil Engineers, Structures and Building, Vol. 99, pp. 417-427.
- [18] Marrosszky M and Y. Yuan, 1991. "Major Factors Influencing the Performance of Structural Repair", Proceedings of ACI International Conference on Evaluation and Rehabilitation of Concrete Structures and Innovation in Design, Hong Kong, ACI-SP 128-50, vol. 2, pp. 819-837.
- [19] British Standard Institution, 1985. "Structural Use of Concrete", Part 1 and Part 2: London: BSI, BS 8110.
- [20] American Concrete Institute, 1999. "Building Code Requirements for structural Concrete", MI 4833-9094, ACI 318-99.
- [21] Broms B.B. and L.A. Lutz, 1965. "Effects of Arrangement of Reinforcement on Crack Width and Spacing of Reinforced Concrete Members", ACI Proceedings, ACI Journal, Vol. 62. No. 11, pp. 395-1409.