

QUT Digital Repository:
<http://eprints.qut.edu.au/>



This is the accepted version of this conference paper. Published as:

A. Boora, Arash and Zare, Firuz and Ghosh, Arindam (2009) *Application of Dynamic Hysteresis Band Height Control to Improve Output Voltage Transient in Boost and Positive Buck-Boost Converters*. In: Proceedings of the 13th European Conference on Power Electronics and Applications, 8-10 September 2009, Palau de Congressos, Barcelona.

© Copyright 2009 Please consult the authors

Application of Dynamic Hysteresis Band Height Control to Improve Output Voltage Transient in Boost and Positive Buck-Boost Converters

Arash A. Boora*, Firuz Zare, Senior Member IEEE, Arindam Ghosh, Fellow IEEE
Queensland University of Technology
Gardens Point, 2 George St, 4001, QLD Australia
arash.boora@student.qut.edu.au

Acknowledgement

The authors thank the Australian Research Council (ARC) for the financial support for this project through the ARC Linkage Grant LP0774899.

Keywords

Power Electronics, DC Power supply, Control methods for electrical systems.

Abstract

This paper presents dynamic hysteresis band height control to reduce the overshoot and undershoot issue on output voltage caused by load change. The converters in this study are Boost and Positive Buck-Boost (PBB) converters. PBB has been controlled to work in a step up conversion and avoid overshoot when load is changed. Simulation and experimental results have been presented to verify the proposed method.

Introduction

One of main approaches to control a Boost converter is to have a fast current control loop and a slower voltage reference loop [9, 10]. The output voltage loop changes the current reference according to output voltage error. The function, which transfers the voltage error to current reference, determines the control method. Hybrid control strategy based on state trajectory approximation and input to output transfer functions of a boost converter controlled by peak current mode control are addressed in [9] and [10].

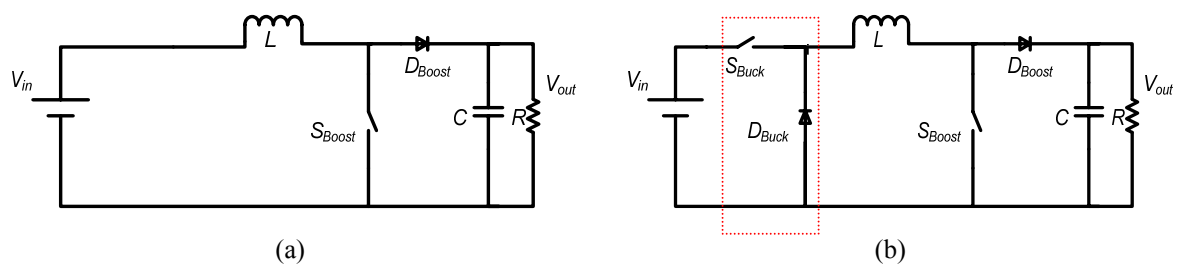

Fig. 1: a) Boost converter b) Positive Buck-Boost converter

This approach has been utilised for both Boost (Fig. 1a) and PBB converters [1] (Fig. 1b). The hysteresis method is applied for the current control section and the hysteresis band height block is manipulated to improve the dynamic response of the Boost and PBB converters with respect to load disturbances. While the PBB converter can perform in step down and step up conversions, in this paper step up conversion is considered for making a comparison between the Boost and PBB converters.

A difference between the Boost converter and the PBB converter is the “Buck Switch” S_{Buck} and “Buck Diode” D_{Buck} as shown in Fig.1b. There is an extra freedom degree for the PBB converter because of this extra switch. The utilization of this freedom degree has been investigated in [1] by the storage of extra current in the inductor to disturbance rejection [5] for the PBB converter. Simulation results are

presented in Fig.2, to show the advantages of the inductor over-charging. In Fig.2a the inductor is 20% overcharged and as a result, the output voltage is undisturbed when the load is changed.

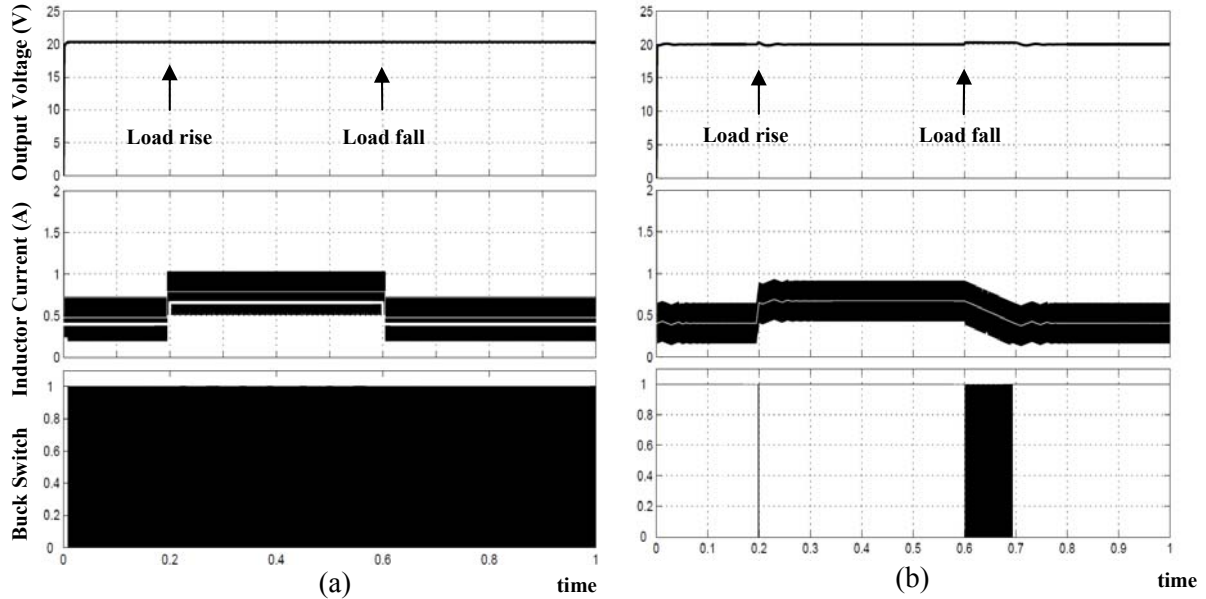

Fig 2: Performance of PBB converter with inductor over-charging (a) without SLC (b) with SLC
Load has changed from 100Ω to 60 Ω (0.2sec) and reverse (0.6sec)

The main disadvantage of that approach is the extra losses due to overcharging the inductor. In [1], a Smart Load Controller (SLC) is suggested to solve the low efficiency problem for some applications when a load is pre-known or may be predicted. In this case, the inductor current is increased before turning on a new device (increasing load). Fig.2b shows a simulation result regarding the performance of the PBB converter with an SLC. However, there are limited applications in which load can be predicted or controlled.

This paper presents a new method to increase the inductor current during transient which means there is no extra current stored in the inductor in a steady state. The freedom degree of the PBB converter is utilized to decrease output transient and improve quality of output voltage, after disturbances occur. Therefore, unlike the case in [1] there is no extra loss in steady state operation of the PBB converter in comparison with the Boost converter, and the load change is not assumed to be predicted.

Transient reduction has been investigated in [2] when a disturbance is on the input voltage. In the absence of disturbance, the PBB converter works almost the same as a Boost converter. S_{Buck} is turned on when the output voltage fluctuates. The topology of PBB converter has been usually used as a Buck or a Boost converter [3, 4, and 6], therefore, one of the switches does not operate.

In this paper, a controller is designed to control the PBB converter to work as a Boost converter in steady state operation, but when a disturbance occurs, both switches in the PBB converter operate to attenuate output voltage fluctuations. Boost converter dynamic has been investigated and compared with PBB converter for the same disturbances and conditions.

Load Disturbances

Sudden drop of output load causes overshoot and the sudden rise of output load leads to undershoot. The overshoot and undershoot problems in the output voltage of a Boost or a PBB converter depends on a few parameters such as:

- the level of load change
- circuit elements (L,C)

The higher value of the inductor the more energy is stored in the inductor for a given load. When the load suddenly reduces, the energy stored in the inductor should be consumed by the load because the Boost converter cannot decrease the inductor energy by any other element. Therefore, the S_{Boost} will be open and the inductor current is directed to the capacitor and load.

$$L \frac{di_L(t)}{dt} = V_{in} - v_C(t) \quad (1)$$

The load current is determined by capacitor voltage.

$$i_R(t) = v_C(t) / R \quad (2)$$

The capacitor voltage is determined by the difference between inductor current and load current.

$$C \frac{dv_C(t)}{dt} = i_L(t) - i_R(t) \quad (3)$$

The smaller value of the capacitor means the higher voltage change.

- Control loop
When load is changed, the inductor current reference is modified by the control loop. Having a faster control loop, overshoot/undershoot, and especially the recovery time after a load disturbance are reduced.
- Immediate response of the control system
In addition to gradually modifying the current reference, the control system may have an immediate response to load disturbances.

In this paper, a dynamic hysteresis band height control for a Boost and a PBB converter is presented. In addition, the PBB converter has an extra freedom degree, which is utilised to remove overshoots caused by load changes.

Control System

The fast current control loop is developed by a hysteresis control scheme. In addition, the current reference loop is developed in a V850E/IG3 microcontroller by an algorithm to change the reference current according to output voltage error on a regular basis. The block diagrams of the circuit and control system of the converters are illustrated in Fig.3.

Since the control strategy has a logical approach, the control system is illustrated as a flowchart in Fig.4a and switching states are shown in Fig.4b. The control strategy is the same for the Boost and PBB converters when there is no disturbance, but it differs when the disturbance affects the output voltage.

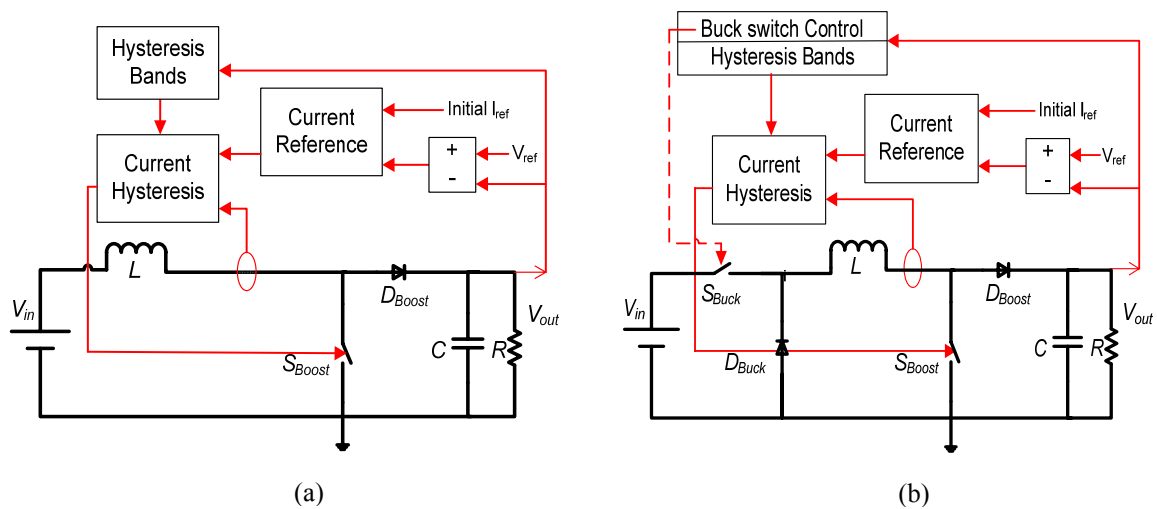

Fig 3: Block Diagram of the control system of Boost converter (a) and PBB converter (b) with dynamic hysteresis band control

The flowchart in the red dashed box shown in Fig.4a controls the Boost converter while the green solid-line box is bypassed and is not considered. The green solid-line box is used to control the PBB converter while the red dashed box is bypassed and is not considered for the PBB converter control. The other flowchart blocks in the Fig.4a are used to control both converters. In addition, the switching states of each converter are illustrated in Fig.4b which are related to decisions made in the flowchart.

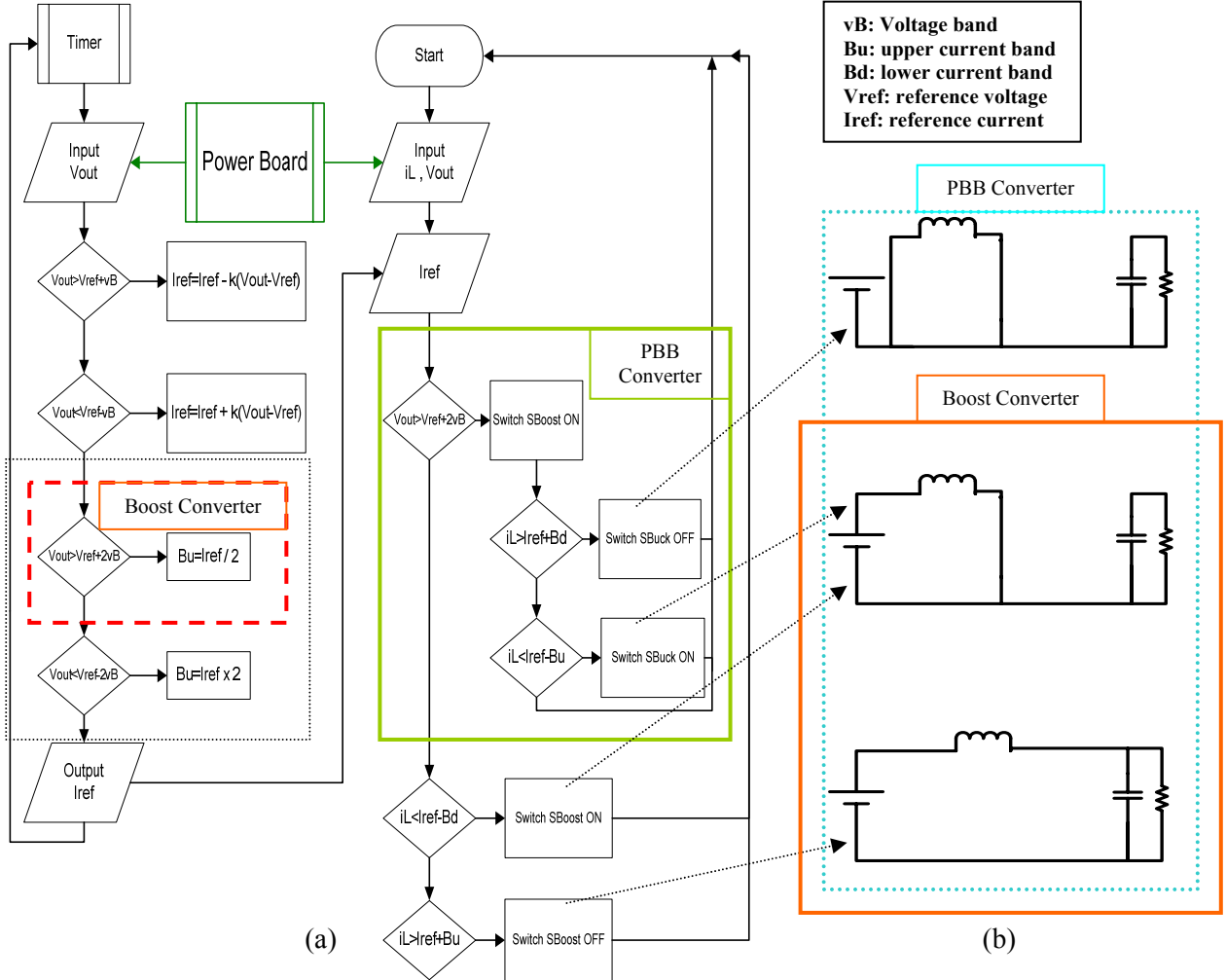

Fig. 4: a) the flowchart of control system. b) Switching states linked to control flowchart decisions

As described in Fig.4 and the above section, the difference between the Boost and PBB converter control methods is over-voltage handling strategies in these converters. The boost converter controller tries to reduce overvoltage by increasing the lower band height of the hysteresis current control (Fig.5). However, in the PBB converter, the ‘‘Buck switch’’ operates to avoid the overvoltage (Fig. 7, 11 & 12). In the case of an overshoot in the Boost converter, the lower band of hysteresis will be decreased to $I_{ref}/2$ so the average inductor current would be decreased to 75%. Eq.4 and Eq.5 show the changes of average inductor current for overshoot and undershoot, respectively.

In both the Boost and PBB converters, the strategy to reduce transient of the output voltage when an undershoot occurs is to increase the upper band height of the hysteresis current control. In the control flowchart and experimental results presented in this paper, the upper band height has been increased to 2 times of I_{ref} , thus, the average inductor current will be increased quickly by 150% and does not wait for a slow current reference loop to handle the undershoot.

$$B_u = n \cdot I_{ref} \Rightarrow \text{avg}\{I_L^{Osh}\} = \frac{n+1}{2} I_{ref} \quad (4) \quad \text{The average current when the upper band has increased}$$

$$B_d = I_{ref} / n \Rightarrow \text{avg}\{I_L^{Ush}\} = \frac{n+1}{2n} I_{ref} \quad (5) \quad \text{The average current when the lower band has decreased}$$

Where n is 2 in the control system presented in this paper.

The timer shown in Fig. 4 is developed in the microcontroller to modify the inductor current reference value according to the voltage error.

Simulation results

Several simulations have been carried out to validate the proposed control method. The control strategy and electrical parameters of the circuits are chosen to be close to the values applied in the experimental results.

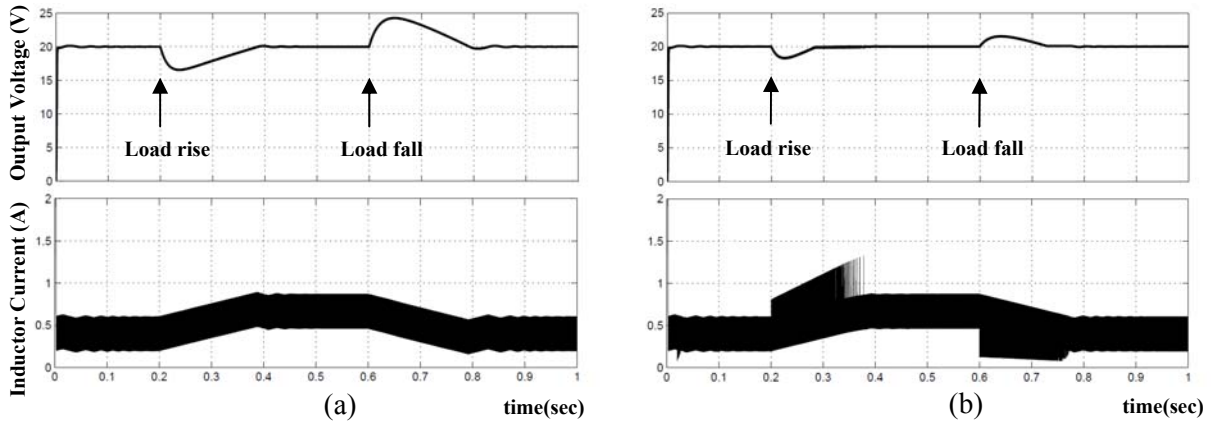

Fig 5: a) The dynamic of the Boost converter b) the dynamic of the Boost converter with a dynamic hysteresis band height. from 100Ω to 60Ω (0.2sec) and reverse (0.6sec)

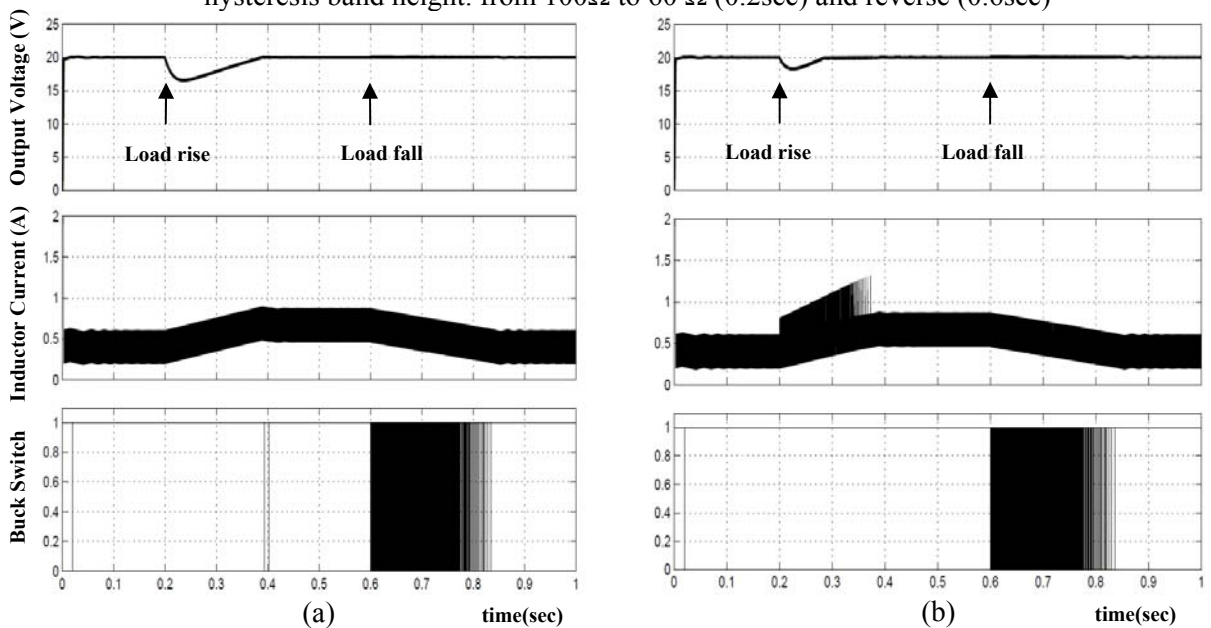

Fig 6: a) The dynamic of the case study PBB converter b) the dynamic of the case study PBB converter with a dynamic hysteresis band height. In addition, the performance of input switch is shown. from 100Ω to 60Ω (0.2sec) and reverse (0.6sec)

Fig. 6a illustrates the dynamic of a Boost converter after a step change in load. The load current is changed from 0.2A to 0.33A at 0.2s and turned back to 0.2A at 0.6s. The input voltage is 10V and the output voltage is controlled to be 20V, and the steady state value of the inductor current is twice as the load current. Voltage drop and voltage rise are dynamic consequences of this load disturbance. Fig.5b shows the enhancement achieved by the dynamic hysteresis band height control scheme on the Boost converter. The output voltage drop is reduced to half of the voltage drop shown in Fig.6a. Overshoot is reduced to one third of the overshoot shown in Fig.6a.

Fig.6a shows the results of load disturbance on a PBB converter without a dynamic hysteresis band height control system, which has been compared with a dynamic hysteresis band height control

system. In both graphs shown in Fig.6, the overshoot has been completely removed by the switching of the “Buck Switch”. The voltage drop has reduced to half of the voltage drop shown in Fig.6a. It is clear that a good controller may improve dynamic of the Boost converter, but the focus of this paper is to introduce the utilization of the dynamic hysteresis band height to improve the transient and dynamic of Boost and PBB converters for a given controller. For the same control system, different hysteresis band heights have been simulated to illustrate the relationship between the level of the dynamic hysteresis band height and overshoot and undershoot. It is important to address that the level of overshoots and undershoots depend on the load change. Thus, the simulations have been performed for two load changes: 100Ω to 60Ω and 100Ω to 30Ω and vice versa. The level of overshoots and undershoots and recovery time for each case are described and presented in Fig.7.

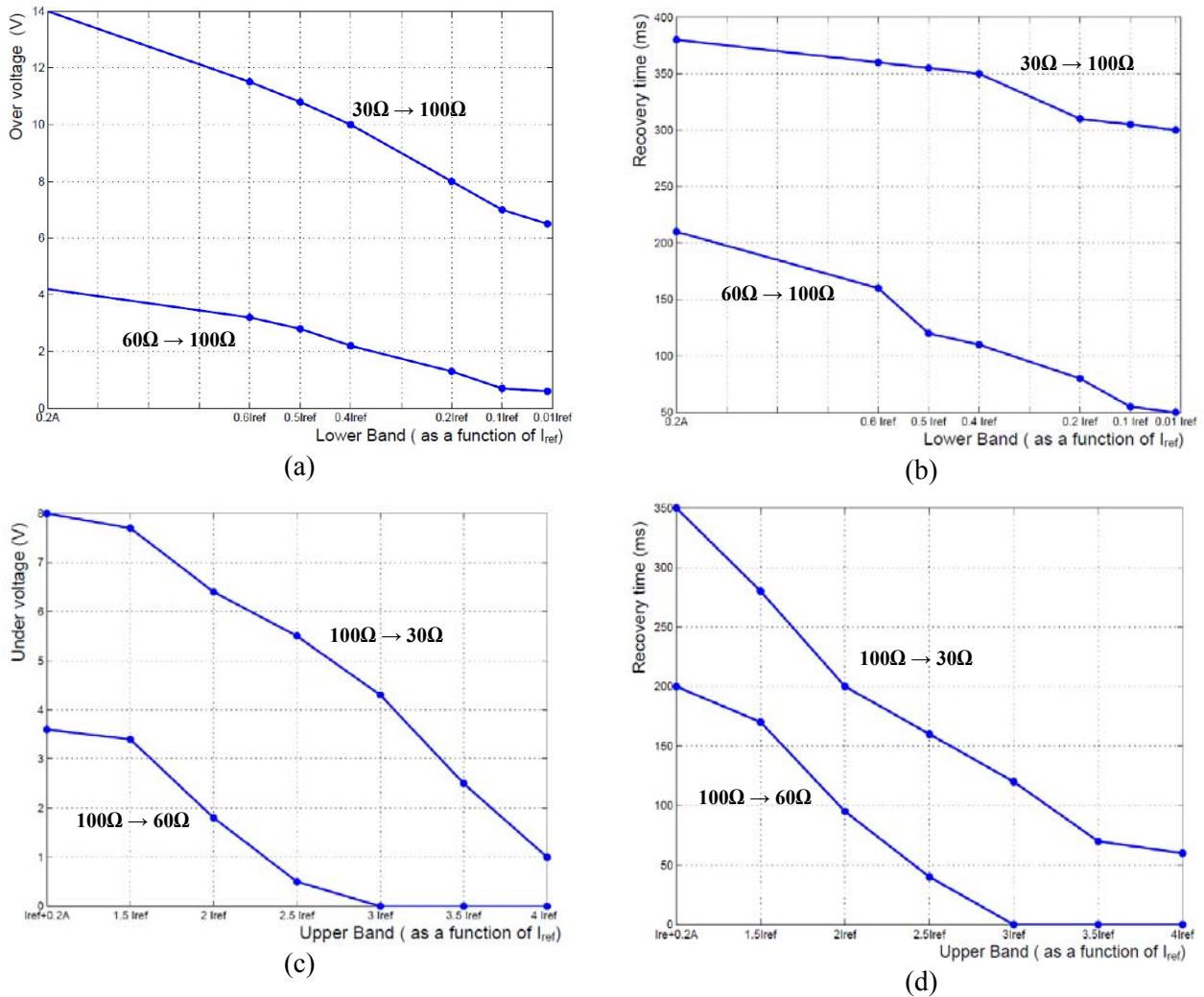

Fig 7: the over-voltage and under-voltage and recovery time in each case as a function of upper band and lower band of the hysteresis method for two load drops a) over-voltage b) over-voltage recovery time c) under-voltage d) under-voltage recovery

The general trend in Fig. 7 is to decrease overshoot/undershoot and the recovery time when the dynamic hysteresis strategy is applied with higher band changes. The origin of horizontal axis is the Upper ($I_{ref}+0.2A$) or Lower ($0.2A$) hysteresis band in steady state operation.

In practice, the results for high hysteresis bands may differ from the simulation because of the nonlinearity and saturation of the inductor. However, from these results, the limit of upper band increase is the maximum current of the inductor. The temporary increase of inductor current when there is an under-voltage does not increase the switching loss of the Boost switch, because by increasing the upper band the switching frequency decreases. When an over-voltage occurs, the lower band can decrease to zero and significantly reduce the over-voltage.

A laboratory prototype of Boost and PBB converters has been developed to validate the proposed control system and its performance in the presence of load change. The control system has been developed using NEC V850E/IG3 microcontroller. The experimental result of the proposed control strategy has been presented.

Experimental results

All of the disturbances are output load change from 100Ω to 60Ω and reverse. The output voltage is controlled to be 20V and the input voltage is 10V. The output capacitor is $470\mu\text{F}$ and the inductor is 1mH. In Figures 9-13, output voltage is marked with V_{out} and inductor current is marked with i_L . In Figures 11, 12, and 13, the “Buck switch” and its performance are highlighted.

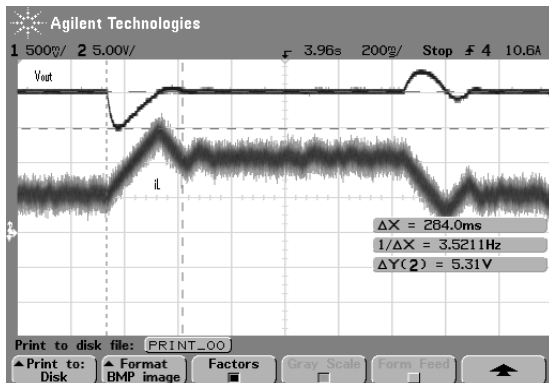

Fig 8: The overshoot and undershoot of a boost converter after load change

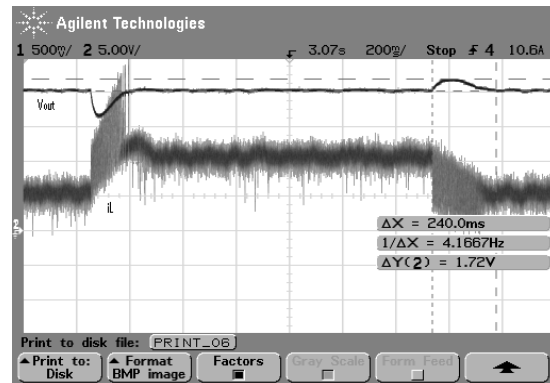

Fig 9: Reduction of output voltage transient by changing the hysteresis bands After occurrence of disturbance in Boost converter load

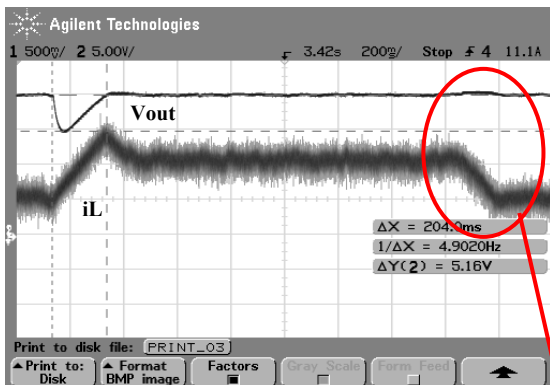

Fig 10: The overshoot and undershoot of a PBB converter after load change.

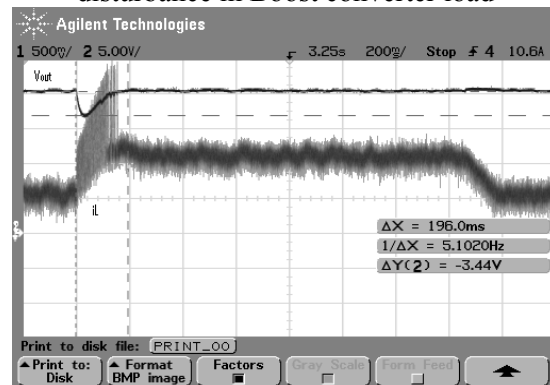

Fig 11: Reduction of output voltage transient by changing the hysteresis bands After occurrence of disturbance in PBB converter load

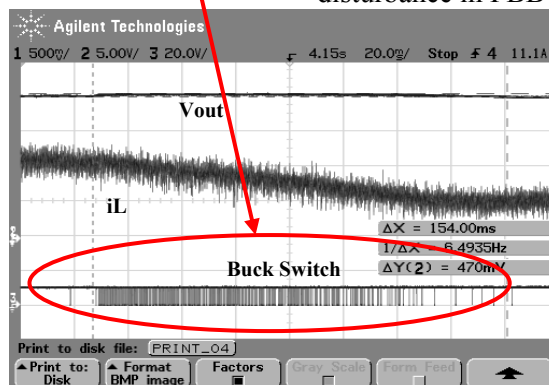

Fig 12: Reduction of overshoot by utilization of “Buck Switch” in PBB converter

Fig 9 shows the dynamic of a Boost converter when the hysteresis band height is constant. Fig.10 shows the performance of a Boost converter with the proposed control strategy. The upper band has been increased to $(2.I_{ref})$ in case of undershoot and decreased to $(I_{ref}/2)$ in case of overshoot. In Fig.9, the load has risen from 0.2A to 0.33A at 0.35s after the time origin. Load has dropped back to 0.2A at the time 1.4s. The voltage drop after load change is 5V and overshoot when the load is decreased again is 3V. Fig. 10 illustrates the performance of the presented scheme to quicken the recovery after load disturbance. The load change is the same as in Fig. 9. The voltage drop is 3V and overshoot is reduced to 1.5V. In addition, the recovery time has reduced by application of dynamic hysteresis band (200ms to 100ms). Fig. 11 illustrates the performance of PBB converter in the presence of output voltage fluctuation caused by load change. Hysteresis bands are constant in Fig. 11. The PBB converter has avoided overshoot by the switching of S_{Buck} connected to input voltage. The same operating condition (load drop and rise) has been considered for test and measurement, and the experimental result shows that the voltage drop in the Boost converter is 5V, as shown in Fig. 11. Fig. 12 is illustrates the performance of a PBB converter with dynamic hysteresis band height. The voltage drop has reduced to 3V while the load rise is same as Fig. 11. Fig. 13 shows the switching of S_{Buck} to avoid overvoltage when the output load has been decreased.

Conclusion

A control strategy with dynamic hysteresis band height has been presented in this paper for a Boost and PBB converter to reduce transient time and improve the dynamic of output voltage. An extra switch in a PBB converter has been utilised to avoid overshoot. Simulations have been carried out for different cases and the results have been compared with experimental results to validate the proposed method.

Reference

- [1] Boora, A.A.; Zare, F.; Ledwich, G.; Ghosh, A.; "A general approach to control a Positive Buck-Boost converter to achieve robustness against input voltage fluctuations and load changes" Power Electronics Specialists Conference, 2008. PESC 2008. IEEE 15-19 June 2008 Page(s):2011 - 2017
- [2] Chakraborty, Arindam; Khaligh, Alireza; Emadi, Ali "Combination of Buck and Boost Modes to Minimize Transients in the Output of a Positive Buck-Boost Converter"; IEEE Industrial Electronics, IECON 2006 - 32nd Annual Conferene on Nov. 2006 Page(s):2372 – 2377
- [3] Sahu, B.; Rincon-Mora, G.A.; "A low voltage, dynamic, noninverting, synchronous buck-boost converter for portable applications" Power Electronics, IEEE Transactions on Volume 19, Issue 2, March 2004 Page(s):443 - 452
- [4] Weissbach, R.S.; Torres, K.M.; "A noninverting buck-boost converter with reduced components using a microcontroller" SoutheastCon 2001. Proceedings IEEE 30 March-1 April 2001 Page(s):79 - 84 Digital Object Identifier 0.1109/SECON.2001.923091
- [5] Bosheng Sun; Zhiqiang Gao; "A DSP-based active disturbance rejection control design for a 1-kW H-bridge DC-DC power converter" Industrial Electronics, IEEE Transactions on Volume 52, Issue 5, Oct. 2005 Page(s):1271 – 1277
- [6] Lee, Y.-J.; Khaligh, A.; Emadi, A. "A Compensation Technique for Smooth Transitions in a Noninverting Buck–Boost Converter" IEEE Transactions on Power Electronics, Volume 24, Issue 4, April 2009 Page(s):1002 - 1015 Digital Object Identifier 10.1109/TPEL.2008.2010044
- [7] Qiang Zhou; Yong Huang; Fan Zeng; Quan-Shi Chen; "Dynamic Analysis of DC-DC Boost Converter Based on Its Nonlinear Characteristics"IEEE Industrial Electronics, IECON 2006 - 32nd Annual Conference on 6-10 Nov. 2006 Page(s):1769 - 1774 Digital Object Identifier 10.1109/IECON.2006.347823
- [8] "Impact of boost converter parameters on open-loop dynamic performance for DCM" Reatti, A.; Pellegrini, L.; Kazimierczuk, M.K.; IEEE International symposium on Circuits and Systems, 2002. ISCAS 2002. Volume 5, 26-29 May 2002 Page(s):V-513 - V-516 vol.5 Digital Object Identifier0.1109/ISCAS.2002.1010753
- [9] Sreekumar, C.; Agarwal, V. "A Hybrid Control Algorithm for Voltage Regulation in DC–DC Boost Converter"; IEEE Transactions on Industrial Electronics, Volume 55, Issue 6, June 2008 Page(s):2530 - 2538 Digital Object Identifier 10.1109/TIE.2008.918640
- [10] . Bryant, B.; Kazimierczuk, M.K. "Voltage loop of boost PWM DC-DC converters with peak current-mode control" : Regular Papers, IEEE Transactions on Circuits and Systems I Volume 53, Issue 1, Jan. 2006 Page(s):99 - 105 Digital Object Identifier 10.1109/TCSI.2005.854611