

# The Chaos Machine

## Analogue Computing Rediscovered (2)

By Maarten H. P. Ambaum and R. Giles Harrison (Department of Meteorology, University of Reading, UK),  
Jan Buiting and Thijs Beckers (Elektor Labs)

The analogue computer we set out to describe in the previous instalment was constructed from separate computation modules for multiplication, integration, summation and scaling, combined to represent the Lorenz 1963 equation system (ref. part 1). The circuits for the modules are largely based on suggestions in Peyton and Walsh, *Analog Electronics with Op Amps: A Source Book of Practical Circuits*, where more details on their functionality can be found. We found the use of breadboards very suitable for this project but have also made a soldered version that travels better.

### Modular approach to Chaos

**Figure 1** provides an overview of how the computational modules are combined, in terms of the signal paths and **Figures 2a through 2g** provide individual circuit schematics for each of the computational modules required. A summary of their function is given below, but first the

**Block diagram (Figure 1).** This figure shows the combination of computation modules required for the complete analogue computer. Triangles represent function modules, each with a set of inputs and a single output.

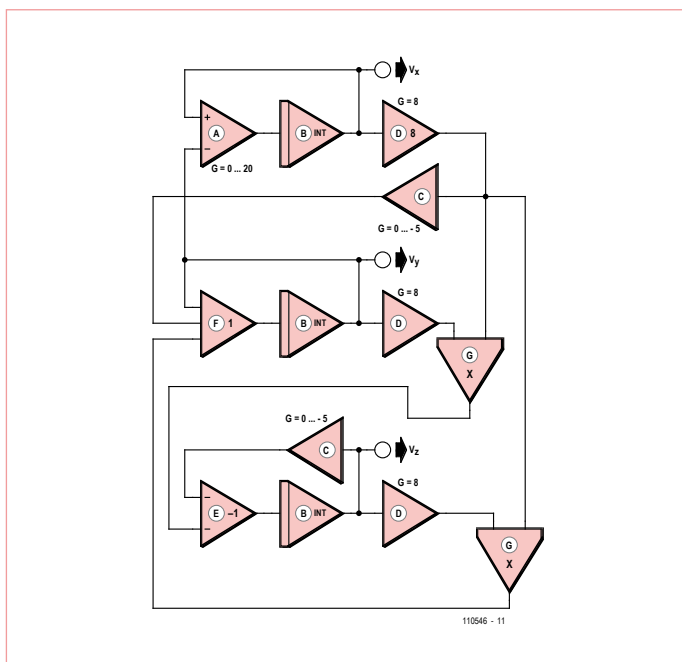

Figure 1. Block diagram of the Chaos Machine. Each function shown corresponds to one of seven basic circuits from Figures 2a through 2g, solving the Lorenz equations.

Symbols (+) and (–) are used to denote non-inverting and inverting inputs, and (×) multiplication. A thin rectangle on the input side of the triangle denotes an integrator. The gain-8 scaling amplifiers (ident: ‘D’) are included to ensure that the voltages in each wire do not exceed the stated maximum amplitude of ±10 V in any of the op amp input stages and the multiplier chip.

Output voltages are available at the three nodes marked  $V_x$ ,  $V_y$ ,  $V_z$ , for use with an oscilloscope having an ‘xy’-display mode and ‘z’ axis (intensity) modulation.

This model has a control (in module ‘A’) to vary the Prandtl number (parameter  $\sigma$  in the Lorenz equations) between 0 and 20, to display the different regimes of the Lorenz equations.

**A: Differential Amplifier (Figure 2a).** Input voltages  $V_1$  and  $V_2$  are buffered by dual amp stage A1, subtracted in op amp stage A2.A, and then amplified by an inverting amplifier stage A2.B with gain  $G$  (up to  $\times -20$ ). Function:  $V_{out} = G(V_1 - V_2)$ .

**B: Inverting Integrator (Figure 2b).** Input voltage  $V_1$ , referred to the signal ground, is buffered by op amp stage A2.A, and then integrated by stage A2.B. A dual op amp package provides both amplifiers. Function:  $V_{out} = \int V_1 dt / (3.3 \times 10^{-4} s)$

**C: Inverting Scaling Amplifier (Figure 2c).** Input voltage  $V_1$ , referred to the signal ground, is buffered, and applied to an inverting amplifier stage with variable gain  $G$  (up to  $\times -5$ ) set by the 100 k $\Omega$  potentiometer. Function:  $V_{out} = -GV_1$ . Top C:  $G = -3.5$ ; bottom C:  $G = -2.7$ .

**D: Non-inverting Scaling Amplifier (Figure 2d).** Input voltage  $V_1$ , referred to the signal ground, is buffered, and amplified by a non-inverting stage with a fixed gain of 8. Function:  $V_{out} = 8V_1$ .

**E: Inverting Summer Amplifier (Figure 2e).** Input voltages  $V_1$  and  $V_2$  are buffered, and added in the third, inverting, stage. A dual op amp package provides both input amplifiers, and a further package, the summation stage. Function:  $V_{out} = -(V_1 + V_2)$ .

**F: Non-inverting Summer Amplifier (Figure 2f).** Each of the three input voltages  $V_1$ ,  $V_2$ , and  $V_3$  are buffered, and then added in a summation stage. Two dual op amp packages can be used. Function:  $V_{out} = V_1 + V_2 + V_3$ .

**G: Multiplier (Figure 2g).** A function chip (type AD633) is used to determine the product of two input voltages, with a further non-inverting stage contributing a gain of  $\times 10$  to establish a scaling voltage  $V_0$  of 1 V. Function:  $V_{out} = V_1 \times V_2 / V_0$ .

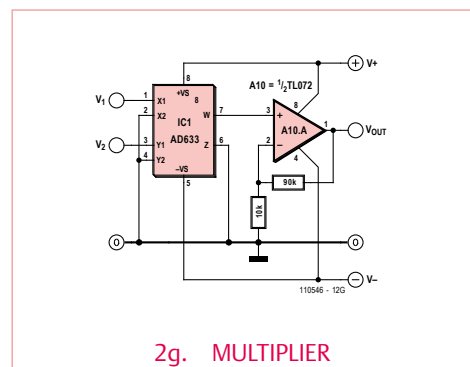
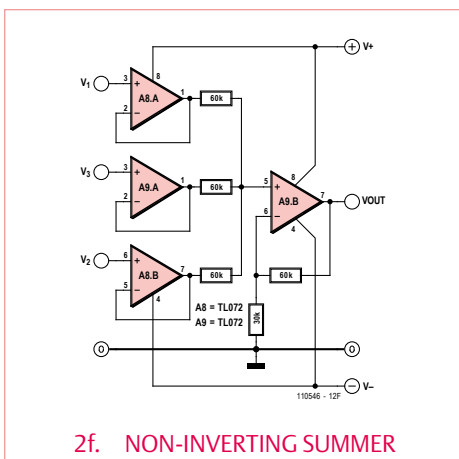
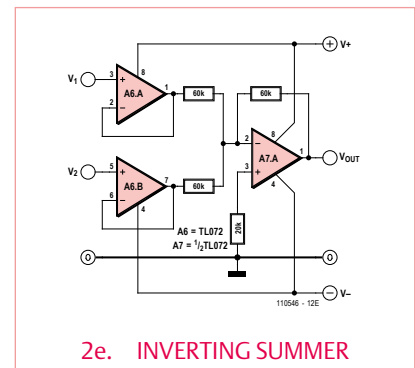
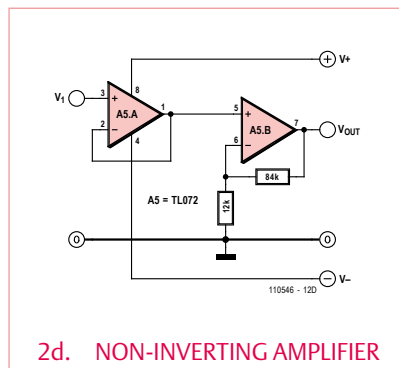
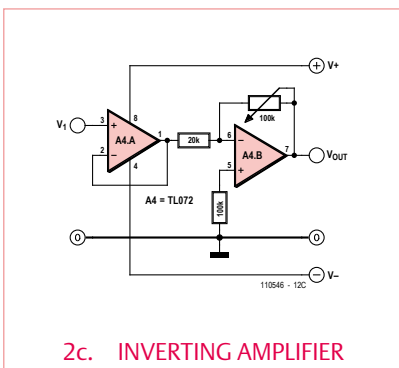
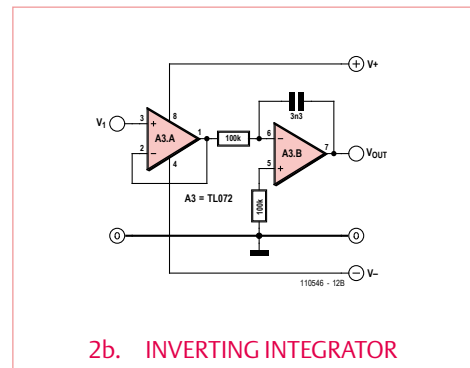
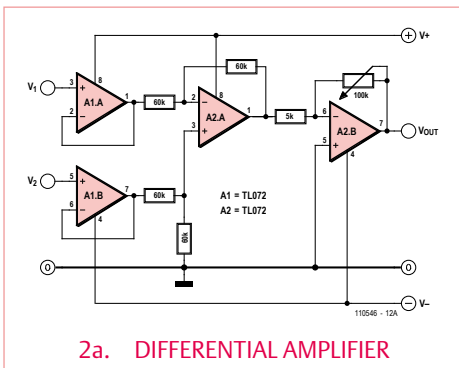

Figure 2. Overview of all required mathematical functions required for the Chaos Machine, realised using op amps for the most part.

## Chaos in theory

The basic conclusion of Lorenz's work is that even if you know the initial conditions quite precisely the error in specifying the initial condition rapidly grows, so that after even a short time we cannot predict the *details* of the motion — the sensitive dependence on initial conditions is one of the defining properties of chaos.

## Chaos for real

By Jan Buiting, Editor.

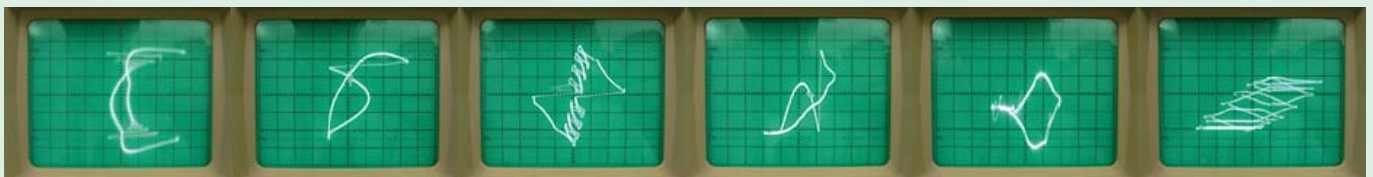

Retronics instalments normally meet with silent understanding and approval from Elektor's technically inclined people, and mild surprise or the odd chuckle from all other staff seeing and hearing vintage equipment hauled into and out of the damp cellars of medieval Elektor House. However when the word was out that "*Chaos has descended upon Jan's pages in the September 2011 edition*" many staff were disenchanted to see a neatly formatted Retronics instalment with solid content, and no chaos or other disordered mess to revel at.

Keen to experience chaos for real, a few enthusiasts murmured and then suggested to actually build the Chaos Generator and so we did, where 'we'  $\approx$  [Thijs Beckers  $\pm$  Jan Buiting] of *Chaosfree Desks*, a small, quiet faction within the Elektor editorial and lab bunch.

The math functions that hopefully enable the generator to behave chaotically were linked to circuits, components and eventually, modules for interconnecting with wires (signals as well as power supply). The thing worked spot on, producing bizarre images on our Hameg oscilloscope in x-y mode (sadly, all models with z modulation were on the blink). Turning the two pots and occasionally introducing stray capacitance with our fingers under some boards, we were able to produce extremely complex shapes ranging from sea horses to Möbius' bands, DNA strings, styled epsilons and even business models not unfit for graduating Hons. at the *London School of Economics* (LSE) we told our MD, accounts and marketing staff. Dilbert and Professor Bill Phillips would have loved it. For example, advancing the pot on module 'A' (LSE: "upping XYZ Corp.'s sales resources") beyond a certain critical level caused the entire riotous scope image (LSE: "this highly creative organisation") to change shape (LSE: "come to terms with its budgets"), then DC-shift off the scope screen (LSE: "go in pursuit of other challenges") and finally bounce back on to the screen looking like a violent vortex not unlike that in an aircraft toilet (LSE: "sudden depreciation of assets"). As fickle as modern financial markets!

Some of the better chaotic images are shown in this inset, as well as filmed for a video clip you can view on Elektor's very own YouTube Channel (details to be announced online). All of the the images shown here are likely due to opamp saturation at some point in the system.

The sound signals taken from the outputs were as impressive and uncanny as Maarten and Giles mentioned in part 1 of this article. You have to hear it believe it and everyone's invited to check it out at the Elektor Live! event this November.

To some the generator is a gizmo you just can't resist tweaking and adjusting by means of the two controls for yet more wacky shapes on the 'scope screen. To others, it is a serious implementation of complex mathematical functions a powerful DSP or PIC micro would be challenged to produce equal results, i.e. visually and at speed. Admittedly the practical use of the machine is limited at best, with some consolation that the weather is the largest recognised chaotic system we know — with some workplaces at Elektor House happily contending for second place.

At this point, we challenge our readers to investigate if their powerful 32- and 64-bit electronics simulation programs and PCs are up to the disarmingly simple Chaos Generator circuitry shown here. Failing that, or tired of error reports popping up (*Division by Zero!*), send us the best application of the Chaos Generator you can think of! Or a Chaos applet for the iPhone or Android allowing top ranking business people to use it on the train — there's money to be made.

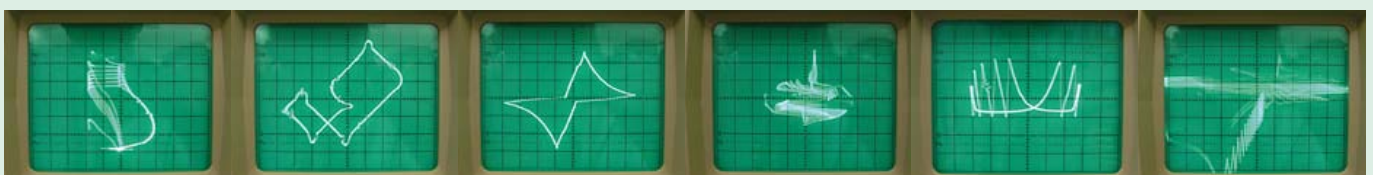

# live! chaos

Experience the Chaos Generator at Elektor Live! 2011  
Elektor Audio & Retro Division  
Eindhoven, The Netherlands, November 26

## Suggestions for construction

At Reading University, the components for the prototype were assembled on solderless breadboard, using a separate breadboard for each functional module. All the circuit stages were powered from a common  $\pm 15$  V power supply, with a conventional ground voltage of 0 V throughout. The operational amplifiers used were type OP97. This op amp is available in single (OP97) and dual versions (OP297), which can be combined to reduce the number of integrated circuit packages required, whilst preserving the independence of the modules. Pin numbers refer to the standard dual in-line integrated circuit packages for the OP97 and OP297. The multiplication stages use a mathematical function chip, the AD633, which uses the same bipolar power supplies.

The replica of the Chaos Machine built at Elektor Labs uses TL072 op amps throughout for the simple reason that they happened to be available. Also, some of the theoretical resistance values like 60 k $\Omega$  were replaced by their nearest real-life equivalents lurking in component drawers. To add some aesthetics to the project, the modules were secured to a central post made from stacked PCB pillars, and turned to resemble the steps of a virtually round staircase, see **Figure 3**. 'Elektor Universal Prototyping Board size-1' (UPB-1 a.k.a. Elex-1) was used to construct all modules and give them a uniform look. The boards were labelled and some duplicated to enable other mathematical functions and configurations to be set up.

**Acknowledgements:** This project was stimulated through interdisciplinary workshops of artists and scientists led by artist Charlie Hooker of the University of Brighton Fine Art Department, UK. The analogue computer was built in the Meteorology Department laboratories by Stephen R. Tames, at Reading University, UK.

(110546)

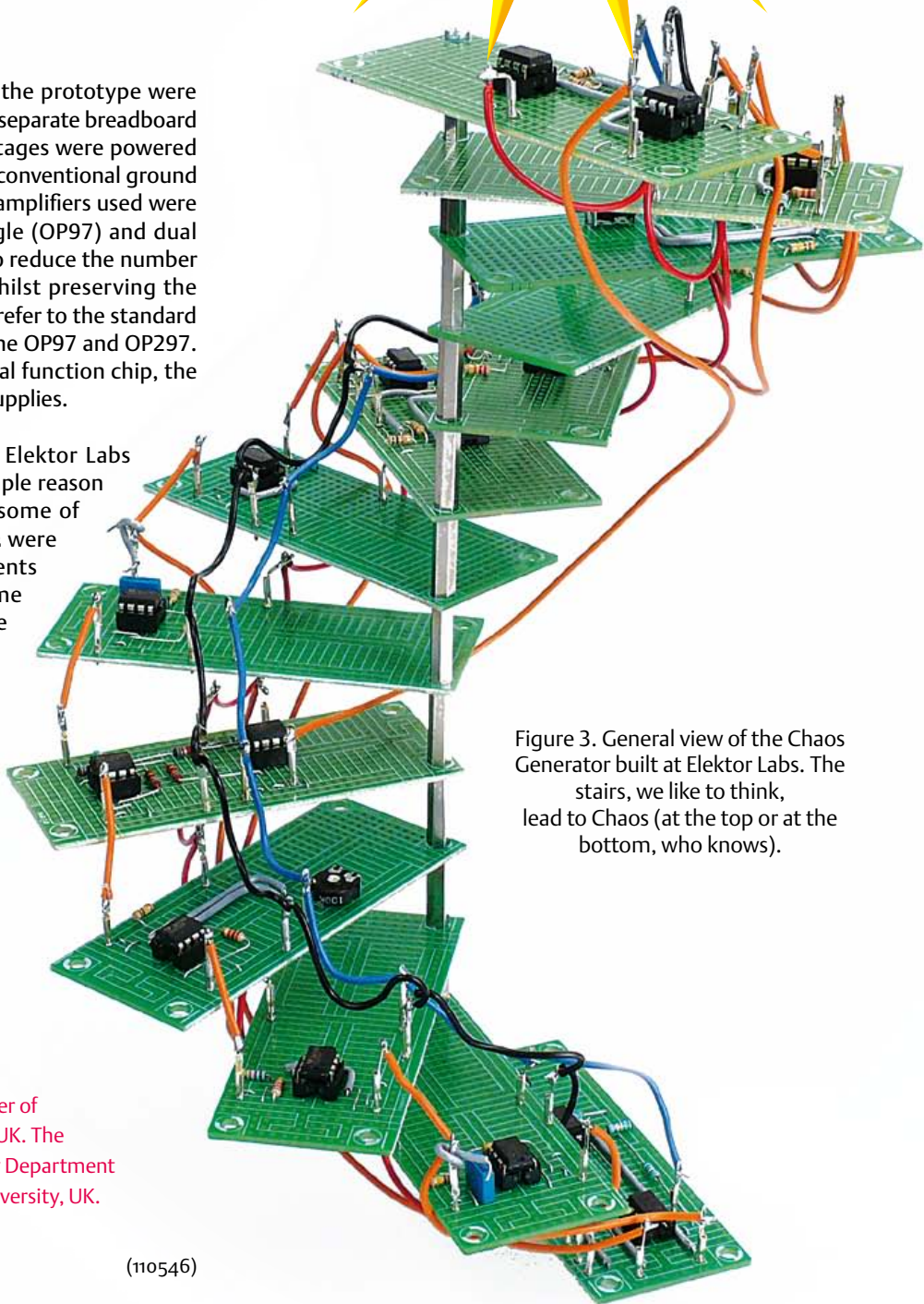

Figure 3. General view of the Chaos Generator built at Elektor Labs. The stairs, we like to think, lead to Chaos (at the top or at the bottom, who knows).