

# SECOND ORDER LOW-PASS AND HIGH-PASS FILTER DESIGNS USING METHOD OF SYNTHETIC IMMITTANCE ELEMENTS

Pavel BRANDSTETTER<sup>1</sup>, Lukas KLEIN<sup>1</sup>

<sup>1</sup>Department of Electronics, Faculty of Electrical Engineering and Computer Science, VSB–Technical University of Ostrava, 17. listopadu 15/2172, 708 33 Ostrava, Czech Republic

pavel.brandstetter@vsb.cz, lukas.klein@vsb.cz

**Abstract.** The paper briefly describes the basics of frequency filter design method using synthetic immittance elements with current conveyors. An introduction of the paper explains the advantages and also disadvantages of using this method. Other chapters briefly introduce a design process of simple second order low-pass and high-pass filter. A theory of current conveyors is discussed too, because they are the basic building blocs of proposed synthetic element and also active frequency filters. Finally, the particular solutions of low-pass and high-pass filters are given and verified by OrCAD PSpice simulations.

## Keywords

Low-pass filter, high-pass filter, frequency filter, synthetic immittance element, current conveyor.

## 1. Introduction

Current conveyor can be considered well-known active element. However, this electronic building block is still waiting for its user expansion since 1968 [1]. Currently, a lot of new applications using current conveyors were proposed and new applications will be designed because current conveyor can be used in various electronic circuits [2].

Current conveyors are applied not only in the basic electronic circuits, but also in more comprehensive circuit structures. Our previous papers prove the fact, that current conveyor can be considered universal active element [2]. One of the many areas of electronics, where current conveyors can be successfully used is a field of active frequency filters. These electronic applications can be used especially in mobile devices mainly because of positive properties of current conveyors. These active elements allow the realization of

circuits working at higher frequencies (practically till 80 MHz) and also need relatively low power supply voltage 5 V. These positive properties predestine these electronic parts for wider use in various types of modern electronic applications. The main disadvantages of current conveyors are their low commercial availability and still relatively high price of integrated circuits, which currents conveyors are part of.

## 2. Current Conveyors

Current conveyors can be described as modern active elements. They have three types of terminals. Terminals labeled X represent current inputs and simultaneously voltage outputs with positive or negative transfer of voltage from terminal Y, terminals Y are voltage inputs. Terminals Z represent current outputs with positive or negative transfer of current from terminal X [1]. Schematic symbol of four-port general current conveyor, which is used for synthetic immittance element design, is shown in Fig. 1.

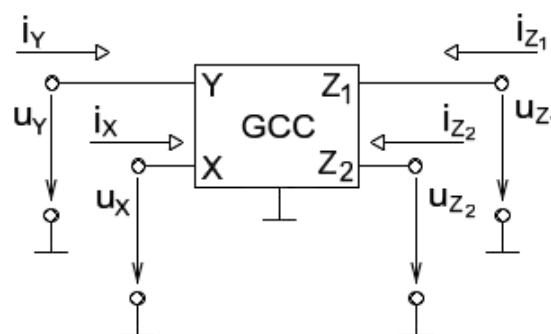

Fig. 1: Schematic symbol of four-port general current conveyor.

Four-port general current conveyor has four coefficients, namely:  $a$ ,  $b$ ,  $c_{11}$ ,  $c_{22}$ . The coefficient  $a$  represents the voltage transfer from terminal Y to terminal

X, b represents the current transfer from terminal X to terminal Y and  $c_{11}$ ,  $c_{22}$  represent the current transfers from terminal X to terminals  $Z_1$  and  $Z_2$ .

Matrix form of characteristic equations describing the behavior of four-port general current conveyor [3] can be expressed as follows:

$$\begin{bmatrix} u_x \\ i_y \\ i_{z_1} \\ i_{z_2} \end{bmatrix} = \begin{bmatrix} 0 & a & 0 & 0 \\ b & 0 & 0 & 0 \\ c_{11} & 0 & 0 & 0 \\ c_{22} & 0 & 0 & 0 \end{bmatrix} \begin{bmatrix} i_x \\ u_Y \\ u_{z_1} \\ u_{z_2} \end{bmatrix}. \quad (1)$$

Particular coefficient values define the current conveyor variations [2]. Coefficient  $a$  defines inverting/non-inverting conveyor. Coefficient  $a = 1$  determines the non-inverting current conveyor. On the other side, if coefficient  $a = -1$ , then it is an inverting current conveyor.

Coefficient  $b$  defines current conveyor generation. The first generation current conveyors are defined by coefficient  $b = 1$ . The second generation current conveyors have coefficient value  $b = 0$ . The third generation current conveyors are defined by coefficient  $b = -1$ .

Coefficient  $c$  determines positive/negative current conveyor. Coefficient  $c = 1$  determines positive current conveyor. If the value of the coefficient is  $c = -1$ , it is a negative current conveyor.

### 3. Synthetic Immittance Elements Design

Current conveyors are also used for realization of synthetic immittance elements of higher orders. Synthetic dipoles with immittances of higher order [4] are divided into four groups - DP, DS, EP, ES. They are comprised of serial or parallel circuitries of elementary dipoles of D type or E type. Synthetic elements DS and DP are serial respectively parallel circuitry of D type elementary dipoles and synthetic elements ES and EP are serial respectively parallel circuitry of E type elementary dipoles [5].

As stated above, synthetic dipoles with immittances of higher order [5] are consisting of serial or parallel elementary dipoles connections:

- dipole DS  $N_{D,min}$ ,  $N_{D,max}$  consists of a serial connection of synthetic elementary dipoles of type  $D_n$  for  $n = N_{D,min}, N_{D,min} + 1, \dots, N_{D,max} - 1, N_{D,max}$ ,
- dipole DP  $N_{D,min}$ ,  $N_{D,max}$  consists of a parallel connection of synthetic elementary dipoles of type  $D_n$  for  $n = N_{D,min}, N_{D,min} + 1, \dots, N_{D,max} - 1, N_{D,max}$ ,

- dipole ES  $N_{E,min}$ ,  $N_{E,max}$  consists of a serial connection of synthetic elementary dipoles of type  $E_n$  for  $n = N_{E,min}, N_{E,min} + 1, \dots, N_{E,max} - 1, N_{E,max}$ ,
- dipole EP  $N_{E,min}$ ,  $N_{E,max}$  consists of a parallel connection of synthetic elementary dipoles of type  $E_n$  for  $n = N_{E,min}, N_{E,min} + 1, \dots, N_{E,max} - 1, N_{E,max}$ .

Immittance function of DS and DP synthetic elements is given by equations Eq. 2 and Eq. 3, [5]. Immittance function symbolic forms of ES and EP synthetic elements are given by equations Eq. 4 and Eq. 5, [5]. Synthetic immittance element design process starts by the general circuit network proposition. This circuitry is consisting of nine passive elements (admittances) and one general four-port current conveyor (GCC). This general circuit network is shown in Fig. 2.

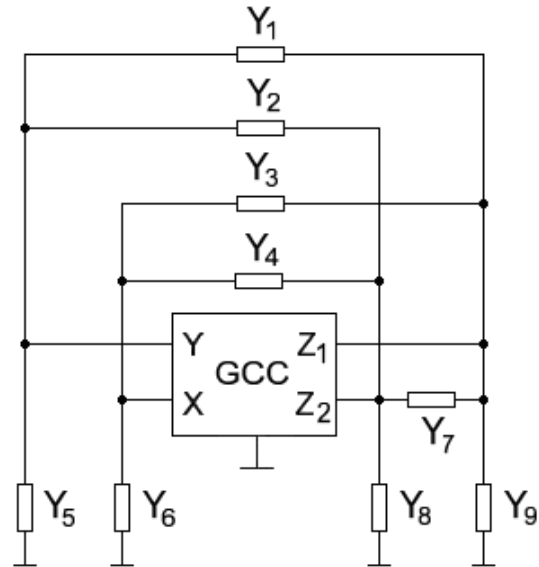

Fig. 2: General circuit network suitable for synthetic element design.

Necessary number of admittances to realize the synthetic element is three. Therefore all remaining admittances are removed [6]. Selection of appropriate admittances is random. Then particular values of general four-port current conveyor coefficients  $a$ ,  $b$ ,  $c_{11}$ ,  $c_{22}$  are added. These coefficients can take discrete values  $a = \{-1; 1\}$ ,  $b = \{-1; 0; 1\}$ ,  $c = \{-1; 1\}$  as was mentioned above [6].

#### 3.1. Proposed Synthetic Immittance Element Solution

There were found several circuit structures suitable for synthetic immittance elements realization. Particular

$$Z_{DSN_{D,min},N_{D,max}}(p) = \sum_{n=N_{D,min}}^{n=N_{D,max}} Y_{D_n}^{-1}(p) = (p^{N_{D,min}} D_{N_{D,min}})^{-1} + (p^{N_{D,max}} D_{N_{D,max}})^{-1}. \quad (2)$$

$$Y_{DPN_{D,min},N_{D,max}}(p) = \sum_{n=N_{D,min}}^{n=N_{D,max}} Y_{D_n}(p) = p^{N_{D,min}} D_{N_{D,min}} + p^{N_{D,max}} D_{N_{D,max}}. \quad (3)$$

$$Z_{ESN_{E,min},N_{E,max}}(p) = \sum_{n=N_{E,min}}^{n=N_{E,max}} Z_{E_n}(p) = p^{N_{E,min}} E_{N_{E,min}} + p^{N_{E,max}} E_{N_{E,max}}. \quad (4)$$

$$Y_{EPN_{D,min},N_{D,max}}(p) = \sum_{n=N_{E,min}}^{n=N_{E,max}} Z_{E_n}^{-1}(p) = (p^{N_{E,min}} E_{N_{E,min}})^{-1} + (p^{N_{E,max}} E_{N_{E,max}})^{-1}. \quad (5)$$

$$Y_{IN} = \frac{Y_2 Y_7 - Y_2 Y_7 a + Y_2 Y_7 b - Y_2 Y_7 ab + Y_2 Y_7 c_{11} - Y_2 Y_7 ac_{11}}{Y_2 + Y_2 c_{11} + Y_7 + Y_7 c_{11} + Y_7 c_{22}} + \frac{Y_2 Y_7 c_{22} - Y_2 Y_7 ac_{22} - Y_2 Y_9 ab - Y_2 Y_9 ac_{22} - Y_7 Y_9 ab}{Y_2 + Y_2 c_{11} + Y_7 + Y_7 c_{11} + Y_7 c_{22}}. \quad (6)$$

solution of one of them is presented in the following text. Particular solution of circuit suitable for realization of synthetic immittance element is shown in Fig. 3.

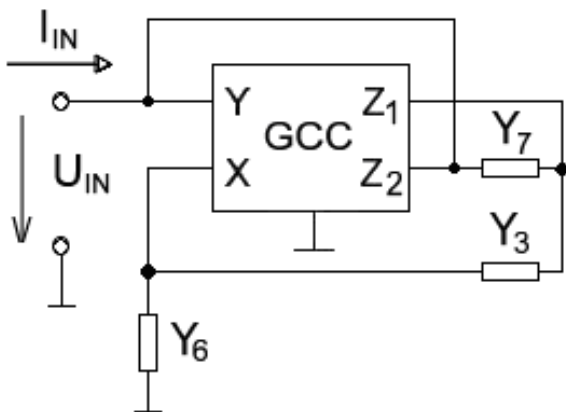

Fig. 3: General circuit structure suitable for implementation of synthetic immittance element.

This circuitry is consisting of three selected admittances and one GCC. General input admittance of the circuit solution has the form 6. This equation has suitable form for following implementation of DP or EP type synthetic element [5]. If suitable synthetic immittance elements of higher order should be designed, then an appropriate form of input admittance is searched [6]. The required input admittance of synthetic immittance elements of DS and ES type should have the form:

$$Y_{IN} = \frac{Y_V Y_W}{Y_U + Y_W}. \quad (7)$$

Increase of synthetic element order is done by repeatedly replacing admittance  $Y_V$  by a circuit with input admittance Eq. 7. For synthetic immittance elements of DP and EP type, it is required input admittance in the form:

$$Y_{IN} = \frac{Y_U Y_V}{Y_W} + Y_U. \quad (8)$$

Admittance  $Y_V$  is repeatedly replaced with a circuit with the input admittance Eq. 8, if we want to increase the order of synthetic immittance element.

Another step of synthetic immittance element design process is the substitution of current coefficients, which define a particular type of current conveyor, into the equation Eq. 6. There were chosen coefficients  $a = 1$ ,  $b = 0$ ,  $c_{11} = -1$ ,  $c_{22} = -1$ , which define a non-inverting negative four-port current conveyor CCII-, [2]. This modification affects and simplifies the input admittance of the circuit. The changed equation then has the form:

$$Y_{IN} = \frac{Y_6 Y_3}{Y_7} + 2Y_6. \quad (9)$$

The final step is a suitable choice of passive elements (resistors, capacitors) and their substitution on the places of general admittances [6]. The resulting circuitry of a second-order synthetic immittance element of DP type is shown in Fig. 4.

Characteristic input admittance is defined by the equation of the form:

$$Y_{IN} = p^2 R_7 C_3 C_6 + 2p C_6. \quad (10)$$

$$K_U(p) = \frac{1}{p^3 + 2R_1R_2C_1C_2C_3 + 2p^2 (R_1R_3C_2C_3 + 2R_1C_1C_2) + p(4R_1C_2 + R_1C_1) + 1}. \quad (11)$$

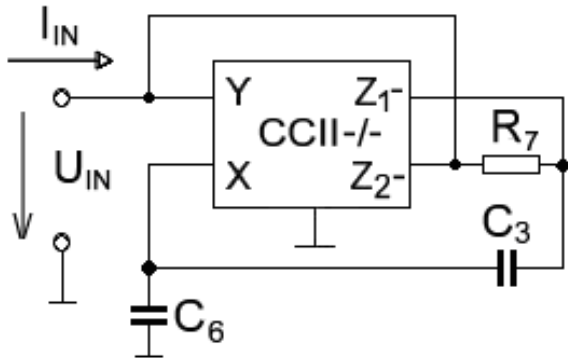

Fig. 4: Second order synthetic immittance element of DP type.

### 4. Frequency Filters with Synthetic Immittance Elements

Second order low-pass is shown in Fig. 5. This solution of frequency filter uses synthetic element shown in Fig. 4 in its circuit structure. Low-pass filter was created by substitution of synthetic element into the general structure of the voltage divider. There was added also first order passive low-pass into the structure of second order active low-pass because of shaping of amplitude frequency response at higher frequencies.

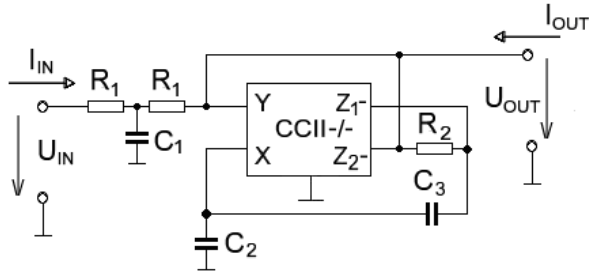

Fig. 5: Second order low-pass filter with synthetic immittance element.

Transfer function of resulting circuit structure of second order low-pass filter is described by equation 11. From the transfer function then can be derived the design formulas of passive elements of active filter. These formulas have forms:

$$R_1 = \frac{c_{21}}{4 \omega_0 C_2}, \quad (12)$$

$$R_2 = \frac{2c_{22}}{\omega_0 c_{21} C_3}. \quad (13)$$

There was chosen Butterworth approximation and cut-off frequency 1 MHz for the filter. Coefficients of second order Butterworth approximation take the values  $c_{21} = 1,4142$  and  $c_{22} = 1$ . There were calculated the following values of passive elements:  $C_1 = 270$  pF,  $C_2 = 100$  pF,  $C_3 = 100$  pF,  $R_1 = 560$   $\Omega$  and  $R_2 = 2,2$  k $\Omega$ .

Second order high-pass filter was also proposed. Circuitry of high-pass solution is shown in Fig. 6. In this case, there were again chosen Butterworth approximation and cut-off frequency 1 MHz. Design formulas are based on the transfer function of frequency filter. Transfer function has the form:

$$K_U(p) = \frac{p^2 R_1 R_2 C_1 C_2}{p^2 R_1 R_2 C_1 C_2 + 2p R_2 C_2 + 1}. \quad (14)$$

Design formulas of passive elements then have forms:

$$R_2 = \frac{c_{21}}{2 \omega_0 C_2}, \quad (15)$$

$$R_1 = \frac{2c_{22}}{\omega_0 c_{21} C_1}. \quad (16)$$

Second order high-pass has the resulting values of passive elements  $C_1 = 100$  pF,  $C_2 = 100$  pF,  $R_1 = 1,1$  k $\Omega$  and  $R_2 = 2,2$  k $\Omega$ .

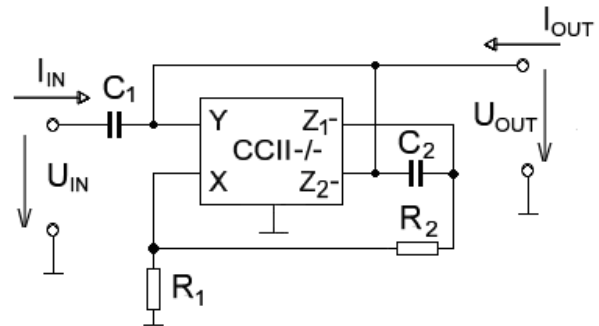

Fig. 6: Second order high-pass filter with synthetic immittance element.

The frequency responses of second order low-pass and high-pass express the dependence of filter gain or phase vs. changing frequency. The final amplitude and phase frequency responses were simulated using PSpice. There was used Monte Carlo simulation to proof the influence of passive elements tolerance in to the amplitude and phase frequency responses. The greatest influence on the shape of resulting responses has change of capacitors tolerances. Monte Carlo analysis shows the influence of continuous various values of capacitor tolerances. The resulting amplitude and

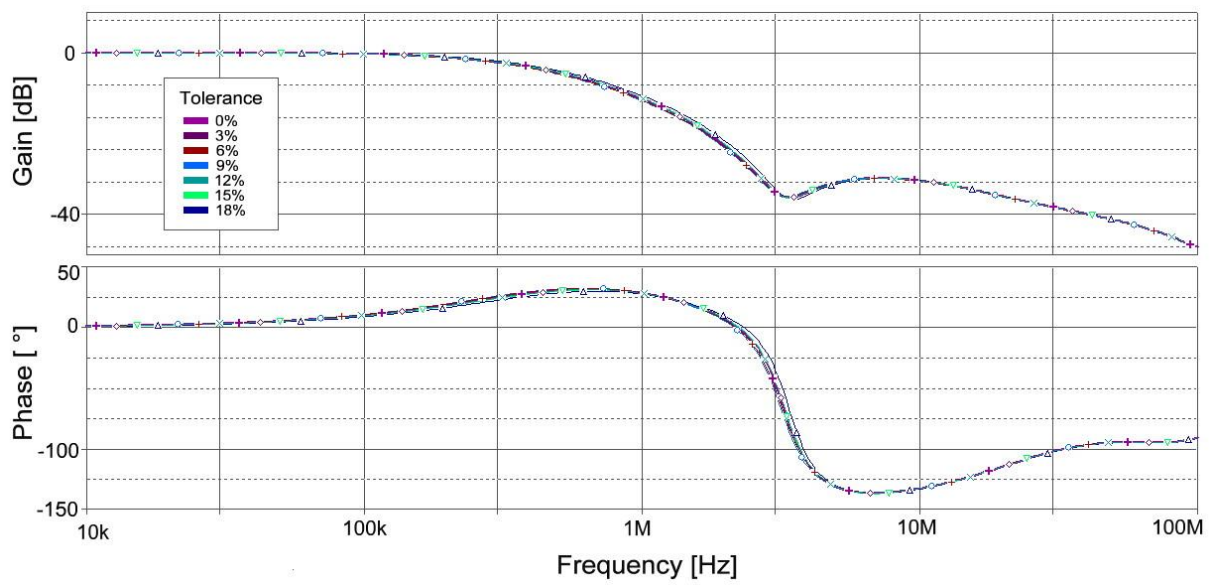

Fig. 7: Amplitude and phase frequency response of second order low-pass filter.

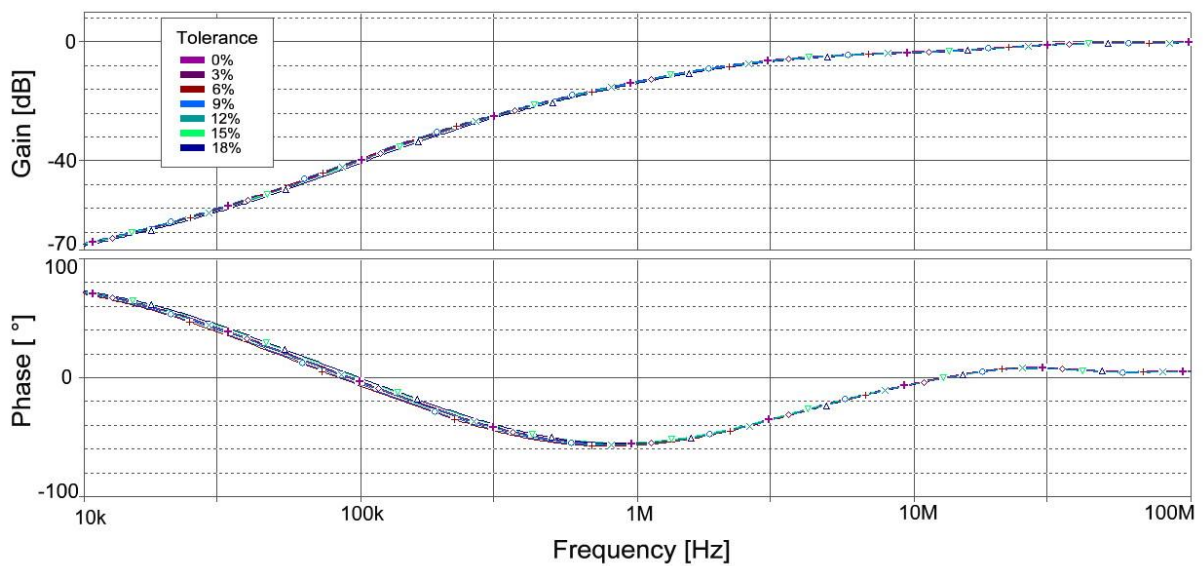

Fig. 8: Amplitude and phase frequency response of second order high-pass filter.

phase frequency responses of low-pass are shown in Fig. 7. Amplitude and phase frequency responses of high-pass are shown in Fig. 8.

## 5. Conclusion

Resulting characteristics show, that the use of synthetic immittance elements with current conveyors is possible in the circuit structures of frequency filters and brings certain advantages. The main advantage is the possible use at higher frequencies. The theoretical design method is not very complicated [6].

On the other side, final results also present issues, which can occur in the design. Passive low-pass in the circuit of second order active low-pass can change the position of cut-off frequency. The main disadvantage is commercial unavailability of current conveyors. These active elements can be practically used only as a part of certain integrated circuits. Only three-port positive non-inverting current conveyor of second generation (CCII+) is practically available [7]. Despite these facts, synthetic immittance elements with current conveyors appear very perspective.

## Acknowledgment

In the paper, there are the results of the project SP2013/118, which was supported by Student Grant Competition of VSB–Technical University of Ostrava.

## References

- [1] SMITH, K. C. and A. S. SEDRA. The current conveyor: a new circuit building block. *IEEE Proceedings of the CAS*. 1968. vol. 56, pp. 1368–1369. ISSN 0018-9219.
- [2] BRANDSTETTER, P. and L. KLEIN. Applications of Non-Inverting Positive Second Generation Current Conveyor as a Commercially Available Versatile Active Element. In: *Conference Proceedings of International Conference on Signals and Electronic Systems - ICSES-10*. Gliwice: IEEE, 2010, pp. 157 – 160. ISBN 978-1-4244-5307-8.
- [3] BRANDSTETTER, P. and L. KLEIN. Third order low-pass filter using synthetic immittance elements with current conveyors. *Advances in Electrical and Electronic Engineering*. 2012. vol. 10, no. 2, pp. 89 – 94. ISSN 1804-3119.

- [4] HORNG, J. W., Ch.-L. HOU, Ch.-M. CHANG, H. YANG, W.-T. SHYU. Higher-order immittance functions using current conveyors. *Journal Analog Integrated Circuits and Signal Processing*. 2009. no. 61, pp. 205 – 209. ISSN 0925-1030.
- [5] SPONAR, R. and K. VRBA. Synthetic dipole elements with higher-order immittances in frequency filters with current conveyors. 2004. *Elektrorevue*. ISSN 1213-1539. Available at: <http://www.elektrorevue.cz/clanky/04013/index.html>.
- [6] KOTON, J. and K. VRBA. Generalized frequency filter design methods. *Elektrorevue* [online]. 2008, no. 26. ISSN 1213-1539. Available at: <http://www.elektrorevue.cz/cz/clanky/analogova-technika--vzajemny-a-d-prevod/0/zobecnene-metody-navrhu-kmitoctovych-filtru/>.
- [7] SMITH, K. C. and A. S. SEDRA. A second-generation current conveyor and its applications. *IEEE Transactions on Circuit Theory*. 1970. vol. 17, iss. 1, pp. 132–134. ISSN 0018-9324. DOI: 10.1109/TCT.1970.1083067.

## About Authors

**Pavel BRANDSTETTER** was born in Ostrava, Czech Republic, 1955, 1 June. He received the M.Sc. and Ph.D. degrees in Electrical Engineering from Brno University of Technology, Czech Republic, in 1979 and 1987, respectively. He is currently full professor in Electrical Machines, Apparatus and Drives and vice dean of Faculty of Electrical Engineering and Computer Science at VSB–Technical University of Ostrava. His current research interests are applied electronics, microcomputer control systems and modern control methods of electrical drives.

**Lukas KLEIN** was born in Uherske Hradiste in 1984. He obtained Bachelor's degree at Brno University of Technology in field of Teleinformatics in 2007 and then he obtained his Master's degree in field of Mobile technologies in 2009 at VSB–Technical University of Ostrava. He is currently Ph.D. student in distance form at Department of Electronics on Faculty of Electrical Engineering and Computer Science. His research area includes application of modern active elements, especially current conveyors, in electronic circuits.