

## **Curved RFID Tags for Metallic Gas Cylinders**

M. A. Ziai and J.C. Batchelor

This paper is a postprint of a paper submitted to and accepted for publication in IET Microwaves, Antennas and Propagation and is subject to Institution of Engineering and Technology Copyright. The copy of record is available at IET Digital Library

# Curved RFID Tags for Metallic Gas Cylinders

M. A. Ziai and J.C. Batchelor

Department of Electronics, The University of Kent, Canterbury, CT2 7NT, UK.

## Abstract

In this letter, we present a RFID tag antenna designed to fit around the neck of a small gas cylinder and capable of operation at the European and American UHF RFID bands. The design is readable from all directions in the plane of the cylinder neck and is mounted on cheap synthetic rubber (Neoprene) of thickness 2mm with dimensions of 125mm×20 mm. The tag antenna was conjugally matched to the complex impedance of the transponder IC chip.

## Introduction

Radio frequency identification (RFID) in the UHF band has gained considerable popularity in many applications since it provides a long read range, fast reading speed, anti-collision for multiple tags and significant information storage capability, [1,2]. Ideally, tags are attached directly to the surface of the tagged item though this can cause them to be significantly affected by the electrical parameters of the object. The performance of these tags is generally evaluated with read range measurement and is relatively satisfactory when they are mounted on objects with small dielectric constants. However, when mounted on objects with high conductivity such as gas cylinders, tag performance drops rapidly as the distance between the tag and the metal surface decreases, [3]. These negative effects are strongest when the antenna is less than a few millimetres from the metallic surface [4-6]. Several microstrip patch antennas designed to be mountable on metal platforms have been proposed [7, 8]. However these antennas are designed on thick rigid substrates with complicated and expensive manufacturing processes making them unsuitable for tagging gas cylinders. Current practice is to attach hanging tags to the top ring of the gas

cylinder, but this sub-optimal solution is prone to damage during handling and it is difficult to detect the tag from all directions.

In this letter, a conformal tag antenna design mountable around the neck of the gas cylinder is proposed. The antenna comprises a structure placed on a thin flexible substrate, Fig.1. The combination of bent dipole and parasitic elements allows control of both the real and imaginary parts of the tag antenna impedance to achieve a conjugate match with the RFID ASIC impedance (Impinj Monza 3 chip with input impedance of  $35+j230\Omega$  and read sensitivity of  $-15\text{dBm}$ ). The tag is designed for low cost high volume fabrication process, using cheap and widely available synthetic rubber substrates.

### Structure and Design

The structure of the proposed antenna, Fig.1, includes a radiating dipole (element 1) and a parasitic patch (element 2) etched on a thin polyester film (PET) with the RF transponder IC attached across slot 1. Layer 1 is covered with a thin copper coated polyester layer which lies over part of the antenna as shown in Fig. 1. The two layers form the radiating part of the antenna and are separated from the ground plane by a 1.5mm thick synthetic rubber (Neoprene) substrate ( $\epsilon_r = 3$ ,  $\tan\delta = 0.03$ ) making the structure flexible and durable. The antenna dimensions are selected to conjugally match to the microchip complex impedance for maximum power transfer by varying the gap (slot 2) between the radiating patch (element 2) and the dipole (element 1) and by adjusting the parasitic plate position with respect to the feed line (element 1). The tag design is fully planar with no cross connection between layers.

### Simulation, Measurement and Discussion

Full-wave electromagnetic software CST (CST Studio Suite 2008 Software) was used to simulate the tag performance for the following scenarios (i) in isolation, and (ii) on a small gas cylinder neck as shown in Fig.2. Figure 3 shows good stability in the simulated tag resonant frequency for the above mounting

conditions where the band edge is defined by an S11 of -3dB as is usual for RFID tags. The strong fields generated in the slot between the feed line and parasitic patch and the partial ground plane do not interact strongly with the surface below the tag and this helps to reduce loading effects when mounted directly on metallic platforms such as gas cylinders.

The simulated results were validated by fabricating a prototype and measuring read range in four different applications using a RFID reader with an Austriamicrosystems AS3990 UHF RFID reader chip having typically 27 dBm radiated RF power and 3 metre reliable read range.

In the first test application, the dual band tag was attached to large expanded polystyrene tile ( $\epsilon_r = 1.07$ ,  $\tan\delta = 0.0009$ ) with dimensions: 300×300×1mm. In the second, the tag was curved around a 40 mm diameter expanded polystyrene cylinder, in the third, the tag was placed on a large conducting aluminum alloy plate (200×200×3 mm), and in the fourth, the tag was implemented on the neck of a small gas cylinder with a diameter of 40mm. Table 1 lists the maximum read range measured for each implementation in a laboratory environment. The measured read ranges indicate that the tag has good performance on metal. The data in Table 1 indicates that when curved to be conformal with the gas cylinder, the read range reduces by about 14% compared to a tag on a polystyrene cylinder with equivalent curvature. This demonstrates the tag works well on metal even when conformal to a curved surface.

Read ranges for the dual band tag were measured at the European and American operating frequencies of 869 and 920MHz respectively at 10 degree intervals for the tag implemented on a small gas cylinder. Figure 2 shows a plane view of the cylinder indicating the directions of maximum and minimum read range, while the data in Table 2 shows the ratio between the maximum and minimum range is 68% for both the European and American bands.

#### Conclusion:

The read range data presented in Tables 1 & 2 for the design in Fig.1 indicates that the tag presented in this letter has good performance when mounted in air, on metal, and when conformally curved around the neck of a small metallic object such as gas cylinder. The design is thin, durable and flexible making it suitable for low profile tag implementation on small curved objects and the tag is detectable from all angles at both European and American RFID operating frequencies when implemented on a small (40mm diameter) cylinder. The slotted structure of the tag means it is relatively insensitive to substrate loading and hence can be used with a substance such as Neoprene which has a relative permittivity of 3 and a loss tangent of 0.03). Neoprene has the advantage of ruggedness and flexibility, though a less lossy material could potentially further increase the read range of the tag. However, the ranges reported here are useful and were obtained using a commercially available reader.

The designs described here have been filed as patent: P40909GB.

#### Acknowledgement:

We thank Astriamicrosystems for the reader development kit.

#### References:

1. Finkenzeller, K.: 'RFID Handbook: Fundamentals and Applications in Contactless Smart Cards and Identification', 978-0-470-84402-1, John Wiley & Sons, 2003
2. Griffin, J.D., Durgin, G.D., Haldi, A and Kippelen, B.: 'RF Tag Antenna Performance on Various Materials Using Radio Link Budgets', *IEEE Antennas and Wireless Propagation Letters*, 2006, **5**, (1), pp. 247-250
3. Kwon, H. and Lee, B.: 'Compact slotted planar inverted-F RFID tag mountable on metallic objects', *Electron. Lett.*, 2005. **41**, (24), pp. 1308-1310

4. Ukkonen, L., Engels, D., Sydanheimo, and Kivikoski, M.: 'Patch antenna with EBG ground plane and two-layer substrate for passive RFID of metallic objects', IEEE Antennas and Propagation Society Symp., June 2004, Vol.1, pp. 101-104
5. Raunonen, P., Sydanheimo, L., Ukkonen, L., Keskilammi, M. and Kivikoski, M.: 'Folded dipole antenna near metal plate', IEEE Antennas and Propagation Society Symp., June 2003, Vol.1, pp. 848-851
6. Ukkonen, L., Sydanheimo, L. and Kivikoski, M.: 'Effects of metallic plate size on the performance of microstrip patch-type tag antennas for passive RFID'. *IEEE Antennas and Wireless Propagation Letters*, 2005, **4**, pp. 410-413
7. Hirvonen, M., Pursula, P., Jaakkola, K. and Laukkanen, K.: 'Planar inverted-F antenna for radio frequency identification', *Electron. Lett.*, 2004, **40**, (14), pp. 848-850
8. Ukkonen, L., Engels, D., Sydanheimo, A. and Kivikoski, M.: 'Reliability of passive RFID of multiple objects using folded microstrip patch-type tag antenna', IEEE Antennas and Propagation Society Symp., 2005, Vol.2B, pp. 341-344

Corresponding author: J.C. Batchelor

Email: [j.c.batchelor@kent.ac.uk](mailto:j.c.batchelor@kent.ac.uk), tel. 01227 827004, fax. 01227 456084

List of Figures:

Figure1: Tag schematic diagram, dimensions in mm. PET and Neoprene synthetic rubber substrates are 50  $\mu$ m and 1.5mm thick respectively.

Figure 2: Elevation and plan views of conducting cylinder dimensions and conformal tag location. Plan view shows minimum and maximum read directions. Minimum measured range = 65cm, maximum range = 95cm.  
----- Indicates polar read range envelope.

Figure3: Simulated return loss referred to ASIC input impedance. Solid line: Tag in isolation; broken line: Tag on 40 mm diameter neck of gas cylinder as shown in Fig. 2.

Table1: Tag measured read range for four different mounting conditions.

Table2: Tag maximum read range at European (869MHz) and American (920MHz) bands.

Figure1.

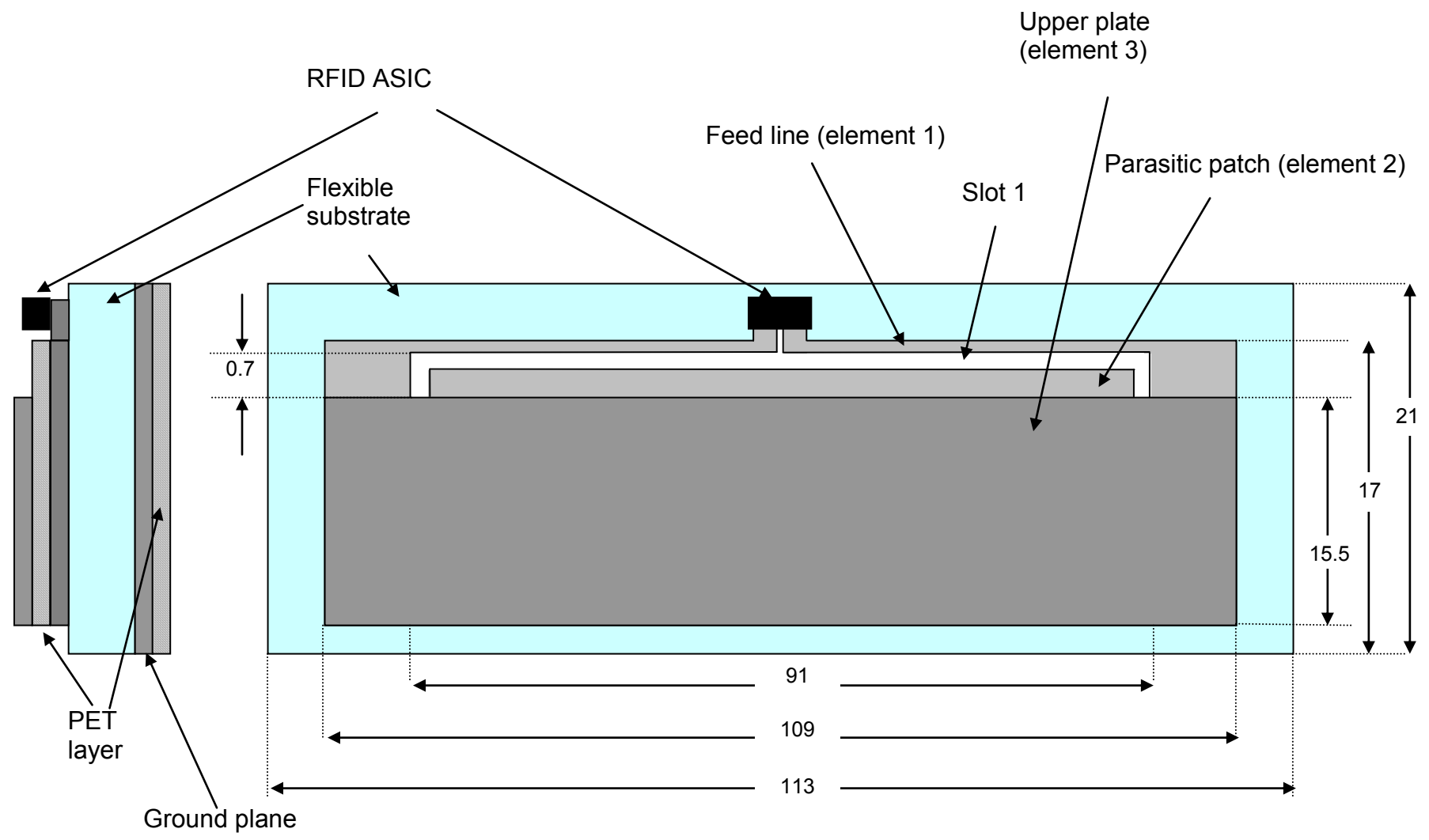



Figure 2.

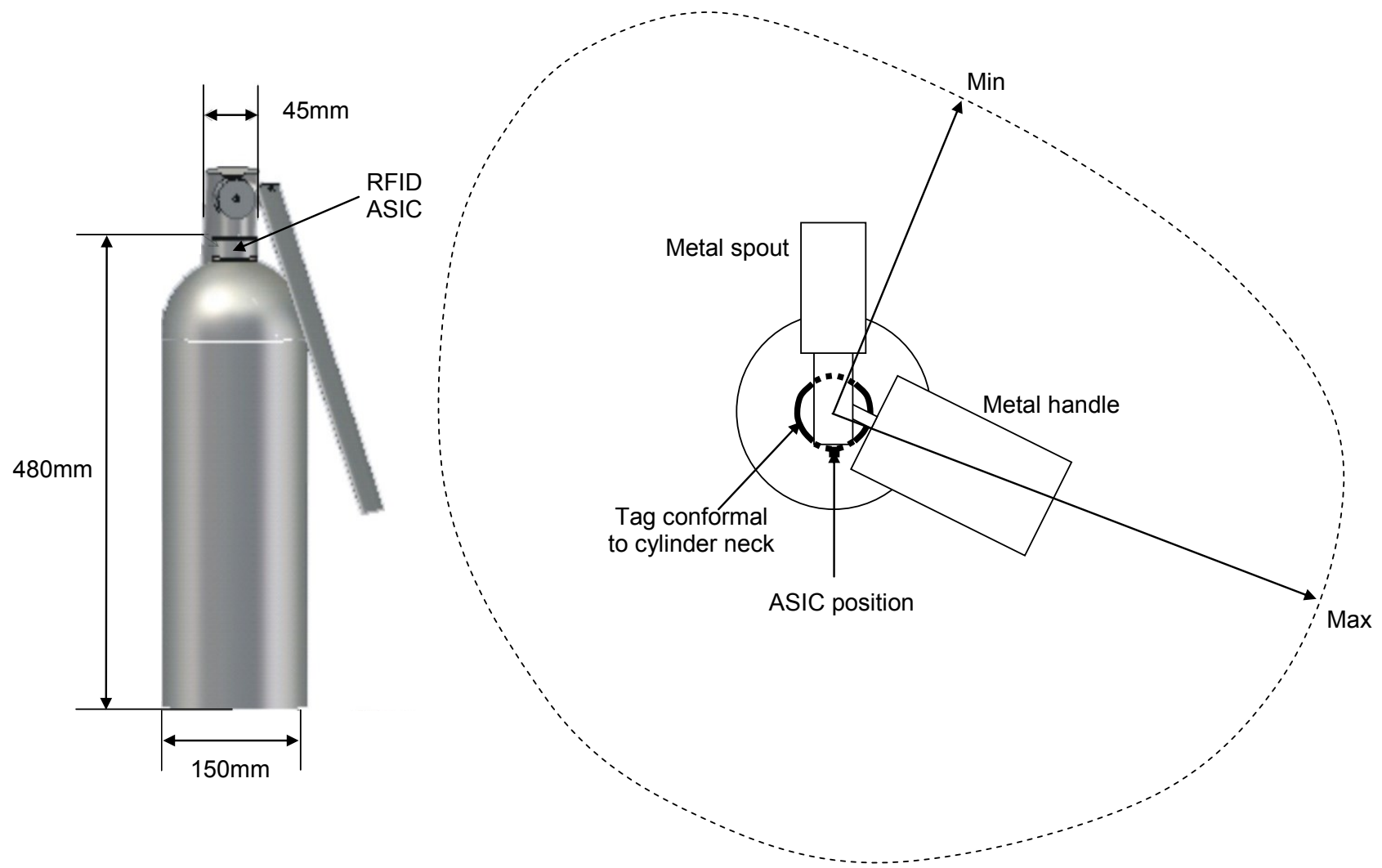
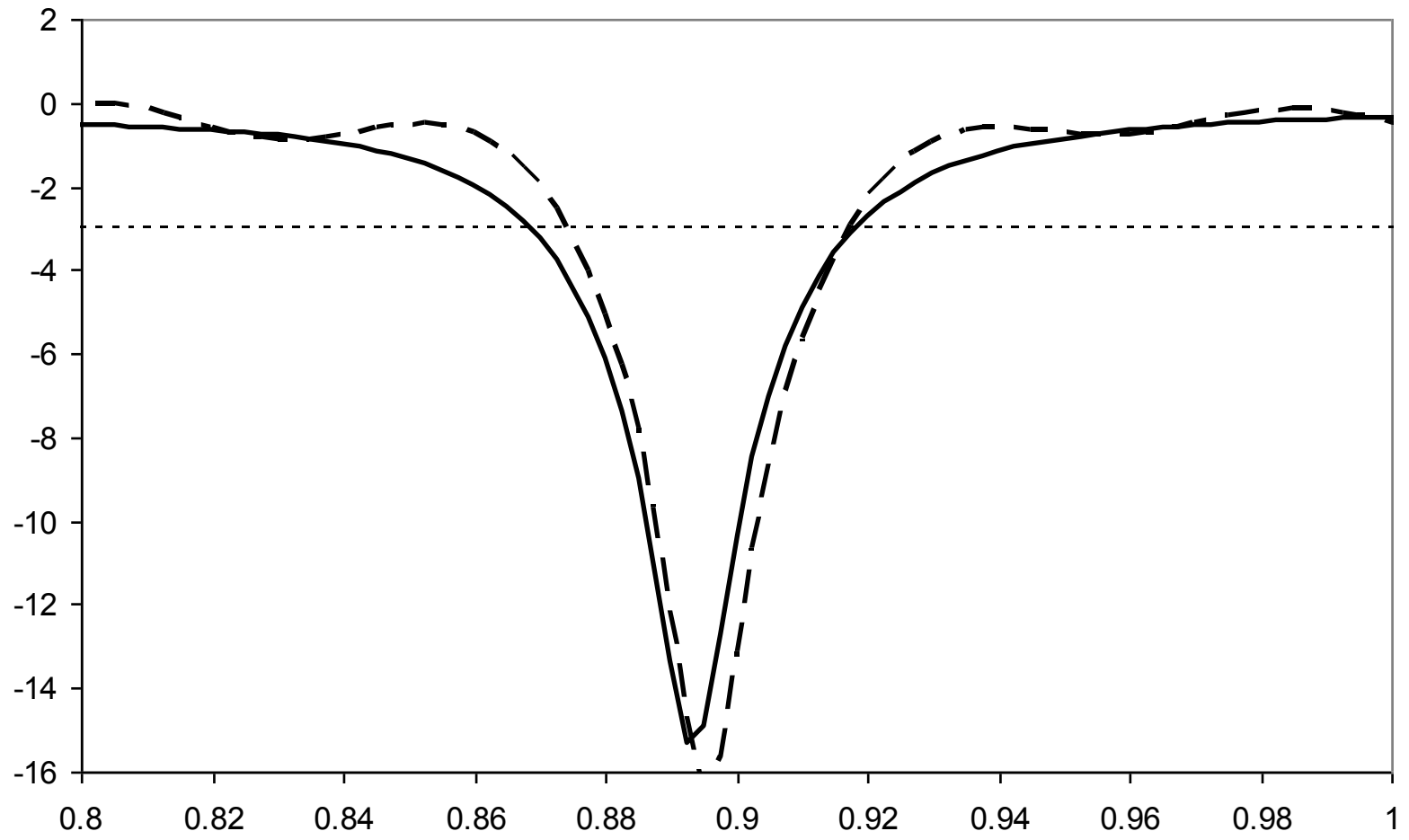

Figure3.



Tag mounting	Read range (m) at 910MHz
Flat tag on polystyrene	3.00
Tag on large flat metallic plate	2.50
Tag curved around a 40 mm diameter polystyrene cylinder	1.10
Tag on gas cylinder 40 mm diameter neck	0.95

Table1. Dual band tag measured read range for four different mounting conditions.

Tag mounting	Maximum read range (cm) at European RFID operating frequency	Maximum read range (cm) at American RFID operating frequency
Tag flat on large metallic plate	230	250
Tag on 40mm diameter polymethacrylate foam	95	95
Tag on gas cylinder	95	95

Table2. Dual band tag maximum read range at European (869MHz) and American (920MHz) bands.