



**European Network of Economic  
Policy Research Institutes**

**ANCIENT**

**Assessing Needs of Care in European Nations**

## **TECHNOLOGICAL SOLUTIONS POTENTIALLY INFLUENCING THE FUTURE OF LONG-TERM CARE**

---

**ANGELO ROSSI MORI (CNR)**

**CONTRIBUTORS: ROBERTO DANDI (LUISS), MARTA MAZZEO,  
RITA VERBICARO, GREGORIO MERCURIO (CNR)**

**QUALITY REVISION: ESTHER MOT (CPB)**

**ENEPRI RESEARCH REPORT NO. 114**

**APRIL 2012**

### **Abstract**

This report provides a forecast of the potential direct and indirect influences of various kinds of technologies on the LTC milieu, answering the following question: from a technology-driven perspective: “Consider each technological solution. What could be its future usage in the LTC sector?”

Future technological deployments will induce changes in the respective roles of the care recipient and of the formal and informal carers, with an impact on three major concerns: the transformation of the care recipient into a proactive subject, the augmented potentiality for home care and the new functions that informal carers could assume.



ENEPRI Research Reports present the findings and conclusions of research undertaken in the context of research projects carried out by a consortium of ENEPRI member institutes. This report is a contribution to Work Package 4-DIV. 1 of the ANCIEN project, which focuses on the future of long-term care for the elderly in Europe, funded by the European Commission under the 7<sup>th</sup> Framework Programme (FP 7 Health-2007-3.2.2, Grant no. 223483). See back page for more information. The views expressed are attributable only to the authors in a personal capacity and not to any institution with which they are associated. The results and conclusions of this paper are those of the author and are not attributable to Eurostat, the European Commission or any of the national authorities whose data have been used.

ISBN 978-94-6138- 187-3

Available for free downloading from the CEPS website ([www.ceps.eu](http://www.ceps.eu))  
and the ANCIEN website (<http://www.ancien-longtermcare.eu/>)

© Copyright 2012 Angelo Rossi Mori (main editor), Roberto Dandi, Marta Mazzeo, Rita Verbicaro  
and Gregorio Mercurio (contributors)

# Contents

---

Executive summary.....	1
Introduction.....	1
Available technological solutions .....	2
Devices and aids .....	2
The phenomenon of ICT.....	2
The synergy between ICT and devices .....	2
Influence of the technology on LTC organisation.....	3
Citizen-centeredness: how to involve citizens and informal carers.....	3
Types of innovative services already possible .....	3
Rethinking roles and tasks of actors .....	4
Systemic benefits and barriers to overcome .....	4
The points of view of citizens, operators and managers .....	5
Meaningful use of data for planning and governance.....	5
Opportunities for the industry .....	5
Obstacles and barriers to innovation.....	5
1. Introduction .....	6
1.1 The future of Technology-Assisted Long-Term Care .....	6
1.2 Fields of Long-Term Care and technologies considered in this deliverable.....	7
1.3 Towards European, National and Regional Strategies on Technology-Assisted LTC.....	7
1.4 Organisation of this deliverable .....	8
2. Direct usage of equipment and devices for LTC .....	9
2.1 Assistive technologies .....	9
2.1.1 Direct usage of the technologies .....	10
2.1.2 Technologies involving the user's environment .....	11
2.2 Users and uses of the equipment in LTC.....	12
2.2.1 The citizens (care recipient and informal carers).....	12
2.2.2 The formal carers .....	12
2.2.3 Other actors dealing with devices in the LTC ecosystem.....	13
2.3 Need for a systematisation of the features of the equipment .....	13
2.3.1 The descriptive features of an equipment to support LTC .....	14
3. The Information and Communication Technologies.....	15
3.1 The management of documentation: EMR, EHR, PHR .....	16
3.2 The influence of the Internet on the care recipients and informal carers.....	16
3.3 The trend towards an integrated information environment.....	17
3.3.1 The ICT solutions are ready to face the LTC needs .....	18
3.3.2 Driving factors for the evolution of the ICT deployment.....	20
3.3.3 Barriers to the wider deployment of ICT.....	21
3.4 The EU initiatives on ICT for health.....	21
3.5 Developing the policies on ICT functionalities for LTC.....	23
3.5.1 Need for a systematisation for policy purposes .....	23

4.	The potential roles of technology in LTC.....	24
4.1	The direct impact of the technology on the care processes.....	25
4.2	The indirect influence of the technology on the LTC context .....	25
5.	The potential direct role of the technologies in LTC provision .....	26
5.1	The combined effect of smart equipment and ICT.....	27
5.1.1	The key rules for a citizen-centred care system .....	28
5.1.2	The effect of technologies on ADL and IADL .....	30
5.1.3	Safe and ubiquitous access to information.....	30
5.2	Opportunities for the technological solutions in LTC .....	31
5.2.1	Examples of care tasks that may be assisted by technology .....	31
5.2.2	Examples of requirements about technological solutions.....	32
5.3	The technology for the engagement of the care recipient.....	34
5.3.1	An opportunity to stimulate the engagement of the care recipient.....	34
5.3.2	The role of technologies to support to self-management.....	35
5.3.3	The engagement of the care recipient.....	37
5.4	The support to collaboration in LTC .....	38
5.4.1	Pooled interdependence of tasks .....	39
5.4.2	Sequential interdependence of tasks.....	40
5.4.3	Reciprocal interdependence of tasks .....	40
5.4.4	Team interdependence of tasks .....	41
5.4.5	The effect of technologies on service management .....	41
6.	The indirect influence of technologies on the LTC milieu .....	42
6.1	Organizational issues in LTC provision .....	43
6.1.1	The systemic aspects of Technology-Assisted LTC.....	43
6.1.2	“Structural Telehealth” as a consequence of a transformation of care processes.....	45
6.1.3	Assessing the contribution of the technology on the outcomes .....	46
6.2	The governance of the correct adoption of the technologies .....	47
6.2.1	Technology-Assisted LTC as enabler for the citizen-centred care.....	49
6.2.2	The Cost-Effectiveness Analysis on the technological applications .....	51
6.3	The evidence of the influence of technologies on healthcare .....	52
7.	Benefits and obstacles related to the Technology-Assisted LTC.....	53
7.1	Potential benefits.....	53
7.2	Challenges and barriers to adoption .....	54
7.2.1	Acceptance of technologies .....	54
7.2.2	Legal clarity and regulations.....	55
7.2.3	Privacy and security .....	55
7.2.4	Connectivity to rural and remote communities .....	55
	Conclusions .....	55
	References .....	58

## List of Figures

Figure 1. To integrate social and health care, all the actors rely on a common substrate for the Management of Information, Communication and Knowledge (MICK).....	18
Figure 2. A typology on technologies for self-management .....	36
Figure 3. A taxonomy of interdependence .....	39
Figure 4. Level of adoption of various forms of technological services .....	48

## List of Tables

Table 1. A list of assistive technologies related to the ADL components.....	10
Table 2. Relevant characteristics of a medical device, which can be adapted to classify any equipment in LTC .....	15
Table 3. Care tasks, activities, technological solutions and actors .....	31
Table 4. Examples of care tasks in various LTC contexts .....	31
Table 5. Examples of requirements related to information management in various contexts .....	32
Table 6. Examples of application of technologies to self-care support.....	37
Table 7. Organisational implications of Technology-Assisted LTC .....	44
Table 8. Examples of evidence base for systemic benefits demonstrated by tele-care applications .....	47

## List of Boxes

Box 1. Selecting the most appropriate LTC tools	11
---	----

# Technological Solutions Potentially Influencing the Future of Long-Term Care

ENEPRI Research Report No. 114, April 2012

Angelo Rossi Mori

With contributions from

Roberto Dandi, Marta Mazzeo, Rita Verbicaro and Gregorio Mercurio\*

---

## Executive summary

### *Introduction*

Work Package 4 of the ANCIEN project seeks to forecast the potential direct and indirect influences of various kinds of technologies on the long-term care (LTC) milieu, and in particular on the potential evolution of the respective roles of the care recipients and of the formal and informal carers.

Therefore the main focus of WP4 is the influence of the technologies on the transformation of the care recipient into a proactive subject, on the augmented potentiality for home care and on the new functions that the informal carers could assume.

In this paper, we work out a technology-driven forecast of the changes on the LTC activities potentially induced by future technological deployments. A second paper deals specifically with the different mechanisms that could realise the potential impact of technology on the LTC sector, based on a comparative analysis of three case studies (dementia, diabetes and obesity) and provides a set of recommendations.

The phenomenon of technology-assisted long-term care is still in its infancy, and must be properly understood and addressed both to maximise its effects on society, and to improve the lives of citizens and their informal carers. An appropriate technological support can make LTC more proactive and coordinated, improving both the quality of life of affected individuals and their families, and the economic sustainability of the overall system: nowadays the holistic health and wellness of the citizen cannot be separated from the appropriate use of technology.

Together, ICT and domotics may deeply influence the rise of new models of care through the connections among professionals, the changing roles of formal and informal actors and of the citizens-patients; the reduction of the functional limitations and the frailness and the reduction of the burden for informal carers. The greatest impact on the LTC system will not be due to the spontaneous and fragmented diffusion of aids among individual citizen-consumers, but rather by large-scale organisational changes of the entire welfare system, supported by the use of enabling technologies, in particular those aimed at chronic diseases, fragility and the ‘healthy aging’.

The full deployment of this ‘ideal world’ is not hampered by the lack of technological solutions, but by regulatory, economic, organisational and cultural problems, by the absence of a constructive debate and a widespread awareness about the available opportunities and above all by the chronic shortage of innovators to manage the change processes within the system.

From a policy point of view, it is important to understand how to influence the change by supporting the chain that moves society from what is possible and available to what is demonstrated to be effective and deserving of dissemination.

---

\* The main editor of this report was Angelo Rossi Mori (CNR). Roberto Dandi (LUISS), Marta Mazzeo (CNR), Rita Verbicaro (CNR) and Gregorio Mercurio (CNR) made substantive contributions. Esther Mot (CPB) performed quality revision.

## ***Available technological solutions***

To describe the main features of the technologies, it is useful to distinguish two general classes: on the one hand are devices and aids and on the other, Information and Communication Technology (ICT). Only then is it possible to consider how to put them together to provide innovative services.

### ***Devices and aids***

The devices used at home are evolving towards a favourable relationship between price and performance; moreover, many tools are being introduced for widespread use by unskilled persons. Usually these technologies have several things in common:

- they are miniaturised, portable, often connected to a PC or a mobile phone;
- they allow for a relatively intuitive and friendly interaction (also considering that perhaps they may be used by an informal carer);
- they have a reduced consumption of energy and can be battery-powered;
- they can be produced on a large scale.

A wide range of commercial solutions can be used to replace, maintain, and improve the functional capabilities of an individual, to assist the delivery of services by operators or to communicate with distant relatives, other patients or operators. Most are passive devices, stand-alone and not necessarily 'electronic': the technological innovation may be hidden in advanced materials, in the production process or in the innovative ergonomic design. The functions are usually limited, tied to a particular problem in a well-defined context; each device is typically designed for a particular function and its specific impact on the 'system' is therefore necessarily limited.

### ***The phenomenon of ICT***

Information technologies are inherently flexible and pervasive, able to manage the acquisition, storage and sharing of data, information and knowledge for different purposes in the delivery of care, in the coordination among the operators, in the integration between social and health aspects, in the management of the facilities. ICT can link the different actors (citizens, informal carers, professionals, managers), and cope with data from a growing number of devices.

Once it has reached a critical mass of solutions, ICT is able to trigger a strong synergy among them, with an ever-increasing systemic effect, giving a new value also to (smart) equipment and devices. However, the change management to introduce 'systemic' ICT solutions involves large-scale organisational transformations and then high-level strategic decisions. It is time to reverse the innovation process: the policy decisions based on LTC priorities should include the selection of the proper technological solutions, integrating whenever appropriate ICT and devices to provide innovative services.

The greatest impact could come from the coordination of actors on the territory, through the various facilities, among themselves and with the citizens, to ensure the continuity of care, the synchronisation among the activities and a targeted communication among the actors. ICT thus acquires a crucial role in the process of reorganisation and redistribution of responsibilities among the operators and between operators and patient/informal carer, e.g. in the integrated management of chronic diseases and in the empowerment of citizens (patient engagement), in the integration between social and health care.

### ***The synergy between ICT and devices***

The combination of ICT and devices overcomes the space-time obstacles, with a potentially high direct impact on LTC. Solutions are evolving to incorporate the ability to manage and communicate information through the Internet, such as in the case of home automation (either for monitoring or for comfort). Home devices involve new care services as a structural component, as they will require (public or private) contact centres to manage the interpretation of data from the equipment, to provide an adequate return to citizens and informal carers, and to assure the technical support for maintenance of the equipment and to troubleshoot connection problems. The technologies could play also an

important indirect role over time, by modifying the future pattern of impairments faced by LTC, as they can decrease the risks for frail people, reduce the consequences of accidents and delay the complications for chronic patients.

Close to a necessary technological infrastructure and basic services for ‘technical’ interoperability (hardware, software, secure networks, master index of citizens and care professionals, electronic cards, etc.), it is necessary to develop and maintain a reference ‘info-structure’.

The Info-structure defines systematically, in a coherent manner at regional, national or international level, a series of packages with the details about the potential content to be shared between applications in a number of predictable contexts. For each context, the definitions of the expected actors, their tasks and roles, with the data elements and the coding schemes involved, are then made available in a format suitable for electronic processing, both for systems developers and for the users, to allow for the optimal functioning of the overall system. It should be specific to the social and health sectors, to achieve the effective ‘semantic interoperability’ (i.e. a meaningful and complete communication among operators and citizens), but also to create a common language for the managers and the policy-makers to deal with the technological solutions and their role in LTC.

### ***Influence of the technology on LTC organisation***

#### ***Citizen-centredness: How to involve citizens and informal carers***

Putting ‘the citizen at the centre’ means that in principle the social and health services should appear to the citizen as an integrated and coherent team of professionals. Thanks to the information system, the data about the citizen should circulate among the professionals according to the individual plan of care: information about their roles and goals, and about ongoing and completed tasks and activities.

Citizen-centredness also means an increased opportunity for patient engagement and ‘self-management’. Citizens and informal carers will therefore become an integral part of the whole care system, by promoting the ability of citizens (and their families) to manage effectively their health. In practice, citizens with informal carers may be increasingly involved in the proactive management of their care, to deal with home devices and to correctly interpret information to decide about their own care or to communicate effectively with the formal carers.

For each technological service their collaboration may be of various types:

- purely passive role – the technology (such as environmental sensors) allows remote monitoring by operators, ensuring privacy and dignity of the person, with virtually no active participation by the citizen.
- limited participation – the role of the citizen or informal carer is precisely structured and includes the performance of simple repetitive tasks, perhaps after a learning phase; a common example is the generation of a request for intervention.
- interactive collaboration – the equipment and the services where the citizen or informal carers use their knowledge to interact with the formal carers and take joint decisions.
- autonomy – after specific training, a number of citizens and informal carers may be enabled – as appropriate – to self-manage some devices and autonomously take some decisions in predefined circumstances, under an operator’s supervision of the overall process.

From the point of view of technology, there will be relatively self-consistent solutions (including aids and non-electronic devices), which enable citizens to better manage their daily activities or their disease, or provide guidance on the execution of exercises (e.g. for early forms of dementia or for rehabilitation); other systems may connect to the internet, transmit data or facilitate the interaction with remote operators (often named as “Telehealth”), in addition to face-to-face interactions.

#### ***Types of innovative services already possible***

Notwithstanding the important role of research to develop advanced solutions, several technology services are already feasible today. Even if they are still not yet used optimally, they allow:

- access to current information on the available LTC services and on the procedures to obtain them, to reduce the time lost in the administrative steps (to download forms, to submit requests via the internet, to get information on the progress of ongoing steps);
- a citizen to enjoy a greater continuity of care, thanks to an information system that facilitates the collaboration of the operators among them and with him/her and the informal carers;
- a citizen and his informal carers to manage (also online, safely) his personal health information, to report problems to operators, to manage the agenda and the deadlines, to receive recalls and warnings on the correct use of medications or to perform measurements, to improve data capture with an immediate assessment of data quality in relation to the parameters already measured;
- access to authoritative knowledge in different languages (on diseases, medications, procedures, etc.) and to suggestions for an appropriate use of health facilities, providing audio-visual aids, including interactive educational tools for the execution of activities by the citizens, for example motor rehabilitation or changes in life styles;
- access to tele-company services, in order to permit citizens to talk to operators, relatives, friends or people with similar problems; to improve comfort, for example, automatically turning on lights, controlling temperature and the air conditioning of a room; to provide an automatic reader of texts or colour recogniser to the blind; to improve security through environmental surveillance and possibly generating reports of faults and alarms.

As already mentioned, some of these aids are devices purchased independently by families; other services are provided through public or voluntary organisations. However it would be extremely useful for citizens, families and decision-makers in the care organisations, to receive an independent consulting service on how to select the most suitable aids.

### ***Rethinking roles and tasks of actors***

Technology can massively impact on long-term care by significantly altering the relations now existing among the various actors. Technology can:

- alleviate the dependency of individuals, by directly impacting the impaired functions and by promoting home-based care. The care recipients maintain their autonomy by staying in an environment familiar to them and being able to be reintegrated into the community;
- ease the burden on informal carers, through services supporting their activities and – if applicable – improving their opportunities to return to work;
- improve the safety and the timely recognition of adverse events, through environmental surveillance and by reducing the risks of inappropriate behaviour;
- slow down the evolution of a chronic disease and mitigate the effects on quality of life of the patient and the informal carer – especially by avoiding transitions to hospital care – by supporting the healthcare process (Disease Management, Chronic Care Model);.

Technology can empower each member of the ‘virtual team’ around the recipient of care by letting him perform more complex tasks than before. In fact it may produce a greater efficiency because it may help improve the division of labour between players. For example, partially self-sufficient individuals may have the opportunity to perform safely a greater number of routine tasks, with less support from other actors. This may reduce the hours required of the formal or informal carers. Similarly, informal carers, with the help of technology, may assist or replace professionals in managing several tasks, possibly with remote professional supervision.

### ***Systemic benefits and barriers to overcome***

The technological solutions available today can significantly help improving the quality of life of citizens and their informal carers, allowing many of them to re-establish partially or in full their active role in the community. This goal requires a strong systemic integration between health and social resources, together with voluntary organisations.



### *The points of view of citizens, operators and managers*

The use of appropriate technology can allow citizens and informal carers to enhance their skills in self-care, to increase the adherence to prescribed therapies (in particular drugs), to reduce waiting times and visits and to decrease morbidity and mortality.

As for operators, they can perform a more intensive follow-up without visiting homes. Operators may reduce their isolation by improving their links with other colleagues; they can improve their workload with less compromised patients and reduce the risk of errors.

Managers can better cope with shortage of staff, by managing human resources more flexibly. Also they can ensure greater equity in access and a more appropriate use of services, by reducing waiting lists, avoiding hospital admissions (and particularly by reducing inappropriate access to emergency rooms). Technology may also encourage earlier discharge of patients with the guarantee of a quality management of home care.

### *Meaningful use of data for planning and governance*

The use of data for multiple purposes increases their completeness and quality; in fact the integrated management of the same data in different contexts ensures:

- reliability. Data are entered once by those who generate them, for their own goals, and then re-used several times (even by different properly authorised players), improving the quality controls, their implicit ‘credibility’ with respect to the context and also their accuracy.
- efficiency. It avoids having to retype the data already known to the system (also avoiding typing errors), while the data involved for sharing can be continuously synchronised.
- timeliness. All the data useful to the tasks in progress can be made easily available on-line or retrievable by authorised personnel.
- friendliness. Data can be selected, summarised and presented in the most appropriate format to each authorised operator and for each different task.

Data generated during the care processes are a key input for planning resources and activities and for ensuring a quality management system able to continuously improve its performances. The more information systems at all levels of care are integrated, the more the governance of the system and the quality assurance may be effective.

### *Opportunities for the industry*

Industry involvement in LTC is still largely underdeveloped, mainly to the inadequacy of the demand side, which is highly fragmented and with specific difficulties in entering into long-term programmes.

Technologies are often an issue directly left to the patient-consumer. Unlike other technologies (e.g. diagnostic technology in health care), LTC technologies are still not adequately integrated into the care processes and in the daily activities of operators; on the other side, policy-makers are not yet able to produce effective plans embedding a meaningful use of the technologies.

### *Obstacles and barriers to innovation*

Different obstacles are slowing down the process of change. The technological solutions should be selected downstream of strategic decisions on the models of care, and the main barriers to technology adoption are due to the leadership (or lack of) or to an organisational inertia and not to the specific technology. Other barriers are related to privacy and security, coherence with the regulatory system and the issue of data management accountability. Most of the obstacles that arise from the connectivity in remote areas seem now to be overcome, even for the fact that it is possible to obtain significant results even with the exchange of a small amount of data. Finally, the resistance to technology seems also to have been overcome, thanks to the growing friendliness of the interfaces, although it is still quite critical for an elderly person in the absence of a skilled informal carer.

# Main Report

---

## 1. Introduction

Technology is becoming a pervasive resource in every sector of our lives. In particular, after the mechanical and chemical revolutions, which transformed the production of goods in our environment, technology – and in particular Information and Communication Technologies (ICT) – is deeply changing our world, with mobile communication, advanced home appliances (for leisure and comfort) and information processing.

Work Package 4 of the ANCIEN project seeks to forecast the potential direct and indirect influences of technology on the long-term care (LTC) milieu, and in particular on the potential evolution of the respective roles of the formal and informal carers.

In this paper, we deal with issues related to various kinds of technologies with a specific focus on the opportunities to support LTC activities and to forecast the changes potentially induced by future deployments.

A separate but related paper adopts a problem-driven approach and copes specifically with the different mechanisms that could realise the potential impact of the technology on the LTC sector, based on a comparative analysis of three case studies (dementia, diabetes and obesity).

### 1.1 The future of technology-assisted long-term care

Technology is able to provide an aid to citizens, clinicians, social workers (e.g. by low-tech tools, intelligent equipment, Electronic Patient Records, portals for citizens and professionals, administrative services) and also to managers, for epidemiological and planning purposes (secondary uses of the information). Therefore it could deeply affect the organisation of LTC provision.

We call this approach “technology-assisted long-term care”. In fact, a correct deployment of modern technology is not important per se, but it is becoming an essential factor to cope with the sustainable (and integrated) evolution of the health and social care sector, especially in the LTC environment. A similar concept is clearly expressed for example in the introduction of the yearly report on “Research and Development Work Relating to Assistive Technology” by the UK Department of Health (2010), which focuses on “*the potential to use technology-enabled services to address the budgetary challenge of providing more care with less funding*”.

Note that in most cases the technological equipment should not be considered important per se, but rather as the technology-enabled services that may be provided through them, including all the organisational aspects and the human resources involved (considering also the role of the recipient and informal carers). To this end, we consider the following statements:

- Several pieces of equipment (mainly low-tech tools) were already introduced in the LTC sector to alleviate the impairment and to improve the safety of the care recipient. They are largely independent from each other; in most cases, each of them results in an improvement of the adaptation of the individual to a single aspect of the ADL and IADL; however, each of them, *per se*, does not provoke a large *systemic* effect on the organisation of the LTC milieu. The penetration is pervasive and the phenomenon is mature: it is difficult to imagine a more significant change in the near future, apart from a more complete deployment and a more effective selection of the most appropriate services.
- The increasing synergy between the Information and Communication Technology (ICT) and the home-based advanced equipment – which can be expected to grow further in the next years – may reach the effect of enabling effective and innovative care models, i.e. it could facilitate the management of deep changes in the care organisation and in the respective roles of all the formal and informal actors (including the beneficiary), that could avoid or delay impairment, reduce the frailty and alleviate the burden on informal carers.

- The phenomenon of technology-assisted long-term care is only in its infancy and should be adequately understood, regulated and governed to maximise its effect on the society, both in terms of improving the quality of life of the care recipients and their informal carers, as well in terms of achieving an economically sustainable evolution of the LTC field.

The evolution of this phenomenon cannot be spontaneous or (only) bottom-up. Clear and consistent policies and strategies for the development and adoption of appropriate technological solutions, within a robust framework, could support the engagement of voluntary organisations, social enterprises and SMEs throughout the care community, allowing them to compete in the marketplace alongside larger conglomerates and national and international businesses.

## **1.2 Fields of Long-Term Care and technologies considered in this deliverable**

Specifically, if the questions do not specify otherwise, LTC in the ANCIEN project includes services necessary over an extended period of time, i.e. chronic in nature or more than 6-months in duration, for the population 65+ in the following fields:

- palliative care
- long-term nursing care
- personal care services
- home help and care assistance
- services and financing in support of informal (family) care
- residential care services other than nursing homes
- other social services provided in a long-term care context

LTC in the ANCIEN project does not include:

- services of curative and rehabilitative care or
- LTC services connected with congenital chronic disabilities or chronic disabilities that existed at a younger age.

However, other conditions and situations will be considered in this paper, when it is possible to envisage a potential impact of the technologies that may indirectly influence the future evolution of LTC provision, e.g. technologies applied to the care of chronic diseases, that could change the forecasts for the prevalence of the different kinds of disabilities (and of their levels) and thus the subsequent needs for LTC, or enabling technologies that could be essential to the introduction of innovative organisational models, offering an opportunity to induce a rearrangement of the respective roles of the various LTC actors (recipients of care, informal and formal carers), able to improve quality and sustainability of the LTC system.

As will be described in detail in sections 2 and 3, for the purposes of this paper, all possible kinds of technologies will be considered. In particular, the discussion will include for example the low-tech technologies for personal usage (such as for example adaptive utensils for feeding or shower seats), the smart home devices able to measure and transmit data, the equipment for the environment (e.g. motion-sensor security lights, sensors of gas, smoke or water). Special attention will be devoted to the information and communication technologies (ICT) and their direct and indirect usage by the care recipient, the informal carers, the formal carers and the managers.

Furthermore, the indirect actions that could have consequences on the level of awareness and appropriate adoption of the technologies – in the sense just described – will be considered.

## **1.3 Towards European, national and regional strategies on technology-assisted LTC**

National and regional agencies should play a role in “shaping policies and programmes” to make the most benefits from the technological developments for both individuals and society, within the

constraints of an economically sustainable evolution. The other stakeholders can assist these agencies to properly assume their guidance role, by working out and harmonising the requirements and the consequent technological solutions across the various problem-oriented objectives/priorities of the health and social care sectors.

They should contribute to delineate the criteria to assess the priorities and the technological, cultural and economic feasibility, and eventually the criteria to define and monitor the comprehensive initiatives to support in a coherent way the different items of the action plans concerned with LTC.

The European Union activated a series of initiatives, which today show frequent duplication: see for example the Ambient Assisted Living Joint Programme (AAL, 2011), the activities on ICT for better Healthcare in Europe coordinated by the “ICT for Health” Unit of DG INFSO (European Commission, 2011b), the e-inclusion Programme (2011), the activities of DG REGIO (2011) on good practice on ICT and Ageing solutions, and the specific studies by the European Commission’s Joint Research Centre (JRC) of the Institute for Prospective Technological Studies (IPTS, 2009 and 2011). In addition, two recent strategic workshops addressed very similar topics:

- the European Science Foundation Exploratory Workshop on “Social Care Informatics and Holistic Health Care” at Keele University in the UK, in July 2010 (Rigby, 2010) and
- the OECD-NSF Workshop on “Building a smarter health and wellness future” in Washington, D.C., 15-16 February 2011 (OECD-NSF, 2011).

Eventually, to bring all the above activities into a comprehensive framework inside the Digital Agenda for Europe (European Commission, 2011a), the European Commission is organising a new modality of work, named “European Innovation Partnership on Active and Healthy Ageing” (EIP-AHA, 2011).

#### **1.4 Organisation of this paper**

In the next two sections, we introduce the main features of the technological solutions.

With respect to the field of LTC, we should distinguish two complementary domains:

- the artefacts that act on specific functions, e.g. a wheelchair, an aerosol therapy device, a hearing aid or a sensor of movement; and
- the tools to manage information and communication that can cope synergically with multiple requirements and goals: most countries and regions are entering the ‘connected health’ era with explicit Action Plans and with the strong support of the European Commission.

In section 2 we present the first kind of technology. In the field of LTC, it includes all the assistive equipment and medical devices that directly deal with the impaired functions of an individual, as well all the clinical devices used by healthcare professionals and the equipment for surveillance and signalling alerts.

An array of complex equipment is more and more being developed and adopted, which embed functions of information processing and communications capabilities. For example, common to both domains is all the modern equipment considered in the realm of domotics (for measurements, alarms, surveillance, comfort of daily activities), which nowadays are increasingly connected to networks for remote control and communication.

The second kind of technology, described in section 3, includes all the services involving the management of information and knowledge. Their recording, storage, retrieval and communication is carried on by several actors (e.g. the individual, the informal carers, the professionals, the managers), together with the management of the data that are generated or used by an increasing number of the above pieces of equipment.

The progress in the electronic management of information and communications and the increased performance of home equipment may facilitate the introduction of dramatic changes in the organisation of health and social care. In particular, technological solutions could assist the move

towards a more sustainable care system, to effectively transform the care provision towards the community, by supporting more independent living and reducing unnecessary hospitalisations.

In section 4 we then introduce the discussion about the direct and indirect influence of the technologies on future LTC provisions, which is then expanded in sections 5 (direct influence) and 6 (indirect influence).

Finally, in section 7 we summarise the benefits and the obstacles to innovation, related to the introduction of the technologies in the LTC milieu.

## **2. Direct usage of equipment and devices for LTC**

We initially discuss separately the two main areas of support, as described in section 0: from the one side, the equipment (Assistive Technologies and Medical Devices) in section 2, and from the other side the information and communication technologies (ICT) in section 3.

However the most relevant phenomenon (and offering the greatest potential impact on LTC) is nowadays due to their increasingly close integration. Together, they are able to reduce the need for assistance by formal and informal carers and delaying the severity of the impairments. The potential future implications of this synergy will be discussed in sections 4, 5 and 6.

### **2.1 Assistive technologies**

A study by the AARP (formerly, the American Association of Retired Persons, <http://www.aarp.org/>) showed that 34% of adults over 65 in the US have an impairment that limits one or more basic physical activities (CTA, 2009a and 2009b).

Those impairments may be compensated by one or more pieces of equipment, out of a large set of commercially available solutions. Most of them are passive, stand-alone appliances, where the technological innovation is hidden for example in the materials or in the ergonomic shapes.

Electric/electronic devices could be used to improve the adaptation of the environment to the particular defective functions, e.g. in ‘smart homes’ or ‘smart cities’ (e.g. with sound-emitting traffic lights).

Several technological solutions are available and could be deployed among professionals and citizens to effectively support the delivery of long-term care, but they have not yet been successful as expected. During the few last years, advanced home devices, based on a promising international standard [Continua Health Alliance, 2009] were appearing near the traditional low-tech tools; they are increasingly becoming affordable, friendly (connected to the internet network for data exchange) and remotely controlled.

Assistive technologies include a wide range of tools and equipment that are used to increase, maintain or improve functional capabilities of individuals with disabilities. While assistive technologies are able to mitigate the effects of acquired impairments, other equipment can be effectively used to improve the management of care and to slow down the consequences of the chronic conditions that affect most elderly people.

Mobility assistance technologies, such as power wheel chairs, wheelchair lifts, posture optimisation devices, breathing assistive devices and neuro-prostheses, help older adults cope with the loss of motor function and help them get around and minimise assistance from an informal carer.

Fall detection technologies actively or passively evaluate whether a fall has taken place and alert others that an individual has fallen. The goal of fall-detection technologies is to distinguish falls from ADL and then contact who can quickly assist the individual. Fall detection systems can be active, passive or a combination of the two and include personal emergency response systems and passive sensors.

Assistive listening equipment, including hearing aids, helps overcome deterioration of hearing senses by enhancing hearing in noisy environments. Examples include personal frequency modulation (FM) systems, infrared systems, induction loop systems and one-to-one communicators.

Visual assistive equipment helps older adults perform daily tasks with minimal assistance. Such technologies include video and screen magnifiers, text-to-speech equipment, and larger-sized equipment like a phone with enlarged numbers.

### 2.1.1 Direct usage of the technologies

The amount of assistance needed to perform ADLs varies from person to person depending upon strength and range of motion, functional abilities, health status and medical diagnosis and precautions.

The following table provides a non-exhaustive set of examples of equipment, arranged by the kind of ADL aspect to which they refer. They act directly on the individual, allowing for some increase in the degree of autonomy and often reducing the need for a continuous presence of an informal carer.

*Table 1. A list of assistive technologies related to the ADL components*

<i>Lower body dressing.</i> Includes putting on and taking off any clothing item from the waist down. When dressing the lower body, persons with a paraplegic level of injury might find it helpful to use a combination of alternative techniques and adaptive equipment. The most commonly used adaptive equipment includes e.g. dressing sticks or elastic shoe laces.
<i>Upper body dressing.</i> Includes putting on and taking off any clothing items from the waist up. If a brace is worn around the torso, loose garments with front closures are suggested. Additionally, wrinkle-resistant clothes allow for easier application and neat appearance.
<i>Toileting.</i> Includes the ability to pull down clothing in preparation for elimination, cleaning of the perineal area and pulling clothing up after completion. Examples of tools include toilet aid to reach perineal area or leg straps to assist lifting legs.
<i>Bathing.</i> In the first few days or weeks following injury, the persons will most likely sponge bathe from bed. Once they are medically stable, the occupational therapist will train them to shower safely. The tools that could assist with safety and completion of the bath include tub chairs with a back, transfer boards or mechanical lifts.
<i>Grooming.</i> Tasks include brushing teeth, washing face, combing hair, shaving and applying make-up. The necessary equipment includes long handled brushes or the universal-cuffs to hold toothbrush, razor, make-up, etc.
<i>Feeding.</i> Like upper body dressing and grooming, this is usually not difficult for a person with a paraplegic level of injury. This activity, however, can be difficult for a person with a tetraplegic level of injury. There are several splints and pieces of adaptive equipment available to assist with this process, including non-skid bowls or adaptive utensils.

*Source:* Adapted from the Family-friendly-fun website, 2011.

Most of the tools considered in the above table are simple tools with a low level of technology or with the technology hidden in the materials, in the production process or in the design of the shapes.

Normally they are not to be considered as a component of a more complex ‘technological service’ (as discussed in the next sections) and the usage of these kind of tools has little systemic impact on the care system as a whole; in other words, they don’t imply a different organisational model, while the choice to reimburse or not the device depends on an economic decision.

Most of them are already available in the market and may be either purchased by the family (as consumers), either covered by the public or private insurance system as a component of their duties.

*Box 1. Selecting the most appropriate LTC tools*

The issue is to select the most appropriate tools for each individual and to provide understandable instructions for their appropriate usage. At a meta-level of support,

- the care recipient or the families could be assisted in the selection of the devices best fitting with the individual needs and with the user environment;
- the decision-makers in the insurance companies, voluntary organisations or of the public system could be informed about the comparison of the costs and benefits of similar tools.

The ICT meta-support can be – and actually is – in the dissemination of the information about the available equipment (comparative tests, vendors, prices, etc.) or on the management of a web-based shopping gallery.

The reference information about the equipment could be set up and maintained at national (regional) level, for a distributed set of centres using the same information source.

A European coordination centre, even in the presence of local differences in the marketed products, could be an opportunity for more independent evaluations and comparisons, to improve the documentation to describe the potential support available for the different kinds of impairments, to facilitate the establishment of a European market for the products, to exchange news and assessments of the tools among the national and regional centres.

Examples of active orientation centres are the network established by the Centre National Référence Santé à Domicile et Autonomie in Nice (France) (<http://www.cnr-sante.fr/le-cnr-sante/>) and the CERCAT – Centro Regionale di Esposizione, Ricerca e Consulenza sugli Ausili Tecnici, in Cerignola (Italy) (<http://www.cercat.it/home-page/il-progetto.html>).

Examples of Living Labs are CASALA – Centre for Affective Solutions for Ambient Living Awareness – in Dundalk (Ireland) (<http://www.casala.ie/casala-living-lab.html>) and SOFTEC – Swedish Open Facility for Technology in Elderly Care – in Orebro (Sweden).

The new technologies have the potential to change the state of affairs, by an appropriate usage of the ICT functionalities to develop additional performances of smart devices, triggering a synergic process. The following example about ‘eating’ is among several provided by (Tak et al., 2010) and involves the integration of sensors, wireless information transfer and decision guidance systems:

Sensors for assessment, monitoring, and detection; information transfer and decision guidance systems for evaluation and planning.

Example: The bathroom scale detects weight changes of a resident and sends the information to rehabilitation equipment, such as a treadmill, which customizes the resident’s weekly exercise program.

A menu-planning program simultaneously increases or decreases the daily calories and fat in a resident’s customized daily menu plan and sends the information to the kitchen. Weight and oral intake information is sent directly to the resident’s electronic medical record.

### **2.1.2 Technologies involving the user’s environment**

As a complement to the tools for direct personal usage, the technologies (in a broad sense) could assist in the design of an ‘accessible home’, for example (adapted from the Family-friendly-fun website, 2011):

- Outdoors: motion-sensor security lights, wheelchair ramps, raised gardening beds, keyless locking systems and barrier-free entrances.
- Bathroom: anti-scald faucets and showers, entry-platform tubs, shower seats and pocket doors.
- Kitchen: low-level work surfaces, accessible appliances, easy-open cabinets and accessories.

- General living areas: handrails, wide, non-slip steps and floor surfaces, easy-operating electrical switches and outlets and hands-free door handle.

Most of the concepts are increasingly applied to new buildings and are conveniently usable by all people, from small children to physically impaired elderly people.

The effect of the technology consists not only in modifying the approach to care provision, allowing for more independence and safety, but it also affects a complementary sector (in this case, the buildings industry).

The ICT meta-support described in the previous section applies also to this kind of equipment.

## 2.2 Users and uses of the equipment in LTC

In the realm of LTC, we must distinguish between two kinds of users of the equipment: “end users” or “indirect users”

- citizens (care recipient and informal carers) and
- formal carers, i.e. health and social care professionals.

### 2.2.1 *The citizens (care recipient and informal carers)*

For the purposes of this paper, the most important actors involved in the usage of the equipment are the care recipients and their informal carers.

The field of home appliances is developing fast, with powerful, ‘smart’, relatively cheap equipment that can be remotely controlled by care professionals. As far as medical devices (subject to specific regulations) are concerned, the main usages could be, for example:

- to assist the care recipient in ADL or IADL, by replacing or supporting the defective functions;
- to support the performance of the care activities, e.g. rehabilitation;
- to provide surveillance and generate alarms, by suitable sensors on the body; and
- to perform periodic clinical measurements.

In addition to the above medical devices, other equipment should be considered in the ecosystem of the care recipient, which may be used for example for safety and for participation to the life of the community, perhaps not necessarily included within the scope of the European Directive on medical devices:

- equipment that provides tele-company, i.e. to talk with professionals, remote family members/ friends or other people with the same health issues (a kind of social network);
- equipment that provides surveillance of the environment and/or generate alarms;
- domotic equipment to improve the comfort (e.g. automatic lighting, control of the room temperature and air conditioning).

Dealing with the equipment directly used by the citizens, particular attention should be given to consider also **the complementary services that could be required to complete the process around the equipment itself**, i.e. the services that – whenever applicable – should be in charge of the maintenance, the calibration, the remote control, the interpretation of the data and the reaction to the alarms. According to the type of equipment, the type of service and the local regulations, each service could be either provided by the care system or be dealt with directly by the citizens.

### 2.2.2 *The formal carers*

The formal carers are the other important category of end-users in the LTC milieu. They can use the medical devices (directly or by a remote connection) for different purposes:

- to support LTC provision;



- to provide health care, including the execution of clinical measurements at home or their remote interpretation; and
- to manage surveillance to limit the risks or for a prompt intervention.

About the ontology of the devices, in general the formal carers may be interested in classifying the devices according to the care recipients' needs and diagnostic/therapeutic method, e.g. to organise access to the information on a website and to perform comparisons of quality and effectiveness.

### **2.2.3 Other actors dealing with devices in the LTC ecosystem**

The proper management of the devices involves several other parties, among which are:

- managers and administrators of the care facilities and
- health authorities and competent authorities.

The devices have an impact on the routine activities performed by the managers and the administrative staff within a care facility, including logistics, quality control, and planning.

The administrators of the facilities need to have access to an inventory of their medical devices; therefore they may be interested in the properties of the devices themselves (materials involved, sizes available, modifications, hazard warnings, devices for a given treatment) to manage orders and invoices.

The managers should organise their views on the devices according to all the above dimensions, as well as the ones more related to care provision.

Summarising the administrative needs, the tasks could be:

- administrative management and purchase of the equipment
- keeping and maintaining the inventory of medical devices according to the regulations
- information top management of the available stock and its value
- assure the provision for materials of daily use of the equipment.

The technical staff manages an inventory of the equipment, maintains them and proposes their replacements. Its tasks include:

- the technical management of equipment
- to keep record of compulsory/voluntary re-checking and re-calibrations
- to keep record of trainings
- to be able to report and receive incidents/accidents and do the necessary arrangements
- to keep record of technical state of equipment
- to keep record of the accessories and of materials necessary to operate the equipment.

The authorities have regulations for quality control that, among other things, may require the systematic training of staff in the use of medical devices, and regulations for procuring, installation, use, service and disposal of medical devices.

In a comprehensive perspective on the LTC environment, ICT could assist the above actors in performing their tasks, to improve the organisational aspects, the overall quality of the system and its effectiveness.

## **2.3 Need for a systematisation of the features of the equipment**

In order to work out the potential impact of the equipment on LTC, the features of the groups of equipment should be explored, and thus groups of similar equipment should be aggregated according to a set of criteria, specific for each application context.

The lack of an agreed systematisation and appropriate clustering of the types of equipment can cause several problems. It may, for instance, be difficult to maintain a nomenclature and coding system, to translate a nomenclature from one language to another, to identify similar equipment and to carefully describe their common features. This issue is problematic for the effective management of a common European website with the information on the devices and their comparison.

Most of the equipment used in health and social care fall under the EU regulations for “medical devices”. The Directive 2007/47/EC (which amends the original medical device Directive, i.e. 93/42/EEC) provides a precise definition of medical device:

any instrument, apparatus, appliance, software, material or other article, whether used alone or in combination, including the software intended by its manufacturer to be used specifically for diagnostic and/or therapeutic purposes and necessary for its proper application, intended by the manufacturer to be used for human beings. Devices are to be used for the purpose of:

- Diagnosis, prevention, monitoring, treatment or alleviation of disease.
- Diagnosis, monitoring, treatment, alleviation of or compensation for an injury or handicap.
- Investigation, replacement or modification of the anatomy or of a physiological process
- Control of conception

This includes devices that do not achieve its principal intended action in or on the human body by pharmacological, immunological or metabolic means, but which may be assisted in its function by such means. (European Commission, 2007)

In Europe, the medical device Directive has been in force since 1 January 1995. This introduced a new situation for all parties involved with medical devices. Market approval of a medical device is based on common regulations (the directives) and standards; certification – when needed – of products and/or processes, is done just once by a notified body in any of the EU countries by choice of a manufacturer.

As a consequence a ‘Medical Device Vigilance System’ is in charge of the national health authorities. Serious accidents and malfunctions which could lead to incidents shall be reported to the authorities, which shall investigate whether the regulations of the medical device Directive have been fulfilled by the product involved. The data collected as a result of this requirement are to be disseminated to all EU member countries in an effective and secure manner.

Existing nomenclatures for equipment used for medical devices enumerate up to 10,000 medical device groups. There is no generally recognised way to organise these medical device groups across the different nomenclatures; therefore each nomenclature implies a different way of organising the devices, particularly concerning small subsets of medical device groups, selected for special uses.

A specific nomenclature, based on a suitable ontology, should be developed for the equipment influencing the LTC field, possibly endorsed at European level.

### **2.3.1 The descriptive features of an equipment to support LTC**

The CEN standard ENV 12611 “Medical Informatics - Categorical structure of systems of concepts - Medical Devices” (CEN, 1996) defines the systematic features that should be used to characterise a medical device group, i.e. a set of devices that present similar behaviour and share the intended purpose.

The ontology provided by this standard could be the starting point to characterise any equipment and tool used for LTC purposes, if integrated with the other dimensions that are specific for the field.

The main criterion to gather together a group of similar equipment is the ‘base concept’, e.g. panic button, pacemaker, catheter and bandage.

One or more features may be made explicit to differentiate one group from another with the same base concept, e.g. for the LTC applications it could be relevant to consider the context of use, the level of

automation, or the ability to be remotely controlled, the intended user (the care recipient, an informal carer, a professional) and the skill required. Increasingly important is the ability of smart devices about data processing and data communication with a home computer or a smartphone.

Several types of equipment are conceived to be used directly by the care recipients or by the informal carers, at home. Most equipment is designed to deal with a specific problem.

The technical principle or the method, and the constituent material, are in principle less relevant for the purpose of the present paper. Increasingly important from an organisational perspective is instead the way the equipment is controlled (e.g. if they allow for remote control by a professional).

The most relevant dimensions to describe a device according to the CEN standard are presented in the following table.

*Table 2. Relevant characteristics of a medical device, which can be adapted to classify any equipment in LTC*

<b>semantic link</b>	<b>associated categories</b>
performs	<device function>, <procedure>, <care activity>
has-target	<body component>, <body fluid>, <body function>, <surgical structure>, <health problem>, <personal role>, <age group>, <environmental component>, <organism>, <Medical Device>
has-context-of-use	<speciality>, <location>, <position>, <patient's context>
is-based-on	<technical principle>, <method>
has-constituent	<material>, <device component>
is-presented-as	<presentation form>, <physical state>.
has-specification	<sterilisability type>, <reusability type>, <flexibility type>, <control type>, <power source type>, <temporal type>

Source: CEN, 1996.

### 3. The Information and Communication Technologies

As a complement of the equipment and devices, the other kind of technology that could be expected to have a large effect on the Long-Term Care context is the ICT.

While the 1990s were the time of the ‘Information Society’, during the last decade the progress of Communication Technologies (namely the internet) was particularly pervasive in every domain. Together with the progress on equipment, ICT has the potentiality to dramatically change the world of LTC, if the related ‘eHealth’ phenomenon (or, better, the ‘Connected Health’) will be correctly understood and controlled: *“more informed patients are more empowered people”* (Department of Health, 2006).

In particular, ‘telehealth’ (i.e. the remote application of eHealth) has already started to show its benefits, demonstrating that this sector is mature for a wide application also in LTC.

The major influence of telehealth is seen in chronic disease management and on tele-company. More than 80% of patients reported satisfaction with these remote services, better capability to manage their care and measurable improvements in clinical outcomes and hospitalisations (Chien et al., 2011) and thus also on LTC provision.

The eHealth solutions provide several mechanisms to intervene directly in the healthcare processes and indirectly in the LTC environment, e.g.

- Capture data and information (from the user, or from the equipment: measures, signals, images);
- Store/retrieve data, communication, access to knowledge for organisational/administrative purposes, for decision support); and

- Process data, compare, summarise, produce indicators to improve quality and optimise the allocation of resources.

### 3.1 The management of documentation: EMR, EHR, PHR

There are several major classes of healthcare technologies that have contributed to shifting the healthcare system focus from disease to patients. The first group consists of interoperable systems that are citizen-centric data management systems that aim to aid the daily processes of patient care:

- Electronic medical record (EMR): Captures the patient's medical story for the purposes of a provider. It enables also an easy communication of patient data among healthcare professional, even if often it is not connected to others system outside the enterprise and patients do not have access to these systems.
- Electronic Health Record (EHR): Complete record of patient encounters, across all the providers and facilities. In principle, it is accessible under appropriate policies of privacy and security by any authorised actor from any location, at any moment. It is a record in digital format that is capable of being shared across different healthcare settings, by being embedded in network-connected enterprise-wide information systems.
- Personal Health Record (PHR): Web-based system that empowers patients with access to their own health records. PHRs are often kept separately from the healthcare institutions data. Examples of PHRs are "My HealthVet" of the Veterans Health Administration (2011), "My Health Manager" of Kaiser Permanente (2011) and provider-independent initiatives, such as Google Health and Microsoft Vault.

The electronic social record is not yet in common use, but it looks like an obvious future extension of the previous ones. The evolution of the PHR (integrated with the social record) may be particularly relevant for a more effective proactive role by individuals and their informal carers in the proper management of long-term care.

### 3.2 The influence of the internet on the care recipients and informal carers

In principle, the health ICT allows the care recipients to access their electronic medical records, viewing laboratory results, medication lists and other parts of the medical record, but they rarely provide easy access to the notes written about them by doctors.

The growing care recipients' desire for greater engagement in, and control over, their own medical care, is driving innovative pilot projects.

The citizen-oriented eHealth tools on the internet have the potential to help people to manage more effectively their health and health care. The internet can provide information about diseases and their management, health education, chats and debates (among patients or professional or both), or spread medical news. Moreover care recipients can share experiences and get information about their illness or therapeutic method.

The internet may have a disruptive effect on the traditional paternalistic relationship between care recipients and physician, by reducing information asymmetries, as the internet is now the most widely used health information resource. However, a number of websites are not reliable or are influenced by hidden commercial purposes. In addition, little is known about the distribution and use of different kinds of eHealth tools across the population or within population subgroups.

Many blogs provide commentaries or news on a particular subject; others function as more personal online diaries; however, blog authors have few incentives to maintain their credibility and integrity or, in contrast, to compromise it for the sake of ratings or sales. The prevalence and visibility of blogs provide a new route for health communication and contributes to the public perceptions of the health care professions. The widespread of public health information and messages have been associated with changes in personal behaviour, such as reduction in smoking prevalence or increased condom use.

Medical blogs provide a new route for communicating substantial, evidence-based health information to the public. Many blogs emphasise positive elements of the practice of health care. Nurses and physicians facing challenges or isolation at work use blogs and online communities to connect to others who can provide advice and support.

In summary, the internet is a new resource that could have a relevant impact for LTC recipients and their careers, in terms of authoritative websites, individual blogs and – of course – social networks, especially to fight isolation of informal carers. There are also negative effects to be monitored, for example, the risk of improper use of the excess of (often unreliable or biased) information.

### **3.3 The trend towards an integrated information environment**

The next step about the eHealth phenomenon may be to move forward a comprehensive Health Integrated Architecture which would include all the back off systems, better known as Health Information System (HIS) embedding many sub-systems such as: patient accounting, patient management, payer system, Clinical Information System (CIS) used by nurses and doctors, and so on.

To this extent, the longitudinal Electronic Health Record systems would give physicians and staff the ability to document patients' encounters, streamline workflow and share information with appropriate parties such as other physicians or staff. Unlike other systems, it would encompass data relating to all patients' encounters, including diagnoses, orders, result, discharge instruction, etc.

The trend is towards an increase in friendly integration among the different applications and the equipment, thanks to suitable standards; eventually in the future a significant and seamless integration of data, information and knowledge will be obtained. Furthermore, each kind of user (including not only the formal carer, but also the individual and the informal carer) is expected to be able to manage the portion of the data corresponding to his/her role, purposively organised in order to effectively carry out the respective tasks.

The LTC milieu cannot remain outside this phenomenon, including the recording of the routine assessment of the ADL and IADL scales, the consequent regular updates of the LTC plans and the suitable recording of the performed LTC activities.

However, it should be noted that until now technological innovation in the health sector has proceeded at varying speeds among the application areas, and within each area, as a result of different dynamics of diffusion, receptivity, adoption and sustainability (Fichman, 1999; Bradley et al., 2004; Greenalgh et al., 2004; Tamburis, 2011).

Each Health Care Organisation (HCO) should consider an incremental development of a continuum of coherent elements that would interact with each other, aligned with the corporate strategies and connected to the revision of their clinical and organisational processes; moreover, today the entire process should be facilitated and coordinated at the level of wide jurisdictions, with a clear definition of the distribution of roles between HCOs and the respective authorities or eHealth consortia, e.g. about common infrastructures for data exchange within the jurisdiction and across jurisdictions.

The final achievement, depicted below in Figure 1, will consist of the appropriate integrated management of organisational, administrative, clinical and social information, and in the friendly links among individual data (administrative procedures, management of the equipment, electronic health and social record), local and universal resources (e.g. portals with practical information and universal knowledge) and social networks.

The ongoing and future reorganisations of LTC processes, especially related to the increasing care recipient engagement about chronic diseases or frail and dependent subjects (i.e. with citizens becoming more responsible for their health status and lifestyles), asks for a 'systemic' deployment of ICT services (e.g. Berwick & Nolan, 1998; Tsinakis et al., 2002; Anderson & Funnell, 2005; Rossi Mori, 2007b and 2009). This phenomenon requires a strong political and managerial support, to enable cultural and environmental changes with a deep involvement of all the stakeholders. A greater effort is therefore requested to develop suitable strategies and models towards a stronger cooperation among

the provider organisations and a better governance of care processes by means of detailed indicators for quality and appropriateness (Rossi Mori, 2007a, 2007b, 2008b).

Figure 1. To integrate social and health care, all the actors rely on a common substrate for the Management of Information, Communication and Knowledge (MICK)

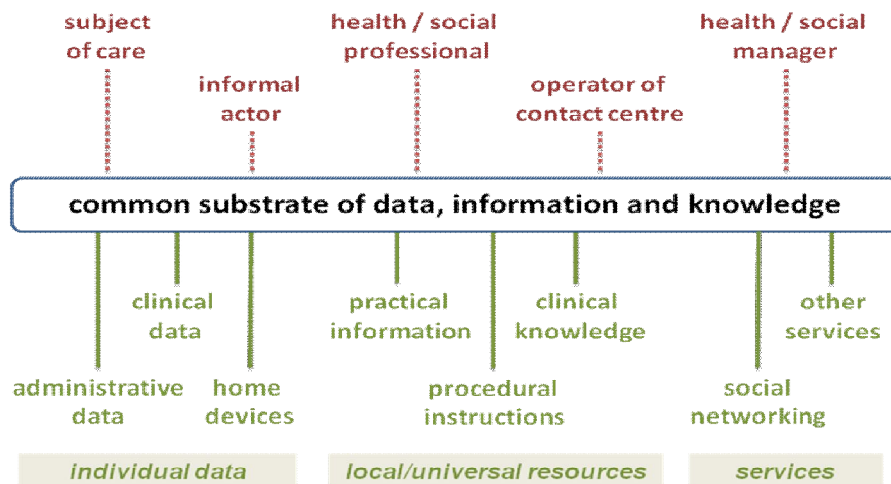

Source: Rossi Mori et al., 2009.

In the last few years, eHealth is expanding the capabilities of healthcare professionals by providing accurate and timely information and expert support (Seaton, 2007), arriving at the idea of “Connecting for Health” (National Health Service of England, 2005), “Health Connect” (Australian Department of Health and Ageing, 2008; Kaiser Permanente, 2008), and “Connected Health” (OECD, 2008).

Far from being a simple change of name, it represents the natural consequence of a new perspective, whose focus doesn't rely on the technological solutions, but rather on people's health: health and social care organisations should “behave as a coherent system” thanks to the integration among all the information resources, designed and centred on the citizen. The main driver should be an economically sustainable evolution of the sector within each jurisdiction, based on the planning priorities on health and social care, to accomplish the citizen's welfare (Rossi Mori, 2007c).

### 3.3.1 The ICT solutions are ready to face the LTC needs

As a basic infrastructure, a Master Index of the LTC recipients (subject to an informed consent) can be made accessible to all the relevant actors, parallel with a Master Index of the healthcare patients, with the aim to provide the most appropriate care in the most appropriate setting, to achieve an increased multidisciplinary integration among social services, mental health services, primary and secondary care, based on individualised care plans and a local menu of services.

The increased capabilities of computerised devices and the speed of broadband connections have created new opportunities to improve care provision; by using the available technologies, a proactive system of care for LTC recipients and their informal carers can be designed and developed: “Offering more ways of delivering support and (self-)monitoring at home reduces the amount of time people need to spend in hospital or travelling to outpatient clinics and offers the opportunity of a more effective self-care. This is both a cost saving and an important method of improving the quality of life for people who are living with long-term health conditions” (Department of Health UK, 2008).

The expected outcomes and benefits of a correct use of technological solutions include:

- improved management of citizen-specific multidisciplinary teams;

- an increase in planned and preventative activity, leading to a reduction in reactive interventions, resulting in better outcomes for the care recipients and better working days and professional satisfaction for health and social care operators;
- an emphasis on self-management skills and on the role of informal carers, supported by an improved capacity in integrated primary care and community services to manage LTC care;
- joint health and social care planning and delivery with appropriate third sector involvement; and
- improved health and well-being for LTC recipients, with better clinical outcomes and quality of life.

According to (Rossi Mori, 2007b), the deployment of technological solutions in the health and social care sectors has been mostly driven so far by a ‘Ptolemaic’ attitude, i.e. with the technology in the centre and limited organisational changes arranged around them. We assume that a ‘Copernican’ attitude will be adopted in the future, i.e. one centred on the care strategies of a jurisdiction and on the actual individual care processes, with the design of the suitable technological solutions as a consequence.

The bottlenecks for a successful penetration of ICT are related to non-technological factors in the deployment of a care plan, to support continuity of care, cooperation among professionals and effective communication. The drivers for change are the local decision-makers and the appropriate leadership among the health and social care operators. This evolution should involve at the same time all the actors of entire jurisdictions, with a deep commitment of the top decision-makers.

The management of the innovative models of long-term care requires not only the practical support by the Ptolemaic technology-driven solutions, but mainly the diffusion of the proper organisational components of the Copernican strategy-driven action plans.

A severe obstacle will be the lack of an adequate number of innovators embedded in the care facilities, to support the professionals and the citizens in the effective management of the technology in general, and in particular in the meaningful use of the information and communication, as well as of the home equipment.

Co-operability among the formal carers (and with the citizens) on long-term conditions, involves:

- The capture and the timely availability of the specific data items needed by each professional to perform his/her tasks in a particular moment, i.e. depending on the context of the care provision (condition of the care recipient, kind of facility, task within the care plan, etc.). The maximum benefit can be obtained when one deals with clinical and social situations that are considered to be predictable.
- The production of a ‘baseline profile’ for each condition of the care recipient, i.e. a small set of relevant, stable all-purpose data, to describe the background state of the care recipient (i.e. not reporting about a particular contact) with regard to a specific condition/health issue (Rossi Mori, 2008b). For example, a baseline profile for an oncology patient (related to the stage of the disease), a profile specialised for the diabetic patient or a profile to describe the overall status of an elderly care recipient.

The above targets require developing and disseminating structured knowledge and coding schemes, in a format suitable for computer processing, called ‘infostructure’, which includes the following components:

- The toolkits to formalise, distribute at the national/international level and customise for the local context a set of authoritative “reference care plans” (starting from the most relevant long-term conditions) to provide generic guidelines on the mutual responsibilities of the professionals, the care recipient and the informal carers, to make explicit their expected information and communication needs along the nodes of each reference care plan.

- The task-specific datasets, i.e. explicit lists of the data items either to be captured and stored for a particular task, or to be communicated when transferring responsibility in a care plan, or to compute indicators for audit/governance.
- Earmarked terminological subsets, i.e. situation-oriented value sets (terms and codes) able to fit with each field of a task-specific dataset, together with a toolkit to specify and maintain them, as well as to maintain the cross-relations with general-purpose reference nomenclatures (e.g. with ICF, SNOMED CT, nursing terminologies).
- Precise guidelines for a formal carer to uniformly perform the (new) professional acts that generate the diverse variants of the so-called Patient Summaries (e.g., the Baseline Profiles extracted from the care recipient record; the summary of a period of care; the “letter to a colleague” on a particular health issue), to feed the future integrated Longitudinal EHR, or the Shared Social and Health Record to support the modern delivery of care.

**In summary**

The development and maintenance of a specific infostructure  
is an essential prerequisite  
to facilitate the dissemination of the ICT solutions in the LTC milieu.

The developers of the ICT solutions will use the infostructure  
to provide the semantic interoperability among the applications,  
while the end-users will be able to express themselves  
in a more precise and agreed way, with comparable terms.

In turn, the managers will be able  
to extract data expressed in a coherent way and aggregate them  
to build quality indicators and to perform comparisons.

### **3.3.2 Driving factors for the evolution of the ICT deployment**

Three driving forces are interacting over technology in the arena of health and social care (Rossi Mori, 2009):

- The first driving force is the market. It is most intrinsically linked to the history of healthcare devices and healthcare informatics. Several products and services were gradually expanding across facilities, and the scale of deployment and contracts was slowly increasing.
- The second driving force is derived from the Ptolemaic attitude. In several countries, the national/regional policies promote the appropriate diffusion of medical devices and the inter-sectoral eGovernment actions endorse the adoption of common ICT architectures and infrastructures.
- The third driving force is derived from the Copernican attitude. It originates from the health and social care milieu, i.e. from the national and regional policies and thus from the related priorities on the Health System (e.g. the National Plans for prevention, for oncology, for mother and child, for social care, for Healthy Ageing, ...).

**In summary**

During the last 10 years there has been an increasing awareness  
that the scale of the phenomenon has been moving  
from the level of the individual healthcare facility  
(and the spontaneous evolution of the market)  
to the social and health care at the level of large jurisdictions,



asking for an intervention of the authorities to take care of the processes by setting up appropriate guidelines, regulations and governance instruments.

In various countries, the eGovernment plans started to cope with this new challenge, mainly through the development of common basic infrastructures across multiple sectors (e.g. broadband or electronic signature).

The third driving force, specific for the healthcare sector, has not yet been exploited as needed (Gartner, 2009). In principle, it should take into account the trend to cope with the extreme fragmentation of care activities and to point towards a change of focus from hospitals for acute conditions to the management of chronic conditions in the territory. It is expected to provoke a deep rethinking of the care models and a reconstruction of the unity of actions about the care recipient (e.g. by shared plans for continuity of care), with a stress on prevention, primary care and, in particular, chronic disease management and social care integration. This transformation could be facilitated by an intense usage of eHealth solutions.

In several countries, innovative healthcare programmes are directed to put into practice the clinical evidence already accumulated on the most relevant chronic conditions (e.g. Maggini et al., 2008; Wagner, 2002a), which require approximately three-quarters of the healthcare resources and a continuous commitment by the care recipients and their families. Nevertheless, rarely are those programmes (which involve education, self-auditing, governance & enhanced communication) the kernel of the technological innovation in the sector.

The action plans to reorganise the system of health and social care may involve a massive reallocation of resources, but the appropriate deployment of technological solutions is a secondary issue within this change process, even if they can be a key factor to enable the change itself. In fact, the reorganisation of the care processes may be (and hopefully will be) facilitated by a pervasive adoption of technology. It can positively impact on decision processes of professionals and the lifestyle of citizens, and thus may modify their behaviour, improve quality, optimise expenditure, increase appropriateness, as well as reduce medical errors and duplication of procedures.

### **3.3.3 Barriers to the wider deployment of ICT**

Despite the many advances in technology, deployment has lagged behind. The barriers originate at different levels and are associated with a multitude of technological, cultural, legal, political and market related factors (European Commission, 2008).

These barriers include, among several others:

- Acceptance of ICT solutions, especially if they are introduced into the care processes by technology-driven approach. New roles for health and social professionals, new skills and new actors (e.g. telehealth call centres) appear in the process of care delivery. Understanding and implementing these changes in an acceptable and coherent manner is essential to enable wider deployment.
- Technical issues and resistance in the market deployment. A prerequisite, requiring early investments, is the production of a secure infrastructure. Significant efforts were addressing the need for interoperability and standardisation; the efforts on the info-structure are still inadequate for large-scale, multi-context deployments.

### **3.4 The EU initiatives on ICT for health**

In 2004, the Commission adopted the communication “eHealth – making healthcare better for European citizens: An action plan for a European eHealth Area” – COM(2004) 356 final, 30.4.2004 (known as the eHealth action plan), which invited member states to adopt pilot actions to accelerate the beneficial implementation of eHealth.

An explicit deadline was agreed: “By the end of 2008, the majority of European health organisations and health regions (communities, counties, districts) should be able to provide online services such as teleconsultation (second medical opinion), ... telemonitoring and telecare.”

However, even with the regular dialogue among member states, held under the i2010 sub-group on eHealth, this objective is still far from being met.

On 7 May 2008, during the eHealth High Level Conference in Portorož, a Declaration<sup>1</sup> was approved by the heads of delegations of the 27 EU member states. It explicitly underlined the urgency of ensuring a wider deployment of ICT solutions, and in particular of telehealth services, to meet the challenges healthcare systems are facing.

Within the overall goals of the Lisbon Strategy, the strategic i2010 initiative – a European initiative for growth and employment – builds on ICT policies, regulation, research and innovation.

The key priorities of this policy are promoting a supportive and competitive environment for electronic communications and media services, reinforcing research and innovation in ICT and ensuring that an inclusive information society has benefits for all.

The recent mid-term review of the i2010 initiative identified eHealth as “a good example of how ICT innovation can serve overarching European policy goals”; among the actions listed is the implementation of the “Lead Market initiative” in eHealth.

On 4 November 2008, the Commission adopted a Communication on “Telemedicine for the benefit of patients, healthcare systems and society” COM(2008) 689 final.<sup>2</sup> Telemedicine (used as a synonym of telehealth) is a component of ICT services, currently underdeveloped but with a potential high impact on the health system. The Communication on telemedicine proposed a set of actions aimed at enabling wider deployment of telemedicine services, focusing on three main priorities: building acceptance of telemedicine services, bringing legal clarity and facilitating market development.

In June 2009, a “staff working paper” SEC(2009)943 final, with the same title of the above Communication, was published to provide additional information on the topic. The staff working paper expands on certain aspects of the Communication, such as the outcome of the extensive consultation phase that was undertaken in preparation for the initiative, the policy context and the legal aspects. It also illustrates with concrete examples how wider deployment of telemedicine can affect individual patients, healthcare systems and society.

The general context that gave rise to the telemedicine communication and this staff working paper is that European healthcare systems are under increasing pressure from societal challenges, in particular as a result of the following issues: changing demographics combined with growing prevalence of chronic diseases, shortages in human resources in healthcare and increased demands from patients for more quality in the provision of healthcare services. In addition, the European economy is at a critical point in delivering growth and jobs to European citizens. Innovative approaches are needed to help address these major challenges. Within this challenging context, healthcare costs are increasing rapidly, posing fundamental questions on how to achieve sustainable and equitable healthcare systems in Europe.

There is evidence that, when combined with proper organisation, leadership and skills, telehealth and innovative Information and Communication Technologies (ICT) can help to address some of the societal challenges to Europe’s healthcare systems. Their benefits range over different levels:

- At the level of the individual, eHealth can support improvements in a patient’s health and quality of life, particularly for those with chronic diseases, by enabling safer monitoring at home and reducing the number of hospital visits. Care recipients can remain in their familiar environment

---

<sup>1</sup> The declaration is available at

[http://ec.europa.eu/information\\_society/activities/health/policy/ehealth\\_conf/index\\_en.htm](http://ec.europa.eu/information_society/activities/health/policy/ehealth_conf/index_en.htm)

<sup>2</sup> See [http://ec.europa.eu/information\\_society/activities/health/policy/telemedicine/index\\_en.htm](http://ec.europa.eu/information_society/activities/health/policy/telemedicine/index_en.htm)

and community networks, thus minimising the social disruption they may suffer in addition to the impairment of their health.

- For healthcare systems, eHealth may contribute to a paradigm shift in the way healthcare is delivered and can help to address the shortage of care professionals, particularly in sparsely populated areas, and can improve the efficiency, quality and timeliness of care service provision.
- eHealth solutions may contribute to the growth of the European economy. That is a global market that is expanding rapidly and is expected to continue enjoying high growth rates in the years ahead.

Member states are supportive of the beneficial deployment of eHealth. However, despite this support and the considerable level of technical maturity of different technologies, the sector is not as well developed as could be expected, also because it failed to tackle the core business of the care processes. To face them, a Ptolemaic attitude is no longer suitable and a Copernican attitude is not yet put into practice.

In the next section, we will consider the opportunities arising from the adoption of equipment and/or ICT in the LTC environment, especially if they are properly embedded as essential components of a suitable programme to deploy an effective organisational change.

### **3.5 Developing the policies on ICT functionalities for LTC**

Given the complexity of the field, a care system is not always capable of coping with an over-accelerated and ‘over-technological’ approach to the ICT topics to satisfy at the same moment three strategic goals:

- high quality assistance processes and safer professional decisions,
- supporting a sustainable evolution of the care sector (i.e. high quality/low expenses) and
- effective and appropriate access to the services for the citizen.

Achieving an effective alignment of the strategies, on any wide jurisdiction, is strictly linked to the critical dynamics of interrelation existing between the main drivers of ICT penetration in the health and social care sector, namely the drift velocity within spontaneous markets, the e-government plans, and the change processes introduced by the initiatives that satisfy the planning of the health and social care systems (e.g. Spanjers, 2001; Tamburis, 2006; Rossi Mori et al., 2007b).

The consequence is the unbalanced growth of the ICT adoption dynamics. Too centralised ICT action plans and the lack of explicit and detailed common strategies proactively involving all the stakeholders may bring two main consequences:

- Health and social care professionals may feel reluctant towards informatics solutions conflicting with the traditional organisation of care processes, showing scarce interest and cooperation, and providing incomplete and poor quality data in the health or social record; and
- the local care organisations may have a passive attitude towards innovation, giving up any proactive behaviour (especially concerning the care processes) and defusing the internal qualified personnel competences.

The discussion about the policies within a jurisdiction, and the comparison between the policies in different jurisdictions, requires a common language based on the adoption of a robust common nomenclature.

#### **3.5.1 Need for a systematisation for policy purposes**

The ICT solutions are encompassing all the possible needs of information management of the care organisations and of the citizens. In a not-so-far future, it would become natural to consider a unique information environment, including health and social care.

As described in the previous section about the equipment, also in the field of ICT functionalities there is a lack of an agreed ontology and a consequent universally recognised nomenclature. A preliminary step to build an ontology on the ICT solutions for LTC could be to develop a reference taxonomy.

The taxonomy developed for the healthcare field by (Tamburisi, 2011) could be expanded to include a specific nomenclature for the LTC field. It considers two complementary perspectives:

- Functions (F), meant as services of which different kinds of actors (citizens, social/health care operators, managers, administrative staff) can take advantage; and
- Enabling Components (C) that are not providing direct services to the different actors, but stand as the qualifying prerequisites to deploy the Functions and handle the change.

According to this taxonomy, the Functions may be categorised into three macro-areas, depending on the typologies of users and their activities:

- F1: Functions directly regarding citizens, such as participation and access to the care services;
- F2: Functions directly regarding the operators, related to prevention, assistance and care; and
- F3: Functions directly regarding the care management, quality improvement and optimisation of resources.

The Enabling ICT-related Components could feature as well three macro-areas:

- C1: Basic technological infrastructures,
- C2: Application services and
- C3: Organisational elements related to change management and governance of the ICT deployment.

The C1 and C2 macro-areas are the prerequisites to support most of the functions. The C3 macro-area should concern the readiness of each health and social organisation towards an effective governance of the ICT phenomenon.

#### 4. The potential roles of technology in LTC

In this section, we introduce an important distinction between two different mechanisms by which the technologies may influence the future of LTC provision: a direct impact on the care processes vs. an indirect effect on its context.

By the direct mechanism, which will be the topic of section 5, in the immediate future, the technologies may produce an impact on the life of the recipient of care: they may alleviate the burden of the present impairments on the individual and on the informal carers, handle risk control for the frail elderly, promote the independent living.

They may support an improved daily management of the long-term conditions, allowing a healthier and more active life and increasing the opportunities for the informal carers and perhaps the care recipient to recover an adequate role in the community. Specifically relevant for the ANCIEN project are the self-management tools.

The indirect mechanism, which will be discussed in section 6, is complementary to the direct influence and involves many ways to ‘change the context’ in the short period and – most important for a forecast – in the medium-long term.

Actually, the modification of the context may happen by acting either on the local organisational factors (e.g. by optimising the ongoing care provision and the allocation of resources) or at the level of a large jurisdiction (e.g. by acting on policies and regulations that will promote the deployment of large scale, systemic technology-enabled services).

From another point of view, the technologies may have an impact on the evolution of the chronic diseases, a relevant problem for the health of European citizens and the most resource-consuming

sector in health and social care. New models of care, such as the Disease Management and the Chronic Care Model, are being introduced to face the increasing requirements of this sector, to improve the outcome of the healthcare processes on the chronic diseases (see for example, The Joint Commission, 2008; Illinois Health Connect, 2010; Chien, 2011; and UK Department of Health, 2011). It demonstrated how to be able to avoid hospitalisations, to reduce the complications and to alter the prevalence of the related disabilities, i.e. to reduce the consequences of the disease on the ADL and IADL.

In this sense the introduction of innovative **technology-enabled care models** may have in the future a strong long-term impact on the Long-Term Care sector.

#### 4.1 The direct impact of the technology on the care processes

Ideally the technological solutions in the LTC milieu should cope in a balanced way with all the organisational, clinical, administrative and social issues, first of all to help citizens and their informal carers to address the health and wellness challenges of our Ageing Society, increasing the opportunities for self-management and reducing the burden on informal carers.

The mitigation of the impairments and of their effects on the care recipient and the increased possibility for the informal carers to satisfy a reduced demand will on one side ask for less formal services and on the other side will enable both of them to continue to contribute to the economies of their communities.

The technologies could also enable greater efficiencies in the development, commissioning and delivery of direct care services, at home or in care facilities, by the formal carers.

Therefore among the direct influences on the actual LTC processes are the following modalities:

- to alleviate the dependency of the individuals, by an appropriate restoring or replacing of the defective functions or by adapting their environment;
- to improve the safety and to timely detect potential problems, e.g. by the surveillance on the environment and by reducing the effects due to misbehaviour of the care recipients and of the informal carers;
- to support the individuals and the informal carers on collateral activities, e.g. administrative procedures, education about lifestyles; and
- to orchestrate the collaboration among the formal carers and with the recipient of care and the informal carers.

#### 4.2 The indirect influence of the technology on the LTC context

It is also important to consider the different forms of indirect impact, which may be categorised in three streams:

- the activities dealing with managerial issues, e.g. to support the managers in the set-up of the organisational model and in the promotion of the quality and the appropriateness of the system;
- the activities to partially prevent or delay the LTC, e.g. to assist in the care of the chronic conditions and their consequences, in order to slow down the evolution of the diseases and mitigate their (permanent) effects on the daily life, including on the impairments related to ADL and IADL; and
- the modalities focusing on technological issues themselves, e.g.
  - to intervene in the production of the technologies, to obtain more effective or cheaper devices, e.g. new materials, new production processes, new designs;

- to intervene in the adoption of the technologies, e.g. by portals with a description of the available devices or services, by showrooms to assist the consumer in the selection of the appropriate device; and
- to improve the effectiveness of the ICT solutions, e.g. to produce and maintain a body of coding schemes and structured knowledge (info-structure) in a format suitable for computer processing, to assure the semantic interoperability.

Accordingly, each kind of technological solution will have a different strategic and practical impact, depending also on the regulatory and organisational context.

### ***The context for the technologies in the LTC field***

The industry that could be involved in the LTC environment is still underdeveloped, mainly as a result of the inability of the demand-side to systematically cope with coordination and adequate investments on the core business of health and social care, i.e. on the kernel of the care processes. We shall see in this deliverable that several valid solutions already exist and recently suitable smart equipment are being made available, to better cope with the complexity and the particular context of homecare needs.

However, often the awareness of the policy-makers is not adequate. We argue that:

While most of the low-tech (and low-cost) equipment could be spontaneously adopted by the individuals, as consumers, the high-tech solutions should be supported by the providers, as a systemic component of the care provision.

In addition, differently from other technologies, most health and social professionals still don't perceive the technological solutions in LTC as useful and effective for their daily work and to improve citizens' health; in other situations, e.g. for innovative diagnostic equipment, they instead exert the necessary pressure on the managers and on the policy-makers for a rapid adoption and are willing to accept the related organisational changes.

Evidence was acquired (see section 6.3) that the collaboration among health professionals and with the citizens themselves, based on innovative organisational models (integrated disease management, chronic care model) is able to slow down the evolution of the diseases, to diminish complications and sequelae, to improve the quality of life, to reduce the number of hospital admissions (Tak et al., 2010): in other words, it positively impacts both on the satisfaction of the patients and on the sustainability of the system.

Nevertheless, the practical deployment of those models is hindered by the dispersion of the professionals and of the citizens in the territory, by the fragmentation of the care activities, by the insufficient communication among the professionals and with the care recipient, by the inadequacy in the capture of clinical data.

Moreover, health professionals encounter a difficulty in the transfer of know-how from the theoretical education to the daily practice. As a consequence, the quality of care cannot be optimal without a crucial support by ICT solutions and home equipment for surveillance and measurements.

## **5. The potential direct role of the technologies in LTC provision**

The integrated deployment of suitable equipment and ICT solutions could be an enabling component for the diffusion of the new care models. For example, a document written in the context of the "Care Services Improvement Partnership" by the UK Department of Health emphasises the potential role of telecare and telehealth for remote monitoring at home for the 15 million people living with a long-term condition, remarking that *'to be successful this needs to be part of the local health and social care pathway for managing Long-Term Conditions'*. (Brownsell, 2008)

The **systemic usage** of equipment and ICT means that they are adopted by the management as a crucial component within a specifically planned, purposive reallocation of resources, role, and responsibility, to deploy an innovative care model.

The technology could contribute to produce a significant improvement on quality and appropriateness of care; reduce the dependency of the care recipient, and as a consequence reduce the burden on informal carers (which could for example recover more time for their job and their normal activities in the community); alleviate the consequences of the impairments; avoid the risks linked to mild dementia or frailness by appropriate protections and sensors and activate prompt interventions in case of accidents.

In particular, ICT could provide various innovative services; e.g.

- manage the daily agenda and provide reminders, especially about the self-management activities (e.g. about medicines or data collection);
- improve the capture of the most relevant data for each condition (including surveillance and physiological measurements), with an immediate check on their quality and relations to previously available data and knowledge, and, if needed, generate alerts sent to the proper person;
- offer the possibility to perform remote administrative procedures and exchange structured organisational and care data among all the actors that are involved around the same care recipient;
- facilitate the data analysis and the comparison among subjects of care for the self-audit of the professionals and for the optimal management of the care plans;
- produce the proper routine data needed to generate timely governance indicators; and
- enable tailored educational programs – including simple instructions or explanations based also on case-specific data – for all the professional and non-professional actors.

The proper adoption of specific technological solutions could make the difference, without replacing the need for a virtual or physical presence of formal and informal carers. For example, the New England Healthcare Institute estimates that 13% of the total healthcare expenditures could be avoided if medication adherence were improved (NEHI, 2009); the various technological solutions that are available to improve the use of medications (Center for Technology and Aging, 2009) could complement the support by the carers.

Regulating their own medicines can be a challenge for some people, especially those who are older and suffer from long-term conditions. Their inability to take medicines correctly can be a major reason why they end up moving to a nursing home: as many as 23% of older people move into a nursing home because they cannot manage their medicines (Department of Health, 2006a or b?). Many other people with a Long-Term Condition are admitted to hospital, often as emergency cases, because they are not taking medicines correctly.

In other words, this example tells how a success on the appropriate management of medicines, enabled by a technological support, could allow a reduction of the resources currently assigned to nursing homes and hospitals, i.e. could gradually bring to a significant reallocation of resources towards new services in primary care and social care.

## 5.1 The combined effect of smart equipment and ICT

The widespread adoption of ICT – together with an appropriate remote usage of home-based equipment (often named as “telehealth” or specifically “tele-home care”) – offers a range of opportunities to the evolution of Long-Term Care. Some potential effects of the combined deployment of the equipment and of the ICT applications were identified by [Clifford 2010] as follows.

The care recipient could appreciate an increased access to health care, an increase in health knowledge/ability for self-care, a faster or more accurate assessment and treatment, a reduction of waiting or consultation time, or can perform an increased medication adherence. He will need less travel (and thus less expenditures and less time lost).

The provider could obtain a reduced length of stay, avoid hospitalisations, readmissions, accesses to the emergency department, care recipient transportation.

Furthermore, among the various kinds of benefits, let us focus on the following ones:

- Better care: early detection of events, a more regular follow-up, a reduction of complications. The involved professionals can consult anytime the electronic record and improving the decision making process, with the final result of more efficient and appropriate services, closer to recipient's needs.
- Faster and easier accessibility to service for the citizen and more frequent interactions with the formal carers. This means that more care recipients can be cared staying at home, reducing the hospitalisation rate or the admission to nursing facilities.
- Hospital inpatients with significant consequences of chronic conditions are leaving hospital sooner (reduced average length stay in hospital), because it guaranteed the continuum monitoring at home. Treating care recipients at home is less expensive than treating them in the hospital, many recipients prefer to stay in their homes as long as possible before moving into a higher level of healthcare service.

The costs savings linked to Tele-home care may be due to the combination of several effects: reducing unnecessary visits to emergency room, reducing unnecessary visits to physician's office and hospitals and improving symptoms management by providing education of the care recipients. The practitioner has also an opportunity for more timely intervention improving responsiveness of care recipients and higher frequency of visits by nurse.

### **5.1.1 The key rules for a citizen-centred care system**

The core of the advanced citizen-centred care approach resides in the development of new ICT system and more specifically in citizen-centred information system linked to the appropriate home equipment [Tak et al, 2010].

The ICT systems can be grouped under the unique term of eHealth, which refers to all the form of care delivered with the support of ICT ranging from clinical, social, administrative and education/research to direct services offered by professional, non professional, business and consumers themselves [Jossei-Bass 2002]. This leads to the identification of "eHealth" as an umbrella term which can encompass a range of services or systems; it covers all health strategies: prevention, treatment, rehabilitation and, in the broadest sense, also social care.

The combination of ICT and home-based equipment is expected to contribute to the development of new ways of delivering healthcare services and it will impact on the organisation and structure of the healthcare delivery system revolutionising the care sector. Moreover the development in the wireless and mobile markets has taken care from local areas into recipient's home and more recently everywhere the recipient might be.

It does not only imply the penetration of the technology progress per se, but also a new framework to design care models for improving citizens' health, enabled by the technology.

Spil [2006] emphasised the customer view-point when he defines eHealth as "a consumer centred model of healthcare where stakeholders collaborate, utilising ICT and internet technologies to manage health delivery".



According to Ulieru [2008], citizen-centred information system must involve: care customised to recipient's needs, care controlled by recipients, unrestricted access by recipients to their records, sharing of knowledge freely between recipients and formal carers.

A Technology-Assisted LTC environment includes a broad range of information technologies and equipment that enable care to be delivered to care recipients at locations other than the hospital, the nursing home or the physician's office. Adopting the technology out of the traditional hospital setting implies that care recipient need to be able to use the system alone with a reduced or absent level of professional support.

A wide array of applications is included and should be implemented by health providers to ensure more efficient and appropriate health delivery system, e.g. personal health record, remote blood pressure monitoring and online second opinion. The key challenge for ICT professionals is to design and implement applications and systems that are driven not by technology but by user needs accommodating the epidemiological trends [Westbrook 2007].

Citizen-centred eHealth system is also seen as a powerful tool for disease management because the web offers a widely available, low cost and flexible means of communications between care recipients and healthcare professionals and thus enables treatment programmes tailored to the individual and dynamically regulated using the data entered by the care recipient for self-management or monitoring, e.g. for asthma, dementia, diabetes and chronic heart failure.

The regular monitoring of patients affected by chronic disease requires the data acquisition (from the patient, the informal carers, with a possible usage of appropriate equipment) very close to the daily life of the recipient, adapted to the user in order to capture the expressed and unexpressed needs.

The equipment not only allows long-term, continuous monitoring of physiologic information (such as: heart rate, blood pressure, blood oxygen saturation), but can also provide more realistic indication of the care recipient's health status. Medical Devices are applied to the body of each single care recipient, tracking the health status on regular basis, understanding the evolution of the long-term conditions more properly; non-invasive "wearable" sensor or "smart" sensor [Lymberis 2004], are based on the incorporation of sensors into watches, item of clothing and eyeglasses.

In addition to monitoring devices, videoconferencing products are used in Tele-home care to enable the remote interaction of care recipients and informal carers with the formal carers.

The specific technological solutions and devices for diabetes, obesity and dementia have been reported in the companion deliverable of Work Package 4 of this project.

The technologies, typically used in Tele-monitoring systems are characterised by some common elements:

- they may be miniaturised, physically embedded in wearable device granting the maximum care recipient mobility, often connected to a mobile (smart)phone;
- they enable high integration and low power consumption (i.e. they can be battery-operated);
- the cost effective realisation allows the product to be manufactured in mass numbers;
- they may have an increasingly high usability thanks to intuitive user-interfaces, increasingly adapt to elderly people with no experience with ICT and internet.

One feature is the opportunity to enforce an individualised style of care provision versus a one-size-fits-all approach, tailoring the care (and the technological support) to individual needs.

A tele-health system may properly capture the health need of a specific target population. The non invasive and easy to use application in order to monitor the daily life symptoms and vital signs, enables the clinical staff (e.g. a GP or cardiologist or a nurse) to take more "personalised" decision, thanks to the consultation of a shared personal record with data generated by a colleague, or by the care recipient and the informal carers, perhaps through a home equipment.

### 5.1.2 *The effect of technologies on ADL and IADL*

The technologies for ADL and IADL include the usage of equipment that produce a direct effect on the reduced function, or any equipment that takes effect on the environment (e.g. domotics), either for surveillance of relevant parameters and management of alerts or to facilitate the carrying out of the daily activities. The specific solutions suitable within each specific case study (obesity, diabetes and dementia) will be considered in Deliverable 2 of WP4.

The technology that is appropriate at home is also usable in the nursing homes and other LTC facilities, but not vice versa: more sophisticated (and expensive) technology requires a critical mass of users. Analogously, accessible homes and domotics are suitable for specifically designed new buildings, and more difficult to be installed a posteriori in older buildings.

The technologies to support most of the Katz basic ADL functions (i.e. bathing, dressing, toileting, transferring, continence and feeding) are very peculiar, i.e. each of them produces a very circumscribed impact. The future evolution of the direct effects of technologies on the ADL will be probably modest. In fact, the basic ADL appear as *not suitable for further significant direct advancements about the technologies*: dramatic progresses were already made e.g. on stair elevators, on diapers for incontinence. Human assistance will remain a must to support most severely impaired ADL activities.

The evolution of the direct effects on the IADL (as defined by Lawton and Brody, i.e. use telephone, shopping, food preparation, housekeeping, laundry, transportation, medications, finance handling) will be perhaps relatively important, especially if combined with indirect changes in the modalities to perform the same activities. For example, the usual telephone appliance can be replaced by a display for video-communication with a remote care manager or with a specific relative (a modern version of this device is just appearing on the market, produced by Intel and other big companies).

Also about IADL there were significant achievements, e.g. on (industrial) food preparation and storage, special telephone sets, remote shopping. IADL activities are more suitable for alternate ways to be performed and thus to be assisted by technology. Other daily activities, perhaps equally important, could be supported by technology, e.g. social relations or hobbies.

In addition to the earmarked appliances for ADL/IADL and to information technology, a new generation of equipment is appearing, which can be placed at home or in LTC facilities, which are able to perform measurements, generate alarms, capture videos. This equipment can be remotely controlled and can send data to remote places for appropriate interpretation by skilled people, allowing more people to stay safely at home or in the LTC facilities instead than in hospitals.

Several pieces of equipment are purpose-specific,  
i.e. each type of equipment is conceived for a specific defective function;  
therefore it produces a very circumscribed impact  
and a general theory is not possible.

### 5.1.3 *Safe and ubiquitous access to information*

The future social and health record, i.e. the electronic storage of data, should be highly secure and accessible by the authorised individuals across all the geographical areas; the access to specific subsets of data will be typically restricted to the author, the care recipient and – with limitations according to precise regulations – to the other formal carers that have a specific need to consult them. With suitable authorisations, also the informal carers can be enabled to interact with the record.

In the ideal case, in a Home Tele-care system the monitoring of vital signs by wireless Medical Devices may be integrated with expert decision support system (DSS), which may support formal and

informal carers about the decision-making activities in terms of drug administration, possible treatments adjustment.

Anonymised data can be used by the management for governance purposes.

## 5.2 Opportunities for the technological solutions in LTC

In the following table we consider an interim classification of care tasks with examples of specific activities to be performed, which could be assisted by some technological solutions.

For each activity, we worked out the role that could be taken by the equipment and/or by ICT to assist the care process, and the role for the formal and informal carers. The support may be given to the professionals (e.g. to facilitate the care provision for a nurse), or to the informal carers, or the technology may be directly operating on the care recipient (e.g. special bed, prosthesis). Note that the table considers the care tasks and the activities performed (which can be carried out by various mechanisms) rather than the goal to be achieved (e.g. to support, prevent, alleviate; see Section 0).

*Table 3. Care tasks, activities, technological solutions and actors*

type of care task	examples of activities	role for technology	role for care recipients and informal carers
information capture and record	measuring, observing	equipment for surveillance and measurements telemedicine	activate tele-monitoring record measures and observations
information retrieve and display	charting, selecting, retrieving data	EHR	self-assessment
decision making	setting objectives, interpreting data	tele-consultation	notify unexpected events
procedural / operational intervention	feeding, administering medicinal products, rehabilitation therapy, bathing / washing	support devices, reminders	assisted tasks
administrative procedures	booking, seeking consent	e-booking, e-prescribing	simplified procedures
transfer of knowledge – know how	teaching, training, informing, counselling	e-learning tele-support instructions through internet (portals )	receive information

### 5.2.1 Examples of care tasks that may be assisted by technology

In Table 4 below we present a set of more detailed, non-exhaustive examples of care tasks in different contexts that could benefit from the adoption of technological solutions for an optimal management of the Long-Term Care activities.

*Table 4. Examples of care tasks in various LTC contexts*

context	examples of care tasks
secretarial services	to maintain a register of citizens enrolled in a care program
	to recall the citizen (up to a few times per year) to solicit for a new check of significant parameters
	to organise the logistics of the provision of social services to frail persons
	to simplify the administrative burden
multidisciplinary care team	to perform a multidimensional evaluation of the care recipient's situation
	to design and deploy a shared plan (goal, role, responsibility and activities for each actor, including citizen and informal carers)
healthcare professionals	to order periodic measurements or observations of sentinel parameters according to specific care pathways, a few times per year, for the early discovery of increasing needs
	to perform a mix of complex activities, with interaction among therapies, and difficult planning over a long temporal span (decisions and responsibilities of citizen and informal carers are limited: clinical care is mostly delegated to professionals)
health and social care professionals	to coach /educate citizen and informal carers on the specific health issues, on the patterns of their evolution, on the optimal behaviour and life style to slow the evolution, on the recognition of the risks and the changes in the situation to be notified to the clinicians
	to reduce the burden on the informal carers about the daily activities with the beneficiary
care recipient, informal carers, home nurses	to allow the recipient of LTC to reach the maximum level of adaptation to the daily activities (including, but not limited to, ADL and IADL) and social context, compatible with the residual functionalities
	to perform a periodic assessment (perhaps daily) of relevant parameters, also by home equipment that may be directly connected to the network and to a contact centre
	to perform simple judgments on fine tuning of the therapy according to predefined parameters

### 5.2.2 Examples of requirements about technological solutions

The following table provides a set of non-exhaustive examples of requirements, which could be satisfied by the adoption of technological solutions, for an optimal management of the above tasks in the various contexts of Long-Term Care.

In this table we focus mainly on the systemic issues, i.e. we are not considering the large amount of very specific low-tech tools and equipment that are adopted by the individuals and by the informal carers in their immediate context to cope with particular impairments.

*Table 5. Examples of requirements related to information management in various contexts*

*Care recipient and informal carers*

<p>To manage home equipment and their connection to the network</p> <ul style="list-style-type: none"> <li>• passive user – when generic domestic equipment is able to send data to a remote centre, without a local intervention (e.g. fixed webcam, sensors – detectors of presence, movement, pressure, water, gas, ...); permanent measurements (on the care recipient in bed, wearable devices);</li> <li>• reactive user – the user performs equipment setting and measurement, guided step by step by the equipment (perhaps after training and with printed / web based instructions);</li> <li>• user interactively guided by a professional – the user performs the procedure, interactively guided by a remote professional (e.g. video consultation on skin lesions);</li> <li>• proactive user – when the procedure is actively managed by the user, with limited decisional responsibilities (perhaps after a significant training, or using interactive instructions – help line).</li> </ul>
To deploy advanced modalities of communication with the professionals (tele-presence, email, filling in web based forms, etc.);
To support to the informal carers in performing complex procedures, also with permanently operating home equipment
To store systematic self-made observations and a log of the performed activities (e.g. measurements), e.g. in a web-based Personal Health Record
To share information and experiences within a community of citizens with similar health issues
To access to simplified administrative services (download / fill in of forms for requests, reimbursements, etc)
To provide web sites with authoritative clinical knowledge and the description of optimal behaviour with training exercises (and perhaps related e-learning services);

*Health care professional (GP, geriatrician, care manager, home nurse)*

To register the citizen on a suitable list (e.g. a local register), with a synthetic description of the health issue and of a few parameters, to facilitate the periodic recall of the citizen and the prescription of periodic tests or visits
To record a re-assessment of the care recipient's situation that requires changes in the ongoing care plan
To notify (suspect) changes in the care recipient's situation
To record and update the multi-disciplinary evaluation of the care recipient's situation (with selective access)
To record and update the shared plan (with selective access)
To manage a common agenda of planned care activities (with selective access)
To manage rescheduling of activities caused by unplanned events
To capture data and record impressions, observations, interpretations, decisions, activities
To timely communicate - as appropriate - to other professionals (notification of contacts and other relevant events, assessments or other clinical data)
To perform decisions (access to up-to-date specialised knowledge, alarms on drug interactions, tele-consultations);
To send a generic referral to an agency or an earmarked referral to a specific professional (with feedback on the activities performed and the related documentation)
To delegate a task to an agency or to a specific professional (with feedback on the activities performed and the related documentation)

*Social care professionals*

To assist all the actors in their coordination
To support the logistics of provision of goods and services
To document the performed activities

#### *Contact / service centre*

To manage the contacts with the care recipient and the informal carers
To provide simple advice to the care recipient as a basic triage
To monitor the data from the care recipient or from home equipment
To issue potential alarms to appropriate specialists

#### *Health and social care managers*

To capture data directly from the stable operative processes (the stability of the care tasks and their compliance to evidence-based clinical pathways allow to characterise well-defined clinical data sets)
To calculate and interpret suitable indicators, as a tool to control the trend of the care phenomena
To capture data directly from the evolving operative processes (a systematic capture of data is very difficult, because the clinical situations are too unique and not comparable; often there is a lack of a reference evidence-based clinical pathways to be taken as guidance. The calculation of indicators is often not effective, because they are not able to assess the appropriateness of the decisions with a statistical significance.

### **5.3 The technology for the engagement of the care recipient**

The most promising applications of the technology to the LTC needs are Telecare and Telehealth; the two terms are in practice interchangeable: one puts more emphasis on the process of care provision, the other on the outcome on the individual. For the UK Department of Health “*Telecare is as much about the philosophy of dignity and independence as it is about equipment and services*”.

*“Equipment is provided to support the users in their home and tailored to meet their needs. It can be as simple as the basic community alarm service, able to respond in an emergency and provide a regular contact by telephone. Or alternatively another form of Telecare, often known as Telehealth, is designed to complement health care by monitoring vital signs, such as blood pressure, and by transmitting the data to a response centre or to a clinician’s computer where it is monitored against parameters set by the clinician”* [Brownsell, 2008].

Both the above modalities of service provision combine two distinct technological components: the equipment to generate the information and the ICT to transmit and process the information. To be successful this approach needs to be part of the local health and social care evolutionary pathway for managing Long-Term Conditions.

#### **5.3.1 An opportunity to stimulate the engagement of the care recipient**

The active participation and accountability of the care recipient in managing his or her own health and well-being may be increased by the ICT adoption. Generally speaking, nowadays, individuals are more aware and informed due to the pervasiveness of health information available through the Internet, television, magazines, and newspapers.

By facilitating the data acquisition from the home equipment and by flow of information between formal carers and a remote care recipient, the technological solutions have as result that individuals are not only informed but even more conscious of their actual health status. Several non expensive equipment is increasingly available, that are often handheld, wearable, easy to use, like: blood pressure cuffs, spirometer, pulse oxymeter and ECG. Their friendly interface may allow to access complex Decision Support System (DSS) installed for example in a smart phone or home PC.

A stronger care recipient involvement is required in case of automated self-management monitoring than in the case of telephone monitoring. In the first case patients with chronic disease are personally responsible for their own day-to-day care, perhaps with the assistance of an informal carer. Each day they insert by themselves the data in their own home PC or by earmarked communication devices, following the verbal instructions from the monitor e.g. to weight themselves and using the equipment to record their blood pressure and heart rate. In a typical case of telephone based-monitoring the involvement of care recipients in terms of self-management is reduced, in fact they simply answer to questions asked by a nurse who will insert the data in the decision support software, which set priorities for care recipients' education.

### **5.3.2 The role of technologies to support to self-management**

The most important sector in the next years will perhaps be the support to self-management, in a broad sense, i.e. all the technologies that could assist either an individual or the respective informal carers in the mitigation of the effects of the weakened health conditions. In this way there is less need of formal and informal carers, and an effective engagement of the individual may delay or avoid the consequences of the chronic conditions, with a positive impact on the LTC services.

As defined in England by the NHS, the term 'self care' includes both self-care and self-management [Department of Health UK, 2006], and namely: staying fit and healthy, both physically and mentally; taking action to prevent illness and accidents; the better use of medicines; treatment of minor ailments and better care of Long-Term Conditions.

The term 'self-management' has been defined by [Martyn, 2002] as: *“whatever we do to make the most of our lives by coping with our difficulties and making the most of what we have. Applied specifically to people with a schizophrenia diagnosis it includes how we manage or minimise the ways the condition limits our lives as well as what we do to feel happy and fulfilled to make the most of our lives despite the condition.”*

Demand for self-management tools — as technologies used by consumers to manage the health issues outside formal medical institutions — is gaining momentum. The interest springs from a variety of converging influences: new ideas about clinical care, universal concern about costs, political interest in stimulating competition among providers, shifting consumer habits, and technological innovation.

The possible roles of the care recipients towards the technologies may be described as follows [Barrett 2006] (see also

Figure 2):

- subordinate roles, leaving modest discretion within a strong supervisory context; they imply greater precision, fewer errors, and less stress.
- structured roles, involving more active but limited care recipient participation.
- collaborative roles, using their knowledge and making decisions jointly with clinicians.
- autonomous roles, coping with health matters without major participation by formal carers.

Figure 2. A typology on technologies for self-management

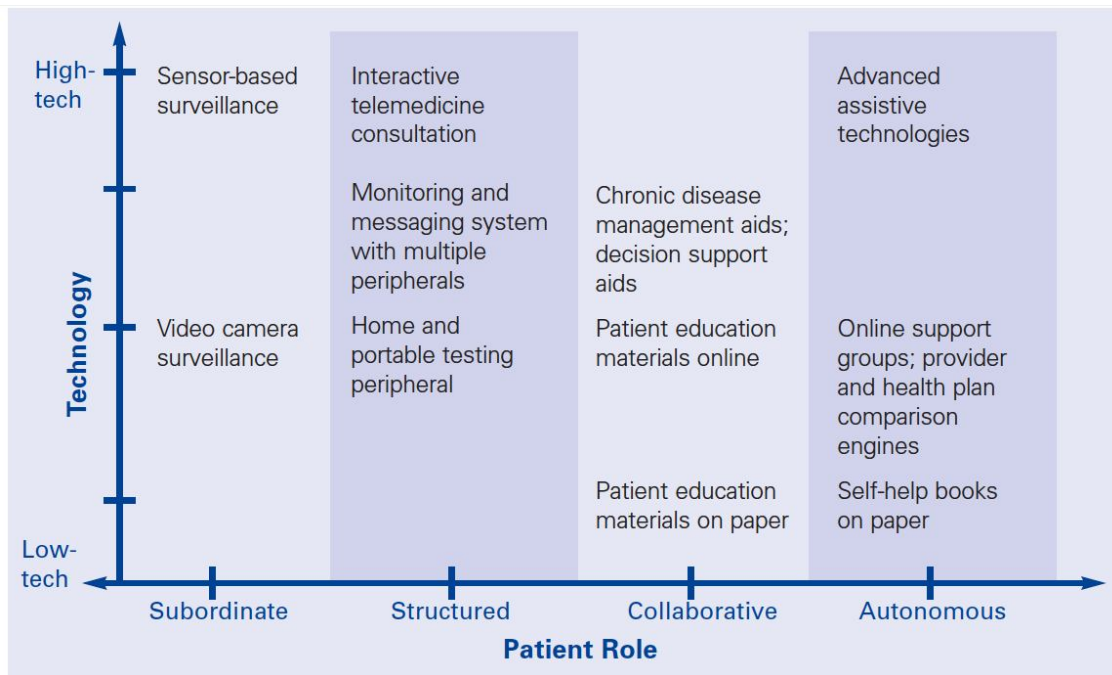

Source: Barrett (2006).

It should be noted that this typology is built from a consumer point of view and not from a systemic point of view, as it is based on the role carried on by the care recipient (perhaps with the contribution by the informal carers). In other words, the above typology considers the care recipient/beneficiary as a consumer and limits the analysis to the direct environment of the care recipient.

A complementary point of view should consider that, if the care recipient adopts (or is offered) a technological solution that is embedded into his/her ecosystem, then that technological solution cannot be considered in isolation, but it should be perceived as a component of the systemic LTC process as a whole, looking also at the organisational issues on the side of the providers.

In fact, a complete model should consider four entities:  
 the care recipient, the informal carer,  
 the technological support (the equipment or the information system)  
 and the formal carers (as a part of the care system).

Therefore, from an organisational point of view, it is possible to conceive a different typology based on the role of the formal carers, with the main goal of allocating the proper resources to optimise the LTC processes as a whole, considering also the availability and the skills of the informal carers.

The new typology could be based for example on the skills that the providers should be made available, the burden on the formal carers and/or on the informal carer, the suitability for the particular



state of the beneficiary and the need for the mediation of an informal carer, the triage activities/data processing that should be performed by the formal carers, the reallocation of tasks to be performed by clinicians, social care professionals, informal carers, care manager, operator of the contact centre.

This additional classification should focus on the care services that could be offered by the providers to support the different modalities of self-management (or management assisted by the informal carers). In this case the technological solution should be perceived as a component of a comprehensive care service, which is “natively” included in the individual plan of care; its adoption should be foreseen by the authorities and by the insurances in the regulations and in the reimbursement policies.

Yet another perspective could be from the point of view of the informal carers, looking at the technologies that either support them to undertake some more complex tasks that are currently performed by the formal carers, either to reduce their involvement in some tasks that can be taken on directly by the care recipient or performed by a device.

### 5.3.3 *The engagement of the care recipient*

A care recipient is really empowered if he is educated to manage correctly his condition and if he is able to have a proactive role about his health.

Several recent ICT solutions are able to provide support to the care recipient and the informal carers in order to assist them in changing lifestyle and health habits, to increase the compliance with the therapies, to improve the appropriate access to care services, to enable a more aware choice among candidate procedures, services and facilities.

Technology can be the key element to disseminate the new models of care, also through the widespread adoption of new job profiles, as the ‘care manager’ and through the support to the proactive involvement of the care recipient and of the informal carers, with the increasing support to self-care, as an important component of the overall process of innovation of the LTC provision.

Moreover, “*The beneficial impact of different types of self care support will be best achieved if the self care support resource is integrated and also includes self care skills training for health and social care professionals*” [Department of Health UK, 2007].

Relatively simple support in the self-care can be given to the care recipient and to the informal carers through reminders and recording about the appropriate drugs administration and about the measurements by smart home devices. In fact, modern devices are able to perform accurate delivery of drugs and reliable measurements, at home or in nursing homes, without the intervention of skilled professionals.

Modern devices are available, able to perform accurate delivery and measurements of drugs, at home or in nursing homes, without the intervention of skilled professionals. For example there is a medication dispenser enabling the carer to be absent when the care recipient is due to take his medication; it automatically sends a reminder and dispenses the appropriate dosage only.

More in general, the support to self-care can be provided by several modalities, e.g., by a better management of the care plans or by the processing of information, or by computer-assisted education and training, or through appropriate devices (see Table 6 below).

*Table 6. Examples of application of technologies to self-care support*

<b>Self-care information</b>	<b>Technologies and self monitoring devices</b>
<ul style="list-style-type: none"> <li>• advice on self care</li> <li>• audio visual aids</li> <li>• behavioural instruction</li> <li>• booklets on self care</li> <li>• counselling</li> <li>• exercise handbooks</li> </ul>	<ul style="list-style-type: none"> <li>• biofeedback</li> <li>• blood glucose monitoring</li> <li>• bright light therapy</li> <li>• computerised provider prompt</li> <li>• computer assisted treatment planner</li> <li>• computerised diet assessment</li> </ul>

- information prescription
- interactive feedback
- lifestyle information
- patient care records
- telephone advice
- written materials
- workbook for self care

- glucometer data transmission
- hearing aids
- home monitoring
- network data transmission
- self monitoring of BP
- self monitoring of glucose
- self monitoring of medicine

*Source:* adapted from Department of Health UK 2007.

#### 5.4 The support to collaboration in LTC

Differently from the hospital-centred care, when dealing with LTC it is pretty difficult to draw specific standardised patterns about the organisation of care provision, also for the important but heterogeneous contribution of proactive care recipients and informal carers.

Additionally, also the general guidelines (e.g. delivered by international Professional Societies) – when they exist – suffer from the difficulties of an adaptation to the local implementation in the peculiar context of different care systems.

The clear definition of the tasks and of their objectives, i.e. the definition of the mutual roles and responsibilities among the actors, is a prerequisite for the optimal management of the care process as a whole and – more important here – for the application of ICT.

In turn, any difficulty in the harmonisation of tasks influences the deployment of the advanced care models and in particular of the usage of the technology to improve the continuity of care, the collaboration among all the actors and thus the effectiveness of the communication.

No technological solution can replace the willingness to cooperate and communicate among the actors, and thus the proper use of the equipment for measurements, surveillance, alerts and of the complementary information management.

In dealing with such problems we will focus two aspects of the Long-Term Care:

- The task interdependence, as defined by Thompson [1967] and revised by Van de Ven et al. [1976], that governs the relationships among different actors while delivering the Long-Term Care services;
- The relationship between the formal carers on one side and the care recipient with the informal carers on the other side, based both on interaction (e.g. communication, information retrieval and exchange) and cognitive elements (e.g. trust, loyalty)

While the “trust” could be referred to the mere and personal relationship between the care recipient and the formal carer, the “loyalty” implies a long-term commitment toward the organisation(s) that provides the care. On the other hand, loyalty can be promoted by the organisation(s) by delivering memorable customer experiences, which in LTC may include the delivery of many services across a wide spectrum of events of interaction.

Considering a general organisational setting, Thompson [1967] defined interdependence as the need for achieving concerted action. Van de Ven et al. [1976] further clarified this as the extent to which personnel in an organisational unit are dependent upon one another to perform their individual jobs.

In the case of Technology-Assisted LTC we should consider a wider idea of a coherent “virtual team” including formal carers from different organisations and also the contribution by the care recipient and the informal carers, i.e. a unique combination of actors performing an interdependent set of tasks to comply with the peculiar needs of each care recipient.

More recently some papers [Grandori, 1997; Crowston, 1997] has extended the concept of interdependence between two (or more) tasks where the performance and outcome of one task are affected by, or need interaction with, the performance and outcome of the other task.

The typology of task interdependence introduced by Thompson [1967] distinguished three types of interdependence: pooled, sequential, and reciprocal (Figure 3). Lately Van de Ven et al. [1976] added a fourth type of interdependence – team or intense interdependence.

The following figure, proposed by Kumar et al. [2008] as an adaptation from Van de Ven et al. [1976], provides models of these interdependencies: rectangles represent work sites or locations, and circles the actors within the location.

Figure 3. A taxonomy of interdependence

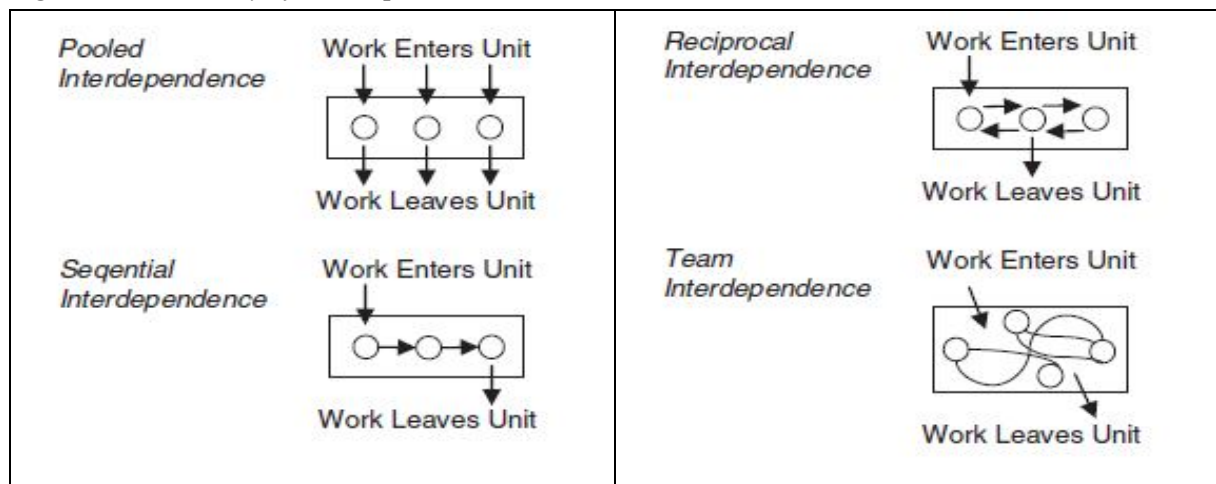

Sources: Kumar et al. (2008) elaborating on Thompson (1967) and Van de Ven et al. (1976).

Since the classic typology does not distinguish between co-located and distributed work, Kumar et al. depicted all actors in a work unit collocated at the same work site; we can consider a broader interpretation by including the remote collaborations inside the virtual team assisted by ICT, which reduces the spatial barriers.

#### 5.4.1 Pooled interdependence of tasks

First, *pooled interdependence* is defined as the situation in which “parts contribute independently to and are supported by a whole, and no workflows exist between actors” [Van de Ven et al., 1976]. Grandori [1997] defines pooled interdependences also as the one that arises from sharing a pool of resources. Individual efforts and contributions of each work unit are completely independent of other work units, and exist and operate by themselves, on their own. Thus, as shown in Figure 3 for pooled interdependence, the total production function is cleanly separable into discrete, completely independent, but similar sub-tasks performed by different actors.

The only connection between sub-tasks is the periodic (e.g., annual or quarterly) linear addition or pooling of their outcomes at the system level. However, each actor or work unit performs its task independently of each other, and need not be aware of other actors or be concerned about subsequent pooling.

Periodically the actor's individual contributions are pooled at the organisation level, such as overall sales or productivity/performance. However, the outcomes of each work unit (e.g. physicians or health care departments) have existence and value independent of outcomes of other work units.

In the healthcare environment, pooled interdependence might exist between prevention or primary care departments and intensive care units while they both address their services to the same population target (e.g. patients with diabetes). More in general, this situation is common in jurisdictions where either the disease management principles and the chronic care model still are not applied or the health care providers are separated from the social care providers; only loose relations could spontaneously exist among the actors.

In the LTC context it is difficult to find situations that are by nature completely independent, although a similar scenario may be partially applied when considering the care for a chronic disease and the social care on the same individual: the care processes are reasonably separated, even if a certain degree of information sharing is appropriate.

#### **5.4.2 Sequential interdependence of tasks**

Second, with *sequential interdependence*, individual work unit activity is directly connected in a linear stream [Van de Ven et al., 1976]. Thus in Figure 3 the output of work unit A's (e.g., diagnosis) becomes an input to a different work unit B (e.g. treatment). Each work unit adds value incrementally to the work in a serial manner.

The undesired phenomenon of “throwing outputs over the wall” is quite common in organisation whereas bureaucracy and lack of coordination affect the overall organisation. In such cases, output are “thrown over the wall” to the parties performing the next task, without any consideration of whether the other party receives it or not, or whether the outputs themselves are complaint with the expected requirements or correctly understood.

In the LTC environment we could have this kind of scenarios when the care recipient “belongs” in different periods to different organisations, as the hospital, the nursing home or the primary care services. It is to the care recipient and the family the burden to collate the tasks performed by the different actors. In this case a suitable ICT support could avoid the phenomenon and induce some transmission of responsibilities and information among the points of care.

#### **5.4.3 Reciprocal interdependence of tasks**

Third, *reciprocal interdependence* refers to situations in which the outputs of one unit become inputs for the other unit and vice versa [Thompson, 1967], and work flows back and forth between the two work units over a period of time [Van de Ven et al., 1976].

An example is the diagnostic procedure whereas the some specific analysis is required. So the physician draw a first preliminary diagnosis, asks for some other elements (e.g. a vascular check-up) and he cannot complete the diagnosis until the results are delivered. This phenomenon occurs for all the ancillary services around the stream of the main care process; usually this kind of interactions are systematic and thus enough well defined (e.g. in terms of timing, context, mutual limitation of the responsibilities, information to be shared).

With pooled interdependence, multiple actors may perform independent tasks on different and separate work objects. In the case of sequential and reciprocal interdependence, at any given point in time only one work unit has custody, control or responsibility for the work object.

The key difference between sequential and reciprocal forms of interdependence is that while workflow in the former is unidirectional, it can go back and forth in the latter. As Thompson [1967) suggests, in case of pooled interdependence technology could create an effective interface in order to collect, catalogue and address information in the effective way for work units. In case of linear interdependence, technology could shorten the delivery time of the health care processes (e.g. by

speeding up the delivery of diagnosis or by enabling a continuous monitoring of care recipients, so that prompt interventions could take place).

In case of reciprocal interdependence, technology can only work if there is a mutual adjustment among the actors (work units) on how outcomes and inputs should be exchanged; in such a scenario the hypothesis of “throwing over the wall” is not acceptable.

In the LTC milieu it is normal to have reciprocal expectations among the tasks performed by most of the actors.

#### **5.4.4 Team interdependence of tasks**

In addition to the three main categories drawn by Thompson [1967], Van de Ven et al. [1976] introduced the “*team interdependence*” to the typology:

“Work is undertaken jointly by unit personnel who diagnose, problem-solve and collaborate in order to complete the work. In team work flow, there is no measurable temporal lapse in the flow of work between unit members, as there is in sequential and reciprocal cases; the work is acted upon jointly and simultaneously by unit personnel at the same point in time” [Van de Ven et al., 1976: 325].

Whereas with pooled interdependence the actors work simultaneously but independently, with intense team interdependence they work simultaneously and also jointly.

The ideas of the multidisciplinary “care team” was proposed, for instance, for the treatment of diabetic patients or moderate dementia. In such cases, starting from the considerations that patients spend roughly only 1% of their time interacting with health care professionals and that continuity is essential, the presence of distinguishable “solo” acts or handoffs between actors should vanish, or at least be considerably moderated.

As a matter of fact, team interdependence is qualitatively very different from pooled interdependence. As compared with pooled interdependence, team interdependence requires much higher levels of continuous inter-actor awareness, communication, information processing, mutual knowledge, trust, and mutual adjustment.

What is important for LTC, is not the parallel performance of the individual acts (which are necessarily performed in sequence by the different actors), but the interactions among the actors during the *parallel evolution* of each process of care that every actor is carrying on.

With the crucial support of ICT, each actor of a “virtual team” can be made aware about the details of each process performed by the other actors on the same care recipient (again, always including also the self-management of the care recipient and the support provided by the informal carers), up to the level required for performing correctly his/her task and according to the authorisations decided by the care recipient.

With ICT, all the actors can collaborate even if they are not in the same physical location; they can harmonise their mutual roles and share goals and data.

#### **5.4.5 The effect of technologies on service management**

The literature about the service management has repeatedly emphasised the importance of the human element that can provide that something extra for the delivery of superior service [Crosby & Stephens, 1987; Grooten 2007].

Within service industries the perceived quality of the service delivered is highly dependent upon the quality of interactions between the care staff and consumers. In fact service delivery process is an interactive process characterised by the human component. This means that when customers seek service, they are essentially seeking to establish a relationship.

The intrinsic service characteristics (e.g. intangibility and inseparability) imply a high human interaction [Berkowitz 2000]. Intangibility implies that a service is experienced and consumers

experience each step of the care delivery process. Hence, the encouragement of the provider-client relationship become increasingly important to service companies, as interaction is very often the only impression customer retain of the company.

In addition the inseparability of production from consumption implies a greater degree of interactions because all the actors, care recipient and formal carers co-operate and are involved in the production process. In the service quality evaluation the service's personnel interactions has a crucial role and according to Kadampully [1998] customer's perception of exceptional service is often associated with the personal interaction of the personnel.

For what concerns the Long-Term Care, and in particular the support to self-care at home, all the above concepts are emphasised with the only difference that we will increasingly not be able to talk of direct, face to face interaction; we should consider also the interactions that could happen by telephone, video or ICT devices.

The overcoming of geographical barriers implies a more frequent interaction: "decision making in home care should be an interactive process, involving negotiation, compromise and the recognition of reciprocal ties" [Collopy Dubler & Zuckerman, 1990].

The role of formal carers at home and in nursing homes is relationship centred; in fact it reflects a great deal of personal interactions between the care recipient and the carer as a means to enhance independent living. It is even a great example of the emotional connection and development of long-term relationship, critical to determine the effective treatment success.

For the care to be effective, the formal carer must empower care recipients and informal carers with abilities for self-care and the self-confidence to make decisions. To do this the formal carers must learn a great deal about the family's group dynamics in a short period of time and the formal carer interventions in the home will often involve the entire household and address health teaching and psychological and physical care.

The opportunities for remote communication among all the actors, and the possibility for an ubiquitous access to data, make the technological solutions specifically able to provide an additional support to the Long-Term Care processes and to effectively manage the "virtual team" made by the formal carers that belong to different organisations and by the care recipient with the informal carers.

The nature of the services may be modified by a close cooperation; each person of the virtual team will be enabled to perform additional activities related to care, which are currently performed by more skilled people:

- frail subjects of care will have the opportunity to be more autonomous – with a suitable degree of safety – on their routine activities (including IADL);
- they will require less support by the non-professional people around them (mostly informal carers);
- a number of those subjects of care will go under the threshold of LTC needs which was requiring the intervention of a formal carer, acquiring more independence;
- a number of tasks will be passed from professionals to non-professional people (including the care recipient), under the (remote) supervision of more skilled people if needed.

More in general, the effects of most defective functions (including some of the ADL and IADL) may be alleviated by specific equipment or the involved processes may be replaced by suitable alternate processes with similar objectives, assisted by appropriate technological solutions.

## **6. The indirect influence of technologies on the LTC milieu**

From the practical point of view, the technological solutions may be able to alleviate the dependency of the care recipient and reduce the burden for informal carers (relatives, friends, neighbours), by

providing a major improvement in the quality of daily life of the subject and of the informal carers, thus facilitating the move from care facilities to home.

This evolution may have an impact on the organisation of the care facilities (Section 6.1), and at the same time the increased availability of timely data in electronic format may assist the manager in a more effective control of the whole system (Section 6.2).

However, the technologies also provide an opportunity to enable very effective organisational models for the integrated management of long-term conditions. In Section 6.3 we shortly present the impressive evidence measured about the impact of the innovative care models on the healthcare system, which may be then reflected on the LTC environment.

## **6.1 Organisational issues in LTC provision**

We claim that – thanks also to an effective usage of the technology – the roles of home care and nursing-home care will change,

- by expanding the range of opportunities for home care,
- by increasing efficiency and effectiveness of institutional care,

thus increasing the choices for the care recipient, for the family, for the care system (about the amount of services / facilities to be offered and about how they can be regulated).

The new models of care for chronic conditions are likely to succeed to shift a percentage of the recipients from facilities to home, with people that will be more frail (also because they will present one or more chronic conditions and their sequelae) and will be more responsibilities for health care (managed at home, perhaps with the support of informal carers).

In addition, the better management of acute accidents (e.g. fractures, stroke) of frail people is not solving the health and social consequences, but brings more frail and dependent people back to home.

We could then envisage that the (imminent ?) widespread adoption of modern technologies will allow the deployment of relevant changes in the organisational model about the Long-Term Conditions: more elderly people with chronic conditions will be able to stay at home, without affecting the quality of the health care provided.

To stay at home (i.e. not in the institutions) of course is an opportunity for the individual, and it is becoming a must for the system. In fact, sustainability of the health and social system is becoming an issue in most countries; therefore (even without a proper evidence base about future evolution of the technology and the new organisational models) we could expect a change in the regulations to facilitate the home stay.

### **6.1.1 The systemic aspects of Technology-Assisted LTC**

Tele-health system should be designed on the basis of the citizen-centric approach: the care recipients are the only reason for care activity, so one should focus on meeting their needs.

The human component represents a key success factor and a limit at the same time. An organisation for care delivery cannot develop and operate appropriately a customer-focused service without motivated and trained employees: the human component is the driver that more than the others enable to create “extra value”.

The purposes of the care organisations are to improve care recipient’s health, as primary goal and, as follow, to increase care recipient loyalty and care recipient retention by strengthening and improving the relationship between care recipients and the organisation itself.

The main advantage of the Technology-Assisted LTC could be related to the improving the efficiency of the processes [Darkins 2000]: In many cases, customer satisfaction improves when the care organisations make small changes to the way they handle their time management, such as answering

phones quickly and courteously, installing a software program to schedule appointments more efficiently or investing in an additional physician to decrease waiting times.

In the same way the technology could be able to speed up the care decision processes, eliminating many intermediate steps, just wasting of time. This is possible by adding the possibility of remote contacts between the people at home (or in a nursing home) and the formal carers. Through ICT care recipients and informal carers at home can communicate with the General Practitioner, the specialists and the ancillary staff even if geographically and physically distant.

Another advantage may result from the improvement in efficacy and appropriateness of the decision taken. Home Tele-health solutions could enable the formal carers to a real-time access to objective information that are obtained e.g. by vital signs monitoring at home. Or they could enable information sharing with nurses, therapy clinicians and specialty physician, allowing doctors to take more appropriate and accurate therapeutic decision about when an adjustment to the care recipient's treatment is needed, how intervene in case of emergency and so on, given the easy accessibility and availability of all the necessary clinical data.

The items summarised in the following table depend on how the organisation effectively manages and strengthens the relationship among the care recipients, the informal carers and the formal carers and how it manages the attention that should be deserved to the care recipient's satisfaction.

In conclusion, the adoption of technological solutions within the LTC context could represent a good opportunity to improve the relationship between the care recipient and the formal carers, because it is potentially able to strengthen that relationship: the improvement in the personalisation and in the continuous tuning of the care plan, the more accurate and appropriate decision making process, the provision of a timely feedback and the speeding of therapeutic/business process.

*Table 7. Organisational implications of Technology-Assisted LTC*

<b>Items</b>	<b>Technology-Assisted LTC</b>
Citizen-centred approach	Anticipating their needs
Data workflow framework	Daily feelings and clinical parameters self-measured by care recipients are stored in the patient health record and managed by the formal carers, perhaps with the help of a Decision Support System.
Improvement in the appropriateness and efficacy of decision taken	Monitoring and storing the information regularly captured by the care recipients enables the formal carers to have an insight of the care recipient's health situation, to decide if and when an adjustment to the care recipient's care plan is needed.
Service Personalisation	Authorise the formal carers to access to the right information at the right time (e. g through patient health record) by collecting / monitoring the care recipient-generated data.
Speeding the therapeutic/business process	Remove delays in: 1) scheduling appointments, by enabling the additional service of the remote communication with the formal carers (faster and easier way to communicate) 2) by feeding directly the information in the (remote) care recipient record, the care recipient and/or the informal carers make it timely available to the formal carers
Feedback provision	The formal carers may give regularly a feedback to the care recipient, either by telephone or by sending an electronic update (e.g. by e-mail or within a shared record) to all the interested parties, if an adjustment to the care recipient's care plan is needed



### 6.1.2 “Structural Telehealth” as a consequence of a transformation of care processes

Furthermore, the Telehealth solutions are able to bring the specialised know-how to less skilled professionals and to the care recipient. This modality therefore enhances the role of the devices and that of Telehealth in the LTC provision, in particular in the redistribution of skills among professionals and in the optimisation of the virtual and physical presence of those professionals across facilities and at home.

Another opportunity for technological solutions, relevant for the management of chronic conditions, with an important indirect influence on LTC, is the recent attitude to Telemedicine [European Commission 2007, European Commission 2008, European Commission 2009].

Telemedicine is usually used with a very broad meaning, including also Telehealth and Telecare, and even several components of the eHealth solutions. In a more precise sense, it should refer only to the remote medical support, while Telehealth could be intended as a more broader term.

In this sense, Telehealth should be considered as one of the crucial components of the eHealth solutions to support the re-organisation of (chronic) care delivery. The design of public or private Telehealth services should be a consequence of a wider transformation of the processes of health and social care provision.

As far as chronic diseases are concerned, modern Telehealth cannot be considered as an isolated resource, but it is inevitable to consider it in the context of the other eHealth solutions deployed in a whole jurisdiction, e.g. as in the VA’s Care Coordination Home Telehealth – CCHT [The Joint Commission, 2008]. Moreover, it is important to consider the sustainability of the Telehealth solutions, as well as their appropriate usage to support the care of chronic conditions [Schug, 2008].

The basic objective of Telehealth is to move information and not the formal and informal carers and/or the care recipients. It may be characterised by four mandatory criteria:

an ongoing local process of care provision ...  
 ... with the usage of specific skills (e.g. by a professional) ...  
 ... at distance (i.e. remotely with respect to the local process) ...  
 ... by a decisive usage of the Information and Communication Technologies (ICT) and suitable local equipment, with respect to the usage of paper, (voice) telephone calls or fax.

Regarding the organisational issues, we should consider the attitude towards the Telehealth services to allow supporting the re-engineering of the care processes and the re-distribution of the mutual roles and responsibilities among the actors within a facility and across the facilities, including home.

Those Telehealth services may be considered according to a “structural” perspective, if they are fully integrated in the organisation of the provision of health and social care services (with a clear subdivision of roles /activities), i.e.:

- When they require a deep involvement of the managers (how they organise the care services; how they achieve the proper involvement of the formal carers and the citizens; how they regulate the related fees and incentives; how they manage to have a suitable infrastructure in place; how they conceive the redistribution of benefits from the adoption of effective Telehealth solutions?)
- When they involve clear, explicit organisational changes to reach the optimal redistribution of the human and technological resources in a jurisdiction, it is difficult to go back to a previous organisational pattern.

- When they are an intrinsic, essential and mandatory component of the care plans and progressively become a common practice so that will be perceived as a right for optimal care by the citizens.

According to the above considerations, we propose the following definition of “Structural Telehealth” in the context of Long-Term Conditions:

“modality of care provision using remote skills through ICT solutions, considered by managers and formal carers as an explicit component of reference pathways and individual care plans”.

Under this respect, it is remarkable the effort by a large number of industries and care organisations on the standardisation of the interfaces of home devices [Continua Health Alliance 2009].

The interoperability of personal health solutions allows for plug-and-play installation, effective data transfer and remote control; it will thus facilitate the diffusion of the ‘Remote Patient Monitoring and Treatment’ (RPMT).

The Personal Health Systems (PHS, mostly based on the integration of ICT and home devices) will become a crucial component of LTC because they foster independence, empower individuals and provide the opportunity for truly personalised health (and wellness) management [IPTS, 2009].

### **6.1.3 Assessing the contribution of the technology on the outcomes**

While it is possible to test the intrinsic efficacy of each single technological solution (as suggested for example by [Tak et al, 2010]), it is not easy to assess the specific contribution of the technology on the outcome of complex models of interventions, which involve a systemic deployment of several embedded technological solutions. It is reasonable to tell that multiple mechanisms could improve care provision, and among them is a proper application of the technological innovation.

It is also possible to suggest that the technologies, if appropriately selected, could have a significant role to improve the outcomes, both at the level of the individual and of the system. However it is intrinsically difficult to isolate the contribution given by each technological solution from the other improvements due to the different organisational model.

In addition, ICT solutions are able to be incrementally integrated and their synergy becomes far more powerful than the sum of the influences by each individual solution. To work out a forecast of the potential influence on the LTC sector by the future synergic ICT solutions together with the new home devices is practically impossible.

Several context-dependent changes in the role and the tasks of each actor will occur, and then the comparison should be between two processes, one using also the technology, and one without. If the modification is systemic, involving a whole jurisdiction, it is not possible to perform a case-control study. Comparing two different jurisdictions is also not completely appropriate, because the details in the deployment of an organisational model depend on the local context.

In addition, the technology, the organisational know-how and the costs are rapidly evolving and the conclusions of the trials could be quickly out-dated. Nevertheless, it is possible to foresee in the very near future a switch from the pioneering phase to a mature deployment of the technology-assisted innovation. In most cases the cost of the technology in itself could appear to be justified, if compared with the cost of stays in a hospital or in a nursing home, for the complications, the accidents, the non-appropriateness or the increased frailty that could be avoided.

However the final, generalised evidence-based proof of the axioms is still missing. Most reports are anecdotal, or with not sufficient demonstration of the specific benefits due to the technological side.

There is mounting evidence to suggest that tele-care can make a difference to individuals and their carers, and to the health and social care system as a whole. It can help to improve people's independence, relieve stress on informal carers and improve clinical and care outcomes.

Numerous trials of specific tele-care technologies and services are being reported from across the world [see e.g. COCIR 2010a, b]. Some focus on particular applications of tele-care technology, for example aimed at people with hypertension or diabetes. Others report on more generalised applications for older people such as home safety and security. There is also a growing use of information and communication technology to provide advice, guidance and support for people with particular care needs by creating interactive web-based communities or through services like NHS Direct Online (a service in UK that provides remote advice and basic triage). There is also a small, but growing literature on the factors that influence successful project implementation. However, it is important to consider how good this evidence base is if we are to use it draw lessons on where to focus our efforts in mainstreaming tele-care [Barlow 2006]. For the above reasons, the systematic evaluations on the outcome of the application of technological solutions seem to be still insufficient, even if common sense and the perception by the care recipient are usually very positive.

In the following table 8 we present a synthesis by Barlow [2006] about some examples of Tele-care modalities, to show the evidence base about their impact on individual and systemic outcomes acquired up to the '90s and the beginning of the century.

Six years after the schematisation is still relevant, even if several studies now provide more evidence [e.g. Audit Scotland 2010; UniQuest 2011; Praxia and Gartner 2011; Cruickshank 2012; SCTT 2012]. Significant additional contributions by the European Project Renewing Health [2012] and by the Whole System Demonstrator (WSD), a case-control study in UK [Department of Health UK 2011] are expected in the following months. This topic will be further discussed in Section 6.3.

Table 8. Examples of evidence base for systemic benefits demonstrated by tele-care applications

Focus of the tele-care application	Examples of evidence on	
	Individual outcomes	Systemic outcomes
Vital signs monitoring	Tele-care aimed at patients with diabetes showing an impact on clinical or care outcomes <b>Emerging evidence base for benefits</b>	Tele-care aimed at patients with diabetes showing a cost benefit impact or impact on processes <b>Some evidence for benefits</b>
Safety and security monitoring	Tele-care aimed at a general population such as all 'frail older people' showing an impact on care outcomes <b>Limited evidence base</b>	telecare aimed at a general population such as all 'frail older people' showing a cost benefit impact or impact on processes <b>Almost no evidence</b>
Information, advice and support	telephone or internet support systems for a community of patients with a specific condition showing an impact on clinical or care outcomes <b>Good evidence base for benefits</b>	telephone or internet support systems for a community of patients with a specific condition showing a cost benefit impact or impact on processes <b>Some evidence for benefits</b>

Source: Barlow (2006).

## 6.2 The governance of the correct adoption of the technologies

Technologies are progressively becoming an essential component of care provision; their deployment cannot remain a spontaneous process, but it should be a direct consequence of the change management in the health and social care organisational models.

An increasing number of countries, regions are adopting innovative technological services within their established policies [e.g. Schug, 2008; The Joint Commission 2008; Gartner 2009; SCTT 2010; Kroes,

2010; Praxia and Gartner 2011; European Commission 2011; COCIR 2011a, b; Cruickshank 2012; Veterans Health Administration 2012; EIP-AHA 2012], following the more reactive large Health Management Organisations [e.g. Kaiser Permanente 2000; Kaye 2010].

A study of Praxia and Gartner [2011] for Canada Infoway provides a view on the level of adoption of 5 major categories of technological services, mainly related to telehealth: monitoring, diagnosis, triage, consultation and procedures (see Figure 4).

Figure 4. Level of adoption of various forms of technological services

<b>Monitoring</b>	<b>Diagnosis</b>	<b>Triage</b>	<b>Consultation</b>	<b>Procedures</b>
Periodic or continual monitoring of vital signs or medication compliance	Using remote clinicians to give medical opinions	Sorting patients according to urgency	Substituting in-person visits with virtual visits	Using remote clinicians to perform procedures
<ul style="list-style-type: none"> <li>• Home Health Monitoring</li> <li>• Mobile Health Monitoring</li> <li>• M-Health</li> <li>• Remote ICU</li> <li>• Remote ECG Monitoring</li> <li>• Digital Plasters</li> <li>• Medication Compliance Management</li> <li>• Smart Pills</li> </ul>	<ul style="list-style-type: none"> <li>• Teleradiology</li> <li>• Teledermatology</li> <li>• Telestroke</li> <li>• Teleretinal Imaging</li> <li>• Telepathology</li> <li>• Tele-audiology</li> </ul>	<ul style="list-style-type: none"> <li>• Medical Call Centers</li> <li>• Teletrauma</li> </ul>	<ul style="list-style-type: none"> <li>• E-Visits</li> <li>• Video Visits</li> <li>• Telepharmacy</li> <li>• Real-Time Virtual Visits</li> <li>• Virtual Medical Assistants</li> <li>• Clinical Kiosks</li> <li>• Rounding Robots</li> </ul>	<ul style="list-style-type: none"> <li>• Telesurgery</li> <li>• Healthcare-Assistive Robots</li> </ul>
<b>Much potential, much hype</b>	<b>Adoption is quietly progressing</b>	<b>In use, being enhanced</b>	<b>Much potential, some usage</b>	<b>In its infancy</b>

Source: Praxia and Gartner (2011).

In the future, it will no more be possible to consider in a separate way the evolution of the healthcare for the chronic conditions and of the social care for the frail and dependent people.

A particular attention should be deserved to the domotic equipment (e.g. surveillance and alarms, or comfort appliances), to the register of the contacts with the formal carers and to the timely indicators of process and outcomes for the proper governance of the system.

In our vision, the most relevant influence by the technologies on the LTC environment will not come from the evolution of the short term, highly fragmented, often consumer-driven market of the ADL equipment, but from the medium-long term systemic changes in the organisation of the whole system of health and social care enabled by the synergy of several technological solutions, and in particular by the changes that will modify the context of the chronic conditions, frailness and “healthy ageing”, which in the longer term will also be supported by new laws and regulations.

The future is always hard to be predictable. In this case, there are too many variables that cannot be controlled:

- which technologies will actually spread, at which costs, providing which functions, how friendly (usability), how far they will result integrated and synergic;
- which regulatory changes will intervene in the medium-long term (e.g. laws about the family-paid home carers);
- how far the innovative organisational models (e.g. disease management) will be fully adopted in a region / country (and when);
- what will be the role of the family as consumers (i.e. when they are buying complementary services and equipment, which are not provided by the public system or by the insurances, with a consequence on equity).

Another significant effect could be envisaged on the joint governance of the health and social care system and on the optimisation of the LTC care provision.

Finally, we should also consider indirect mechanisms, e.g. on the education of the care recipient and of the informal carers, and on their access to knowledge (topics include the management of the LT condition, the citizen's rights, the administrative issues, etc.).

Therefore the most relevant effect will not only be an increase of the market of the equipment or a better coping with defective functions (by independently assisting each care recipient to cope with the daily activities). The focus of the analysis should be extended beyond the mere technological issues, to include all the organisational changes in the whole health and social system (facilitated / allowed by the technologies), in particular the ones dealing with chronic conditions, that in turn will be related to new laws and regulations and will then influence the future of LTC.

The above scenario about the future can only be qualitative: it is impossible to define, for each country or region and for each kind of technological solution, the potential speed of adoption of the diverse technologies, the incentives that will be put in place, the benefits / cost ratio of new technologies that will be put in the market in the next years.

In other words, the studies about the past are of limited use here: look for example at the impossibility to forecast the speed of the diffusion of the Internet and of the related innovative services (e.g. Google, Wikipedia), or at the exceptional speed of diffusion of the cellular phones and – more recently – of the smartphones.

### **6.2.1 *Technology-Assisted LTC as enabler for the citizen-centred care***

In the traditional (institution-centred) healthcare model, care was based on discrete visits and on a less informed decision making process due to the scarce interaction with patients and based mostly on the physician's own training and experience. The recent main change of attitude resides in the concept of anticipating patient's needs (preventing emergency event), concept completely absent in the traditional model which reacts to needs only when they arose, namely the disease is full-blown.

This proactive healthcare model implies several differences. The traditional healthcare model is based on a highly structured hierarchical delivery system dominated by physician and with patients as mere receivers of health services. The new model is shifting towards a paradigm accepting the citizen/care recipient as self-determined individual.

The new paradigm of patient-centred care requires the full involvement (as much as reasonably possible) of citizens in all aspects of healthcare and during all stages of the healthcare value chain, from health information and prevention all the way through to rehabilitation and should be extended also to include Long-Term Care.

Such a paradigm implies also that the term "patient" is reinterpreted towards a meaning as "citizen concerned about their health". Under the new paradigm, a "care recipient" is a person who is well

informed about his/her own illness and health maintenance issues, and interacts with the health and social formal carers on the optimal care path and on the activities best suited to his/her situation. In such a context the care recipient is part of a real dialogue and is no longer only the passive recipient of the care from a formal carer.

Considering these principles, care is based on: continuous relationship, sharing knowledge, fluent information flows and “information-based” decisions, tanks to the ability of packaging, storing, and processing data related to the care activities, improving the decision making process.

Adopting those changes could lead to better levels of quality and to an increased satisfaction for the care recipient; it could also help to restraint the high cost of healthcare. Here we report some significant changes, which are already in progress [Stewart 2001]:

1. The concept of prevention prevails on the concept of diagnosis, treatment focused on monitoring and early detection and management of chronic diseases; the aim is to avoid, at least, the occurrence of complications, favouring primary care over specialty care. Remote Patient Monitoring (RPM) – initially focussed on treatment and limited to a single vital sign and to post-operative situations – is now becoming an effective tool for the prevention of complications in chronic diseases; it is becoming a “continuous monitoring” and its main users are the sub-acute care groups i.e. users needing continuous vital signs monitoring but not continuous nurse care.
2. The site of care is expanding its boundaries going outside the hospital and the clinical setting and moving towards the nursing home and care recipient’s home; favouring outpatient care with respect to inpatient care.
3. Care is enlarging its scope beyond the care recipient domains and is including also the support to people with special needs such as elderly and disabled for an independent living. Care is increasingly addressing new target groups other than the traditional patients; they are elderly and in general people with special needs such as persons with disabilities. By taking into account the ageing of the population, this new and additional “assistive” role of care is very important. Degenerative episodes will be prevented and the need of frequent hospitalisations reduced by supporting the older people to live independently, to slow down their physical and cognitive decay.

Citizen-centred care is a term that is commonly used but not always defined by those using it. As Stewart [2001) states, it is often understood by what it is not: “*technology centred, doctor centred, hospital centred, disease centred*”.

The significance of (true) citizen-centred care is that it moves the focus from the disease to the individual. According to the International Alliance of Patients' Organisation (IAPO, representing patients of all nationalities across all disease areas and promoting patient centred care around the world), the essence of citizen-centred care is that “*the healthcare system is designed and delivered to address the healthcare needs and preferences of patients so that healthcare is appropriate and cost-effective*” [IAPO 2009].

To achieve citizen-centred care at all level in every community, IAPO is calling for the support and collaboration of policy-makers, health providers, service providers to endorse five principle and to make them the centre of their policy and practice.

The five principles typical of citizen-centred care can be summarised as follows:

1. Respect the needs, preferences and values of care recipients and their families.
2. Choice and empowerment: care recipients have a right and responsibility to participate, to their level of ability and preference, in making care decisions.
3. Care recipient organisations involvement in health policy.
4. Access and support to safe, quality services and appropriate care activities.
5. Accurate, relevant and comprehensive Information to make informed decisions.

The involvement of all stakeholders is needed to reorient the care systems towards a citizen-centred attitude; a meaningful care recipient engagement must be central to efforts to refocus health and social systems on people and care recipients.

The above principles provide a basis which recognises that care recipients are individuals and have different needs and that the care system can be responsive to this, encouraging care recipients to take responsibility for their health whilst recognising and respecting the limits in people's ability or individual preferences.

The role of the technologies could be essential to actually enforce the above principles in the LTC milieu, by adapting the care to the individual needs, by enabling the concrete participation of the care recipient and of the informal carers to the care activities, by connecting the care recipients and their families in a network and taking a role in the policy making, and by facilitating the access to services and to information.

### **6.2.2 The Cost-Effectiveness Analysis on the technological applications**

When healthcare services are home-based, benefits do not merely regard spending and resource allocation, but they also comprehend clinical benefits and quality of life improvement. This, in turn, reduces mortality, readmission rates and length of hospital stay in chronic patients; all aspects that provide ground to believe that the technological support to home care presents a valid cost-benefit intervention.

The limited availability of comprehensive health and economic evaluations only offers partial understanding of potential advantages of greater public and private investments in technological services. This represents a major impediment and disincentive for health authorities in investing on new technologies and in promoting reimbursement schemes on technological services.

Cost benefits and cost minimisation analyses could be considered inappropriate to take the right and most appropriate healthcare decision between two treatments alternatives.

Cost minimisation analyses are rarely used in the healthcare field. They assume, in fact, that two alternatives have the same effectiveness in terms of health outcomes, and only differ in terms of costs; decision-makers would therefore only have to consider such difference in costs, and the best alternative would be the less expensive one.

Such approach does not take into account the fact that the two intervention models never have the same clinical outcomes. Furthermore taking a health decision based only on costs without considering clinical outcomes and quality improvements would not fulfil one of the primary final objectives of a health system, which is improving people's health.

Cost-benefits analyses instead take into consideration both changes in costs and health outcomes simultaneously, and express them in monetary value; the most profitable alternative is seen as the best. Although this approach takes into account changes in both variables, the idea of giving a monetary value to outcomes such as quality of life is not always accepted by healthcare decision-makers, mainly because monetising health improvements is often considered inappropriate.

By contrast, Costs-Effectiveness Analyses (CEA) measure benefits in non monetary terms, usually in quality adjusted-life years (QALY), i.e. by a measure of disease burden, including both the quality and the quantity of life lived, which is used in assessing the value for money of a medical intervention. The QALY is based on the number of years of life that would be added by the intervention. Each year in perfect health is assigned the value of 1.0 down to a value of 0.0 for death.

Typically, CEAs are expressed in terms of a ratio ICER (Incremental Cost-Effectiveness Ratio), where the denominator consists of the changes in health effects measured in terms of QALY, years of life, premature birth and so on, while the numerator is the cost associated with the health gain. Thus, cost effectiveness analyses do not select neither the cheapest nor the most profitable alternative, but the one which implies the smallest sacrifice.

In fact CEA includes the concept of “opportunity costs”; this means that in taking a decision there will always be a “sacrifice”, which stands for the value of resources that is given up excluding the alternatives.

As such the idea is to select the option that implies the smallest sacrifice, taking into consideration the overall healthcare context and other possible restrictions alike, such as shortage of beds or professionals in the hospital, etc.

The ANCIEN project is not asked to carry on a new CEA on the sector. Nevertheless, in Chapter 7 it is possible to shortly discuss the benefits and the obstacles related to the massive introduction of the technologies in the LTC sector and more in general in the health sector.

### 6.3 The evidence of the influence of technologies on healthcare

Within the current challenging context, healthcare costs are increasing rapidly, posing fundamental questions on how to achieve sustainable and equitable healthcare systems in Europe. The benefits reachable through the technology may affect different levels, from individual care recipients and the care systems as a whole to the wider European economy.

However, any truly effective intervention on the care sector should be based on the organisational change management; the interventions on healthcare imply also indirect consequences on the composition of the target population that will afterwards require LTC services.

For example, chronic disease-management programmes could have an important influence on Technology-Assisted LTC. According to the World Health Organisation a chronic disease is to be defined as a “disease of long duration and generally slow progression”.

The technologies enable healthcare professionals to monitor and diagnose health conditions by remotely collecting, storing, retrieving and analysing vital patient health signs for chronic conditions such as heart failure, diabetes, and chronic obstructive pulmonary diseases (COPD).

A program on Chronic Disease Management implies a strong influence on the present and future conditions of elderly and frail people, and thus on the related LTC provision.

Preliminary data from the large case-control trial of WSD [Department of Health 2011] about care models with the presence/absence of technologies, show that

*“if used correctly telehealth can deliver a 15% reduction in A&E visits, a 20% reduction in emergency admissions, a 14% reduction in elective admissions, a 14% reduction in bed days and an 8% reduction in tariff costs. More strikingly they also demonstrate a 45% reduction in mortality rates”.*

For instance, this effect emerges also in [Illinois Health Connect 2010]. On page 8 it is stated that:

*“During its first 3 years of operation, McKesson has reported a \$307 million savings to Illinois taxpayers. Among its key clinical achievements*

- *15.5% increase in annual influenza vaccination rate*
- *22% increase in pneumococcal vaccination rates*
- *20% increase in patients having an asthma action plan*
- *7% increase in annual dilated retinal exams for persons with diabetes*
- *33% decreased hospital utilisation for persons with persistent asthma*
- *5% decreased hospital utilisation for adults with disabilities.”*

Note that the report is not mentioning the technological issues, but nevertheless this kind of intervention (with the related outcomes and their measurement) is absolutely not possible without an adequate usage of innovative care models enabled by the technology.

This approach is opposite, for example, to most of the eHealth adoption plans, which usually involve “horizontal”, infrastructural initiatives driven by the opportunities offered by the ICT solutions,



whereas the priorities of health action plans are based on problem-oriented, “vertical” initiatives targeted to specific sub-populations.

The new approach involves a dramatic cultural change, which is closely linking the organisational and technological ones. It involves also a well-defined action by the top decision makers on the technology side. Certainly, it will be difficult to assess, for each jurisdiction, which level of cultural and organisational change already occurred spontaneously in that direction at the moment in which a planned effort will be put in place, and at which point the driving forces by the governments, the consumers and the healthcare providers will meet.

In turn, the growing scale of the transformations requires the intervention of the top decision makers in governments and insurances / HMOs and new regulations / rules of the game.

Again from [Illinois Health Connect 2010], page 4: *“The rise of Primary Care Case Management (PCCM) programs over the last two decades can be directly attributed to rising healthcare costs and the increasing burden of chronic disease in the United States. [...] With strong emphases on disease management and redesigned payment mechanisms that reward care coordination, case management and quality healthcare for patients over high volume, these programs have met with initial success in terms of patient/provider satisfaction, improved quality metrics, and early cost savings to the state.”*

May be in the future the new organisational models will properly include also the LTC milieu, building on the Chronic Care Model and the generic goal of ‘integrating health and social care’, embedding the technologies as an intrinsic resource to cope with the holistic health and wellness of the individuals.

## **7. Benefits and obstacles related to the Technology-Assisted LTC**

In the last decades healthcare approach is moving from the traditional healthcare model to a new model focused on a patient centric approach.

The need of a new healthcare model has been recognised by the European Commission: *“The way healthcare is presently delivered has to be deeply reformed. The situation is becoming unsustainable and will only worsen in the future, as chronic disease and the demographic change place additional strains on healthcare systems around Europe”* [DG INFSO 2006].

The integration between social and health care is slowly becoming an objective of several jurisdictions. They call for a new care delivery model based on preventative and person-centred health and social systems. We claim that this new model can be achieved in full only through the proper use of technologies as required by the appropriate organisational changes.

### **7.1 Potential benefits**

The Technology-Assisted LTC can have a significant impact on quality of life and longevity gains. The basic concept is that the individuals improve their health, because the impairments are (partially) compensated and diseases and symptoms are treated appropriately and preventively.

Examples of possible consequences are:

- a number of informal carers don’t have to subtract as much time away from work and thus may be more productive giving a greater contribution to the total economic growth.
- thanks to improved communication and smart devices, care services overcomes the geographical barrier and may be provided locally so people don't have to travel out of the community.
- the e-learning initiatives for workforce development / jobs can help to address the shortage of care professionals.

In particular, in the perspective of the care recipient, we could consider the following benefits:

- Remote access to timely care, regular monitoring of progresses.

- Saving time and travel costs; care professionals can timely “meet” care recipients by virtual means.
- Health provider integration and seamless care, supported collaboration among formal and informal carers
- Increased acceptability and satisfaction, due to easiness of use, affordability and usefulness
- Care recipient may become more active in their own care by explicit or implicit education

In the perspective of the providers, the advantages could include the following ones:

- Better use of resources by supporting self-management and avoiding accidents or delaying complications
- Decreased professional isolation and improved professional online support
- Accuracy of assessments and reduction of inappropriate decisions

The final results is a care system with a more efficient resource allocation, able to take better clinical decisions increasing the quality of care and to guarantee more equity in terms of quality and accessibility, leading to more “service appropriateness”, i.e. to deliver the right care service to the right care recipient (and the right informal carer), at the right time, in the right setting.

## 7.2 Challenges and barriers to adoption

Despite the technology maturity and the potential benefits, the technological innovation still covers a secondary role in the social care context. In particular the tele-care, according to the Capgemini report [Valeri 2010], is accounting for a mere 0,9% of the total e-health market in 2008, even though this percentage is expected to increase in the following years.

The need of a citizen-centric care system, assisted by the technologies, has been recognised by EU Member States, regional and local authorities, by payers of healthcare services, industry and even by the European Commission, which have been supporting research in the field of technological innovations in the health sector for over 20 years [Commission Staff 2009].

About “telemedicine” (in a broad sense), the Commission supports the initiatives to achieve the following three objectives [Kroes, 2010]:

- Building acceptance of telemedicine services in health professional and care recipients;
- Bringing legal clarity on existing EU legislation regarding telemedicine services and encourage Member States to improve provision of telemedicine services;
- Solving technical issues and facilitating market development such as the lack of adequate community-wide broadband infrastructure and interoperability of telemedicine devices.

In the following paragraphs we bring further the implications of this approach in the case of the potential future influences all the technologies on the LTC milieu.

### 7.2.1 Acceptance of technologies

Trust in benefits in terms of outcomes and costs is the base of all future development and technical progress. Policy makers and institutions need further proofs of the benefits, especially in terms of return on investments and costs-saving, because the studies published until now not represent a valid evidence based.

Another issue is the resistance of the users to Technology-Assisted LTC. In the LTC milieu, more than in other services/goods, the human component covers a fundamental role for the success of the whole care process. Human factors are usually the major cause of all incidents in healthcare and they include not only the wrong behaviour, but also issues linked to the learning and the skill about how decision are made or communicated or performance is conducted. Care recipients on the other hand may feel uncomfortable communicating on video or being electronically monitored.

Human factor component is relevant in the specific case of LTC where a great number of care recipients enrolled in home care programs are senior citizens and often have functional limitations due to aging or their clinical conditions. The reduced sensory, cognitive or motor capabilities make the usability and user friendliness important quality criteria for the home based applications, which should be used by elderly care recipients and informal carers usually with no technological experience.

Moreover, a comprehensive innovation program should include a staff training program also on topics that are usually undervalued, e.g. a specific training is required for formal carers about the managements of remote consultations for the delivery of advanced services.

### **7.2.2 Legal clarity and regulations**

The economic and legal issues about the innovative models in Long-Term Care assisted by technology include the reimbursement, the accreditation and the liability.

About reimbursement, in many jurisdictions there is a lack of a “business model” on remote services that allows to take into account the various sub-activities performed by the formal carers within a shared care plan. In the reallocation of the activities among the formal carers (and their respective organisations) in the new organisational models, a change in the redistribution of reimbursements will also occur, creating a resistance in the providers that loose a part of their income.

Several specific issues are related to the various modalities of provision of remote professional care. It involves for example the “shared liability” for malpractice of remote and local providers or it may amplify some conflicts among the laws in the local and remote jurisdictions; moreover, to assure the quality of the services, some form of accreditation should be enforced, recognised in the local and remote jurisdictions.

### **7.2.3 Privacy and security**

Privacy and security are two major components of building trust in technological systems involved in care provision [Kroes, 2010].

Security means that information can be communicated or stored in such a manner that it cannot be lost or altered by an intrusion (integrity) and that access is limited to authorised parties (privacy and authentication).

### **7.2.4 Connectivity to rural and remote communities**

Broadband access to support the data transmission and the ability of providers to enable full connectivity is a prerequisite for the future deployment of massive advanced services, and this may be a problem in several rural areas.

The success of the integration of smart home equipment and ICT relies on the availability of the technological infrastructure able to support a significant increase of traffic from the home of the care recipients.

## **Conclusions**

In the last decades the name of the eHealth sector was experiencing a trend from “medical informatics” to “healthcare informatics”, to “ICT for health”, up to the current “eHealth”, reflecting the evolution of the way of thinking (i.e. the awareness) of the decision makers and of the driving forces behind. Some countries already envisage the next step towards a “connected health”; eventually, in future the maturity of the technological to support care processes will be finally recognised, when it will be the time to drop any adjective, from “eHealth” or “connected health” to just “health”.

At the same time the power and the friendliness of equipment conceived for the care recipients and their informal carers are increasing at the same speed at which the costs and the size are decreasing.

From the side of care provision, it is also increasing the awareness that in the future healthcare and social care should be fully integrate in the holistic concepts of health and wellness.

The current disproportionate attention of most e-government plans on technology-focussed interventions should to be replaced by a more correct focus on the health issues, with an explicit, correctly planned organisational transformation, which will not necessarily mention the technology (and in particular the ICT) as a priority, but will anyhow use it as an enabling factor.

In other words, the usage of the technologies, which will necessarily be behind the scene, should eventually be considered as a “normal” component and given as understood by the policy makers, who should instead put the emphasis on the process of organisational change (and on its motivations).

The propagation of this innovation is not hampered by the lack of technological solutions, but by regulatory, economic, organisational and cultural problems, by the absence of a constructive debate and a widespread awareness about the available opportunities and by the chronic shortage of innovators to manage the change processes within the LTC structures.

**Many low-tech tools were already introduced in the LTC milieu, to support the care recipient about the functions related to the ADL and IADL. It is then possible to foresee that the future changes in this sector will not have particularly significant impact on the reciprocal roles of the LTC actors.**

However, it could be possible to use the ICT technologies to facilitate the further dissemination of these technologies, by organising an effective network of national and regional guidance centres and show rooms for citizens and decision makers, with local ‘counters’, supported by a European coordination infrastructure (including common documentation resources and an agreed nomenclature of the technological equipment and services for LTC).

Instead, the combined massive introduction in the health and social care of the technologies of smart home equipment and ICT solutions will probably influence dramatically the LTC sector by three complementary direct and indirect mechanisms:

- the ability, for each actor involved in the LTC care, to perform activities that are currently performed by more skilled actors, preserving the quality and the effectiveness of the outcomes. It implies in particular an increase in the engagement of the care recipient, and a more effective role of the informal carers, with more opportunities for the care recipient to remain at home.
- the usage of ICT to improve the care organisation and the optimal allocation of resources, through timely and accurate quality indicators systematically derived from more reliable routine data, validated by the use for multiple purposes in the care processes.
- the movement of healthcare towards a proactive attitude, to prevent risks and to delay the consequences of the diseases (in particular, the Chronic Disease Management assisted by the technologies), that could be expected to modify the future patterns of prevalence of the various kinds of impairments to be faced by LTC.

In summary:

We envisage a strong indirect influence on the LTC milieu  
by large organisational changes enabled by the introduction  
of a large set of integrated technological solutions,  
within well-planned initiatives on “health” promotion and maintenance  
(in the holistic meaning involving both health and social care).

In fact, it will not possible to isolate the LTC sector  
from the phenomena of the care transformation occurring worldwide,  
i.e. from the evolution of the organisational models

forced by the need of economic sustainability of the care  
plus the increasing awareness of the citizens  
about their rights about a holistic health.

We claim that the order of magnitude of this impact will be far bigger  
than the one due to the “spontaneous” deployment of ICT  
and in turn it will be bigger than the one due to  
the evolution of all the specific equipment or low-tech tools.

## References

- AAL (2011). “Ambient Assisted Living Joint Programme”, <http://www.aal-europe.eu/>
- ANCIEN Consortium (2009). “A short introduction to ANCIEN - Assessing Needs of Care In European Nations”, <http://www.ancien-longtermcare.eu/>
- Audit Scotland (2010). “A review of telehealth in Scotland”. Edinburgh, <http://www.audit-scotland.gov.uk/media/article.php?id=178> ; [http://www.audit-scotland.gov.uk/docs/health/2011/nr\\_111013\\_telehealth\\_bw.pdf](http://www.audit-scotland.gov.uk/docs/health/2011/nr_111013_telehealth_bw.pdf)
- Barlow, et al (2006). “Building an evidence base for successful telecare implementation – updated report of the Evidence Working Group of the Telecare Policy Collaborative chaired by James Barlow” – November 2006 [http://www.telecare.org.uk/information/45779/46315/46331/46347/telecare\\_evidence/](http://www.telecare.org.uk/information/45779/46315/46331/46347/telecare_evidence/)
- Barrett, MJ (2006). “Patient Self-Management Tools: An Overview, California HealthCare Foundation”, June 2006, <http://www.chcf.org/~media/Files/PDF/P/PDF%20PatientSelfManagementToolsOverview.pdf>
- Berkowitz, EN (2000). “Essentials of Health Care Marketing”, IOS Press
- Brownsell, S (2008). “Supporting Long-Term Conditions and disease management through Telecare and Telehealth: evidence and challenges”, CSIP (Care Services Improvement Partnership), [http://www.icn.csip.org.uk/\\_library/Resources/Telecare/Support\\_Materials/Briefing\\_-\\_Telehealth\\_SB\\_Final2.doc](http://www.icn.csip.org.uk/_library/Resources/Telecare/Support_Materials/Briefing_-_Telehealth_SB_Final2.doc)
- CEN (1996). “ENV 12611 Medical Informatics - Categorical structure of systems of concepts - Medical Devices”
- Chien, E, Geffen, M, Gordon, D (eds.) (2011). “Telehealth Benefits and Adoption - Connecting People and Providers Across Canada.” A Study Commissioned by Canada Health Infoway, 30 May 2011
- Clifford, R (2010). “Financial and externality impact of high speed broadband for Tele-health”, Access Economics Department , July 2010
- COCIR (European Coordination Committee of the Radiological, Electromedical and Healthcare IT Industry) (2011a). “COCIR Telemedicine toolkit - supporting effective deployment of telehealth and mobile health”. COCIR, Bruxelles, May 2011 [http://www.cocir.org/uploads/documents/1184-1184-telemedicine\\_toolkit\\_link2.pdf](http://www.cocir.org/uploads/documents/1184-1184-telemedicine_toolkit_link2.pdf)
- COCIR (European Coordination Committee of the Radiological, Electromedical and Healthcare IT Industry) (2011b). “COCIR eHealth toolkit - for an accelerated deployment and better use of ehealth”. COCIR, Bruxelles, May 2011” [http://www.cocir.org/uploads/documents/1185-1185-ehealth\\_toolkit\\_link2.pdf](http://www.cocir.org/uploads/documents/1185-1185-ehealth_toolkit_link2.pdf)
- Collopy, B, Dubler, N, Zuckerman, C et al (1990). “The Ethics of Home Care: Autonomy and Accommodation”, The Ethics of Home Care: Autonomy and Accommodation, The Hastings Center Report, Vol. 20, No. 2. (Mar. - Apr., 1990), pp. 1-16.
- Commission Staff Working Paper (2009), “Telemedicine for the benefit of patients, healthcare systems and society - 943 final”, EU Commission, June 2009
- Continua Health Alliance (2009). “Connected health vision, personal telehealth overview” <http://www.continuaalliance.org/connected-health-vision.html>; see also: <http://www.ehealthserver.com/continua/357-connected-care-market-poised-for-growth-as-new-solutions-promise-to-transform-healthcare-delivery>
- Council of the European Union (2007). “Joint Report on Social Protection and Social Inclusion 2007”. [http://ec.europa.eu/employment\\_social/social\\_inclusion](http://ec.europa.eu/employment_social/social_inclusion)

- Crosby, LA, Stephens, N (1987). "Effects of relationship marketing on satisfaction, retention, and prices in the life insurance industry". *Journal of Marketing Research*, 1987, 24(4), 404-411.
- Cruickshank, J (2012). "Telehealth. What can the NHS learn from experience at the US Veterans Health Administration?" January 2012, 2020health.org, London  
<http://www.2020health.org/2020health/Publication/NHSit/Telehealth.html> ;  
<http://www.2020health.org/dms/2020health/downloads/reports/Telehealth-VA/Telehealth%20VA.pdf> ;
- CTA - Center for Technology and Aging (2009a). "Technologies for Optimizing Medication Use in Older Adults", Position Paper, October 2009,  
<http://www.techandaging.org/MedOpPositionPaper.pdf>
- CTA - Center for Technology and Aging (2009b). "Technologies to Help Older Adults Maintain Independence: Advancing Technology Adoption", Briefing Paper, July 2009,  
<http://www.techandaging.org/briefingpaper.pdf>
- Dansky, KH, Palmer, L et al (2001). "Cost Analysis of Tele home care", *Telemedicine Journal and e-Health* Volume 7, Number 3
- Darkins, AW, Cary, MA (2000). "Telemedicine and telehealth: principles, policies, performance" Springer Publishing Company
- Department of Health UK (2011). "The WSD Programme Headlines Findings (December 2011) [[http://www.dh.gov.uk/dr\\_consum\\_dh/groups/dh\\_digitalassets/documents/digitalasset/dh\\_131689.pdf](http://www.dh.gov.uk/dr_consum_dh/groups/dh_digitalassets/documents/digitalasset/dh_131689.pdf)]
- Department of Health, UK (2000). "The Royal Commission on Long-Term Care was set up to examine short and long term options for funding Long-Term Care for older people", Department of Health, 0101481837 Cm 4818-II, 2000
- Department of Health, UK (2004). "Improving Chronic Disease Management".  
[http://www.dh.gov.uk/prod\\_consum\\_dh/groups/dh\\_digitalassets/@dh/@en/documents/digitalasset/dh\\_4075213.pdf](http://www.dh.gov.uk/prod_consum_dh/groups/dh_digitalassets/@dh/@en/documents/digitalasset/dh_4075213.pdf)
- Department of Health, UK (2005). "Self care. A real Choice, Self Care Support- A Practical Option"
- Department of Health, UK (2006a). "Our Health our care, our say" White Paper
- Department of Health, UK (2006b). "Supporting people with Long-Term Conditions to self care: a guide to developing local strategies".  
[http://www.dh.gov.uk/en/Publicationsandstatistics/Publications/PublicationsPolicyAndGuidance/DH\\_4130725](http://www.dh.gov.uk/en/Publicationsandstatistics/Publications/PublicationsPolicyAndGuidance/DH_4130725)
- Department of Health, UK (2007). "Research Evidence On The Effectiveness Of Self Care Support"
- Department of Health, UK (2008). "Research and development work relating to assistive technology 2007-08"
- Department of Health, UK (2010). "Research and Development Work Relating to Assistive Technology 2009-10"  
[http://www.dh.gov.uk/en/Publicationsandstatistics/Publications/PublicationsPolicyAndGuidance/DH\\_122344](http://www.dh.gov.uk/en/Publicationsandstatistics/Publications/PublicationsPolicyAndGuidance/DH_122344)
- DG INFSO - Information Society and Media (2006). "ICT for Health and i2010 Transforming the European healthcare landscape Towards a strategy for ICT for Health", EU Commission, June 2006
- DG REGIO (2011). "Good practice on ICT & Ageing solutions",  
[http://ec.europa.eu/information\\_society/activities/einclusion/policy/ageing/action\\_plan/index\\_en.htm](http://ec.europa.eu/information_society/activities/einclusion/policy/ageing/action_plan/index_en.htm)

- e-inclusion Programme (2011). “The Ageing Well in the Information Society Action Plan”, [http://ec.europa.eu/information\\_society/activities/einclusion/policy/ageing/action\\_plan/index\\_en.htm](http://ec.europa.eu/information_society/activities/einclusion/policy/ageing/action_plan/index_en.htm)
- eHealth ERA (Towards the Establishment of a European eHealth Research Area) (2007). Report “eHealth priorities and strategies in European countries”, <http://www.ehealth-era.org/index.htm>
- EIP-AHA (2012). “European Innovation Partnership on Active and Healthy Ageing” [http://ec.europa.eu/research/innovation-union/index\\_en.cfm?section=active-healthy-ageing](http://ec.europa.eu/research/innovation-union/index_en.cfm?section=active-healthy-ageing)
- empirica and WRC (2010). “ICT & Ageing. European Study on Users, Markets and Technologies” Final Report. January, 2010. Report prepared by on behalf of the European Commission, Directorate General for Information Society and Media
- European Commission (2007). “Accelerating the Development of the eHealth Market in Europe. eHealth Taskforce report 2007”, 2007, [http://ec.europa.eu/enterprise/policies/innovation/policy/lead-market-initiative/ehealth/index\\_en.htm](http://ec.europa.eu/enterprise/policies/innovation/policy/lead-market-initiative/ehealth/index_en.htm)
- European Commission (2008). “Telemedicine for the benefit of patients, healthcare systems and society”, COM(2008) 689
- European Commission (2009). “Telemedicine for the benefit of patients, healthcare systems and society” Staff Working Paper SEC(2009)943, June 2009
- European Commission (2011). “Digital Agenda for Europe”, 2011, [http://ec.europa.eu/information\\_society/digital-agenda/index\\_en.htm](http://ec.europa.eu/information_society/digital-agenda/index_en.htm)
- European Parliament And The Council (2007). “Directive 2007/47/EC of 5 September 2007, amending Council Directive 90/385/EEC on the approximation of the laws of the Member States, relating to active implantable Medical Devices, Council Directive 93/42/EEC concerning Medical Devices and Directive 98/8/EC concerning the placing of biomedical products on the market”
- Family-friendly-fun website (2012). “Adaptive equipment”, <http://www.family-friendly-fun.com/disabilities/adaptive-equipment.htm>
- Gartner, (2009). “eHealth for a Healthier Europe! – opportunities for a better use of healthcare resources”, Swedish Presidency of the European Union,
- Grönroos, C. “Service Management And Marketing: Customer Management “, John Wiley & Sons (2007)
- IAPO (International Alliance of Patients’ Organizations) (2009). “International Alliance of Patients’ Organizations. Declaration on patient-centred healthcare” London
- ICT for Health Unit (2011). “ICT for better Healthcare in Europe”, [http://ec.europa.eu/information\\_society/activities/health/index\\_en.htm](http://ec.europa.eu/information_society/activities/health/index_en.htm)
- Illinois Health Connect (2010). “Case Statement”, Illinois Academy of Family Physicians and The Robert Graham Center, August 2010, <http://www.graham-center.org/online/graham/home/publications/monographs-books/2010/ilafp-case-statement.html>
- IPTS (Institute for Prospective Technological Studies) (2009). “Strategic Intelligence Monitor on Personal Health Systems” (SIMPHS), <http://is.jrc.ec.europa.eu/pages/TFS/sps.html>
- IPTS (Institute for Prospective Technological Studies) (2011). "The role of ICT and migrants for addressing Long-Term Care challenges in an ageing society", [http://is.jrc.ec.europa.eu/pages/EAP/documents/IPTSresearchonICTIEMcarers\\_overview.pdf](http://is.jrc.ec.europa.eu/pages/EAP/documents/IPTSresearchonICTIEMcarers_overview.pdf)



- Joint Commission (2008). "Health Care at Crossroads: Guiding Principles for the Development of the Hospital of the Future", [http://www.jointcommission.org/NR/rdonlyres/1C9A7079-7A29-4658-B80D-A7DF8771309B/0/Hospital\\_Future.pdf](http://www.jointcommission.org/NR/rdonlyres/1C9A7079-7A29-4658-B80D-A7DF8771309B/0/Hospital_Future.pdf)
- Jossei-Bass (2002). "E-Health, Tele-health, and telemedicine: a guide to start-up and success", Wiley
- Kaiser Permanente (2000). "Outcomes of the Kaiser Permanente Tele-Home Health Research Project", *Arch Fam Med.* 2000;9:40-45
- Kaiser Permanente (2012). "My Health Manager", <https://healthy.kaiserpermanente.org/health/care/consumer/my-health-manager>
- Kandampully, J (1998). "Service Quality to service Loyalty: A relationship which goes beyond customer service" *Total Quality Management* Vol. 9, 6,431-443, 1998
- Kaye, R, Kokia, E, et al (2010). "Barriers and success factors in health information technology: A practitioner's perspective". *Journal of Management & Marketing in Healthcare.* VOL. 3 NO. 2. PP 163–175. June 2010, <http://www.maccabi-research.org/res/pdf/barriers.pdf>
- Kroes, N (2010). "Telemedicine and Infrastructures in Europe", in: "The Telemedicine Challenge in Europe" *The European Files*, n.20, June-July 2010, EU Commission, Bruxelles [http://ec.europa.eu/information\\_society/activities/health/docs/publications/2010/2010europ-files-telemedicine\\_en.pdf](http://ec.europa.eu/information_society/activities/health/docs/publications/2010/2010europ-files-telemedicine_en.pdf)
- Lymberis, A, De Rossi, DE (2004). "Wearable e-health systems for personalised health management system", IOS Press,
- Maggini, M, Raschetti, R, Rossi Mori, A et al (2008). "Requisiti informativi per un sistema di gestione integrata del diabete mellito di tipo 2 nell'adulto: documento di indirizzo". Roma, Pensiero Scientifico Editore, <http://www.epicentro.iss.it/igea/documenti/documentiIGEA.asp>
- Martyn, D (2002). "The experiences and views of self-management of people with a schizophrenia diagnosis", 2002 <http://www.rethink.org/recovery/self-management/Initial Report.pdf>
- NEHI (2009) New England Healthcare Institute. "Thinking Outside the Pillbox: A System-wide Approach to Improving Patient Medication Adherence for Chronic Disease", August 2009, [http://www.nehi.net/publications/44/thinking\\_outside\\_the\\_pillbox\\_a\\_systemwide\\_approach\\_to\\_improving\\_patient\\_medication\\_adherence\\_for\\_chronic\\_disease](http://www.nehi.net/publications/44/thinking_outside_the_pillbox_a_systemwide_approach_to_improving_patient_medication_adherence_for_chronic_disease)
- OECD-NSF (2011). Workshop "Building a smarter health and wellness future", Washington, 15-16 February 2011 <http://www.oecd.org/sti/smarterhealth>
- Praxia and Gartner (2011). "Telehealth Benefits and Adoption. Connecting People and Providers Across Canada" May 30th 2011, <https://www.infoway-inforoute.ca/about-infoway/approach/investment-programs/telehealth>; [https://www2.infoway-inforoute.ca/Documents/telehealth\\_report\\_2010\\_en.pdf](https://www2.infoway-inforoute.ca/Documents/telehealth_report_2010_en.pdf)
- Renewing Health (2012) Portal of the project "REgionNs of Europe WorkINg toGether for HEALTH" <http://www.renewinghealth.eu/>
- Rigby, M (ed) (2010). "Declaration by the Members of the European Science Foundation Exploratory Workshop on Social Care Informatics and Holistic Health Care", Keele University, UK, July 2010, "Social Care Informatics meets Health Care Informatics – a Holistic Citizen-Centric Vision for Information and Communication Technologies to Support Personal Health" <http://iig.uit.at/dokumente/n29.pdf>
- Rojas, SV, Gagnon, MP (2008). "A systematic review of the key indicators for assessing Tele-home care cost-effectiveness". *Telemed J E Health.* Nov;14(9):896-904. ICESI University, Cali, Colombia.
- Rossi Mori, A (2007c). Position Statement: "Connecting systems or connecting people?", Panel: "Ptolemaic vs. Copernican - How healthcare policies and re-organisation of care provision will

- influence the eHealth roadmaps". International conference "Continuity, Collaboration, Communication: Challenges for Healthcare and Opportunities for eHealth", Rome, 24-25 May 2007, jointly organised by EHTEL, the National Research Council of Italy - Institute for Biomedical Technology in co-operation with CPME, EFN, HOPE, PGEU, UEMS, <http://www.ehtel.org/forum/conferences/roma-24-maggio-2007>
- Rossi Mori, A (2009). "A Framework for Telemedicine and Chronic Disease Management". Workshop "Tele-enabled Healthcare - The Voice from the Field", in cooperation with the "Task Force Sustainable Telemedicine and Chronic Disease Management" of EHTEL, Med-e-Tel, Luxembourg, 2009-04-01
- Rossi Mori, A (2012). "The policies on Connected Health are essential to achieve accountable social and health systems" submitted to the ePractice issue on "Policy lessons from a decade of eGovernment, eHealth & eInclusion"
- Rossi Mori, A et al (2007a). "Towards a European Roadmap for Achieving eHealth Interoperability". eHealth Berlin Conference 2007-04-18, Special Interest Session II "Electronic Health Records and Interoperability", Co-Organised by the RIDE Project and the EuroRec Institute, Accessed on Nov. 16, 2009 from [http://www.eurorec.org/news\\_events/newsArchive.cfm?newsID=142](http://www.eurorec.org/news_events/newsArchive.cfm?newsID=142)
- Rossi Mori, A et al (2007b). "Policies and strategies". Deliverable of the EU Coordination Action "RIDE - A Roadmap for Interoperability of eHealth Systems in Support of COM 356with Special Emphasis on Semantic Interoperability", <http://www.srdc.metu.edu.tr/webpage/projects/ride/modules.php?name=Deliverables>  
<http://www.srdc.metu.edu.tr/webpage/projects/ride/deliverables/RIDE-D4.3.1%20policies%20final%20v06a.doc>
- Rossi Mori, A et al (2008a). "eHealth deployment roadmap and roll-out planning: Guiding design principles". Proceedings of the "eHealth Planning and Management Symposium 2008" - EuroRec Annual Conference 2008-11-03 Copenhagen in a joint meeting with EHTEL, <http://www.ehtel.org/forum/conferences/ehealth-planning>
- Rossi Mori, A, Mazzeo M, D'Auria S (2009). "Deploying Connected Health among the Actors on Chronic Conditions." European Journal of ePractice N° 8. December 2009 [http://www.epractice.eu/files/European%20Journal%20epractice%20Volume%208\\_1.pdf](http://www.epractice.eu/files/European%20Journal%20epractice%20Volume%208_1.pdf)
- Rossi Mori, A, Mercurio, G et al. (2008b) "Focused Profiles for Chronic Patients in Integrated Care and Clinical Governance" 9th International HL7 Interoperability Conference - IHIC 2008, Crete, Greece, [http://www.hl7.org.gr/ihic2008/9o\\_congress/ihic\\_2008.html](http://www.hl7.org.gr/ihic2008/9o_congress/ihic_2008.html)
- Schug, SH (Editor-in-Chief) (2008). "Sustainable Telemedicine: paradigms for future-proof healthcare - A Briefing Paper". Version 1.0, 20 February 2008, <http://www.ehtel.org/forum/tasks-sources/task-force-sustainable-telemedicine-and-chronic-disease-management/ehtel-briefing-paper-sustainable-telemedicine-paradigms-for-future-proof-healthcare-1>
- SCTT (2010). "Scottish Centre for Telehealth Strategic Framework 2010 – 2012" Version 1.3, April 2010. <http://www.sctt.scot.nhs.uk/strategy.html>; <http://www.sctt.scot.nhs.uk/pdf/strategy.pdf>
- SCTT (2012). "Scottish Centre for Telehealth & Telecare. Current Research Papers" <http://www.sctt.scot.nhs.uk/research.html>
- Spil TAM, Schuring R (2006). "E-health systems diffusion and use: the innovation, and the user" Idea Group Publishing
- Stewart, M (2001). "Towards a global definition of patient centred care" BMJ Journals 2001; 322: 444
- Stewart, S, Blue, L et al (2001). "An economic analysis of specialist heart failure nurse management in the U.K. Can we afford not to implement it?" European Heart Journal, doi: 10.1053/euhj.2001.3114

- Tak, SH, Benefield, LE, Mahoney, DF (2010). "Technology for Long-Term Care" Research in Gerontological Nursing Vol.3, No.1
- Ulieru, M, Palensky P, Doursat R. (2008) "IT Revolution: First International ICST Conference, IT Revolutions 2008" Springer ICST
- UniQuest (2011) "Telehealth Assessment Final Report". Prepared for Department of Health and Ageing, Project No: 16807, 28 June 2011, [http://www.mbsonline.gov.au/internet/mbsonline/publishing.nsf/Content/EC471B2E09EE7370CA2578A4001092BE/\\$File/UniQuest%20Telehealth%20Assessment%20Report%20.pdf](http://www.mbsonline.gov.au/internet/mbsonline/publishing.nsf/Content/EC471B2E09EE7370CA2578A4001092BE/$File/UniQuest%20Telehealth%20Assessment%20Report%20.pdf)
- Valeri, L, Giensen, D. (2010) "Business Models for e-Health Final Report", Capgemini Consulting prepared for ICT for Health Unit, DG Information Society and Media, European Commission 28 February 2010
- Veterans Health Administration (2012). "My HealthVet", <http://www.myhealth.va.gov/>
- Wagner, EH et al (2002). "Improving Chronic Illness Care: Translating Evidence Into Action", JAMA, October 9, 2002 – Vol 288, No. 14.
- Westbrook, JI et al (2007) "Information Technology in Healthcare 2007 ", IOS Press

**L**aunched in January 2009, ANCIEN is a research project financed under the 7th EU Research Framework Programme. It runs for a 44-month period and involves 20 partners from EU member states. The project principally concerns the future of long-term care (LTC) for the elderly in Europe and addresses two questions in particular:

- 1) How will need, demand, supply and use of LTC develop?
- 2) How do different systems of LTC perform?

The project proceeds in consecutive steps of collecting and analysing information and projecting future scenarios on long-term care needs, use, quality assurance and system performance. State-of-the-art demographic, epidemiological and econometric modelling is used to interpret and project needs, supply and use of long-term care over future time periods for different LTC systems.

**Work Packages.** The project started with collecting information and data to portray long-term care in Europe (WP 1). After establishing a framework for individual country reports, including data templates, information was collected and typologies of LTC systems were created. The collected data form the basis of estimates of actual and future long term care needs in selected countries (WP 2). WP 3 builds on the estimates of needs to characterise the response: the provision and determinants of formal and informal care across European long-term care systems. Special emphasis is put on identifying the impact of regulation on the choice of care and the supply of caregivers. WP 6 integrates the results of WPs 1, 2 and 3 using econometric micro and macro-modelling, translating the projected needs derived from WP2 into projected use by using the behavioral models developed in WP3, taking into account the availability and regulation of formal and informal care and the potential use of technological developments.

On the back of projected needs, provisions and use in European LTC systems, WP 4 addresses developing technology as a factor in the process of change occurring in long-term care. This project will work out general principles for coping with the role of evolving technology, considering the cultural, economic, regulatory and organisational conditions. WP 5 addresses quality assurance. Together with WP 1, WP 5 reviews the policies on LTC quality assurance and the quality indicators in the EU member states, and assesses strengths, weaknesses, opportunities and threats of the various quality assurance policies. Finally WP 7 analyses systems performance, identifying best practices and studying trade-offs between quality, accessibility and affordability.

The final result of all work packages is a comprehensive overview of the long term care systems of EU nations, a description and projection of needs, provision and use for selected countries combined with a description of systems, and of quality assurance and an analysis of systems performance.

#### Principal and Partner Institutes

CEPS is responsible for administrative coordination and dissemination of the general results (WP 8 and 9). The Belgian Federal Planning Bureau (FPB) and the Netherlands Bureau for Economic Policy Analysis (CPB) are responsible for scientific coordination. Other partners include: German Institute for Economic Research (DIW); Netherlands Interdisciplinary Demographic Institute (NIDI); Fundación de Estudios de Economía Aplicada (FEDEA); Consiglio Nazionale delle Ricerche (CNR); Università Luiss Guido Carli-Luiss Business School (LUISS-LBS); Institute for Advanced Studies (IHS); London School of Economics and Political Science- Personal Social Services Research Unit (PSSRU); Istituto di Studi e Analisi Economica (ISAE); Center for Social and Economic Research (CASE); Institute for Economic Research (IER); Social Research Institute (TARKI); The Research Institute of the Finnish Economy (ETLA); Université de Paris-Dauphine-Laboratoire d'Economie et de Gestion des organisations de Santé (DAUPHINE- LEGOS); University of Stockholm, Department of Economics; Karolinska Institute-Department of Medicine, Clinical Epidemiology Unit ; Institute of Economic Research, Slovak Academy of Sciences (SAS-BIER); Center for Policy studies (PRAXIS). Most of the ANCIEN partners are members of the European Network of Economic Policy Research Institutes (ENEPRI).