

BETTER PLOWING



CIRCULAR 450

UNIVERSITY OF ILLINOIS • COLLEGE OF AGRICULTURE
AGRICULTURAL EXPERIMENT STATION AND EXTENSION
SERVICE IN AGRICULTURE AND HOME ECONOMICS

IN COOPERATION WITH THE BUREAU OF AGRICULTURAL
ENGINEERING, U. S. DEPARTMENT OF AGRICULTURE

PLOWING is one of the most important operations in good farming. It lays the foundation for a good seedbed, makes future seedbed and tillage operations easier, and furnishes a means of effective control against some destructive insects and plant diseases.

Most farmers can materially improve the work of their moldboard plows by keeping them in better working order, by adjusting them more carefully to soil and trash conditions, and, when purchasing new plows and attachments, by selecting those with certain advantages in construction and materials.

Not only better plowing, but adequate trash coverage for insect-pest control at little additional cost, can be accomplished by more thoro attention to the practices outlined herein.

CONTENTS

	PAGE
FACTORS IN GOOD PLOWING.....	4
NEED FOR GOOD TRASH COVERAGE.....	4
FIELD PRACTICES BEFORE PLOWING.....	7
CHOICE OF PLOWS AND PLOW PARTS.....	9
PLOW ATTACHMENTS AND THEIR ADJUSTMENT..	15
HITCHES AND WHEEL ADJUSTMENTS.....	24
SELECTING A NEW PLOW.....	35
INDEX.....	39

BETTER PLOWING

By THAYER CLEAVER and R. I. SHAWL¹

GOOD PLOWING is generally recognized as basic to good farming under soil and climatic conditions such as are found in Illinois. It is usually the first and most important step in preparing a seedbed. Its principal purpose is to improve the physical condition of the soil by pulverizing it, aerating it, and making it more retentive of moisture—thus providing more favorable conditions for seed germination and growth and for the development of the bacterial life and the chemical reactions that make soil nutrients available to plants.

There are other reasons for good plowing that are becoming of increasing importance in corn-belt farming. These are closely concerned with the proper coverage of trash (meaning by this all plant growth and manure that may be on the field), the complete and deep burial of which is necessary for the control of certain insect pests and weeds.

Still another reason for good plowing is that it makes future seedbed and tillage operations easier. By pulverizing the soil and burying the coarse trash it minimizes the operations necessary for the further preparation of the seedbed. In most soils trash should be covered at least 3 inches in the plowing operation, and preferably 4 inches, if it is not to interfere with succeeding operations. For the control of the European corn borer, the complete covering of all cornstalks and coarse trash must be given special attention.

Thoro pulverization and aeration of the soil, the complete, deep coverage of all surface trash, and the even distribution and thoro mixture of the trash with the soil in the bottom of the seedbed are thus the most important characteristics of good plowing. Pulverization, however, as is generally recognized, is not so necessary with fall plowing as with spring plowing, for the freezing and thawing that take place during the winter after fall plowing usually pulverize the soil sufficiently before crops are planted in the spring.

¹THAYER CLEAVER, Junior Agricultural Engineer, Bureau of Agricultural Engineering, U. S. Department of Agriculture, and R. I. SHAWL, Assistant Chief in Agricultural Engineering, University of Illinois.

FACTORS IN GOOD PLOWING

Good plowing can be accomplished only by giving due attention to certain factors of equipment and method: these are—

1. The use of correct field practices thruout the crop cycle. These include the proper cultivation and treatment of the growing crop, proper methods of harvesting, and proper treatment of the surface trash before plowing.
2. Plow bottoms that are suited to the soil.
3. Proper hitch with reference to plow and power.
4. Plow attachments suited to the work.
5. Correct adjustments of both plow and attachments.
6. Careful operation of both plow and tractor.

Poor or inadequate plowing is the price that is likely to be paid for failure to give proper attention to any one of the above factors, all of which are discussed in detail in this circular.

NEED FOR GOOD TRASH COVERAGE

Clean plowing—that is, the complete and deep coverage of all trash—is not only desirable but in some sections of the corn belt has become a necessity, as for example, where the European corn borer is a problem. No other single method of combating this pest has been found more effective than clean plowing; in fact clean plowing has proved the most practical large-scale method yet developed.

Other insect pests, such as the stalk borer, the corn field ant, and the corn root aphid, and some plant diseases such as corn ear rot, corn smut, wheat and barley rots, can also be partially controlled by clean plowing.

Deep Plowing Necessary for Good Trash Coverage

For the control of several of these insects and plant diseases, notably the European corn borer, all trash must not only be buried during plowing but must be *kept buried*. Under these circumstances it should be covered 5 or 6 inches by the plow; which means that the plow should turn the soil to a depth of 7 or 8 inches. There will then be little danger of its being brought to the surface during seedbed preparation and the planting and cultivating of the crop.

If at all possible, plowing should be done when the soil is moist enough to permit its being easily broken and when weather conditions are favorable. It is then less difficult to keep the plow running prop-

erly, less fuel and power are used, and less time and work are required to do a suitable job.

For best coverage a plowing depth of 7 to 8 inches is usually necessary for most soils where there is a large volume of trash to be turned under. The trash will then be buried far enough under the surface so that it need not be uncovered by later operations. If the plowing is very rough and broken, as it is in newly turned sod, a corrugated roller, packer, spike-tooth harrow, or plank drag may be used after plowing, so as to smooth the surface and fill up the holes before other implements are used.



FIG. 1.—GOOD AND POOR TRASH COVERAGE IN HEAVY CORNSTALKS WITH A TWO-BOTTOM, FOURTEEN-INCH PLOW

The excellent trash coverage to the left was made possible by the use of adequate trash-covering attachments. The poor trash coverage on the right resulted from the use of inadequate attachments. The same plow was used on both areas and run at the same depth.

Ninety-nine percent of all plant growth and other surface trash can be buried by a good, well-equipped plow carefully operated. Probably not more than 75 percent¹ of the trash is well buried by the average plow unless some of the plant growth is removed previous to plowing (Fig. 1). Ninety-five percent coverage of all trash is considered fair, 98 percent good, and 99.5 percent usually is considered excellent.

¹It is difficult to estimate the amount of trash left on the surface after plowing. The estimate of 75 percent is based upon tests and measurements made on a large number of farms over a period of years.

Plows Vary in Trash Covering Ability

Clean plowing can be done with some of the plows now in use if they are provided with suitable covering attachments and are properly adjusted. Plows that will cover trash satisfactorily must first meet certain requirements of horizontal and vertical clearance which are discussed on pages 35-37 under "Selecting a New Plow."

Both tractor and horse plows have their advantages and disadvantages as regards clean plowing. The operator on a horse plow can watch the plow more easily at all times; he is in a position to quickly dislodge any obstructions that tend to clog the plow and can more easily keep the plow operating uniformly. Tractor plows, on the other hand, usually have more clearance, which is of importance in handling trash and accommodating effective trash-covering attachments. They also operate at higher speeds than horse plows. All of these qualities are important aids to better coverage.

Speed of Plow a Factor in Good Coverage

The best speed for good coverage of trash depends on the soil and the type of bottom used, but there should be sufficient speed to turn furrow slices completely and leave a wide, open furrow, for in such a furrow trash is more easily disposed of and covered. The width of the open furrow varies with different types and sizes of bottoms. Where there are obstructions such as stones and tree roots, the speed of the plow should of course be moderated.

Care Needed Not to Turn Up Trash With Harrows

Harrows should be used with care on plowed soil where coverage of trash is necessary. The angle of the disk harrow should be watched, for if set too wide much buried trash will be turned up. The depth of harrowing—whether done with the spring-tooth, spike-tooth, or disk—should be carefully adjusted, for if operated at too great a depth these implements will uncover much buried trash.

Merits of Spring and Fall Plowing

Fall plowing has several advantages. Where soil erosion by water or by wind is not harmful, as much plowing should be done in the fall as is possible. Large volumes of trash, when plowed under in the fall, are less likely to interfere with capillary action in the soil than when plowed under in the spring. The likelihood of plowing being delayed by wet weather and rush of other work in the spring are also good reasons for fall plowing.

Of course soil and weather conditions and the harvesting of such crops as corn and soybeans, for example, frequently interfere with and sometimes prevent fall plowing; in which case there is no choice but to plow in the spring.

On soils that erode easily, the period between time of plowing and time of planting should be as short as possible. This means that spring plowing—not fall plowing—must be practiced on such soils.

Conditioning Plow Before Use Saves Plowing Time

Much can be done to the plow beforehand to prevent loss of time after plowing is begun. The entire plow, particularly the moving parts, should be examined and put in good condition; shares should be sharpened and pointed if necessary; and worn parts that are likely to cause trouble, such as the trip, wheels, landsides, colters, jointers, and the rear furrow wheel units, should be repaired or replaced. Neglect to put the plow in good condition beforehand may cost more, in time lost, than the repair and replacement of worn parts would have cost in the first place.

FIELD PRACTICES BEFORE PLOWING

Several practices other than the care, adjustment and operation of the plow and tractor are helpful in obtaining a clean job of plowing. Where a large volume of trash is to be buried, the field practices of the previous growing and harvesting season, as well as those immediately preceding plowing, are very important.

Excessive Ridging Should Be Avoided

In the first place excessive ridging of row crops during the last cultivation, especially such crops as field corn and broomcorn, should be avoided. If, however, the soil is rough or ridged and has a large volume of trash on the surface, the ridges should be leveled off and the trash put into condition for easier handling. Such treatment may consist of disking, cutting with a stalk cutter, raking and burning, or rolling with a flat or corrugated roller.

Burning Seldom Necessary

In some localities it is a common practice to rake and burn most of the trash that is difficult to plow under. Burning, however, should be avoided if any other method of disposal is practical, for decomposed trash is beneficial to the soil. Occasionally burning may be justified

when the volume of trash to be plowed under in the spring is so great as to be likely to interfere with capillary action, but this should not become a regular practice. Some kinds of trash, it is true, have relatively little value as fertilizers, but they nevertheless improve the physical condition of the soil, especially sand, clay, and clay loam types, and should usually be returned to the soil. The continual robbing of the soil of organic matter by the removal or burning of plant residues is an important factor in reducing its fertility.

Double-Disking an Excellent Practice

Practically all kinds of trash can be covered much more easily if given a good double-disking, so that the trash is broken up or cut and well mixed with the surface soil previous to plowing. Such treatment of trash is even more valuable if done during the preceding fall, or at least several weeks previous to plowing, for the heavy rains that will then intervene before plowing will help to settle the soil and thus cause it to hold small pieces of trash that otherwise will blow easily when disturbed. Not only is the trash more effectively covered in the plowing operation if disked beforehand, but a better seedbed is produced and the trash, being more thoroly mixed with the soil, it is generally conceded decomposes more readily.

Other Trash Treatments Previous to Plowing

A disk harrow which will cut thru the trash thoroly is the best machine to use where the soil is ridged, and it is usually more effective if run across or at an angle with the stalks and ridges than if run in the same direction.

A stalk cutter is sometimes more economical than a disk harrow for treating cornstalks, for the cutter requires less power for operation and can often be used during the winter and early spring when a disk harrow cannot be so used.

A pulverizing roller or a smooth roller is sometimes an aid when a disk harrow or stalk cutter cannot be used. The trash should be flattened out in the direction in which the plow will run. Merely dragging cornstalks down with a spike-tooth harrow, drag, or roller, however, while sometimes helpful, is not so beneficial as a good job of disking. A heavy pole or drag is of little or no value for treating trash but it does help a little to smooth the surface of the soil.

When corn is picked with a mechanical picker and no treatment is to be given the stalks before plowing, the plowing operation will be

made much easier if picking is done in lands of such size that the plow can always be worked in the same lands and in the same direction as the stalks are leaning. If the stalks are to be given some such treatment as disking before plowing, then the method of picking is immaterial.

Pasturing cornstalk fields reduces the amount of trash to be covered and also breaks up much of the trash and mixes it with the surface soil. From a mechanical standpoint there is no objection to this practice provided the livestock are not allowed to run in the field in the spring when the soil is in condition to pack.

Treatment of Back Furrows, Dead Furrows, and Headlands

Where clean plowing is desired and the field is not to be double-disked before plowing, the trash should be removed from the narrow strips where the back furrows, dead furrows, and headlands will be. This should be done before the weather is suitable for plowing, so that no time will be lost when plowing time arrives.

Whether plowing is to be done in lands or around the entire field, the headlands or corners should be marked with a well-turned furrow so that the plow can be lifted and lowered at the proper place; otherwise a ragged job will result. Where fences are more or less permanent, lands can be accurately measured and marked with a stake so that it will not be necessary to lay them off each season. Lands not accurately laid off usually become wedge-shaped, and cause trouble and waste of time when finishing a field.

CHOICE OF PLOW AND PLOW PARTS

If the best job of plowing is to be done, the plowing equipment must be selected with the greatest care. Different kinds of plows and plowing equipment have their advantages for different kinds of work and soils. These points are discussed here. Some of the more general points to consider in selecting a new plow are covered in a separate section, pages 35 to 37.

Types of Moldboard Plows

Tractor-drawn plows are available in three types—wheelless, two-wheel, and three-wheel. The wheelless plow is mounted on the tractor; that is, the tractor carries the weight of the plow when it is lifted from the ground. This plow has an advantage over other tractor plows in being usable in close quarters such as fence corners and small,

irregular fields. Most wheelless plows are light weight and do good work but they are not readily adaptable to different makes of tractors.

Some of the two-wheel plows have a fixed rear wheel which carries the landside pressure when plowing and makes it easier to move the plow when it is detached from the tractor. Because the hitch is semi-rigid, all the weight of the plow is carried on two wheels when the bottoms are lifted (Fig. 23, page 34, type D). Two-wheel plows are easier to maneuver than the three-wheel type when attached to the tractor.

Where large volumes of trash are to be handled, heavier plows will cut thru and handle trash better than lighter plows. A large number of tests have shown the three-wheel plow with flexible hitch to be most satisfactory where large acreages are to be plowed, especially in the heavier soils.

Some tractor-drawn plows have insufficient clearance beneath the beams and between the bottoms for handling large volumes of trash (Fig. 24). There is no necessity for purchasing one of this type since tractor plows are available in a variety of sizes and number of bottoms suitable for practically every farm tractor, soil condition, and most trash conditions.

Two-way plows are made for either tractor or horse power. Their use is usually limited to hillsides and conditions where back furrows and dead furrows must be avoided, as, for example, on irrigated farm land. The bottom of a two-way walking plow is attached to the beam in such a manner that it can be turned to throw furrows either to the right or the left. Two-way tractor plows and some two-way horse plows have both right and left turning bottoms which are used alternately to throw all furrow slices in one direction. Most of these are wheel-type plows, but there are a few wheelless types which are mounted directly on the tractor.

Horse-drawn plows, either walking or riding, for general farming, are available with the same types of bottoms. Walking plows are preferable for small acreages because of their relatively small cost and their convenience in plowing small and irregularly shaped fields. They are also available in hillside models with the moldboard reversible for throwing all furrows in the same direction. Walking plows, particularly the 14-inch size, are built for use with either two or three horses. Those built for three horses have the front of the beam farther to the left.

The horse-drawn riding plows are either sulkies (single bottom) or gangs (two or more bottoms); and they are either low lift (frameless) or high lift (framed). The low-lift or frameless plows are simpler

n construction, have fewer parts, and hence are of lighter weight. The high-lift or frame plows are easier to operate.

If properly adjusted there is little or no difference in draft between walking plows and the riding, or wheel, plows of the same size, for the advantage of carrying the load on wheels is offset by the disadvantage of the additional weight of the plow and the operator. One disadvantage of a wheel plow is that when improperly hitched, the difference in the quality of the plowing is not always noticeable but the draft is usually increased. If the hitch is not correct on a walking plow, an observant operator immediately is aware of it.

Plow Bottom Must Be Adapted to Soil and Work

A plow bottom suited to the soil and to the particular work to be done is the first and most important requirement for a good job of plowing. It should scour easily and cover trash completely and sufficiently deep; it should turn even furrow slices, pulverize the soil as much as desired, and leave it in good condition to make a seedbed. The metal of which it is constructed should be suited to the soil conditions under which it will be used.

Plow bottoms vary in shape and, to a certain degree, in size for different soil conditions and types of work, from the slow turning, long, low, sod bottom to the fast turning, shorter and higher moldboard stubble bottom. Between these two extremes is the general-purpose type of bottom, which resembles the stubble bottom more closely than the sod bottom. General-purpose bottoms are used for a wider range of conditions than sod or stubble types. They pulverize soil and cover trash better than the sod type, and have less draft than the stubble types. In general all other shapes of bottoms are variations of these three types. Since the general-purpose and stubble bottoms fit most soil conditions in the corn belt, and hence are more widely used, the information contained in this circular pertains particularly to these two types. If soil conditions vary widely on a farm it may pay the operator to have two sets of bottoms for his plow. Most manufacturers can furnish several types of bottoms for each plow which they make.

Plow Share Must Be Kept in Good Condition

The plow share, by cutting and lifting the furrow slice, does the first and most difficult of the work in the process of plowing. Approximately half the total plow draft is required for cutting the furrow slice loose from the soil and starting it up over the share. For this reason the importance of keeping the share in good condition cannot be overestimated.

Suction requirements of the share and landside for walking and wheel plows are shown in Figs. 2 and 3. A walking plow share differs from other plow shares by having what is known as wing bearing (Fig. 3). The wing bearing is the flat portion at the underside and tip of the wing, and varies from $\frac{3}{4}$ inch for 12-inch bottoms to $1\frac{1}{2}$ inches for 16-inch bottoms, measured directly toward the landside from the tip of the wing. The wing bearing steadies the outside corner of the bottom; if too narrow it will cause this corner to run too deep, or if too wide it will cause it to run too shallow. The correct amount of wing bearing varies for different soil conditions and can best be de-

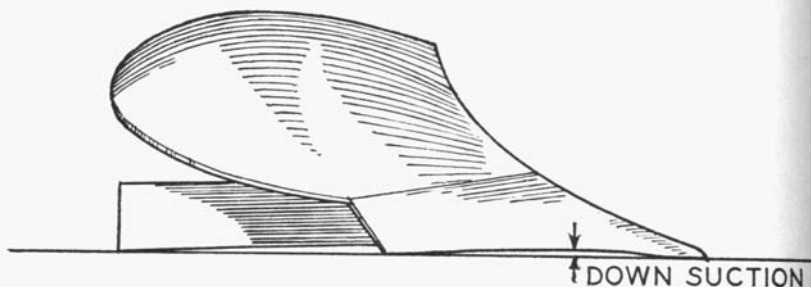

FIG. 2.—DOWN SUCTION OF PLOW SHARE

Down suction should be sufficient to permit the plow to penetrate and maintain a uniform depth in the soil. It varies, with different types of plows, from $\frac{1}{8}$ inch to $\frac{3}{8}$ inch.

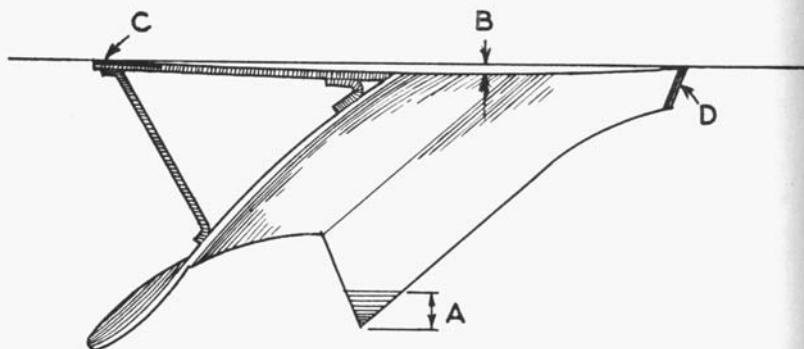

FIG. 3.—WING BEARING AND LAND SUCTION

On 12-inch to 16-inch walking-plow bottoms, wing bearing (A) varies from $\frac{3}{4}$ inch to $1\frac{1}{2}$ inches. Landside suction (B), which is approximately $\frac{3}{16}$ inch, is necessary for the bottom to maintain a uniform width of furrow slice. A walking plow in working position rests on the wing (A), the heel of the landside (C), and the point of the share (D). Landside suction is measured by placing a straightedge along the landside to the share point.

terminated by actual use of the plow in the field. Wing bearing is not needed in most wheel plows because the wheels hold the plow bottom in a normal level position. Down or share suction also varies for different soil conditions; more is needed for dry soil than for the same soil when moist.

Plow shares must be kept pointed, properly sharpened, and have the right amount of down suction and land suction or they will not do good work. When shares become dull and do not keep the proper depth, there is a tendency on the part of the plowman to hitch higher in order to make the plow keep its depth. This is not a good practice; it makes the plow "nose" down and wears the lower side of the point rapidly. It also causes the bottom to do rougher, less even work, and increases the draft (Fig. 20, page 31).

Choice of Metal for Plow Bottoms

Plow bottoms are available in soft-center steel, crucible steel, and chilled cast iron.

Soft-center steel is a special type of steel used in the construction of plow shares and moldboards. A cross-section of such steel is shown in Fig. 4. The center layer is soft steel and the top and bottom layers are high-carbon steel. Another type of soft-center steel, known as off-center soft-center steel, is now being manufactured in which the high-carbon steel is much thicker on the wearing side of the

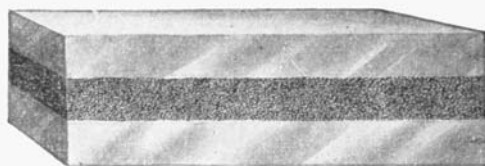

FIG. 4.—CROSS-SECTION OF SOFT-CENTER STEEL USED FOR SOME PLOW BOTTOMS

The high-carbon surface takes on a very high polish, which is necessary for scouring in some soils. The soft, low-carbon center layer gives protection against breakage from plowing strains and shocks. The high-carbon back layer reduces the tendency to warp while the moldboards are being shaped.

plow bottom than it is on the back. The purpose of this thick front layer is to give longer wear. It is a good wear-resistant material and at the same time is tough enough to withstand unusual shocks and heavy loads. Soft-center shares are sharpened by heating and forging. Sharpening and tempering should be done preferably by one who is experienced with such work. Exchange service is maintained by some

manufacturers whereby a dull share may be exchanged for a sharp one for a nominal sum.

Crucible steel bottoms are used where scouring is not difficult, but they are not suitable for use in sandy or gravelly soils because they wear too rapidly. Crucible steel is made by removing most of

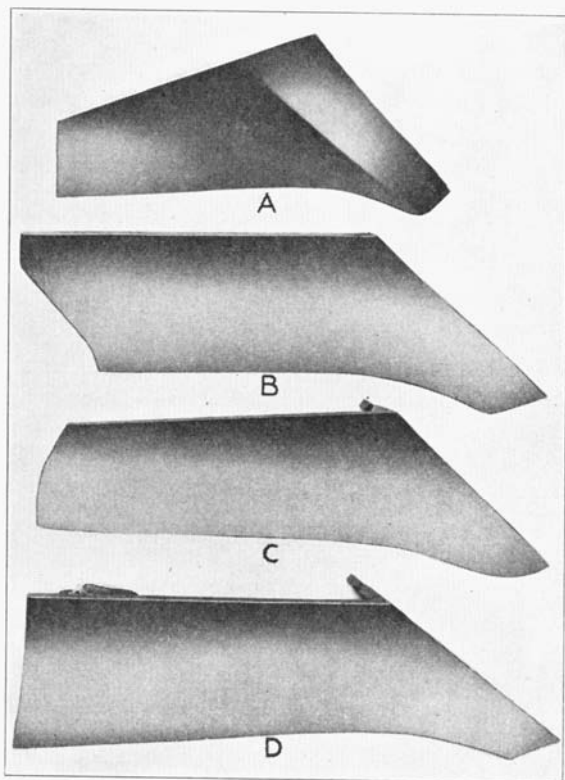

FIG. 5.—SPECIAL PLOW SHARES FOR UNUSUAL CONDITIONS

A. Chilled cast-iron share for a chilled cast-iron plow bottom. Used in stony, gravelly soils.

B. Stony ground share for use on a regular plow bottom. Has no wing bearing.

C. Solid steel blackland share for use in blackland soils.

D. Alfalfa share, with wide blade and extended wing to insure the cutting of all plant roots.

the impurities from cast iron. Its hardness varies in proportion to the amount of carbon which it carries, the low-carbon steel being softer and less brittle than the high-carbon steel.

Chilled cast iron shares can be obtained for most general-

purpose bottoms for use in dry, hard, or gravelly soils where scouring is not a problem. Chilled cast iron is a special type of iron made by pouring the hot metal into molds, the outside of which is very quickly cooled, thus producing a hard, tough, close-grained metal, which is used in the construction of plow moldboards and shares. Plow bottoms made from this material are of uniform texture and can be used until they wear thin enough to break but they should be sharpened occasionally by grinding. The process of chilling the iron next to the polished surface places the grain so that the dirt, in passing over the surface of the plow bottoms, rubs against the ends of the grain. Chilled cast iron bottoms are best for sandy and gravelly soil because they are very hard and wear-resistant.

Cast-iron shares can be sharpened only by grinding on the upper side. Since new shares are relatively cheap, they should be thrown away before they become too badly worn.

Other special shares are also available from most plow manufacturers for unusual conditions, such as very stony land and hard, dry ground where penetration is difficult, and for soil containing large tough plant roots such as alfalfa sod (Fig. 5).

PLOW ATTACHMENTS AND THEIR ADJUSTMENT

For practically all plowing one or more plow attachments are necessary if a good job is to be done. Where the crop has been removed and there is no other plant material, no attachment other than a colter is necessary; and occasionally good work can be done in light soils under such conditions without the aid of a colter, but such conditions are rare. Whenever there is a light to heavy amount of crop and weed residues or a heavy coating of strawy manure to be taken care of, suitable attachments are very necessary. When plowing under heavy trash, good coverage is impossible without the aid of suitable attachments. Under such circumstances the attachments may determine the success or failure of the entire plowing operation.

Rolling Colters

Rolling colters cut thru surface trash and plant roots and thus aid in securing a clean, smooth furrow wall. They help the plow to cover trash, and they usually reduce the draft of the plow bottom. Knife colters are more satisfactory than rolling colters in stony ground and ground with heavy root growth, and they are used to some extent also in sod, especially on walking plows. Only rolling colters will be considered here since they are superior to knife colters for all conditions except those mentioned above.

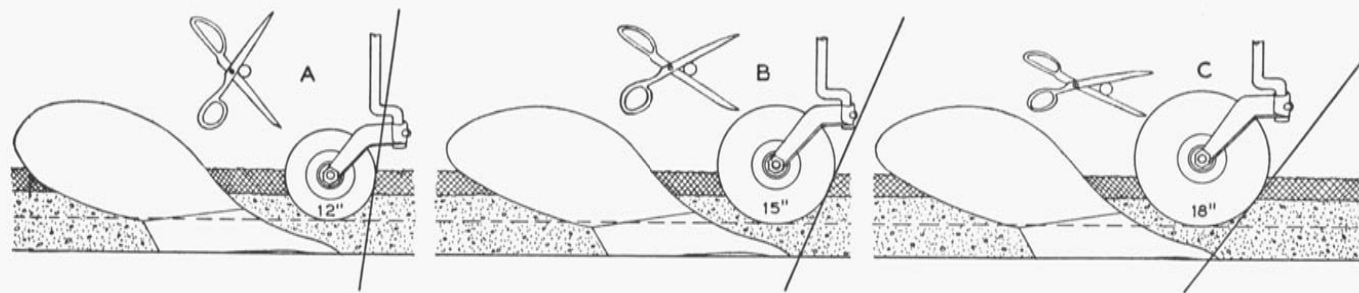

FIG. 6.—THE EIGHTEEN-INCH COLTER IS BEST FOR CUTTING TRASH

- A. A badly worn 12-inch colter which is unsatisfactory for any plowing except possibly sod.
- B. A 15-inch colter which is satisfactory for small volumes of light trash.
- C. An 18-inch colter with sufficient diameter to mount and cut practically all kinds of trash. The 18-inch colter can also be set as deep as desired to form a good furrow wall.
- (The shears illustrate the comparative ease with which the different sized colters cut thru large volumes of trash.)

Where there is little or no surface trash but an abundance of plant roots, as in sod, colters as small as 14 inches in diameter may be satisfactory, but when they are worn down to a diameter of 12 inches they are practically worthless for cutting large volumes of trash. For surface trash and rough, ridged soil such as cornstalk rows with high ridges, the colters should be 17 or 18 inches in diameter. A 15-inch

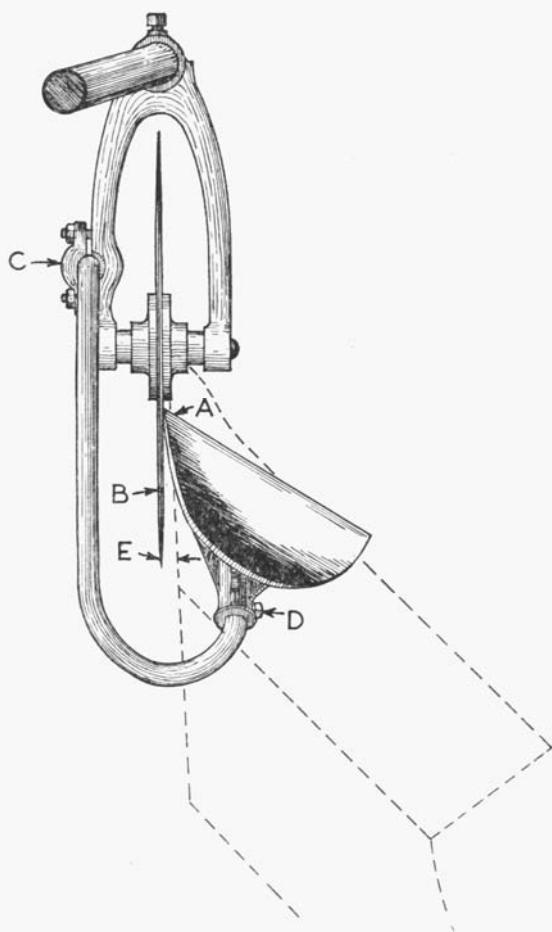

FIG. 7.—PROPER ADJUSTMENT OF ROLLING COLTER AND JOINTER

The point of the jointer (A) should bear only very lightly against the colter blade when in operation. Ample clearance must be provided between the jointer shin and colter blade (B) so as to prevent trash from clogging at this point. (C) Adjustment for raising and lowering the jointer. (C, D) Adjustment for providing more clearance at B. Colter blade (E) should be set from $\frac{1}{2}$ inch to 1 inch to the left of the landside. Position of the share and moldboard is shown by dotted lines.

colter may be satisfactory for less severe conditions where the soil surface is level; but if there is vertical clearance beneath the beams and axles to accommodate satisfactorily an 18-inch colter, it should always be used in preference to a smaller one for surface trash.

The 18-inch colters are also preferable to the smaller sizes because of their economy. An 18-inch colter will wear more than twice as long as a 15-inch colter before becoming too small for use, yet the 18-inch colter costs not quite 50 percent more than the 15-inch colter. The 18-inch colter also does much better work and does it easier, especially when cutting thru trash, because it can be set sufficiently deep to form a good furrow wall and at the same time will cut thru trash heavy enough to cause clogging with a smaller colter (Fig. 6). Colters with roller bearings will last much longer and keep their alinement better than those with the common types of bearings.

Directions for adjustment. For best results, set the colter just deep enough to cut thru all trash and form a smooth furrow wall. Set the hub approximately over the point of the share, with the blade placed half an inch to one inch to the left of the landside for right-hand bottoms (Fig. 7). The blade must run vertical, and the bearings must be kept greased and properly adjusted. Sharpen the colter blade occasionally, especially for trash which is tough and difficult to cut. Sharpening is done best by filing, or by careful grinding provided the metal is kept cool in the process.

If colters are not kept properly adjusted and in good condition, the plow may not respond properly to hitch adjustments and clogging may occur. Colters should be set shallow in hard soil and deeper in loose soil. For loose, mellow soils the colter hub may be set ahead of the share point, but in dry, hard ground the hub should be just over, or 1 to 2 inches back of, the point. If the shank or yoke becomes bent so the blade does not run vertical, the bent parts should be straightened or replaced unless shims placed under the colter clamp are sufficient to bring the blade to a vertical position. If the plow bottoms fail to scour, setting the colter a little more to the land and thereby forcing more soil against the bottom will sometimes increase the pressure against the moldboards sufficiently to overcome this trouble.

Extra Colter Sometimes Useful

An extra colter can sometimes be used very effectively on multiple-bottom tractor plows to eliminate the clogging of trash between bottoms when it occurs consistently (Fig. 8). The extra colter makes an additional cut thru all the trash about midway of the furrow slice

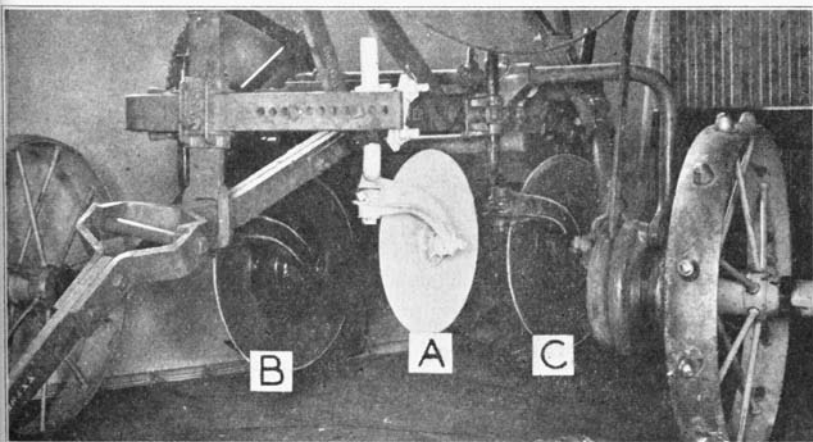

FIG. 8.—EXTRA COLTER FOR CUTTING TRASH

The extra colter (A) should be set approximately midway from front to rear and from right to left between the two regular colters (B and C). This extra colter helps to cut heavy trash so that it passes more readily thru the plow.

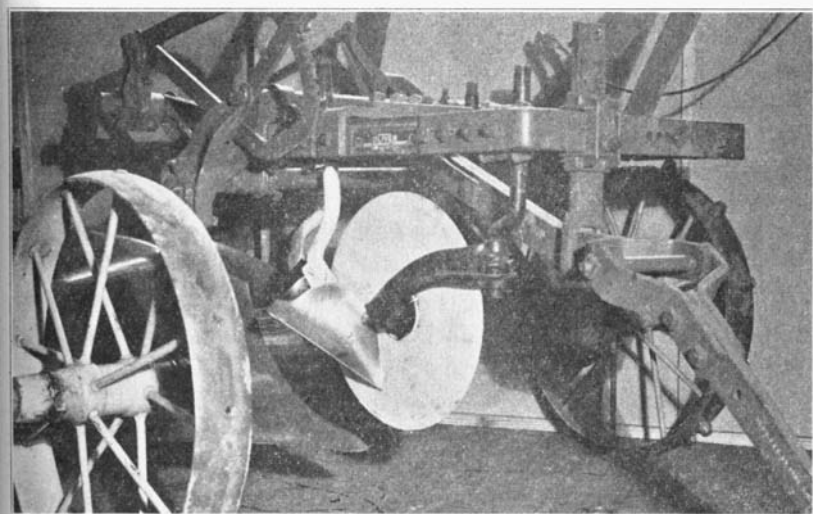

FIG. 9.—INDEPENDENT JOINTER AND COLTER

This jointer is attached rigidly to the beam with a clamp which provides adjustment both vertically and laterally. The colter is free to swing independently of the jointer.

and thereby prevents the trash from bridging across between plow bottoms.

The extra colter should be set to run approximately halfway between the regular colters and sufficiently deep to cut thru all trash. Sometimes the shank can be clamped to the front of the frame more easily than to the beam. It is best to use an 18-inch colter if the plow will accommodate it, because smaller blades cannot work as effectively as the larger ones in large volumes of trash. The use of an extra colter has been found to be especially satisfactory in preventing clogging troubles when plowing under large volumes of trash such as field corn and broomcorn stalks.

Moldboard Jointer

The moldboard jointer is a miniature plow bottom. Its purpose is to cut a small furrow from the top edge of the furrow slice next to the colter and roll this small furrow slice and the trash into the bottom of the furrow before the rising furrow slice crumbles and falls on it. The jointer is a great aid in covering trash, since without it trash protrudes between the turned furrow slices.

The moldboard jointer may be mounted directly on the beam with an independent shank and clamp, or may be used in combination with the colter by clamping the shank to the colter yoke (Figs. 7, 9). Both types of jointer mountings are available, and both do very satisfactory work if properly constructed and adjusted. The independent type is more rigid and can be used under some adverse conditions where the combination type does not work as well. Jointers cannot be used successfully with some plows where there is surface trash, because there is not enough clearance between the bottoms and under the beams and axles for the passage of the trash (Fig. 24, page 36).

Directions for adjustment. For most conditions, set the jointer to run an average depth of $2\frac{1}{2}$ inches. In rough ground the depth will vary considerably but it is best to set the jointer blade deep enough so that the point is always in the soil, otherwise it will catch trash and cause clogging. There should be ample clearance back of the jointer point between the jointer shin and the colter (Fig. 7). The jointer blade must never touch the colter blade anywhere except very lightly at the point when in operation. When the point becomes worn, turn the blade on the shank toward the colter. Since very hard, dry soils will press the jointer point more firmly against the colter blade, more clearance at the point will be necessary for such soils than for the lighter soils. If it is not possible to set the jointer with ample clearance

back of the point between the shin and the colter blade, then grind the shin off to increase the clearance. Most jointers have an adjustment for tilting them forward and backward and for turning.

Sometimes a jointer will throw trash and soil against the next forward bottom and thereby cause the bottom to clog with trash. If there is ample adjustment for tilting and turning the jointer and jointer blade, make this adjustment so that the trash will be thrown farther to the rear into the bottom of the furrow and immediately behind the next forward bottom. This adjustment for throwing the trash farther to the rear will frequently permit a jointer blade to scour which has been scouring poorly or not at all.

Disk Jointer

Different types of disk jointers are on the market, but none of them have proved very satisfactory for large volumes of trash. However, one developed by the Bureau of Agricultural Engineering, U. S. Department of Agriculture, has proved very satisfactory in a variety of soil and heavy trash conditions. A patent on this disk jointer has been secured recently and assigned to the Secretary of Agriculture as a public patent. It is expected that this attachment will be available soon from one or more manufacturers. Disk jointers are intended to replace both rolling colters and moldboard jointers.

To avoid excessive wear, disk jointers should have good, dirt-proof roller bearings, for their bearing pressures are greater than those of rolling colters. Also careful adjustment is necessary if they are to do good work. Disk jointers do not move trash and soil as far to the right as a moldboard jointer does, and for this reason can sometimes be used successfully with plows that have limited clearance since the trash is not thrown against the next bottom of gang plows or against the beams and axles. The disk jointer is not quite so effective when used alone for covering trash as is an 18-inch rolling colter and good moldboard jointer, but it can be used successfully under some conditions, such as when moldboard jointers cause trash clogs or when they will not scour.

Disk jointers should be set with the center of the disk approximately over the share point and just far enough to land to form a good furrow wall and deep enough to cut thru all trash. In firm soil a depth of 3 to 5 inches is usually sufficient to cut thru the trash. The blade should be at least 16 inches in diameter for effective work in trash, and 18 inches is much better if there is sufficient clearance under the beams and axles to accommodate it. The advantages of an 18-

inch over a 16-inch blade are the same as for the 18-inch rolling colters (see page 18). If the disks are set in a fixed position and at too great an angle, they may force the plow toward the unplowed land.

Other Trash-Covering Attachments

Covering wires are perhaps the cheapest of all trash-covering attachments, and are a great aid to any plow when trash is to be covered. Their attachment and adjustment are relatively simple, yet proper care in their use will greatly increase their effectiveness.

A covering wire should be 10 to 12 feet long, not smaller than No. 9 gage, and preferably No. 7 because the latter is stiffer, lasts longer, does not kink easily, and allows trash to slide along it more easily. Two wires should be used on single-bottom plows and on the front bottom of gang plows. Usually one wire is sufficient on the other bottoms of gang plows. One wire should be attached approximately at the front end and lower side of the colter yoke (Fig. 10). The second wire for the front bottom of the plow is usually placed on the front furrow-wheel axle, altho this is not always the best place. Sometimes it is better to attach it to a simple strap iron clamp by

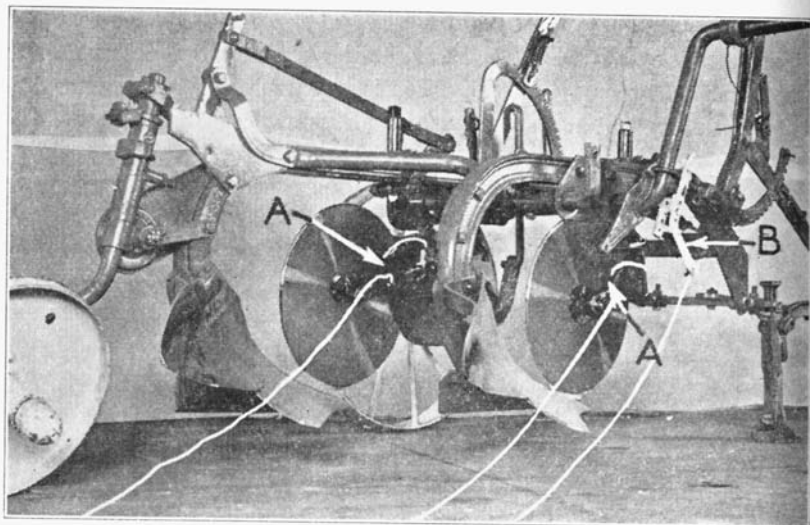

FIG. 10.—ATTACHMENT OF TRASH-COVERING WIRES TO GANG PLOW

One wire is attached to the front end of the colter yoke (A) on each bottom. The wire is given one turn around the colter yoke and fastened at a convenient point on the colter shank, such as the set screw or cotter key eye. A second wire on the front bottom is best attached by means of a simple iron clamp on the beam (B).

bending an eye in the end of the wire and bolting it rigidly to the lower end of the clamp. The clamp can then be moved or bent to the right or left until it is in the most effective position (Fig. 10).

It is important that covering wires be attached rigidly and securely, otherwise they are more likely to swing and catch in the wheels or get under the plow bottoms when the plow is lifted. Heavy, stiff wires, when attached rigidly, will cause little or no trouble. Backing the plow should be avoided as much as possible, since the wires may kink, tangle, drag trash, or break.

Chains can also be used satisfactorily on walking plows, especially when the plant growth is firmly attached to the soil. A 6- or

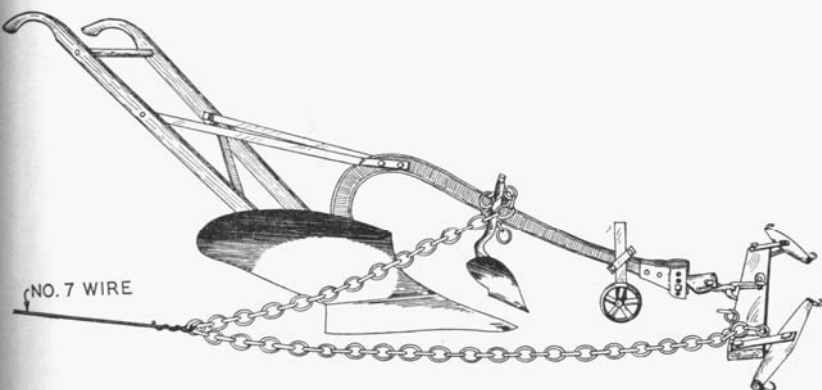

FIG. 11.—TRASH-COVERING CHAIN ON A WALKING PLOW

A 6-foot length of No. 7 wire attached to the chain loop as shown, and allowed to drag under the furrow slice, aids the chain in covering trash.

7-foot length of No. 7, 8, or 9 gage wire fastened to the chain loop will aid further in rolling trash into the bottom of the furrow (Fig. 11).

Weed hooks—or weed rods as they are sometimes called—are helpful where the plant growth is small and attached to the ground, but they are not very helpful in covering large volumes of loose trash. Flat springs and rods, shaped like sled runners and known as broom-corn springs and trash guards, respectively, are sometimes used to make trash feed under rolling colters.

A **solid front furrow wheel** on the plow is superior to an open wheel, especially in windy weather, as it prevents trash from being flipped onto the plowed ground. If a solid front furrow wheel or a shield for the open wheel is not obtainable from the manufacturer, a

circular piece of sheet metal can be cut and fitted inside the rim of the front wheel, as shown in Fig. 12.

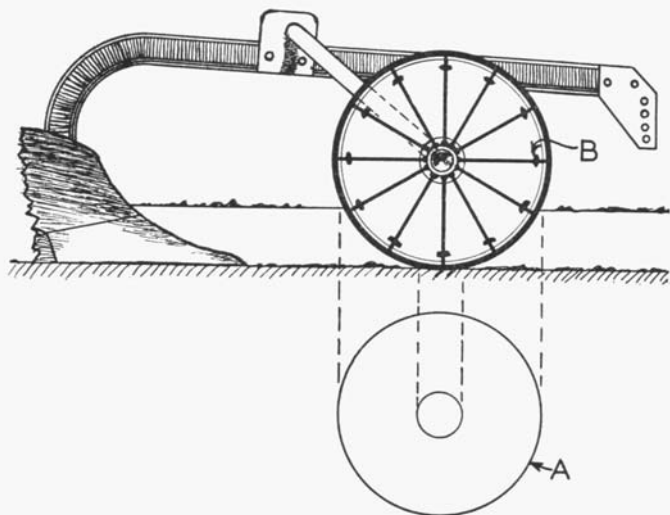

FIG. 12.—FRONT FURROW WHEEL SHIELD PREVENTS WHEEL FROM FLIPPING TRASH TO PLOWED GROUND

To make a shield like the above, cut a circular piece of sheet metal (A) with a diameter $\frac{1}{2}$ inch less than the rim of the wheel and with a hole at the center just large enough to clear the hub of the wheel when the shield is in place. Then remove the wheel from the plow and insert the shield under the rim of the wheel. The shield can be secured by punching holes in it and wiring it rigidly to the spokes of the wheel with No. 12 wire, as shown at B.

HITCHES AND WHEEL ADJUSTMENTS

The behavior of the plow is the best guide to the good plowman when adjustments should be made. Soil and field conditions vary so widely that frequent adjustments are often necessary in a single field. The type and condition of the soil, the amount of soil moisture, and the condition, amount, and kind of surface trash are variables which necessitate frequent adjustments if the plow is to do its best work.

The hitch adjustment is the most important of all adjustments. If the hitch is wrong, side draft is usually increased, and excessive wear on the plow, especially on the shares and landsides, poor pulverization and coverage, and wasted power are likely to result.

Whether on a walking plow, riding plow, or tractor plow, the hitch should be so set that the plow runs level from front to rear at the

desired depth and width of cut without much guidance from the wheels or, in the case of a walking plow, the handles.

The center of resistance of a plow bottom is not a fixed point. Its location is, however, usually near a point on the line where the share and moldboard meet and 2 to 4½ inches from the landside, depending upon the width of the bottom. This location may be used as a guide in adjusting both the plow and the tractor hitch. The center

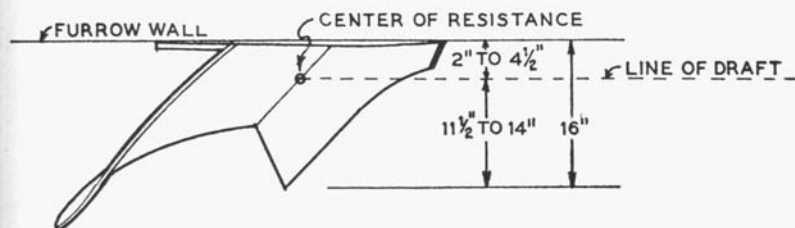

FIG. 13.—CENTER OF RESISTANCE ON A PLOW BOTTOM

The center of resistance is estimated to be 2 to 4½ inches from the landside at or near the intersection of the share and moldboard. When plowing heavy, tough soils or sods, the center of resistance shifts forward toward the cutting edge of the share.

of resistance may shift considerably under varying soil and trash conditions from a point almost directly under the beams to nearly the center of the cut (Fig. 13). The center of resistance of a multiple-bottom plow is half way between that of the front and rear bottoms of the plow (Fig. 21, page 32).

Hitch Adjustments for a Horse Plow

The correct *line of hitch* for a horse plow is a straight line extending from the center of resistance of the plow thru the point of hitch on the plow bridle to the point of attachment at the source of power (Figs. 14 and 16).

The power from the horse is applied at the point where the traces are attached to the hames. If the cross clevis is above or below the straight line of hitch, the plow will tend to run too deep or too shallow. When two horses are used, the correct *line of pull* is located halfway between the ends of the evener to which the horses are hitched. To get the most effective working conditions, the correct *line of draft* of the plow should coincide with the actual *line of pull* of the horses. In other words, the *line of pull* and the *line of draft* should coincide.

Side draft occurs when the power is attached to the plow at either side of the line of draft. Such side draft is more noticeable if the vertical hitch is too high on the plow. The correct line of draft should

also extend straight forward or slightly to the right from the center of resistance for most plows, but a compromise usually must be made between the line of draft and the line of pull.

If three or more horses are hitched abreast on a one- or two-bottom plow, the line of pull and line of draft will not coincide and excessive

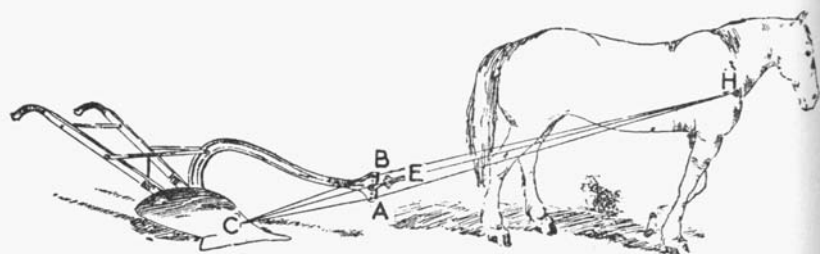

FIG. 14.—LINE OF VERTICAL HITCH FOR A HORSE-DRAWN PLOW

The correct line of hitch for a horse-drawn plow is shown by the line C-E-H. It extends from the horse's shoulders back to the point C, which represents the center of resistance of the plow bottom. The point E, where this straight line cuts the vertical clevis of the plow, is the proper point at which to attach the hitch to the plow. If the hitch is attached at A, the front of the bottom will be lifted up and will cause shallow plowing. If attached at B, the bottom will nose or run too deep. For line of horizontal hitch, see Fig. 16.

side draft will result. The best way to reduce side draft is to hitch the horses in tandem. Tandem hitches for four, five, and six horses are shown in Fig. 15. When more than three horses are hitched abreast, they crowd each other and do not work comfortably. Horses work most comfortably when the traces are moderately long. A short hitch does not save power, as is sometimes believed, but it raises the front end of the plow so that the plow tends to run shallower unless the cross clevis is raised to the line of draft.

The height of the cross clevis, the weight of the eveners, the length of the traces, and the height of the team all affect the depth at which a horse plow will run. The number of horses hitched abreast, the length of the eveners, and the way the horses are reined together affect the operation of a plow and must be considered when attaching the evener to the plow. If the share of the walking plow is kept in good condition, the plow responds more rapidly to changes in adjustment. The hitch of walking plows is adjustable for depth by moving the cross clevis up or down on the plow bridle, and adjustable for

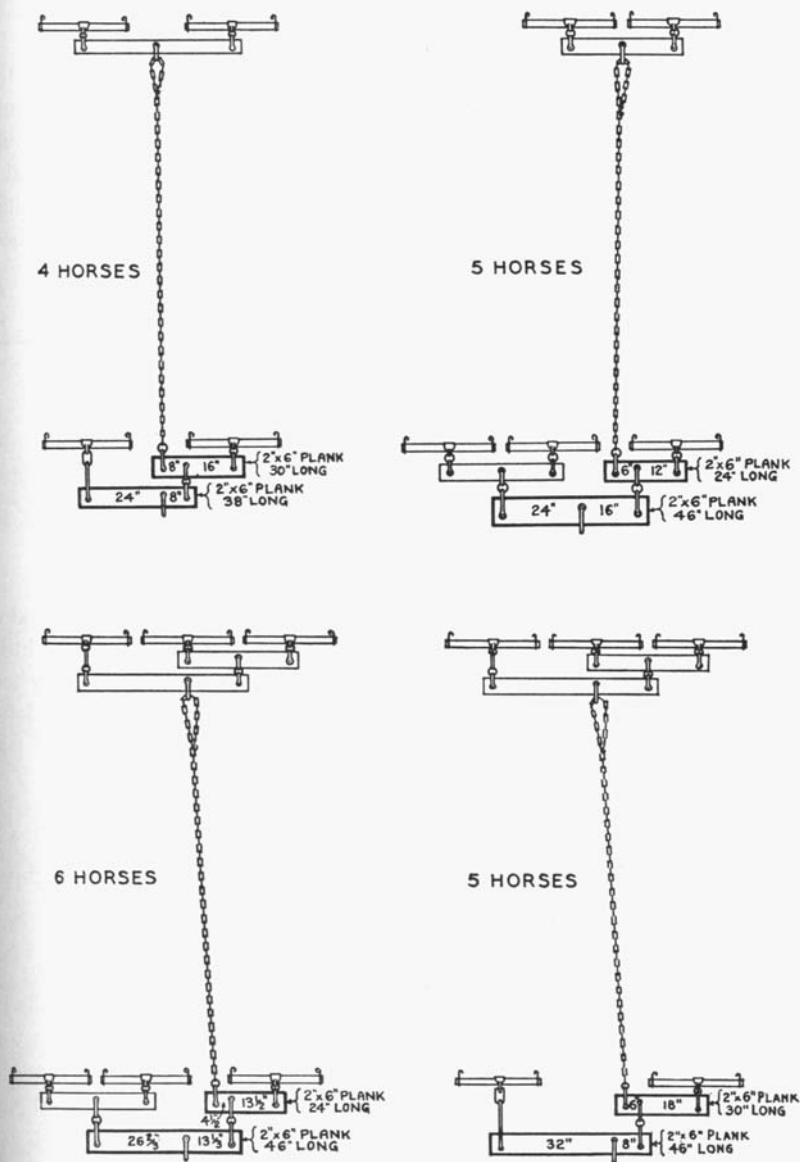

FIG. 15.—FOUR-, FIVE-, AND SIX-HORSE TANDEM HITCHES

Talkington eveners for four different combinations of horses are shown above. These are good for a two-bottom gang. The five-horse evenner is changed to a six-horse by boring additional holes. Wagon doubletrees can be used for the front eveners on the four-horse hitch, but on the five- and six-horse hitches it is best to use the shorter plow eveners.

width of cut by moving the twisted clevis on the cross clevis toward or away from the open furrow.

When the hitch of a sulky or gang plow is properly adjusted, the front furrow wheel, the rear furrow wheel, and the land wheel should carry equal amounts of the load. The vertical hitch adjustment should be set so that the wheels need only to steady the plow and hold it at a uniform depth especially where the soil is loose or wet. If the hitch is set at the proper height, it can be tested by unlatching the land wheel

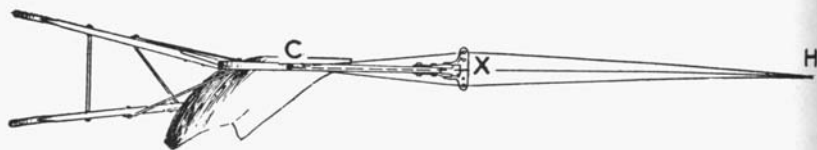

FIG. 16.—LINE OF HORIZONTAL HITCH FOR A HORSE-DRAWN PLOW

The point C, which is estimated to be the center of resistance of the plow bottom, is located about 3 inches up from the bottom of the landside and 2 to 4½ inches from the shin. Correct line of hitch is shown by line C-X-H. See Fig. 14 for line of vertical hitch.

lever for a short distance. Then if the hitch is correct, the operator can hold the plow at the desired depth by means of the lever with little or no effort. If the hitch is too high, the front wheels will carry too much of the load and the plow will tend to run too deep when the land wheel lever is unlatched. If the hitch is too low, the plow will not run deep enough.

If a horse plow is to be pulled straight ahead with the least draft, the clevis should be shifted to the right or left, as the case may be, until it is in the correct line of draft of the plow. That is, the three points C-X-H shown in Fig. 16 should make a straight line.

Wheel Adjustments for Horse Plows

The wheel adjustment on wheel plows should be correctly made if the plow is to run properly, whether it be a horse plow or tractor plow. Wheels properly adjusted hold the plow steady, help to overcome side draft and lighten the load on the horses. Proper manipulation of the levers holds the plow level and helps to make the furrow crowns more uniform in rough, uneven soil. The front furrow wheel of most horse plows may be moved in or out to secure the proper width of cut of the front bottom (Fig. 17). This wheel should be set to run just enough toward the unplowed land to keep it in the corner of the furrow.

Rear furrow wheels may be adjustable or nonadjustable. The non-

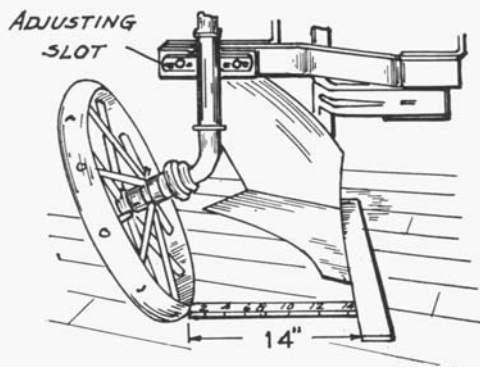

FIG. 17.—MEASURING WIDTH OF CUT OF FRONT BOTTOM

To adjust width of cut on horse-drawn plows, the wheel is moved in or out on its axle or, where the front wheel standard is joined to the frame, by moving the casting to the left or right.

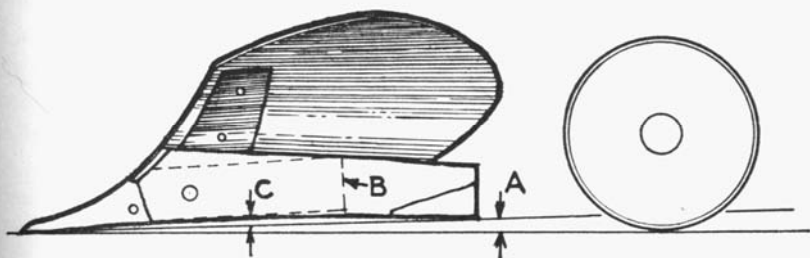

FIG. 18.—ADJUSTING THE REAR FURROW WHEEL FOR DOWN SUCTION OR PENETRATION

The clearance of the heel of the landside on wheel plows varies but should be approximately $\frac{1}{2}$ inch (A). The dotted line at B shows the position and length of the landside for all but the rear bottom on most gang plows. The down suction of a walking plow should be from $\frac{1}{8}$ to $\frac{3}{8}$ inch (C) (see also Fig. 2). This suction can be determined by placing a straightedge under the share from the point to the heel of the landside and measuring at the point of greatest clearance.

adjustable type is better known as a rolling landside. Either type of furrow wheel should be set slightly below and to the left of the landside so that it carries practically all the side and vertical pressure at the rear of the plow, and it should angle slightly away from the furrow wall (Fig. 18). When properly adjusted there should be room enough to slip the tips of the fingers under the heel of the landside of the rear plow bottom. Less clearance under the heel of the landside may be advisable in waxy soils if penetration is easy, while more clearance for hard, dry ground may be necessary where penetration is difficult.

Improper setting of the rear furrow wheel which permits the landside to press against the furrow wall often results in a badly worn landside, poorer quality of plowing, and failure of the plow to run straight forward.

Manufacturers' instruction books give the correct settings of each individual plow of both tractor and horse types.

Hitches for the Tractor Plow

Trouble due to improper hitching can seldom be entirely overcome by any other adjustment. The hitch is best adjusted by first lowering the plow to the desired depth of plowing by means of the adjusting levers. Then for lightest draft the hitch should be set as low as possible on the front of the beams with the tractor drawbar low enough to permit the plow to keep the desired depth in all parts of the field. This setting also pulls the plow bottoms in their normal and best working position and prevents nosing or reduces it to a minimum (Fig. 19). If better penetration is desired it is usually best to lower the tractor drawbar hitch rather than hitch higher on the plow, because a higher plow hitch may result in nosing (Fig. 20). If the plow runs too deep, the plow hitch should be lowered at the plow, then if further adjustment is necessary the tractor drawbar may be raised until all three plow wheels carry an equal amount of the load. If the drawbar is raised too high, the tractor may be difficult to steer. The hitch setting on the tractor and plow should be used first for obtaining the depth; the levers should be used only to adjust the plow depth to soil differences in the field and to level the plow.

Side draft on tractor plows is small if proper adjustments are made and if a standard-tread tractor is used. If a wide-tread tractor is used, the wheels should be set closer, if at all possible, for two-bottom plows, until the line of draft of the plow is directly behind the center hole of the drawbar or one hole to the right of the center when the plow and tractor are in their correct working position; otherwise the plow or tractor, or both, will receive too much side draft (Fig. 22). If the side draft is on the plow, the plow may run at an angle, causing undue wear and poor quality of plowing. If the side draft is thrown on the tractor, it will be more difficult to steer, will not run as straight, and will be subject to greater wear. If it is not possible to set the tractor wheels closer together so as to reduce side draft, the plow clevis may be set half way between the center hole of the tractor drawbar and the line of draft of the plow and an adjustment made for width of cut on the plow hitch (Fig. 22). If

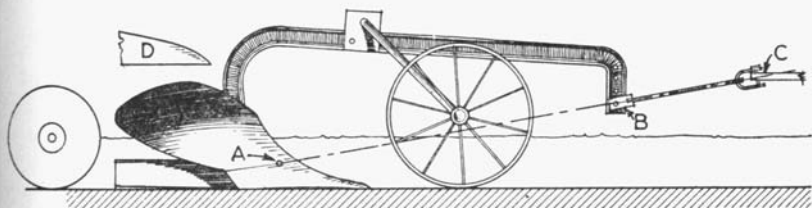

FIG. 19.—PROPER HITCH ADJUSTMENT FOR TRACTOR PLOW

The line of draft of a tractor plow, when in correct working position, is indicated by the straight line A-B-C, which starts from the center of resistance of the plow bottom (A), passes thru the point of vertical hitch on the plow (B) to the tractor bar at C. The normal wear of the share point when the hitch is correctly adjusted is shown at D. Compare this with the share point in Fig. 20, D.

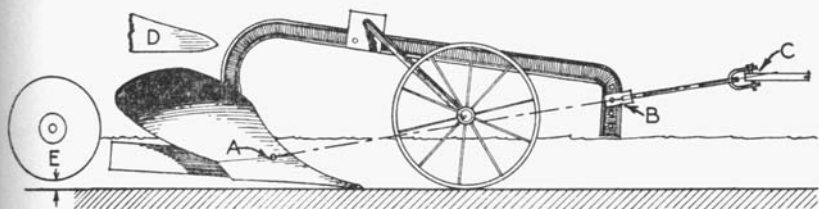

FIG. 20.—IMPROPER HITCHING OF A TRACTOR PLOW

When the vertical hitch is attached too high, as at B, the front of the beam is tilted down as shown. This tilts the plow bottom and causes what is known as nosing. Nosing reduces the load on the rear furrow wheel and results in excessive wear on the underside of the share point as shown at D, in poorly turned furrow slices, and increased clearance of the rear furrow wheel to the extent that it may be raised clear of the bottom of the furrow as at E.

side draft is too great on either the plow or tractor, lengthening the hitch will help to make it less noticeable. Adjustments for width of cut on tractor plows usually should be made on the plow hitch and not by shifting the tractor drawbar or the point of hitch on the drawbar. The front furrow wheel of a tractor plow must run clear of the furrow wall.

Different types of hitches for use on a tractor plow are shown in Fig. 23, page 34.

Wheel Adjustments on the Tractor Plow

The rear furrow wheel on the newer tractor plows is usually set to run straight ahead in the angle formed by the furrow wall and furrow sole (Figs. 18 and 21). In this position the rear furrow wheel carries most of the side thrust at the rear end of the plow and reduces

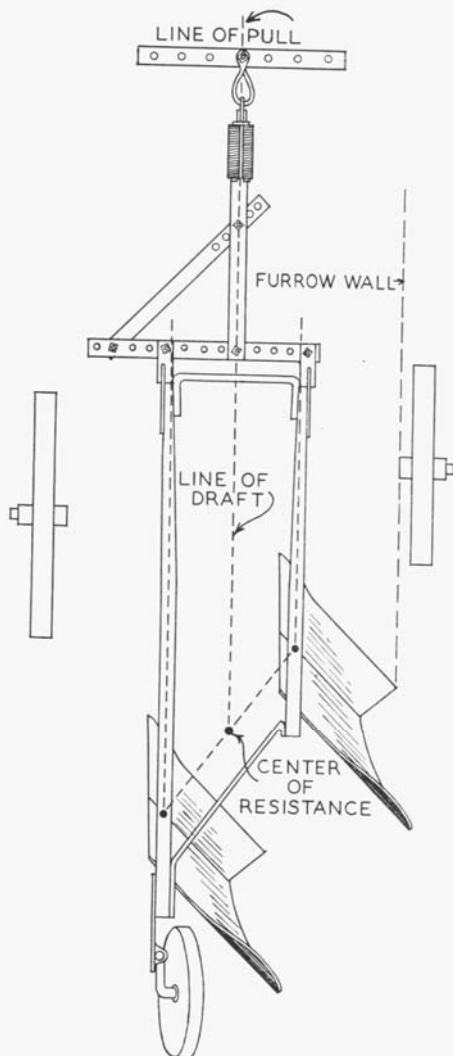

FIG. 21.—THE MOST SATISFACTORY HITCH WHEN TRACTOR DRIVE WHEELS HAVE EQUAL TRACTION

The above hitch reduces side draft to a minimum. The center of resistance on a two-bottom plow is about halfway between the two beams, as shown. The line of draft extending forward from this point (dotted line) should pass thru the plow clevis and the line of pull on the tractor at the drawbar. When a plow is properly hitched, the line of draft and the line of pull should coincide, but this condition is seldom realized. In tough, waxy soils or sod the center of resistance shifts forward and to the right toward the cutting edge of the share. For method of evening up side draft on a wide-tread tractor, see Fig. 22.

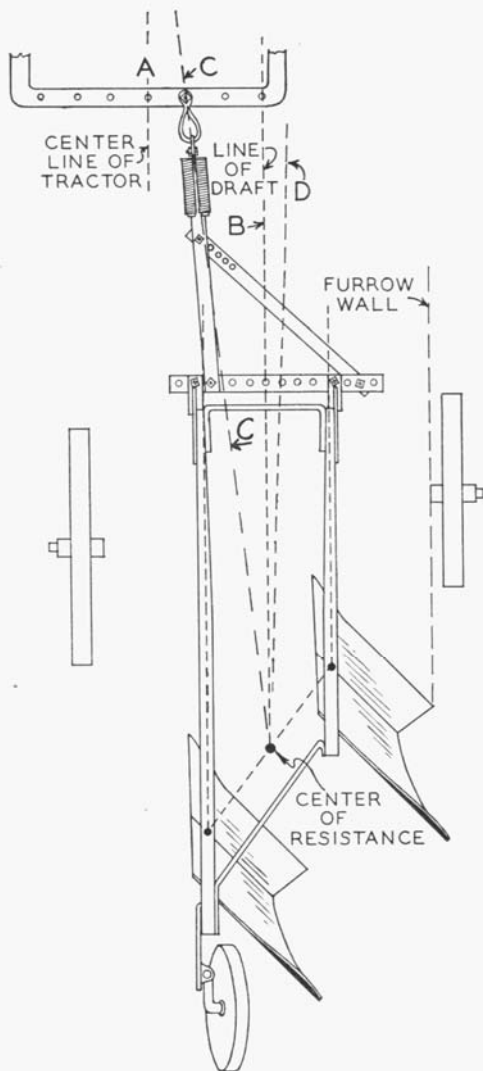

FIG. 22.—EVENING UP SIDE DRAFT ON A WIDE-TREAD TRACTOR

On wide-tread tractors the center of the drawbar is so far from the furrow wall that the plow cannot be attached as shown in Fig. 21. It is then desirable to set the hitch about midway between A and B, as shown above. Neither the plow nor the tractor is likely to work properly if all the side draft is shifted to one or the other. Hitching one hole to the right of the center hole on the drawbar will seldom cause noticeable side draft on the tractor. The line of pull of the tractor (A) will cause no side draft on the tractor if the drive wheels have equal traction. For minimum draft of the plow, the line of draft should be a little to the right of B, as shown by D, because the rear of the plow tends to move toward the unplowed land. If the line of draft is to the left of B, as shown by C, the draft increases.

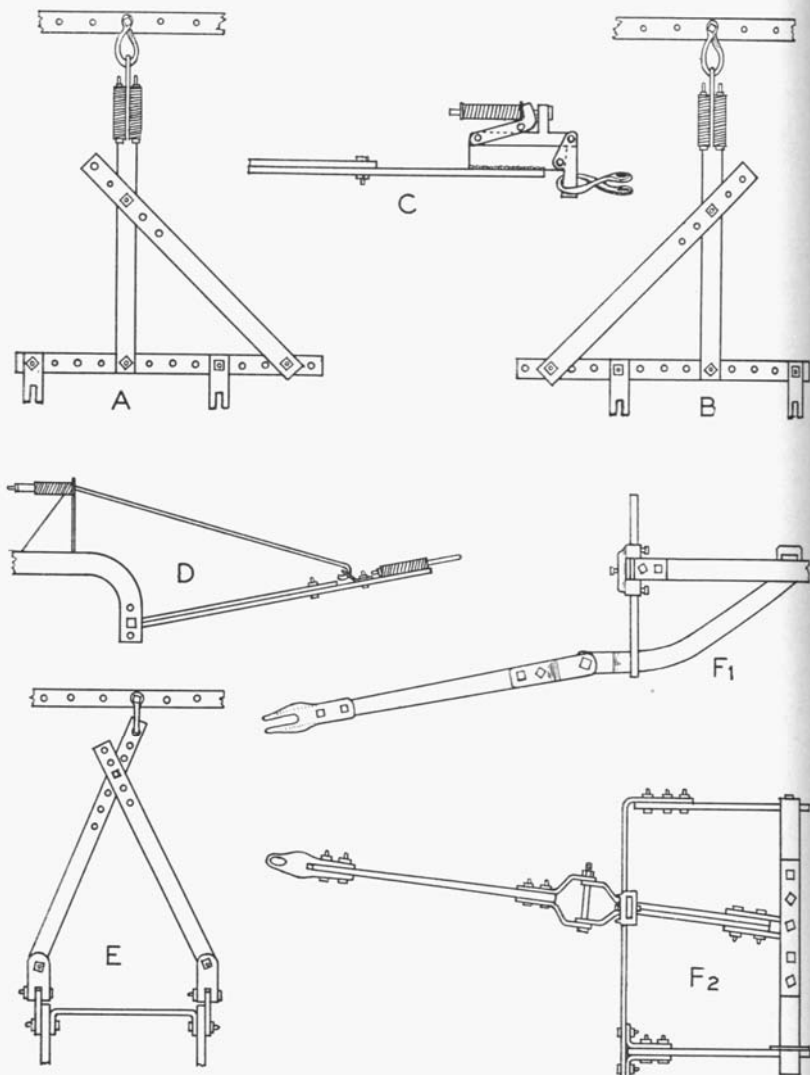

FIG. 23.—COMMON TYPES OF TRACTOR PLOW HITCHES NOW IN USE

A, B. Full-floating adjustable bar hitch, with draft bar straight ahead and the angling bar set at either the right or left side.

C. Recent type of overload spring release and method of attaching the plow to the tractor. Other overload releases are shown in A, B, D.

D. Semi-floating hitch used on two-wheel plows. A high lift of the plow is made possible by the angling bar at the top of the hitch.

E. Full-floating hitch, with limited provision for adjustment. A simple design with no overload release.

F1, F2. Full-floating angle-bar adjustable hitch showing side and top views. A wooden break-pin overload release is used.

All the above hitches have provision for vertical and lateral adjustments.

the wear on the landside to a minimum. The rear furrow wheel cannot be moved away from or closer to the furrow wall on most plows, but some tractor plows have an adjustment for turning the wheel so that it runs slightly toward the plowed land. This latter adjustment is necessary when side draft becomes excessive. Some tractor plows also have an adjustment on the rear furrow wheel unit for changing the amount of down suction. This adjustment usually is made with a set screw which raises or lowers the rear of the plow frame when the plow is in the ground. The link connecting the rear furrow wheel with the lifting levers should be slack when the plow is in the ground.

When properly adjusted, the heel of the landside should be about half an inch, or the thickness of the operator's finger tips, above the bottom of the furrow (Fig. 18). Tractor plows which do not have a rear furrow wheel have a heavy reinforcement on the heel of the landside to take care of wear and side thrust.

Light tractor plows will sometimes fail to do satisfactory work in dry, hard soil altho they are properly adjusted and in good shape for normal plowing conditions. For plowing in hard, dry soils, the addition of extra weight placed on the plow directly above the bottoms will help to make the plow run properly.

A safety hitch or overload release should be used at all times when plowing, especially where there are obstructions such as large stones, stumps, and tree roots. Break pins are fairly satisfactory where obstructions are few, but spring controlled overload releases are much better. The overload release should be so adjusted that it will release before the plow is damaged.

SELECTING A NEW PLOW

The selection of a new plow and its attachments is always an important problem. Clean plowing depends, of course, upon the operator and field conditions as well as on the plow, but the choice of a good plow is the first essential for clean plowing.

A plow should have certain definite characteristics if it is to do satisfactory work. The following points should be carefully considered when selecting a plow:

1. Strong and rigid construction
2. Ample clearance for the passage of trash and the accommodation of attachments
3. Plow bottoms of the proper size and suited to the soil, speed of plowing, and power available

4. Eighteen-inch colters and moldboard jointers if available
5. Provision for ample and easy adjustment of the hitch and attachments
6. Pressure lubrication for all moving parts

Strong, rigid construction of the plow frame, wheels, axles, lifting device, bearings, levers, plow bottoms, and hitch are extremely important in long life and dependable service. Increased speeds in plowing, due chiefly to the introduction of rubber tires for tractors, have put heavy strains on axles, wheels, bearings, and lifting devices, and strong construction in these parts will reduce field delays and costly repairs. Each plow bottom should be strongly braced and attached to the beam. The hitch must have an ample safety feature to protect the plow when obstructions are encountered. The plow levers should be easily operated while the plow is in use.

Ample clearance, both horizontally and vertically, for the passage of the largest volumes of trash likely to be encountered, and the accommodation of attachments for handling such trash, must be provided for in a plow if it is to do satisfactory work (Fig. 24). There

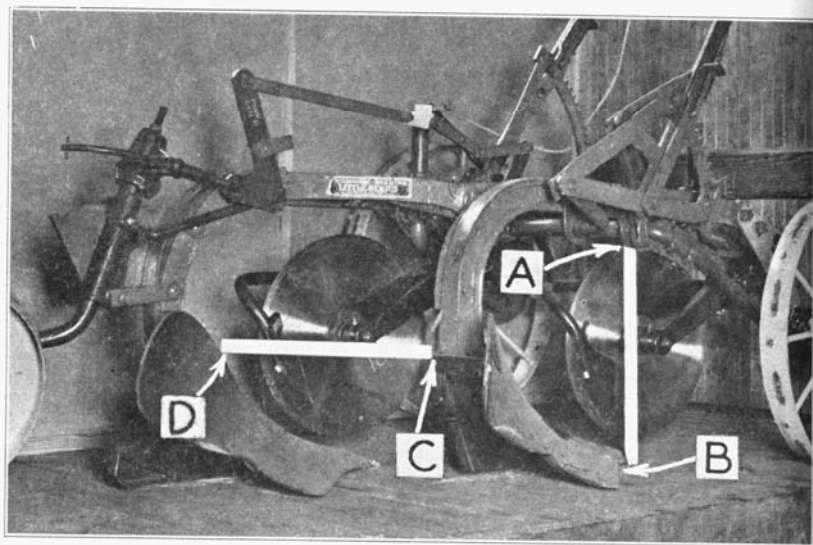

FIG. 24.—PLOW CLEARANCES FOR PASSAGE OF TRASH

Vertical clearance is measured from the lowest point under the beams (A) to the bottom of the share (B). Horizontal clearance is measured from the top of the shin (D) to the nearest point on the beam or bottom ahead (C), which is usually a brace. These clearances should be as large as possible to allow for the free passage of trash, and the vertical clearance should also be sufficient for mounting an 18-inch colter when the lower edge of the blade is 3 inches above the bottom of the furrow.

should be as much, or more, horizontal clearance between the front bottom and the front furrow wheel as there is between bottoms. Sufficient vertical clearance should be provided for all the bottoms under the beams and axles to easily accommodate 18-inch colters when they are set with the lower edge 3 inches above the bottom of the share.

Plows vary greatly in trash-covering ability, as shown repeatedly by a wide variety of field tests in different soils and over a period of several years.

Size and number of plow bottoms should be adapted to plowing conditions with the power available. This is especially true with tractor plows because the power of a tractor ordinarily cannot be changed. The implement manufacturer supplies the proper shape of plow bottom for each locality. For high-speed plowing some manufacturers have designed bottoms that will turn the soil properly at speeds above four miles an hour. The 16-inch and 18-inch plows are usually referred to as wide-bottom plows. Wide-bottom plows usually have much better clearance for covering trash than the smaller ones. In some soils the wide-bottom plows do not pulverize as well as the narrower bottoms, but this feature usually is not objectionable, especially for fall plowing, because freezing and thawing usually pulverize the soil sufficiently during the winter months. The wide-bottom plows also turn more uniform furrows in badly ridged soil which is not treated before plowing. Wide-bottom plows have a natural advantage over smaller plows because there are fewer furrow slices between which trash may protrude. So far as its effectiveness for clean plowing is concerned, it is not important whether the plow bottom is 14 inches wide or 18 inches, if the plow has ample clearance for handling large volumes of trash.

Large colters and jointers are extremely important in securing good trash coverage, and where it is possible to use them, colters of 18-inch diameter should be purchased. See page 18 for discussion of colters.

Provision for **ample and easy changes** in adjustment of the hitch and attachments is obviously necessary for satisfactory operation.

Pressure lubrication for all important moving parts of a plow is highly desirable if the plow is to be lubricated at the proper intervals. Pressure lubrication is most essential on plows operated at higher speeds. When complete pressure lubrication is not provided, pressure fittings can be installed in a short time at small cost.

OTHER INFORMATION ON FARM MACHINERY

College of Agriculture, University of Illinois, Urbana

Farm Machinery—Its Purchase, Care, Operation, and Adjustment. *Circ. 309.*

Reducing Grain Losses in Threshing. *Circ. 311.*

Combines in Illinois (1927). *Circ. 316.*

Big Teams on Illinois Farms. *Circ. 355.* Contains further information on hitches for big teams.

Tractor Repair and Maintenance. *Circ. 425.*

U. S. Department of Agriculture, Washington, D. C.

Plowing With Moldboard Plows. *Farmers Bul. 1690.*

Laying Out Fields for Tractor Plowing. *Farmers Bul. 1045.*

Other State Experiment Stations

Prolonging Plowshare Service. *Bul. 202, Agricultural Experiment Station, Moscow, Idaho.*

Life, Service, and Cost of Service of Farm Machinery. *Bul. 260, Agricultural Experiment Station, Ames, Iowa.*

The Use and Expense of Farm Implements. *Bul. 345, Agricultural Experiment Station, Lexington, Ky.*

Manufacturers of Farm Machinery

Some excellent pamphlets are issued by the various farm machinery manufacturers on the operation, care, and repair of plows. For particulars write direct to the companies or see their local dealers.

INDEX

- Bottoms—
 choice of metal for, 13-15
 number and size, 37
 types for corn belt, 11
- Broom corn springs, 23
- Burning trash, 7-8
- Chains for trash coverage, 23
- Clearance, 6, 36-37
- Colter, extra, 18-20
 rolling, 15-18, 37
- Deep plowing for trash coverage, 4-5
- Disk harrow—
 angle of, 6
 for cutting trash, 8
- Drag to flatten trash, 8
- Field practices before plowing, 7-9
- Front furrow wheel, solid, 23-24
- Furrows, treatment of back and dead, 9
- Good plowing—
 characteristics of, 3
 factors in, 4
 reasons for, 3
- Harrowing, depth of, 6
- Headlands, treatment of, 9
- Hitches and wheel adjustments, 24-35
- Horizontal hitch—
 for horse plows, 25-26, 28
 for tractor plows, 24-25, 30-34
- Jointer—
 disk, 21-22
 moldboard, 17, 19, 20-21
- Lands for corn picking and plowing, 9
- Landside, clearance of, 29, 35
- Landside adjustment—
 on horse plows, 25, 28, 29
 on tractor plows, 25, 29, 35
- Metals, choice of for bottoms, 13-15
- Moldboard plow, types of, 9-10
- Nosing, 30, 31
- Pasturing to reduce trash, 9
- Plow attachments and adjustments,
 15-24
- Plow—
 care of, 7, 13
 choice of, 6, 9-11
- Resistance, center of, 25, 32, 33
- Ridges, treatment of, 8, 9
- Ridging of row crops, avoid, 7
- Roller for treating trash, 8
- Safety hitch, overload release, 35
- Selecting a new plow, 10, 35-37
- Share—
 good condition, 11, 12, 13
 suction requirements, 12-13
- Side draft—
 on horse plows, 25-26, 28
 on tractor plows, 30-31, 33
- Speed of plowing, 6
- Spring or fall plowing, 6-7
- Stalk cutter, 8
- Suction requirements—
 landside, 12, 13
 share, 12, 13
- Tandem hitches, 26-27
- Tractor hitches—
 proper and improper, 30-31, 32, 33
 types of, 34
- Trash coverage—
 need for, 4, 5
 practices that aid, 4-9
 precautions after plowing, 6
 variation in, 5, 6
- Trash guards, 23
- Vertical hitch—
 for horse plows, 25-26, 28
 for tractor plows, 24-25, 30-31, 34
- Weed hooks, 23
- Wheel adjustments—
 for horse plows, 28-29
 for tractor plows, 31, 35
- Wing bearing, 12-13
- Wires for trash coverage, 22-23

GOOD PLOWING IS DEPENDENT ON—

Right field practices before plowing.

Plow bottoms suited to the soil.

Proper hitch with reference to both
plow and power.

Attachments suited to the work.

Correct adjustment of plow and at-
tachments.

Careful operation of plow and tractor.

. . .

Farmers who are interested in doing a
better job of farming will find helpful
suggestions in this circular.